

# BL5026-P

Embedded  
WiFi/BT Module

Product

Version: 1.1

Release date: 6/1/2022

## Features

- 100MHz 32-bit MCU
- 256KB SRAM / 4MB pSRAM
- External 2MB FLASH
- Support AES, MD5 and SHA1
- Support XIP
- Working voltage: DC5.0V
- Support BLE (BT4.2)
- Wi-Fi Features
  - Support 802.11 b/g/n standards
  - Support station and softAP
  - Support SmartConfig and AP configuration
  - Support WEP/WPA2
  - Support multiple cloud services
  - Integrated balun/PA/LNA
  - TCP/IP stack optimized for IoT application
  - PCB antenna
- Peripherals:
  - 1x UART
- Working environmental temperature: 0~85 °C

## Applications

- Smart transportation
- Smart home / appliances
- Instruments
- Health care
- Industrial automation
- Intelligent security
- Smart energy

## Model

Model	Antenna type	Note
BL5026-P	PCB antenna	Default

## Content

1. Overview.....	- 3 -
2. Basic Specifications.....	- 3 -
2.1. Power Consumption .....	- 3 -
2.2. Working Environment .....	- 4 -
3. Radio Specifications.....	- 4 -
3.1. Basic Radio Specification .....	- 4 -
3.2. Radio Performance .....	- 5 -
3.2.1. IEEE802.11b .....	- 5 -
3.2.2. IEEE 802.11g .....	- 6 -
3.2.3 IEEE802.11n .....	- 7 -
4. BL5026-P Hardware Information.....	- 8 -
4.1. PIN Sequence.....	- 8 -
4.2. PIN Definitions.....	- 8 -
4.3 Recommendations.....	- 9 -
4.4. Mechanical Dimensions.....	- 9 -
4.5. Connector Dimensions .....	- 9 -
4.6 Certifications (To be Added).....	- 10 -
4.7. Label .....	- 10 -
4.7. Shielding Case Dimensions .....	- 10 -
4.8. Packaging .....	- 11 -
5. Reference Design.....	- 12 -
5.1. UART Interface Design.....	- 12 -
5.2. Power Supply Requirement.....	- 12 -
Revision History .....	- 13 -
Copyrights.....	- 14 -
Contact Us .....	- 14 -

## 1. Overview

BL5026-P is a cost-effective embedded Wi-Fi module designed by BroadLink, highly integrated with 32-bit MCU speed up to 100MHz, 256KBSRAM, 4MB pSRAM and 2MB external flash, with 5V power supply.

The module integrates radio transceiver, MAC, baseband, all Wi-Fi protocols, configurations and network stack. It can be widely used in applications like smart home devices, remote monitoring devices and medical care instruments.

## 2. Basic Specifications

### 2.1. Power Consumption

Please refer to Table 1 for power consumption data.

Table 1: BL5026-P Power Consumption Data

Specifications	Min.	Typ.	Max.	Units
VDD	4.5	5	5.5	V
VIL(input low voltage)			0.8	V
VIH(input high voltage)	4		VDD	V
VOL(output low voltage)			0.4	V
VOH(output high voltage)	4		VDD	V
Standby (RX)		70		mA
pulse current @TX 11b @17dBm 11Mbps			280	mA
pulse current @TX 11g @15dBm 54Mbps			260	mA
pulse current @TX			255	mA

11n @14.5dBm 65Mbps				
BLE @6dBm			180	mA

## 2.2. Working Environment

Please refer to Table 2 for working environment data.

Table 2: BL3372-P Working Environment Data

Symbol	Description	Min.	Max.	Units
Ts	Storage temperature	-40	125	°C
TA	Ambient operating temperature	0	85	°C
Vdd	Supply voltage	4.5	5.5	V
Vio	Voltage on IO pin	0	5.5	V

## 3. Radio Specifications



### 3.1. Basic Radio Specification

Please refer to Table 3 for radio specification.

Table 3: BL5026-P Radio Specification

Radio range	2.412GHz - 2.462GHz
Wireless standards	IEEE 802.11 b/g/n
Radio output (conductive)	802.11b:15±1.5dBm@11Mbps
	802.11g:14.5±1.5dBm@54Mbps
	802.11n:13.5±1.5dBm@MCS7/HT20
	BLE:5±2.5dBm
Antenna type	Internal: PCB antenna
	External: Not supported
Receiving sensitivity	802.11b ≤ -90dBm@11Mbps
	802.11g ≤ -76dBm@54Mbps
	802.11n/HT20 ≤ -73dBm@MCS7
	BLE ≤ -97dBm
Stack	IPv4, TCP/UDP/FTP/HTTP/HTTPS/TLS/mDNS

Data rate (max)	11M@802.11b, 54M@802.11g, MCS7@802.11n
Security	Encryption standard: Open/WEP-Open/WPA/WPA2
	Encryption algorithm: WEP64/WEP128/TKIP/AES
Network types	STA/AP

## 3.2. Radio Performance

### 3.2.1. IEEE802.11b

Table 4: Basic specifications under IEEE802.11b

ITEM	Specification
Modulation Type	DSSS / CCK
Frequency range	2412 MHz~ 2462 MHz
Channel	CH1 to CH11
Data rate	1, 2, 5.5, 11Mbps

Table 5: Transmitting performance under IEEE802.11b

TX Characteristics	Min.	Typical	Max.	Unit
<b>Power@11Mbps</b>		<b>17</b>		dBm
<b>Frequency Error</b>	<b>-15</b>		<b>+15</b>	ppm
<b>EVM@11Mbps</b>			<b>-14</b>	dB
<b>Transmit spectrum mask</b>				
<b>Pass</b>				

Table 6: Receiving performance under IEEE802.11b

RX Characteristics	Min	Typical	Max.	Unit
<b>11Mbps Input Level Sensitivity</b>				
Minimum Input Level (FER $\leq$ 8%)			<b>-90</b>	dBm

### 3.2.2. IEEE 802.11g

Table 7: Basic specifications under IEEE802.11g

ITEM	Specification
Modulation Type	OFDM
Frequency range	2412 MHz~ 2462 MHz
Channel	CH1 to CH11
Data rate	6, 9, 12, 18, 24, 36, 48, 54Mbps

Table 8: Transmitting performance under IEEE802.11g

TX Characteristics	Min.	Typical	Max.	Unit
<b>Power@54Mbps</b>		<b>15</b>		dBm
<b>Frequency Error</b>	<b>-15</b>		<b>+15</b>	ppm
<b>EVM@54Mbps</b>			-30	dB
<b>Transmit spectrum mask</b>	BroadLink			
Pass				

Table 9: Receiving performance under IEEE802.11g

RX Characteristics	Min	Typical	Max.	Unit
<b>54Mbps Input Level Sensitivity</b>				
Minimum Input Level (FER $\leq$ 10%)			<b>-76</b>	dBm

### 3.2.3 IEEE802.11n

IEEE802.11n 20MHz bandwidth mode

Table 10: Basic specifications under IEEE802.11n with 20MHz

ITEM	Specification
Modulation Type	OFDM
Frequency range	2412 MHz~ 2462 MHz
Channel	CH1 to CH11
Data rate	MCS0/1/2/3/4/5/6/7

Table 11: Transmitting performance under IEEE802.11n with 20MHz

TX Characteristics	Min.	Typical	Max.	Unit
<b>Power@HT20, MCS7</b>		<b>14.5</b>		dBm
<b>Frequency Error</b>	<b>-15</b>		<b>+15</b>	ppm
<b>EVM@HT20, MCS7</b>			<b>-30</b>	dB
<b>Transmit spectrum mask</b>				
<b>Pass</b>				

Table 12: Receiving performance under IEEE802.11n with 20MHz

RX Characteristics	Min	Typical	Max.	Unit
<b>MCS7 Input Level Sensitivity</b>				
Minimum Input Level (FER $\leq$ 10%)			<b>-73</b>	dBm

## 4. BL5026-P Hardware Information

### 4.1. PIN Sequence

Please refer to Fig 1 for the pin sequence.

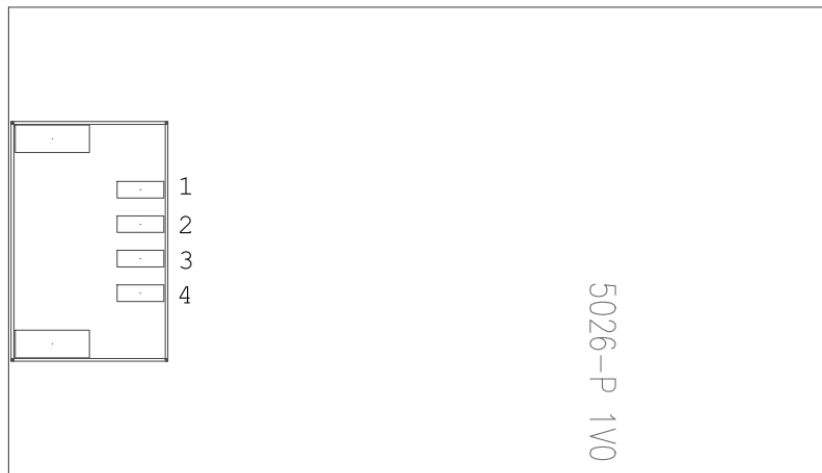

Fig 1:BL5026-P pin sequence(TOP VIEW)

### 4.2. PIN Definitions

Please refer to Table 13 for pin definitions.

Pin	Definitions	Note
Pin1	UART_TX_5V	UART passthrough; Module TX; 5V level
Pin2	UART_RX_5V	UART passthrough; Module RX; 5V level
Pin3	VCC	5V
Pin4	GND	GND

Table 13: BL5026-P pin definitions

Note:

1. UART\_TX\_5V, UART\_RX\_5V is used for communication with external MCU powered by 5V. Please refer to the description in 1.1. 3. DC Characteristics for UART output current level.



### 4.3 Recommendations

The following precautions should be considered during PCB designing:

It is recommended to not place any electrical components within 10mm range of module antenna and not design any circuit or bond copper on main board under this area.

Do not use the module inside any metal case or containers with metal painting.

### 4.4. Mechanical Dimensions

Please refer to Fig 3 for the dimensions of module.

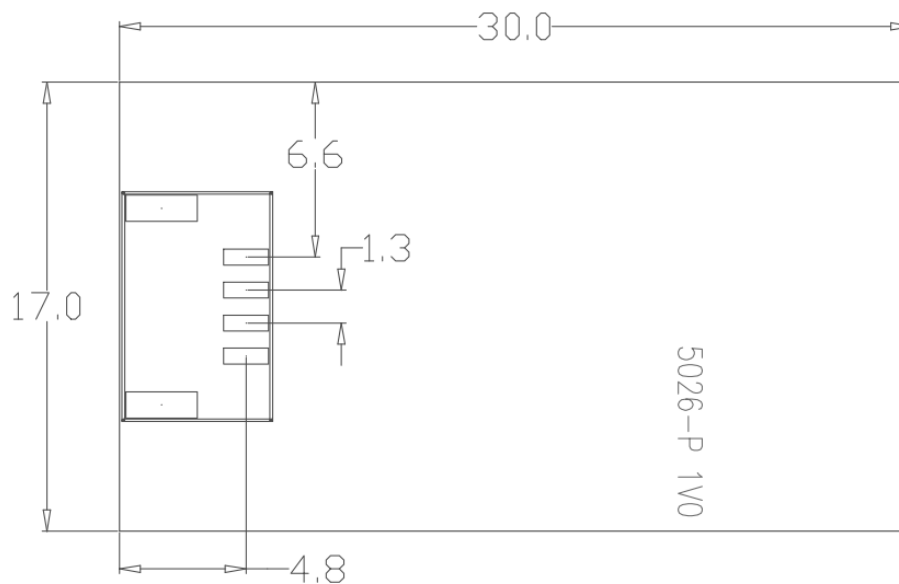
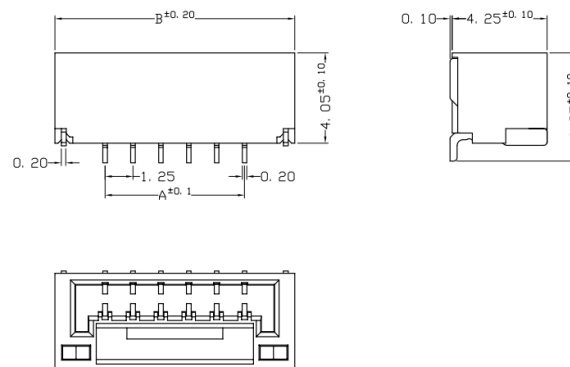

Fig 3: BL5026-P Dimensions

Note: Dimensions (17±0.2) mm \* (30±0.2) mm \* (7.5± 10%)mm (with shielding case)

### 4.5. Connector Dimensions

Please refer to Fig 4 for the dimensions of connector



#### 4.6 Certifications (To be Added)

#### 4.7. Label

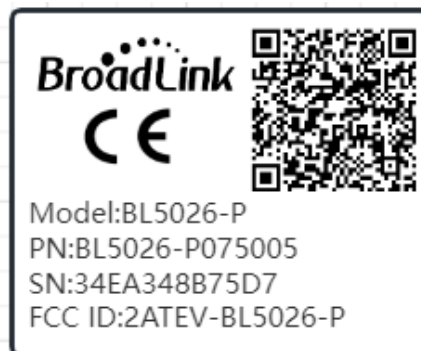

Fig 5: BL5026-P label content

Please refer to Fig 8 for the content description on label.

Model: BL5026-P: Module model

SN: 00ACA3FE75D7: Module unique MAC address

Ver: \*\*\*\*\*: Firmware version

#### 4.7. Shielding Case Dimensions

Please refer to Fig 6 for the dimensions of shielding case.

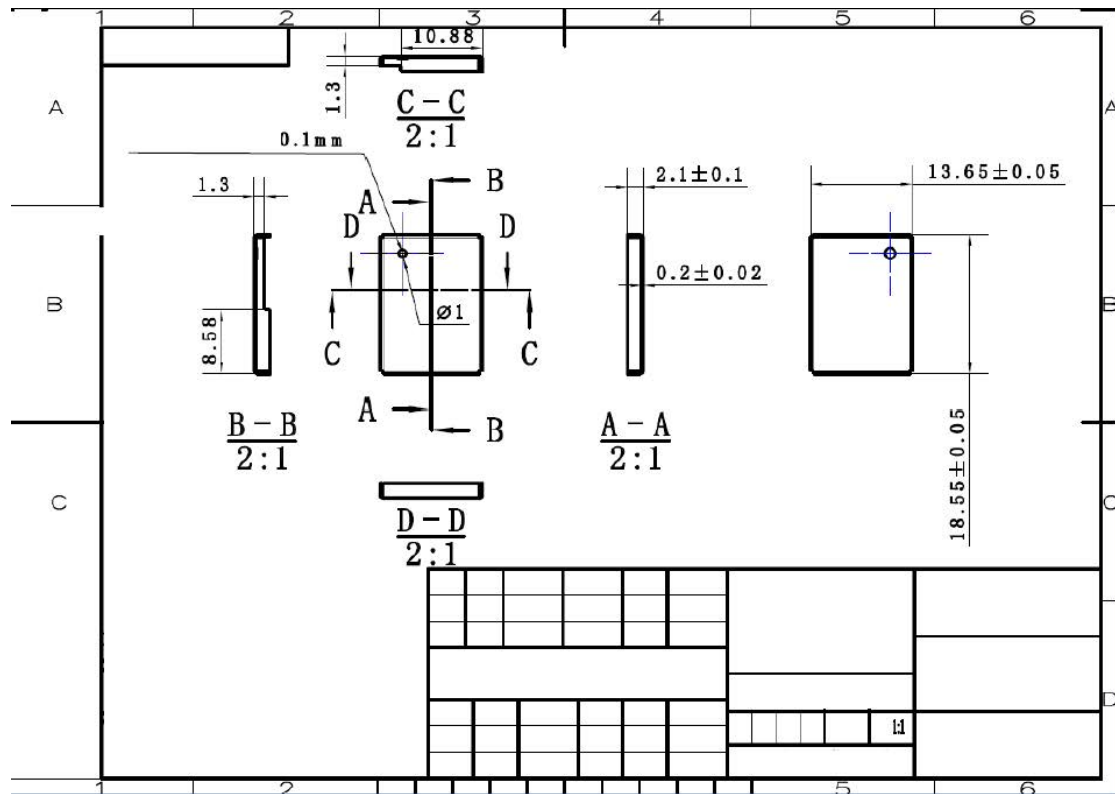

Fig 6: BL5026-P Dimensions of shielding case

BroadLink

(Unit: mm)

#### 4.8. Packaging

ESD bag + honeycomb carton

## 5. Reference Design

### 5.1. UART Interface Design

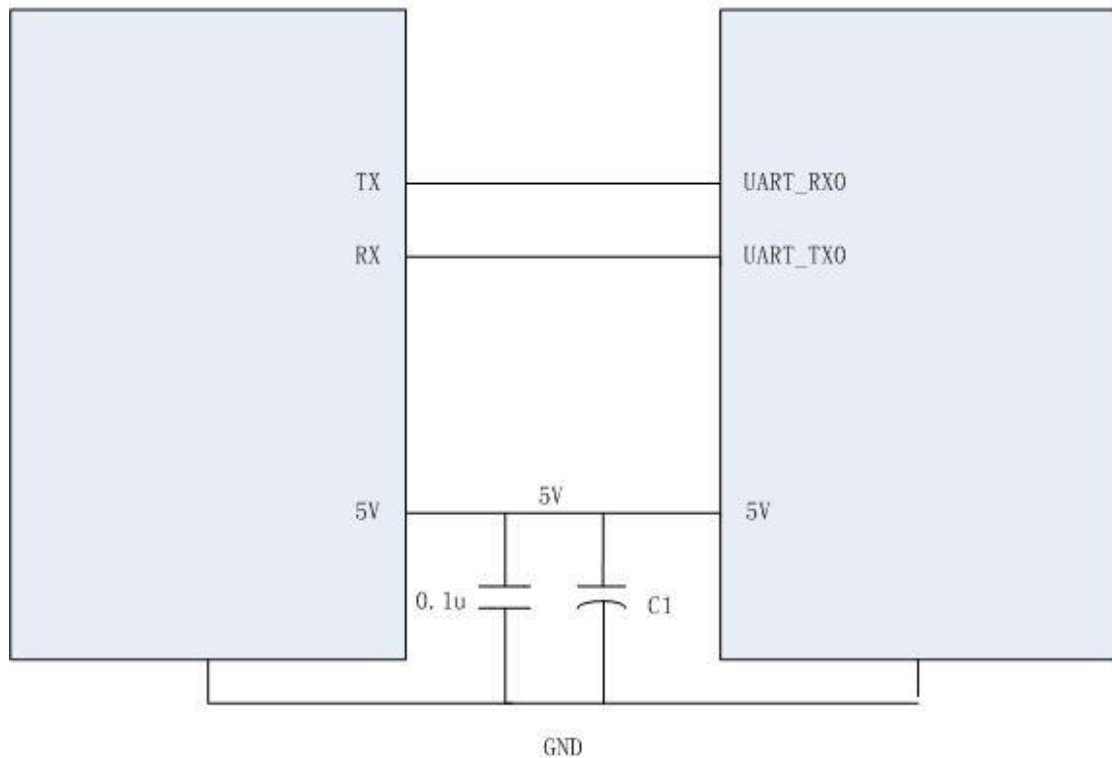

For devices with 5V power supply, you can directly connect the device UART port with module UART port according to the illustration.

### 5.2. Power Supply Requirement

It is recommended to supply the module with power higher than 400mA to ensure enough power supply to the module and avoid power down during data.

You can change the spec of capacitor at C1 according to actual hardware design to fit the needs for ripple control (recommended to apply capacitance higher than 22μF).

Caution:

For the following equipment:

Product Name: WiFi/BT Module

Brand Name: ---

Model No.: BL5026-P

Hangzhou BroadLink Technology Co., Ltd.

E-mail: mengjiao.yan@broadlink.com.cn

hereby declares that this [Name: WiFi/BT Module, Model: BL5026-P] is in compliance with the essential requirements and other relevant provisions of Directive 2014/53/EU.



This product is intended for sale and application in a business environment.

RED Article 10 2

-This product can be used across EU member states

RED Article 10 10

-The product is class 1 product, No restrictions

The RF distance between body and product is 20cm

Wi-Fi

Support Standards: 802.11b, 802.11g, 802.11n-HT20

Frequency Range: 2412-2462MHz for 802.11b/g/n(HT20)

Max.RF Output Power: 16.34dBm (EIRP)

Bluetooth

Bluetooth Version: Bluetooth V4.2(only BLE)

Frequency Range: 2402-2480MHz

Max.RF Output Power: 7.28dBm (EIRP)

## Revision History

Date	Version	Updated Content
3/2/2022	1.0	Preliminary version
6/1/2022	1.1	Added part of electrical parameters

## Copyrights

It is prohibited to use or copy all or any part of contents in this manual without prior permission, especially applicable for trademarks, models, part numbers and figures.

## Contact Us



Hangzhou BroadLink Technology Co., Ltd.

Add: Building C, 57 Jiang' er Road, Binjiang District, Hangzhou, P.R.China

Postcode: 310052

Tel: +86-571-85071744-8010

Email: [bingqi.zhou@broadlink.com.cn](mailto:bingqi.zhou@broadlink.com.cn)

-----  
For more information of BroadLink Wi-Fi modules, please visit our website:

[www.broadlink.com.cn](http://www.broadlink.com.cn)

List of applicable FCC rules  
FCC Part 15.247

Label and compliance information

FCC ID label on the final system must be labeled with “Contains FCC ID: 2ATEV-BL5026-P” or “Contains transmitter module FCC ID: 2ATEV-BL5026-P”.

Information on test modes and additional testing requirements

Contact Hangzhou BroadLink Technology Co., Ltd. will provide stand-alone modular transmitter test mode. Additional testing and certification may be necessary when multiple modules are used in a host.

Additional testing, Part 15 Subpart B disclaimer

To ensure compliance with all non-transmitter functions the host manufacturer is responsible for ensuring compliance with the module(s) installed and fully operational. For example, if a host was previously authorized as an unintentional radiator under the Supplier’s Declaration of Conformity procedure without a transmitter certified module and a module is added, the host manufacturer is responsible for ensuring that after the module is installed and operational the host continues to be compliant with the Part 15B unintentional radiator requirements. Since this may depend on the details of how the module is integrated with the host, Hangzhou BroadLink Technology Co., Ltd. shall provide guidance to the host manufacturer for compliance with the Part 15B requirements.

FCC Warning

This device complies with Part 15 of the FCC Rules. Operation is subject to the following two conditions:

(1) This device may not cause harmful interference, and (2) this device must accept any interference received, including interference that may cause undesired operation.

NOTE 1: Any changes or modifications to this unit not expressly approved by the party responsible for compliance could void the user's authority to operate the equipment.

FCC Radiation Exposure Statement:

This equipment complies with FCC radiation exposure limits set forth for an uncontrolled environment. End users must follow the specific operating instructions for satisfying RF exposure compliance.

Note 1: This module certified that complies with RF exposure requirement under mobile or fixed condition, this module is to be installed only in mobile or fixed applications.

A mobile device is defined as a transmitting device designed to be used in other than fixed locations and to generally be used in such a way that a separation distance of at least 20 centimeters is normally maintained between the transmitter's radiating structure(s) and the body of the user or nearby persons. Transmitting devices designed to be used by consumers or workers that can be easily re-located, such as wireless devices associated with a personal computer, are considered to be mobile devices if they meet the 20 centimeter separation requirement.

A fixed device is defined as a device is physically secured at one location and is not able to be easily moved to another location.

Note 2: Any modifications made to the module will void the Grant of Certification, this module is limited to OEM installation only and must not be sold to end-users, end-user has no manual instructions to remove or install the device, only software or operating procedure shall be placed in the end-user operating manual of final products.

Note 3: The module may be operated only with the antenna with which it is authorized. Any antenna that is of the same type and of equal or less directional gain as an antenna that is authorized with the intentional radiator may be marketed with, and used with, that intentional radiator.

Note 4: For all products market in US, OEM has to limit the operation channels in CH1 to CH11 for 2.4G band by supplied firmware programming tool. OEM shall not supply any tool or info to the end-user regarding to Regulatory Domain change.

#### IC WARNING

This device contains licence-exempt transmitter(s) that comply with Innovation, Science and Economic Development Canada's licence-exempt RSS(s). Operation is subject to the following two conditions:

(1) This device may not cause interference.

(2) This device must accept any interference, including interference that may cause undesired operation of the device.

L'émetteur/récepteur exempt de licence contenu dans le présent appareil est conforme aux CNR d'Innovation, Sciences et Développement économique Canada applicables aux appareils radio exempts de licence. L'exploitation est autorisée aux deux conditions suivantes:

1. L'appareil ne doit pas produire de brouillage;
2. L'appareil doit accepter tout brouillage radioélectrique subi, même si le brouillage est susceptible d'en compromettre le fonctionnement.

#### IC Radiation Exposure Statement:

This device and its antenna(s) must not be co-located with any other transmitters except in accordance with IC multi-transmitter product procedures. Referring to the multi-transmitter policy, multiple-transmitter(s) and module(s) can be operated simultaneously without reassessment permissive change.

Cet appareil et son antenne (s) ne doit pas être co-localisés ou fonctionnement en association avec une autre antenne ou transmetteur.

This equipment complies with IC RSS-102 radiation exposure limits set forth for an uncontrolled environment. This equipment should be installed and operated with minimum distance 20cm between the radiator & your body.

Cet équipement est conforme aux limites d'exposition aux rayonnements IC établies pour un environnement non contrôlé. Cet équipement doit être installé et utilisé avec un minimum de 20cm de distance entre la source de rayonnement et votre corps.

This module is limited to OEM installation only and must not be sold to end-users, end-user has no manual instructions to remove or install the device, only software or operating procedure shall be placed in the end-user operating manual of final products. Additional testing and certification may be necessary when multiple modules are used.

Any changes or modifications not expressly approved by the manufacturer could void the user's authority to operate this equipment.

The final end product must be labeled in a visible area with the following " Contains IC: 25062-BL5026P ".