

# BL3385-P

Embedded

Product

Version: 1.0

Release date: June, 16, 20,21

## Features

- Support IEEE802.11 b/g/n standards
- Support WEP, WPA and WPA2 encryption
- Support UART/PWM/ADC/GPIO/I2C

interfaces

- Support STA/AP/AP+STA modes
- Support SmartConfig
- Support TLS/SSL protocols
- Support PCB antenna
- 3.3V power supply
- Wi-Fi related features
  - Support 802.11 b/g/n with 20M
  - Support station and soft AP
  - Support Smart Config and AP

configuration

- Integrated balun/PA/LNA
- TCP/IP stack optimized for IoT

application

- PCB antenna
- Peripheral
  - 2x UART
  - 1x I2C
  - 1x SPI

- 4x PWM
- Up to 14GPIOs

- Working temperature: -10°C to +85°C
- Stamp style SMD for surface mounting production

## Applications

- Smart transportation
- Smart home / appliances
- Instruments
- Health care
- Industrial automation
- Intelligent security
- Smart energy

## Models

Model	Antenna type	Note
BL3385-P	PCB antenna	Default

Content

1. Overview.....	- 3 -
2. Basic Specifications.....	- 3 -
2.1. Power Consumption .....	- 3 -
2.2. Working Environment .....	- 4 -
3. Radio Specifications.....	- 4 -
3.1. Basic Radio Specification .....	- 4 -
3.2. Radio Performance .....	- 5 -
3.2.1. IEEE 802.11b .....	- 5 -
3.2.2. IEEE 802.11g .....	- 5 -
3.2.3 IEEE802.11n.....	- 6 -
4. BL3385-P Hardware Information.....	- 7 -
4.1. Footprint Sequence .....	- 7 -
4.2. Footprint Definitions .....	- 8 -
4.3. PCB Antenna.....	- 9 -
5. Reference Design.....	- 10 -
5.1. UART Interface Design.....	- 10 -
5.2. Power Supply Requirement.....	- 12 -
Revision History .....	- 13 -
Copyrights.....	- 13 -
Contact Us .....	- 13 -

## 1. Overview

BL3385-P is a cost-effective embedded Wi-Fi module designed by BroadLink, which supports 802.11 b/g/n standards and UART communication with other devices. The module integrates radio transceiver, MAC, baseband, all Wi-Fi protocols, configurations and network stack. It can be widely used in applications like smart home devices, remote monitoring devices and medical care instruments.

The module integrates an ARM Cortex-M4 processor speed up to 160MHz with 352KB SRAM and 1MB flash.

## 2. Basic Specifications

### 2.1. Power Consumption

Please refer to Table 1 for power consumption data.

Table 1 BL3385-P Power Consumption Data

Specifications	Min.	Typ.	Max.	Units
VDD <sup>1</sup>	<b>3.3</b>	<b>3.3</b>	<b>3.6</b>	V
VIL(input low voltage)	0		0.8	V
VIH(input high voltage)	2.0		3.6	V
VOL(output low voltage)			0.4	V
VOH(output high voltage)	2.4		3.6	V
Io			10	mA
Standby (SP mini)		80	85	mA
pulse current @TX 11b @13.83dBm 11Mbps			305	mA
pulse current @TX 11g @12.45dBm 54Mbps			250	mA
pulse current @TX 11n @12.65dBm 65Mbps			225	mA
Networking			305	mA

**Note: Make sure VDD is not lower than 3.3V**

## 2.2. Working Environment

Please refer to Table 2 for working environment data.

Table 2 BL3385-P Working Environment Data

Symbol	Description	Min.	Max.	Units
Ts	Storage temperature	-40	125	°C
TA	Ambient operating temperature	-10	85	°C
Vdd	Supply voltage	<b>3.3</b>	<b>4</b>	V
Vio	Voltage on IO pin	0	VDD	V
ESD	HBM	1000	2000	V

## 3. Radio Specifications

### 3.1. Basic Radio Specification

Please refer to Table 3 for radio specification.

Table 3 BL3385-P Radio Specification

Radio range	2.412 GHz - 2.462 GHz
Wireless standards	IEEE 802.11 b/g/n
Radio output	802.11b:13.83dBm 802.11g:12.45dBm 802.11n:12.65dBm BLE:4.81dBm
Antenna type	Internal: PCB antenna External: Not supported
Receiving sensitivity	802.11b<-89dBm@11Mbps 802.11g<-76dBm@54Mbps 802.11n<-73dBm@MCS7
Stack	IPv4, TCP/UDP/FTP/HTTP/HTTPS/TLS/mDNS
Data rate (max)	11M@802.11b, 54M@802.11g, MCS7@802.11n
Security	Encryption standard: Open/WEP-Open/WPA/WPA2 Encryption algorithm: WEP64/WEP128/TKIP/AES
Network types	STA/AP/STA+AP/WIFI Direct

## 3.2. Radio Performance

### 3.2.1. IEEE 802.11b

Table 4 Basic specifications under IEEE802.11b

ITEM	Specification
Modulation Type	DSSS
Frequency range	2412MHz~2462MHz
Channel	CH1 to CH11
Data rate	1, 2, 5.5, 11Mbps

Table 5 Transmitting performance under IEEE802.11b

TX Characteristics	Min.	Typical	Max.	Unit
<b>Power@11Mbps</b>	<b>13.09</b>		<b>13.83</b>	dBm
<b>Frequency Error</b>	<b>-10</b>		<b>+10</b>	ppm
<b>EVM@11Mbps</b>			<b>-15</b>	dB
<b>Transmit spectrum mask</b>				
<b>Pass</b>				

Table 6 Receiving performance under IEEE802.11b

RX Characteristics	Min	Typical	Max.	Unit
<b>Minimum Input Level Sensitivity</b>				
11Mbps (FER $\leq$ 8%)		<b>-90</b>		dBm

### 3.2.2. IEEE 802.11g

Table 7 Basic specifications under IEEE802.11g

ITEM	Specification
Modulation Type	OFDM
Frequency range	2412MHz~2462MHz
Channel	CH1 to CH11

Data rate	6, 9, 12, 18, 24, 36, 48, 54Mbps
-----------	----------------------------------

Table 8 Transmitting performance under IEEE802.11g

TX Characteristics	Min.	Typical	Max.	Unit
<b>Power@54Mbps</b>	<b>11.62</b>		<b>12.45</b>	dBm
<b>Frequency Error</b>	<b>-10</b>		<b>+10</b>	ppm
<b>EVM@54Mbps</b>		-30	-29	dB
<b>Transmit spectrum mask</b>				
Pass				

Table 9 Receiving performance under IEEE802.11g

RX Characteristics	Min.	Typical	Max.	Unit
<b>Minimum Input Level Sensitivity</b>				
54Mbps		-77		dBm

### 3.2.3 IEEE802.11n

IEEE802.11n 20MHz bandwidth mode

Table 10 Basic specifications under IEEE802.11n with 20MHz

ITEM	Specification
Modulation Type	OFDM
Frequency range	2412MHz~2462MHz
Channel	CH1 to CH11
Data rate	MCS0/1/2/3/4/5/6/7

Table 11 Transmitting performance under IEEE802.11n with 20MHz

TX Characteristics	Min.	Typical	Max.	Unit
<b>Power@HT20, MCS7</b>	<b>11.82</b>		<b>12.65</b>	dBm

Frequency Error	-10		+10	ppm
EVM@HT20, MCS7			-29	dB
Transmit spectrum mask				
Pass				

Table 12 Receiving performance under IEEE802.11n with 20MHz

RX Characteristics	Min.	Typical	Max.	Unit
<b>Minimum Input Level Sensitivity</b>				
MCS7		-72		dBm

## 4. BL3385-P Hardware Information

### 4.1. Footprint Sequence

Please refer to Fig 1 for the footprint sequence of BL3385-P.

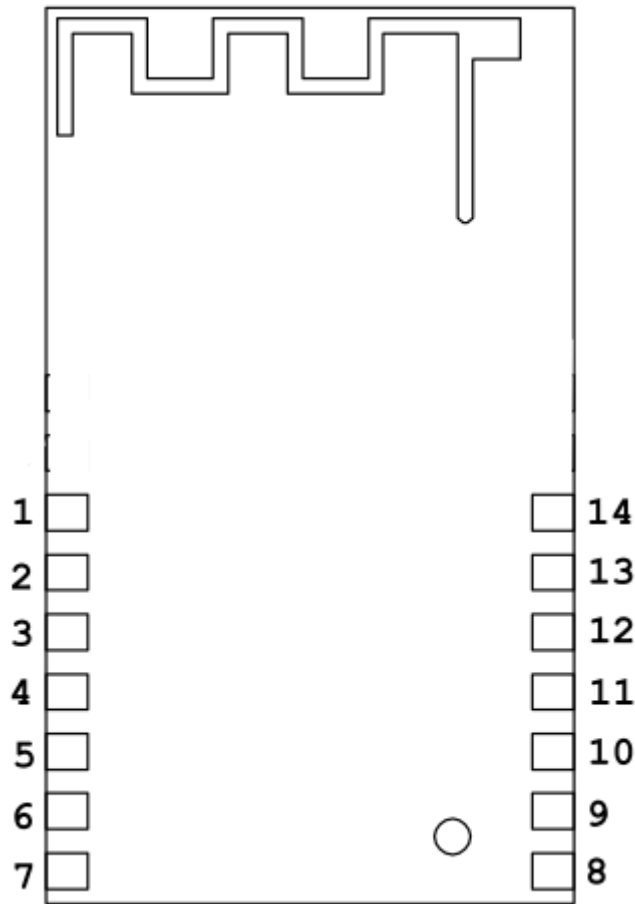

Fig 1 BL3385-P Footprint sequence

## 4.2. Footprint Definitions

Please refer to Table 16 for the footprint definitions of BL3385-P.

Table 13 BL3385-P footprint definitions

PIN	Function1	Function2	Function3	Function4	Function5
1	GDN				
2	VDD				
3	RST				
4	GPIO14	TX0			
5	GPIO13	RX0			
6	GPIO16	TX2			SI-SCL
7	GPIO15	RX2			SPI-CS
8	GPIO0		PWM0		
9	GPIO17		PWM5		
10	GPIO18		PWM6		



11	GPIO19		PWM7		SPI-MOSI
12	GPIO20		PWM0		SPI-MISO
13	VDD				
14	GND				

**Note:**

1. In default, UART2 (pin4 and pin5) are used for bypass communication and UART0 (pin6 and pin7) are used for output of debugging information and burning firmware. Please refer to the description in DC Characteristics for UART output current level.

2. GPIO0 is the hardware function pin, avoid pulling up the two pins before powering on

3. GPIO0 and GPIO13 are pulled up at the same time. After the module is powered on, it enters the burning mode

### 4.3. PCB Antenna

Please refer to Fig 2 for PCB antenna. Please avoid to place any electrical components, wiring or grounding under PCB antenna area on main board and it's better to leave this area blank on PCB.

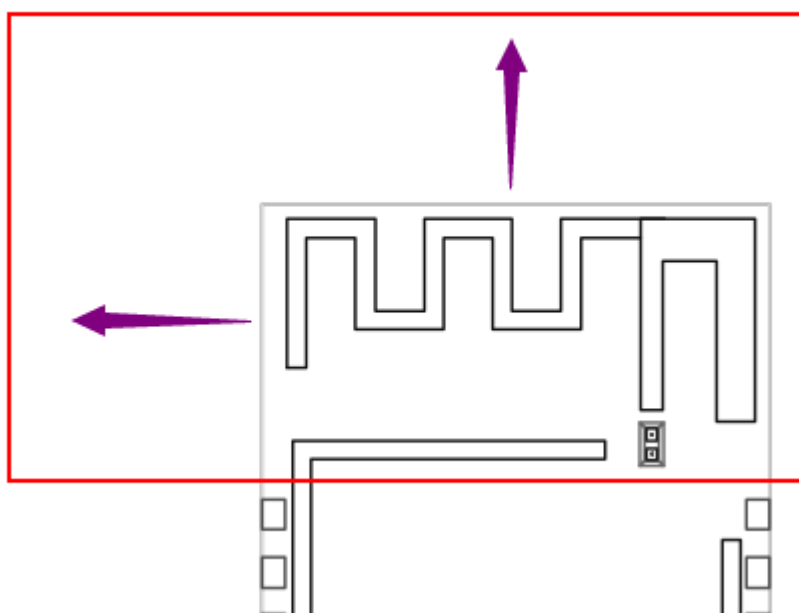

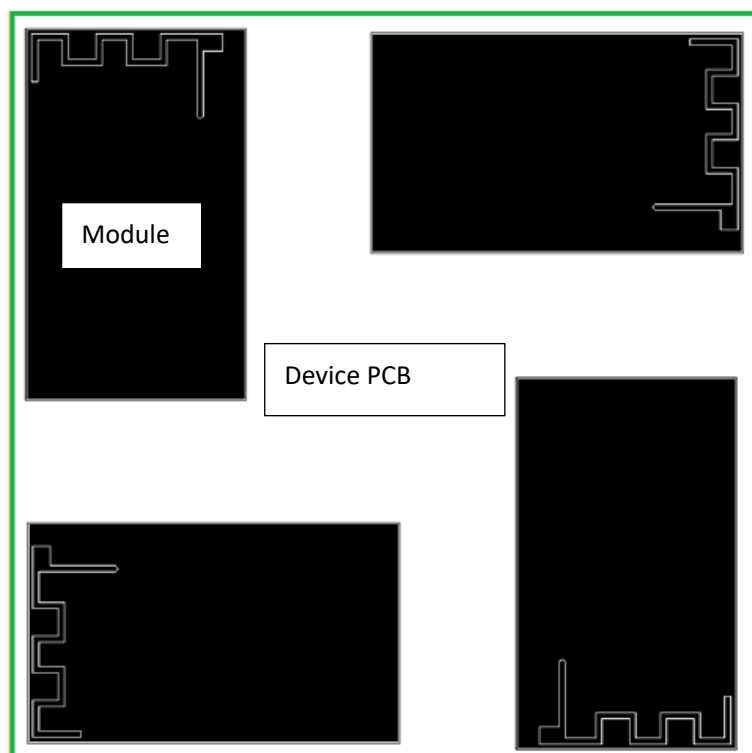

Fig 2 BL3385-P Recommended PCB layout

## 5. Reference Design

### 5.1. UART Interface Design

For devices with 3.3V power supply, you can directly connect the device UART port with module UART port according to the illustration in Fig Fig 7.

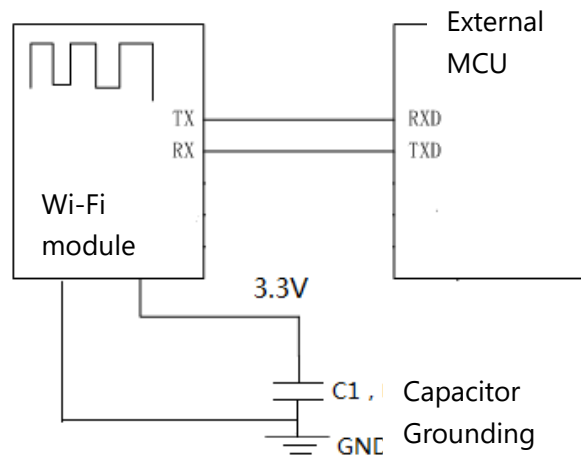

Fig 3 Circuit diagram (3.3V)

If your device is powered by 5V, you can refer to the circuit shown in Fig Fig 8 or design your own circuit for power conversion. The value of resistor can be adjusted according to actual circuit design.

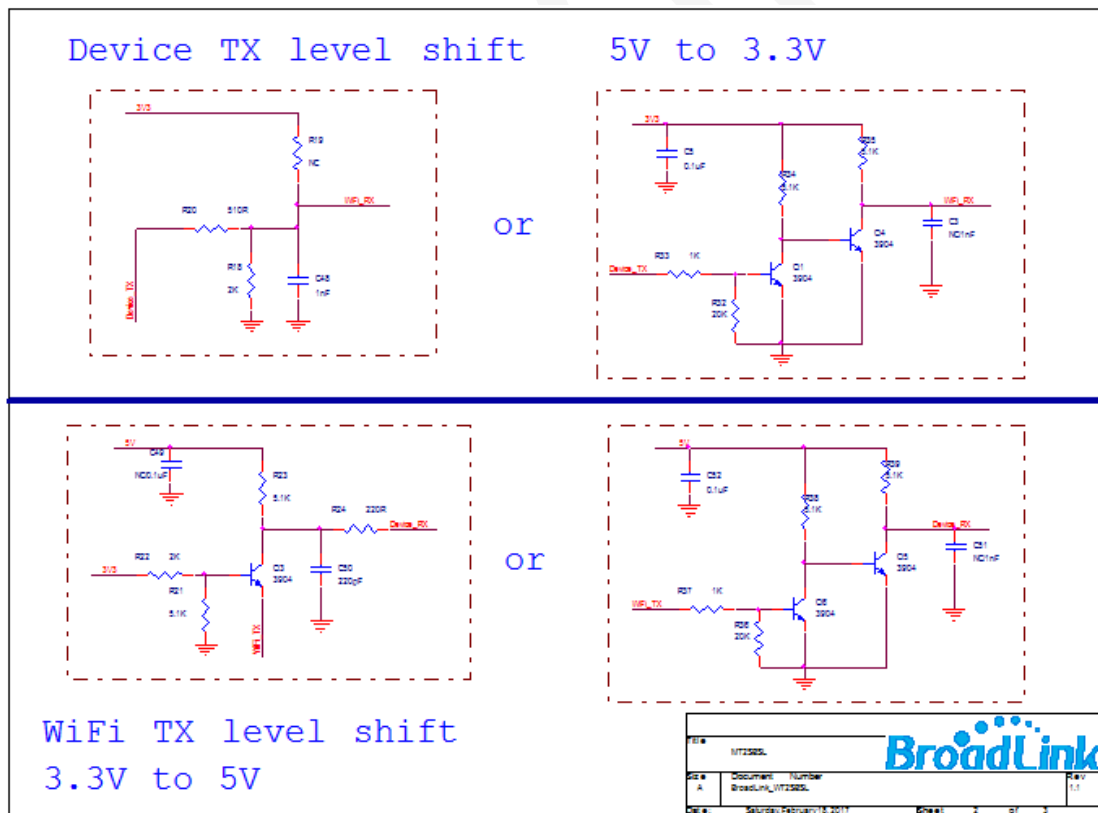

Fig 4 Circuit diagram (5V)

## 5.2. Power Supply Requirement

If an LDO is used to supply the module with 3.3V power, C1 capacitor can be considered to be used with 10u-22u; If a DCDC is used to supply 3.3V power, C1 capacitor can be considered to be used with 22uF.

It is recommended to supply the module with power higher than 400mA to ensure enough power supply to the module and avoid power down during data transmission.

## Revision History

Date	Version	Updated Content
June 16, 2021	1.0	Preliminary version

## Copyrights

It is prohibited to use or copy all or any part of contents in this manual without prior permission, especially applicable for trademarks, models, part numbers and figures.

## Contact Us



Ms Zhou

Hangzhou Gubei Electronics Technology Co., Ltd.

Add: Room 106, Building 1, No. 611 Jianghong Road, Binjiang District, Hangzhou,

P.R.China Postcode: 310052

Tel: 0571-85071744-8010

Email: [bingqi.zhou@broadlink.com.cn](mailto:bingqi.zhou@broadlink.com.cn)

For more information of BroadLink Wi-Fi modules, please visit our website:

[www.broadlink.com.cn](http://www.broadlink.com.cn)

FCC ID:2ATEV-BL3385-P  
IC ID:25062-BL3385P  
CAN ICES-3 (B)/NMB-3(B)

Please take attention that changes or modification not expressly approved by the party responsible for compliance could void the user's authority to operate the equipment.

This device complies with Part 15 of the FCC Rules. Operation is subject to the following two conditions:

- (1) This device may not cause harmful interference, and
- (2) This device must accept any interference received, including interference that may cause undesired operation.

This equipment complies with FCC/IC RSS-102 radiation exposure limits set forth for an uncontrolled environment. This equipment should be installed and operated with minimum distance 20cm between the radiator & your body.

This device complies with Industry Canada licence-exempt RSS standard(s).

Operation is subject to the following two conditions:

- (1) this device may not cause interference, and
- (2) this device must accept any interference, including interference that may cause undesired operation of the device.

Le présent appareil est conforme aux CNR d'Industrie Canada applicables aux appareils radioexempts de licence. L'exploitation est autorisée aux deux conditions suivantes :

- (1) l'appareil ne doit pas produire de brouillage, et
- (2) l'utilisateur de l'appareil doit accepter tout brouillage radioélectrique subi, même si le brouillage est susceptible d'en compromettre le fonctionnement.

This equipment complies with FCC/IC RSS-102 radiation exposure limits set forth for an uncontrolled environment. This equipment should be installed and operated with minimum distance 20cm between the radiator & your body.

ce matériel est conforme aux limites de dose d'exposition aux rayonnements, FCC / CNR-102 énoncée dans un autre environnement. cette equipment devrait être installé et exploité avec distance minimale de 20 entre le radiateur et votre corps.

**(1) Operational use conditions**

\*\*\*if your module has professional users use condition limitations, please keep below sentence here Module has professional users use condition limitations, Host product manufacturer please ensure giving such warning like “Product is limited to professional users use” in your product’s instruction.

**(2) Antenna used**

Antenna Type	Brand/ manufacturer	Model No.	Max. Antenna Gain
PCB	Hangzhou BroadLink Technology Co.,Ltd	/	2dBi

**(3) Notice to Host Product Manufacturer**

Any deviation(s) from the defined parameters of the antenna trace, as described by this instruction, host product manufacturer must notify us that you wish to change the antenna trace design. In this case, a Class II permissive change application is required to be filed by us, or you (host manufacturer) can take responsibility through the change in FCC ID and IC ID (new application) procedure followed by a Class II permissive change application.

**(4) Labelling Instruction for Host Product Integrator**

Please notice that if the FCC and IC identification number is not visible when the module is installed inside another device, then the outside of the device into which the module is installed must also display a label referring to the enclosed module. This exterior label can use wording such as the following:

“Contains FCC ID: 2ATEV-BL3385-P” and “Contains IC: 25062-BL3385P” any similar wording that expresses the same meaning may be used.

§ 15.19 and RSS-Gen Labelling requirements shall be complied on end user device. Labelling rules for special device, please refer to §2.925, § 15.19 (a)(5) and relevant KDB publications. For E-label, please refer to §2.935.

**(5) Installation Notice to Host Product Manufacturer**

The OEM integrator is responsible for ensuring that the end-user has no manual instruction to remove or install module.

The module is limited to installation in mobile application, a separate approval is required for all other operating configurations, including portable configurations with respect to §2.1093 and difference antenna configurations.

**(6) Antenna Change Notice to Host manufacturer**

If you desire to increase antenna gain and either change antenna type or use same antenna type certified, a Class II permissive change application is required to be filed by us, or you (host manufacturer) can take responsibility through the change in FCC ID and IC ID (new application) procedure followed by a Class II permissive change application.

**(7) FCC other Parts, Part 15B Compliance Requirements for Host product manufacturer**

This modular transmitter is only FCC authorized for the specific rule parts listed on our grant, host product manufacturer is responsible for compliance to any

other FCC rules that apply to the host not covered by the modular transmitter grant of certification.

Host manufacturer in any case shall ensure host product which is installed and operating with the module is in compliant with Part 15B requirements.

Please note that For a Class B or Class A digital device or peripheral, the instructions furnished the user manual of the end-user product shall include statement set out in §15.105 Information to the user or such similar statement and place it in a prominent location in the text of host product manual. Original texts as following:

#### **For Class B**

*Note: This equipment has been tested and found to comply with the limits for a Class B digital device, pursuant to part 15 of the FCC Rules. These limits are designed to provide reasonable protection against harmful interference in a residential installation. This equipment generates, uses and can radiate radio frequency energy and, if not installed and used in accordance with the instructions, may cause harmful interference to radio communications. However, there is no guarantee that interference will not occur in a particular installation. If this equipment does cause harmful interference to radio or television reception, which can be determined by turning the equipment off and on, the user is encouraged to try to correct the interference by one or more of the following measures:*

- Reorient or relocate the receiving antenna.*
- Increase the separation between the equipment and receiver.*
- Connect the equipment into an outlet on a circuit different from that to which the receiver is connected.*
- Consult the dealer or an experienced radio/TV technician for help.*

#### **For Class A**

*Note: This equipment has been tested and found to comply with the limits for a Class A digital device, pursuant to part 15 of the FCC Rules. These limits are designed to provide reasonable protection against harmful interference when the equipment is operated in a commercial environment. This equipment generates, uses, and can radiate radio frequency energy and, if not installed and used in accordance with the instruction manual, may cause harmful interference to radio communications. Operation of this equipment in a residential area is likely to cause harmful interference in which case the user will be required to correct the interference at his own expense.*