

BL3372-P

WiFi Module

Product

Version: 1.3

Release date: 30/6/2022

Features

100MHz 32bits MCU
256KB SRAM/4MB pSRAM
External 2MB/4MB FLASH
Support AES, MD5, SHA1
Support XIP
Working voltage: DC 3.3V
Support BLE (BT4.2)
Wi-Fi related features
 Support 802.11 b/g/n standard
 Support station and soft AP
 Support SmartConfig and AP configuration
 Support WEP/WPA2
 Support multiple cloud services
 Integrated balun/PA/LNA
TCP/IP stack optimized for IoT application
 PCB antenna
Peripherals:
 3x UART
 1x SPI
 8x PWM
 Up to 13GPIOs
Working temperature: 0°C to +85°C
Stamp style SMD for surface mounting production

Applications

Smart transportation
Smart home / appliances
Instruments
Health care
Industrial automation
Intelligent security
Smart energy

Model

Model	Antenna type	Note
BL3372-P	PCB antenna	Default

Content

1. Overview.....	- 3 -
2. Basic Specifications	- 3 -
2.1. Power Consumption	- 3 -
2.2. Working Environment	- 4 -
3. Radio Specifications.....	- 4 -
3.1. Basic Radio Specification	- 4 -
3.2. Radio Performance.....	- 5 -
3.2.1 IEEE802.11b.....	- 5 -
3.2.2. IEEE 802.11g.....	- 6 -
3.2.3 IEEE802.11n.....	- 7 -
4. BL3372-P Hardware Information	- 8 -
4.1. PIN Sequence	- 8 -
4.2. PIN Definitions.....	- 8 -
4.3 Recommendations.....	- 9 -
4.4. Mechanical Dimensions.....	- 10 -
4.5. Recommended Pad Size.....	- 11 -
4.6. Certifications.....	- 11 -
4.7. Label.....	- 12 -
4.7. Shielding Case Dimensions	- 12 -
4.8. Packaging.....	- 13 -
5. Reference Design	- 14 -
5.1. UART Interface Design.....	- 14 -
5.2. Power Supply Requirement	- 16 -
Revision History.....	- 17 -
Copyrights	- 17 -
Contact Us.....	- 17 -

1. Overview

BL3372-P is a cost-effective embedded Wi-Fi module designed by BroadLink, highly integrated with 32-bit MCU speed up to 100MHz, 256KB SRAM, 4MB pSRAM and 2MB or 4MB flash, with 3.3V power supply.

The module integrates radio transceiver, MAC, baseband, all Wi-Fi protocols, configurations, and network stack. It can be widely used in applications like smart home devices, remote monitoring devices and medical care instruments.

2. Basic Specifications

2.1. Power Consumption

Please refer to Table 1 for power consumption data.

Table 1 BL3372-P Power Consumption Data

Specifications	Min.	Typ.	Max.	Units
VDD	3.0	3.3	3.6	V
VIL(input low voltage)			0.8	V
VIH(input high voltage)	2.0		3.6	V
VOL(output low voltage)			0.4	V
VOH(output high voltage)	2.4		3.6	V
Standby (RX)		60	70	mA
pulse current @TX 11b @17.5dBm 11Mbps			270	mA
pulse current @TX 11g @16.5dBm 54Mbps			255	mA
pulse current @TX			250	mA

11n @16dBm 65Mbps				
BLE @5.5dBm			160	mA

2.2. Working Environment

Please refer to Table 2 for working environment data.

Table 2 BL3372-P Working Environment Data

Symbol	Description	Min.	Max.	Units
Ts	Storage temperature	-40	125	°C
TA	Ambient operating temperature	0	85	°C
Vdd	Supply voltage	3.0	3.6	V
Vio	Voltage on IO pin	0	3.6	V

BroadLink

3. Radio Specifications

3.1. Basic Radio Specification

Please refer to Table 3 for radio specification.

Table 3 BL3372-P Radio Specification

Radio range	2.412 GHz - 2.462 GHz
Wireless standards	IEEE 802.11 b/g/n
Radio output (conductive)	802.11b: 17.5±1.5dBm@11Mbps
	802.11g: 14.5±1.5dBm@54Mbps
	802.11n: 13.0±1.5dBm@MCS7/HT20
	BLE: 6±2dBm
Antenna type	Internal: PCB antenna
	External: Not supported
Receiving sensitivity	802.11b ≤ -90dBm@11Mbps

	802.11g \leq -76dBm@54Mbps
	802.11n/HT20 \leq -73dBm@MCS7
	BLE \leq - 98dBm
Stack	IPv4, TCP/UDP/FTP/HTTP/HTTPS/TLS/mDNS
Data rate (max)	11M@802.11b, 54M@802.11g, MCS7@802.11n
Security	Encryption standard: Open/WEP-Open/WPA/WPA2
	Encryption algorithm: WEP64/WEP128/TKIP/AES
Network types	STA/AP

3.2. Radio Performance

3.2.1 IEEE802.11b

Table 4 Basic specifications under IEEE802.11b

ITEM	Specification
Modulation Type	DSSS / CCK
Frequency range	2412 MHz~ 2462 MHz
Channel	CH1 to CH11
Data rate	1, 2, 5.5, 11Mbps

Table 5 Transmitting performance under IEEE802.11b

TX Characteristics	Min.	Typical	Max.	Unit
Power@11Mbps	16		19	dBm
Frequency Error	-15		+15	ppm
EVM@11Mbps			-14	dB
Transmit spectrum mask				
Pass				

Table 6 Receiving performance under IEEE802.11b

RX Characteristics	Min	Typical	Max.	Unit
11Mbps Input Level Sensitivity				
Minimum Input Level (FER _≤ 8%)			-90	dBm

3.2.2. IEEE 802.11g

Table 7 Basic specifications under IEEE802.11g

ITEM	Specification
Modulation Type	OFDM
Frequency range	2412 MHz~ 2462 MHz
Channel	CH1 to CH11
Data rate	6, 9, 12, 18, 24, 36, 48, 54Mbps

Table 8 Transmitting performance under IEEE802.11g

TX Characteristics	Min.	Typical	Max.	Unit
Power@54Mbps	15		18	dBm
Frequency Error	-15		+15	ppm
EVM@54Mbps			-30	dB
Transmit spectrum mask				
Pass				

Table 9 Receiving performance under IEEE802.11g

RX Characteristics	Min	Typical	Max.	Unit
54Mbps Input Level Sensitivity				
Minimum Input Level (FER _≤ 10%)			-76	dBm

3.2.3 IEEE802.11n

IEEE802.11n 20MHz bandwidth mode

Table 10 Basic specifications under IEEE802.11n with 20MHz

ITEM	Specification
Modulation Type	OFDM
Frequency range	2412 MHz~ 2462 MHz
Channel	CH1 to CH11
Data rate	MCS0/1/2/3/4/5/6/7

Table 11 Transmitting performance under IEEE802.11n with 20MHz

TX Characteristics	Min.	Typical	Max.	Unit
Power@HT20, MCS7	14.5		17.5	dBm
Frequency Error	-15		+15	ppm
EVM@HT20, MCS7			-30	dB
Transmit spectrum mask				
Pass				

Table 12 Receiving performance under IEEE802.11n with 20MHz

RX Characteristics	Min	Typical	Ma x.	Unit
MCS7 Input Level Sensitivity				
Minimum Input Level (FER \leq 10%)			-73	dBm

4. BL3372-P Hardware Information

4.1. PIN Sequence

Please refer to Fig 1 for the pin sequence.

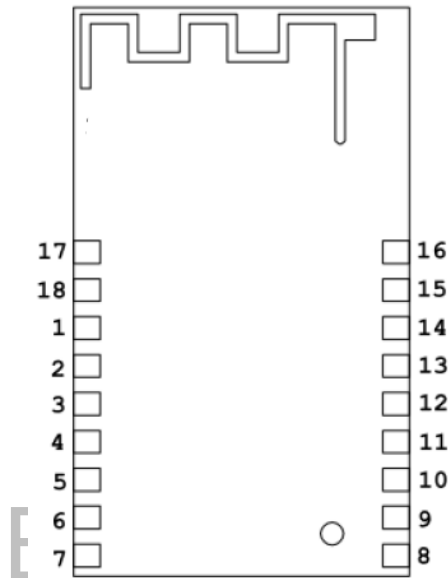

Fig 1 BL3372-P pin sequence

4.2. PIN Definitions

Please refer to Table 13 for pin definitions.

PIN	Function 1	Function 2	Function 3	Function 4	Function 5	Function 6
1	GDN					
2	VDD					
3	RST					
4	GPIO14	TX0				SD_INT
5	GPIO13	RX0				
6	GPIO16	TX2			SPI-SCL	SD_D3
7	GPIO15	RX2			SPI-CS	SD_D2
8	GPIO0		PWM0			
9	GPIO17		PWM5			SD_CMD
10	GPIO18		PWM6			SD_CLK

11	GPIO19		PWM7		SPI-MOSI	SD_D0
12	GPIO20		PWM0		SPI-MISO	SD_D1
13	VDD					
14	GND					
15	GPIO1		PWM1			
16	GPIO4		PWM4			
17	GPIO3	TX1	PWM2	I2C-SDA	SPI-SCL	
18	GPIO2	RX1	PWM3	I2C-SCL	SPI-CS	

Table 13 BL3372-P pin definitions

Note:

1. In default, UART0 (pin4 and pin5) are used for bypass communication and UART2 (pin6 and pin7) are used for output of debugging information and burning firmware. Please refer to the description in DC Characteristics for UART output current level.
2. RST is the reset pin and will be effective with VIL. Configuration information will be remained after module reset. The module has pull-up process for RST designed internally.
3. The pins for reset button and LED indication should be defined according to actual firmware and circuit
4. **GPIO0 and GPIO1 are hardware function pins and DO NOT pull up these two pins before power-up.**
5. Pulling up both GPIO0 and GPIO3 will switch the module to firmware programming mode.

4.3 Recommendations

The following precautions should be considered during PCB designing:

Do not place any electrical components or grounding in antenna area on main board and it's better to leave this area blank on PCB.

It is recommended to not place any electrical components within 10mm range of module antenna and not design any circuit or bond copper on main board under this area.

Do not use the module inside any metal case or containers with metal painting.

Keep the antenna of Wi-Fi module next to the edge of main board (as shown in Fig 5) during design of PCB to ensure better performance of antenna.

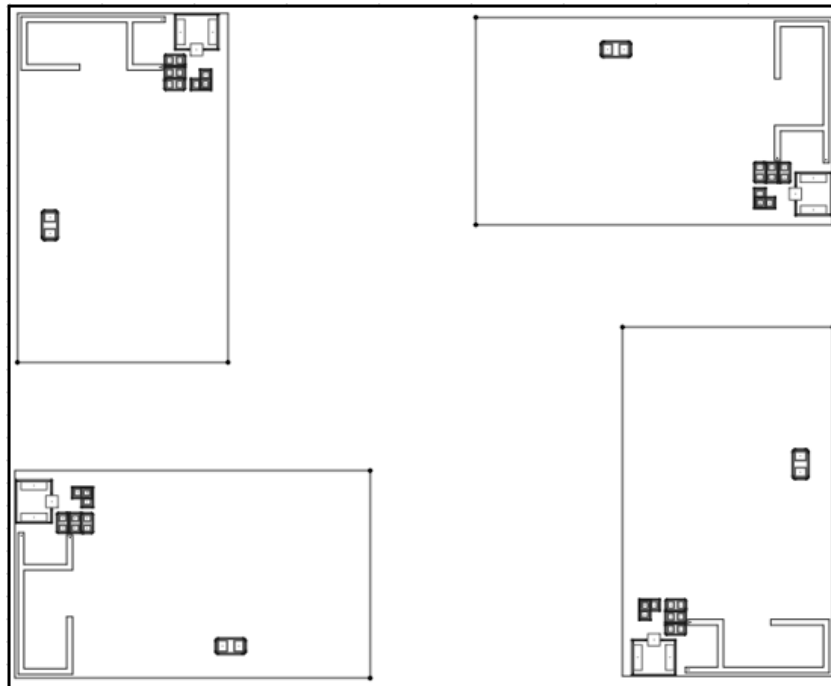

Fig 2 BL3372-P Recommended PCB layout

4.4. Mechanical Dimensions

BroadLink

Please refer to Fig 3 for the dimensions of module.

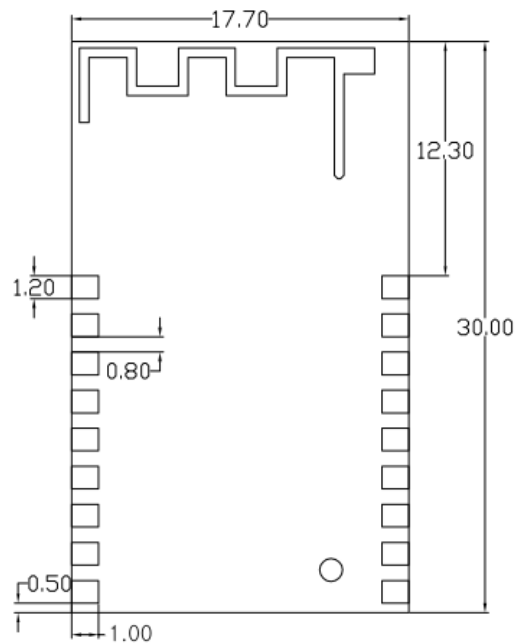

Fig 3 BL3372-P Module Dimensions

Note: Dimensions (17.7±0.2) mm * (30±0.2) mm * (3.6± 10%)mm (with shielding case)

4.5. Recommended Pad Size

Please refer to Fig 4 for the recommended pad size

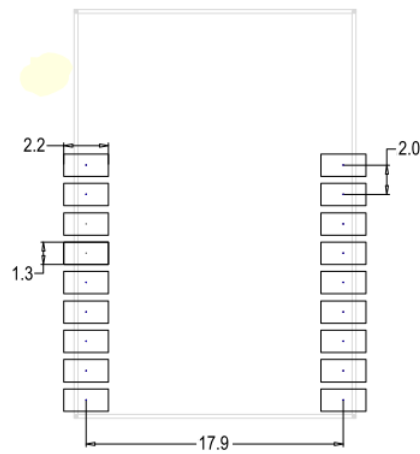

Fig 4 BL3372-P Recommended pad size

4.6. Certifications

1. Certified for SRRC standard
2. Compliant with requirement of RoHS 2.0.
3. Compliant with requirement of REACH.

4.7. Label



Fig 5 BL3372-P label content

Please refer to Fig 8 for the content description on label.

Model: *****: Module model

SN: 00ACA3FE75D7: Module unique MAC address

QR code: Model No. BL3372-P, MAC, CMIIT ID and other info

4.7. Shielding Case Dimensions

Please refer to Fig 6 for the dimensions of shielding case.

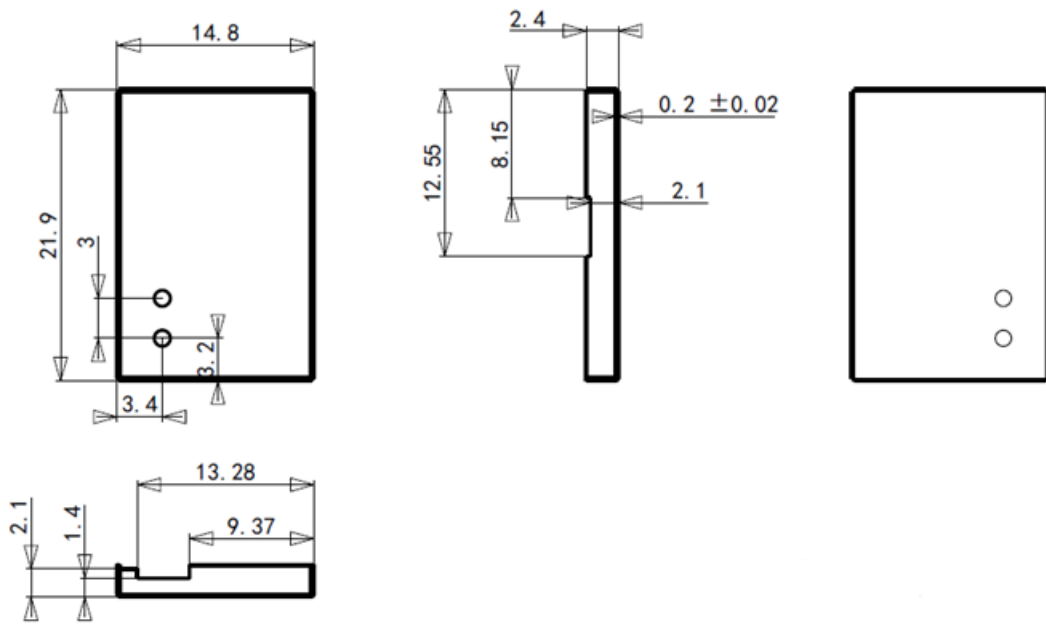

(Unit: mm)

Fig 6 BL3372-P Dimensions of shielding case

4.8. Packaging BroadLink

Please refer to Fig 7 and Fig 8 for the details of packaging.

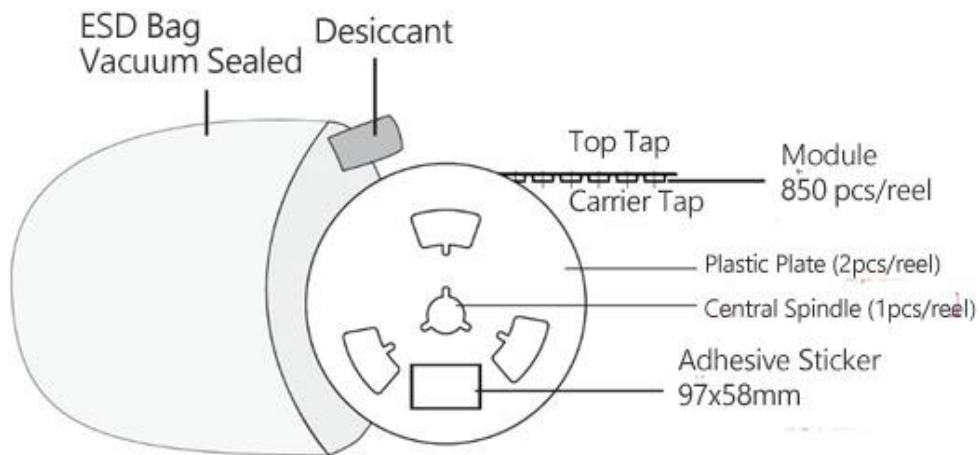
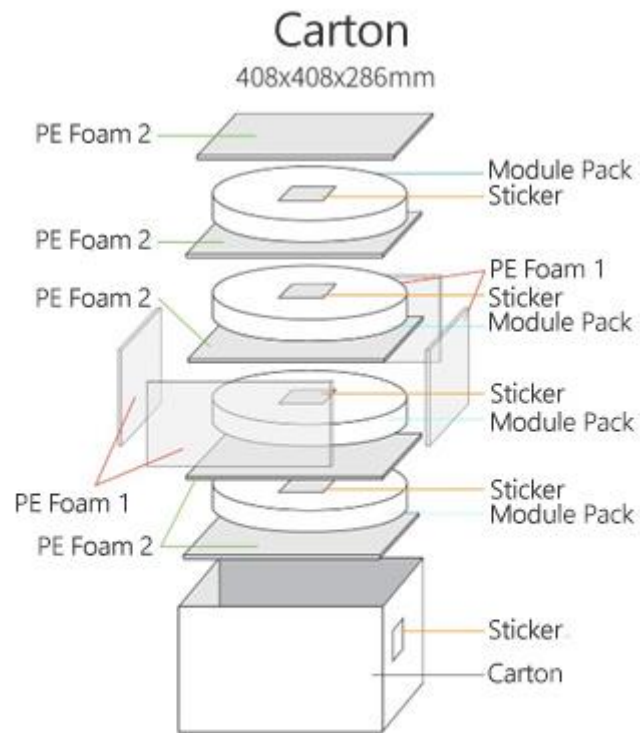

Fig 7 Packaging



Note: Stick size 80x80mm on each module pack (4pcs/ctn)

BROADLINK
Fig 8 Carton

BL3372-P is packed in reel with 850 pcs/reel.

5. Reference Design

5.1. UART Interface Design

For devices with 3.3V power supply, you can directly connect the device UART port with module UART port according to the illustration in Fig 12.

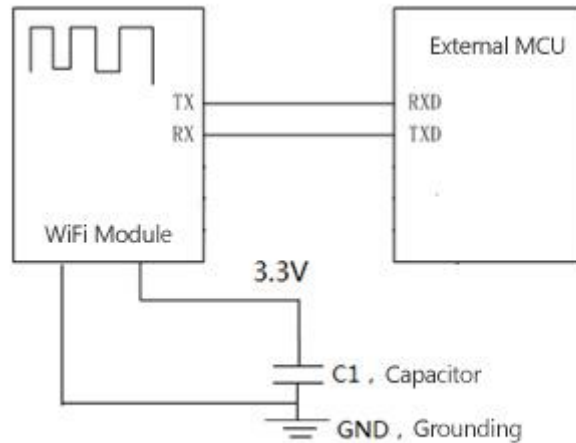

Fig 9 Circuit diagram (3.3V)

If your device is powered by 5V, you can refer to the circuit shown in Fig 10 or design your own circuit for power conversion. The value of resistor can be adjusted according to actual circuit design.

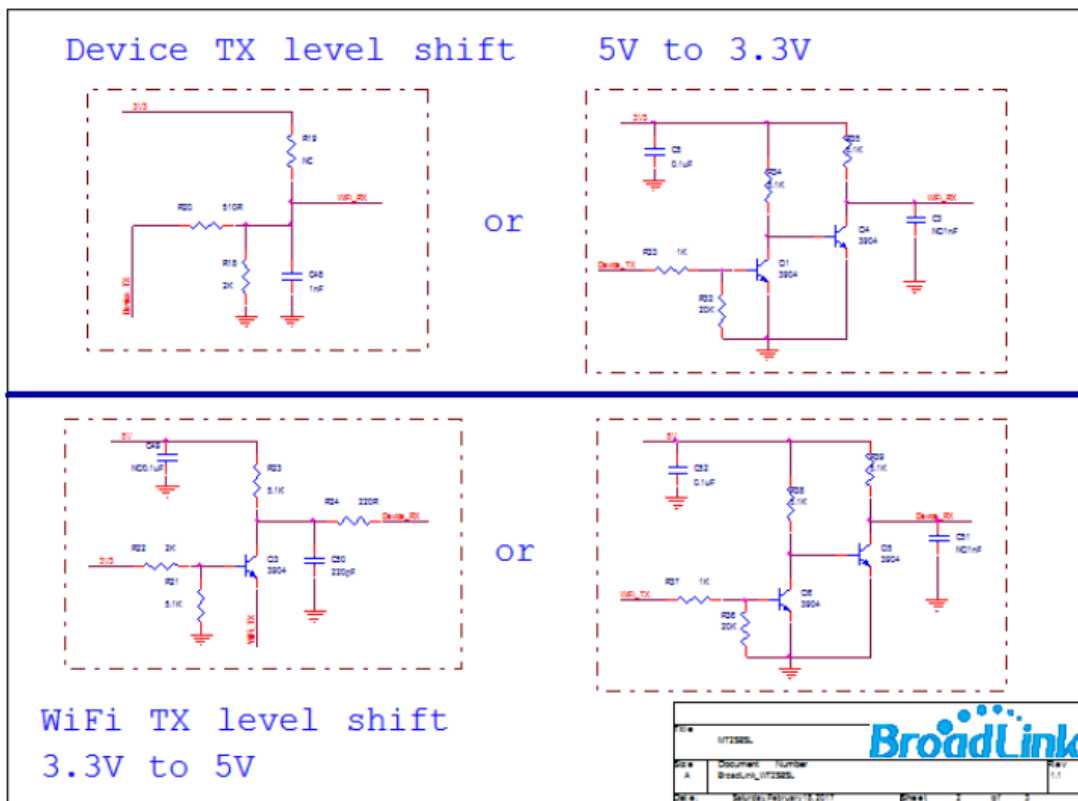

Fig 10 Circuit diagram (5V)

5.2. Power Supply Requirement

If an LDO is used to supply the module with 3.3V power, C1 capacitor can be used with 10uF-22uF; If a DCDC is used to supply 3.3V power, C1 capacitor can be used with 22uF.

It is recommended to supply the module with power higher than 400mA to ensure enough power supply to the module and avoid power down during data.

The module is designed with 2x 3.3V pins. You can power the module with either pin or both pins.

BroadLink

Revision History

Date	Version	Updated Content
1/7/2021	1.0	Preliminary version
3/1/2022	1.1	Added some electrical parameters
6/28/2022	1.2	Added IO multiplexing SDIO definition
7/1/2022	1.3	Added IO multiplexing SPI definition
8/25/2022	1.4	Add 4MB Flash spec option

Copyrights

It is prohibited to use or copy all or any part of contents in this manual without prior permission, especially applicable for trademarks, models, part numbers and figures.

Contact Us



Ms Zhou

Hangzhou BroadLink Technology Co., Ltd.

Add: Building C, 57 Jiang'er Road, Binjiang District, Hangzhou, P.R.China Postcode: 310052

Tel: +86-571-85071744-8010

Email: bingqi.zhou@broadlink.com.cn

For more information of BroadLink Wi-Fi modules, please visit our website:
www.broadlink.com.cn

FCC Warning

This device complies with Part 15 of the FCC Rules. Operation is subject to the following two conditions:

(1) This device may not cause harmful interference, and (2) this device must accept any interference received, including interference that may cause undesired operation.

NOTE 1: Any changes or modifications to this unit not expressly approved by the party responsible for compliance could void the user's authority to operate the equipment.

FCC Radiation Exposure Statement:

This equipment complies with FCC radiation exposure limits set forth for an uncontrolled environment. End users must follow the specific operating instructions for satisfying RF exposure compliance.

Note 1: This module certified that complies with RF exposure requirement under mobile or fixed condition, this module is to be installed only in mobile or fixed applications.

A mobile device is defined as a transmitting device designed to be used in other than fixed locations and to generally be used in such a way that a separation distance of at least 20 centimeters is normally maintained between the transmitter's radiating structure(s) and the body of the user or nearby persons. Transmitting devices designed to be used by consumers or workers that can be easily re-located, such as wireless devices associated with a personal computer, are considered to be mobile devices if they meet the 20 centimeter separation requirement.

A fixed device is defined as a device is physically secured at one location and is not able to be easily moved to another location.

Note 2: Any modifications made to the module will void the Grant of Certification, this module is limited to OEM installation only and must not be sold to end-users, end-user has no manual instructions to remove or install the device, only software or operating procedure shall be placed in the end-user operating manual of final products.

Note 3: Additional testing and certification may be necessary when multiple modules are used.

Note 4: The module may be operated only with the antenna with which it is authorized. Any antenna that is of the same type and of equal or less directional gain as an antenna

that is authorized with the intentional radiator may be marketed with, and used with, that intentional radiator.

Note 5: To ensure compliance with all non-transmitter functions the host manufacturer is responsible for ensuring compliance with the module(s) installed and fully operational. For example, if a host was previously authorized as an unintentional radiator under the Supplier's Declaration of Conformity procedure without a transmitter certified module and a module is added, the host manufacturer is responsible for ensuring that after the module is installed and operational the host continues to be compliant with the Part 15B unintentional radiator requirements. Since this may depend on the details of how the module is integrated with the host, Hangzhou BroadLink Technology Co., Ltd. shall provide guidance to the host manufacturer for compliance with the Part 15B requirements.

Note 6: FCC ID label on the final system must be labeled with "Contains FCC ID: 2ATEV-BL3372-P" or "Contains transmitter module FCC ID: 2ATEV-BL3372-P".

Note 7: For all products market in US, OEM has to limit the operation channels in CH1 to CH11 for 2.4G band by supplied firmware programming tool. OEM shall not supply any tool or info to the end-user regarding to Regulatory Domain change.

IC WARNING



This device contains licence-exempt transmitter(s) that comply with Innovation, Science and Economic Development Canada's licence-exempt RSS(s). Operation is subject to the following two conditions:

- (1) This device may not cause interference.
- (2) This device must accept any interference, including interference that may cause undesired operation of the device.

L'émetteur/récepteur exempt de licence contenu dans le présent appareil est conforme aux CNR d'Innovation, Sciences et Développement économique Canada applicables aux appareils radio exempts de licence. L'exploitation est autorisée aux deux conditions suivantes:

1. L'appareil ne doit pas produire de brouillage;
2. L'appareil doit accepter tout brouillage radioélectrique subi, même si le brouillage est susceptible d'en compromettre le fonctionnement.

IC Radiation Exposure Statement:

This device and its antenna(s) must not be co-located with any other transmitters except in accordance with IC multi-transmitter product procedures. Referring to the multi-transmitter policy, multiple-transmitter(s) and module(s) can be operated

simultaneously without reassessment permissive change.

Cet appareil et son antenne (s) ne doit pas être co-localisés ou fonctionnement en association avec une autre antenne ou transmetteur.

This equipment complies with IC RSS-102 radiation exposure limits set forth for an uncontrolled environment. This equipment should be installed and operated with minimum distance 20cm between the radiator & your body.

Cet équipement est conforme aux limites d'exposition aux rayonnements IC établies pour un environnement non contrôlé. Cet équipement doit être installé et utilisé avec un minimum de 20cm de distance entre la source de rayonnement et votre corps.

This module is limited to OEM installation only and must not be sold to end-users, end-user has no manual instructions to remove or install the device, only software or operating procedure shall be placed in the end-user operating manual of final products. Additional testing and certification may be necessary when multiple modules are used.

Any changes or modifications not expressly approved by the manufacturer could void the user's authority to operate this equipment.

The final end product must be labeled in a visible area with the following " Contains IC: 25062-BL3372P ".
