

BL3394-P/EL3394-P

Embedded
WiFi/BT Module

Product

Version: 1.4

Release date: 8/10/2023

Features

- Cortex-M33+Cortex-M23 dual core
- 512KBSRAM/4MBpSRAM
- External 4MB FLASH
- Support AES/DES/SHA1
- Support XIP
- Working voltage: DC3.3V
- Support BLE5.0
- Wi-Fi related features
 - Support 802.11 b/g/n standards
 - Support station and softAP
 - Support SmartConfig and AP configuration
 - Support WEP/WPA2
 - Support multiple cloud services
 - Integrated balun/PA/LNA
 - TCP/IP stack optimized for IoT application
 - PCB antenna
- Peripherals:
 - 2xUART
 - 9xGPIOs
- Working temperature: 0°C to +85°C
- Stamp-style package for SMT soldering

Applications

- Smart transportation
- Smart home / appliances
- Instruments
- Health care
- Industrial automation
- Intelligent security
- Smart energy

Model

Model	Antenna type	Note
BL3394-P	PCB antenna	Default
EL3394-P	PCB antenna	Default

Content

1. Overview.....	- 3 -
2. Basic Specifications.....	- 3 -
2.1. Power Consumption	- 3 -
2.2. Working Environment	- 4 -
3. Radio Specifications.....	- 4 -
3.1. Basic Radio Specification	- 4 -
3.2. Radio Performance	- 5 -
3.2.1. IEEE802.11b	- 5 -
3.2.2. IEEE 802.11g	- 6 -
3.2.3 IEEE802.11n	- 7 -
4. Hardware Information.....	- 8 -
4.1. PIN Sequence.....	- 8 -
4.2. PIN Definitions.....	- 9 -
4.3 Recommendations.....	- 10 -
4.4. Mechanical Dimensions.....	- 11 -
4.5. Recommended Pad Size	- 11 -
4.6. Certifications	- 12 -
4.7. Mechanical Dimensions.....	- 12 -
4.8. Packaging.....	- 13 -
5. Reference Design.....	- 14 -
5.1. UART Interface Design.....	- 14 -
5.2. Power Supply Requirement.....	- 16 -
Revision History.....	- 21 -
Copyrights.....	- 21 -
Contact Us	- 21 -

1. Overview

BL3394-P/EL3394-P is an embedded Wi-Fi module designed by BroadLink, highly integrated with Cortex-M33+Cortex-M23 dual core MCU with 512KB SRAM + 4MB pSRAM, 4MB external flash, with 3.3V power supply.

The module integrates radio transceiver, MAC, baseband, all Wi-Fi protocols, configurations, and network stack. It can be widely used in applications like smart home devices, remote monitoring devices and medical care instruments.

2. Basic Specifications

2.1. Power Consumption

Please refer to Table 1 for power consumption data.

Table 1 - Power Consumption Data

Specifications	Min.	Typ.	Max.	Units
VDD	3.0	3.3	3.6	V
VIL (input low voltage)			0.3VCC	V
VIH (input high voltage)	0.7VCC		3.6	V
VOL (output low voltage)			0.4	V
VOH (output high voltage)	2.4		3.6	V
RX		60		mA
pulse current @TX 11b @17.5dBm 11Mbps		310		mA
pulse current @TX 11g @16.5dBm 54Mbps		295		mA
pulse current @TX 11n @16dBm HT20 MCS7		288		mA

pulse current @TX 11n @15dBm HT40 MCS7		270		mA
pulse current @BLE @6dBm		155		mA

2.2. Working Environment

Please refer to Table 2 for working environment data.

Table 2 - Working Environment Data

Symbol	Description	Min.	Max.	Units
Ts	Storage temperature	-40	125	°C
TA	Ambient operating temperature	0	85	°C
Vdd	Supply voltage	3.0	3.6	V
Vio	Voltage on IO pin	0	3.6	V

3. Radio Specifications

3.1. Basic Radio Specification

Please refer to Table 3 for radio specification.

Table 3 - Radio Specification

	CE	FCC/IC
Radio range	2.402 GHz - 2.480 GHz	2.402 GHz - 2.480 GHz
Wireless standards	IEEE 802.11 b/g/n	IEEE 802.11 b/g/n
Radio output (conductive)	802.11b:17 ± 1.5dBm@11Mbps	802.11b:15.5 ± 1.5dBm@11Mbps
	802.11g:16 ± 1.5dBm@54Mbps	802.11g:14.5 ± 1.5dBm@54Mbps
	802.11n:15.5 ± 1.5dBm@MCS7/HT20	802.11n:13.5 ± 1.5dBm@MCS7/HT20
	802.11n:15.5 ± 1.5dBm@MCS7/HT40	802.11n:12.5 ± 1.5dBm@MCS7/HT40
	BLE:6 ± 2dBm	BLE:4 ± 2dBm
Antenna type	Internal: PCB antenna	Internal: PCB antenna
	External: Not supported	External: Not supported
	802.11b ≦ -90dBm@11Mbps	802.11b ≦ -90dBm@11Mbps

Receiving sensitivity	802.11g \leq -76dBm@54Mbps	802.11g \leq -76dBm@54Mbps
	802.11n/HT20 \leq -73dBm@MCS7	802.11n/HT20 \leq -73dBm@MCS7
	802.11n/HT40 \leq -70dBm@MCS7	802.11n/HT40 \leq -70dBm@MCS7
	BLE \leq -98dBm	BLE \leq -98dBm
Data rate (max)	11M@802.11b, 54M@802.11g, MCS7@802.11n	11M@802.11b, 54M@802.11g, MCS7@802.11n
Security	Encryption standard: Open/WPA/WPA2	Encryption standard: Open/WPA/WPA2
Network types	STA/AP	STA/AP

3.2. Radio Performance

3.2.1. IEEE802.11b

Table 4 - Basic specifications under IEEE802.11b

ITEM	Specification CE	Specification FCC/IC
Modulation Type	DSSS / CCK	DSSS / CCK
Frequency range	2412MHz~2472MHz	2412MHz~2462MHz
Channel	CH1 to CH13	CH1 to CH11
Data rate	1, 2, 5.5, 11Mbps	1, 2, 5.5, 11Mbps

Table 5 - Transmitting performance under IEEE802.11b

TX Characteristics	Min.	Typical	Max.	Unit
Power@11Mbps	16		19	dBm
Frequency Error	-15		+15	ppm
EVM@11Mbps			-14	dB
Transmit spectrum mask				
Pass				

Table 6 - Receiving performance under IEEE802.11b

RX Characteristics	Min	Typical	Max.	Unit
--------------------	-----	---------	------	------

11Mbps Input Level Sensitivity				
Minimum Input Level (FER ≅ 8%)			-90	dBm

3.2.2. IEEE 802.11g

Table 7 - Basic specifications under IEEE802.11g

ITEM	Specification CE	Specification FCC/IC
Modulation Type	OFDM	OFDM
Frequency range	2412MHz~2472MHz	2412MHz~2462MHz
Channel	CH1 to CH13	CH1 to CH11
Data rate	6, 9, 12, 18, 24, 36, 48, 54Mbps	6, 9, 12, 18, 24, 36, 48, 54Mbps

Table 8 - Transmitting performance under IEEE802.11g

TX Characteristics	Min.	Typical	Max.	Unit
Power@54Mbps	15		18	dBm
Frequency Error	-15		+15	ppm
EVM@54Mbps			-30	dB
Transmit spectrum mask				
Pass				

Table 9 - Receiving performance under IEEE802.11g

RX Characteristics	Min	Typical	Max.	Unit
54Mbps Input Level Sensitivity				
Minimum Input Level (FER ≅ 10%)			-76	dBm

3.2.3 IEEE802.11n

IEEE802.11n 20MHz bandwidth mode

Table 10 - Basic specifications under IEEE802.11n with 20MHz

ITEM	Specification CE	Specification FCC/IC
Modulation Type	OFDM	OFDM
Frequency range	2412MHz~2472MHz	2412MHz~2462MHz
Channel	CH1 to CH13	CH1 to CH11
Data rate	MCS0/1/2/3/4/5/6/7	MCS0/1/2/3/4/5/6/7

Table 11 - Transmitting performance under IEEE802.11n with 20MHz

TX Characteristics	Min.	Typical	Max.	Unit
Power@HT20, MCS7	14.5		17.5	dBm
Frequency Error	-15		+15	ppm
EVM@HT20, MCS7			-30	dB
Transmit spectrum mask				
Pass				

Table 12 - Receiving performance under IEEE802.11n with 20MHz

RX Characteristics	Min.	Typical	Max.	Unit
MCS7 Input Level Sensitivity				
Minimum Input Level (FER ≦ 10%)			-73	dBm

IEEE802.11n 40MHz bandwidth mode

Table 13 - Basic specifications under IEEE802.11n with 40MHz

ITEM	Specification CE	Specification FCC/IC
Modulation Type	OFDM	OFDM

Frequency range	2422MHz~2462MHz	2422MHz~2452MHz
Channel	CH1 to CH9	CH1 to CH7
Data rate	MCS0/1/2/3/4/5/6/7	MCS0/1/2/3/4/5/6/7

Table 14 - Transmitting performance under IEEE802.11n with 40MHz

TX Characteristics	Min.	Typical	Max.	Unit
Power@HT20, MCS7	13.5		17	dBm
Frequency Error	-15		+15	ppm
EVM@HT40, MCS7			-30	dB
Transmit spectrum mask				
Pass				

Table 15 - Receiving performance under IEEE802.11n with 40MHz

RX Characteristics	Min.	Typical	Max.	Unit
MCS7 Input Level Sensitivity				
Minimum Input Level (FER \leq 10%)			-70	dBm

4. BL3394-P Hardware Information

4.1. PIN Sequence

Please refer to Fig 1 for the pin sequence.

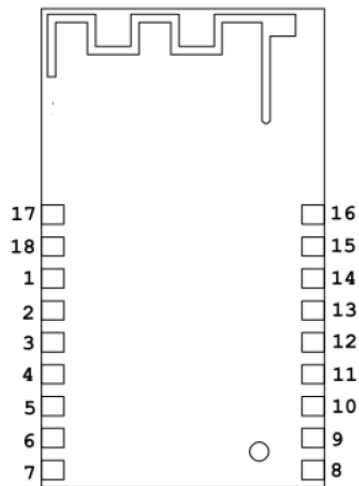

Fig 1 - pin sequence

4.2. PIN Definitions

Please refer to Table 13 for pin definitions.

PIN	Function 1	Function 2	Function 3
1	GDN		
2	VDD		
3	RST		
4	PA18	HS_UART0_TX	
5	PA19	HS_UART0_RX	
6	PA7	LOG_TX	
7	PA8	LOG_RX	
8	PB22		HS_PWM14
9	PB23		HS_PWM15
10	PB26		
11	PB29		
12	PB31		
13	VDD		
14	GND		
15	PB2	LP_UART_RX	
16	PB1	LP_UART_TX	
17	PA26		HS_PWM5
18	PA25		HS_PWM4

Table 16 - Pin Definitions

Note:

1. In default, HS_UART0 (pin4 and pin5) are used for transparent communication and UART_LOG (pin6 and pin7) is used for output of debugging information and burning firmware. Please refer to the description in DC Characteristics for UART output current level.
2. RST is the reset pin and will be effective with VIL. Configuration information will be remained after module reset. The module has pull-up process for RST designed internally.
3. The pins for reset button and LED indication should be defined according to actual firmware and circuit.
4. Pulling down PA7 will switch the module to firmware programming mode.

4.3 Recommendations

The following precautions should be considered during PCB designing:

Do not place any electrical components or grounding in antenna area on main board and it's better to leave this area blank on PCB.

It is recommended to not place any electrical components within 10mm range of module antenna and not design any circuit or bond copper on main board under this area.

Do not use the module inside any metal case or containers with metal painting.

Keep the antenna of Wi-Fi module next to the edge of main board (as shown in Fig 5) during design of PCB to ensure better performance of antenna.

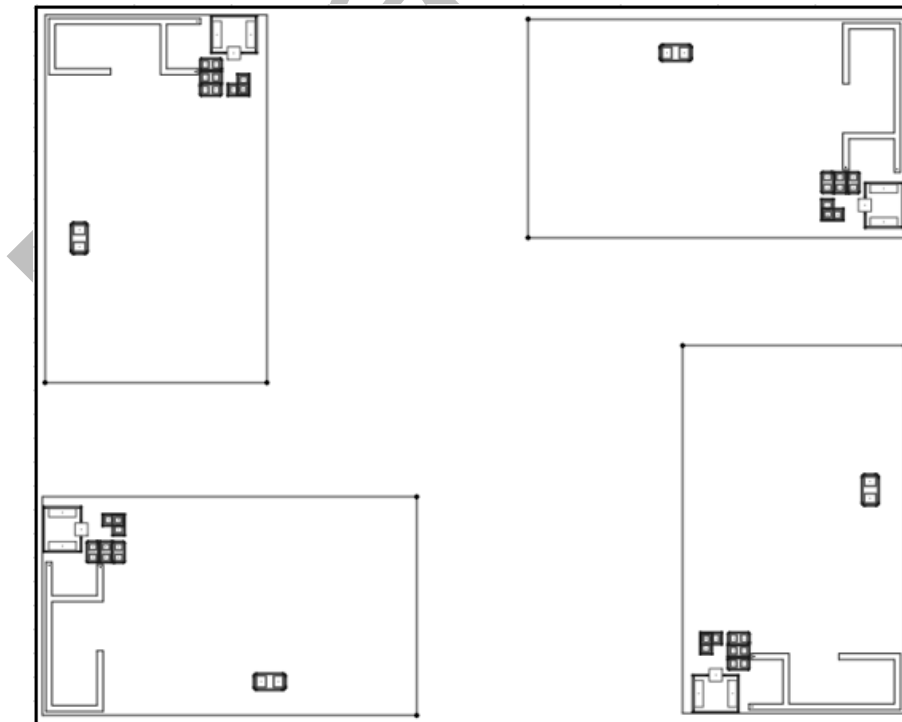

Fig 2 - Recommended PCB Layout

4.4. Mechanical Dimensions

Please refer to Fig 3 for the dimensions of module.

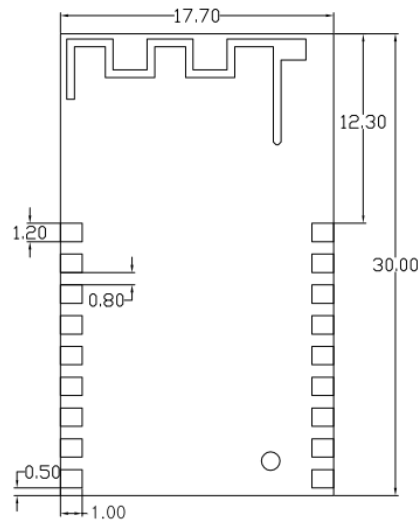

Fig 3 - Module Dimensions

Note: Dimensions (17.7 ± 0.2) mm * (30 ± 0.2) mm * $(3.6 \pm 10\%)$ mm (with shielding case)

4.5. Recommended Pad Size

Please refer to Fig 4 for the recommended pad size

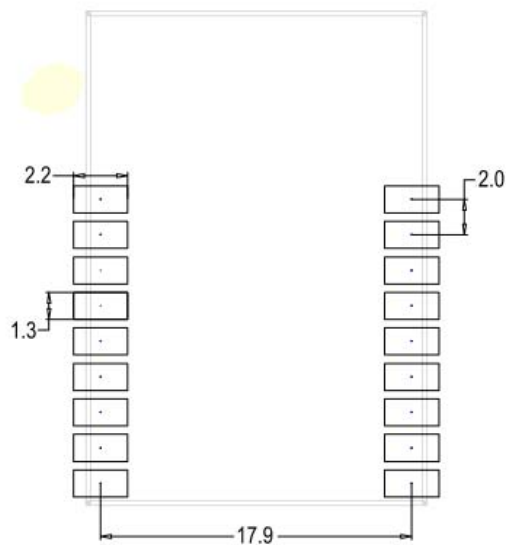

Fig 4 - Recommended Pad Size

4.6. Certifications

1. Certified for SRRC standard
2. Compliant with requirement of RoHS 2.0.
3. Compliant with requirement of REACH.

4.7. Mechanical Dimensions

Please refer to Fig 6 for the dimensions of shielding case.

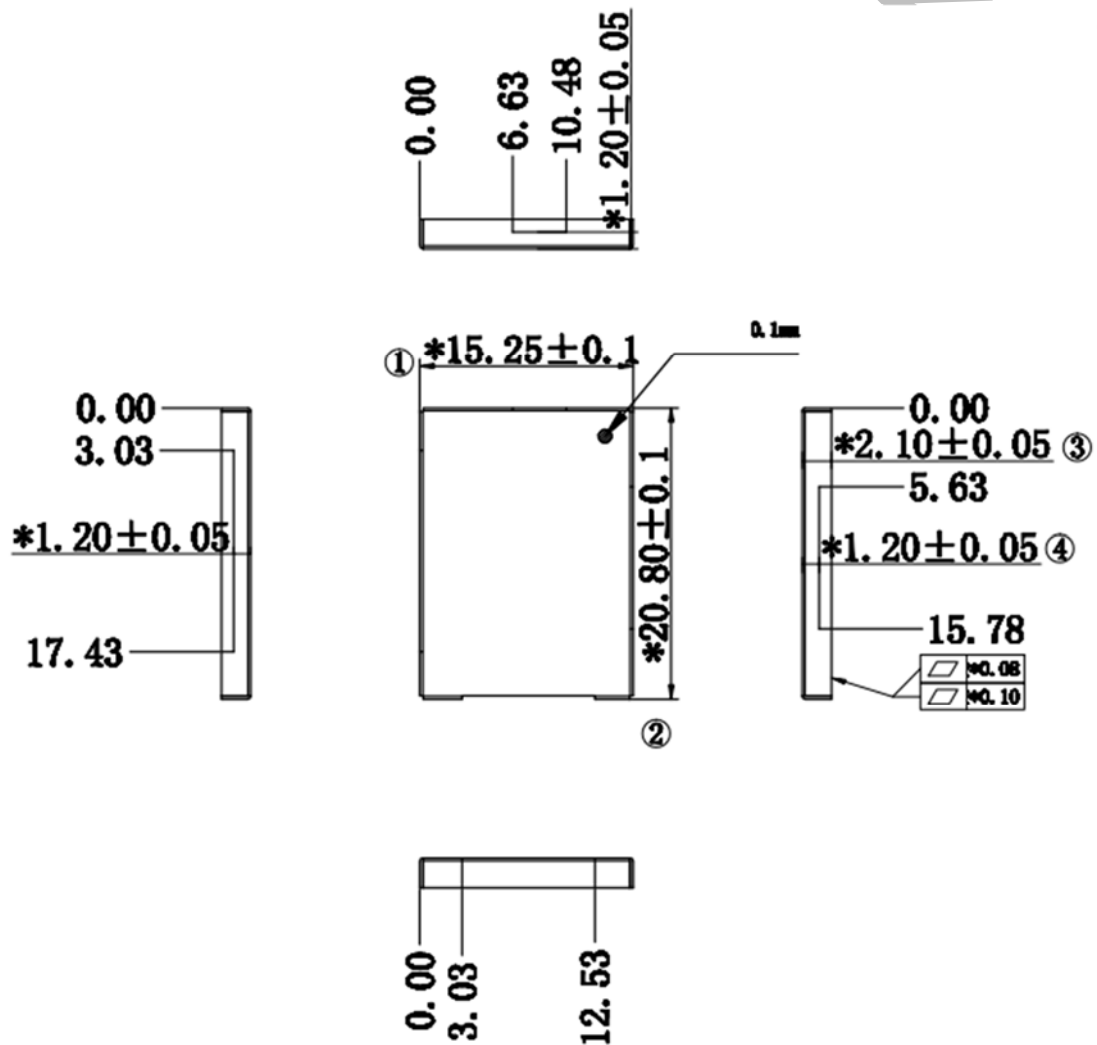

Fig 6 - Dimensions of Shielding Case

(Unit: mm)

4.8. Packaging

Please refer to Fig 7 and Fig 8 for the details of packaging.

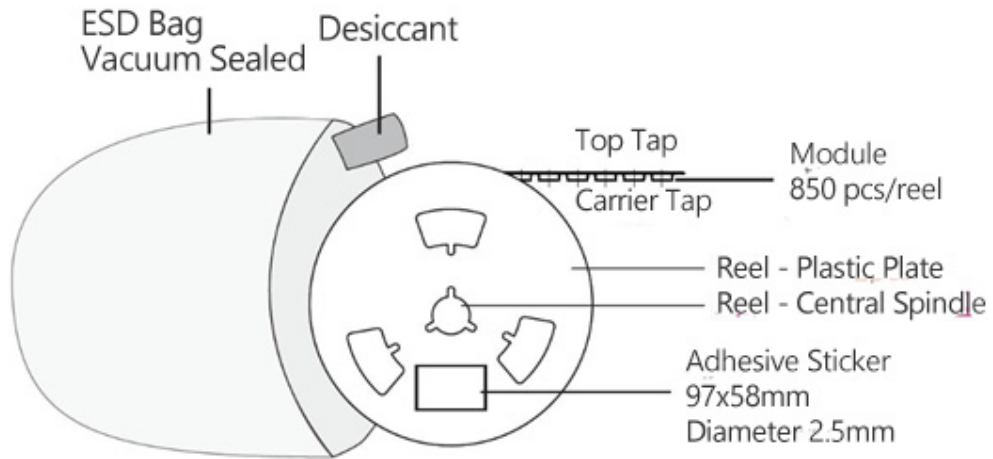
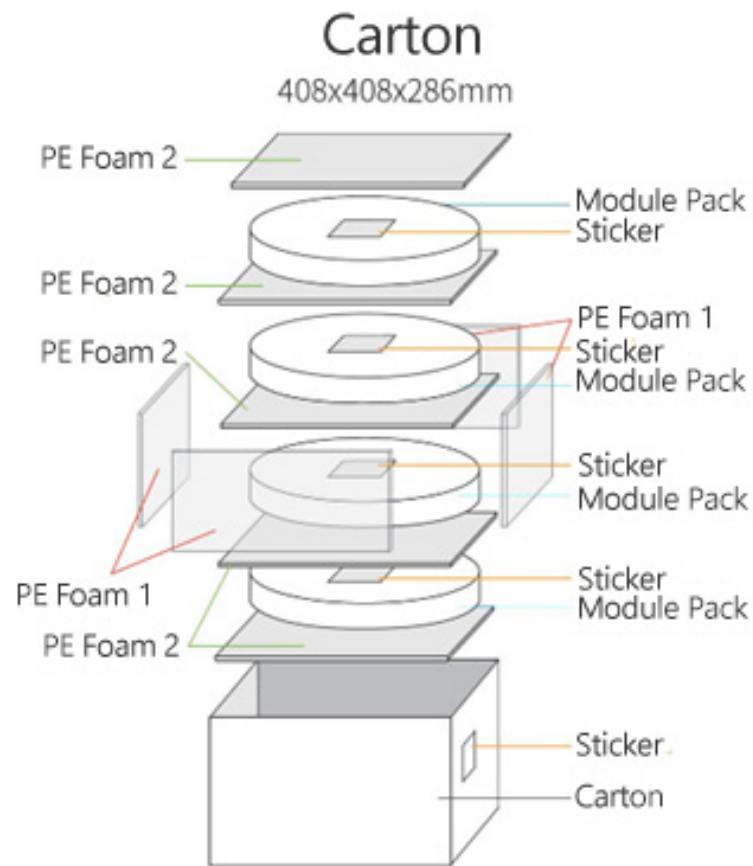

Fig 7 Packaging

BroadLink



Note: Stick size 97x58mm on each module pack (4pcs/ctn)

Fig 8 - Carton

Is packed in reel with 850 pcs/reel.

5. Reference Design

5.1. UART Interface Design

For devices with 3.3V power supply, you can directly connect the device UART port with module UART port according to the illustration in Fig 12.

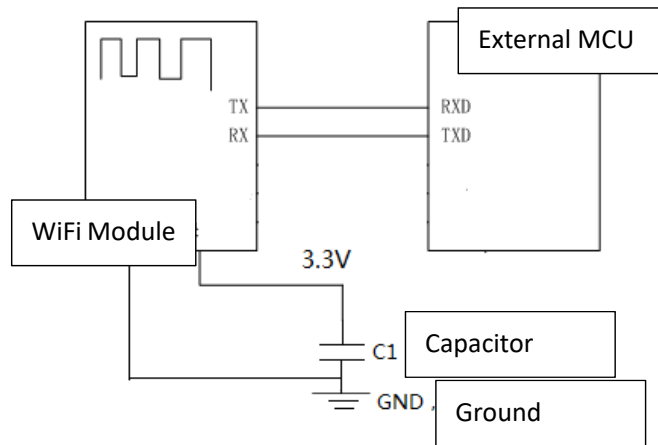

Fig 9 - Circuit Diagram (3.3V)

If your device is powered by 5V, you can refer to the circuit shown in Fig 10 or design your own circuit for power conversion. The value of resistor can be adjusted according to actual circuit design.

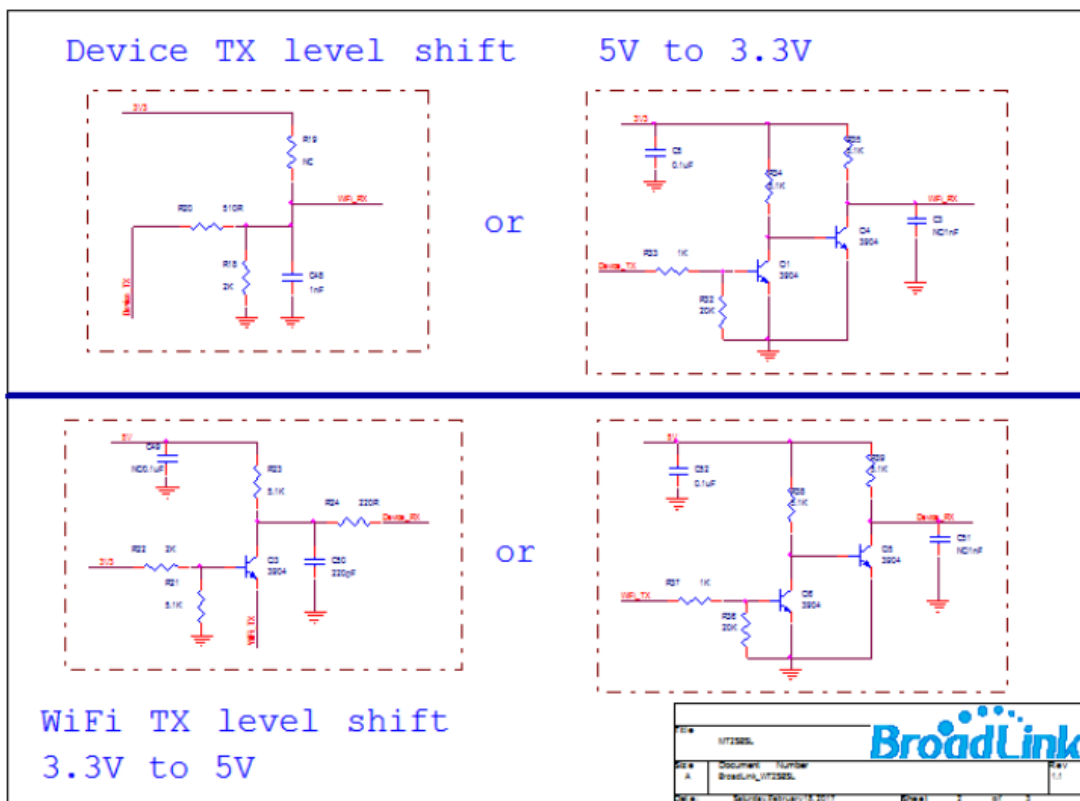

Fig 10 - Circuit Diagram (5V)

5.2. Power Supply Requirement

If an LDO is used to supply the module with 3.3V power, C1 capacitor can be used with 10uF-22uF;

If a DCDC is used to supply 3.3V power, C1 capacitor can be used with 22uF.

Please ensure that the power supply can provide a sufficiently large current. During the DPD phase, the module will experience consecutive pulses with a duration of approximately 50us. It is recommended that the power supply be capable of providing a pulse current of at least 800mA. During the normal operation of the module in the data transmission phase, the power supply should be able to sustain a current of at least 500mA.

The module is designed with 2x 3.3V pins. You can power the module with either pin or both pins.

CE Warning

Caution:

Use the Product in the environment with the temperature Between 0°C and 85°C; Otherwise, it may damage your product. Products can only be used below 2000m altitude

For the following equipment:

Product Name: WiFi/BT Module

Brand Name: ---

Model No.: BL3394-P, EL3394-P

Hangzhou BroadLink Technology Co., Ltd.

E-mail: mengjiao.yan@broadlink.com.cn

Hereby declares that this [Name: WiFi/BT Module, Model: BL3394-P, EL3394-P] is in compliance with the essential requirements and other relevant provisions of Directive 2014/53/EU.



This product is intended for sale and application in a business environment.

RED Article 10 2

-This product can be used across EU member states

RED Article 10 10

-The product is class 1 product, No restrictions

The RF distance between body and product is 20cm

Wi-Fi

Support Standards: 802.11b, 802.11g, 802.11n-HT20/40

Frequency Range: 2412-2472MHz for 802.11b/g/n (HT20); 2422-2462MHz for 802.11n (HT40)

Max.RF Output Power: 18.15dBm (EIRP)

Bluetooth

Bluetooth Version: Bluetooth V5.0 (BLE Mode)

Frequency Range: 2402-2480MHz

Max.RF Output Power: 1Mbps: 7.61dBm (EIRP); 2Mbps: 7.68dBm (EIRP)

FCC Warning**List of applicable FCC rules**

FCC Part 15.247

Label and compliance information

FCC ID label on the final system must be labeled with "Contains FCC ID: 2ATEV-3394-P" or "Contains transmitter module FCC ID: 2ATEV-3394-P".

Information on test modes and additional testing requirements

Contact Hangzhou BroadLink Technology Co., Ltd. will provide stand-alone modular transmitter test mode. Additional testing and certification may be necessary when multiple modules are used in a host.

Additional testing, Part 15 Subpart B disclaimer

To ensure compliance with all non-transmitter functions the host manufacturer is responsible for ensuring compliance with the module(s) installed and fully operational. For example, if a host was previously authorized as an unintentional radiator under the Supplier's Declaration of Conformity procedure without a transmitter certified module and a module is added, the host manufacturer is responsible for ensuring that after the module is installed and operational the host continues to be compliant with the Part 15B unintentional radiator requirements. Since this may depend on the details of how the module is integrated with the host, Hangzhou BroadLink Technology Co., Ltd. shall provide guidance to the host manufacturer for compliance with the Part 15B requirements.

This device complies with Part 15 of the FCC Rules. Operation is subject to the following two conditions:

(1) This device may not cause harmful interference, and (2) this device must accept any interference received, including interference that may cause undesired operation.

NOTE 1: Any changes or modifications to this unit not expressly approved by the party responsible for compliance could void the user's authority to operate the equipment.

FCC Radiation Exposure Statement:

This equipment complies with FCC radiation exposure limits set forth for an uncontrolled environment. End users must follow the specific operating instructions for satisfying RF exposure compliance.

Note 1: This module certified that complies with RF exposure requirement under mobile or fixed condition, this module is to be installed only in mobile or fixed applications.

A mobile device is defined as a transmitting device designed to be used in other than fixed locations and to generally be used in such a way that a separation distance of at least 20

centimeters is normally maintained between the transmitter's radiating structure(s) and the body of the user or nearby persons. Transmitting devices designed to be used by consumers or workers that can be easily re-located, such as wireless devices associated with a personal computer, are considered to be mobile devices if they meet the 20 centimeter separation requirement.

A fixed device is defined as a device is physically secured at one location and is not able to be easily moved to another location.

Note 2: Any modifications made to the module will void the Grant of Certification, this module is limited to OEM installation only and must not be sold to end-users, end-user has no manual instructions to remove or install the device, only software or operating procedure shall be placed in the end-user operating manual of final products.

Note 3: The module may be operated only with the antenna with which it is authorized. Any antenna that is of the same type and of equal or less directional gain as an antenna that is authorized with the intentional radiator may be marketed with, and used with, that intentional radiator.

Note 4: For all products market in US, OEM has to limit the operation channels in CH1 to CH11 for 2.4G band by supplied firmware programming tool. OEM shall not supply any tool or info to the end-user regarding to Regulatory Domain change.

IC WARNING

This device contains licence-exempt transmitter(s) that comply with Innovation, Science and Economic Development Canada's licence-exempt RSS(s). Operation is subject to the following two conditions:

- (1) This device may not cause interference.
- (2) This device must accept any interference, including interference that may cause undesired operation of the device.

L'émetteur/récepteur exempt de licence contenu dans le présent appareil est conforme aux CNR d'Innovation, Sciences et Développement économique Canada applicables aux appareils radio exempts de licence. L'exploitation est autorisée aux deux conditions suivantes:

1. L'appareil ne doit pas produire de brouillage;
2. L'appareil doit accepter tout brouillage radioélectrique subi, même si le brouillage est susceptible d'en compromettre le fonctionnement.

IC Radiation Exposure Statement:

This device and its antenna(s) must not be co-located with any other transmitters except in accordance with IC multi-transmitter product procedures. Referring to the multi-transmitter policy, multiple-transmitter(s) and module(s) can be operated simultaneously without

reassessment permissive change.

Cet appareil et son antenne (s) ne doit pas être co-localisés ou fonctionner en association avec une autre antenne ou transmetteur.

This equipment complies with IC RSS-102 radiation exposure limits set forth for an uncontrolled environment. This equipment should be installed and operated with minimum distance 20cm between the radiator & your body.

Cet équipement est conforme aux limites d'exposition aux rayonnements IC établies pour un environnement non contrôlé. Cet équipement doit être installé et utilisé avec un minimum de 20cm de distance entre la source de rayonnement et votre corps.

This module is limited to OEM installation only and must not be sold to end-users, end-user has no manual instructions to remove or install the device, only software or operating procedure shall be placed in the end-user operating manual of final products. Additional testing and certification may be necessary when multiple modules are used.

Any changes or modifications not expressly approved by the manufacturer could void the user's authority to operate this equipment.

The final end product must be labeled in a visible area with the following " Contains IC: 25062-3394P".

Revision History

Date	Version	Updated Content
4/20/2023	1.0	Preliminary version
5/22/2023	1.1	Added some electrical parameters
6/20/2023	1.2	Changed current value and IO ports
7/4/2023	1.3	Added shielding, BLE packet transmission current and XIP, modified PIN descriptions, power supply requirements and some reception sensitivity parameters.
8/10/2023	1.4	Changed pin15, pin16 IO ports; pulling down PA7 into download mode

Copyrights

It is prohibited to use or copy all or any part of contents in this manual without prior permission, especially applicable for trademarks, models, part numbers and figures.

Contact Us



Ms Zhou

Hangzhou BroadLink Technology Co., Ltd.

Add: Building C, 57 Jiang' er Road, Binjiang District, Hangzhou, P.R.China

Postcode: 310052

Tel: +86-571-85071744-8010

Email: bingqi.zhou@broadlink.com.cn

For more information of BroadLink Wi-Fi modules, please visit our website:

www.broadlink.com.cn

BroadLink