

# OPERATION MANUAL OF TPMS SENSOR

MODEL: TMSS6A3

Thank you for choosing our TPMS. This guide instructs the technician how to properly mount and dismount a Baolong Huf TPMS snap-in sensor.

## Introduction of TMSS6A3

TMSS6A3 is the transmitting module in TPMS. Its working frequency is 315MHz; Receiver Low frequency : 125KHz; supply:Battery;Radio frequency uses the FSK modulation and Manchester encoding mode;Antenna type:Monopole antenna,antenna Gain:-3.7dB~-3.4dB;cable loss : 3.12dB.The communication mode between WARDKS and receiving module is RF wireless communication. The module detects pressure and temperature inner the tire periodically and sends these information via RF output circuit to the receiving module. One can manually detect data inner tire by LF wake-up tools. Install it on the rim together with cycle valve.

## PART ONE MOUNTING AND DISMOUNTING OF TRANSMITTER

### 1. Mounting of Transmitter

#### 1.1 Identify Transmitter

Check whether the prepared sensor is the same with the image below.

Note: Only plastic or aluminum caps, aluminum valves and nickel plated valve cores can be used when replaced.

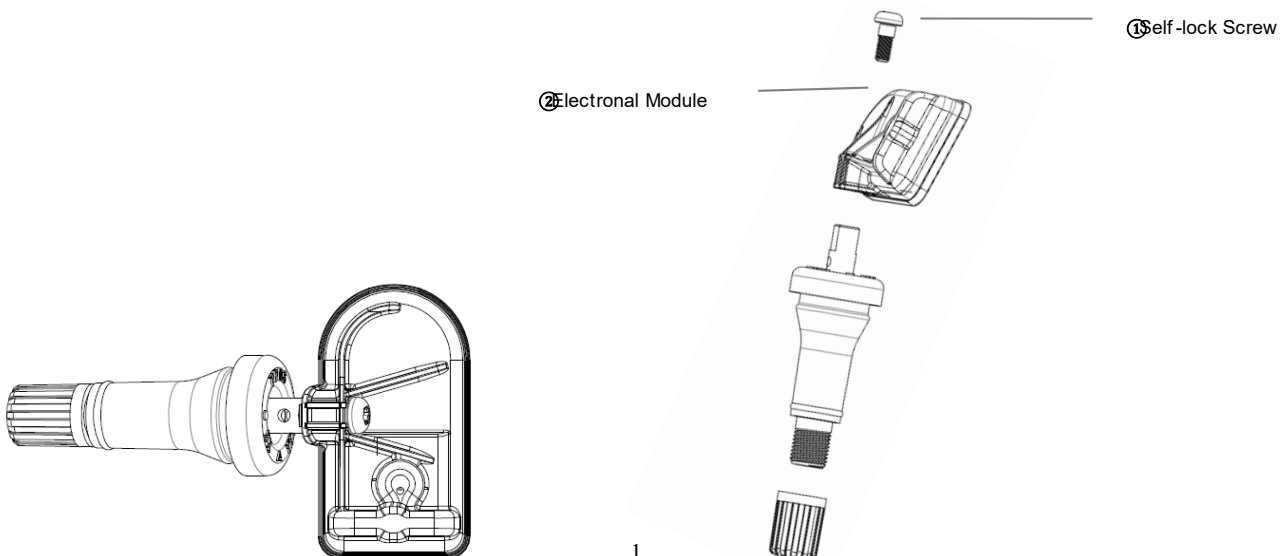

1.2 Before the transmitter is installed, the rim around the hole must be cleaned with a cloth.

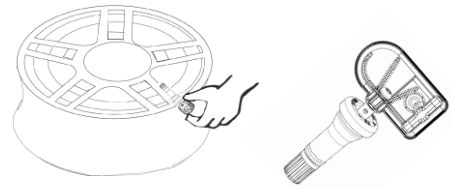

1.3 Remove the Self-lock Screw<sup>①</sup>, insert the valve stem through the rim hole from inside.

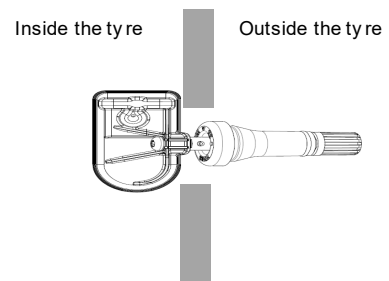

1.4 Place the Self-lock Screw<sup>①</sup> on the valve stem, and tighten with 5 Nm (44 inch pounds) torque.

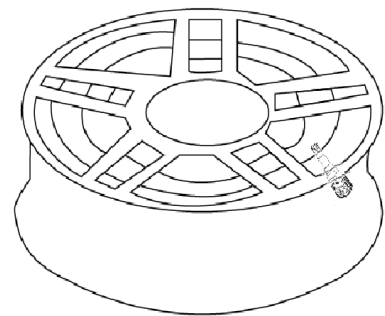

1.5 Lock the rim on the tyre changer. (If the mounting head of the tyre changer is positioned at 12 o'clock, then the valve should be at the 7 o'clock position.) Apply lubricant on both the tyre bead and rim. Mount the lower tyre bead on the rim. Ensure that the tyre bead does not touch the electronic module during mounting.

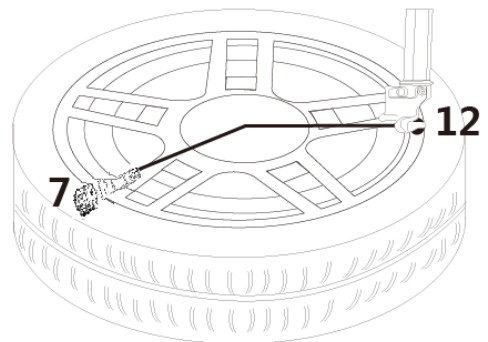

1.6 Mount the upper tyre bead the same way. (If the mounting head of the tyre changer is positioned at 12 o'clock, then the valve should be at the 5 o'clock position.) Inflate the tyre to nominal pressure.

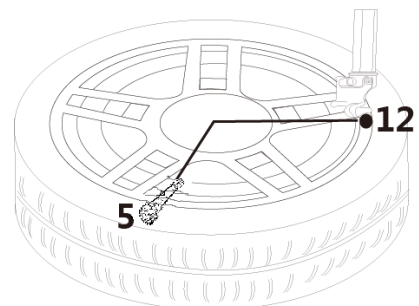

1.7 Apply soapsuds on the valve tip. If no leakage is



found, put on the valve cap<sup>®</sup>. If unsuccessful, try again.

1.8 Dynamically balance the wheel before it is placed back on the vehicle.



## 2. Dismounting of Transmitter

2.1 Deflate the tyre and remove the wheel weights from the rim. Push the tyre bead away from the rim. Make sure to always set the bead breaker at least 90 degrees from the valve stem to avoid damaging the electronic module.

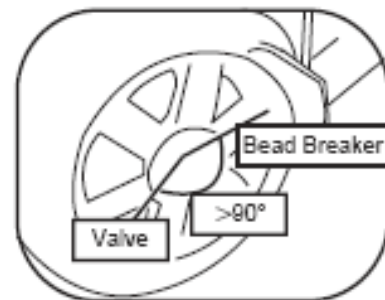

2.2 Firmly fix the wheel on the turntable clamps. (If the mounting head of the tyre changer is positioned at 12 o'clock, then the valve stem should be at the 11 o'clock position.) Apply lubricant to both tyre bead and rim, and then remove the upper tyre bead.

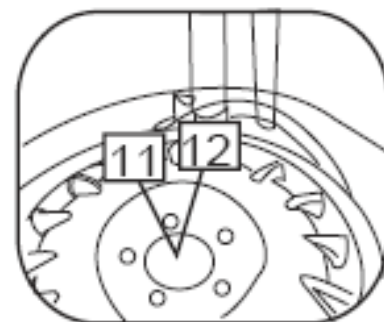

2.3 Use the same procedure to dismount the lower tyre bead. (If the mounting head of the tyre changer is at the 12 o'clock position, then the valve stem should also be at the 12 o'clock position.)

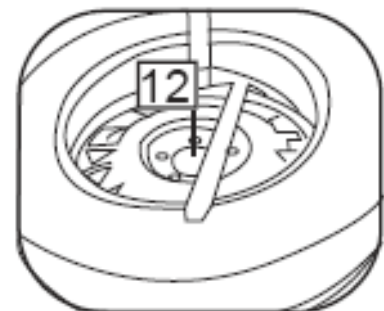

2.4 Final inspection: Visually inspect the rim, valve stem and electronic module to ensure no damage has occurred.

## **PART TWO FCC's Authentication Announcements**

Changes or modifications not expressly approved by the party responsible for compliance could void the user's authority to operate the equipment.

This device complies with Part 15 of the FCC Rules. Operation is subject to the following two conditions:

- (1) this device may not cause harmful interference, and
- (2) this device must accept any interference received, including interference that may cause undesired operation.

Note: This equipment has been tested and found to comply with the limits for a Class B digital device, pursuant to Part 15 of the FCC Rules. These limits are designed to provide reasonable protection against harmful interference in a residential installation. This equipment generates, uses, and can radiate radio frequency energy, and if not installed and used in accordance with the instructions, may cause harmful interference to radio communications. However, there is no guarantee that interference will not occur in a particular installation. If this equipment does cause harmful interference to radio or television reception, which can be determined by turning the equipment off and on, the user is encouraged to try to correct the interference by one or more of the following measures:

- Reorient or relocate the receiving antenna.
- Increase the separation between the equipment and receiver.
- Connect the equipment into an outlet on a circuit different from that to which the receiver is connected.
- Consult the dealer or an experienced radio/TV technician for help.

## **PART THREE IC's Authentication Announcements**

CAN ICES-3(B)/NMB-3(B)

## **PART FOUR WARRANTY**

This warranty covers substantial manufacturer's defects in workmanship and materials. It does not cover any unit that is damaged beyond normal use, not properly installed, subject to chemical contact, or other acts not sanctioned by the Owner's Manual.

All components are covered for one year following the date of purchase. If the warranty period specified in local law exceeds the period provided by Baolong Huf, the former will supersede the latter.

The warranty will be honored by any authorized Baolong Huf dealer. The owner is required to provide date of proof of purchase. The authorized dealer will determine if there is a warranty condition associated with materials and/or manufacturing workmanship. If a warranty condition exists, the component will be replaced free of charge and shipping

prepaid. The owner is responsible for any labor and installation charges.

The warranty does not include any further obligation whatsoever, including but not limited to actual installation of the replacement unit on the customer's vehicle.

All other Warranties, expressed or implied, are disclaimed. All collateral agreements, which purport to modify this limited warranty, are of no effect. The absolute limit of liability is the purchase price of the unit.

### **EU Conformity Statement**



This product and - if applicable - the supplied accessories too are marked with "CE" and comply therefore with the applicable harmonized European standards listed under the RED Directive 2014/53/EU, the RoHS Directive 2011/65/EU.

### **EU Conformity Statement**



This product is marked with "CE" and comply therefore with the applicable harmonized European standards listed under the Radio Equipment Directive 2014/53/EU.

### **RF Exposure Information**

This device has been tested and meets applicable limits for Radio Frequency (RF) exposure.



2012/19/EU (WEEE directive): Products marked with this symbol cannot be disposed of as unsorted municipal waste in the European Union. For proper recycling, return this product to your local supplier upon the purchase of equivalent new equipment, or dispose of it at designated collection points. For more information see: [www.recyclethis.info](http://www.recyclethis.info).

Please take attention that changes or modification not expressly approved by the party responsible for compliance could void the user's authority to operate the equipment.

This device complies with Industry Canada licence-exempt RSS standard(s). Operation is subject to the following two conditions:

- (1) this device may not cause interference, and
- (2) this device must accept any interference, including interference that may cause undesired operation of the device.

### **IC Statement**

This device complies with Industry Canada licence-exempt RSS standard(s). Operation is subject to the following two conditions:

- (1) this device may not cause interference, and
- (2) this device must accept any interference, including interference that may cause undesired operation of the device.

Le présent appareil est conforme aux CNR d'Industrie Canada applicables aux appareils radioexempts de licence. L'exploitation est autorisée aux deux conditions suivantes :

- (1) l'appareil ne doit pas produire de brouillage, et  
(2) l'utilisateur de l'appareil doit accepter tout brouillage radioélectrique subi, même si le brouillage est susceptible d'en compromettre le fonctionnement.

**Baolong Huf Shanghai Electronics Co.,Ltd. is not liable for any direct, consequential, indirect or punitive damages of any kind.**



Hereby, Baolong Huf Shanghai Electronics Co., Ltd. declares that the radio equipment type TMSS6A3 is in compliance with Directive 2014/53/EU.

The full text of the EU declaration of conformity is available at the following internet address:  
<https://www.intellisens.com/downloads>

Frequency band: 315 MHz

Maximum Transmit Power: < 10 mW

Manufacturer:

Baolong Huf Shanghai Electronics Co., Ltd., 1st Floor, Building 5, 5500 Shenzhuan Rd, Songjiang Shanghai, China

Importer:

Huf Baolong Electronics Bretten GmbH

Gewerbestraße 40

D-75015 Bretten

**NOTE:**Baolong Huf Shanghai Electronics Co.,Ltd. reserves the right to change the contents of this manual at any time without notice. The information contained in this manual is proprietary and must not be reproduced without prior written consent from Baolong Huf Shanghai Electronics Co.,Ltd.

<b>Company:</b> Baolong Huf Shanghai Electronics Co.,Ltd.
<b>Address:</b> 1st Floor,Building 5,5500 Shenzhuan Rd,Songjiang,Shanghai
<b>TEL:</b> +86-21-31273333
<b>Fax:</b> +86-21-31190319
<b>E-mail:</b> sbic@baolong.biz
<b>Web:</b> www.baolong.biz