

一、Plane structural diagram: Unit:MM

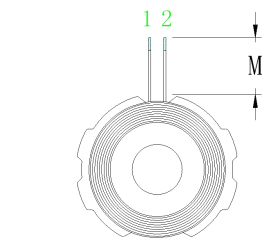
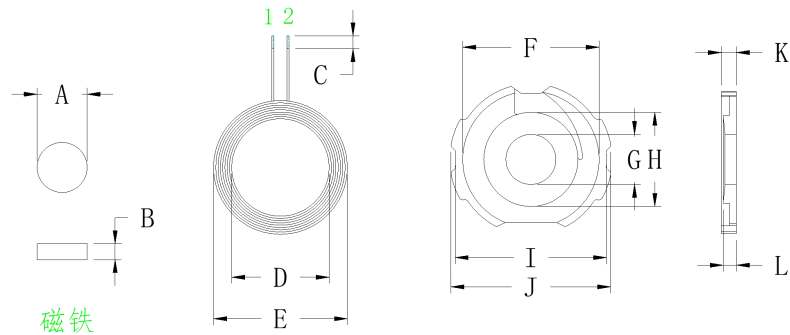

M/N:MPA2

| | |
|---|---------------------|
| A | 7.7 ± 0.05 |
| B | 2.0 ± 0.05 |
| C | 2 ± 1 |
| D | 14 ± 0.2 |
| E | 20.5 ± 0.5 |
| F | 21 ± 0.1 |
| G | 7.7 ± 0.05 |
| H | 13.5 ± 0.1 |
| I | 23.5 ± 0.2 |
| J | 25 ± 0.2 |
| K | 2.55 ± 0.1 |
| L | 2.25 ± 0.1 中柱高度 |
| M | 8 ± 1 |

二、Product specifications:

| Foot position | wire diameter | number of laps | Remark |
|---------------|---------------|----------------|-----------------------|
| 1 - 2 | 0.08*24P | 14 | Hot air twisting line |

Technical requirements:

1. Secure the ends of the wires to prevent loose or broken wires.
2. Trim excessive wire lengths and tinplate them according to customer specifications, with a uniform tinning depth of 2 ± 1 mm.
3. Apply appropriate white adhesive onto the soft magnetic sheet and attach the coil, ensuring a clean and tidy product surface throughout the process."
4. The soft magnetic sheet used is made with round holes and no damage
5. Additional process (according to customer requirements): Install 7.7x2.0mm magnet in the middle round hole of the finished product and put in the finished product

Add 14mm round double-sided adhesive to the back, and the rear packaging

四. Electrical activity parameters:

1. Intance value, Q value:PIN 1 — 2 = 8.1uH ±0.2UH, Q value ≥35

The above inductance value is Quanhua 1062A instrument, and 10KHZ/0.3Vrms is the standard or equivalent instrument. Q value is Quanhua 1062A instrument, 100KHZ/0.3Vrms as standard or equivalent instrument

五、material list :

| Number | Name | Material | Supplier | Remark |
|--------|----------------------------|---|-------------------------|---|
| 1 | Hot wind hanging line | 0.08X24P | Vihan or equivalent | |
| 2 | magnetic sheet | G25 Soft substrate | Tiantong or equivalent | |
| 3 | tin | High temperature environmental protection | Thousand Islands | |
| 4 | alban | BY882 | Bao month or equivalent | |
| 5 | Strong magnetic | 7.7*2(Strength is greater than 3000GS) | Liansheng or equivalent | Additional processes according to customer requirements |
| 6 | double faced adhesive tape | diameter 14mm | Hhuiteng or d | |
| | | | | |
| | | | | |
| | | | | |
| | | | | |



东莞市煜耀电子科技有限公司

DONGGUAN YUYAO ELECTRONIC TECHNOLOGY CO.,LTD

工厂地址：东莞市塘厦林村新阳路1号新太阳城工业城21栋

Dongguan City Tangxia Lin Village Xinyang Road No. 1 new Sun City Industrial City 21 building

TEL: 0769-82866410

FAX: 0769-82866409