

承认书

SPECIFICATION FOR APPROVAL

客户:

CUSTOMER: 深圳市分寸科技有限公司

客户料号:

CUST P/N:

产品型号: J-FCA11L10

DESC:

日期: 20220829

DATE:

版本:

VERSION: A.0

拟制 PREPARED BY	审核 CHECKED BY	批准 APPROVED BY	客户承认 CUSTOMER APPROVE
杨茂新	刘惜姜	罗杰	

东莞市吉欧电子科技有限公司

DONGGUAN JIOU ELECTRONIC TECHNOLOGY CO,LTD

公司地址: 东莞市石碣镇新发工业区

TEL:0769-83067050

E-mail: lybofmana@163.com

DONGGUAN JIOU ELECTRONIC TECHNOLOGY CO, LTD

东莞市吉欧电子科技有限公司

SPECIFICATION

产品型号 DESC	J-FCA11L10	版本 REV:A.O	客户 CUST	分寸
			客户料号 CUST P/N	

一、尺寸 DIMENSION(MM)

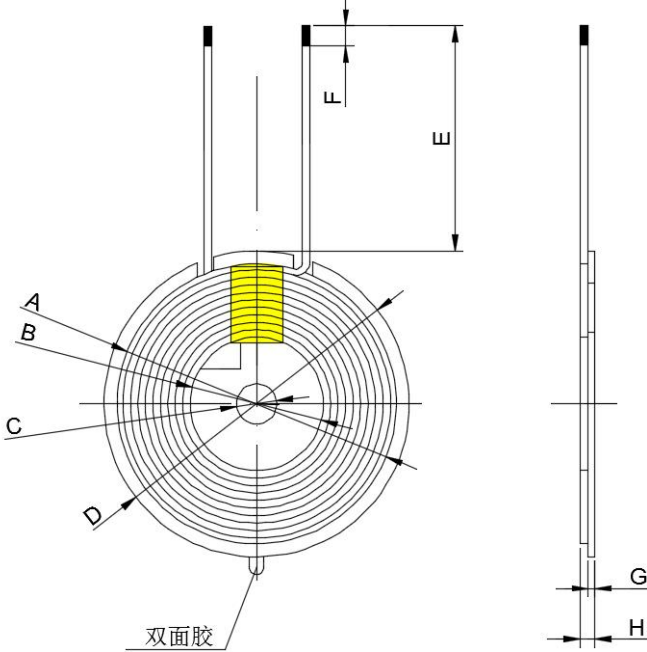
 <p>Coil gain: 0dBi</p>	A	43±1mm
	B	20.5±0.5 mm
	C	5±0.5 mm
	D	50±1mm
	E	10±2 mm
	F	3±2 mm
	G	1±0.1 mm
	H	3.0Max

二、绕线参数 Winding Specification:

线材 Wire	圈数 Turns	绕线方向 Winding Direction
丝包线 0.08*105P	10TS	反绕

三、电气特性 ELECTRICAL CHARACTERISTICS:

温度 TEMPERATURE:25±10℃,湿度 RELATIVE HUMIDITY :65±20%

项目 TIEM	标准 SPECIFICATION	测试条件 TEST FREQUENCY	测试仪器 TEST EQUIPMENTS
IND	6.4UH±10%	100 KHZ/1.0V	LCZ METER 1062B
DCR	55mΩ Max		LCZ METER 1062B
gain	0DB		

拟制 PREPARED BY	审核 CHECKED BY	日期 DATE
杨茂新	刘惜姜	20220829

