

 **备倍电科技(深圳)有限公司**
FAB-CHAIN SERVICE CO., LTD.

Approval P/N

YE. L. XXXQ64043801

Item Description

G43.8C magnetic coil, hot air wire 0.08 * 24 * 2 coil surface

and double-sided back tape on the front side

Coil size 40.5 * 1 total thickness 1.8 inductance 6.4UH

lead length 15 solder 2MM positive and negative 2 positive and

negative 5% 10 turns

Version

Supplier

Shengwei Technology
深圳市鸿日昇威科技

SUPPLIER P/N

Manufacturer

**Manufacturer
P/N**

Prepare	Approval	Check	
RD确认	核准	审核	

备倍电科技(深圳)有限公司.

FAB-CHAIN SERVICE CO., LTD

深圳市宝安区石岩应人石创见工业园A栋5楼

**5th Floor, Building A chuangJian Industrial Park, Yingrenshi, Shiyan, BaoAn,
Shenzhen, China**

TEL: +86 755-26409987 FAX: +86 755-26402325

SPECIFICATION FOR APPROVAL

1. MECHANICAL DIMENSION (UNIT:mm)

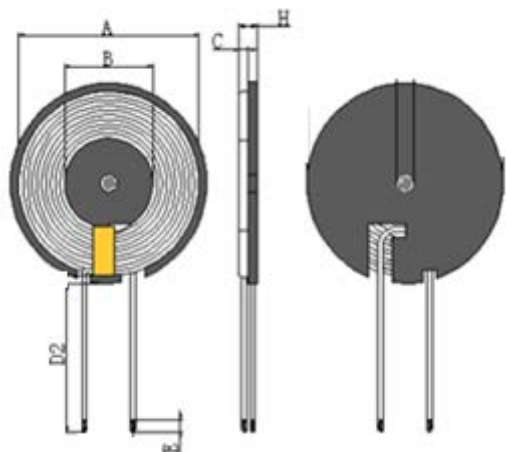

2. SCHEMATICS:

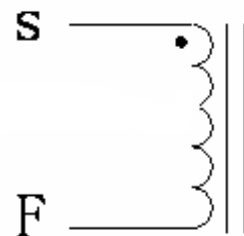

备注:1. 线圈面和背面 双面加胶

A	B	C	D2	E	H				I
43.5±0.5	20.5±0.5	0.8±0.05	15±3	3.5±2	1.8MAX				

3. WINDING:

STEP	START-FINISH	WIRE TYPE	TURNS	TAPE	REMARK
N1	S-F	丝包线 0.08*24*2P 2UEW	10TS (Ref)		

4. ELECTRICAL SPECIFICATION:

ITEM	L	DCR	Q值	温度	
TEST	线圈加磁片	S-F	S-F		
CON	100KHz, 0.25V	AT 25°C	100KHz, 0.25V	常温下	
SPEC	6.4uH±10%	68mΩ Max	76	0-85°C	

5. BILF OF MATERIAL:

NO.	ITEM	MATERIAL SPECIFICATION	MANUFACTURER	SGS NO.
1	丝包线0.08*24*2股	丙酮丝包线0.08*24*2股	NANJINGJINNINGCO,LTD	
2	无铅锡条	无铅锡条	QIAODO	
3	磁片	44*0.8锰锌硬磁片开L槽	TAIYI CO.,LTD	
4	胶水	黄胶9999	LIANCHENG CO.,LTD	
5	高温胶纸	8mm宽高温胶纸	CUDAK CO.,LTD	
6	背胶	41.5*0.1	CUDAK CO.,LTD	

HRSW ELECTRONICS CO.,LTD	PART NO	
	TITLE	G43.5开槽+线圈面和背面 双面背胶 15长
DRAWN BY	CHECKED BY	APPROVED BY
何伟华	韦立红	韦立红