



FCC TEST REPORT

FCC ID: 2ATCA-JREMWC

Report Number : ZKT-230406L2398E

Date of Test : April 03, 2023 to April 20, 2023

Date of issue : April 20, 2023

Total number of pages : 22

Test Result : PASS

Testing Laboratory : Shenzhen ZKT Technology Co., Ltd.

Address : 1/F, No. 101, Building B, No. 6, Tangwei Community Industrial Avenue, Fuhai Street, Bao'an District, Shenzhen, China

Applicant's name : ALOGIC Corporation Pty Ltd.

Address : Level 40, 140 Williams Street, Melbourne, VIC 3000, Australia

Manufacturer's name : ALOGIC Corporation Pty Ltd.

Address : Level 40, 140 Williams Street, Melbourne, VIC 3000, Australia

Test specification:

Standard : FCC CFR Title 47 Part 15 Subpart C

Test procedure : /

Non-standard test method : N/A

Test Report Form No. : TRF-EL-107_V0

Test Report Form(s) Originator..... : ZKT Testing

Master TRF : Dated: 2020-01-06

This device described above has been tested by ZKT, and the test results show that the equipment under test (EUT) is in compliance with the FCC requirements. And it is applicable only to the tested sample identified in the report.

This report shall not be reproduced except in full, without the written approval of ZKT, this document may be altered or revised by ZKT, personal only, and shall be noted in the revision of the document.

Product name : Magnetic Wireless Car Charger

Trademark : JOUNREY, JR-NY

Model/Type reference : JREMWCVM

Ratings : Input: DC 5V/2A, 9V/2A, 12V/1.5A by USB

Wireless Output: 15W(Max)



Testing procedure and testing location:

Testing Laboratory.....: **Shenzhen ZKT Technology Co., Ltd.**

Address.....: 1/F, No. 101, Building B, No. 6, Tangwei Community Industrial Avenue, Fuhai Street, Bao'an District, Shenzhen, China

Tested by (name + signature).....: Jim Liu

Reviewer (name + signature).....: Jackson Fang

Approved (name + signature).....: Lake Xie





TABLE OF CONTENTS

1. VERSION	4
2. TEST SUMMARY	5
2.1 TEST FACILITY	6
2.2 MEASUREMENT UNCERTAINTY	6
3. GENERAL INFORMATION	7
3.1 GENERAL DESCRIPTION OF EUT	7
3.2 Test mode	7
3.3 Block Diagram of EUT Configuration	7
3.4 Test Conditions	7
3.5 Description Of Support Units (Conducted Mode)	8
3.6 EQUIPMENTS LIST FOR ALL TEST ITEMS	9
4. CONDUCTED EMISSION TEST	9
4.1 CONDUCTED EMISSION MEASUREMENT	9
4.1.1 POWER LINE CONDUCTED EMISSION Limits	10
4.1.2 TEST PROCEDURE	10
4.1.3 DEVIATION FROM TEST STANDARD	10
4.1.4 TEST SETUP	11
4.1.5 EUT OPERATING CONDITIONS	11
4.1.6 Test Result	11
5. RADIATED EMISSION MEASUREMENT	14
5.1 Radiated Emission Limits	14
5.2 Anechoic Chamber Test Setup Diagram	15
5.3 Test Procedure	15
5.4 DEVIATION FROM TEST STANDARD	16
5.5 Test Result	16
6. BANDWIDTH TEST	19
7. ANTENNA REQUIREMENT	21
8. TEST SETUP PHOTO	22
9. EUT CONSTRUCTIONAL DETAILS	22



1. VERSION

Report No.	Version	Description	Approved
ZKT-230406L2398E	Rev.01	Initial issue of report	April 20, 2023



2. TEST SUMMARY

Test Item	Section in CFR 47	Result
Antenna requirement	15.203	Pass
AC Power Line Conducted Emission	15.207	Pass
Spurious Emission	15.209(a)(f)	Pass
20dB Bandwidth	15.215	Pass

NOTE:

(1) "N/A" denotes test is not applicable in this Test Report



2.1 TEST FACILITY

Shenzhen ZKT Technology Co., Ltd.
Add : 1/F, No. 101, Building B, No. 6, Tangwei Community Industrial Avenue, Fuhai Street,
Bao'an District, Shenzhen, China

FCC Test Firm Registration Number: 692225
Designation Number: CN1299
IC Registered No.: 27033

2.2 MEASUREMENT UNCERTAINTY

The reported uncertainty of measurement $y \pm U$, where expanded uncertainty U is based on a standard uncertainty multiplied by a coverage factor of $k=2$, providing a level of confidence of approximately 95 %.

No.	Item	Uncertainty
1	3m chamber Radiated spurious emission(9KHz-30MHz)	U=4.5dB
2	3m chamber Radiated spurious emission(30MHz-1GHz)	U=4.8dB
3	3m chamber Radiated spurious emission(1GHz-18GHz)	U=4.9dB
4	3m chamber Radiated spurious emission(18GHz-40GHz)	U=5.0dB
5	Conducted Adjacent channel power	U=1.38dB
6	Conducted output power uncertainty Above 1G	U=1.576dB
7	Conducted output power uncertainty below 1G	U=1.28dB
8	humidity uncertainty	U=5.3%
9	Temperature uncertainty	U=0.59℃



3. GENERAL INFORMATION

3.1 GENERAL DESCRIPTION OF EUT

Product Name:	Magnetic Wireless Car Charger
Model No.:	JREMWCVM
Model Difference:	N/A
Serial No.:	N/A
Hardware version:	V1.0
Software version:	V1.0
Operation Frequency:	110-205KHz
Modulation type:	MSK
Antenna Type:	Coil Antenna
Antenna gain:	0dBi
Power supply:	Input: DC 5V/2A, 9V/2A, 12V/1.5A by USB Wireless Output: 15W(Max)
Test description:	Mobile Phone Battery >98%, =50% and <1% are tested, and the worst is <1%.

3.2 Test mode

Test Modes:		
Mode 1	EUT + Mobile Phone (15W)	Record
Note: All test modes were pre-tested, but we only recorded the worst case in this report.		

3.3 Block Diagram of EUT Configuration

Conducted Emission

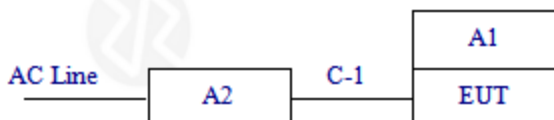

Radiated Emission

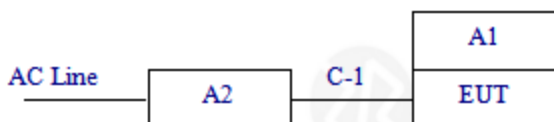

3.4 Test Conditions

Temperature: 23~26°C

Relative Humidity: 54~63 %



3.5 Description Of Support Units (Conducted Mode)

The EUT has been tested as an independent unit together with other necessary accessories or support units. The following support units or accessories were used to form a representative test configuration during the tests.

Item	Equipment	Mfr/Brand	Model/TypeNo.	Series No.	Note
E1	Magnetic Wireless Car Charger	JOUNREY, JR-NY	JREMWCVM	N/A	EUT
A1	Mobile Phone	Huawei	TEL-ANOOa	N/A	Auxiliary
A2	Adapter	UGREEN	CD226	N/A	Auxiliary

Item	Shielded Type	Ferrite Core	Length	Note
C-1	Unshielded	Without Ferrite	1m	USBA to C Cable

Note:

- (1) The support equipment was authorized by Declaration of Confirmation.
- (2) For detachable type I/O cable should be specified the length in cm in 『Length』 column.
- (3) "YES" is means "shielded" "with core"; "NO" is means "unshielded" "without core".



3.6 EQUIPMENTS LIST FOR ALL TEST ITEMS

Radiation Test equipment

Item	Kind of Equipment	Manufacturer	Type No.	Serial No.	Last calibration	Calibrated until
1	Bilog Antenna	Schwarzbeck	VULB9168	N/A	Oct. 17, 2022	Oct. 16, 2023
2	Loop Antenna	TESEQ	HLA6121	58357	Oct. 17, 2022	Oct. 16, 2023
3	Test Cable	N/A	R-01	N/A	Oct. 18, 2022	Oct. 17, 2023
4	Test Cable	N/A	R-02	N/A	Oct. 18, 2022	Oct. 17, 2023
5	EMI Test Receiver (9kHz-7GHz)	R&S	ESCI7	101169	Oct. 18, 2022	Oct. 17, 2023
6	Antenna Mast	EM	SC100_1	N/A	N/A	N/A
7	Turn Table	EM	SC100	N/A	N/A	N/A
8	Spectrum Analyzer	KEYSIGHT	9020A	MY5537083 5	Oct. 18, 2022	Oct. 17, 2023
9	Amplifier (30-1000MHz)	EM Electronics	EM330 Amplifier	060747	Oct. 18, 2022	Oct. 17, 2023
10	D.C. Power Supply	LongWei	TPR-6405D	N/A	\	\
11	EMC Software	Frad	EZ-EMC	Ver.EMC- CON 3A1.1	\	\
12	Turntable	MF	MF-7802BS	N/A	\	\
13	Antenna tower	MF	MF-7802BS	N/A	\	\

Conduction Test equipment

Item	Kind of Equipment	Manufacturer	Type No.	Serial No.	Last calibration	Calibrated until
1	LISN	R&S	ENV216	101471	Oct. 22, 2022	Oct. 21, 2023
2	LISN	CYBERTEK	EM5040A	E185040014 9	Oct. 22, 2022	Oct. 21, 2023
3	Test Cable	N/A	C01	N/A	Oct. 18, 2022	Oct. 17, 2023
4	Test Cable	N/A	C02	N/A	Oct. 18, 2022	Oct. 17, 2023
5	EMI Test Receiver	R&S	ESCI3	101393	Oct. 17, 2022	Oct. 16, 2023
6	EMC Software	Frad	EZ-EMC	Ver.EMC- CON 3A1.1	\	\

4. CONDUCTED EMISSION TEST

4.1 CONDUCTED EMISSION MEASUREMENT

Test Requirement:	FCC Part15 C Section 15.207
Test Method:	ANSI C63.10:2013
Test Frequency Range:	150KHz to 30MHz
Receiver setup:	RBW=9KHz, VBW=30KHz, Sweep time=auto



4.1.1 POWER LINE CONDUCTED EMISSION Limits

FREQUENCY (MHz)	Limit (dBuV)		Standard
	Quas-peak	Average	
0.15 -0.5	66 - 56 *	56 - 46 *	FCC
0.50 -5.0	56.00	46.00	FCC
5.0 -30.0	60.00	50.00	FCC

Note:

(1) *Decreases with the logarithm of the frequency.

4.1.2 TEST PROCEDURE

- The EUT was placed 0.8 meters from the horizontal ground plane with EUT being connected to the power mains through a line impedance stabilization network (LISN). All other support equipments powered from additional LISN(s). The LISN provide 50 Ohm/ 50uH of coupling impedance for the measuring instrument.
- Interconnecting cables that hang closer than 40 cm to the ground plane shall be folded back and forth in the center forming a bundle 30 to 40 cm long.
- I/O cables that are not connected to a peripheral shall be bundled in the center. The end of the cable may be terminated, if required, using the correct terminating impedance. The overall length shall not exceed 1 m.
- LISN at least 80 cm from nearest part of EUT chassis.
- For the actual test configuration, please refer to the related Item –EUT Test Photos.

4.1.3 DEVIATION FROM TEST STANDARD

No deviation



4.1.4 TEST SETUP

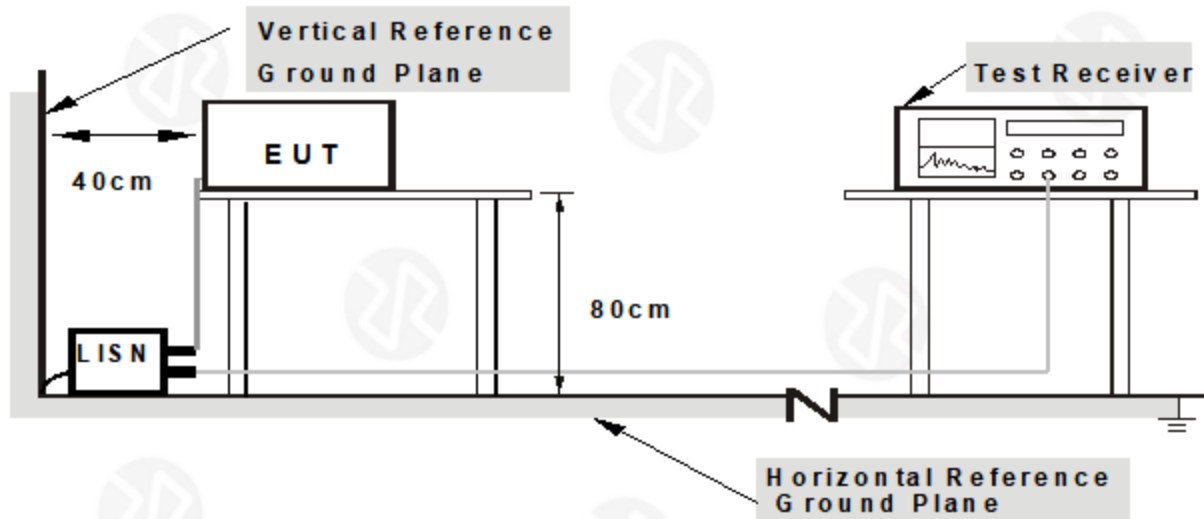

- Note: 1. Support units were connected to second LISN.**
2. Both of LISNs (AMN) are 80 cm from EUT and at least 80 cm from other units and other metal planes

4.1.5 EUT OPERATING CONDITIONS

The EUT was configured for testing in a typical fashion (as a customer would normally use it). The EUT has been programmed to continuously transmit during test. This operating condition was tested and used to collect the included data.

We pretest AC 120V and AC 230V, the worst voltage was AC 120V and the data recording in the report.

4.1.6 Test Result



Temperature :	26°C	Relative Humidity:	54%
Pressure :	101kPa	Phase :	L
Test Voltage :	AC 120V/60Hz		



No.	Frequency (MHz)	Reading (dBuV)	Factor (dB)	Level (dBuV)	Limit (dBuV)	Margin (dB)	Detector	P/F	Remark
1	1.7700	35.84	10.08	45.92	56.00	-10.08	QP	P	
2	1.7700	34.32	10.08	44.40	46.00	-1.60	AVG	P	
3	2.0670	34.93	10.08	45.01	56.00	-10.99	QP	P	
4	2.0670	34.18	10.08	44.26	46.00	-1.74	AVG	P	
5	2.3594	35.32	10.08	45.40	56.00	-10.60	QP	P	
6 *	2.3594	34.87	10.08	44.95	46.00	-1.05	AVG	P	
7	2.9490	35.32	10.10	45.42	56.00	-10.58	QP	P	
8	2.9490	34.67	10.10	44.77	46.00	-1.23	AVG	P	
9	1.1805	35.08	10.07	45.15	56.00	-10.85	QP	P	
10	1.1805	33.91	10.07	43.98	46.00	-2.02	AVG	P	
11	1.4775	35.60	10.07	45.67	56.00	-10.33	QP	P	
12	1.4775	33.88	10.07	43.95	46.00	-2.05	AVG	P	

Notes:

1. An initial pre-scan was performed on the line and neutral lines with peak detector.
2. Quasi-Peak and Average measurement were performed at the frequencies with maximized peak emission.
3. Measurement Level = Reading level + Correct Factor



Temperature :	26°C	Relative Humidity:	54%
Pressure :	101kPa	Phase :	N
Test Voltage :	AC 120V/60Hz		

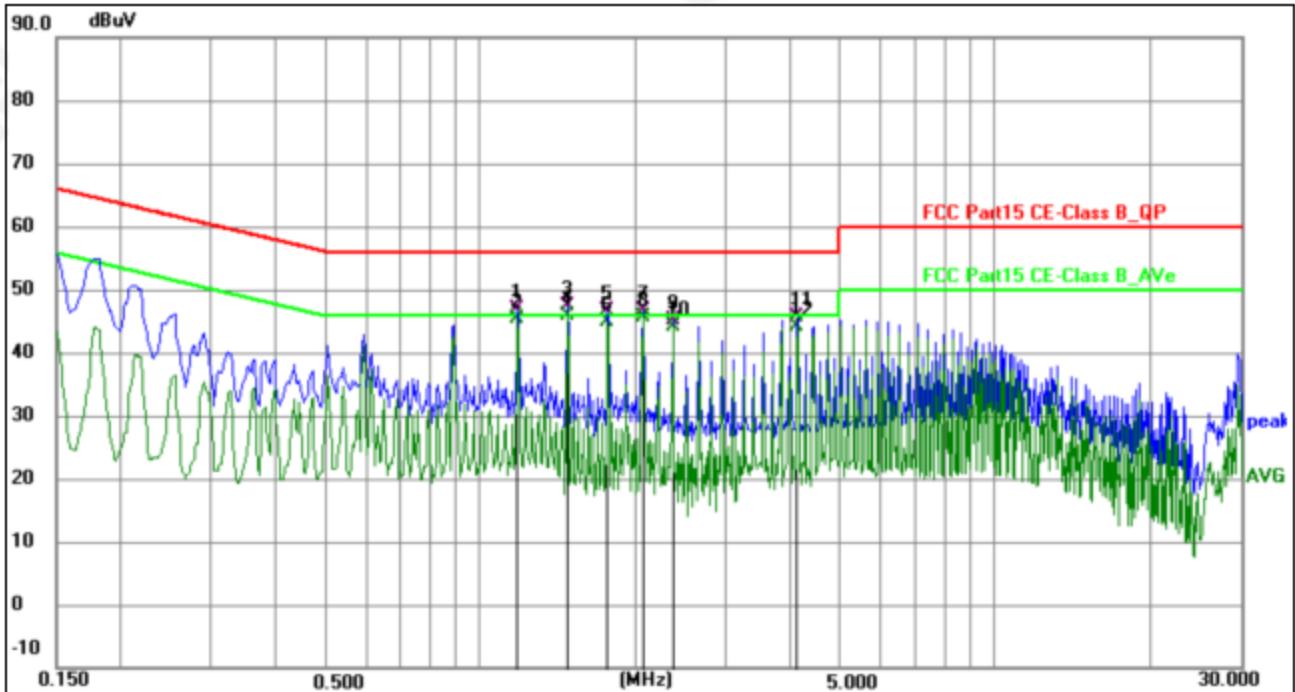

No.	Frequency (MHz)	Reading (dBuV)	Factor (dB)	Level (dBuV)	Limit (dBuV)	Margin (dB)	Detector	P/F	Remark
1	1.1805	36.90	10.03	46.93	56.00	-9.07	QP	P	
2	1.1805	35.43	10.03	45.46	46.00	-0.54	AVG	P	
3	1.4775	37.21	10.07	47.28	56.00	-8.72	QP	P	
4 *	1.4775	35.82	10.07	45.89	46.00	-0.11	AVG	P	
5	1.7700	36.52	10.07	46.59	56.00	-9.41	QP	P	
6	1.7700	34.87	10.07	44.94	46.00	-1.06	AVG	P	
7	2.0670	36.53	10.07	46.60	56.00	-9.40	QP	P	
8	2.0670	35.63	10.07	45.70	46.00	-0.30	AVG	P	
9	2.3640	35.03	10.07	45.10	56.00	-10.90	QP	P	
10	2.3640	34.10	10.07	44.17	46.00	-1.83	AVG	P	
11	4.1369	35.40	10.11	45.51	56.00	-10.49	QP	P	
12	4.1369	34.07	10.11	44.18	46.00	-1.82	AVG	P	

Notes:

1. An initial pre-scan was performed on the line and neutral lines with peak detector.
2. Quasi-Peak and Average measurement were performed at the frequencies with maximized peak emission.
3. Measurement Level = Reading level + Correct Factor



5. RADIATED EMISSION MEASUREMENT

Test Requirement:	FCC Part15 C Section 15.209				
Test Method:	ANSI C63.10:2013				
Test Frequency Range:	9kHz to 1GHz				
Test site:	Measurement Distance: 3m				
Receiver setup:	Frequency	Detector	RBW	VBW	Value
	9KHz-150KHz	Quasi-peak	200Hz	600Hz	Quasi-peak
	150KHz-30MHz	Quasi-peak	9KHz	30KHz	Quasi-peak
	30MHz-1GHz	Quasi-peak	120KHz	300KHz	Quasi-peak
	Above 1GHz	Peak	1MHz	3MHz	Peak
Peak		1MHz	10Hz	Average	

5.1 Radiated Emission Limits

Limits for frequency below 30MHz

Frequency	Limit (uV/m)	Measurement Distance(m)	Remark
0.009-0.490	2400/F(kHz)	300	Quasi-peak Value
0.490-1.705	24000/F(kHz)	30	Quasi-peak Value
1.705-30	30	30	Quasi-peak Value

Limits for frequency Above 30MHz

Frequency	Limit (dBuV/m @3m)	Remark
30MHz-88MHz	40.00	Quasi-peak Value
88MHz-216MHz	43.50	Quasi-peak Value
216MHz-960MHz	46.00	Quasi-peak Value
960MHz-1GHz	54.00	Quasi-peak Value
Above 1GHz	54.00	Average Value
	74.00	Peak Value



5.2 Anechoic Chamber Test Setup Diagram

(A) Radiated Emission Test-Up Frequency Below 30MHz

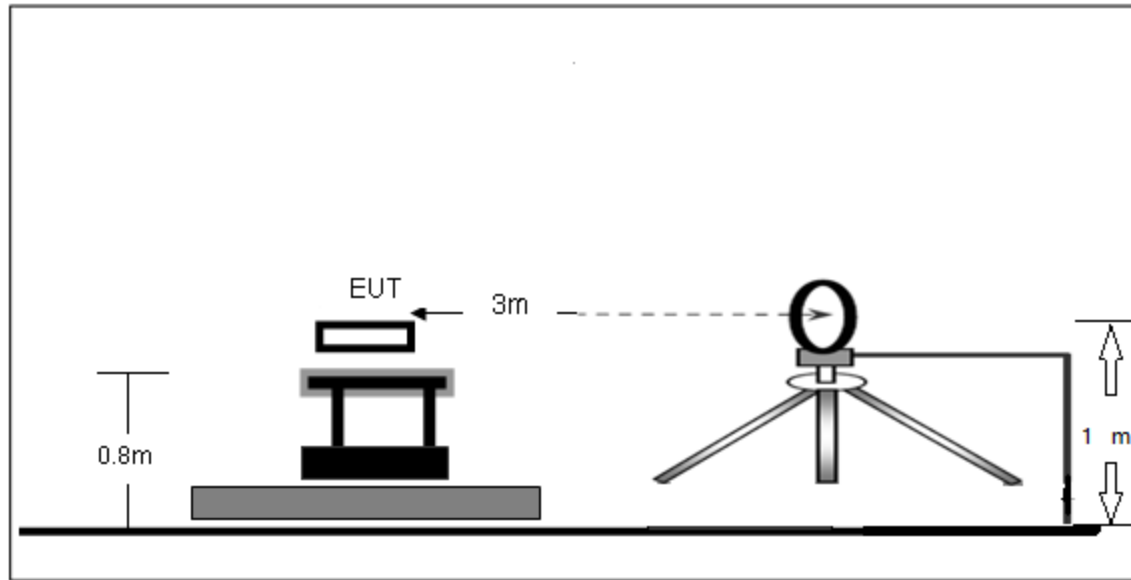

(B) Radiated Emission Test-Up Frequency 30MHz~1GHz

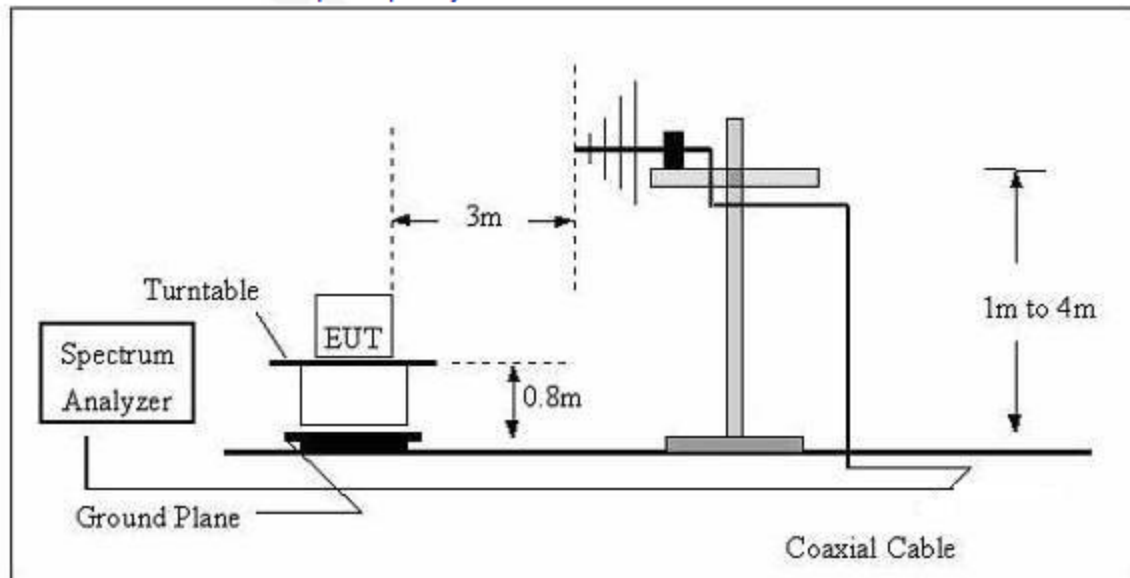

The radiated emission tests were performed in the 3 meters chamber test site, using the setup accordance with the ANSI C63.10-2013. The specification used was the FCC 15.209 and FCC 15.205 limits.

5.3 Test Procedure

The EUT is placed on a turn table which is 0.8 meter above ground. The turn table can rotate 360 degrees to determine the position of the maximum emission level. The EUT is set 3 meters away from the receiving antenna which is mounted on a antenna tower. The antenna can move up and down between 1 to 4 meters to find out the maximum emission level. Broadband antenna (calibrated by dipole antenna) are used as a receiving antenna. Both horizontal and vertical polarization of the antenna are set on measurement.



5.4 DEVIATION FROM TEST STANDARD

No deviation

5.5 Test Result

Measurement data:

Note: Limit dBuV/m @3m = Limit dBuV/m @300m+ 80
Limit dBuV/m @3m = Limit dBuV/m @30m + 40

9 kHz~30 MHz

Temperature:	26℃	Relative Humidity:	54%
Pressure:	101 kPa	Polarization:	coaxial
Test Voltage:	AC 120V/60Hz		

Frequency (kHz)	Meter Reading (dBμV)	Factor (dB)	Emission Level (dBμV/m)	Limits (dBμV/m)	Margin (dB)	Detector Type
15.80	16.08	31.4	47.48	123.63	-76.15	QP
82.10	19.84	26.26	46.10	109.32	-63.22	QP
125.00	14.99	25.8	40.79	105.67	-64.88	QP
148.10	36.42	25.61	62.03	104.19	-42.16	QP
442.00	26.63	25.25	51.88	94.70	-42.82	QP
1289.00	24.00	25.18	49.18	65.40	-16.22	QP

Temperature:	26℃	Relative Humidity:	54%
Pressure:	101 kPa	Polarization:	coplaner
Test Voltage:	AC 120V/60Hz		

Frequency (kHz)	Meter Reading (dBμV)	Factor (dB)	Emission Level (dBμV/m)	Limits (dBμV/m)	Margin (dB)	Detector Type
82.10	21.23	26.26	47.49	109.32	-61.83	QP
125.00	16.18	25.8	41.98	105.67	-63.69	QP
148.20	50.73	25.61	76.34	104.19	-27.85	QP
442.00	37.15	25.25	62.40	94.70	-32.30	QP
739.00	25.71	25.07	50.78	70.23	-19.45	QP
1032.00	26.26	25.22	51.48	67.33	-15.85	QP

Note:

Pre-scan in the all of mode, the worst case in of was recorded.

Factor = antenna factor + cable loss – pre-amplifier.

Margin = Emission Level- Limit.



30MHz-1GHz

Temperature:	26°C	Relative Humidity:	54%
Pressure:	101 kPa	Polarization:	Horizontal
Test Voltage:	AC 120V/60Hz		

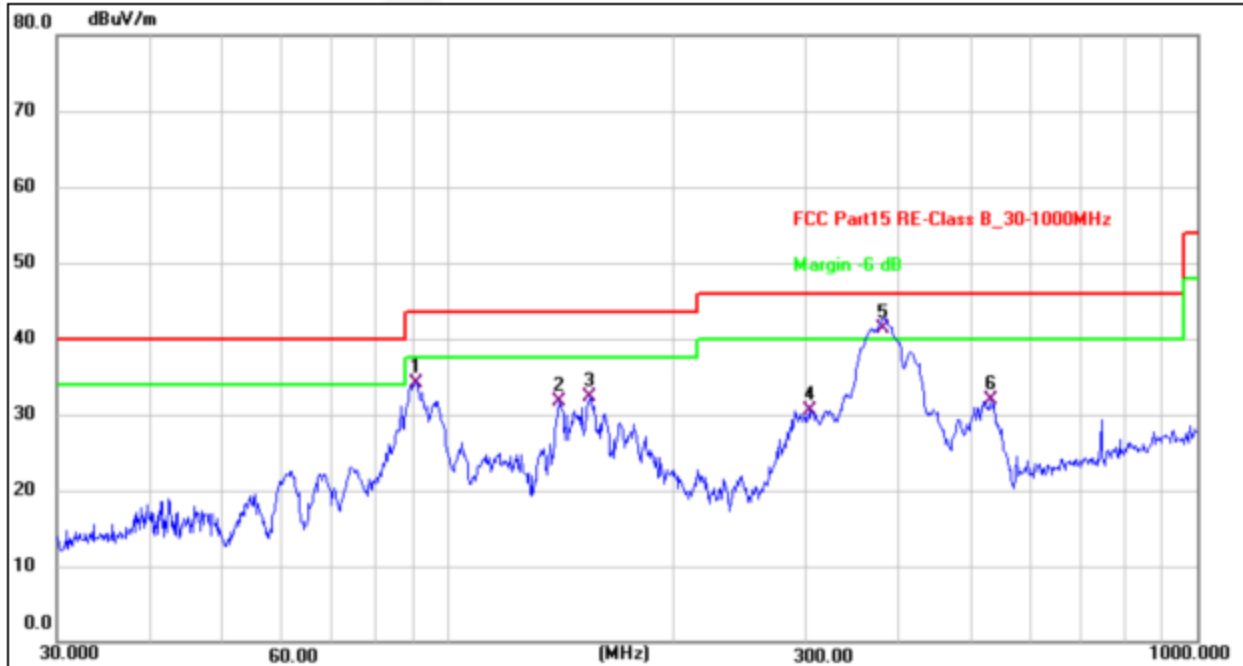

No.	Frequency (MHz)	Reading (dBuV)	Factor (dB/m)	Level (dBuV/m)	Limit (dBuV/m)	Margin (dB)	Detector	Height (cm)	Azimuth (deg.)	P/F	Remark
1	90.5374	47.68	-13.53	34.15	43.50	-9.35	QP	200	155	P	
2	140.3421	41.21	-9.49	31.72	43.50	-11.78	QP	200	95	P	
3	154.8204	41.35	-9.05	32.30	43.50	-11.20	QP	200	65	P	
4	304.6099	39.01	-8.42	30.59	46.00	-15.41	QP	100	263	P	
5 *	381.1791	47.98	-6.74	41.24	46.00	-4.76	QP	100	112	P	
6	530.1014	35.23	-3.31	31.92	46.00	-14.08	QP	200	318	P	



Temperature:	26℃	Relative Humidity:	54%
Pressure:	101kPa	Polarization:	Vertical
Test Voltage:	AC 120V/60Hz		

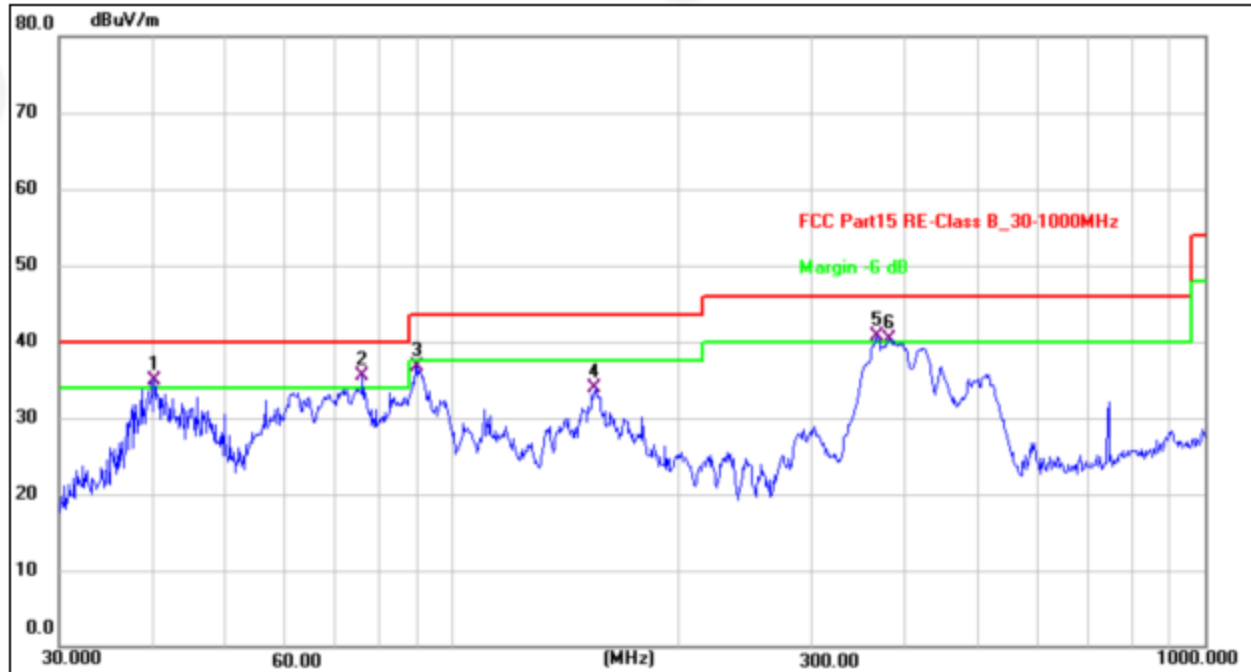

No.	Frequency (MHz)	Reading (dBuV)	Factor (dB/m)	Level (dBuV/m)	Limit (dBuV/m)	Margin (dB)	Detector	Height (cm)	Azimuth (deg.)	P/F	Remark
1 !	40.1347	43.24	-8.27	34.97	40.00	-5.03	QP	100	92	P	
2 *	75.9773	48.03	-12.52	35.51	40.00	-4.49	QP	100	11	P	
3	89.9046	50.22	-13.57	36.65	43.50	-6.85	QP	100	253	P	
4	154.8204	42.97	-9.05	33.92	43.50	-9.58	QP	100	102	P	
5 !	366.8231	47.83	-7.22	40.61	46.00	-5.39	QP	100	314	P	
6 !	381.2485	47.12	-6.74	40.38	46.00	-5.62	QP	100	334	P	

Remarks:

- 1.Final Level =Receiver Read level + Antenna Factor + Cable Loss – Preamplifier Factor
- 2.The emission levels of other frequencies are very lower than the limit and not show in test report.



6. BANDWIDTH TEST

1. Set RBW = 1Hz.
2. Set the video bandwidth (VBW) $\geq 3 \times$ RBW.
3. Detector = Peak.
4. Trace mode = max hold.
5. Sweep = auto couple.
6. Allow the trace to stabilize.
7. Measure the maximum width of the emission that is constrained by the frequencies associated with the two outermost amplitude points (upper and lower frequencies) that are attenuated by 20 dB relative to the maximum level measured in the fundamental emission.

TEST SETUP

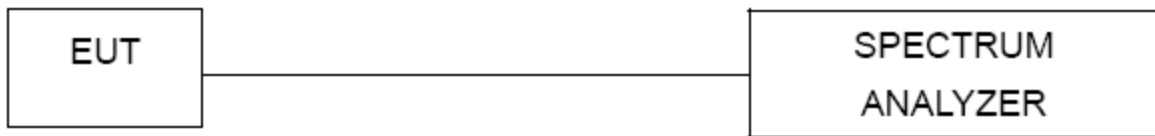



Temperature :	26 °C	Relative Humidity:	54%
Pressure :	101kPa		

Frequency (KHz)	20dB bandwidth (Hz)	99% bandwidth (Hz)	Result
147.6	49	45	Pass

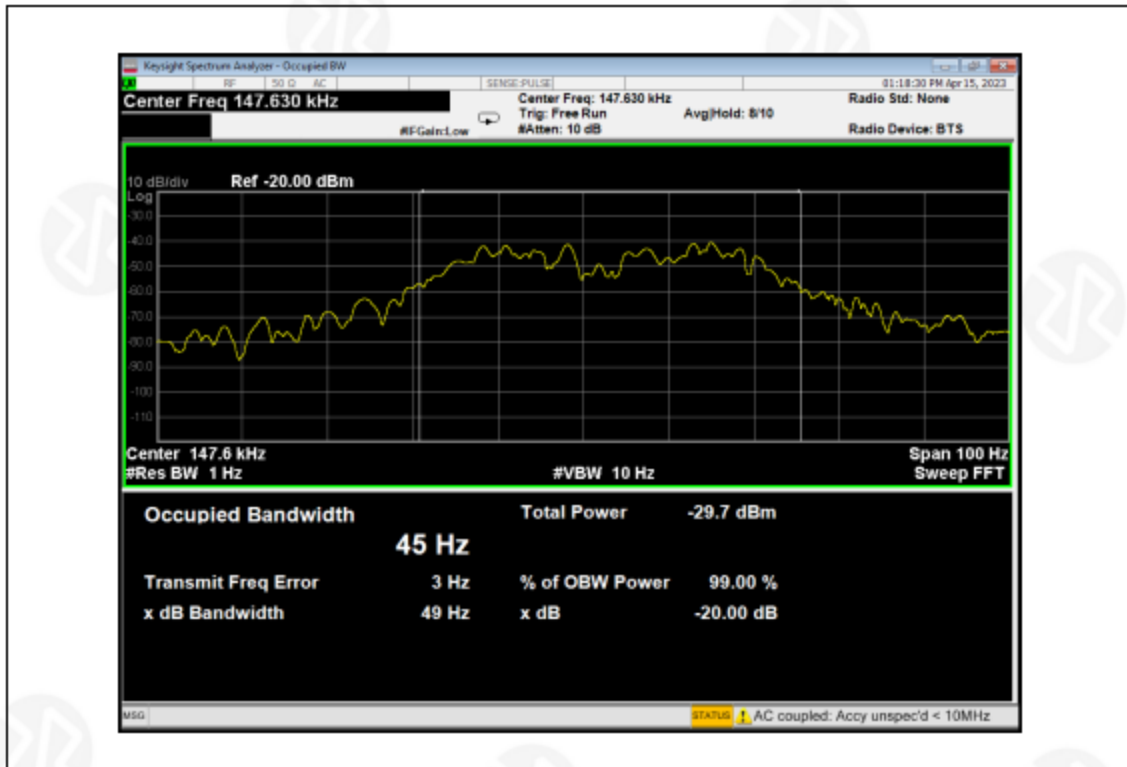



7. ANTENNA REQUIREMENT

Standard requirement:	FCC Part15 C Section 15.203
15.203 requirement: An intentional radiator shall be designed to ensure that no antenna other than that furnished by the responsible party shall be used with the device. The use of a permanently attached antenna or of an antenna that uses a unique coupling to the intentional radiator, the manufacturer may design the unit so that a broken antenna can be replaced by the user, but the use of a standard antenna jack or electrical connector is prohibited.	
EUT Antenna:	
The antenna is Coil antenna, the best case gain of the antennas is 0dBi, reference to the Internal Photos for details	



8. TEST SETUP PHOTO

Reference to the Test Setup Photos for details.

9. EUT CONSTRUCTIONAL DETAILS

Reference to the External Photos and Internal Photos for details.

******* END OF REPORT *******