

承认书

SPECIFICATION FOR APPROVAL

客户:

CUSTOMER: 深圳市冲向未来科技有限公司

客户料号:

CUST P/N:

产品型号: J-FCTM19-L190

DESC:

日期: 20220829

DATE:

版本:

VERSION: A.0

拟制 PREPARED BY	审核 CHECKED BY	批准 APPROVED BY	客户承认 CUSTOMER APPROVE
杨茂新	刘惜姜	罗杰	

东莞市吉欧电子科技有限公司

DONGGUAN JIOU ELECTRONIC TECHNOLOGY CO,LTD

公司地址: 东莞市石碣镇新发工业区

TEL:0769-83067050

E-mail: lybofmana@163.com

版本变更履历

Version Change History

版本 Rev	变更前 Before Change	变更后 After Change	更改日期 Change Date	批准 Approved BY
A.0	新发行		20220829	罗杰

SPECIFICATION

产品型号 DESC	J-FCTM19-L190	版本 REV:A.O	客户 CUST	
			客户料号 CUST P/N	

一、 尺寸 DIMENSION(MM)

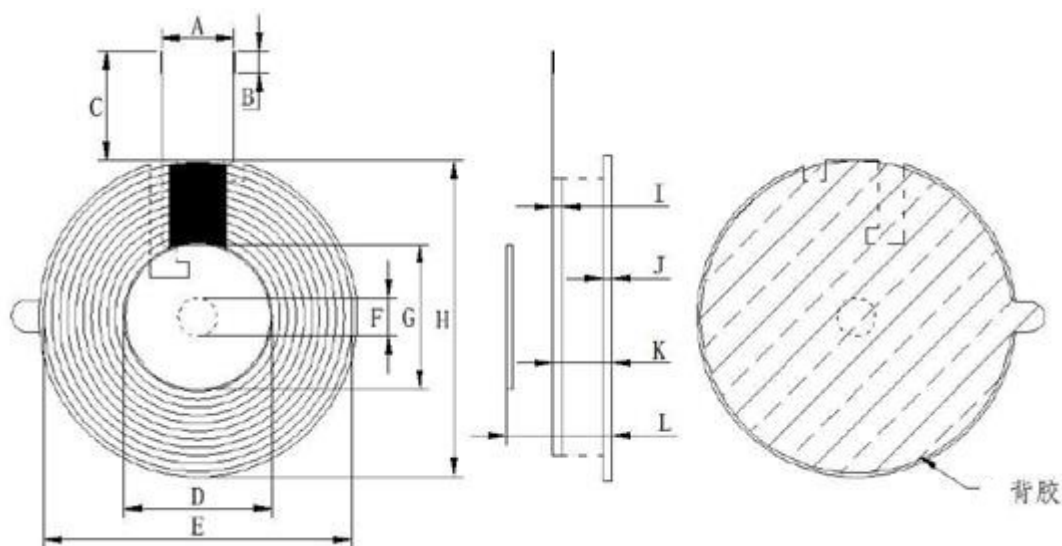

A	B	C	D	E	F	G
10±2 REF	3±1.5	190±3	22±0.5	39±1	5.0±0.5	20±0.5
H	I	J	K	L		
43.5±1	2.3MAX	0.8±0.1	1.8MAX	2.3MAX		

注:

1. J,K,L 尺寸不含进线和双面胶
2. 大磁片 43.5*5*0.8 双槽 小磁片 20*8*0.8 带孔无槽
3. 线圈引线处贴 8MM 高温胶带, 缠绕 1.5~2 圈
4. 隔磁片背面贴双面胶带手撕位

二、原理图 SCHEMATIC DIAGRAM:



三、绕线参数 Winding Specification:

线材 Wire	圈数 Turns	绕线方向 Winding Direction
丝包线 0.08*70	10TS	反绕

四、电气特性 ELECTRICAL CHARACTERISTICS:

温度 TEMPERATURE: $25 \pm 10^{\circ}\text{C}$, 湿度 RELATIVE HUMIDITY : $65 \pm 20\%$

项目 TIEM	标准 SPECIFICATION	测试条件 TEST FREQUENCY	测试仪器 TEST EQUIPMENTS
IND	$7.0\mu\text{H} \pm 10\%$	100 KHZ/1.0V	LCRMETRTH2830N
DCR	$65\text{m}\Omega$ Max		PH2511S
Q	60 Min	100 KHZ/1.0V	LCRMETRTH2830N
gain	0 DB		

拟制 PREPARED BY	审核 CHECKED BY	日期 DATE
杨茂新	刘惜姜	20220829



承认书

SPECIFICATION FOR APPROVAL

客户:

CUSTOMER: 深圳市分寸科技有限公司

客户料号:

CUST P/N:

产品型号: J-FCA11L10

DESC:

日期: 20220829

DATE:

版本:

VERSION: A.0

拟制 PREPARED BY	审核 CHECKED BY	批准 APPROVED BY	客户承认 CUSTOMER APPROVE
杨茂新	刘惜姜	罗杰	

东莞市吉欧电子科技有限公司

DONGGUAN JIOU ELECTRONIC TECHNOLOGY CO,LTD

公司地址: 东莞市石碣镇新发工业区

TEL:0769-83067050

E-mail: lybofmana@163.com

DONGGUAN JIOU ELECTRONIC TECHNOLOGY CO, LTD

东莞市吉欧电子科技有限公司

版本变更履历

Version Change History

版本 Rev	变更前 Before Change	变更后 After Change	更改日期 Change Date	批准 Approved BY
A.0	新发行		20220829	罗杰

SPECIFICATION

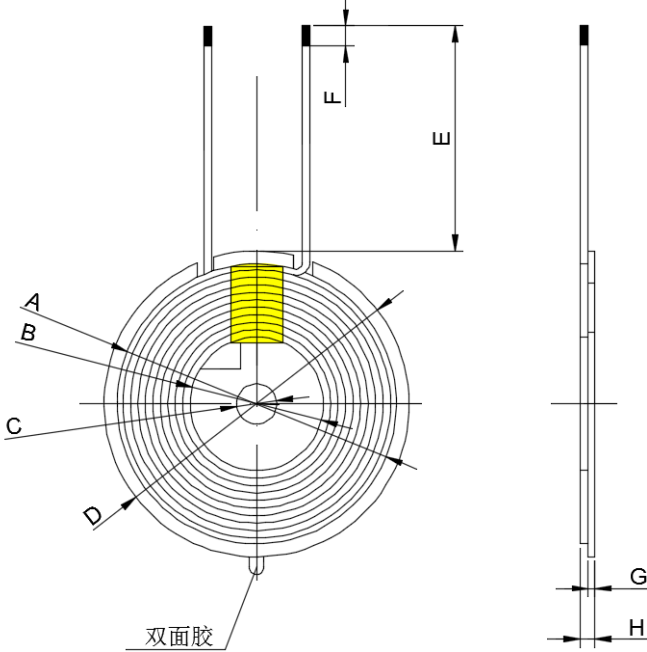
产品型号 DESC	J-FCA11L10	版本 REV:A.O	客户 CUST	尺寸
			客户料号 CUST P/N	
一、尺寸 DIMENSION(MM)				
			A	43±1mm
			B	20.5±0.5 mm
			C	5±0.5 mm
			D	50±1mm
			E	10±2 mm
			F	3±2 mm
			G	1±0.1 mm
			H	3.0Max
二、绕线参数 Winding Specification:				
线材 Wire	圈数 Turns	绕线方向 Winding Direction		
丝包线 0.08*105P	10TS	反绕		
三、电气特性 ELECTRICAL CHARACTERISTICS:				
温度 TEMPERATURE:25±10℃,湿度 RELATIVE HUMIDITY :65±20%				
项目 TIEM	标准 SPECIFICATION	测试条件 TEST FREQUENCY	测试仪器 TEST EQUIPMENTS	
IND	6.4UH±10%	100 KHZ/1.0V	LCZ METER 1062B	
DCR	55mΩ Max		LCZ METER 1062B	
gain	0DB			
拟制 PREPARED BY	审核 CHECKED BY	日期 DATE		
杨茂新	刘惜姜	20220829		

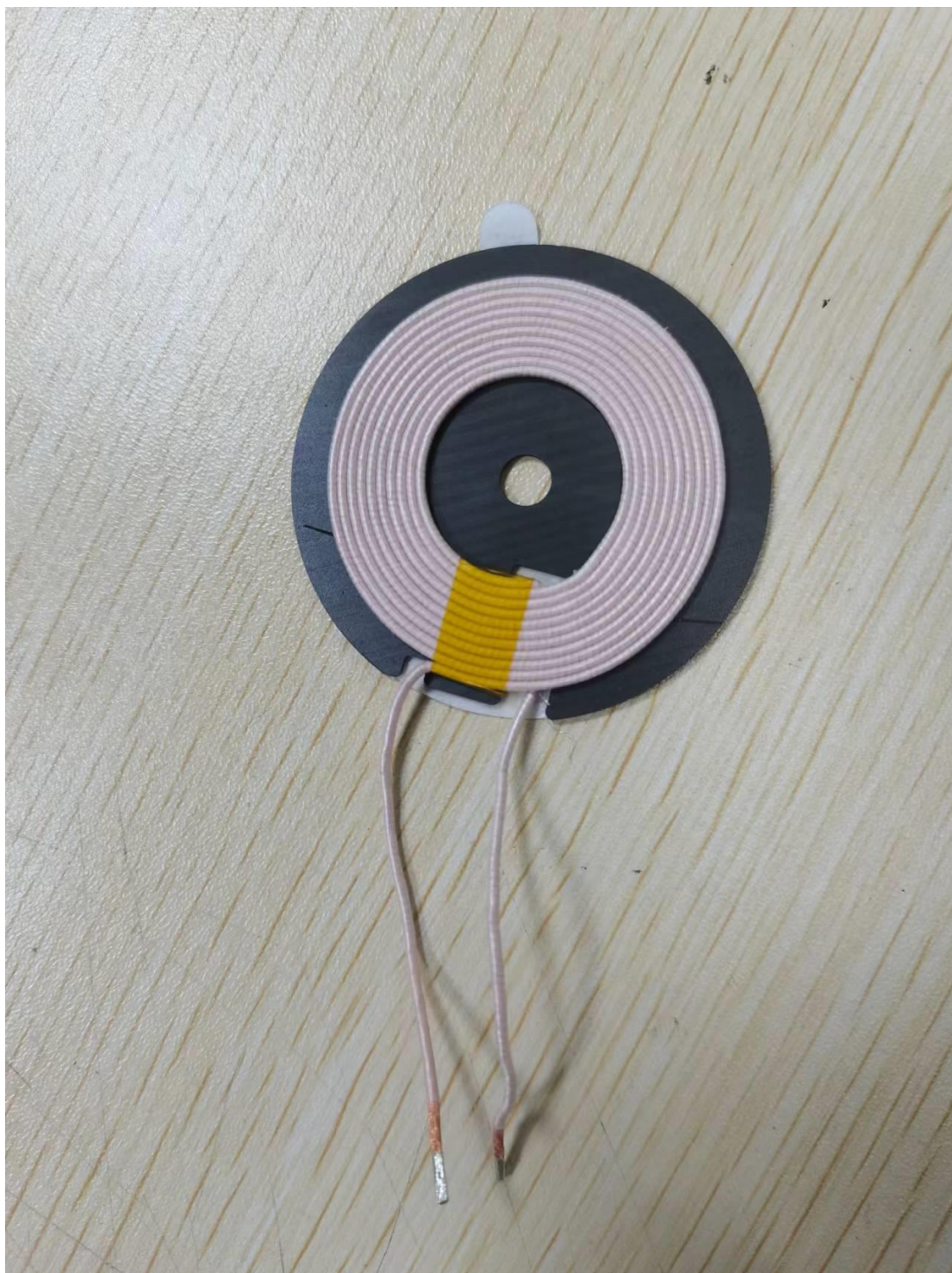

Acknowledgment

ROHS

CUSTOMER: Shenzhen Future Charger Technology Co. Ltd.

CUSTOMER P/N:0001.DZ.0010.0110

DESCRIPTION :

DATE:2022-8-29

SPECIFICATION: Watch coil soft magnetic-6.7uH

REV. NO. :A0

Acknowledgement, signature and seal for HRSW ELECTRONICS CO.,LTD

department	confirm/date	examine/date	approval/date	(Seal of the Company)
Quality	董晚红 2022-8-29	吕惠 2022-8-29	韦函满 2022-8-29	
engineering	何伟华 2022-8-29	韦立红 2022-8-29	韦立红 2022-8-29	

remarks:

Acknowledgement, signature and seal for Shenzhen Future Charger Technology Co. Ltd.

departme	confirm/date	examine/date	approval/date	(Seal of the Company)
R&D				
purchase				
Quality				

remarks:

深圳市鸿日昇威科技有限公司

HRSW ELECTRONICS CO.,LTD

ADD: Floor 2, Building 1, No. 48 Huanguan Middle Road, Guanlan, Longhua New District, Shenzhen

TEL: +86-755-23461055 FAX: +86-0755-28015170

SPECIFICATION FOR APPROVAL

1. MECHANICAL DIMENSION (UNIT:mm)

2. SCHEMATICS:

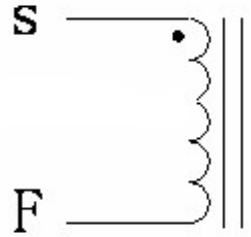
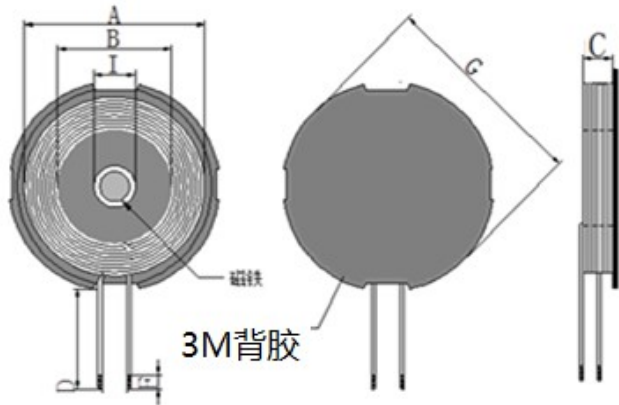

A	B	C	D	F	G				
20±2	14±1	2.7±0.5	15±2	4±2	25±2				

3. WINDING:

STEP	START-FINISH	WIRE TYPE	TURNS	TAPE	REMARK
N1	S-F	□0.08*24mm 2UEW	12TS (Ref)		

4. ELECTRICAL SPECIFICATION:

ITEM	L	DCR	IDC	Q值	HI-POT
TEST	S-F	S-F	S-F		
CON	100KHz, 0.25V	AT 25°C	AT 25°C		
SPEC	6.7uH±10%	40mΩ (Max)	3A		

5. BILF OF MATERIAL:

NO.	ITEM	MATERIAL SPECIFICATION	MANUFACTURER	SGS NO.
1	Magnetic core	UG25 soft magnetic	NANJINGJINNINGCO,LTD	
2	magnetic	N52 7.8*2.2	NANJINGJINNINGCO,LTD	
3	Copper wire	□0.08mm*24 2UEW	TAIYI CO.,LTD	
4	Gum backing	23 Single side adhesive	HONGBAOJEICO,LTD	
5	Solder Bar	Solder Bar	QIANDAO CO.,LTD	
6	glue	9999	CUDAK CO.,LTD	

HRSW ELECTRONICS CO., LTD	PART NO	
	TITLE	Watch coil soft magnetic-6.7uH
DRAWN BY	CHECKED BY	APPROVED BY
谢超	何伟华	韦立红

SPECIFICATION FOR APPROVAL

6. SAMPLE TEST DATA

6.1 DIMENSION TEST (UNIT:mm)

TEST ITEM	A	B	C	D	F	G		
	20±2	14±1	2.7±0.5	15±2	4±2	24±2		
1	20.08	13.95	2.74	15.2	3.25	24.30		
2	21.035	14.02	2.71	14.9	3.34	24.60		
3	21.04	13.98	2.68	15	4.02	24.80		
4	21.03	14	2.67	15.02	3.98	25.00		
5	20.98	14.05	2.69	14.89	3.89	25.37		
MAX	21.04	14.05	2.74	15.20	4.02	25.37		
MIN	20.08	13.95	2.67	14.89	3.25	24.30		
AVERAGE	20.76	14.00	2.70	15.01	3.68	24.82		

6.2 ELECTRICAL TEST

TEST ITEM	L		DCR	IDC		Q	HI-POT	
	S-F		S-F					
TEST COND	100KHz/0.25v		AT 25°C					
SPEC	6.7uH ±10%		40mΩ (Max)					
1	6.71		21.00					
2	6.98		20.00					
3	6.72		21.50					
4	6.70		20.30					
5	6.98		20.40					
6								
MAX	6.98		21.50					
MIN	6.70		20.00					
AVERAGE	6.84		20.75					

HRSW ELECTRONICS CO., LTD

PART NO

TITLE

Watch coil soft
magneti-6.7uH

DRAWN BY

CHECKED BY

APPROVED BY

谢超

何伟华

韦立红

