

承认书

SPECIFICATION FOR APPROVAL

客户:

CUSTOMER: 深圳市分寸科技有限公司

客户料号:

CUST P/N:

产品型号: J-FCA11L10

DESC:

日期: 20220829

DATE:

版本:

VERSION: A.0

| 拟制 PREPARED BY | 审核 CHECKED BY | 批准 APPROVED BY | 客户承认 CUSTOMER APPROVE |
|-------------------|------------------|-------------------|--------------------------|
| 杨茂新 | 刘惜姜 | 罗杰 | |

东莞市吉欧电子科技有限公司

DONGGUAN JIOU ELECTRONIC TECHNOLOGY CO,LTD

公司地址: 东莞市石碣镇新发工业区

[TEL:0769-83067050](tel:0769-83067050)

E-mail: lybofmana@163.com

DONGGUAN JIOU ELECTRONIC TECHNOLOGY CO, LTD

东莞市吉欧电子科技有限公司

SPECIFICATION

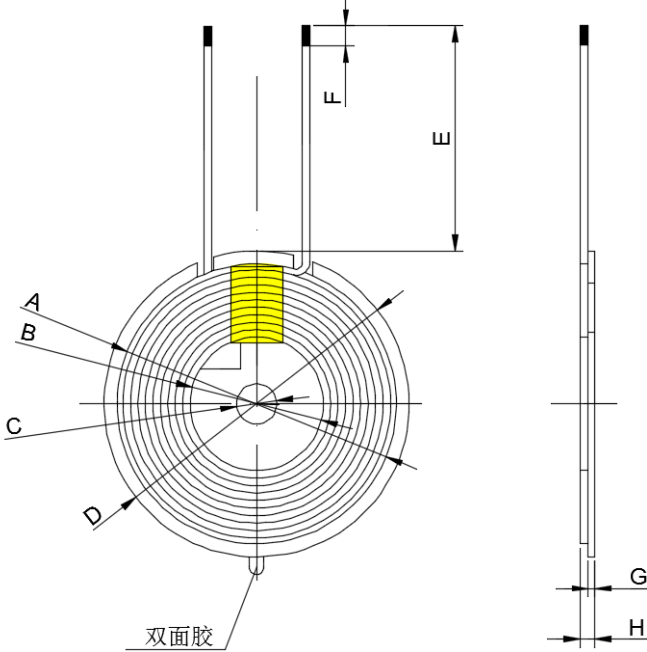
| | | | | |
|--|---------------------|---------------------------|-----------------------------|----------------|
| 产品型号 DESC | J-FCA11L10 | 版本 REV:A.O | 客户 CUST 客户料号 CUST P/N | 尺寸 |
| 一、尺寸 DIMENSION(MM) | | | | |
|  | | | A | 43±1mm |
| | | | B | 20.5±0.5 mm |
| | | | C | 5±0.5 mm |
| | | | D | 50±1mm |
| | | | E | 10±2 mm |
| | | | F | 3±2 mm |
| | | | G | 1±0.1 mm |
| | | | H | 3.0Max |
| 二、绕线参数 Winding Specification: | | | | |
| 线材 Wire | 圈数 Turns | 绕线方向 Winding Direction | | |
| 丝包线 0.08*105P | 10TS | 反绕 | | |
| 三、电气特性 ELECTRICAL CHARACTERISTICS: | | | | |
| 温度 TEMPERATURE:25±10℃,湿度 RELATIVE HUMIDITY :65±20% | | | | |
| 项目 TIEM | 标准 SPECIFICATION | 测试条件 TEST FREQUENCY | 测试仪器 TEST EQUIPMENTS | |
| IND | 6.4UH±10% | 100 KHZ/1.0V | LCZ METER 1062B | |
| DCR | 55mΩ Max | | LCZ METER 1062B | |
| gain | 0DB | | | |
| 拟制 PREPARED BY | 审核 CHECKED BY | 日期 DATE | | |
| 杨茂新 | 刘惜姜 | 20220829 | | |

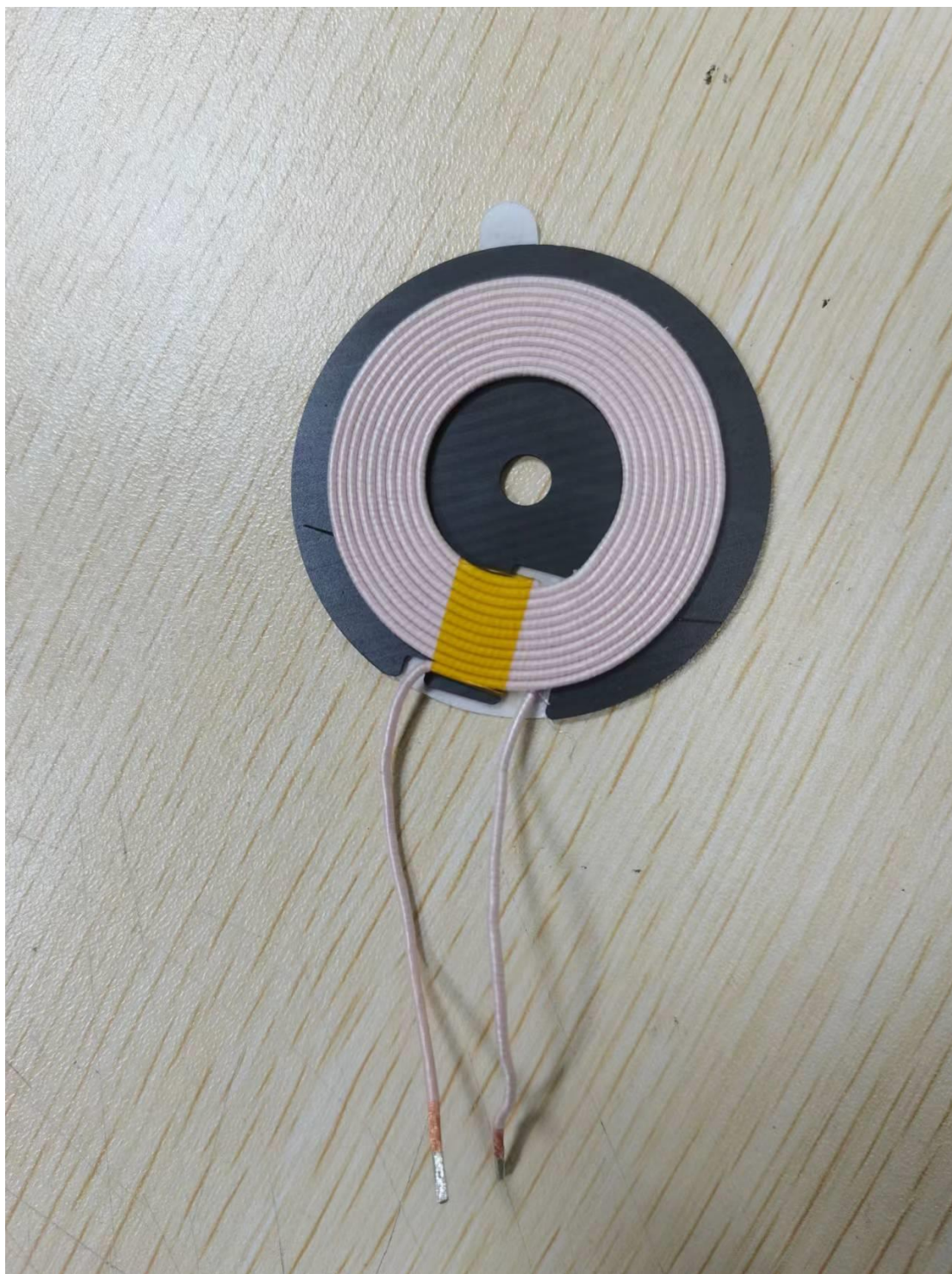

承认书

SPECIFICATION FOR APPROVAL

客户:

CUSTOMER: 深圳市冲向未来科技有限公司

客户料号:

CUST P/N:

产品型号: J-FCTM19-L190

DESC:

日期: 20220829

DATE:

版本:

VERSION: A.0

| 拟制 PREPARED BY | 审核 CHECKED BY | 批准 APPROVED BY | 客户承认 CUSTOMER APPROVE |
|-------------------|------------------|-------------------|--------------------------|
| 杨茂新 | 刘惜姜 | 罗杰 | |

东莞市吉欧电子科技有限公司

DONGGUAN JIOU ELECTRONIC TECHNOLOGY CO,LTD

公司地址: 东莞市石碣镇新发工业区

TEL:0769-83067050

E-mail: lybofmana@163.com

SPECIFICATION

| | | | | |
|--------------|---------------|---------------|------------------|--|
| 产品型号 DESC | J-FCTM19-L190 | 版本 REV:A.O | 客户 CUST | |
| | | | 客户料号 CUST P/N | |

一、 尺寸 DIMENSION(MM)

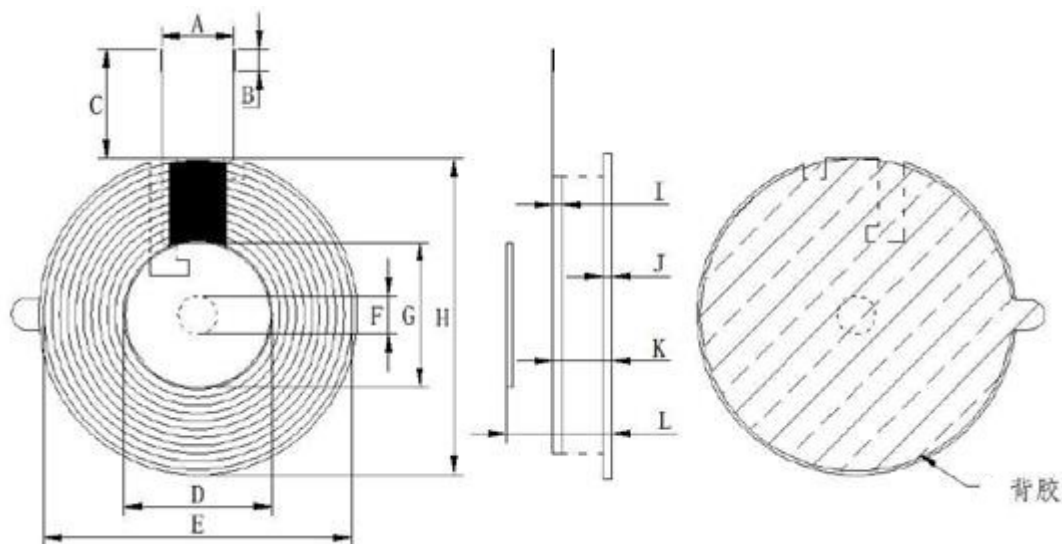

| A | B | C | D | E | F | G |
|----------|--------|---------|--------|--------|---------|--------|
| 10±2 REF | 3±1.5 | 190±3 | 22±0.5 | 39±1 | 5.0±0.5 | 20±0.5 |
| H | I | J | K | L | | |
| 43.5±1 | 2.3MAX | 0.8±0.1 | 1.8MAX | 2.3MAX | | |

注:

1. J,K,L 尺寸不含进线和双面胶
2. 大磁片 43.5*5*0.8 双槽 小磁片 20*8*0.8 带孔无槽
3. 线圈引线处贴 8MM 高温胶带, 缠绕 1.5~2 圈
4. 隔磁片背面贴双面胶带手撕位

二、原理图 SCHEMATIC DIAGRAM:



三、绕线参数 Winding Specification:

| 线材 Wire | 圈数 Turns | 绕线方向 Winding Direction |
|-------------|-------------|---------------------------|
| 丝包线 0.08*70 | 10TS | 反绕 |

四、电气特性 ELECTRICAL CHARACTERISTICS:

温度 TEMPERATURE: $25 \pm 10^{\circ}\text{C}$, 湿度 RELATIVE HUMIDITY : $65 \pm 20\%$

| 项目 TIEM | 标准 SPECIFICATION | 测试条件 TEST FREQUENCY | 测试仪器 TEST EQUIPMENTS |
|------------|---------------------------|------------------------|-------------------------|
| IND | $7.0\mu\text{H} \pm 10\%$ | 100 KHZ/1.0V | LCRMETRTH2830N |
| DCR | $65\text{m}\Omega$ Max | | PH2511S |
| Q | 60 Min | 100 KHZ/1.0V | LCRMETRTH2830N |
| gain | 0 DB | | |
| | | | |

| 拟制 PREPARED BY | 审核 CHECKED BY | 日期 DATE |
|-------------------|------------------|------------|
| 杨茂新 | 刘惜姜 | 20220829 |

