

承 認 書



SPECIFICATION FOR APPROVAL

客 戶:
CUSTOMER:

客 戶 料 號:
CUST P/N:

10.0110.1493

西联干城 料 號:
FINE P/N:

G45-6.8UH 单线圈 single-coil
0.08*24P*2-10TS 热风线 Hot air line

產 品 型 號:
DESC:

Φ43.5MMX5.2MMX0.8MM

日 期:
DATE:

2022/07/22

版 本:
Version:

A.0

擬制 PREPARED BY	審核 CHECKED BY	批准 APPROVED BY	客戶承認 CUSTOMER APPROVE
HUANG YANMING	NING YUANAN	HUANG JINHUA	

SPECIFICATION

產品型號: DESC	G45-6.8uH-0.08x24PX2-140mm	版本 Rev: A.0	客戶 CUST: 客戶料号 CUST P/N:	XXX
---------------	----------------------------	----------------	----------------------------	------------

一、尺寸 DIMENSION:(mm)

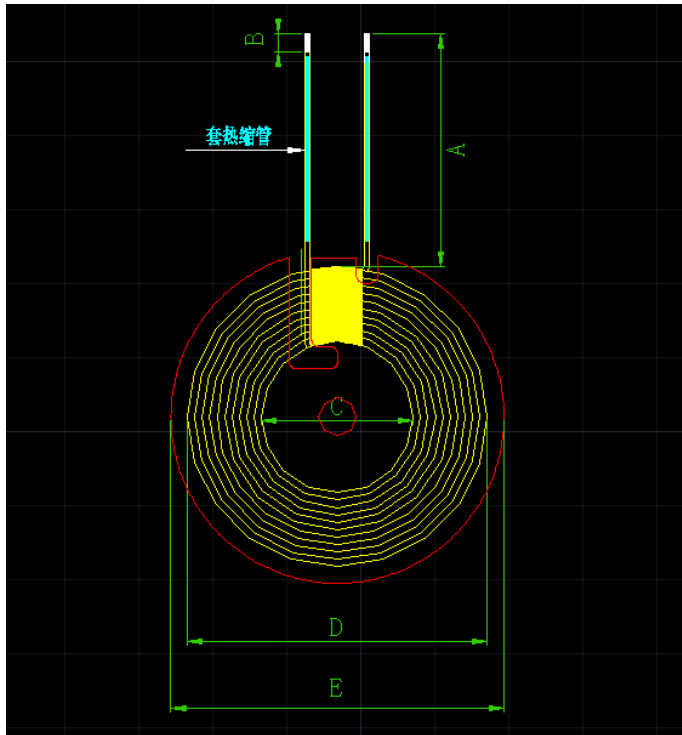

A	140±3
B	3±2
C	20±1
D	39±1
E	43.5±0.5

注:

1. 交叉出线;内引线穿孔
2. 出线位置无高温胶带
3. 线圈贴罐形软磁磁片, 磁片尺寸 43.5mm*5.2mm*0.8mm
4. 引线套热缩管

二、原理图 SCHEMATIC DIAGRAM:

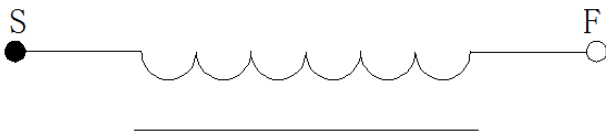

Note:

1. Cross outgoing line; Inner lead perforation
2. There is no high-temperature tape at the outlet position
3. The coil is attached to a can shaped soft magnetic disk, with a size of 43.5mm * 5.2mm * 0.8mm
4. Lead sleeve heat shrink tube

三、绕线参数 Winding Specification:

序号 NO.	端子 TERMINAL	线径 WIRE	圈数 Turns	绕线方向 Winding Direction
1	S F	热风线线 Hot air line 0.08*24PX2	10TS	CCW

四、电气特性 ELECTRICAL CHARACTERISTICS:

温度 TEMPERATURE:25±10℃, 湿度 RELATIVE HUMIDITY:65±20%

序号 NO.	项目 ITEM	端子 TERMINAL	标准 SPECIFICATION	测试条件 TEST FREQUENCY	测试仪器 TEST EQUIPMENTS
1	IND.	S-F	3.8uH ±20%单独线圈 single-coil	100KHz/0.25V	LCZ METER 1062B
2	IND.	S-F	6.8uH ±10%加磁片 Add magnetic disks	100KHz/0.25V	LCZ METER 1062B
3	DCR	S-F	≥90mΩ	100KHz/0.25V	LCZ METER 502B
4	Q	S-F	≥36	100KHz/0.25V	LCZ METER 502B

拟制/日期 PREPARED BY/DATE	审核/日期 CHECKED BY/DATE
HUANG YANMING 2022/07/22	HUANG JIANHUA 2022/07/22