

**ELECTROMAGNETIC EMISSIONS COMPLIANCE REPORT
INTENTIONAL RADIATOR CERTIFICATION TO
FCC PART 15 SUBPART C REQUIREMENT**

OF

Yoga 3 in 1 Wireless Charging Stand

**Model No.: A31FWCWH, A31FWCBK, A31FWCWHAU, A31FWCBKAU,
A31FWCXX, A31FWCXXAU (XX represents color)**

FCC ID: 2ATCA-A31FWC

Report No.: E04A23080945F00101

Issue Date: September 17, 2023

Trademark:  **ALOGIC**

Prepared for

ALOGIC Corporation Pty Ltd.

Level 40, 140 William Street Melbourne, VIC Australia 3000

Prepared by

Guangdong Global Testing Technology Co., Ltd.

**Room 101-105, 203-210, Building 1, No.2, Keji 8 Road, Songshan
Lake Park, Dongguan city, Guangdong, People' s Republic of China,
523808**

**This report shall not be reproduced, except in full, without the written approval of
Guangdong Global Testing Technology Co., Ltd.**

VERIFICATION OF COMPLIANCE

Applicant:	ALOGIC Corporation Pty Ltd. Level 40, 140 William Street Melbourne, VIC Australia 3000
Manufacturer:	ALOGIC Corporation Pty Ltd. Level 40, 140 William Street Melbourne, VIC Australia 3000
Product Description:	Yoga 3 in 1 Wireless Charging Stand
Trade Mark:	
Model Number:	A31FWCWH
Series Model:	A31FWCBK, A31FWCWHAU, A31FWCBKAU, A31FWCXX, A31FWCXXAU(XX represents color)

We hereby certify that:

The above equipment was tested by Guangdong Global Testing Technology Co., Ltd. The test data, data evaluation, test procedures, and equipment configurations shown in this report were made in accordance with the procedures given in ANSI C63.10-2013 and the energy emitted by the sample EUT tested as described in this report is in compliance with conducted and radiated emission limits of FCC Rules Part 15.209(2022).

Date of Test : September 7, 2023 to September 12, 2023

Prepared by :

Alan He/Editor

Reviewer &
Authorized Signer :

Shawn Wen/ Laboratory Manager



Modified Information

Version	Summary	Revision Date	Report No.
Ver.1.0	Original Report	/	E04A23080945F00101

Table of Contents

1 GENERAL INFORMATION	4
1.1 PRODUCT DESCRIPTION	4
1.2 RELATED SUBMITTAL(S) / GRANT(S)	5
1.3 TEST METHODOLOGY	5
1.4 SPECIAL ACCESSORIES	5
1.5 EQUIPMENT MODIFICATIONS	5
1.6 TEST FACILITY	5
2 SYSTEM TEST CONFIGURATION.....	6
2.1 EUT CONFIGURATION	6
2.2 EUT EXERCISE	6
2.3 TEST PROCEDURE	6
2.4 CONFIGURATION OF TESTED SYSTEM.....	7
3 SUMMARY OF TEST RESULTS.....	7
4 TEST SYSTEM UNCERTAINTY.....	8
5 CONDUCTED EMISSIONS TEST	9
5.1 MEASUREMENT PROCEDURE	9
5.2 TEST SET-UP (BLOCK DIAGRAM OF CONFIGURATION)	9
5.3 MEASUREMENT EQUIPMENT USED.....	9
5.4 CONDUCTED EMISSION LIMIT	9
5.5 MEASUREMENT RESULT	10
5.6 CONDUCTED MEASUREMENT PHOTO.....	13
6 RADIATED EMISSION TEST.....	14
6.1 MEASUREMENT PROCEDURE	14
6.2 TEST SET-UP (BLOCK DIAGRAM OF CONFIGURATION)	14
6.3 MEASUREMENT EQUIPMENT USED.....	15
6.4 RADIATED EMISSION LIMIT	15
6.5 MEASUREMENT RESULT	17
6.6 RADIATED MEASUREMENT PHOTOS.....	23
7 20DB BANDWIDTH	24
7.1 20DB BANDWIDTH LIMIT	24
7.2 TEST INSTRUMENTS.....	24
7.3 TEST PROCEDURE	24
7.4 TEST SETUP.....	24
7.5 TEST RESULT	24
8 ANTENNA APPLICATION	27
8.1 ANTENNA REQUIREMENT	27
8.2 RESULT	27

1 General Information

1.1 Product Description

Characteristics	Description
Product Name	Yoga 3 in 1 Wireless Charging Stand
Model number	A31FWCWH
Series Model	A31FWCBK, A31FWCWHAU, A31FWCBKAU, A31FWCXX, A31FWCXXAU(XX represents color)
Operation Mode	Wireless Charging
Input Rating	USB-C:5V===3A/9V===3A
Power Supply	DC 5V/9V
Operating Frequency	110-205KHz for phone charging 300-350KHz for Watch charging 110-205KHz for Earphone charging
Wireless Charging Power	15W(Max) for phone charging 1.5W(Max) for Watch charging 5W(Max) for Earphone charging
Modulation Technique	FSK for phone charging ASK for Watch charging ASK for Earphone charging
Antenna Type	Coil Antenna
Software version	V1.0
Hardware version	V1.2
Sample receipt date	September 5, 2023

1.2 Related Submittal(s) / Grant(s)

This submittal(s) (test report) is intended for FCC ID: 2ATCA-A31FWC filing to comply with the FCC Part 15, Subpart C Rules.

1.3 Test Methodology

Both conducted and radiated testing was performed according to the procedures in ANSI C63.10 (2013). Radiated testing was performed at an antenna to EUT distance 3 meters.

1.4 Special Accessories

Not available for this EUT intended for grant.

1.5 Equipment Modifications

Not available for this EUT intended for grant.

1.6 Test Facility

Site Description
Name of Firm : Guangdong Global Testing Technology Co., Ltd.
Site Location : Room 101-105, 203-210, Building 1, No.2, Keji 8 Road, Songshan Lake Park, Dongguan city, Guangdong, People' s Republic of China, 523808.

2 System Test Configuration

2.1 EUT Configuration

The EUT configuration for testing is installed on RF field strength measurement to meet the Commissions requirement and operating in a manner which intends to maximize its emission characteristics in a continuous normal application.

2.2 EUT Exercise

The Transmitter was operated in the normal operating mode. The TX frequency was fixed which was for the purpose of the measurements.

2.3 Test Procedure

2.3.1 Conducted Emissions

The EUT is placed on a turn table which is 0.8 m above ground plane. According to the requirements in Section 13.1.4.1 of ANSI C63.10-2013 Conducted emissions from the EUT measured in the frequency range between 0.15 MHz and 30 MHz using CISPR Quasi-Peak and average detector mode.

2.3.2 Radiated Emissions

The EUT is placed on a turn table which is 0.8 m above ground plane. The turn table shall rotate 360 degrees to determine the position of maximum emission level. EUT is set 3m away from the receiving antenna which varied from 1m to 4m to find out the highest emission. And also, each emission was to be maximized by changing the polarization of receiving antenna both horizontal and vertical. In order to find out the max. emission, the fixed in a particular direction according to the requirements in Section 13.1.4.1 of ANSI C63.10-2013.

2.4 Configuration of Tested System

Fig. 2-1 Configuration of Tested System

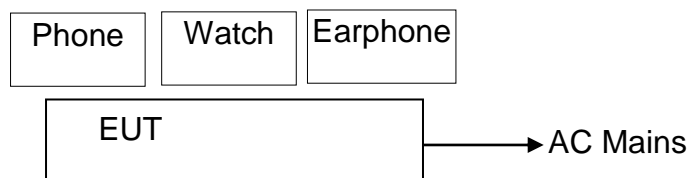

Table 2-1 Equipment Used in Tested System

Item	Equipment	Trade Mark	Model No.	FCC ID	Note
1.	Yoga 3 in 1 Wireless Charging Stand	/	A31FWCWH	2ATCA-A31FWC	EUT
2.	Adapter	/	580245A087	N/A	Support Equipment
3.	phone	Apple	A2176	N/A	Support Equipment
4.	Earphone	momax	X5	N/A	Support Equipment
5.	Watch	Apple	A1859	N/A	Support Equipment

Note:

- (1) Unless otherwise denoted as EUT in 『Remark』 column, device(s) used in tested system is a support equipment.

3 Summary of Test Results

FCC Rules	Description Of Test	Result
§15.207	AC Power Conducted Emission	Compliant
§15.209	Radiated Emission	Compliant
§2.1049	20dB Bandwidth	Compliant
§15.203	Antenna Requirement	Compliant

4 TEST SYSTEM UNCERTAINTY

The following measurement uncertainty levels have been estimated for tests performed on the apparatus:

Parameter	Uncertainty
Conducted Emissions Test	$\pm 2.0\text{dB}$
Radiated Emission Test	$\pm 2.0\text{dB}$
Temperature	$\pm 0.5^{\circ}\text{C}$
Humidity	$\pm 3\%$

Remark: The coverage Factor ($k=2$), and measurement Uncertainty for a level of Confidence of 95%

5 Conducted Emissions Test

5.1 Measurement Procedure

1. The EUT was placed on a table which is 0.8m above ground plane.
2. Maximum procedure was performed on the six highest emissions to ensure EUT compliance.
3. Repeat above procedures until all frequency measured was complete.

5.2 Test SET-UP (Block Diagram of Configuration)

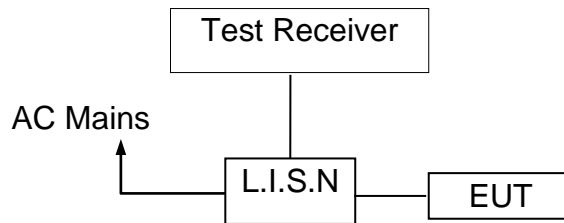

5.3 Measurement Equipment Used

Equipment	Manufacturer	Model No.	Serial No.	Last Cal.	Due Date
Shielded Room	CHENG YU	8m*5m*4m	N/A	2022/10/29	2025/10/28
EMI Test Receiver	Rohde & Schwarz	ESR3	102647	2022/12/03	2023/12/02
LISN/AMN	Rohde & Schwarz	ENV216	102843	2022/10/08	2023/10/07
NNLK 8129 RC	Schwarzbeck	NNLK 8129 RC	5046	2023/03/30	2024/03/29
Test Software	Farad	EZ-EMC (Ver. EMC-con-3A1 1+)	N/A	N/A	N/A

5.4 Conducted Emission Limit

Conducted Emission

Frequency(MHz)	Quasi-peak	Average
0.15-0.5	66-56	56-46
0.5-5.0	56	46
5.0-30.0	60	50

Note: 1. The lower limit shall apply at the transition frequencies

2. The limit decreases in line with the logarithm of the frequency in the range of 0.15 to 0.50MHz.

5.5 Measurement Result

Operation Mode:	TX	Test Date :	2023/9/8
Frequency Range:	0.15MHz~30MHz	Temperature :	26°C
Test Result:	PASS	Humidity :	54 %RH
Test By:	Rock		

We pretested modes (Wireless Charging(15W+5W+1.5W), Wireless Charging (7.5W+5W+1.5W),Wireless Charging(5W+5W+1.5W)) for EUT. The worst test data see follow the table.

Test mode: Wireless Charging 15W+5W+1.5W

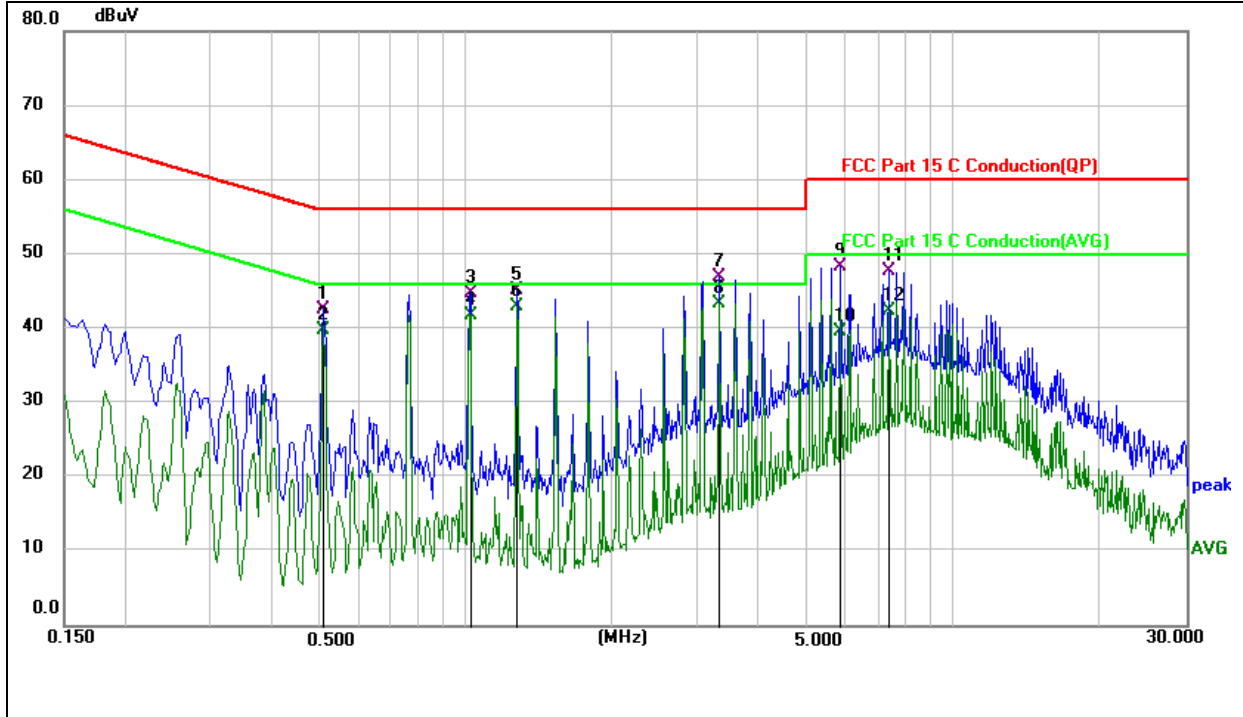

Limit:	FCC Part 15 C Conduction(QP)	Phase:	L1
EUT:	Yoga 3 in 1 Wireless Charging Stand	Test Time:	2023/9/8
M/N.:	A31FWCWH	Power Rating:	AC120V/60Hz
Mode:	Wireless Charging 15W+5W+1.5W	Test Engineer:	Rock

No.	Frequency (MHz)	Reading Level(dBuV)	Factor (dB)	Measurement(dBuV)	Limit (dBuV)	Over (dB)	Detector	Comment
1	0.5100	32.63	9.92	42.55	56.00	-13.45	QP	
2	0.5100	29.84	9.92	39.76	46.00	-6.24	AVG	
3	1.0230	34.92	9.80	44.72	56.00	-11.28	QP	
4	1.0230	31.92	9.80	41.72	46.00	-4.28	AVG	
5	1.2750	35.39	9.78	45.17	56.00	-10.83	QP	
6	1.2750	33.21	9.78	42.99	46.00	-3.01	AVG	
7	3.3135	36.90	9.97	46.87	56.00	-9.13	QP	
8	3.3135	33.34	9.97	43.31	46.00	-2.69	AVG	
9	5.8695	38.35	9.90	48.25	60.00	-11.75	QP	
10	5.8695	29.73	9.90	39.63	50.00	-10.37	AVG	
11	7.3950	37.75	10.05	47.80	60.00	-12.20	QP	
12	7.3950	32.27	10.05	42.32	50.00	-7.68	AVG	

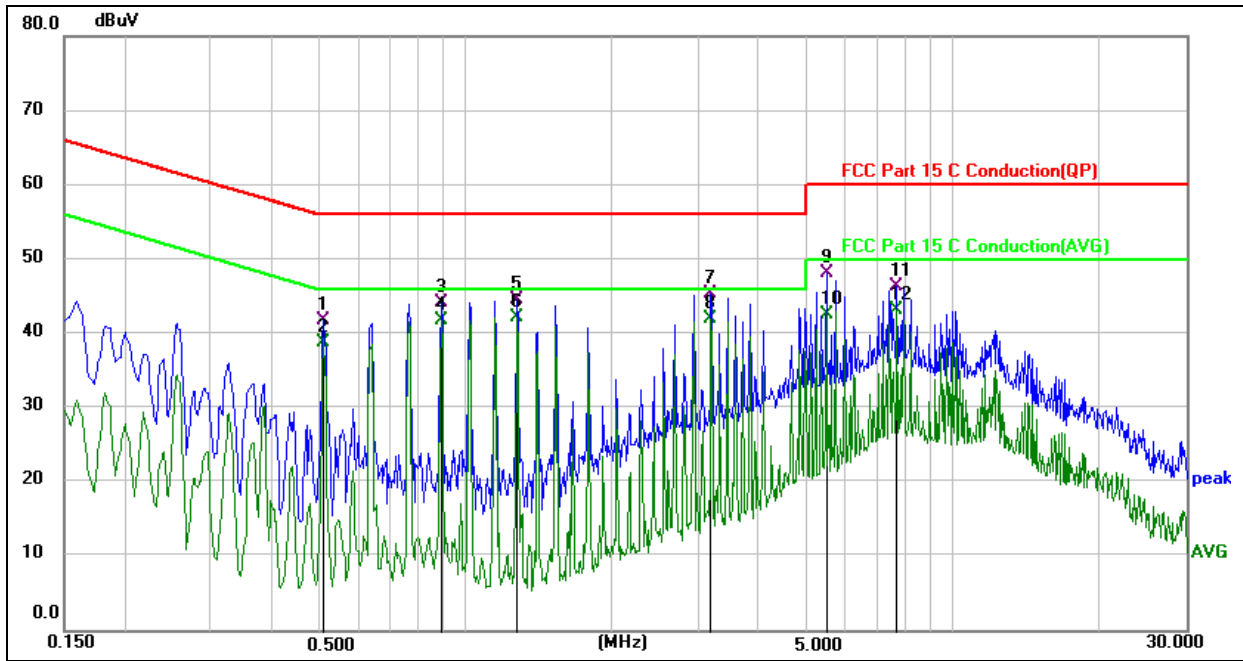

Limit:	FCC Part 15 C Conduction(QP)	Phase:	N
EUT:	Yoga 3 in 1 Wireless Charging Stand	Test Time:	2023/9/8
M/N.:	A31FWCWH	Power Rating:	AC120V/60Hz
Mode:	Wireless Charging 15W+5W+1.5W	Test Engineer:	Rock

No.	Frequency (MHz)	Reading Level(dBuV)	Factor (dB)	Measurement(dBuV)	Limit (dBuV)	Over (dB)	Detector	Comment
1	0.5100	31.89	9.90	41.79	56.00	-14.21	QP	
2	0.5100	28.95	9.90	38.85	46.00	-7.15	AVG	
3	0.8924	34.45	9.79	44.24	56.00	-11.76	QP	
4	0.8924	32.05	9.79	41.84	46.00	-4.16	AVG	
5	1.2750	34.82	9.78	44.60	56.00	-11.40	QP	
6	1.2750	32.31	9.78	42.09	46.00	-3.91	AVG	
7	3.1875	35.38	9.94	45.32	56.00	-10.68	QP	
8	3.1875	32.05	9.94	41.99	46.00	-4.01	AVG	
9	5.4870	38.20	9.93	48.13	60.00	-11.87	QP	
10	5.4870	32.67	9.93	42.60	50.00	-7.40	AVG	
11	7.6515	36.49	9.96	46.45	60.00	-13.55	QP	
12	7.6515	33.16	9.96	43.12	50.00	-6.88	AVG	

5.6 Conducted Measurement Photo



6 Radiated Emission Test

6.1 Measurement Procedure

1. The EUT was placed on a turn table which is 0.8m above ground plane.
2. Maximum procedure was performed on the six highest emissions to ensure EUT compliance.
3. And also, each emission was to be maximized by changing the polarization of receiving antenna both horizontal and vertical.
4. Repeat above procedures until all frequency measured were complete.

6.2 Test SET-UP (Block Diagram of Configuration)

(A) Radiated Emission Test Set-Up, Frequency Below 30MHz

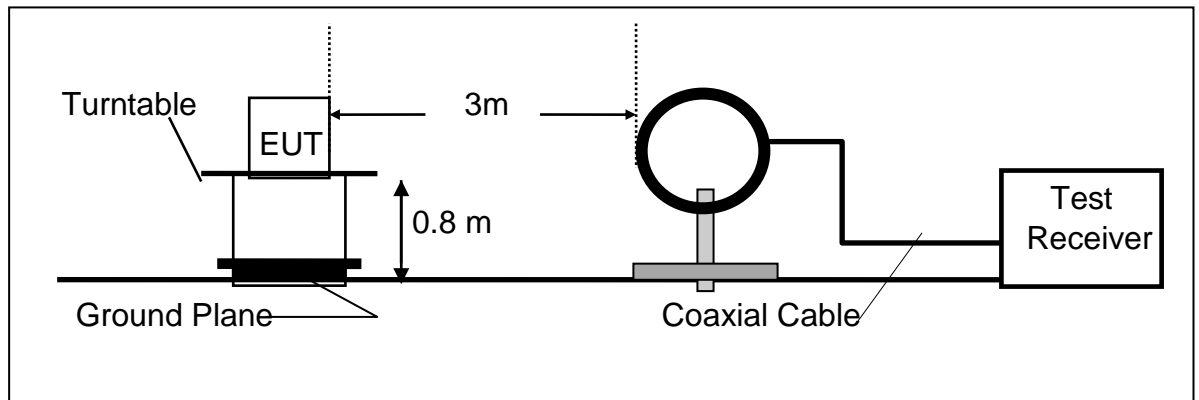

(B) Radiated Emission Test Set-Up, Frequency Below 1000MHz

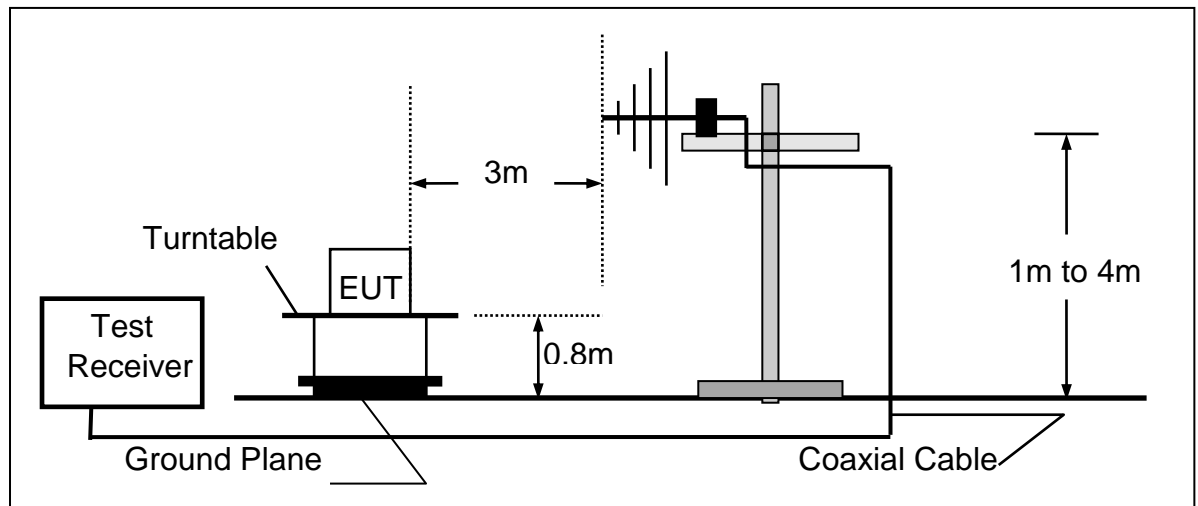

6.3 Measurement Equipment Used

Equipment	Manufacturer	Model No.	Serial No.	Last Cal.	Due Date
3m Semi-anechoic Chamber	ETS	9m*6m*6m	Q2146	2022/08/30	2025/08/29
EMI Test Receiver	Rohde & Schwarz	ESCI3	101409	2022/10/08	2023/10/07
Spectrum Analyzer	KEYSIGHT	N9020A	MY51283932	2022/10/08	2023/10/07
Pre-Amplifier	HzEMC	HPA-9K0130	HYP A21001	2022/10/29	2023/10/28
Biconilog Antenna	Schwarzbeck	VULB 9168	01315	2022/10/10	2025/10/09
Biconilog Antenna	ETS	3142E	00243646	2022/03/23	2025/03/22
Loop Antenna	ETS	6502	243668	2022/03/30	2025/03/29
Test Software	Farad	EZ-EMC Ver:ANCI-3A1	N/A	N/A	N/A

6.4 Radiated Emission Limit

The emissions from an intentional radiator shall not exceed the field strength levels specified in the following table 15.209(a):

FCC Part 15.209				
Frequency (MHz)	Field Strength Limitation		Field Strength Limitation Frequency tion at 3m Measurement Dist	
	(uV/m)	Dist	(uV/m)	(dBuV/m)
0.009 – 0.490	$2400 / F(\text{KHz})$	300m	$10000 * 2400/F(\text{KHz})$	$20\log 2400/F(\text{KHz}) + 80$
0.490 – 1.705	$24000 / F(\text{KHz})$	30m	$100 * 24000/F(\text{KHz})$	$20\log 24000/F(\text{KHz}) + 40$
1.705 – 30.00	30	30m	$100 * 30$	$20\log 30 + 40$
30.0 – 88.0	100	3m	100	$20\log 100$
88.0 – 216.0	150	3m	150	$20\log 150$
216.0 – 960.0	200	3m	200	$20\log 200$
Above 960.0	500	3m	500	$20\log 500$

15.205 Restricted bands of operation

MHz	MHz	MHz	GHz
0.090 - 0.110	16.42 - 16.423	399.9 - 410	4.5 - 5.15
¹ 0.495 - 0.505	16.69475 - 16.69525	608 - 614	5.35 - 5.46
2.1735 - 2.1905	16.80425 - 16.80475	960 - 1240	7.25 - 7.75
4.125 - 4.128	25.5 - 25.67	1300 - 1427	8.025 - 8.5
4.17725 - 4.17775	37.5 - 38.25	1435 - 1626.5	9.0 - 9.2
4.20725 - 4.20775	73 - 74.6	1645.5 - 1646.5	9.3 - 9.5
6.215 - 6.218	74.8 - 75.2	1660 - 1710	10.6 - 12.7
6.26775 - 6.26825	108 - 121.94	1718.8 - 1722.2	13.25 - 13.4
6.31175 - 6.31225	123 - 138	2200 - 2300	14.47 - 14.5
8.291 - 8.294	149.9 - 150.05	2310 - 2390	15.35 - 16.2
8.362 - 8.366	156.52475 - 156.52525	2483.5 - 2500	17.7 - 21.4
8.37625 - 8.38675	156.7 - 156.9	2690 - 2900	22.01 - 23.12
8.41425 - 8.41475	162.0125 - 167.17	3260 - 3267	23.6 - 24.0
12.29 - 12.293	167.72 - 173.2	3332 - 3339	31.2 - 31.8
12.51975 - 12.52025	240 - 285	3345.8 - 3358	36.43 - 36.5
12.57675 - 12.57725	322 - 335.4	3600 - 4400	(²)

- Remark:
1. Emission level in dBuV/m=20 log (uV/m)
 2. Measurement was performed at an antenna to the closed point of EUT distance of meters.
 3. Only spurious frequency is permitted to locate within the Restricted Bands specified in provision of ξ 15.205, and the emissions located in restricted bands also comply with 15.209 limit.

6.5 Measurement Result

We pretested modes (Wireless Charging(15W+5W+1.5W), Wireless Charging(7.5W +5W +1.5W),Wireless Charging(5W+5W+1.5W)) for EUT. The worst mode (Wireless Charging(15W +5W+1.5W))test data see follow the table.

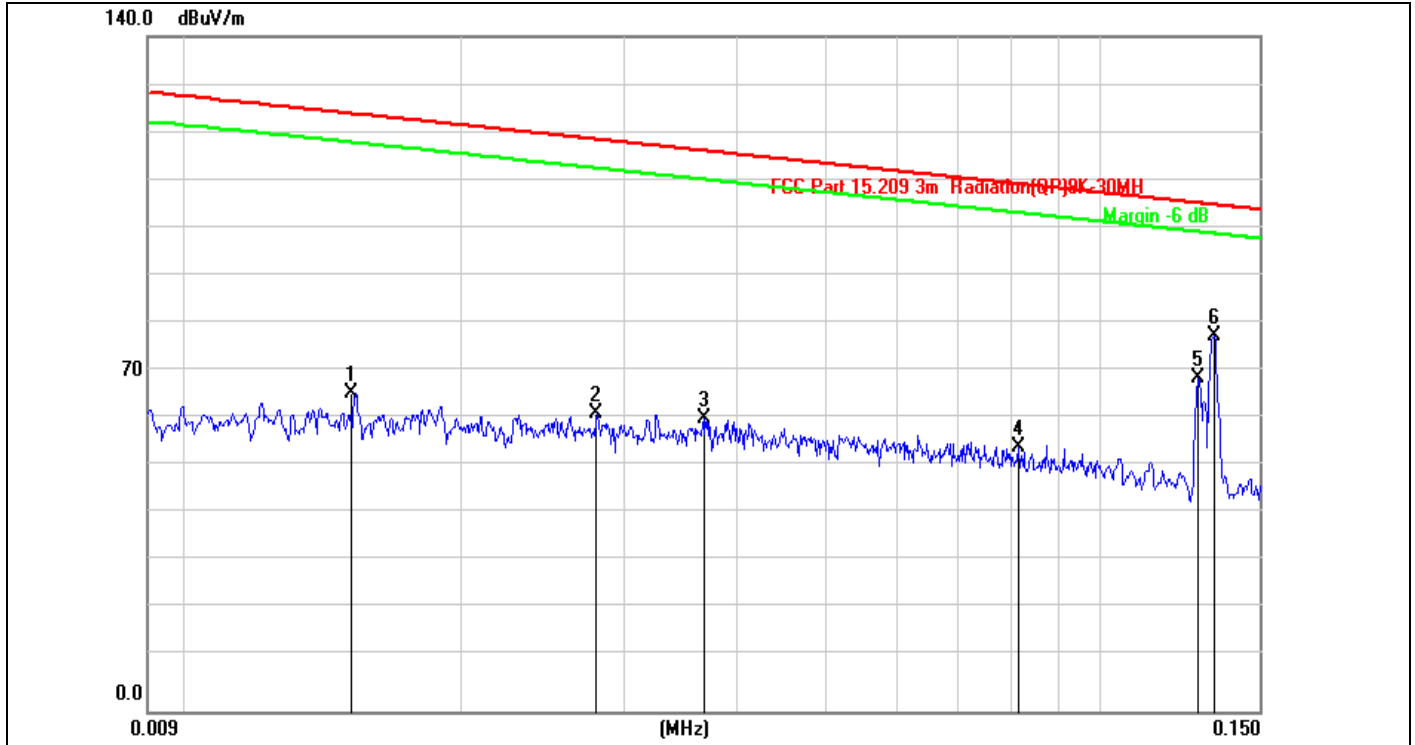

Limit:	FCC Part 15C 3m Radiation(QP)	Antenna:	Horizontal
EUT:	Yoga 3 in 1 Wireless Charging Stand	Temperature:	24.3°C
M/N.:	A31FWCWH	Humidity:	53.2%RH
Mode:	Wireless Charging 15W+5W+1.5W	Power Rating:	AC 120V/60Hz
Test Engineer:	Karry	Test Time:	2023/9/8

No.	Frequency (MHz)	Reading (dBuV)	Factor (dB/m)	Level (dBuV/m)	Limit (dBuV/m)	Margin (dB)	Det.	Height (cm)	Azimuth (deg)	Remark
1	0.0151	45.56	20.36	65.92	124.01	-58.09	QP	100	236	
2	0.0280	41.58	20.18	61.76	118.65	-56.89	QP	100	254	
3	0.0367	40.70	20.07	60.77	116.30	-55.53	QP	100	120	
4	0.0815	35.19	19.70	54.89	109.37	-54.48	QP	100	103	
5	0.1285	49.64	19.63	69.27	105.42	-36.15	QP	100	271	
6 *	0.1337	58.11	19.64	77.75	105.08	-27.33	QP	100	152	

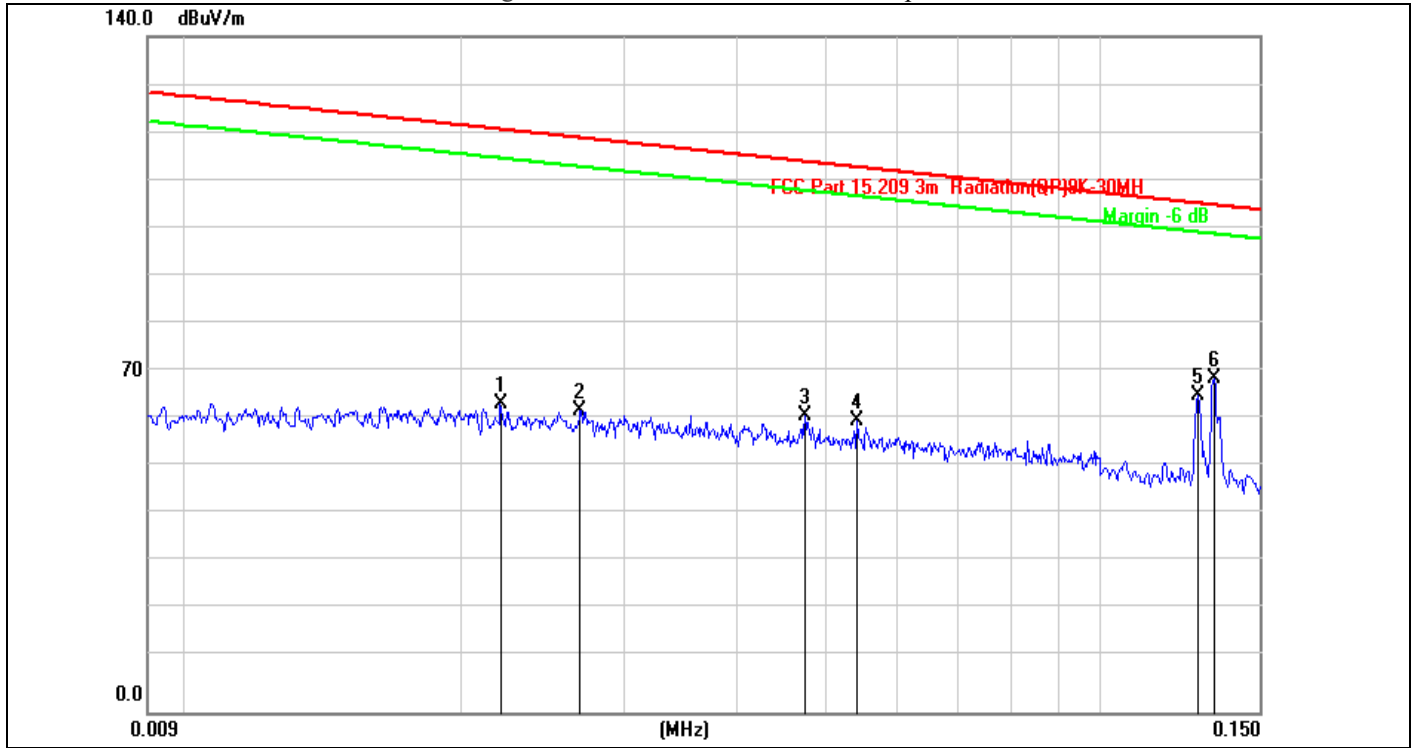

Limit:	FCC Part 15C 3m Radiation(QP)	Antenna:	Vertical
EUT:	Yoga 3 in 1 Wireless Charging Stand	Temperature:	24.3°C
M/N.:	A31FWCWH	Humidity:	53.2%RH
Mode:	Wireless Charging 15W+5W+1.5W	Power Rating:	AC 120V/60Hz
Test Engineer:	Karry	Test Time:	2023/9/8

No.	Frequency (MHz)	Reading (dBuV)	Factor (dB/m)	Level (dBuV/m)	Limit (dBuV/m)	Margin (dB)	Det.	Height (cm)	Azimuth (deg)	Remark
1	0.0220	43.71	20.26	63.97	120.74	-56.77	QP	100	236	
2	0.0269	42.39	20.19	62.58	119.00	-56.42	QP	100	254	
3	0.0475	41.49	19.96	61.45	114.06	-52.61	QP	100	120	
4	0.0542	40.55	19.88	60.43	112.91	-52.48	QP	100	103	
5	0.1285	46.14	19.63	65.77	105.42	-39.65	QP	100	271	
6 *	0.1337	49.42	19.64	69.06	105.08	-36.02	QP	100	152	

- Note:**
- (1) All Readings are Peak Value.
 - (2) Emission Level= Reading Level+Probe Factor +Cable Loss.
 - (3) The average measurement was not performed when the peak measured data under the limit of average detection.
 - (4) EUT lying on the table position is the worst case result in the report.

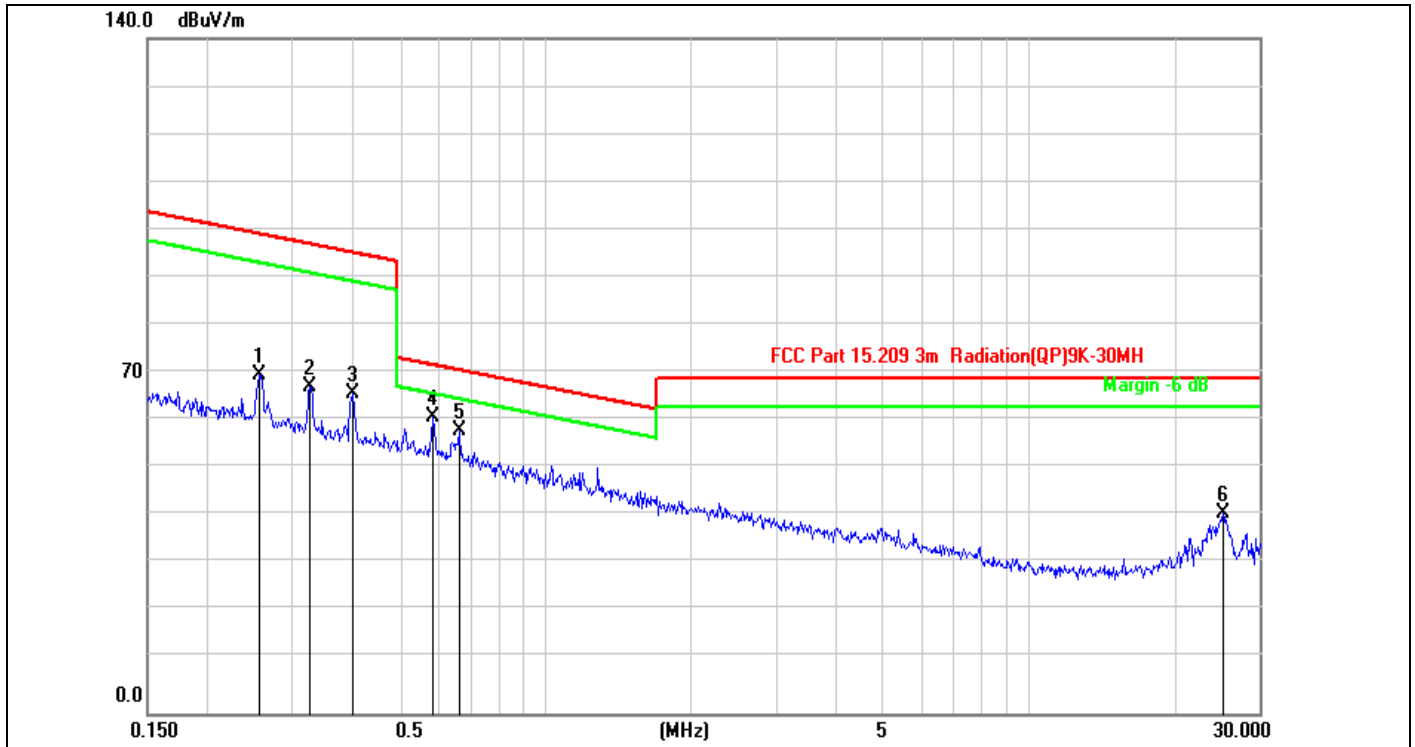

Limit:	FCC Part 15C 3m Radiation(QP)	Antenna:	Horizontal
EUT:	Yoga 3 in 1 Wireless Charging Stand	Temperature:	24.3°C
M/N.:	A31FWCWH	Humidity:	53.2%RH
Mode:	Wireless Charging 15W+5W+1.5W	Power Rating:	AC 120V/60Hz
Test Engineer:	Karry	Test Time:	2023/9/8

No.	Frequency (MHz)	Reading (dBuV)	Factor (dB/m)	Level (dBuV/m)	Limit (dBuV/m)	Margin (dB)	Det.	Height (cm)	Azimuth (deg)	Remark
1	0.2548	50.59	19.63	70.22	99.48	-29.26	QP	100	236	
2	0.3251	48.12	19.62	67.74	97.36	-29.62	QP	100	254	
3	0.3997	46.65	19.61	66.26	95.57	-29.31	QP	100	120	
4 *	0.5854	41.91	19.57	61.48	72.26	-10.78	QP	100	103	
5	0.6613	38.96	19.55	58.51	71.20	-12.69	QP	100	271	
6	25.1876	20.96	20.65	41.61	69.50	-27.89	QP	100	152	

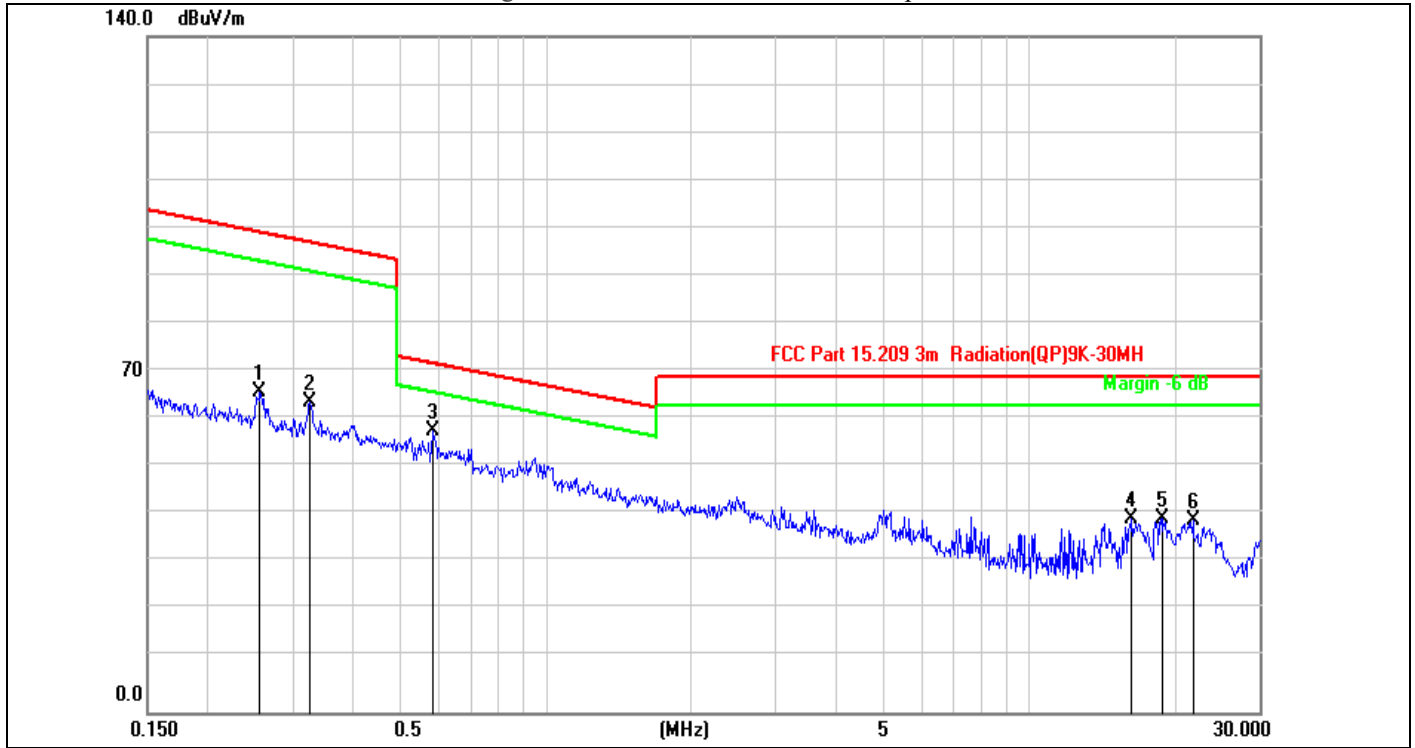

Limit:	FCC Part 15C 3m Radiation(QP)	Antenna:	Vertical
EUT:	Yoga 3 in 1 Wireless Charging Stand	Temperature:	24.3°C
M/N.:	A31FWCWH	Humidity:	53.2%RH
Mode:	Wireless Charging 15W+5W+1.5W	Power Rating:	AC 120V/60Hz
Test Engineer:	Karry	Test Time:	2023/9/8

No.	Frequency (MHz)	Reading (dBuV)	Factor (dB/m)	Level (dBuV/m)	Limit (dBuV/m)	Margin (dB)	Det.	Height (cm)	Azimuth (deg)	Remark
1	0.2562	46.65	19.63	66.28	99.43	-33.15	QP	100	236	
2	0.3251	44.44	19.62	64.06	97.36	-33.30	QP	100	254	
3 *	0.5854	38.62	19.57	58.19	72.26	-14.07	QP	100	120	
4	16.3118	19.71	20.54	40.25	69.50	-29.25	QP	100	103	
5	18.9205	19.21	20.96	40.17	69.50	-29.33	QP	100	271	
6	21.8303	18.65	21.19	39.84	69.50	-29.66	QP	100	152	

- Note:**
- (1) All Readings are Peak Value.
 - (2) Emission Level= Reading Level+Probe Factor +Cable Loss.
 - (3) The average measurement was not performed when the peak measured data under the limit of average detection.
 - (4) EUT lying on the table position is the worst case result in the report.

We pretested modes (Wireless Charging(15W+5W+1.5W),Wireless Charging (7.5W+5W+1.5W),Wireless Charging(5W+5W+1.5W)) for EUT. The worst test data (Wireless Charging(15W+5W+1.5W)) see follow the table.

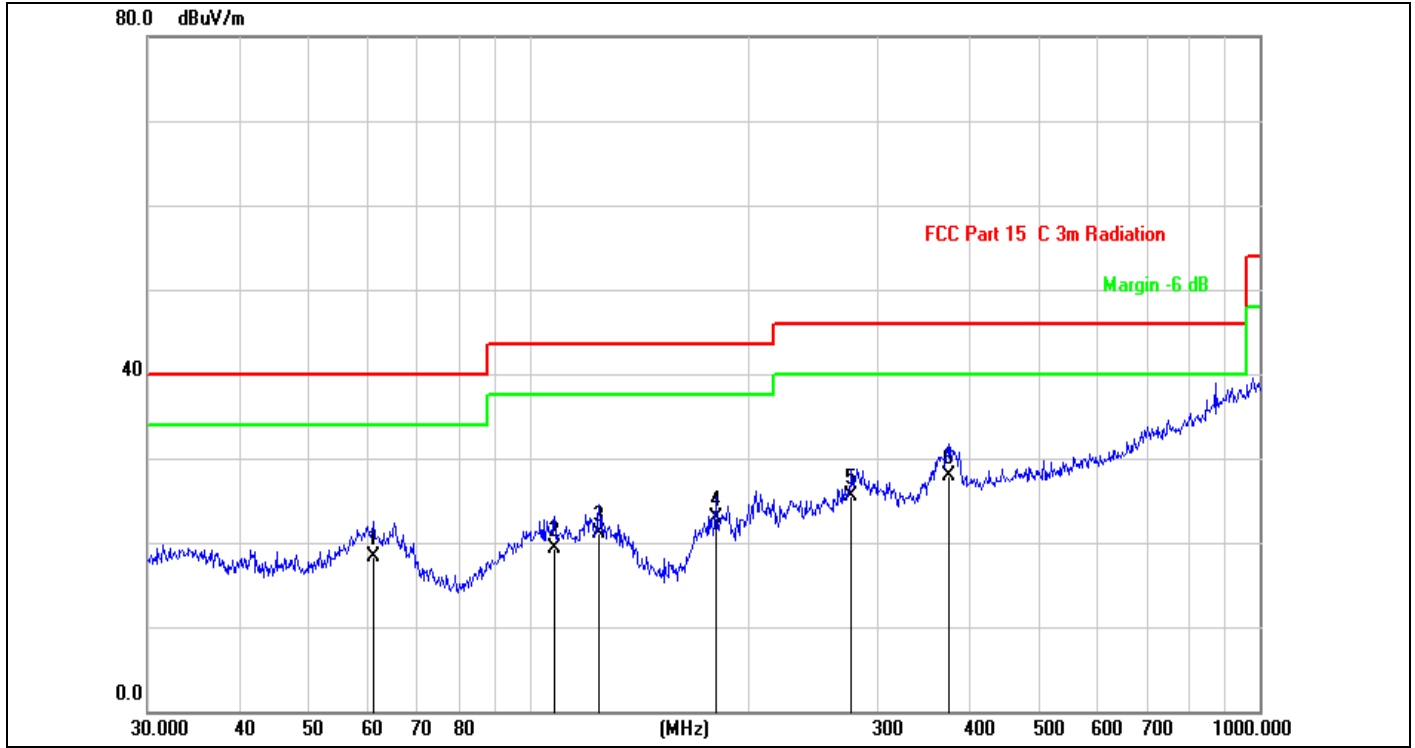

Limit:	FCC Part 15C 3m Radiation(QP)	Antenna:	Horizontal
EUT:	Yoga 3 in 1 Wireless Charging Stand	Temperature:	24.2°C
M/N.:	A31FWCWH	Humidity:	53%RH
Mode:	Wireless Charging 15W+5W+1.5W	Power Rating:	AC 120V/60Hz
Test Engineer:	Karry	Test Time:	2023/9/9

No.	Frequency (MHz)	Reading (dBuV)	Factor (dB/m)	Level (dBuV/m)	Limit (dBuV/m)	Margin (dB)	Det.	Height (cm)	Azimuth (deg)	Remark
1	61.1316	23.50	-5.24	18.26	40.00	-21.74	QP	150.0	360.0	
2	108.2667	23.96	-4.56	19.40	43.50	-24.10	QP	150.0	360.0	
3	124.5690	27.37	-6.30	21.07	43.50	-22.43	QP	150.0	360.0	
4	180.0165	31.27	-8.46	22.81	43.50	-20.69	QP	150.0	360.0	
5	276.1235	28.47	-2.87	25.60	46.00	-20.40	QP	150.0	360.0	
6 *	375.9385	27.87	0.07	27.94	46.00	-18.06	QP	150.0	360.0	

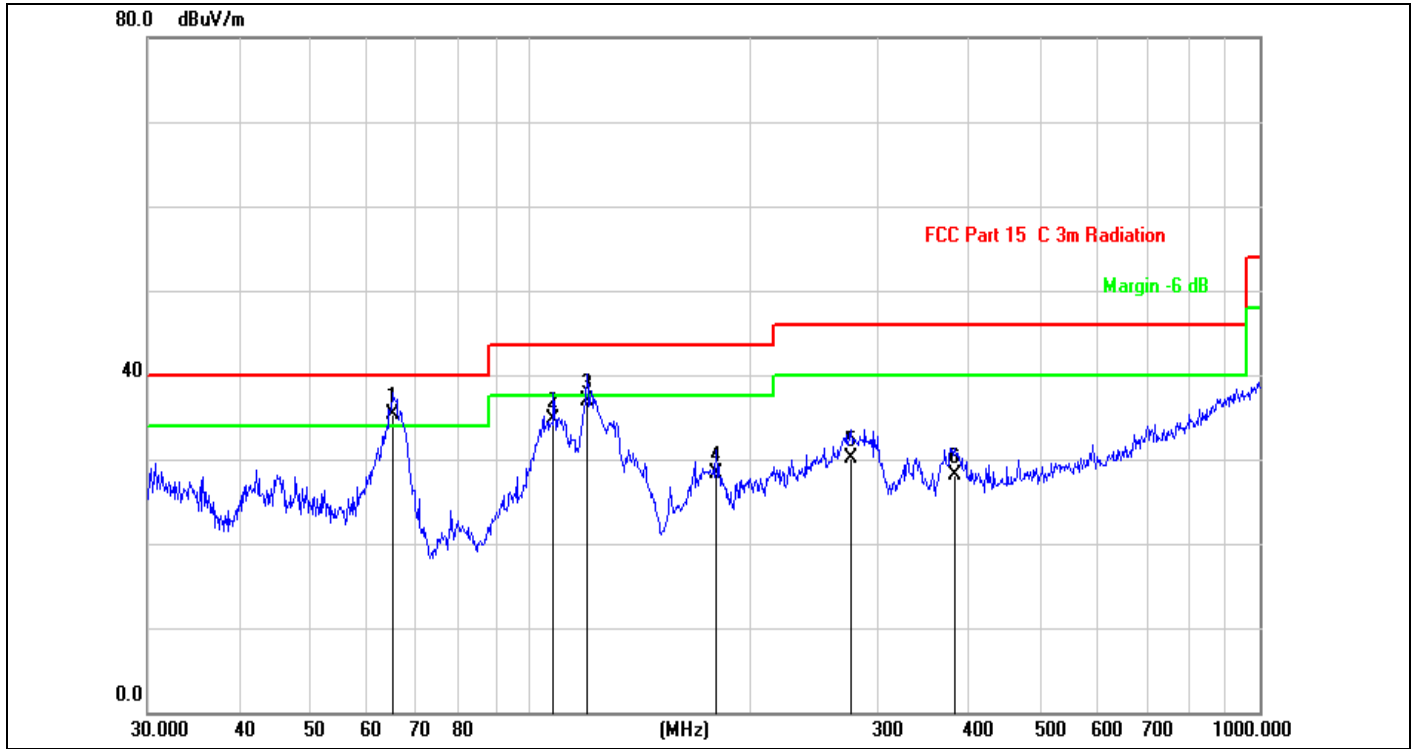

Limit:	FCC Part 15C 3m Radiation(QP)	Antenna:	Vertical
EUT:	Yoga 3 in 1 Wireless Charging Stand	Temperature:	24.2°C
M/N.:	A31FWCWH	Humidity:	53%RH
Mode:	Wireless Charging 15W+5W+1.5W	Power Rating:	AC 120V/60Hz
Test Engineer:	Karry	Test Time:	2023/9/9

No.	Frequency (MHz)	Reading (dBuV)	Factor (dB/m)	Level (dBuV/m)	Limit (dBuV/m)	Margin (dB)	Det.	Height (cm)	Azimuth (deg)	Remark
1 *	65.1145	42.11	-6.81	35.30	40.00	-4.70	QP	150.0	360.0	
2	107.8877	39.37	-4.57	34.80	43.50	-8.70	QP	150.0	360.0	
3	119.8556	42.44	-5.55	36.89	43.50	-6.61	QP	150.0	360.0	
4	180.0165	36.73	-8.46	28.27	43.50	-15.23	QP	150.0	360.0	
5	275.1570	33.08	-2.92	30.16	46.00	-15.84	QP	150.0	360.0	
6	382.5879	27.80	0.25	28.05	46.00	-17.95	QP	150.0	360.0	

6.6 Radiated Measurement Photos

9kHz-30MHz



30MHz-1GHz



7 20db Bandwidth

7.1 20dB Bandwidth Limit

None: for reporting purposed only.

7.2 Test Instruments

Refer a test equipment and calibration data table in this test report.

7.3 Test Procedure

The bandwidth of the fundamental frequency was measured by spectrum analyzer with 1KHz RBW and 3KHz VBW. The 20dB bandwidth is defined as the total spectrum the power of which is higher than peak power minus 20dB.

7.4 Test Setup

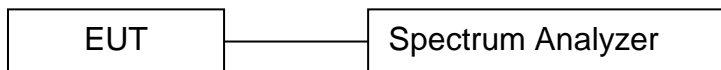

7.5 Test Result

phone charging

Frequency (KHz)	20dB Bandwidth (KHz)	Results
127.7	2.689	PASS

Watch charging

Frequency (KHz)	20dB Bandwidth (KHz)	Results
325.8	2.696	PASS

Earphone charging

Frequency (KHz)	20dB Bandwidth (KHz)	Results
113.7	2.788	PASS

20 dB Bandwidth Test plot
phone charging

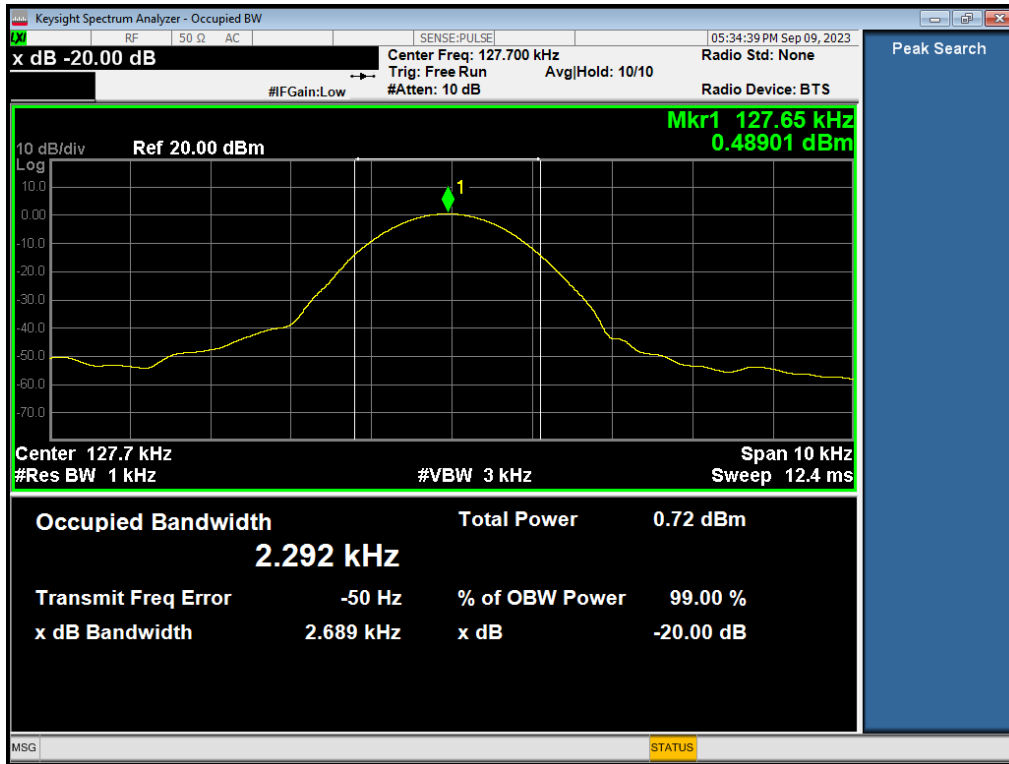

Watch charging

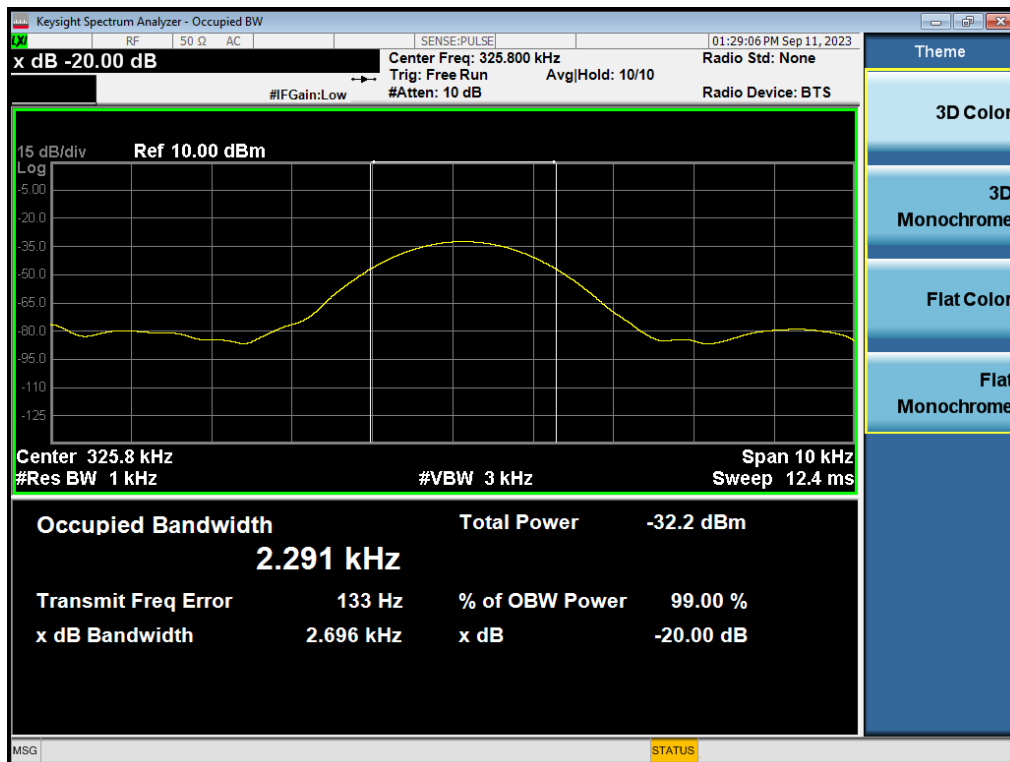

Earphone charging

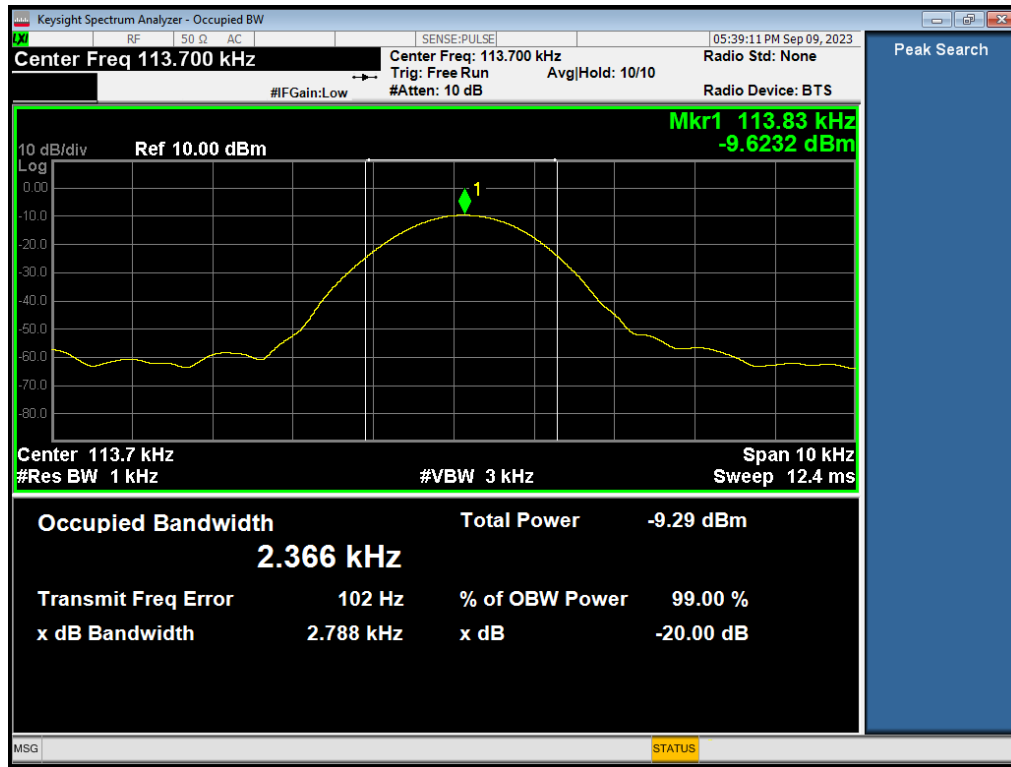

8 Antenna Application

8.1 Antenna requirement

For intentional device, according to FCC 47 CFR Section 15.203, an intentional radiator shall be designed to ensure that no antenna other than that furnished by the responsible party shall be used with the device.

8.2 Result

The EUT's antenna, permanent attached antenna, used an Induction coil and integrated on PCB, The antenna's gain meets the requirement.

APPENDIX (Photos of EUT)

External-1



External-2



External-3



External-4



External-5



External-6



External-7

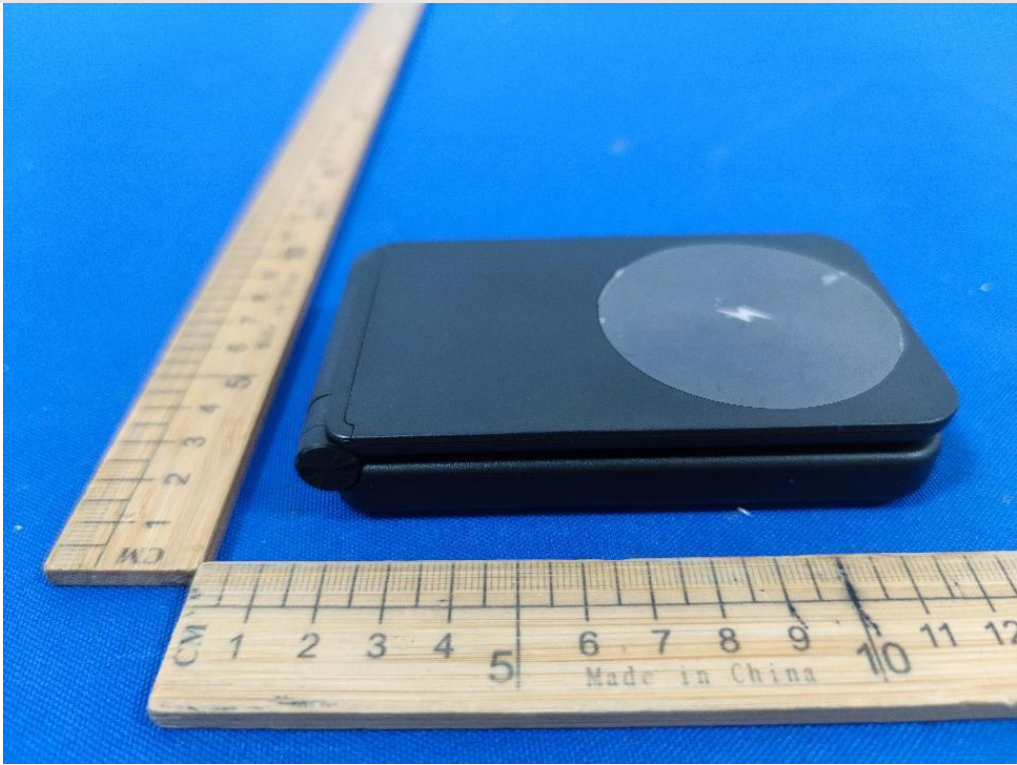

External-8



External-9



External-10



External-11



External-12



External-13



External-14



External-15



External-16



Internal-1



Internal-2

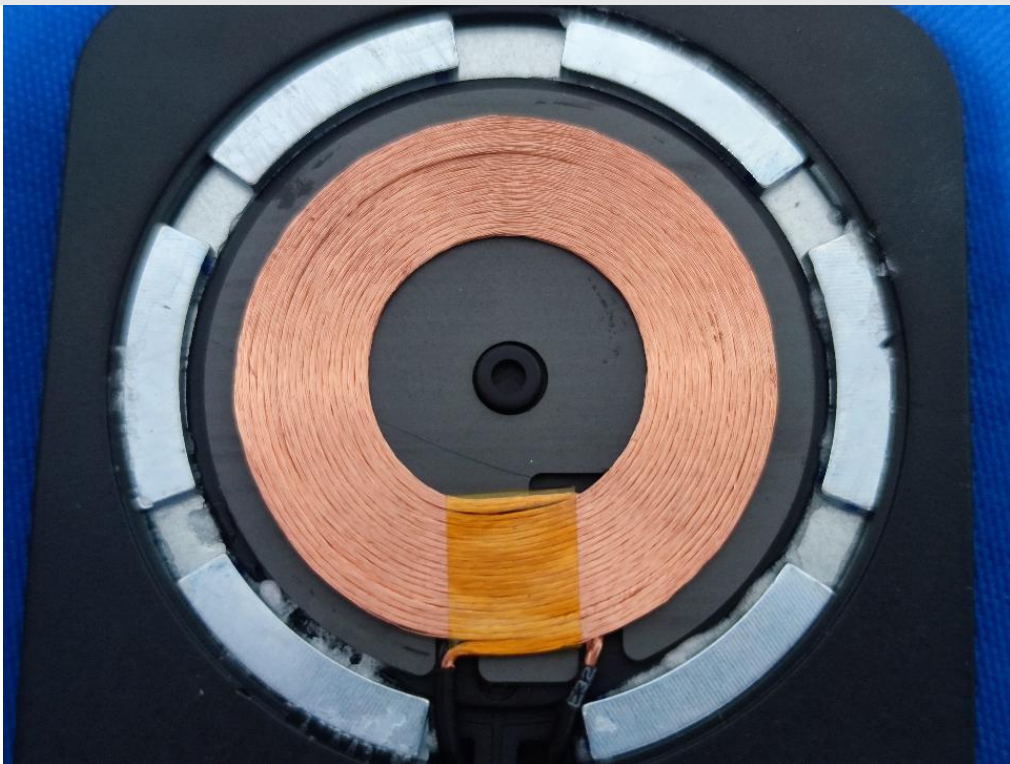

Internal-3



Internal-4

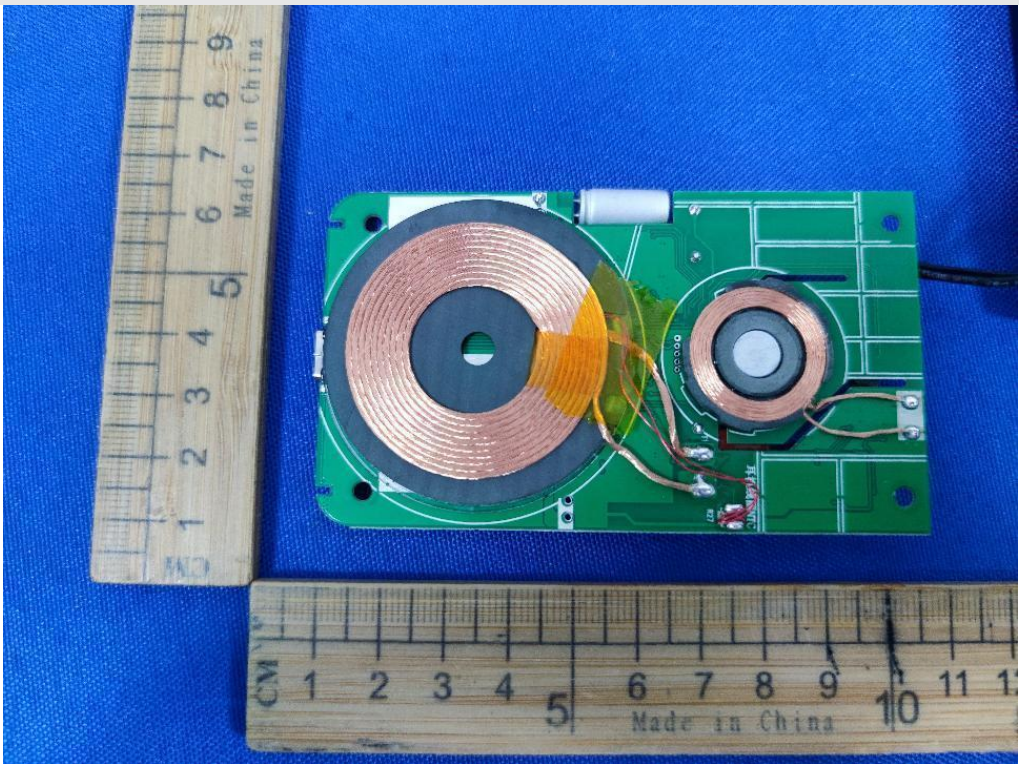

Internal-5

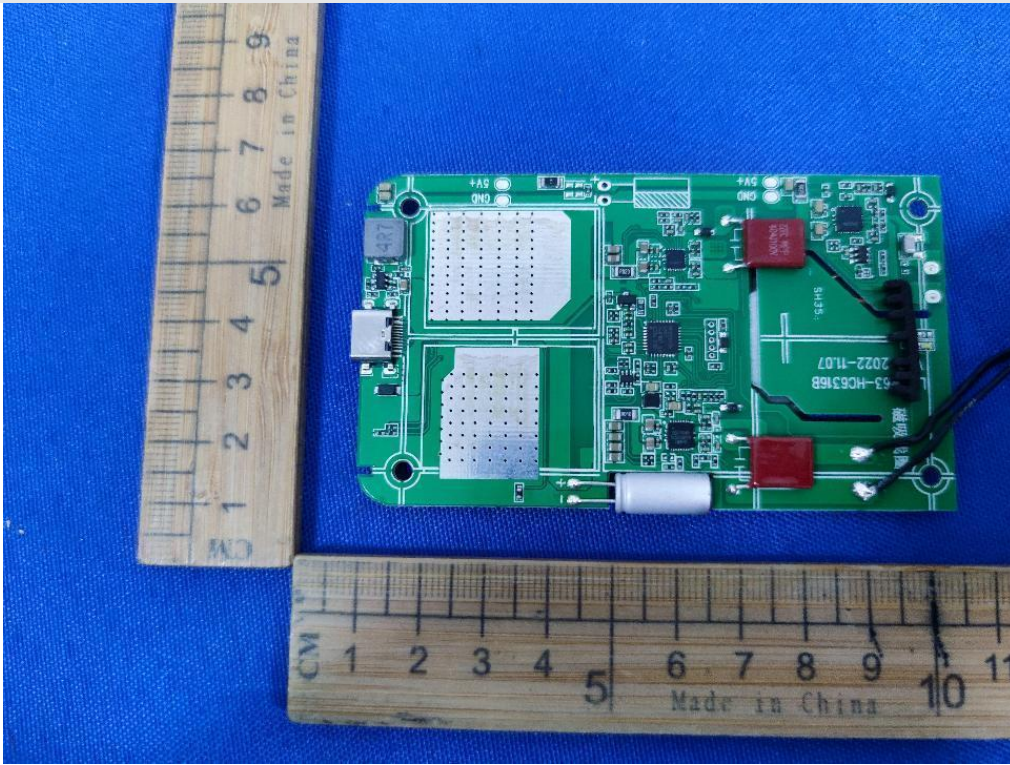

--- END OF REPORT---