

承 認 書



SPECIFICATION FOR APPROVAL

客 戶:
CUSTOMER: _____

客 戶 料 號:
CUST P/N: **10.0110.1207**

松 島 料 號:
FINE P/N: **手表发射线圈
Watch transmitting coil 6.8UH 0.08*24P*11TS**

產 品 型 號:
DESC: _____

日 期:
DATE: **2021/08/18**

版 本:
Version: **A.0**

擬 制 PREPARED BY	審 核 CHECKED BY	批 准 APPROVED BY	客 戶 承 認 CUSTOMER APPROVE
HUANG YANMING	NING YUANAN	HUANG JINHUA	

SPECIFICATION

產品型號: DESC	苹果发射线圈 Apple transmitter coil 15*21.5-6.8UH	版本 Rev: A.0	客戶 CUST: 客户料号 CUST P/N:	XXX
---------------	--	----------------	----------------------------	-----

一、尺寸 DIMENSION:(mm)

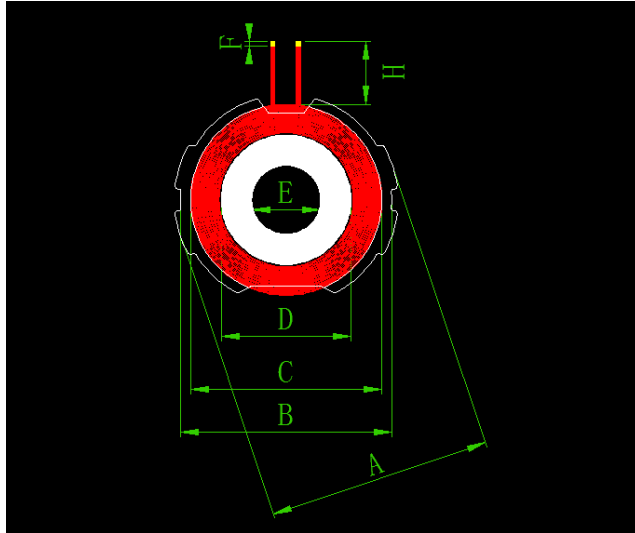

A	25±1
B	23.6±0.5
C	21.5±0.5
D	14.5±0.3
E	7.7±0.05
F	3±2
H	20±2

注:

- 1.交叉出线;
- 2.出线位置缠 mm(ref)宽度高温胶纸 Ts;
- 3.线圈贴圆形硬磁片两端带缺口,磁片尺寸 25±1mm,内孔 7.7mm,厚度为 2.8±0.2mm。

Note:

1. Cross outlet;
2. Wrap the outlet position with mm (ref) high-temperature tape Ts;
3. The coil is attached to a circular hard magnetic piece with notches at both ends. The size of the magnetic piece is 25±1mm, the inner hole is 7.7mm, and the thickness is 2.8±0.2mm.

二、原理图 SCHEMATIC DIAGRAM:

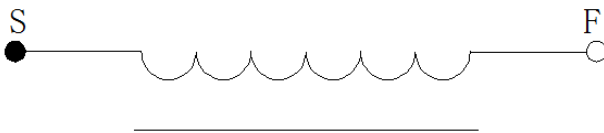

三、绕线参数 Winding Specification:

序号 NO.	端子 TERMINAL		线径 WIRE	圈数 Turns	绕线方向 Winding Direction
1	S	F	漆包线 Enameled wire 0.08*24P	11Ts	CCW

四、电气特性 ELECTRICAL CHARACTERISTICS:

温度 TEMPERATURE:25±10℃, 湿度 RELATIVE HUMIDITY:65±20%

序号 NO.	项目 ITEM	端子 TERMINAL	标准 SPECIFICATION	测试条件 TEST FREQUENCY	测试仪器 TEST EQUIPMENTS
1	IND.	S-F	3.1uH ±20%单独线圈 single-coil	100KHz/1.0V	LCZ METER 1062B
2	IND.	S-F	6.8uH ±20%单独线圈 single-coil	100KHz/1.0V	LCZ METER 1062B
3	DCR	S-F	≤110mΩ	100KHz/1.0V	LCZ METER 502B
4	Q	S-F	≤32	100KHz/1.0V	LCZ METER 502B

编制/日期 PREPARED BY/DATE	审核/日期 CHECKED BY/DATE
HUANG YANMING 2021/08/18	HUANG JINHUA 2021/08/18