

# RF TEST REPORT

**FCC ID: 2ATAZ-MWI3000W4P**

According to

**47 CFR FCC Part 15, Subpart C(Section 15.247)**

**ANSI C63.10:2013**

Product description : Intelligent Wireless Access Point  
 Model No. : TS-MWI3000W4P, 1LAN-WAP-6W  
 Trade Mark :   
 Product No. : POC230817006-S001  
 Applicant : Technity Solutions Inc.  
 500 Cochrane Drive, Unit 1, Markham, ON, Canada, L3R 8E2  
 Receipt date : 2023.08.17  
 Test date : 2023.08.17~2023.09.10  
 Issued Date : 2023.09.13

Prepared By:	Checked By:	Approved By:	
Black ding	Tim zhang	Misue Su	
<i>Black Ding</i>	<i>Tim.zhang</i>	<i>Misue Su</i>	

**Note:** This report shall not be reproduced except in full, without the written approval of Shenzhen Haiyun Standard Technical Co., Ltd. This document may be altered or revised by Shenzhen Haiyun Standard Technical Co., Ltd. Personnel only, and shall be noted in the revision section of the document. The test results of this report relate only to the tested sample identified in this report.

# Table of Contents

<b>History of this test report</b> .....	<b>4</b>
<b>1. General Information</b> .....	<b>5</b>
1.1 Applicant.....	5
1.2 Manufacturer.....	5
1.3 Basic Description of Equipment Under Test.....	5
1.4 Transmit Operating Mode .....	6
<b>2. Summary of Test Results</b> .....	<b>7</b>
2.1 Summary of Test Items .....	7
2.2 Application of Standard.....	7
2.3 Test Instruments .....	8
2.4 Test Mode .....	9
2.5 Test Condition .....	10
2.6 Duty Cycle of Test Signal .....	10
2.7 Measurement Uncertainty.....	14
2.8 Test Location.....	14
2.9 Description of Support Units .....	14
2.10 Deviation from Standards .....	14
<b>3. Test Procedure And Results</b> .....	<b>15</b>
3.1 AC Power Line Conducted Emission .....	15
3.1.1 Limit.....	15
3.1.2 Test Procedure.....	15
3.1.3 Test Setup.....	15
3.1.4 Test Result.....	16
3.2 Radiated Emission and Band Edge .....	18
3.2.1 Limit.....	18
3.2.2 Test Procedure.....	18
3.2.3 Test Setup.....	19
3.2.4 Test Result.....	21
3.3 Spurious Emission at Antenna Port.....	53
3.3.1 Limit.....	53

---

3.3.2	Test Procedure.....	53
3.3.3	Test Setup.....	54
3.3.4	The Result .....	55
3.4	6dB Bandwidth.....	121
3.4.1	Limit.....	121
3.4.2	Test Procedure.....	121
3.4.3	Test Setup.....	121
3.4.4	Test Result.....	122
3.5	Maximum conducted output power .....	160
3.5.1	Limit.....	160
3.5.2	Test Procedure.....	160
3.5.3	Test Setup.....	160
3.5.4	Table of Parameters of Text Software Setting .....	161
3.5.5	The Result .....	162
3.6	Power Spectral Density.....	166
3.6.1	Limit.....	166
3.6.2	Test Procedure.....	166
3.6.3	Test Setup.....	166
3.6.4	The Result .....	167

## History of this test report

Original Report Issue Date: 2023.09.13

- No additional attachment
- Additional attachments were issued following record

Attachment No.	Issue Date	Description

## 1. General Information

### 1.1 Applicant

Technity Solutions Inc.

500 Cochrane Drive, Unit 1, Markham, ON, Canada, L3R 8E2

### 1.2 Manufacturer

Technity Solutions Inc.

500 Cochrane Drive, Unit 1, Markham, ON, Canada, L3R 8E2

### 1.3 Basic Description of Equipment Under Test

Items	Description	
Equipment Name	Intelligent Wireless Access Point	
Model No.	TS-MWI3000W4P, 1LAN-WAP-6W	
Test model	TS-MWI3000W4P	
Model difference	Only model name is different	
Trade Mark		
Power Supply	DC 57V from adapter	
Operate temperature	0°C-60°C	
EUT Stage	○ Product Unit	● Final-Sample
Operating Band and Conducted Output Power (Max power)	2400MHz ~ 2483.5MHz	●IEEE 802.11G: 18.92dBm
Product Type	IEEE 802.11b: WLAN (MIMO) IEEE 802.11g: WLAN (MIMO) IEEE 802.11n: WLAN (MIMO) IEEE 802.11ax: WLAN (MIMO)	
Nominal Bandwidth	20MHz / 40MHz	
Modulation	IEEE 802.11b: DSSS (DBPSK / DQPSK / CCK) IEEE 802.11g: OFDM (BPSK / QPSK / 16QAM / 64QAM) IEEE 802.11n: OFDM (BPSK / QPSK / 16QAM / 64QAM) IEEE 802.11ax: OFDMA (BPSK / QPSK / 16QAM / 64QAM)	
Data Rate (Mbps)	IEEE 802.11b mode: (1/2/5.5/11) IEEE 802.11g mode: (6/9/12/18/24/36/48/54) IEEE 802.11n mode: up to 300 IEEE 802.11ax mode: up to 573.6	
Antenna gain	Ant1: 3.76dBi, Ant2: 3.98dBi	
Antenna type	PCB antenna	

Eleven channels are provided for 802.11b, 802.11g, 802.11n (20MHz), 802.11ax (20MHz):

Frequency Band	Channel No.	Frequency	Channel No.	Frequency
2400MHz ~ 2483.5 MHz	01	2412MHz	07	2442MHz
	02	2417MHz	08	2447MHz
	03	2422MHz	09	2452MHz
	04	2427MHz	10	2457MHz
	05	2432MHz	11	2462MHz
	06	2437MHz	/	/

Seven channels are provided for 802.11n (40MHz), 802.11ax (40MHz):

Frequency Band	Channel No.	Frequency	Channel No.	Frequency
2400MHz ~ 2483.5 MHz	03	2422 MHz	07	2442MHz
	04	2427MHz	08	2447MHz
	05	2432MHz	09	2452MHz
	06	2437MHz	/	/

Note: For 802.11ax mode only support full RU mode.

## 1.4 Transmit Operating Mode

Transmit Operating Mode				Transmit Multiple Antennas					
<input type="radio"/>	Operating mode 1 (single antenna)			<input type="radio"/>	1TX				
<input type="radio"/>	Operating mode 2 (multiple antenna, no beamforming)			<input type="radio"/>	2TX	<input type="radio"/>	3TX	<input type="radio"/>	4TX
<input checked="" type="radio"/>	Operating mode 3 (multiple antenna, with beamforming)			<input checked="" type="radio"/>	2TX	<input type="radio"/>	3TX	<input type="radio"/>	4TX
<input checked="" type="radio"/>	802.11b	Operating mode	<input type="radio"/>	1TX	<input checked="" type="radio"/>	2TX	<input type="radio"/>	3TX	
<input checked="" type="radio"/>	802.11g	Operating mode	<input type="radio"/>	1TX	<input checked="" type="radio"/>	2TX	<input type="radio"/>	3TX	
<input checked="" type="radio"/>	802.11n(20MHz)	Operating mode	<input type="radio"/>	1TX	<input checked="" type="radio"/>	2TX	<input type="radio"/>	3TX	
<input checked="" type="radio"/>	802.11n(40MHz)	Operating mode	<input type="radio"/>	1TX	<input checked="" type="radio"/>	2TX	<input type="radio"/>	3TX	
<input checked="" type="radio"/>	802.11ax(20MHz)	Operating mode	<input type="radio"/>	1TX	<input checked="" type="radio"/>	2TX	<input type="radio"/>	3TX	
<input checked="" type="radio"/>	802.11ax(40MHz)	Operating mode	<input type="radio"/>	1TX	<input checked="" type="radio"/>	2TX	<input type="radio"/>	3TX	
Beam forming gain: 2.5dB									

## 2. Summary of Test Results

### 2.1 Summary of Test Items

47 CFR FCC Part 15, Subpart C (Section 15.247)			
Test item	FCC Clause	Results	Remarks
AC Power Conducted Emission	15.207	Pass	Meet the requirement of the limit
Radiated Emission and Band Edge Measurement	15.205/15.209 /15.247(d)	Pass	Meet the requirement of the limit
Spurious Emission at Antenna Port	15.247(d)	Pass	Meet the requirement of the limit
6dB Bandwidth	15.247(a)(2)	Pass	Meet the requirement of the limit
Maximum Conducted Power	15.247(b)	Pass	Meet the requirement of the limit
Power Spectral Density	15.247(e)	Pass	Meet the requirement of the limit
Antenna Requirements	15.203	Compliance	Note
Note: The EUT has 2 PCB antennas arrangement which was permanently attached.			

### 2.2 Application of Standard

47 CFR FCC Part 15, Subpart C (Section 15.247)

KDB 558074 D01 15.247 Meas Guidance v05r02

KDB 662911 D01 Multiple Transmitter Output v02r01

ANSI C63.10:2013

## 2.3 Test Instruments

Radiated Emissions						
No.	Equipment	Manufacturer	Type No.	Serial No.	Cal. date (yyyy/mm/dd)	Cal. Due date (yyyy/mm/dd)
1	Test receiver	Rohde&Schwarz	ESU	100184	2023/5/3	2024/5/2
2	Horn Antenna	Schwarzbeck	BBHA 9120 D	9120D-127 3	2023/4/23	2024/4/22
3	Low frequency amplifier	Unknown	LNA 0920N	2014	2023/5/3	2024/5/2
4	High frequency amplifier	Schwarzbeck	BBV 9718	284	2023/5/3	2024/5/2
5	Loop Antenna	Schwarzbeck	FMZB1519 B	00029	2022/7/4	2025/7/3
6	Log periodic antenna	Schwarzbeck	VULB 9168	1151	2023/4/23	2024/4/22
7	Horn Antenna	Schwarzbeck	BBHA 9120 D	9120D-127 3	2022/5/5	2025/5/4
8	Horn Antenna	Schwarzbeck	BBHA 9170	9170#685	2022/7/4	2025/7/3
9	Temp&Humidity Recorder	Meideshi	JR900	/	2023/5/3	2024/5/2
10	RF cable(966 chamber)9kHz-1 GHz	Unknown	Unknown	Unknown	2023/5/3	2024/5/2
11	RF cable(966 chamber)1GHz-18GHz	Unknown	Unknown	Unknown	2023/5/3	2024/5/2
12	RF cable(966 chamber)18GHz-40GHz	Unknown	Unknown	Unknown	2023/5/3	2024/5/2
13	Test software	Farad Technology Co., Ltd	EZ-EMC	/	/	/
Conducted Emission						
1	Test receiver	Rohde&Schwarz	ESCI	100718	2023/5/3	2024/5/2
2	LISN	Rohde&Schwarz	ENV216	100075	2023/5/3	2024/5/2
3	Pulse limiter	Rohde&Schwarz	ESH3-Z2	102299	2023/5/3	2024/5/2
4	RF cable (9kHz-30MHz)	Unknown	Unknown	Unknown	2023/5/3	2024/5/2
5	Test software	Farad Technology Co., Ltd	EZ-EMC	/	/	/
RF Conducted Emission						
1	MXA Signal Analyzer	Keysight	N9021B	MY600801 69	2023/4/23	2024/4/22
2	RF Control Unit	dsusoft	JS0806-2	21G806044 9	2023/4/23	2024/4/22
3	power supply unit	dsusoft	JS0806-4A DC	N/A	2023/4/23	2024/4/22
4	VXG Signal Generator	Keysight	M9384B	MY612707 87	2023/4/23	2024/4/22
5	EXG Analog Signal Generator	Keysight	N5173B	MY591012 82	2023/4/23	2024/4/22
6	Test software	dsusoft	JS1120-3	/	/	/



## 2.4 Test Mode

Test Items	Mode	Data Rate	Channel
AC Power Conducted Emission	802.11G-CDD	6Mbps	06
Radiated Emission and Band Edge Measurement	802.11B-CDD	1Mbps	01/06/11
	802.11G-CDD	6Mbps	01/06/11
	802.11n(20MHz)	MCS0	01/06/11
	802.11n(40MHz)	MCS0	03/06/09
	802.11ax(20MHz)	MCS0	01/06/11
	802.11ax(40MHz)	MCS0	03/06/09
Spurious Emission at Antenna Port	802.11B-CDD	1Mbps	01/06/11
	802.11G-CDD	6Mbps	01/06/11
	802.11n(20MHz)	MCS0	01/06/11
	802.11n(40MHz)	MCS0	03/06/09
	802.11ax(20MHz)	MCS0	01/06/11
	802.11ax(40MHz)	MCS0	03/06/09
6dB Bandwidth	802.11B-CDD	1Mbps	01/06/11
	802.11G-CDD	6Mbps	01/06/11
	802.11n(20MHz)	MCS0	01/06/11
	802.11n(40MHz)	MCS0	03/06/09
	802.11ax(20MHz)	MCS0	01/06/11
	802.11ax(40MHz)	MCS0	03/06/09
Maximum Conducted Power	802.11B-CDD	1Mbps	01/06/11
	802.11G-CDD	6Mbps	01/06/11
	802.11n(20MHz)	MCS0	01/06/11
	802.11n(40MHz)	MCS0	03/06/09
	802.11ax(20MHz)	MCS0	01/06/11
	802.11ax(40MHz)	MCS0	03/06/09
Power Spectral Density	802.11B-CDD	1Mbps	01/06/11
	802.11G-CDD	6Mbps	01/06/11
	802.11n(20MHz)	MCS0	01/06/11
	802.11n(40MHz)	MCS0	03/06/09
	802.11ax(20MHz)	MCS0	01/06/11
	802.11ax(40MHz)	MCS0	03/06/09

## 2.5 Test Condition

Applicable to	Environmental conditions	Input Power	Tested by
AC Power Conducted Emission	24.3°C, 51% RH	AC 120V/60Hz	Albert Fan
Radiated Emission and Band Edge Measurement	24.2°C, 55% RH	AC 120V/60Hz	Albert Fan
Spurious Emission at Antenna Port	24.2°C, 52% RH	AC 120V/60Hz	Jason Huang
6dB Bandwidth	24.2°C, 52% RH	AC 120V/60Hz	Jason Huang
Maximum Conducted Power	24.2°C, 52% RH	AC 120V/60Hz	Jason Huang
Power Spectral Density	24.2°C, 52% RH	AC 120V/60Hz	Jason Huang

Note: Adapter supply voltage AC 120V/60Hz.

The applicant declare the operating environment of EUT as below:

Normal conditions: AC 120V/60Hz, 0~60°C

## 2.6 Duty Cycle of Test Signal

If duty cycle is  $\geq 98\%$ , duty factor is not required.

If duty cycle is  $< 98\%$ , duty factor shall be considered.

All the duty factor of other test mode have been considered.

Test Mode	Frequency[MHz]	Transmission Duration [ms]	Transmission Period [ms]	Duty Cycle[%]
11B-CDD	2412	8.41	9.06	92.83
11G-CDD	2412	0.13	0.23	56.52
11N20MIMO	2412	0.14	0.24	58.33
11N40MIMO	2422	0.12	0.22	54.55
11AX20MIMO	2412	0.33	0.36	91.67
11AX40MIMO	2422	0.31	0.34	91.18

11B-CDD\_2412

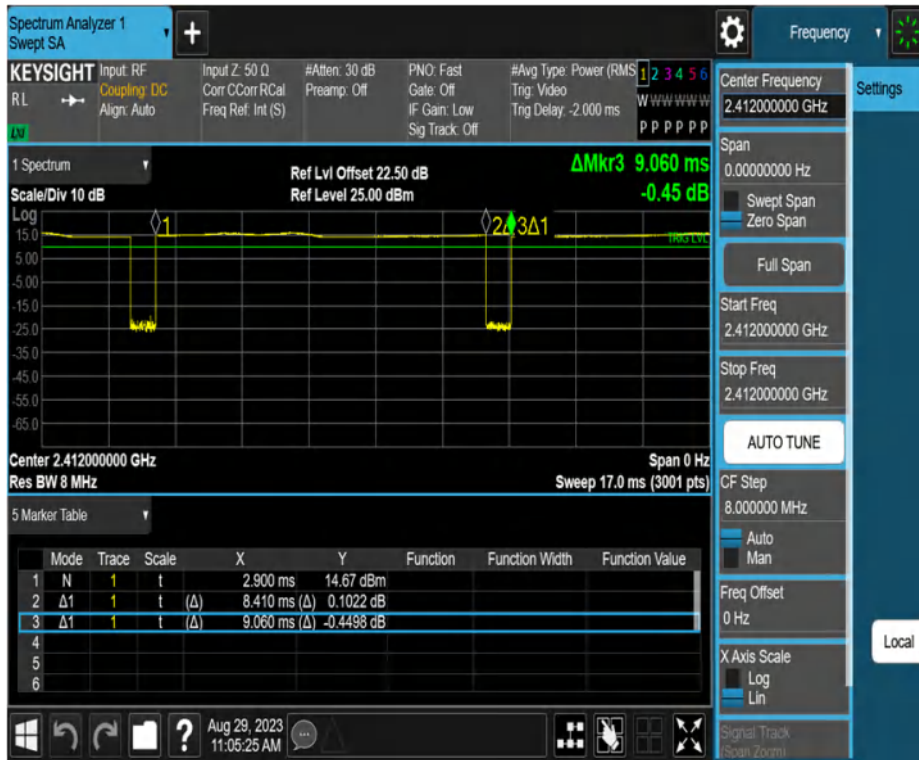

11G-CDD\_2412

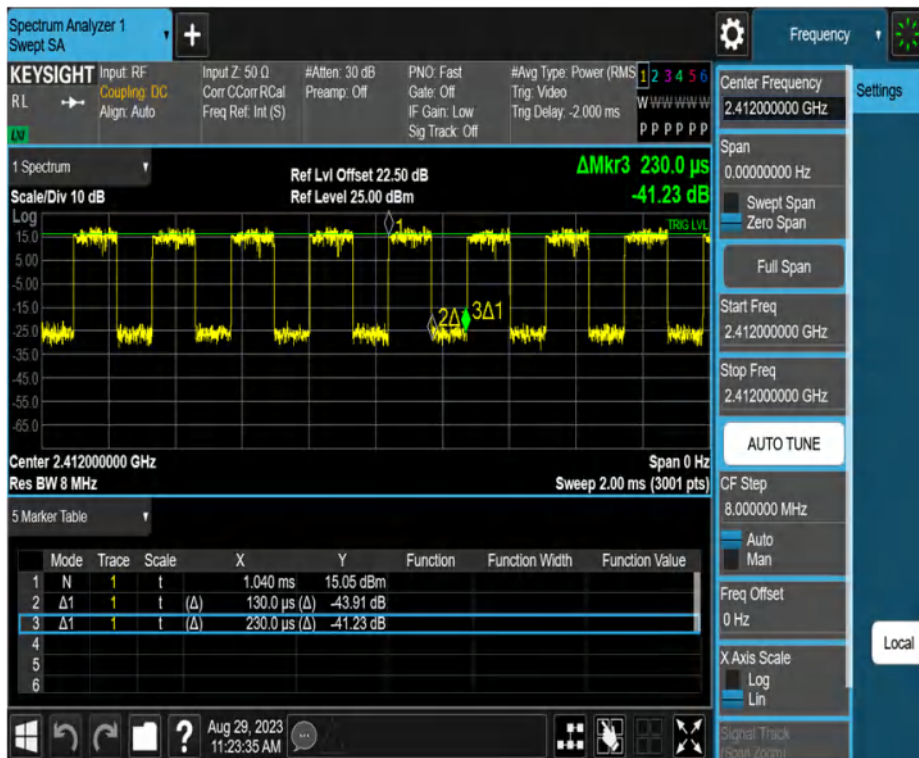

11N20MIMO\_2412

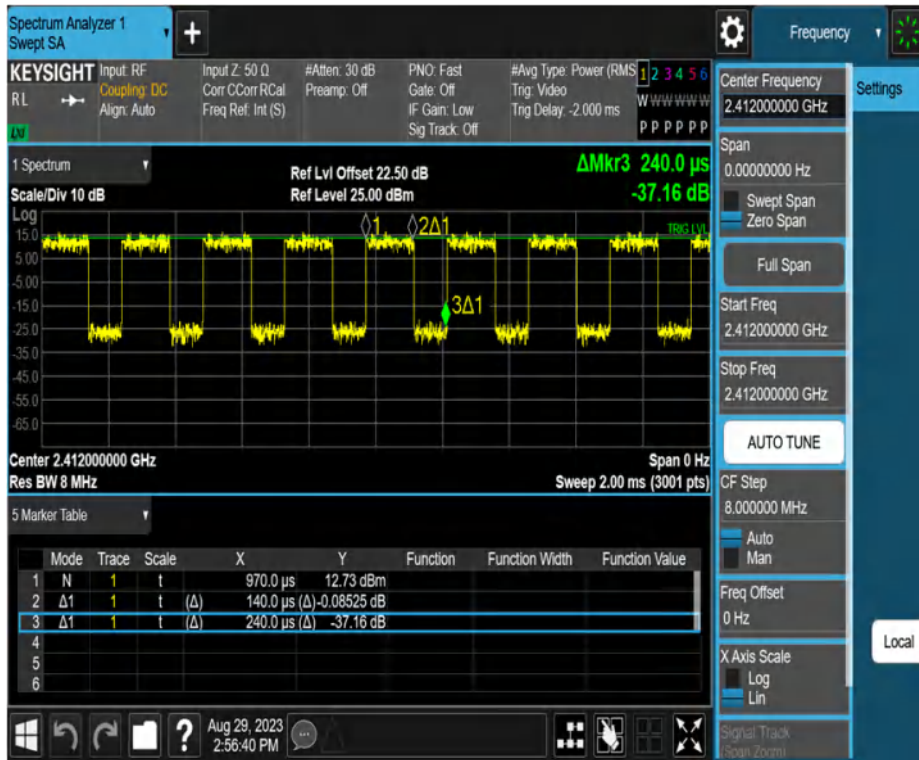

11N40MIMO\_2422

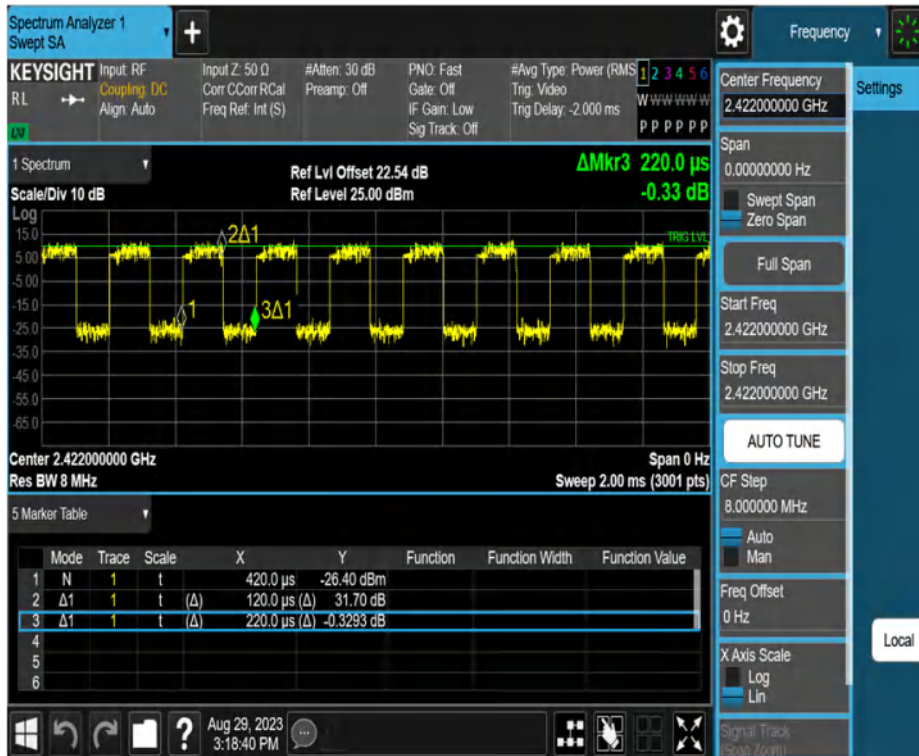

11AX20MIMO\_2412

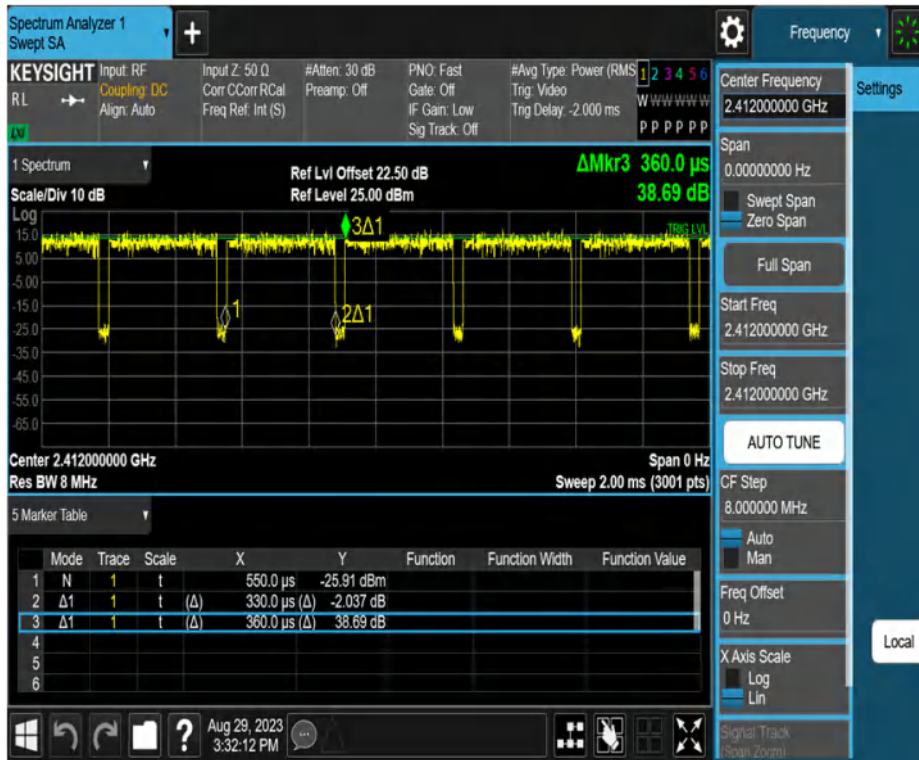

11AX40MIMO\_2422

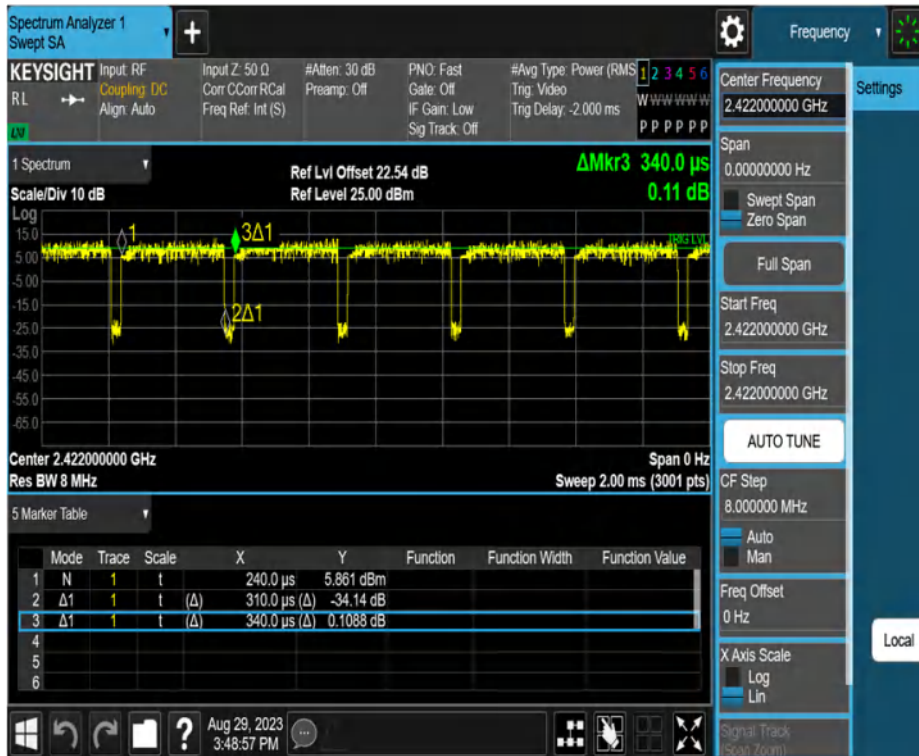

## 2.7 Measurement Uncertainty

Where relevant, the following measurement uncertainty levels have been estimated for tests performed on the EUT.

This uncertainty represents an expanded uncertainty expressed at approximately the 95% confidence level using a coverage factor of  $k=2$ .

Uncertainty	
Parameter	Uncertainty
Occupied Channel Bandwidth	$\pm 143.88\text{kHz}$
Power Spectral Density	$\pm 0.743\text{dB}$
Conducted Spurious Emission	$\pm 1.328\text{dB}$
RF power conducted	$\pm 0.384\text{dB}$
Conducted emission(9kHz~30MHz) AC main	$\pm 2.72\text{dB}$
Radiated emission(9kHz~30MHz)	$\pm 2.66\text{dB}$
Radiated emission (30MHz~1GHz)	$\pm 4.62\text{dB}$
Radiated emission (1GHz~18GHz)	$\pm 4.86\text{dB}$
Radiated emission (18GHz~40GHz)	$\pm 3.80\text{dB}$

## 2.8 Test Location

Company:	Shenzhen Haiyun Standard Technical CO., Ltd.
Address:	No. 110-113, 115, 116, Block B, Jinyuan Business Building, Bao'an District, Shenzhen, China
CNAS Registration Number:	CNAS L18252
CAB identifier	CN0145
A2LA Certificate Number	6823.01
Telephone:	0755-26024411

## 2.9 Description of Support Units

No.	Equipment	Manufacturer	Model	Series No
1	Power adapter	Ruijie	RG-DC4805-BA	/
2	Microcomputer	TY510S-07IAB	LENOVO	/
3	Notebook	L450	Think	/

## 2.10 Deviation from Standards

None

### 3. Test Procedure And Results

#### 3.1 AC Power Line Conducted Emission

##### 3.1.1 Limit

Frequency	Maximum RF Line Voltage	
	Quasi-Peak Level dB( $\mu$ V)	Average Level dB( $\mu$ V)
150kHz ~ 500kHz	66 ~ 56*	56 ~ 46*
500kHz ~ 5MHz	56	46
5MHz ~ 30MHz	60	50

Notes: 1. \* Decreasing linearly with logarithm of frequency.

2. The lower limit shall apply at the transition frequencies.

##### 3.1.2 Test Procedure

Test Method	
<input checked="" type="radio"/> Conducted Measurement	<input type="radio"/> Radiated Measurement
Test Channels	
<input type="radio"/> Lowest, Middle and Highest Channel	<input type="radio"/> Lowest and Highest Channel
Environmental conditions	
<input checked="" type="radio"/> Normal	<input type="radio"/> Normal and Extreme
Note: <input checked="" type="radio"/> : Test <input type="radio"/> : No Test	

- The EUT was placed 0.4 meters from the conducting wall of the shielded room with EUT being connected to the power mains through a line impedance stabilization network (LISN). Other support units were connected to the power mains through another LISN. The two LISNs provide 50 ohm/ 50uH of coupling impedance for the measuring instrument.
- Both lines of the power mains connected to the EUT were checked for maximum conducted interference.
- The frequency range from 150kHz to 30MHz was searched. Emission levels under (Limit - 20dB) was not recorded.

##### 3.1.3 Test Setup

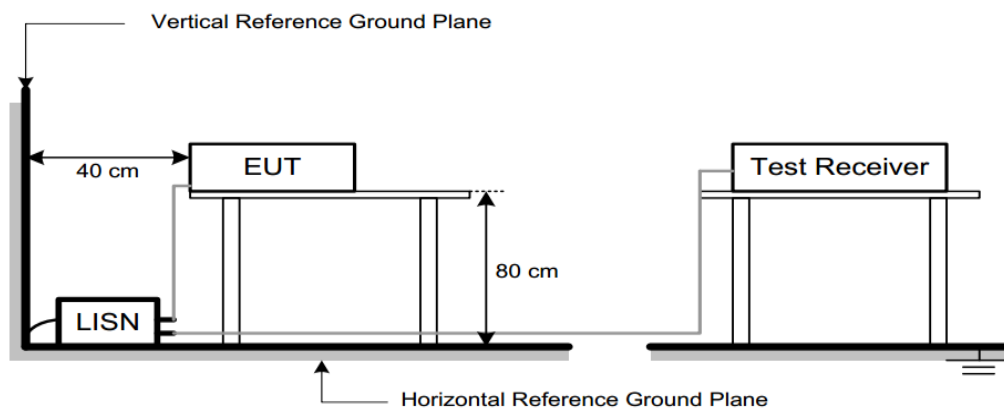

### 3.1.4 Test Result

**Note:**

1. Correct Factor = LISN Factor + Cable Loss + Pulse Limiter Factor, the value was added to Original Receiver Reading by the software automatically.
2. Measurement = Reading + Correct Factor.
3. Over = Measurement – Limit

We only recorded the data of the worst mode. Please see the following:

150kHz~30MHz	Worst Case Operating Mode: 11G-CDD Channel 1
--------------	--

Line

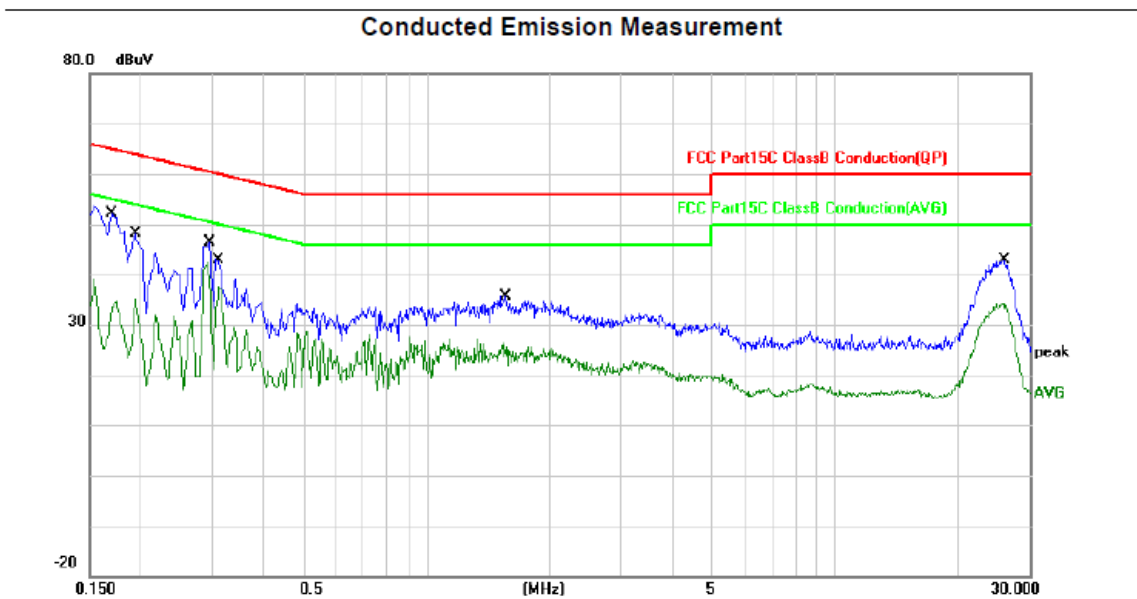

No.	Mk.	Freq.	Reading Level	Correct Factor	Measurement	Limit	Over	Detector	Comment
		MHz	dBuV	dB	dBuV	dBuV	dB		
1		0.1700	30.89	19.88	50.77	64.96	-14.19	QP	
2		0.1700	13.74	19.88	33.62	54.96	-21.34	AVG	
3		0.1940	26.04	19.88	45.92	63.86	-17.94	QP	
4		0.1940	9.80	19.88	29.68	53.86	-24.18	AVG	
5		0.2940	24.72	19.88	44.60	60.41	-15.81	QP	
6	*	0.2940	20.69	19.88	40.57	50.41	-9.84	AVG	
7		0.3116	19.80	19.88	39.68	59.93	-20.25	QP	
8		0.3116	16.69	19.88	36.57	49.93	-13.36	AVG	
9		1.5620	10.95	19.90	30.85	56.00	-25.15	QP	
10		1.5620	4.92	19.90	24.82	46.00	-21.18	AVG	
11		26.0220	17.84	20.12	37.96	60.00	-22.04	QP	
12		26.0220	12.71	20.12	32.83	50.00	-17.17	AVG	



150kHz~30MHz

Worst Case Operating Mode: 11G-CDD Channel 1

Neutral

Conducted Emission Measurement

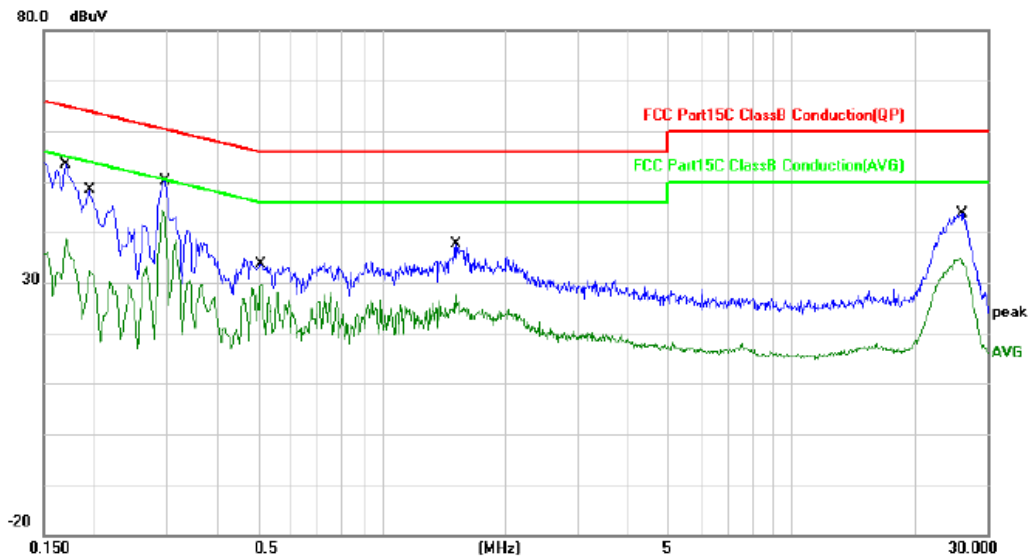

No.	Mk.	Freq.	Reading Level	Correct Factor	Measurement	Limit	Over	Detector	Comment
		MHz	dBuV	dB	dBuV	dBuV	dB		
1		0.1700	31.46	19.88	51.34	64.96	-13.62	QP	
2		0.1700	16.27	19.88	36.15	54.96	-18.81	AVG	
3		0.1940	26.53	19.88	46.41	63.86	-17.45	QP	
4		0.1940	11.27	19.88	31.15	53.86	-22.71	AVG	
5		0.2980	26.01	19.88	45.89	60.30	-14.41	QP	
6	*	0.2980	16.96	19.88	36.84	50.30	-13.46	AVG	
7		0.5100	11.54	19.88	31.42	56.00	-24.58	QP	
8		0.5100	8.31	19.88	28.19	46.00	-17.81	AVG	
9		1.5180	11.47	19.90	31.37	56.00	-24.63	QP	
10		1.5180	5.21	19.90	25.11	46.00	-20.89	AVG	
11		25.9380	18.49	20.12	38.61	60.00	-21.39	QP	
12		25.9380	13.50	20.12	33.62	50.00	-16.38	AVG	

## 3.2 Radiated Emission and Band Edge

### 3.2.1 Limit

Radiated emissions which fall in the restricted bands must comply with the radiated emission limits specified as below table. Other emissions shall be at least 20dB below the highest level of the desired power:

Frequency (MHz)	Distance Meters(m)	Field Strength Limit	
		$\mu\text{V}/\text{m}$	$\text{dB}(\mu\text{V})/\text{m}$
0.009 – 0.49	300	2400/F(kHz)	-
0.490 – 1.705	30	24000/F(kHz)	-
1.705 – 30	30	30	-
30~88	3	100	40.0
88~216	3	150	43.5
216~960	3	200	46.0
960~1000	3	500	54.0
Above 1000	3	74.0 $\text{dB}(\mu\text{V})/\text{m}$ (Peak) 54.0 $\text{dB}(\mu\text{V})/\text{m}$ (Average)	

Note: (1) Emission level  $\text{dB}\mu\text{V} = 20 \log$  Emission level  $\mu\text{V}/\text{m}$

(2) The smaller limit shall apply at the cross point between two frequency bands.

(3) Distance is the distance in meters between the measuring instrument, antenna and the closest point of any part of the device or system.

### 3.2.2 Test Procedure

Test Method	
<input type="radio"/> Conducted Measurement	<input checked="" type="radio"/> Radiated Measurement
Test Channels	
<input checked="" type="radio"/> Lowest, Middle and Highest Channel	<input type="radio"/> Lowest and Highest Channel
Environmental conditions	
<input checked="" type="radio"/> Normal	<input type="radio"/> Normal and Extreme
Note: <input checked="" type="radio"/> : Test <input type="radio"/> : No Test	

- The measuring distance of 3 m shall be used for measurements. The EUT was placed on the top of a rotating table 0.8 meter above the ground at a 3 meter semi-anechoic chamber. The table was rotated 360 degrees to determine the position of the highest radiation.(below 1 GHz)
- The measuring distance of 3 m or 1.5m shall be used for measurements. The EUT was placed on the top of a rotating table 1.5 meter above the ground at a 3 meter semi-anechoic chamber. The table was rotated 360 degrees to determine the position of the highest radiation.(above 1GHz)
- The height of the equipment or of the substitution antenna shall be 0.8m or 1.5m; the height of the test antenna shall vary between 1 m to 4 m. Both horizontal and vertical polarizations of

the antenna are set to make the measurement.

- d) For each suspected emission, the EUT was arranged to its worst case and then the antenna was tuned to heights find the maximum reading (used Bore sight function).
- e) The receiver system was set to peak and average detect function and specified bandwidth with maximum hold mode when the test frequency is above 1 GHz.
- f) The initial step in collecting radiated emission data is a receiver peak detector mode pre-scanning the measurement frequency range. Significant peaks are then marked and then Quasi Peak detector mode re-measured.
- g) All readings are Peak unless otherwise stated QP in column of Note. Peak denotes that the Peak reading compliance with the QP Limits and then QP Mode measurement didn't perform. (below 1 GHz)
- h) All readings are Peak Mode value unless otherwise stated AVG in column of Note. If the Peak Mode Measured value compliance with the Peak Limits and lower than AVG Limits, the EUT shall be deemed to meet both Peak & AVG Limits and then only Peak Mode was measured, but AVG Mode didn't perform. (above 1 GHz)
- i) For the actual test configuration, please refer to the related Item -EUT Test Photos.

### 3.2.3 Test Setup

#### (A) Radiated Emission Test Set-Up Frequency Below 30 MHz

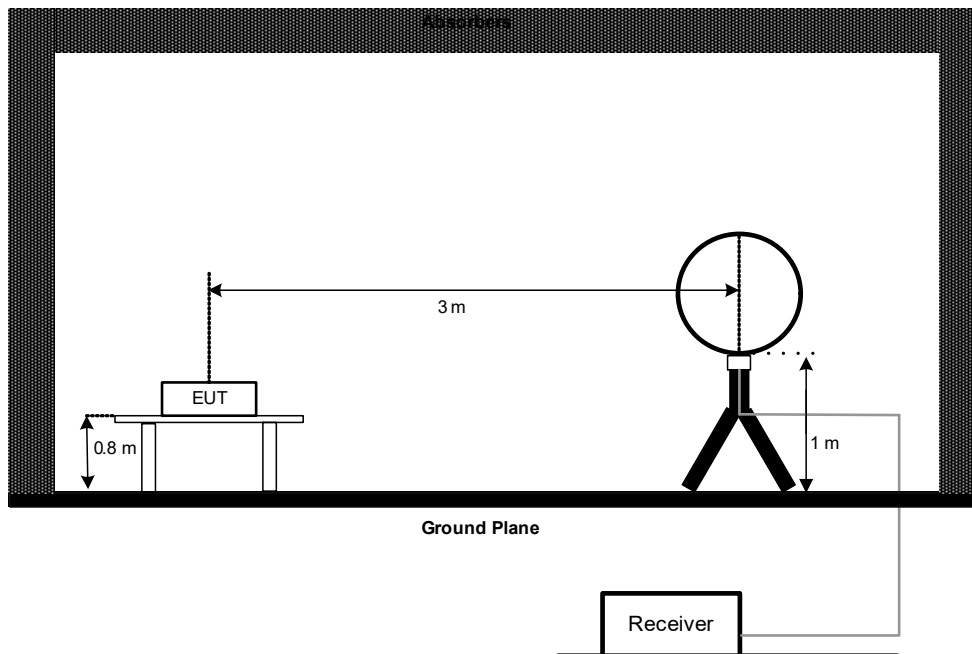

(B) Radiated Emission Test Set-Up Frequency 30 MHz-1000 MHz

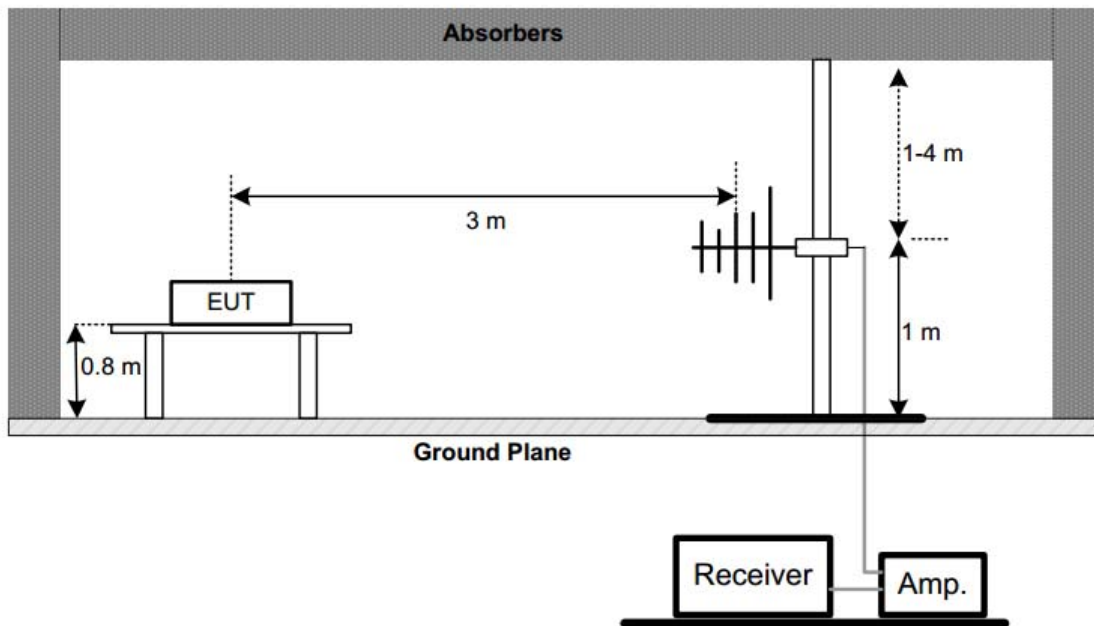

(C) Radiated Emission Test Set-Up Frequency Above 1 GHz

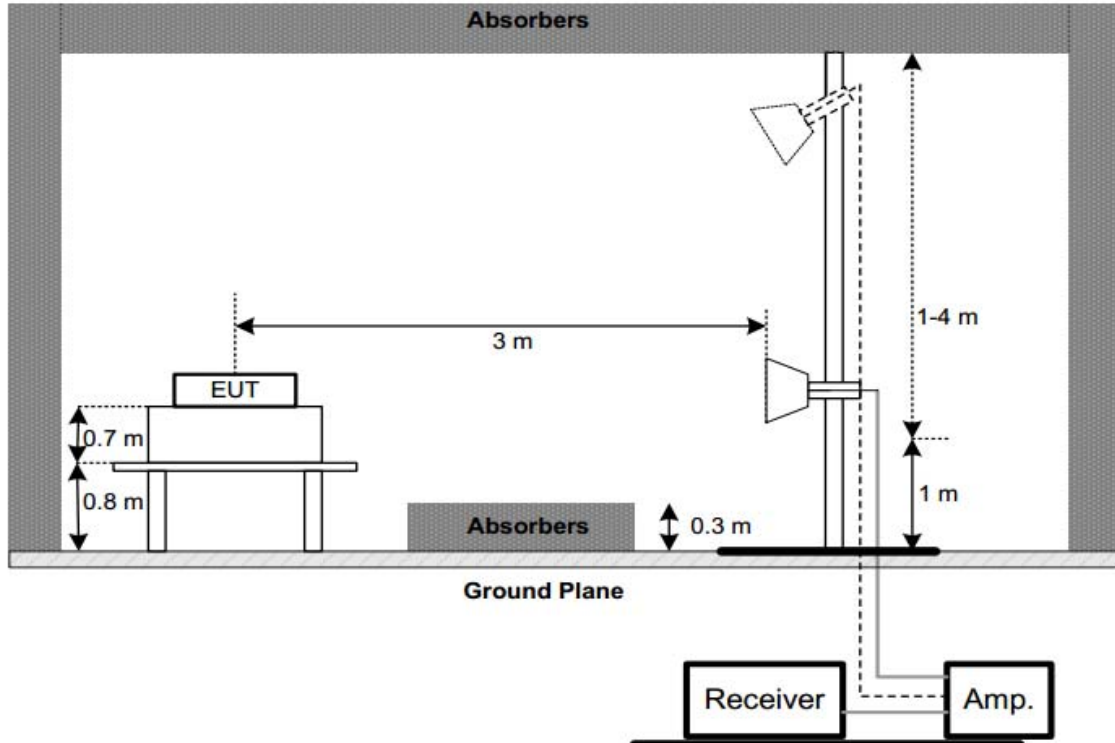

### 3.2.4 Test Result

Pre-scan beamforming mode and non-beamforming mode, worst case for non-beamforming mode is recorded.

#### 1) Radiated emission: 9kHz-30MHz

The low frequency, which started from 9 kHz to 30MHz, was pre-scanned and the result which was 20dB lower than the limit line was not recorded in this report.

#### 2) Radiated emission: 30MHz-1G

**Note:**

1. Measurement = Reading + Correct Factor.
2. Over = Measurement – Limit

We only recorded the data of the worst mode. Please see the following:

Below 1G (30MHz~1GHz)	Worst Case Operating Mode: 11G-CDD Channel 1
-----------------------	--

VERTICAL

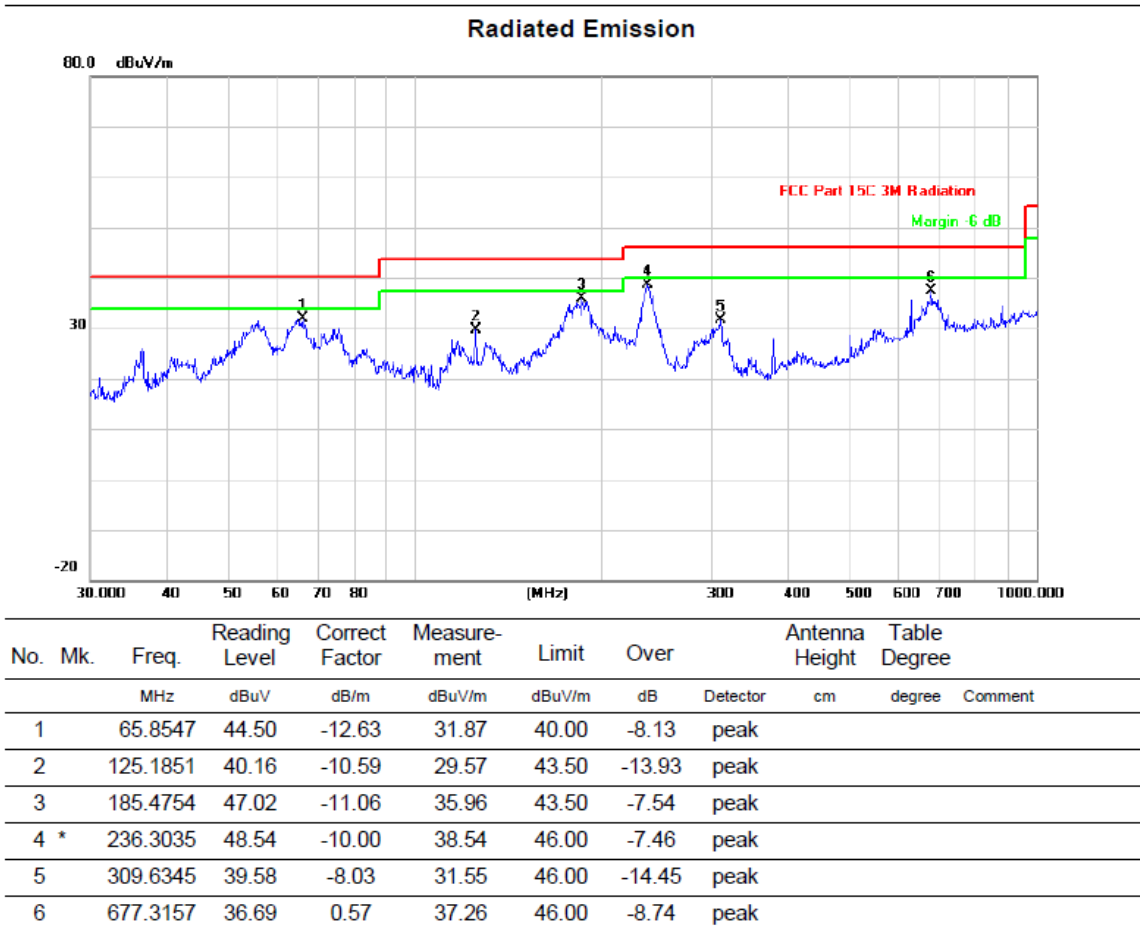

## HORIZONTAL

### Radiated Emission

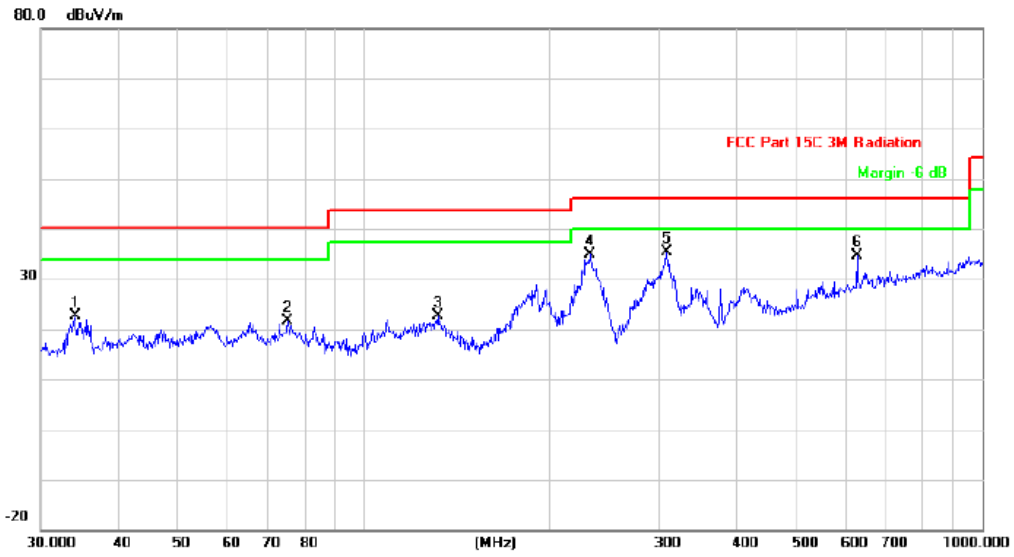

No.	Mk.	Freq.	Reading Level	Correct Factor	Measurement	Limit	Over	Antenna Height	Table Degree	
		MHz	dBuV	dB/m	dBuV/m	dBuV/m	dB	cm	degree	Comment
1		34.0407	34.42	-11.78	22.64	40.00	-17.36			peak
2		75.2514	35.31	-13.69	21.62	40.00	-18.38			peak
3		131.4906	32.85	-10.22	22.63	43.50	-20.87			peak
4		232.1923	45.08	-10.18	34.90	46.00	-11.10			peak
5	*	308.5494	43.54	-8.06	35.48	46.00	-10.52			peak
6		626.9810	34.79	-0.19	34.60	46.00	-11.40			peak

### 3) Radiated emission: Above 1G

**Note:**

1. Measurement = Reading + Correct Factor.
2. Over = Measurement – Limit

Above 1G (1GHz~18GHz)	Test mode:11B-CDD	Test Channel:1
-----------------------	-------------------	----------------

VERTICAL

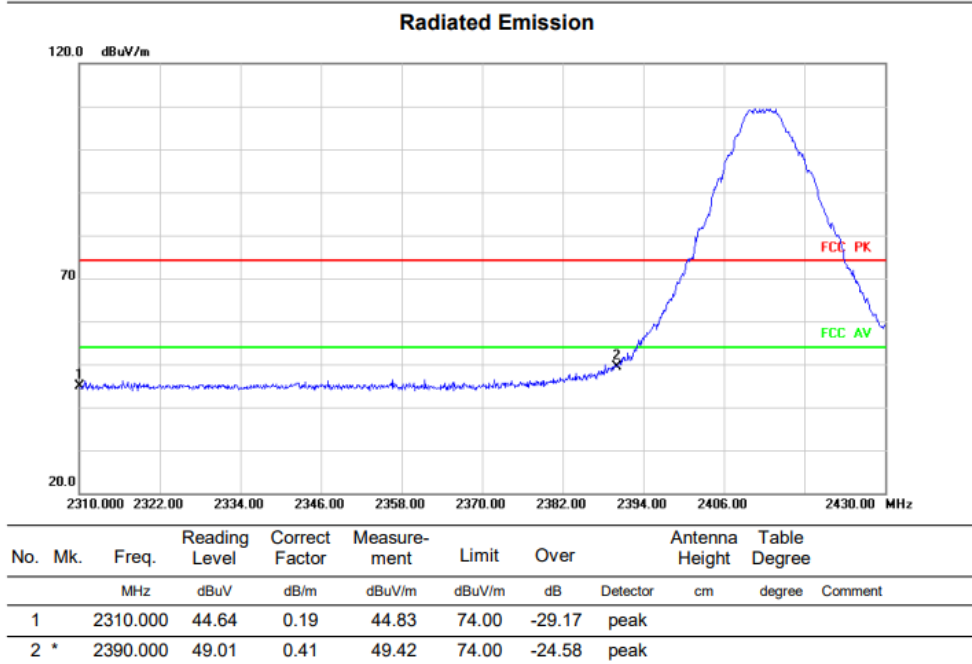
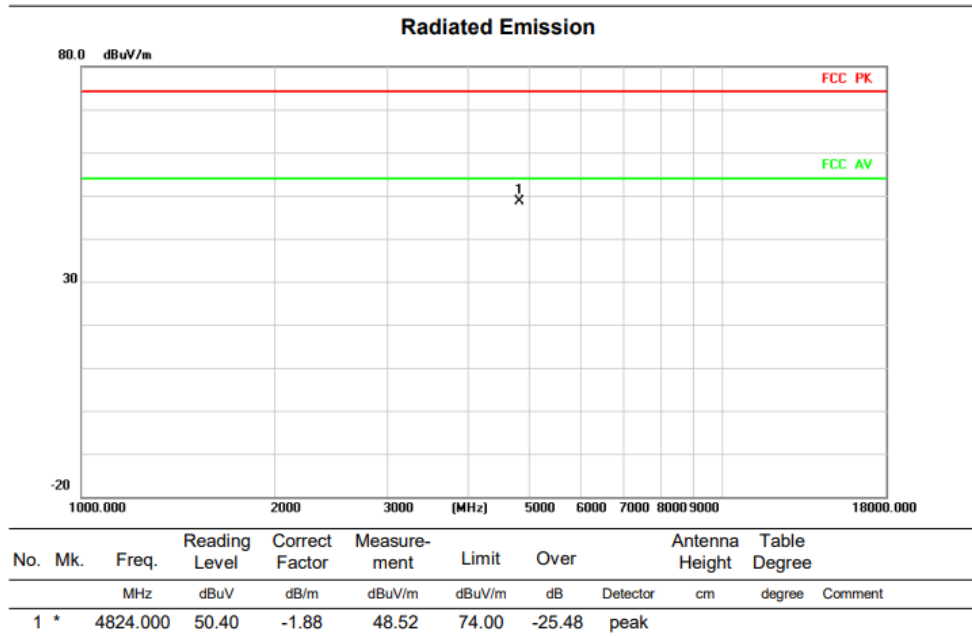

## HORIZONTAL

### Radiated Emission

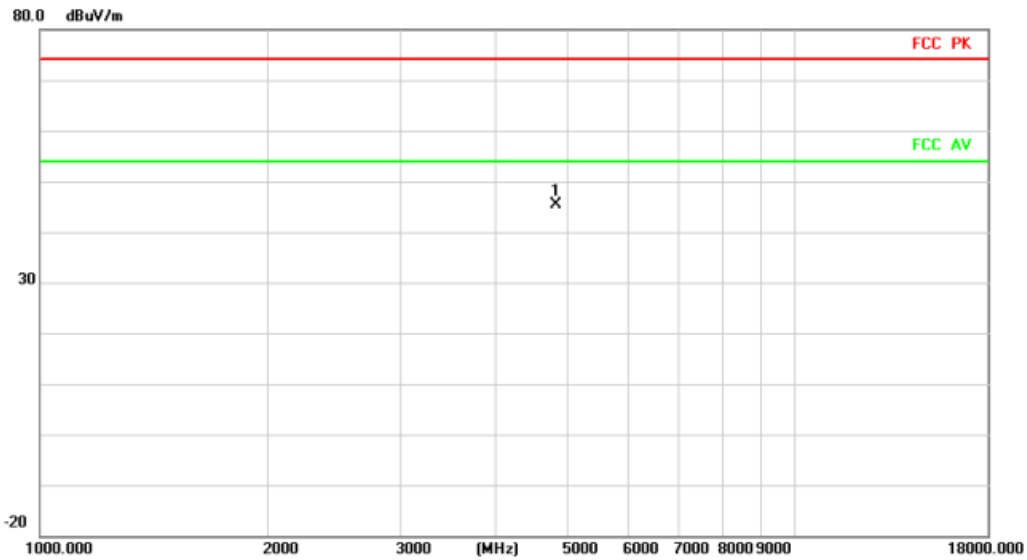

No.	Mk.	Freq.	Reading Level	Correct Factor	Measurement	Limit	Over	Antenna Height	Table Degree	
		MHz	dBuV	dB/m	dBuV/m	dBuV/m	dB	cm	degree	Comment
1	*	4824.000	47.14	-1.88	45.26	74.00	-28.74	peak		

### Radiated Emission

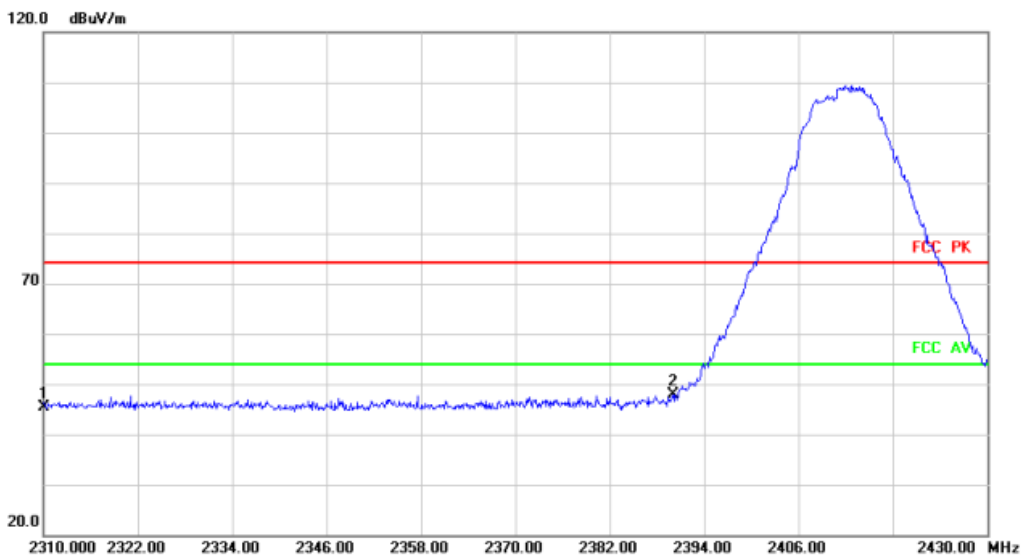

No.	Mk.	Freq.	Reading Level	Correct Factor	Measurement	Limit	Over	Antenna Height	Table Degree	
		MHz	dBuV	dB/m	dBuV/m	dBuV/m	dB	cm	degree	Comment
1		2310.000	45.23	0.19	45.42	74.00	-28.58	peak		
2	*	2390.000	47.53	0.41	47.94	74.00	-26.06	peak		



Above 1G (1GHz~18GHz)

Test mode:11B-CDD

Test Channel: 6

VERTICAL

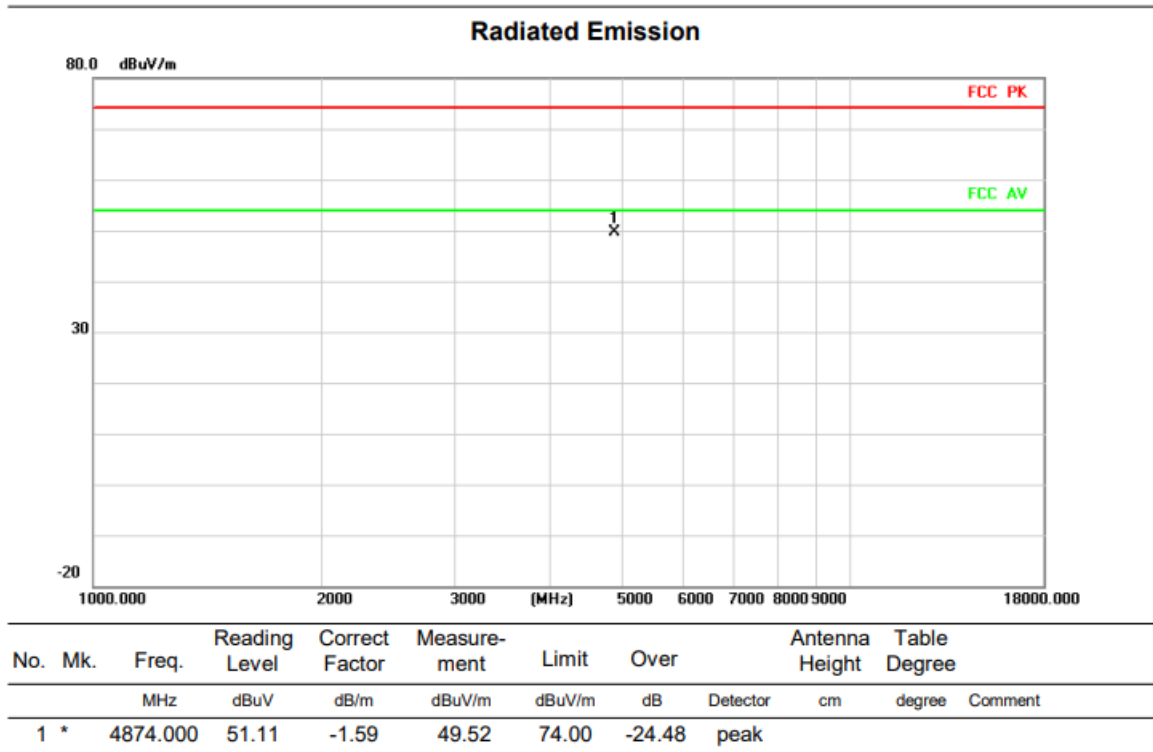

HORIZONTAL

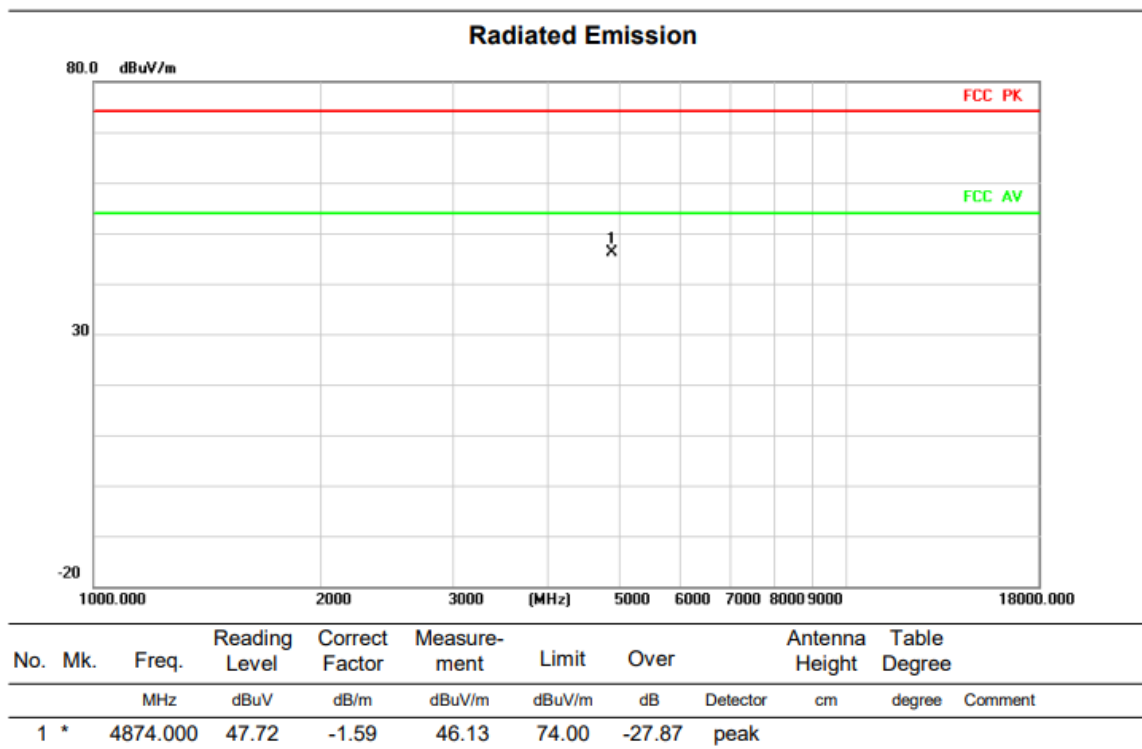

Above 1G (1GHz~18GHz)

Test mode:11B-CDD

Test Channel:11

VERTICAL

**Radiated Emission**

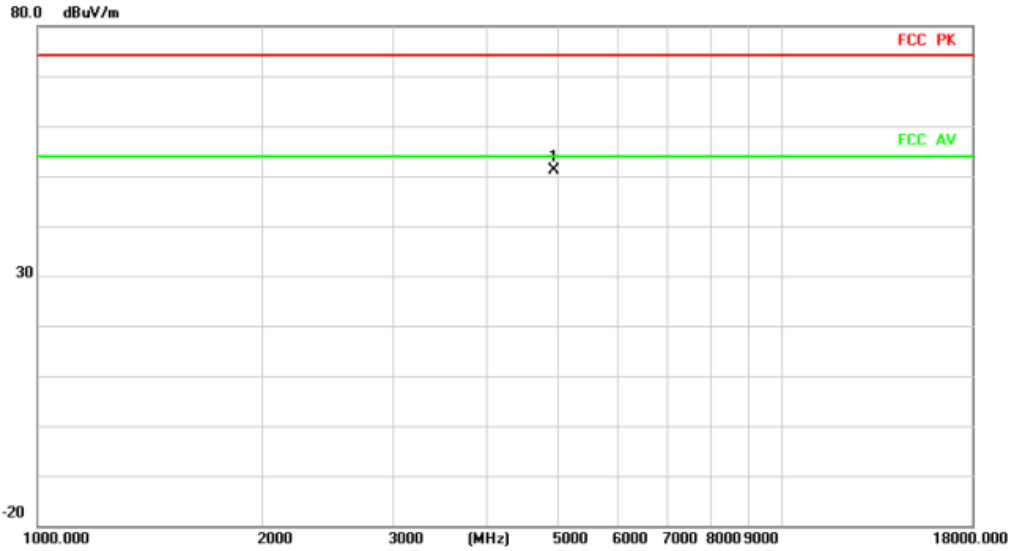

No.	Mk.	Freq.	Reading Level	Correct Factor	Measurement	Limit	Over	Antenna Height	Table Degree
		MHz	dBuV	dB/m	dBuV/m	dBuV/m	dB	cm	degree
1	*	4924.000	52.46	-1.29	51.17	74.00	-22.83	peak	

**Radiated Emission**

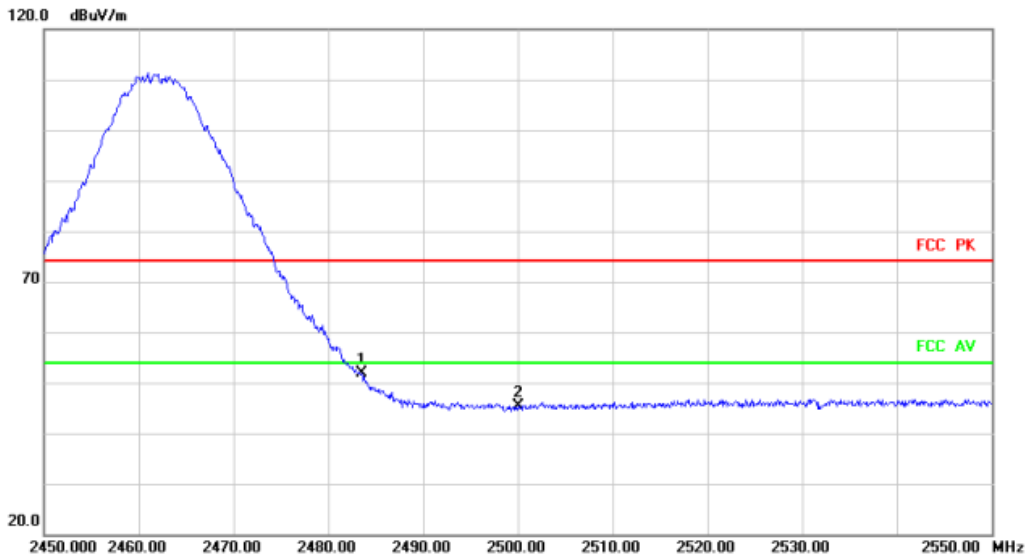

No.	Mk.	Freq.	Reading Level	Correct Factor	Measurement	Limit	Over	Antenna Height	Table Degree
		MHz	dBuV	dB/m	dBuV/m	dBuV/m	dB	cm	degree
1	*	2483.500	50.82	1.09	51.91	74.00	-22.09	peak	
2		2500.000	44.14	1.22	45.36	74.00	-28.64	peak	

HORIZONTAL

Radiated Emission

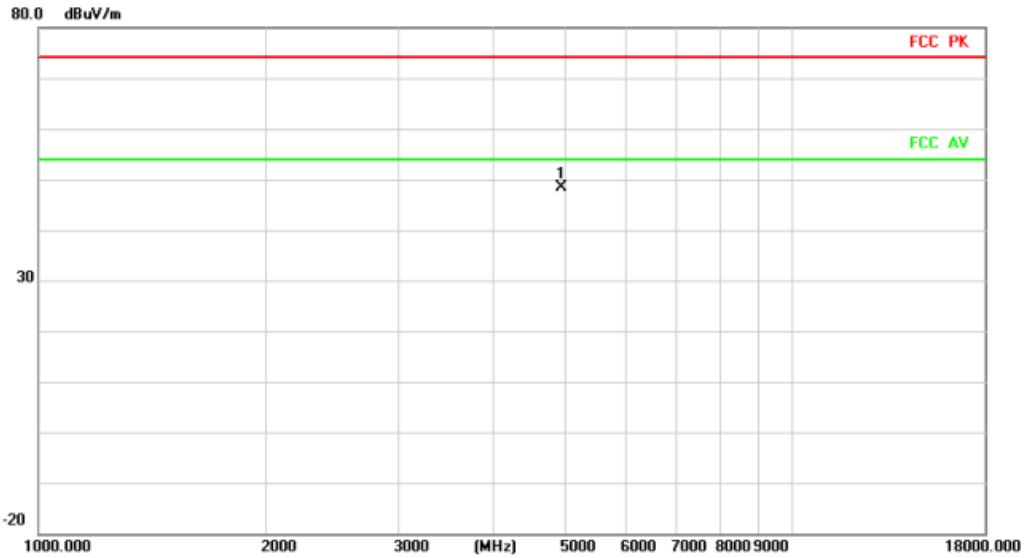

No.	Mk.	Freq.	Reading Level	Correct Factor	Measurement	Limit	Over	Antenna Height	Table Degree	
		MHz	dBuV	dB/m	dBuV/m	dBuV/m	dB	cm	degree	Comment
1	*	4924.000	49.59	-1.29	48.30	74.00	-25.70			peak

Radiated Emission

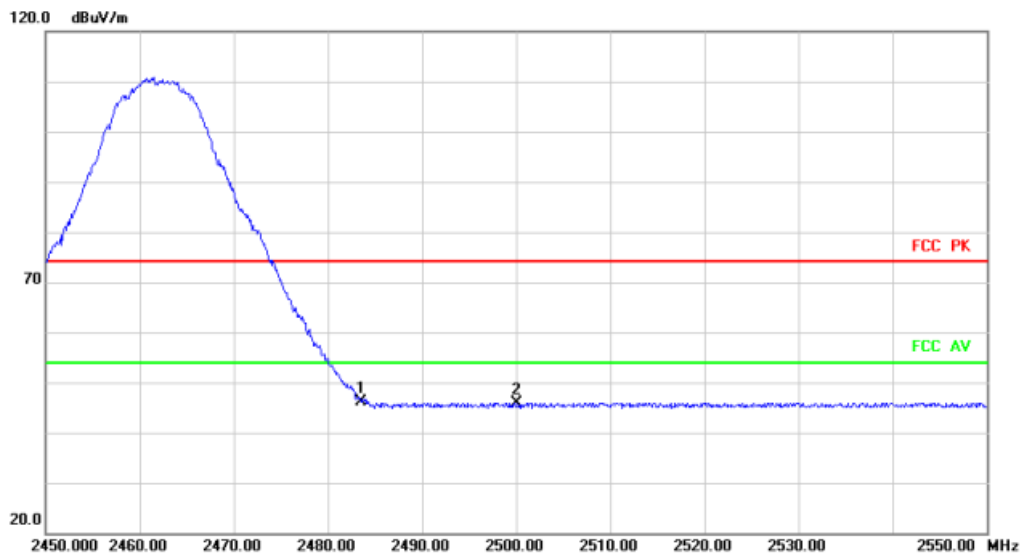

No.	Mk.	Freq.	Reading Level	Correct Factor	Measurement	Limit	Over	Antenna Height	Table Degree	
		MHz	dBuV	dB/m	dBuV/m	dBuV/m	dB	cm	degree	Comment
1	*	2483.500	45.06	1.09	46.15	74.00	-27.85			peak
2		2500.000	44.68	1.22	45.90	74.00	-28.10			peak

Above 1G (1GHz~18GHz)

Test mode:11G-CDD

Test Channel:1

VERTICAL

**Radiated Emission**

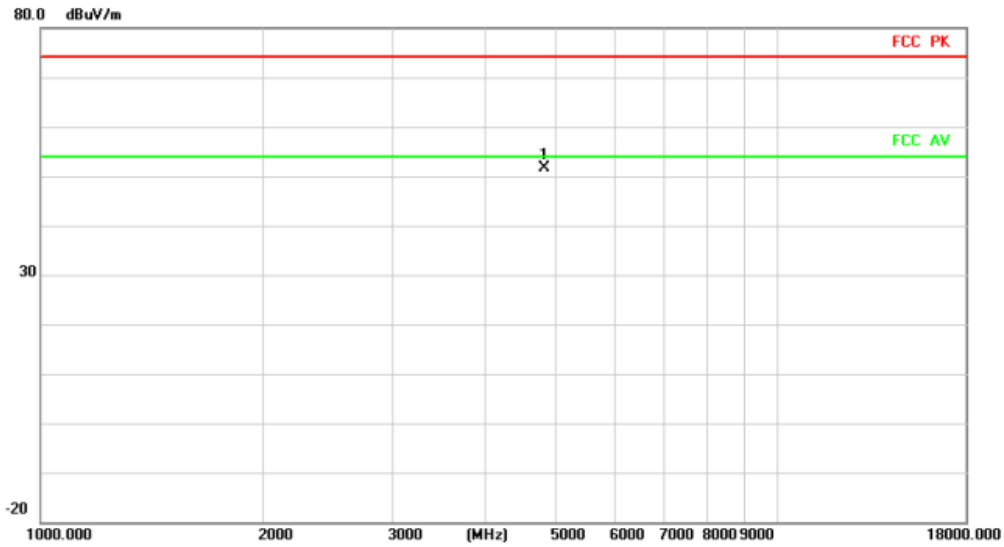

No.	Mk.	Freq.	Reading Level	Correct Factor	Measurement	Limit	Over	Antenna Height	Table Degree
		MHz	dBuV	dB/m	dBuV/m	dBuV/m	dB	cm	degree
1	*	4824.000	53.55	-1.88	51.67	74.00	-22.33	peak	

**Radiated Emission**

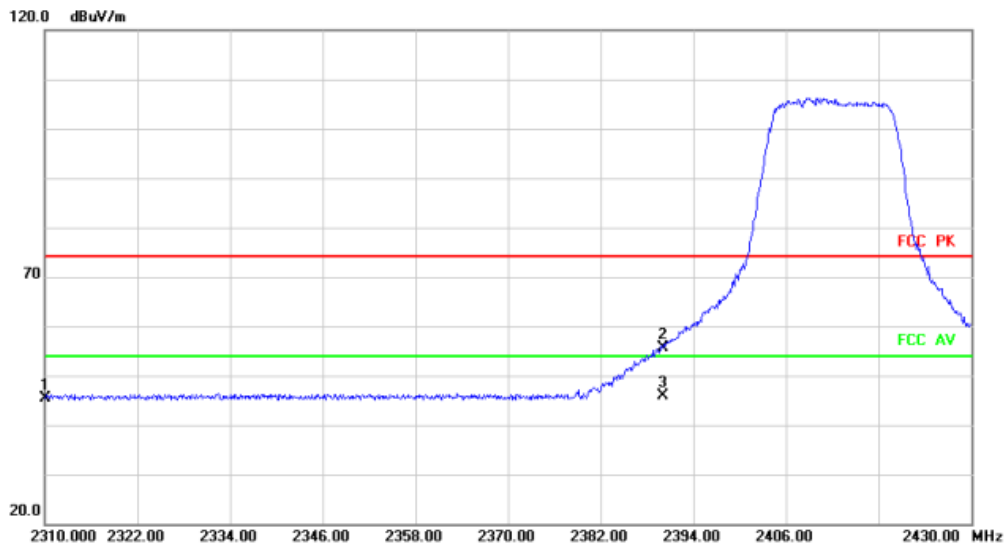

No.	Mk.	Freq.	Reading Level	Correct Factor	Measurement	Limit	Over	Antenna Height	Table Degree
		MHz	dBuV	dB/m	dBuV/m	dBuV/m	dB	cm	degree
1		2310.000	45.26	0.19	45.45	74.00	-28.55	peak	
2		2390.000	55.17	0.41	55.58	74.00	-18.42	peak	
3	*	2390.000	45.48	0.41	45.89	54.00	-8.11	AVG	

### HORIZONTALA

#### Radiated Emission



No.	Mk.	Freq.	Reading Level	Correct Factor	Measurement	Limit	Over	Antenna Height	Table Degree	
		MHz	dBuV	dB/m	dBuV/m	dBuV/m	dB	cm	degree	Comment
1	*	4824.000	50.43	-1.88	48.55	74.00	-25.45	peak		

#### Radiated Emission

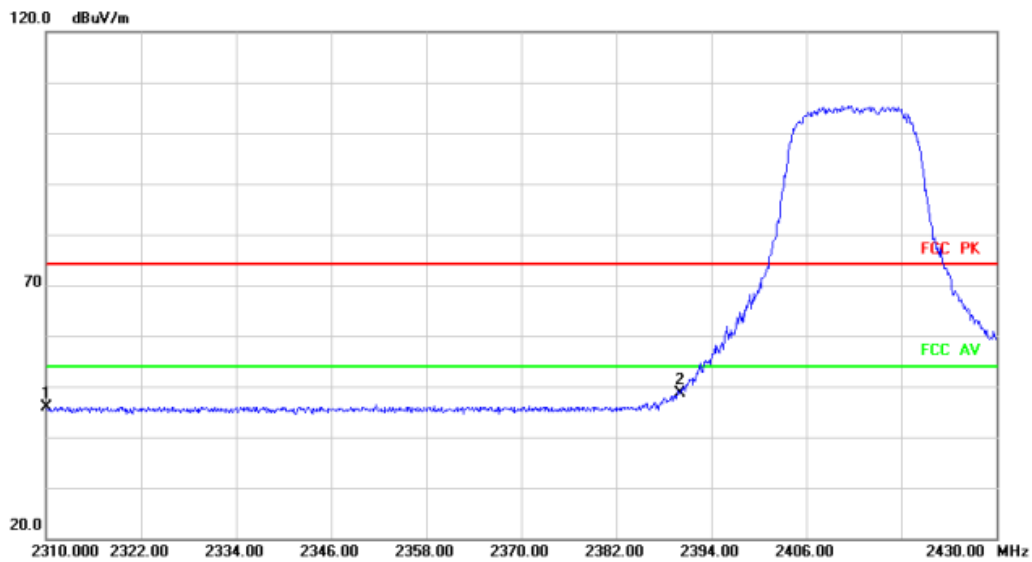

No.	Mk.	Freq.	Reading Level	Correct Factor	Measurement	Limit	Over	Antenna Height	Table Degree	
		MHz	dBuV	dB/m	dBuV/m	dBuV/m	dB	cm	degree	Comment
1		2310.000	45.74	0.19	45.93	74.00	-28.07	peak		
2	*	2390.000	48.11	0.41	48.52	74.00	-25.48	peak		

Above 1G (1GHz~18GHz)

Test mode:11G-CDD

Test Channel: 6

VERTICAL

**Radiated Emission**

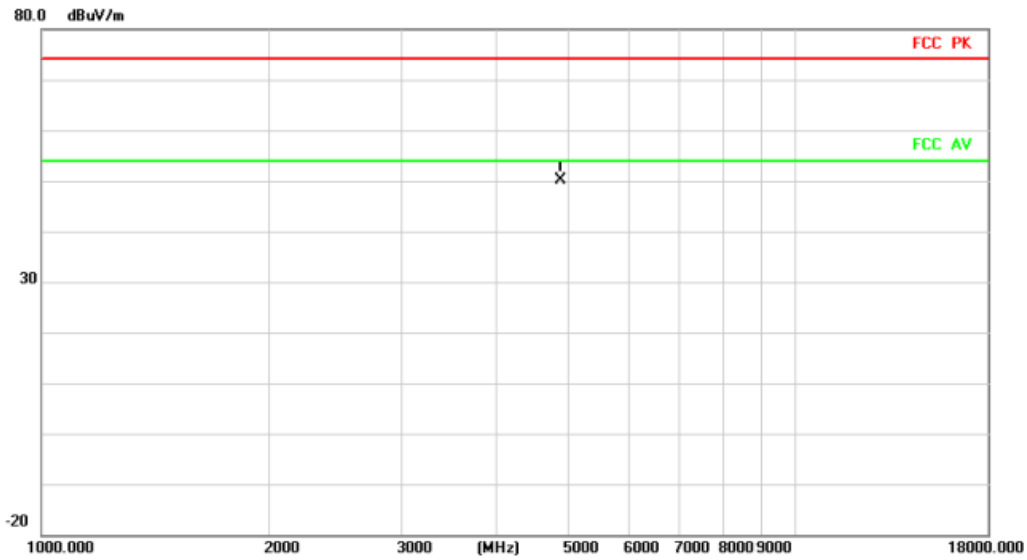

No.	Mk.	Freq.	Reading Level	Correct Factor	Measurement	Limit	Over	Antenna Height	Table Degree		
		MHz	dBuV	dB/m	dBuV/m	dBuV/m	dB	Detector	cm	degree	Comment
1	*	4874.000	51.78	-1.59	50.19	74.00	-23.81	peak			

HORIZONTAL

**Radiated Emission**

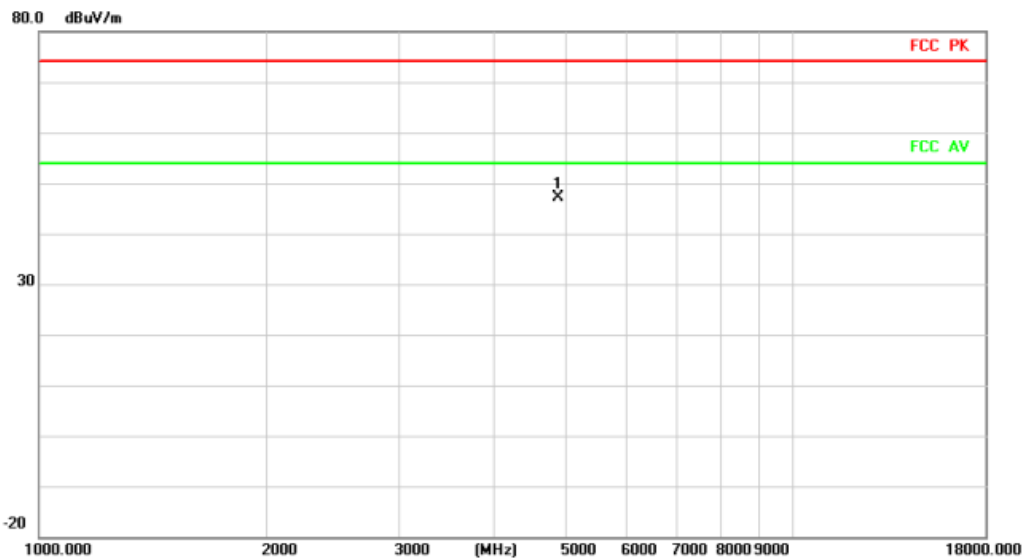

No.	Mk.	Freq.	Reading Level	Correct Factor	Measurement	Limit	Over	Antenna Height	Table Degree		
		MHz	dBuV	dB/m	dBuV/m	dBuV/m	dB	Detector	cm	degree	Comment
1	*	4874.000	48.82	-1.59	47.23	74.00	-26.77	peak			

Above 1G (1GHz~18GHz)

Test mode:11G-CDD

Test Channel:11

VERTICAL

**Radiated Emission**

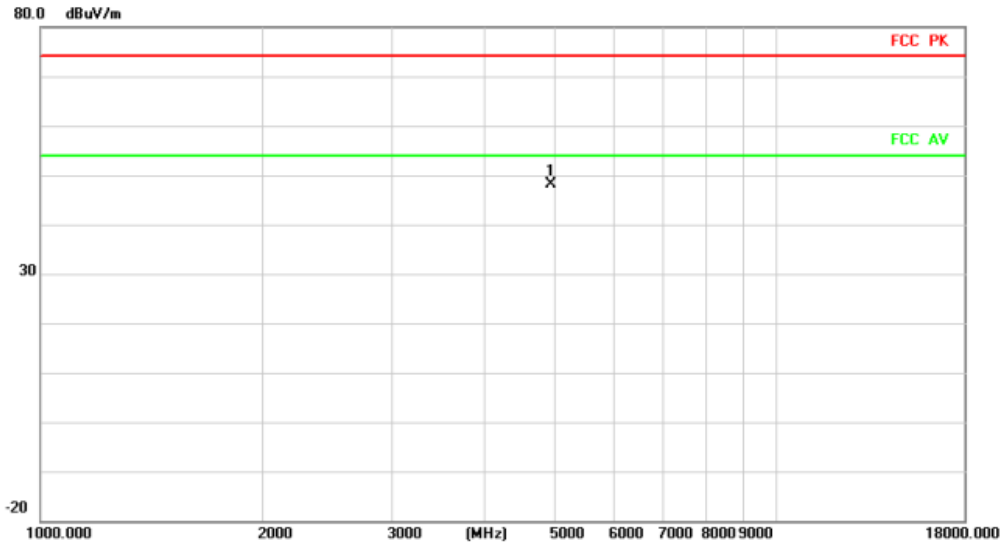

No.	Mk.	Freq.	Reading Level	Correct Factor	Measurement	Limit	Over	Antenna Height	Table Degree
		MHz	dBuV	dB/m	dBuV/m	dBuV/m	dB	cm	degree
1	*	4924.000	49.40	-1.29	48.11	74.00	-25.89	peak	

**Radiated Emission**

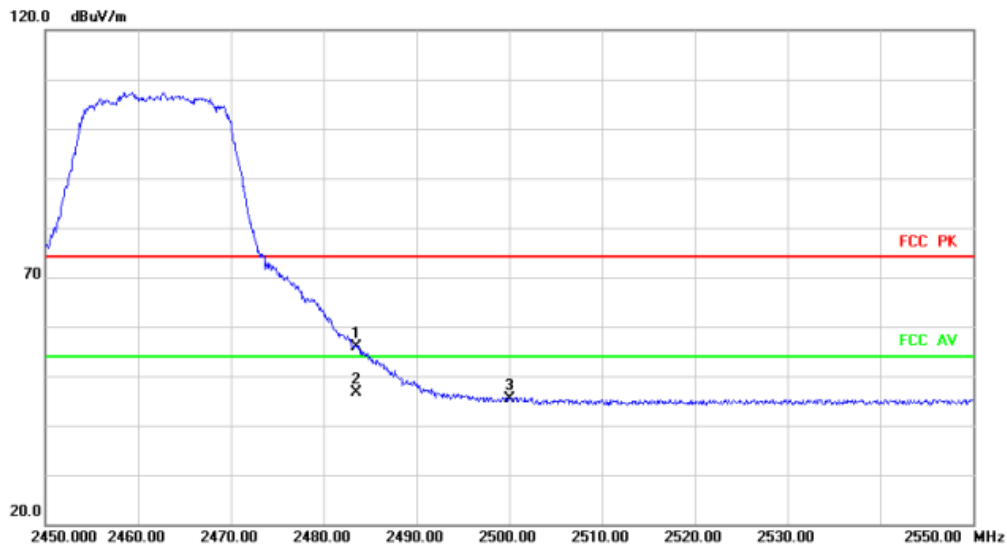

No.	Mk.	Freq.	Reading Level	Correct Factor	Measurement	Limit	Over	Antenna Height	Table Degree
		MHz	dBuV	dB/m	dBuV/m	dBuV/m	dB	cm	degree
1		2483.500	54.90	1.09	55.99	74.00	-18.01	peak	
2	*	2483.500	45.43	1.09	46.52	54.00	-7.48	AVG	
3		2500.000	44.15	1.22	45.37	74.00	-28.63	peak	

## HORIZONTALA

### Radiated Emission

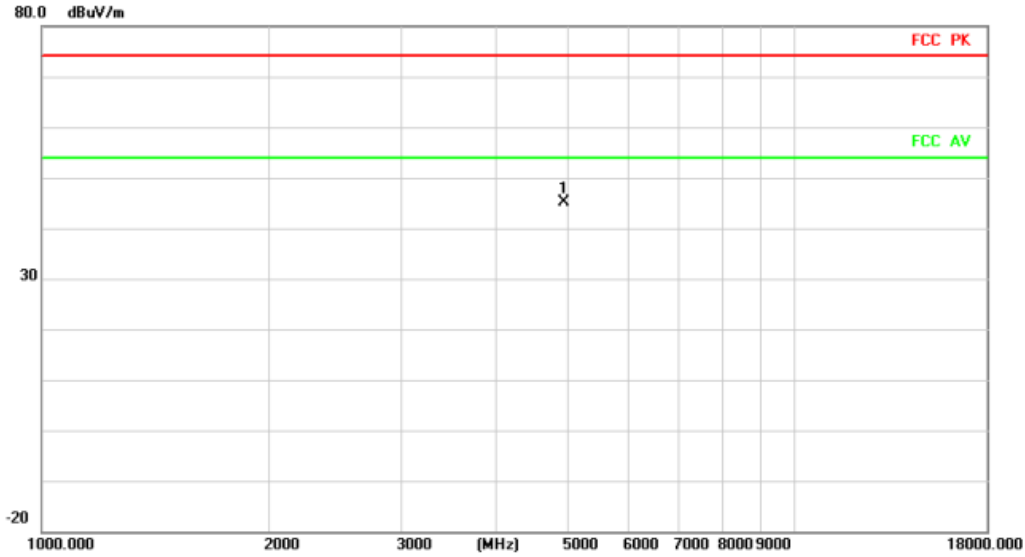

No.	Mk.	Freq.	Reading Level	Correct Factor	Measurement	Limit	Over	Antenna Height	Table Degree	
		MHz	dBuV	dB/m	dBuV/m	dBuV/m	dB	cm	degree	Comment
1	*	4924.000	46.52	-1.29	45.23	74.00	-28.77			peak

### Radiated Emission

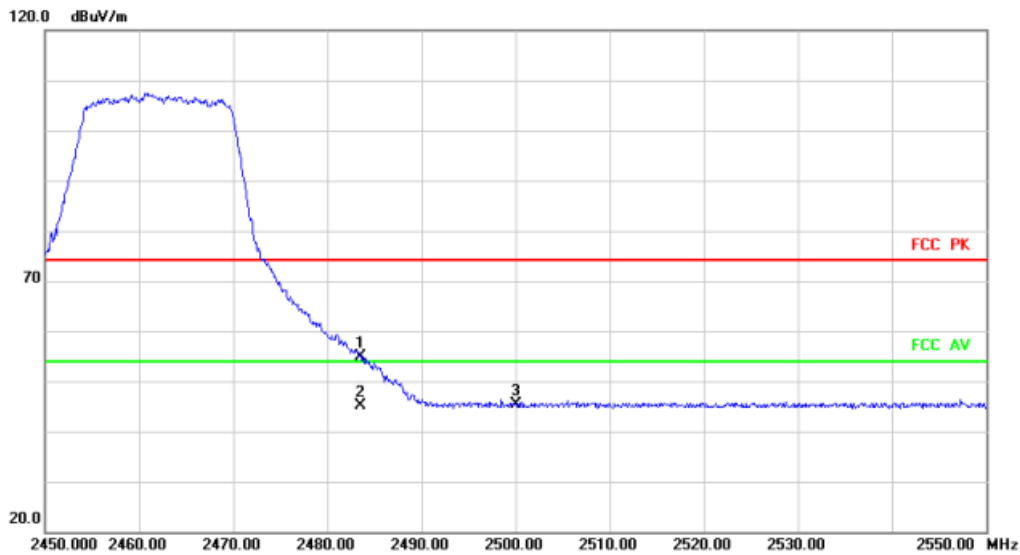

No.	Mk.	Freq.	Reading Level	Correct Factor	Measurement	Limit	Over	Antenna Height	Table Degree	
		MHz	dBuV	dB/m	dBuV/m	dBuV/m	dB	cm	degree	Comment
1		2483.500	53.80	1.09	54.89	74.00	-19.11			peak
2	*	2483.500	44.06	1.09	45.15	54.00	-8.85			AVG
3		2500.000	44.05	1.22	45.27	74.00	-28.73			peak



Above 1G (1GHz~18GHz)

Test mode: 11N20MIMO

Test Channel:1

VERTICAL

**Radiated Emission**

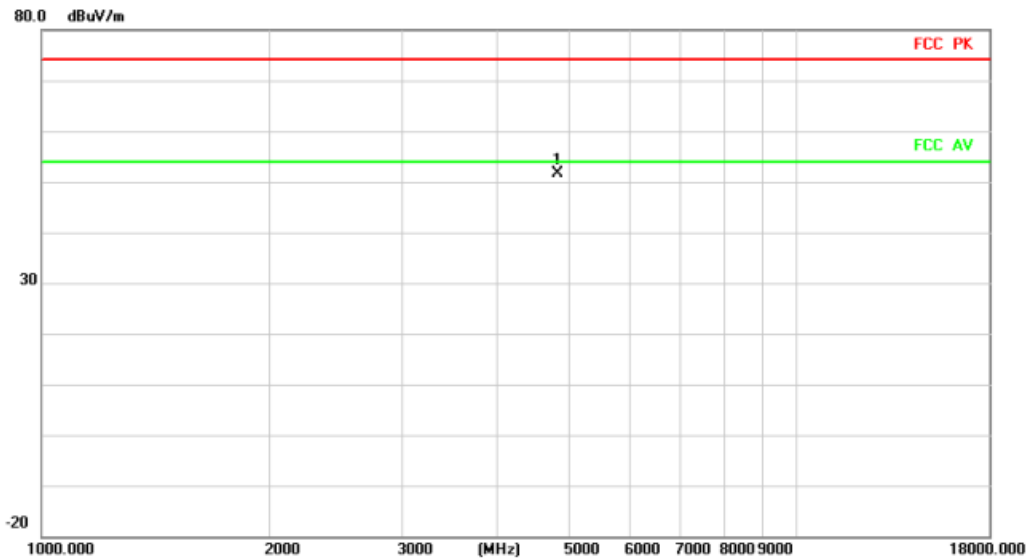

No.	Mk.	Freq.	Reading Level	Correct Factor	Measurement	Limit	Over	Antenna Height	Table Degree
		MHz	dBuV	dB/m	dBuV/m	dBuV/m	dB	cm	degree
1	*	4824.000	53.54	-1.88	51.66	74.00	-22.34	peak	

**Radiated Emission**

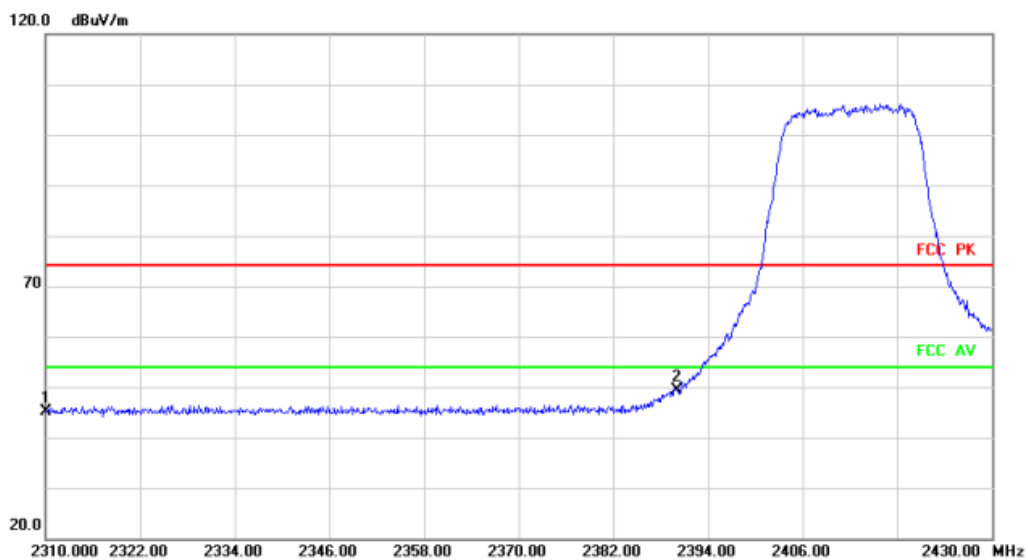

No.	Mk.	Freq.	Reading Level	Correct Factor	Measurement	Limit	Over	Antenna Height	Table Degree
		MHz	dBuV	dB/m	dBuV/m	dBuV/m	dB	cm	degree
1		2310.000	45.06	0.19	45.25	74.00	-28.75	peak	
2	*	2390.000	49.08	0.41	49.49	74.00	-24.51	peak	

## HORIZONTAL

### Radiated Emission

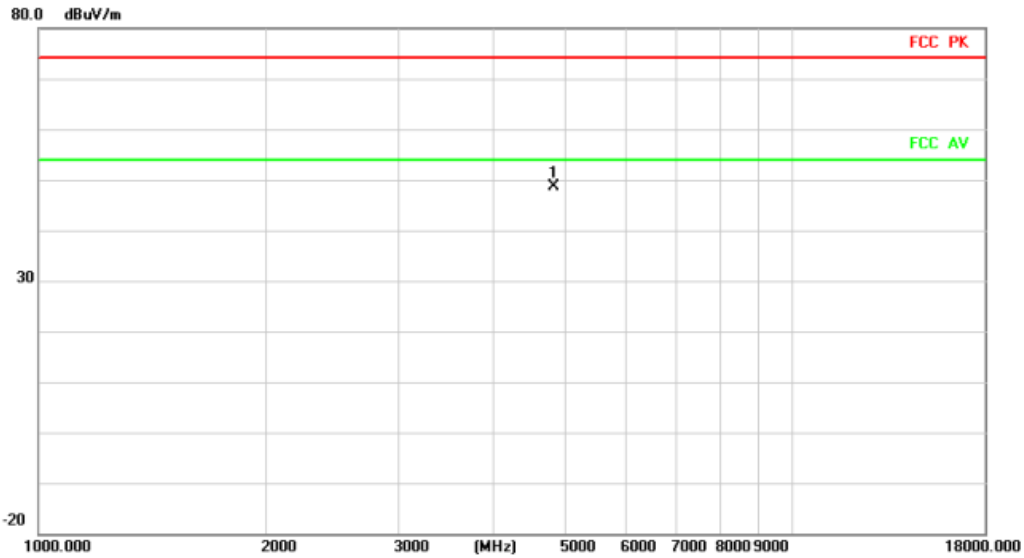

No.	Mk.	Freq.	Reading Level	Correct Factor	Measurement	Limit	Over	Antenna Height	Table Degree	
		MHz	dBuV	dB/m	dBuV/m	dBuV/m	dB	cm	degree	Comment
1	*	4824.000	50.39	-1.88	48.51	74.00	-25.49	peak		

### Radiated Emission

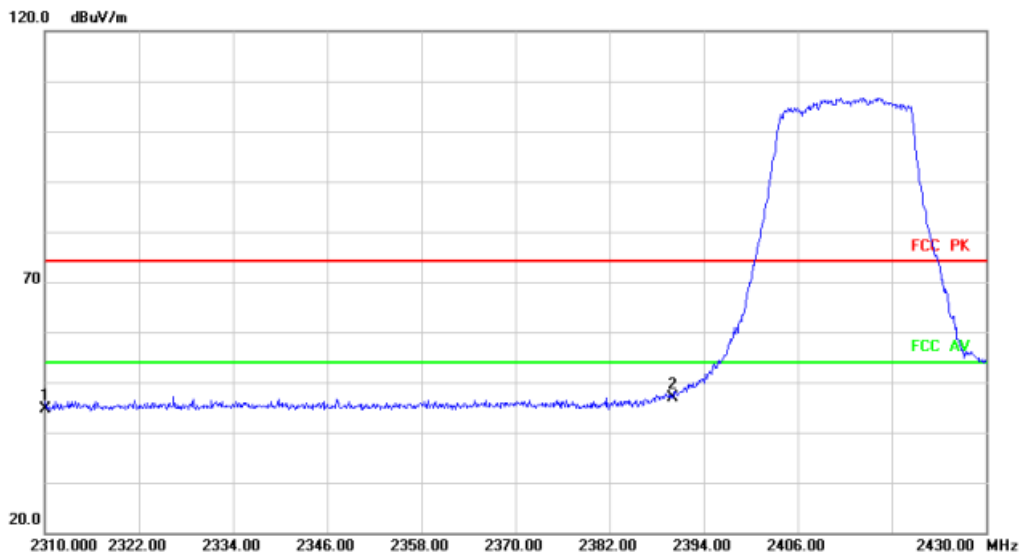

No.	Mk.	Freq.	Reading Level	Correct Factor	Measurement	Limit	Over	Antenna Height	Table Degree	
		MHz	dBuV	dB/m	dBuV/m	dBuV/m	dB	cm	degree	Comment
1		2310.000	44.34	0.19	44.53	74.00	-29.47	peak		
2	*	2390.000	46.41	0.41	46.82	74.00	-27.18	peak		

Above 1G (1GHz~18GHz)

Test mode: 11N20MIMO

Test Channel: 6

VERTICAL

**Radiated Emission**

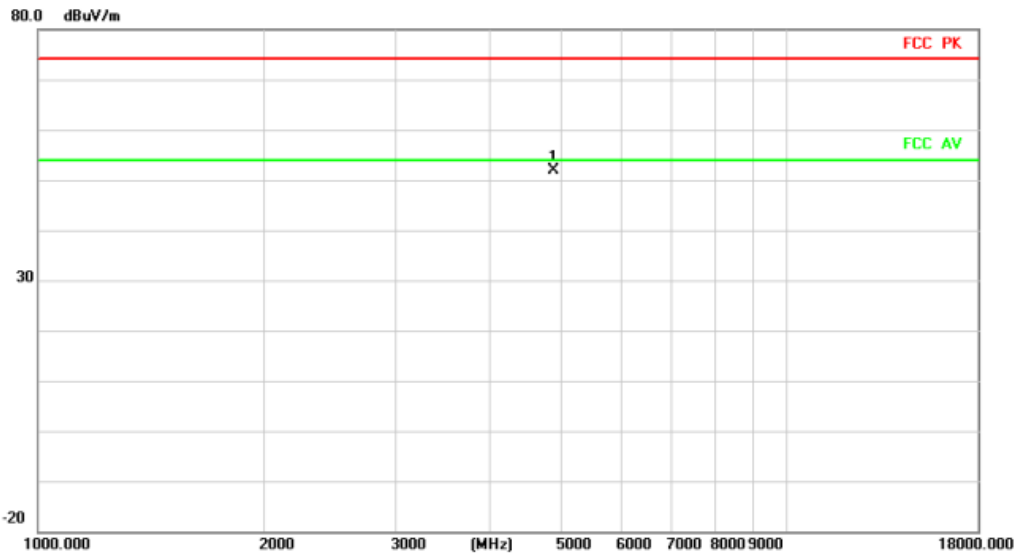

No.	Mk.	Freq.	Reading Level	Correct Factor	Measurement	Limit	Over	Antenna Height	Table Degree
		MHz	dBuV	dB/m	dBuV/m	dBuV/m	dB	cm	degree
1	*	4874.000	53.40	-1.59	51.81	74.00	-22.19	peak	

HORIZONTAL

**Radiated Emission**

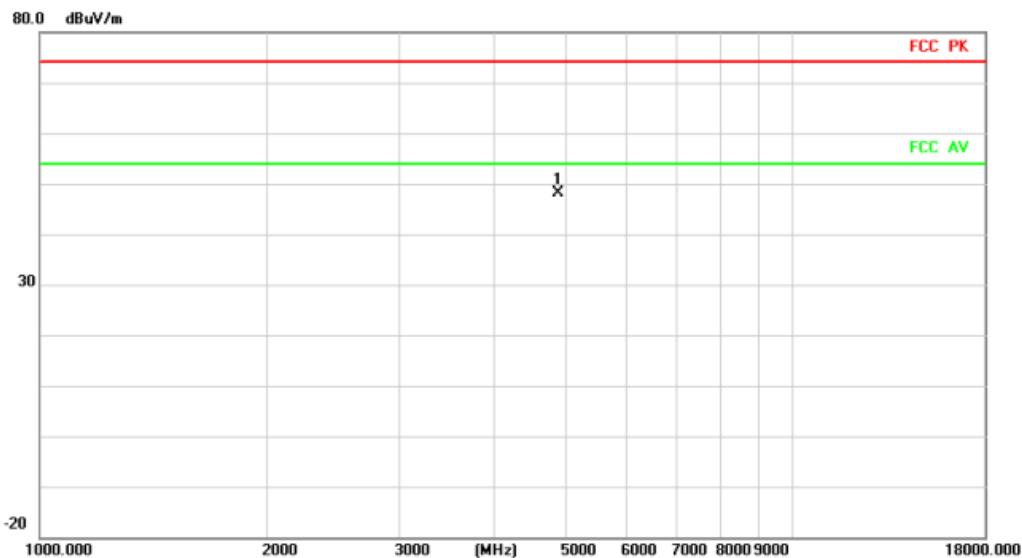

No.	Mk.	Freq.	Reading Level	Correct Factor	Measurement	Limit	Over	Antenna Height	Table Degree
		MHz	dBuV	dB/m	dBuV/m	dBuV/m	dB	cm	degree
1	*	4874.000	49.81	-1.59	48.22	74.00	-25.78	peak	

Above 1G (1GHz~18GHz)

Test mode: 11N20MIMO

Test Channel:11

VERTICAL

**Radiated Emission**

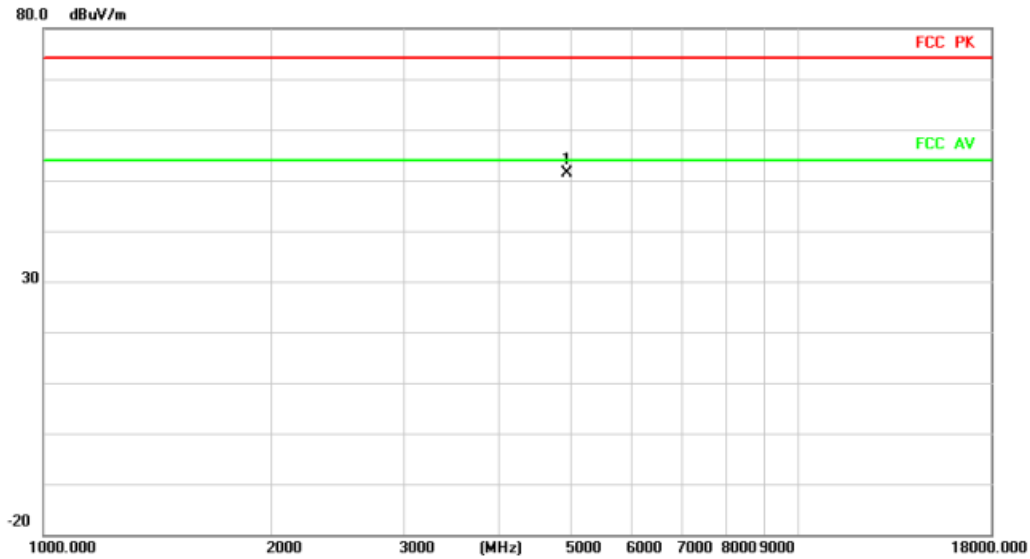

No.	Mk.	Freq.	Reading Level	Correct Factor	Measurement	Limit	Over	Antenna Height	Table Degree
		MHz	dBuV	dB/m	dBuV/m	dBuV/m	dB	cm	degree
1	*	4924.000	52.77	-1.29	51.48	74.00	-22.52	peak	

**Radiated Emission**

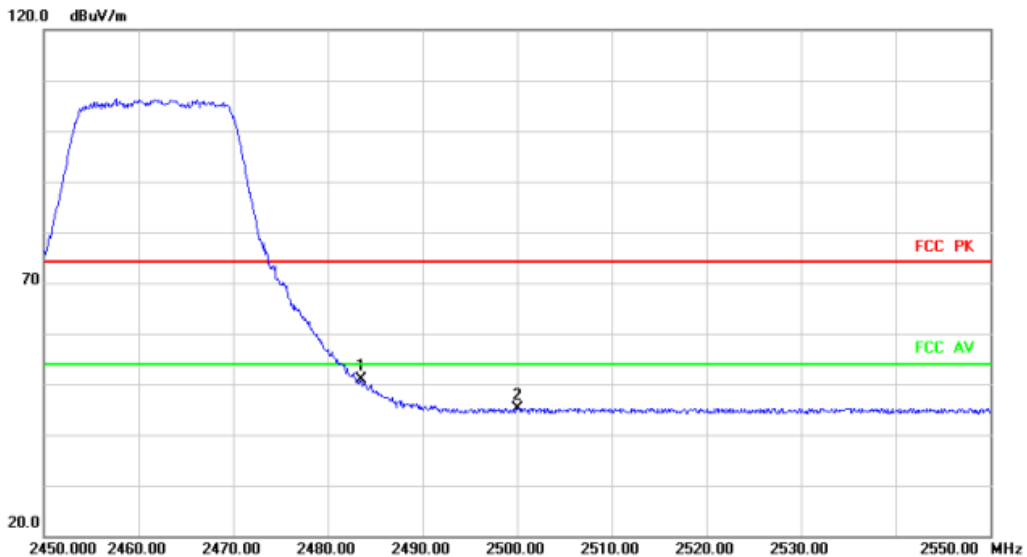

No.	Mk.	Freq.	Reading Level	Correct Factor	Measurement	Limit	Over	Antenna Height	Table Degree
		MHz	dBuV	dB/m	dBuV/m	dBuV/m	dB	cm	degree
1	*	2483.500	49.77	1.09	50.86	74.00	-23.14	peak	
2		2500.000	43.85	1.22	45.07	74.00	-28.93	peak	

### HORIZONTALA

#### Radiated Emission

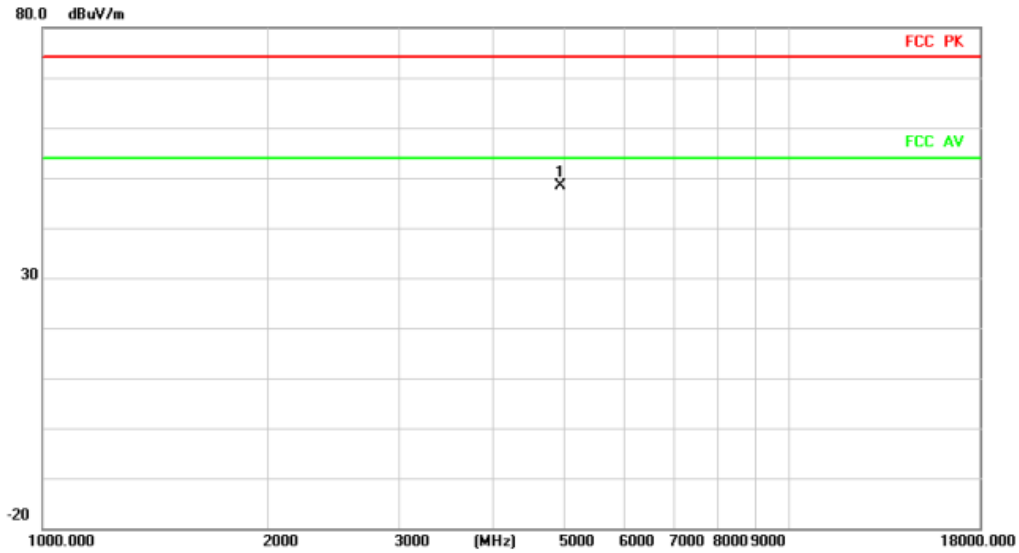

No.	Mk.	Freq.	Reading Level	Correct Factor	Measurement	Limit	Over	Antenna Height	Table Degree	
		MHz	dBuV	dB/m	dBuV/m	dBuV/m	dB	cm	degree	Comment
1	*	4924.000	49.56	-1.29	48.27	74.00	-25.73			peak

#### Radiated Emission

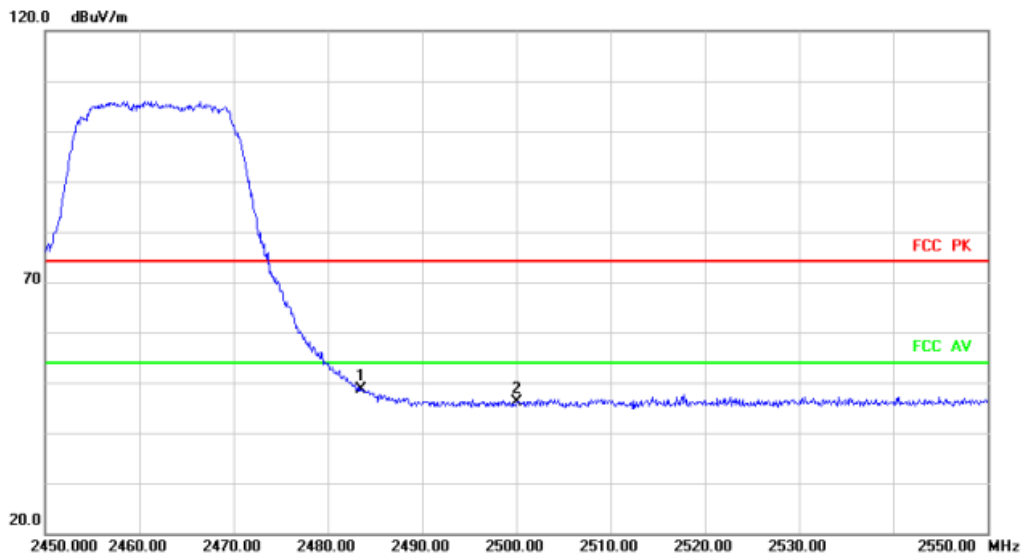

No.	Mk.	Freq.	Reading Level	Correct Factor	Measurement	Limit	Over	Antenna Height	Table Degree	
		MHz	dBuV	dB/m	dBuV/m	dBuV/m	dB	cm	degree	Comment
1	*	2483.500	47.46	1.09	48.55	74.00	-25.45			peak
2		2500.000	44.85	1.22	46.07	74.00	-27.93			peak

Above 1G (1GHz~18GHz)

Test mode: 11N40MIMO

Test Channel:3

VERTICAL

**Radiated Emission**

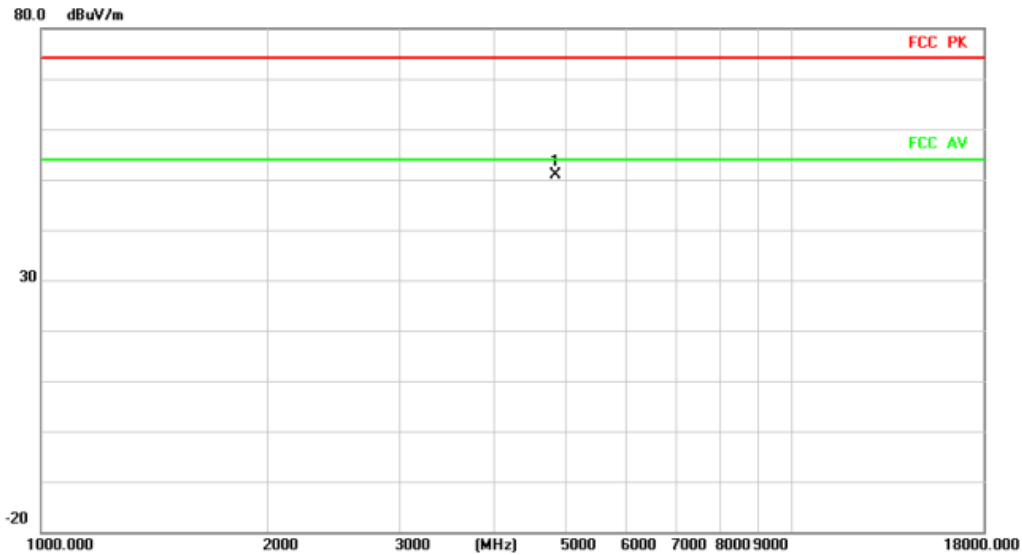

No.	Mk.	Freq.	Reading Level	Correct Factor	Measurement	Limit	Over	Antenna Height	Table Degree
		MHz	dBuV	dB/m	dBuV/m	dBuV/m	dB	cm	degree
1	*	4844.000	52.61	-1.77	50.84	74.00	-23.16	peak	

**Radiated Emission**

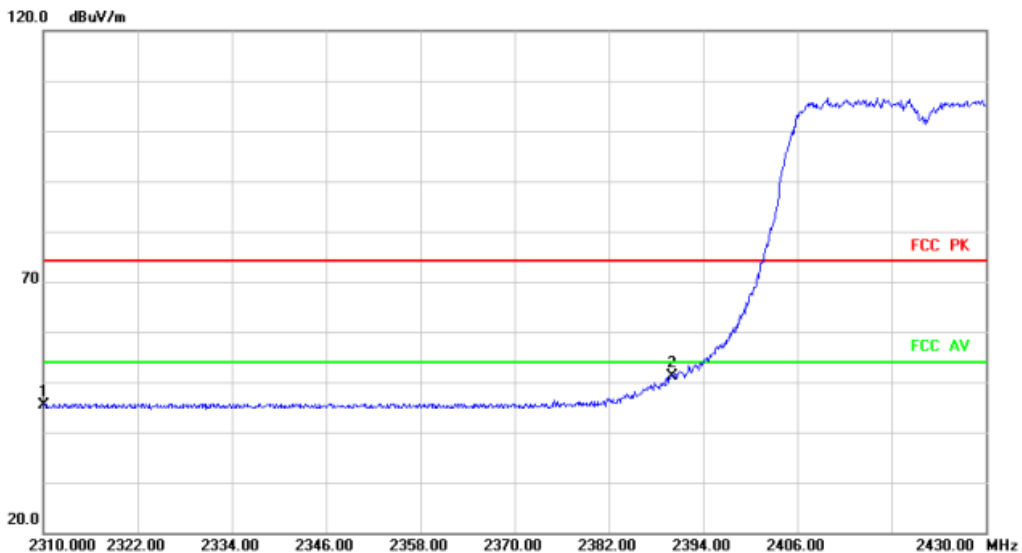

No.	Mk.	Freq.	Reading Level	Correct Factor	Measurement	Limit	Over	Antenna Height	Table Degree
		MHz	dBuV	dB/m	dBuV/m	dBuV/m	dB	cm	degree
1		2310.000	45.10	0.19	45.29	74.00	-28.71	peak	
2	*	2390.000	50.71	0.41	51.12	74.00	-22.88	peak	

HORIZONTAL

Radiated Emission

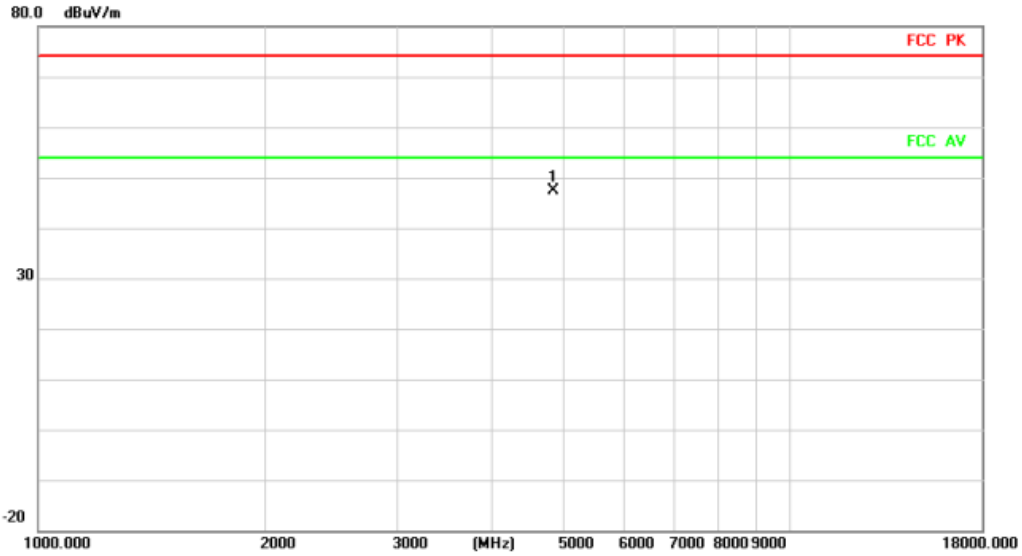

No.	Mk.	Freq.	Reading Level	Correct Factor	Measurement	Limit	Over	Antenna Height	Table Degree	Comment
		MHz	dBuV	dB/m	dBuV/m	dBuV/m	dB	cm	degree	
1	*	4844.000	49.27	-1.77	47.50	74.00	-26.50	peak		

Radiated Emission

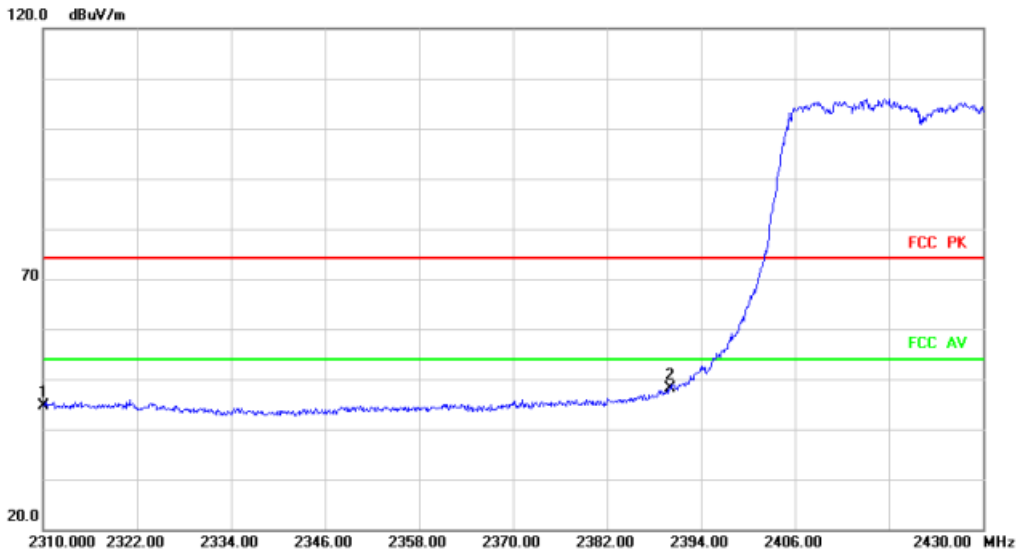

No.	Mk.	Freq.	Reading Level	Correct Factor	Measurement	Limit	Over	Antenna Height	Table Degree	Comment
		MHz	dBuV	dB/m	dBuV/m	dBuV/m	dB	cm	degree	
1		2310.000	44.40	0.19	44.59	74.00	-29.41	peak		
2	*	2390.000	47.66	0.41	48.07	74.00	-25.93	peak		

Above 1G (1GHz~18GHz)

Test mode: 11N40MIMO

Test Channel: 6

VERTICAL

**Radiated Emission**

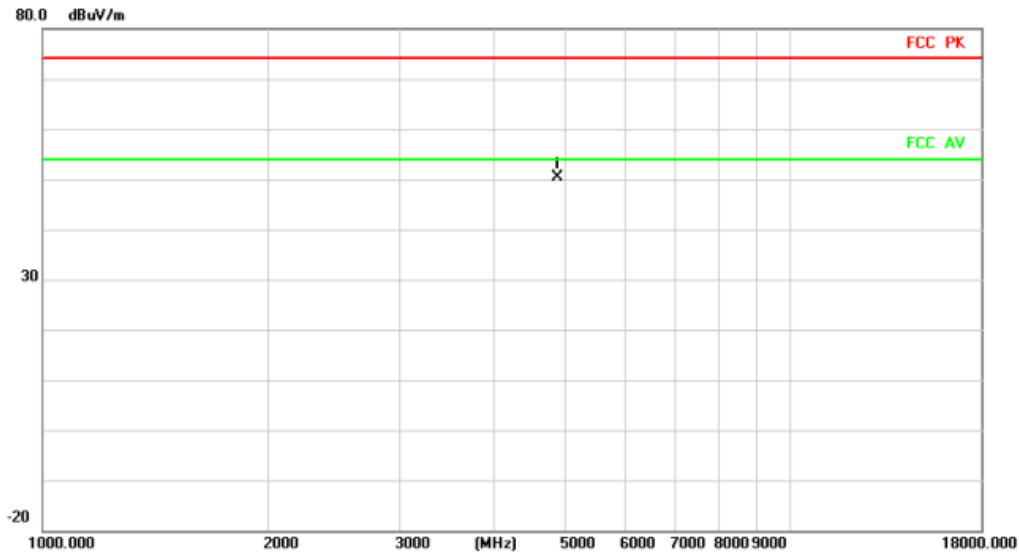

No.	Mk.	Freq.	Reading Level	Correct Factor	Measurement	Limit	Over	Antenna Height	Table Degree	
		MHz	dBuV	dB/m	dBuV/m	dBuV/m	dB	cm	degree	Comment
1	*	4874.000	52.07	-1.59	50.48	74.00	-23.52	peak		

HORIZONTAL

**Radiated Emission**

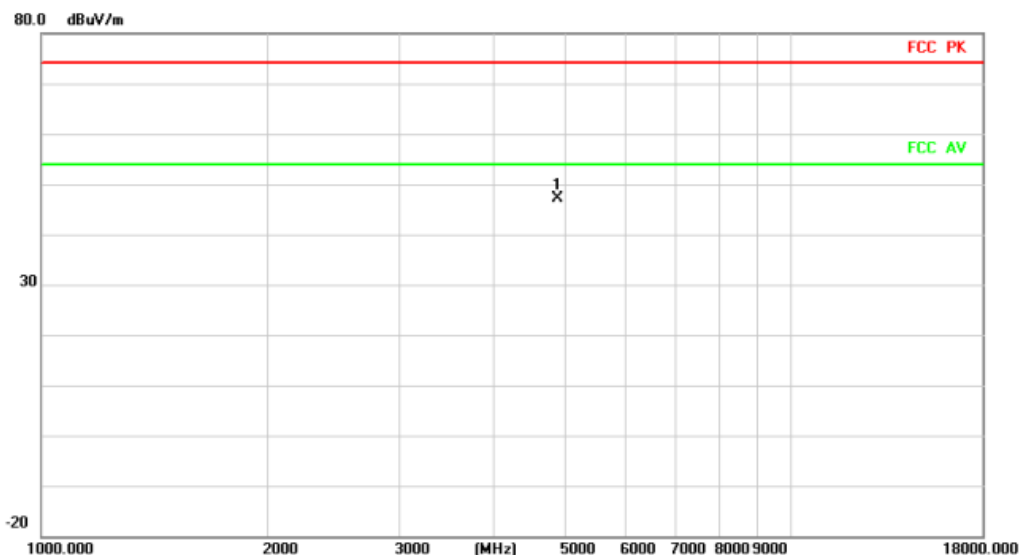

No.	Mk.	Freq.	Reading Level	Correct Factor	Measurement	Limit	Over	Antenna Height	Table Degree	
		MHz	dBuV	dB/m	dBuV/m	dBuV/m	dB	cm	degree	Comment
1	*	4874.000	48.76	-1.59	47.17	74.00	-26.83	peak		



Above 1G (1GHz~18GHz)

Test mode: 11N40MIMO

Test Channel:9

VERTICAL

**Radiated Emission**

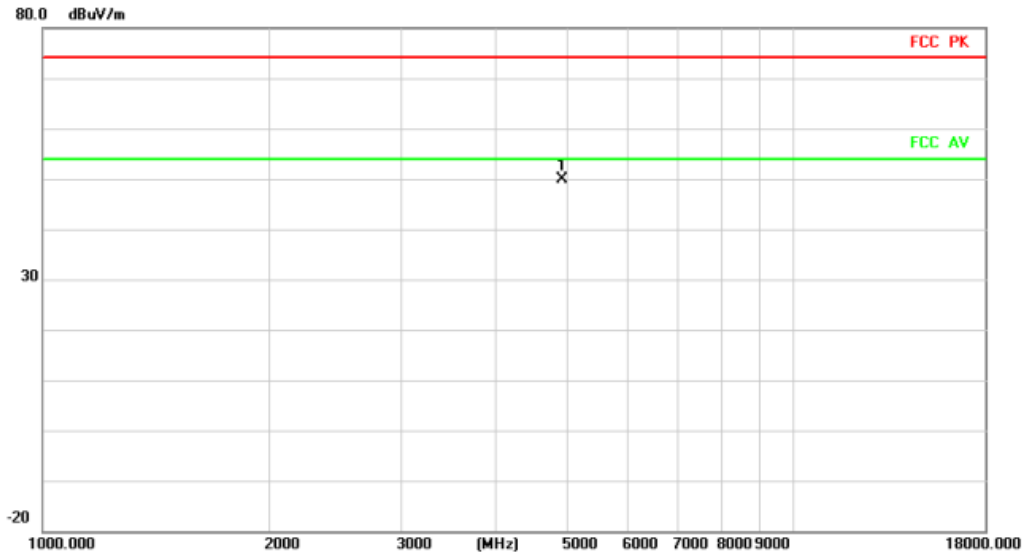

No.	Mk.	Freq.	Reading Level	Correct Factor	Measurement	Limit	Over	Antenna Height	Table Degree
		MHz	dBuV	dB/m	dBuV/m	dBuV/m	dB	cm	degree
1	*	4904.000	51.24	-1.41	49.83	74.00	-24.17	peak	

**Radiated Emission**

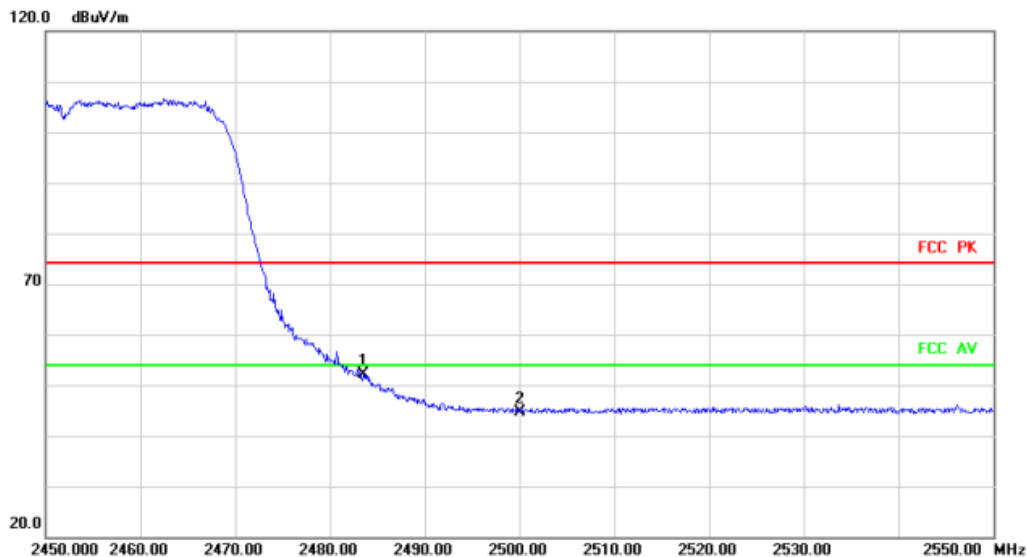

No.	Mk.	Freq.	Reading Level	Correct Factor	Measurement	Limit	Over	Antenna Height	Table Degree
		MHz	dBuV	dB/m	dBuV/m	dBuV/m	dB	cm	degree
1	*	2483.500	50.95	1.09	52.04	74.00	-21.96	peak	
2		2500.000	43.36	1.22	44.58	74.00	-29.42	peak	

### HORIZONTAL

#### Radiated Emission

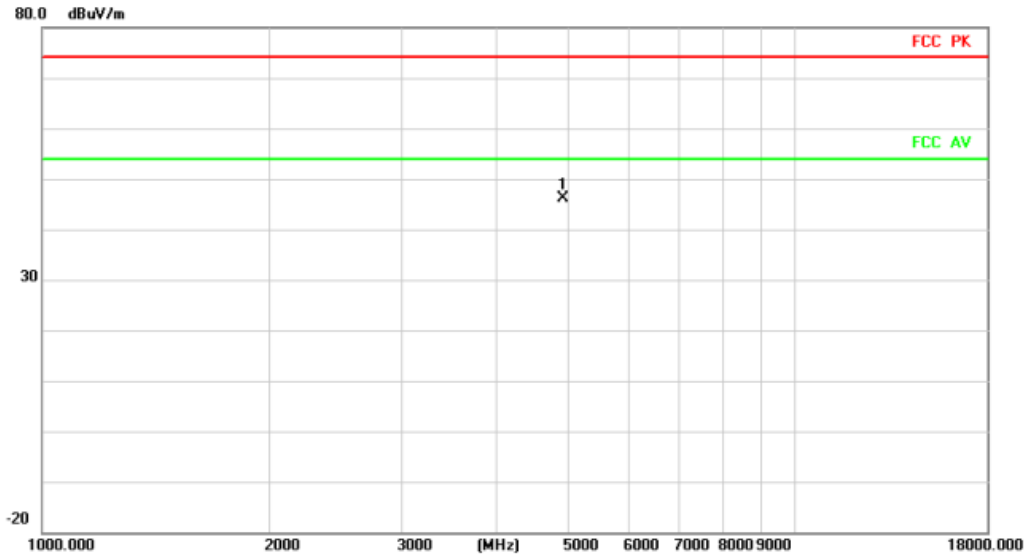

No.	Mk.	Freq.	Reading Level	Correct Factor	Measurement	Limit	Over	Antenna Height	Table Degree	
		MHz	dBuV	dB/m	dBuV/m	dBuV/m	dB	cm	degree	Comment
1	*	4904.000	47.64	-1.41	46.23	74.00	-27.77			peak

#### Radiated Emission

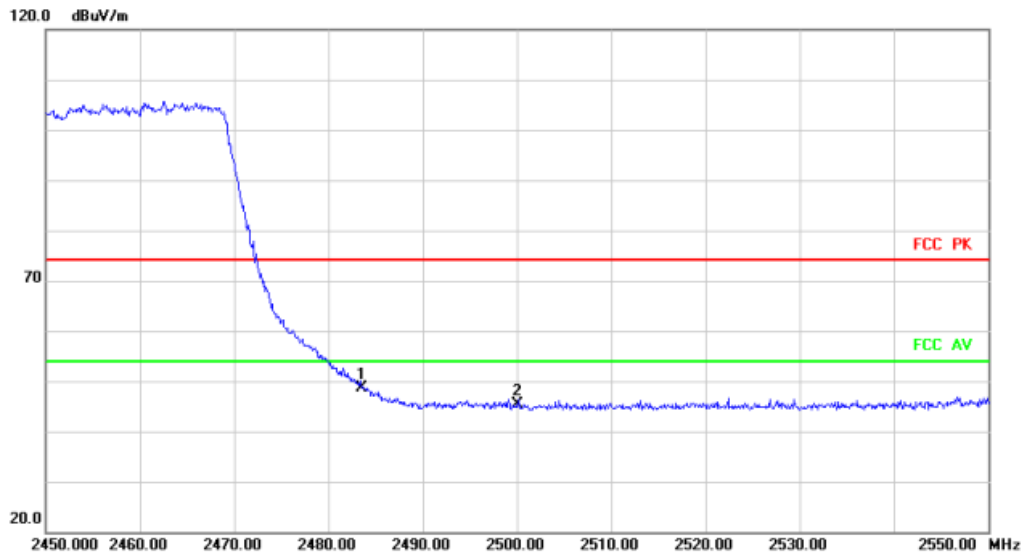

No.	Mk.	Freq.	Reading Level	Correct Factor	Measurement	Limit	Over	Antenna Height	Table Degree	
		MHz	dBuV	dB/m	dBuV/m	dBuV/m	dB	cm	degree	Comment
1	*	2483.500	47.60	1.09	48.69	74.00	-25.31			peak
2		2500.000	44.20	1.22	45.42	74.00	-28.58			peak

Above 1G (1GHz~18GHz)

Test mode: 11AX20MIMO

Test Channel:1

VERTICAL

**Radiated Emission**

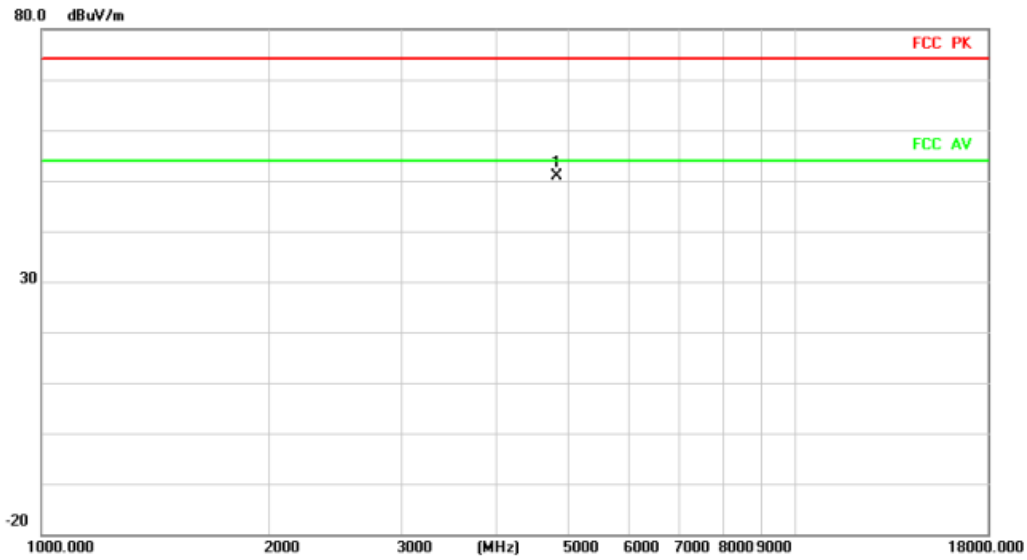

No.	Mk.	Freq.	Reading Level	Correct Factor	Measurement	Limit	Over	Antenna Height	Table Degree
		MHz	dBuV	dB/m	dBuV/m	dBuV/m	dB	cm	degree
1	*	4824.000	52.72	-1.88	50.84	74.00	-23.16	peak	

**Radiated Emission**

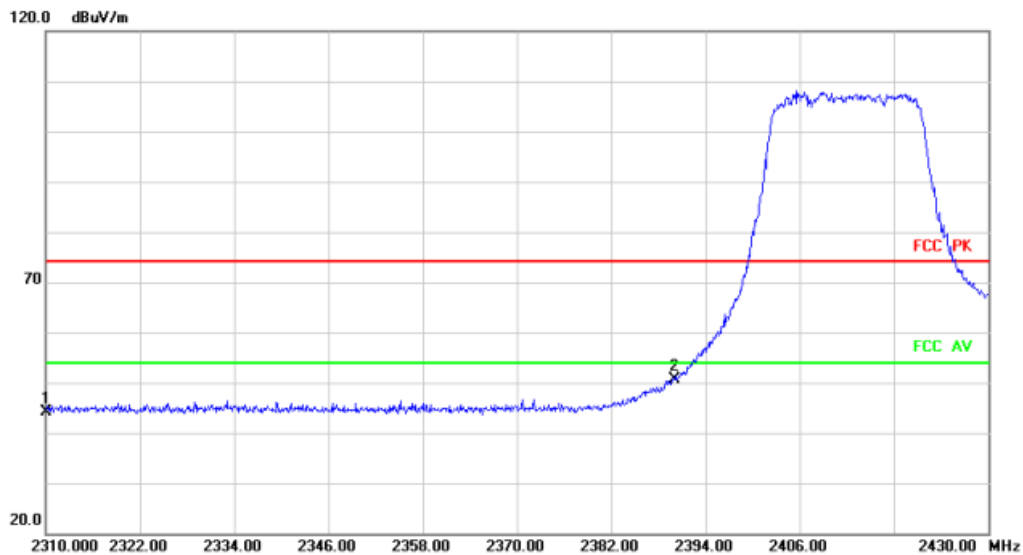

No.	Mk.	Freq.	Reading Level	Correct Factor	Measurement	Limit	Over	Antenna Height	Table Degree
		MHz	dBuV	dB/m	dBuV/m	dBuV/m	dB	cm	degree
1		2310.000	43.85	0.19	44.04	74.00	-29.96	peak	
2	*	2390.000	50.22	0.41	50.63	74.00	-23.37	peak	

## HORIZONTAL

### Radiated Emission

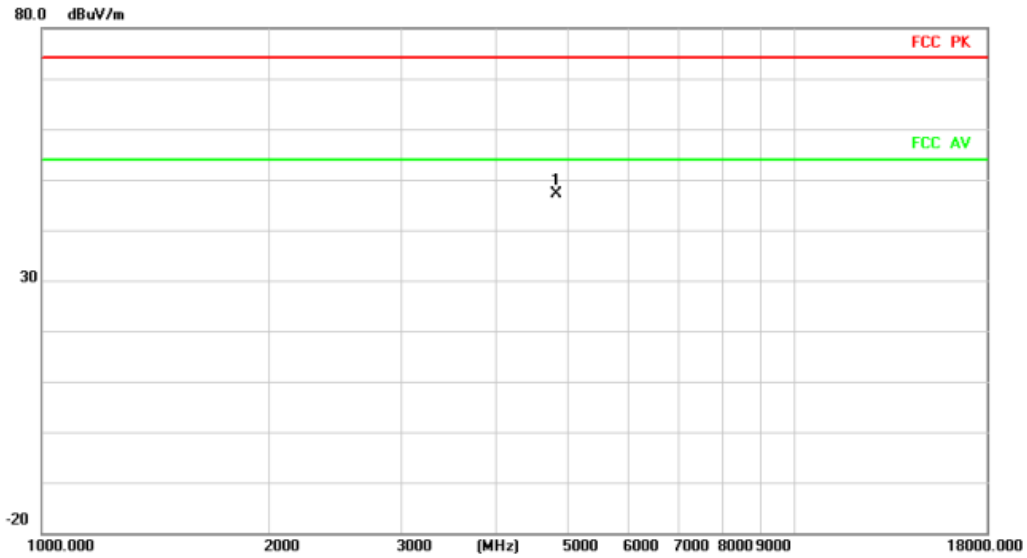

No.	Mk.	Freq.	Reading Level	Correct Factor	Measurement	Limit	Over	Antenna Height	Table Degree	Comment
		MHz	dBuV	dB/m	dBuV/m	dBuV/m	dB	cm	degree	
1	*	4824.000	49.03	-1.88	47.15	74.00	-26.85	peak		

### Radiated Emission

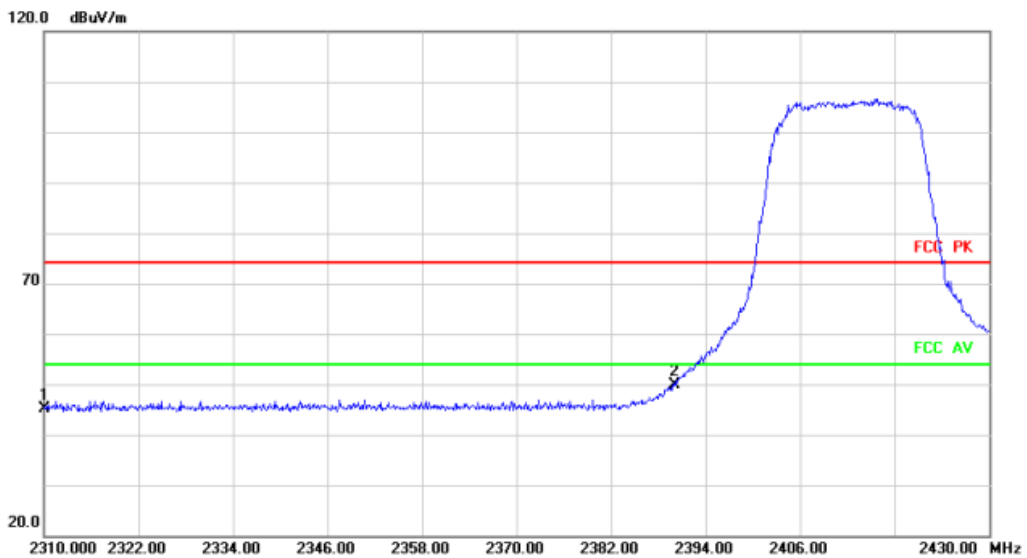

No.	Mk.	Freq.	Reading Level	Correct Factor	Measurement	Limit	Over	Antenna Height	Table Degree	Comment
		MHz	dBuV	dB/m	dBuV/m	dBuV/m	dB	cm	degree	
1		2310.000	44.83	0.19	45.02	74.00	-28.98	peak		
2	*	2390.000	49.48	0.41	49.89	74.00	-24.11	peak		

Above 1G (1GHz~18GHz)

Test mode: 11AX20MIMO

Test Channel: 6

VERTICAL

Radiated Emission

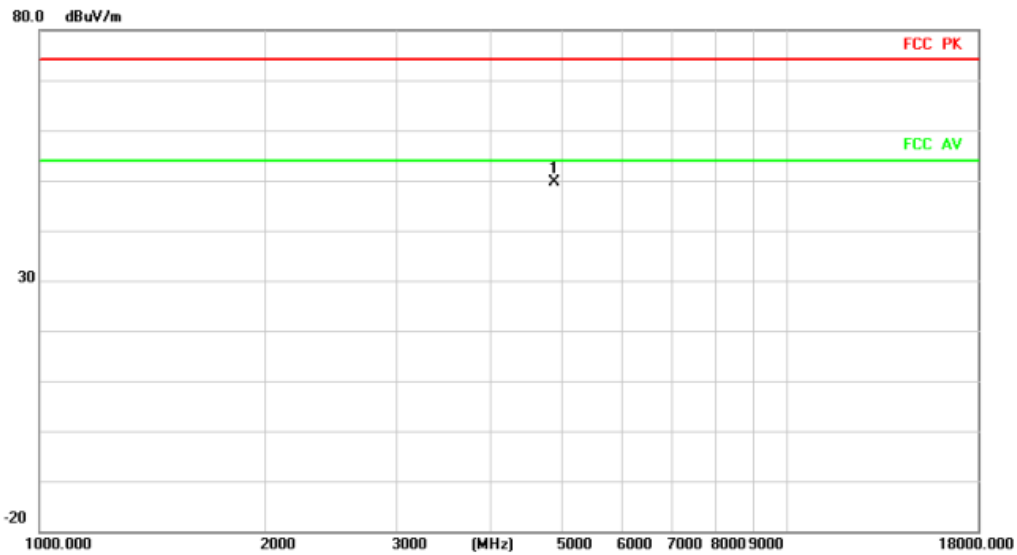

No.	Mk.	Freq.	Reading Level	Correct Factor	Measurement	Limit	Over	Antenna Height	Table Degree	
		MHz	dBuV	dB/m	dBuV/m	dBuV/m	dB	cm	degree	Comment
1	*	4874.000	51.16	-1.59	49.57	74.00	-24.43	peak		

HORIZONTAL

Radiated Emission

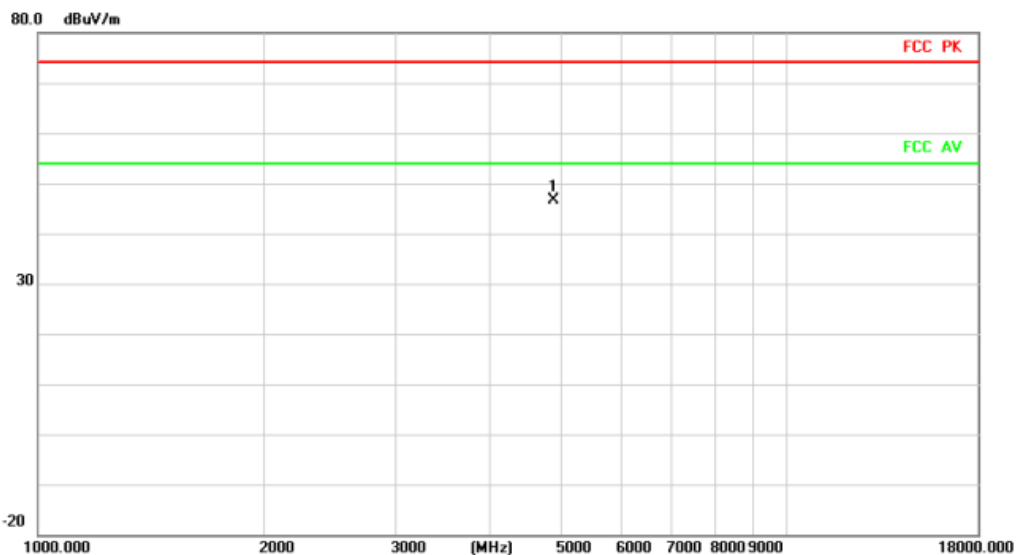

No.	Mk.	Freq.	Reading Level	Correct Factor	Measurement	Limit	Over	Antenna Height	Table Degree	
		MHz	dBuV	dB/m	dBuV/m	dBuV/m	dB	cm	degree	Comment
1	*	4874.000	48.11	-1.59	46.52	74.00	-27.48	peak		

Above 1G (1GHz~18GHz)

Test mode: 11AX20MIMO

Test Channel:11

VERTICAL

**Radiated Emission**

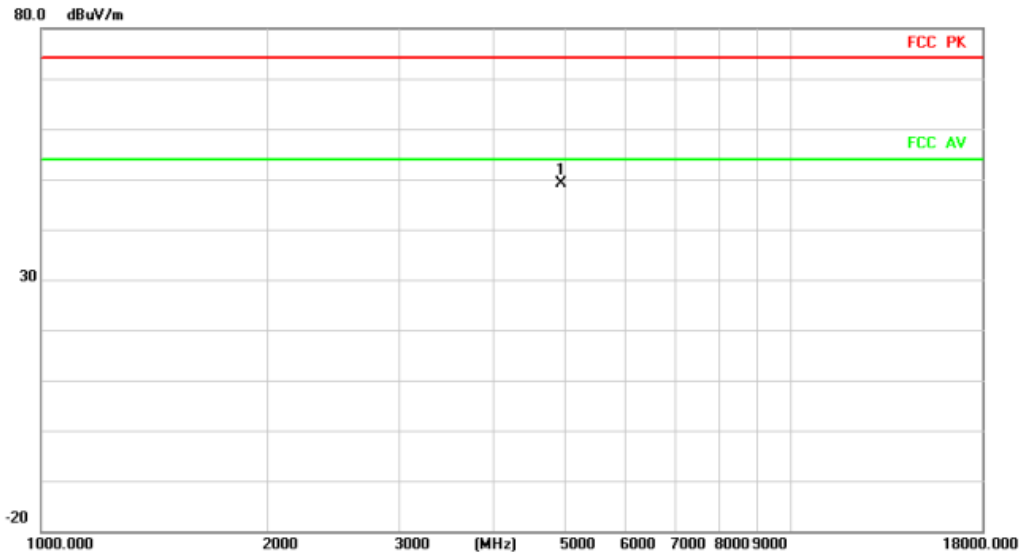

No.	Mk.	Freq.	Reading Level	Correct Factor	Measurement	Limit	Over	Antenna Height	Table Degree
		MHz	dBuV	dB/m	dBuV/m	dBuV/m	dB	cm	degree
1	*	4924.000	50.43	-1.29	49.14	74.00	-24.86	peak	

**Radiated Emission**

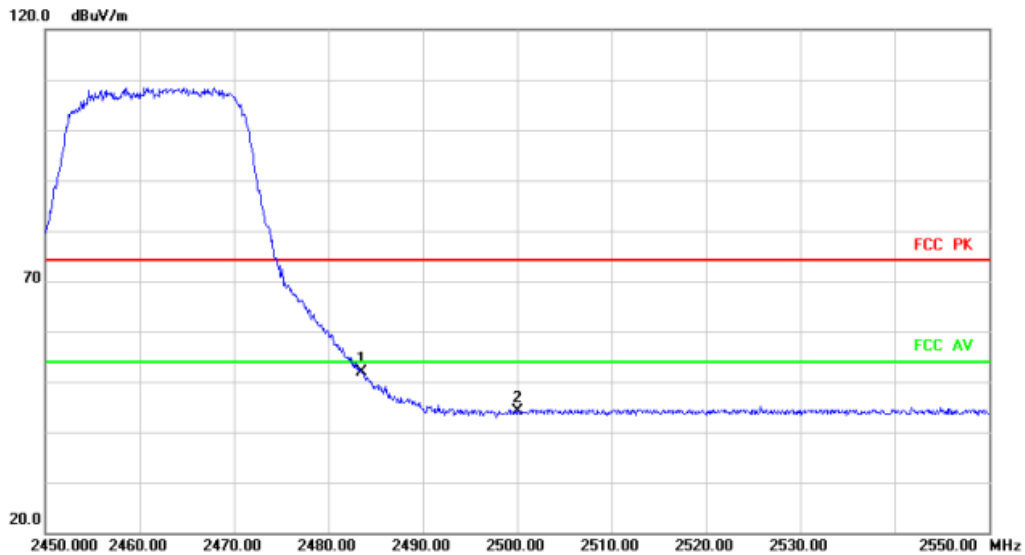

No.	Mk.	Freq.	Reading Level	Correct Factor	Measurement	Limit	Over	Antenna Height	Table Degree
		MHz	dBuV	dB/m	dBuV/m	dBuV/m	dB	cm	degree
1	*	2483.500	50.81	1.09	51.90	74.00	-22.10	peak	
2		2500.000	42.79	1.22	44.01	74.00	-29.99	peak	

### HORIZONTALA

#### Radiated Emission

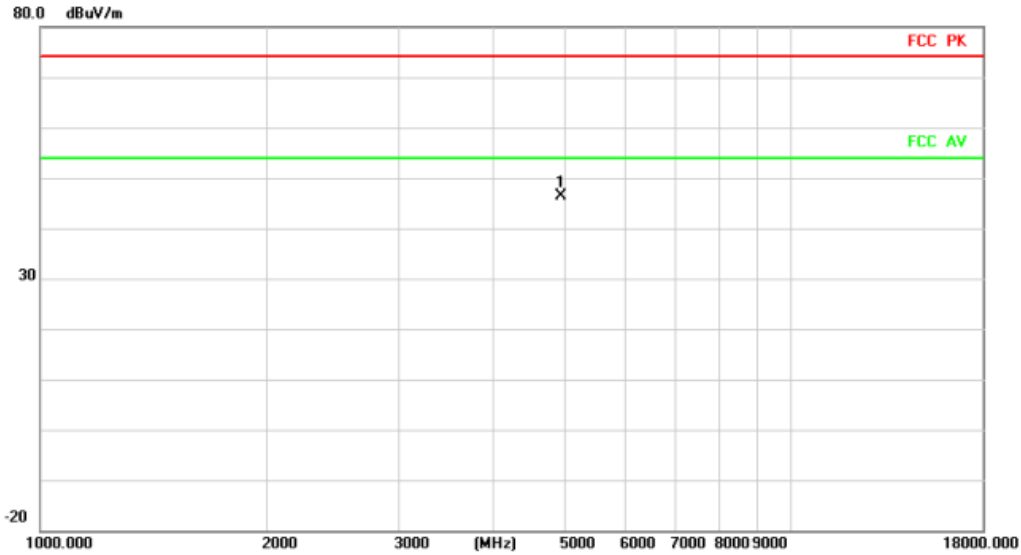

No.	Mk.	Freq.	Reading Level	Correct Factor	Measurement	Limit	Over	Antenna Height	Table Degree	
		MHz	dBuV	dB/m	dBuV/m	dBuV/m	dB	cm	degree	Comment
1	*	4924.000	47.63	-1.29	46.34	74.00	-27.66	peak		

#### Radiated Emission

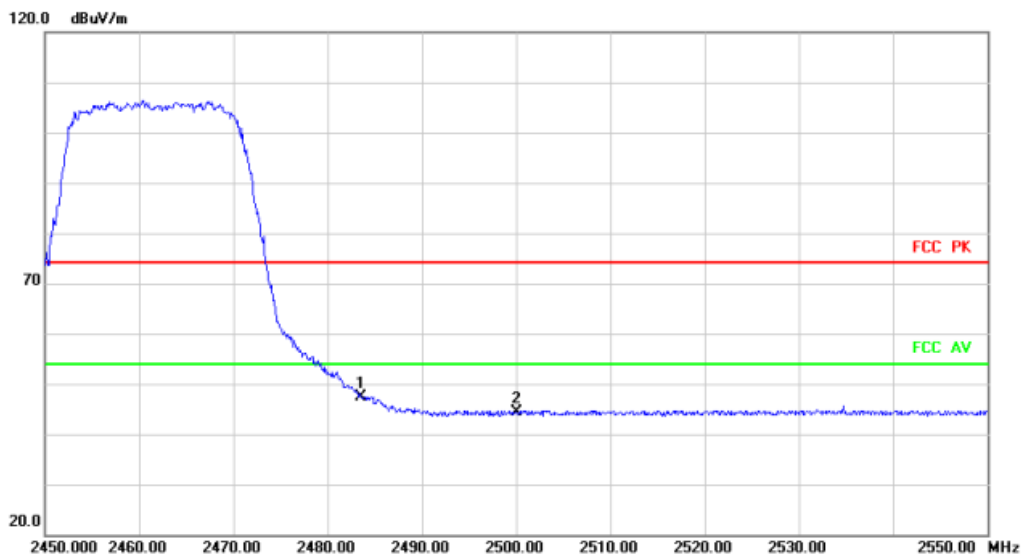

No.	Mk.	Freq.	Reading Level	Correct Factor	Measurement	Limit	Over	Antenna Height	Table Degree	
		MHz	dBuV	dB/m	dBuV/m	dBuV/m	dB	cm	degree	Comment
1	*	2483.500	46.19	1.09	47.28	74.00	-26.72	peak		
2		2500.000	43.27	1.22	44.49	74.00	-29.51	peak		

Above 1G (1GHz~18GHz)

Test mode: 11AX40MIMO

Test Channel:3

VERTICAL

**Radiated Emission**

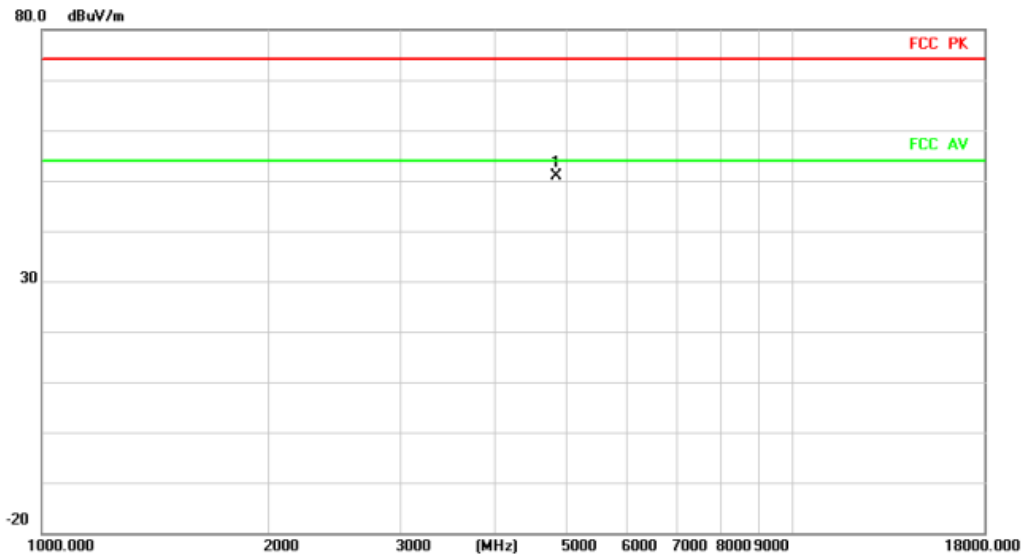

No.	Mk.	Freq.	Reading Level	Correct Factor	Measurement	Limit	Over	Antenna Height	Table Degree	
		MHz	dBuV	dB/m	dBuV/m	dBuV/m	dB	cm	degree	Comment
1	*	4844.000	52.54	-1.77	50.77	74.00	-23.23	peak		

**Radiated Emission**

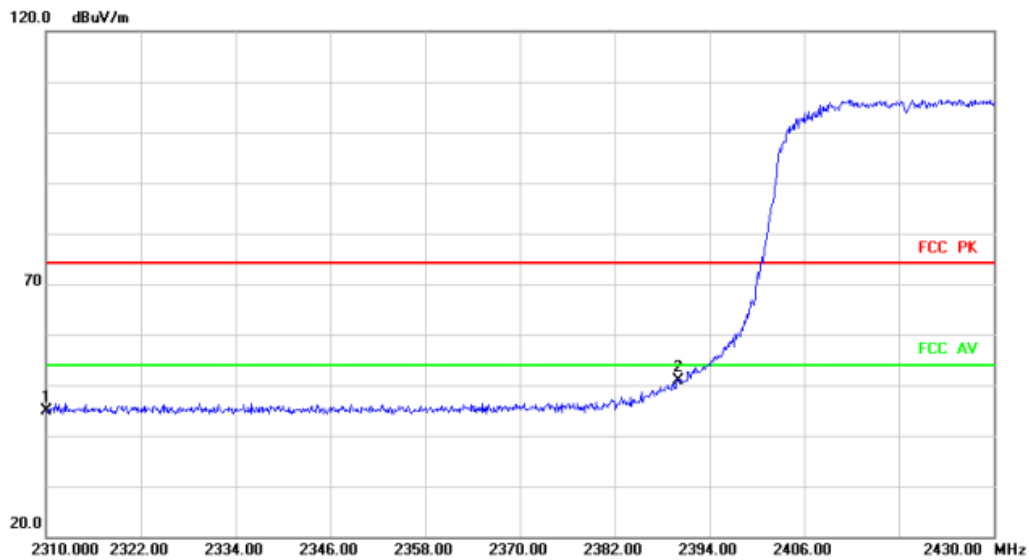

No.	Mk.	Freq.	Reading Level	Correct Factor	Measurement	Limit	Over	Antenna Height	Table Degree	
		MHz	dBuV	dB/m	dBuV/m	dBuV/m	dB	cm	degree	Comment
1		2310.000	44.81	0.19	45.00	74.00	-29.00	peak		
2	*	2390.000	50.43	0.41	50.84	74.00	-23.16	peak		



HORIZONTAL

Radiated Emission

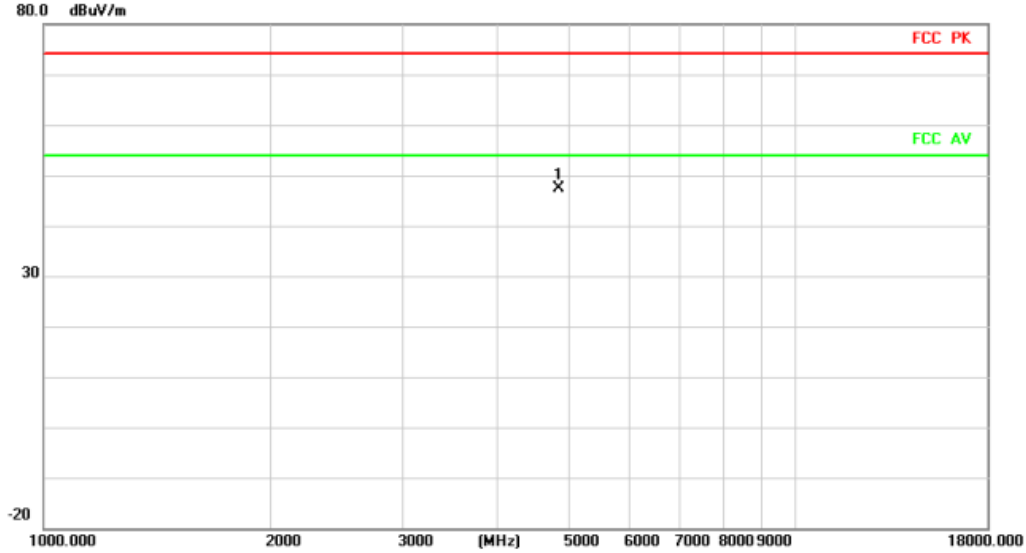

No.	Mk.	Freq.	Reading Level	Correct Factor	Measurement	Limit	Over	Antenna Height	Table Degree
		MHz	dBuV	dB/m	dBuV/m	dBuV/m	dB	cm	degree
1	*	4844.000	49.15	-1.77	47.38	74.00	-26.62	peak	

Radiated Emission

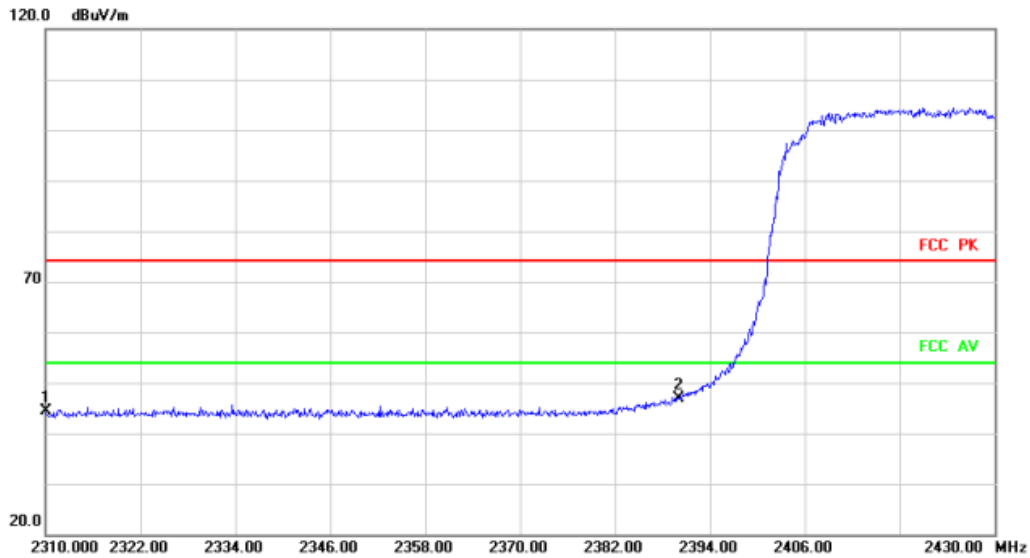

No.	Mk.	Freq.	Reading Level	Correct Factor	Measurement	Limit	Over	Antenna Height	Table Degree
		MHz	dBuV	dB/m	dBuV/m	dBuV/m	dB	cm	degree
1		2310.000	44.26	0.19	44.45	74.00	-29.55	peak	
2	*	2390.000	46.45	0.41	46.86	74.00	-27.14	peak	

Above 1G (1GHz~18GHz)

Test mode: 11AX40MIMO

Test Channel: 6

VERTICAL

**Radiated Emission**

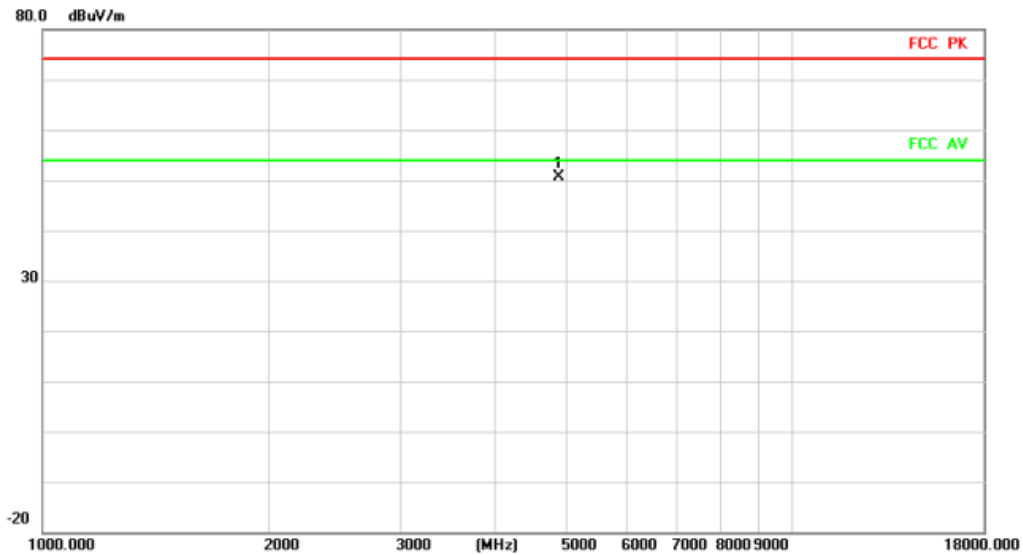

No.	Mk.	Freq.	Reading Level	Correct Factor	Measurement	Limit	Over	Antenna Height	Table Degree
		MHz	dBuV	dB/m	dBuV/m	dBuV/m	dB	cm	degree
1	*	4874.000	52.24	-1.59	50.65	74.00	-23.35	peak	

HORIZONTAL

**Radiated Emission**

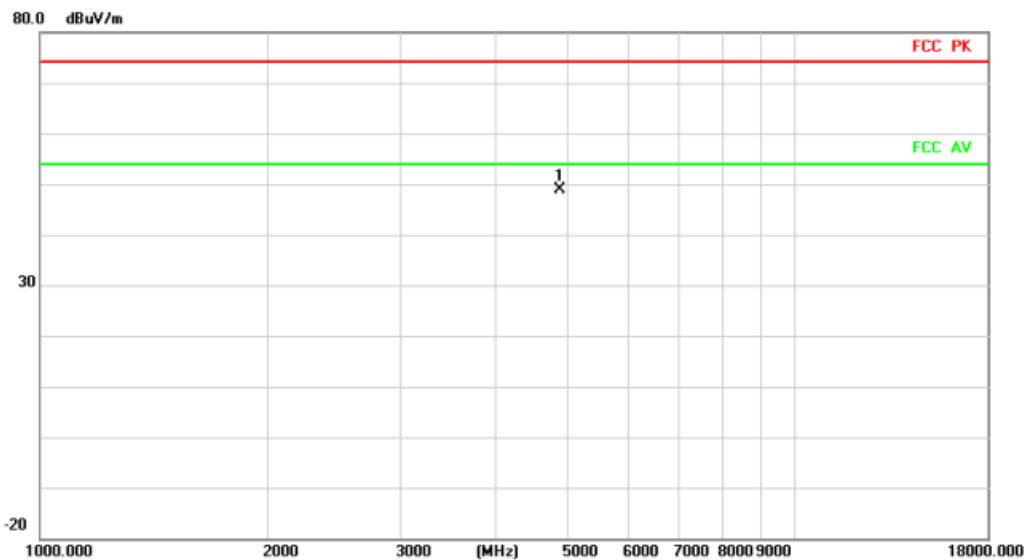

No.	Mk.	Freq.	Reading Level	Correct Factor	Measurement	Limit	Over	Antenna Height	Table Degree
		MHz	dBuV	dB/m	dBuV/m	dBuV/m	dB	cm	degree
1	*	4874.000	50.36	-1.59	48.77	74.00	-25.23	peak	

Above 1G (1GHz~18GHz)

Test mode: 11AX40MIMO

Test Channel:9

VERTICAL

**Radiated Emission**

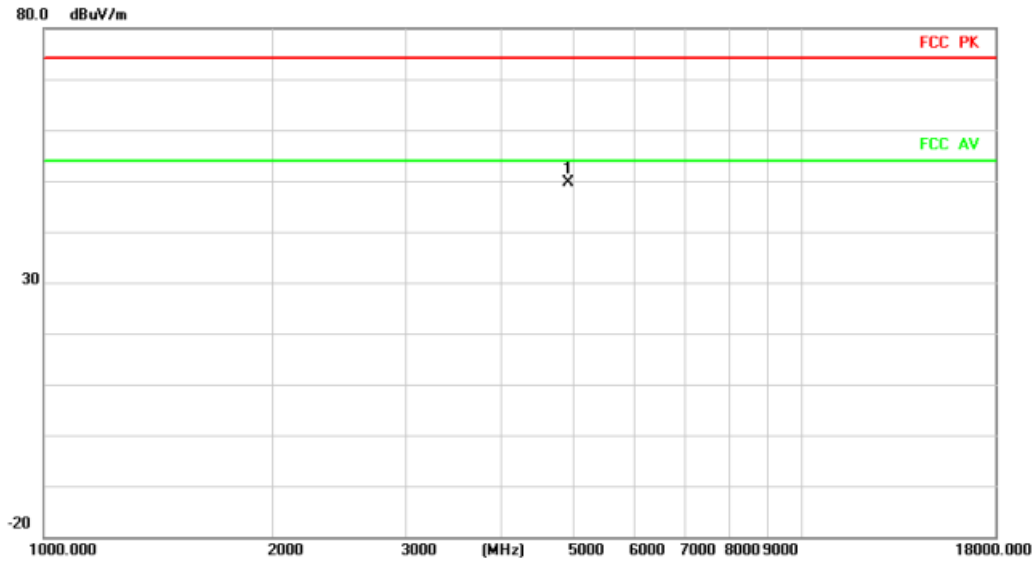

No.	Mk.	Freq.	Reading Level	Correct Factor	Measurement	Limit	Over	Antenna Height	Table Degree	
		MHz	dBuV	dB/m	dBuV/m	dBuV/m	dB	cm	degree	Comment
1	*	4904.000	50.96	-1.41	49.55	74.00	-24.45	peak		

**Radiated Emission**

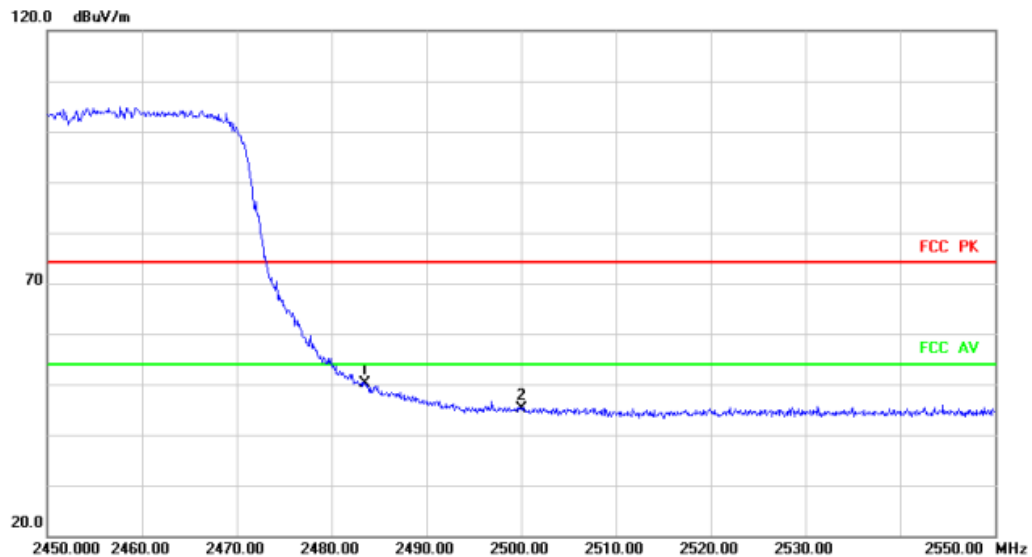

No.	Mk.	Freq.	Reading Level	Correct Factor	Measurement	Limit	Over	Antenna Height	Table Degree	
		MHz	dBuV	dB/m	dBuV/m	dBuV/m	dB	cm	degree	Comment
1	*	2483.500	48.99	1.09	50.08	74.00	-23.92	peak		
2		2500.000	43.88	1.22	45.10	74.00	-28.90	peak		

## HORIZONTALA

### Radiated Emission

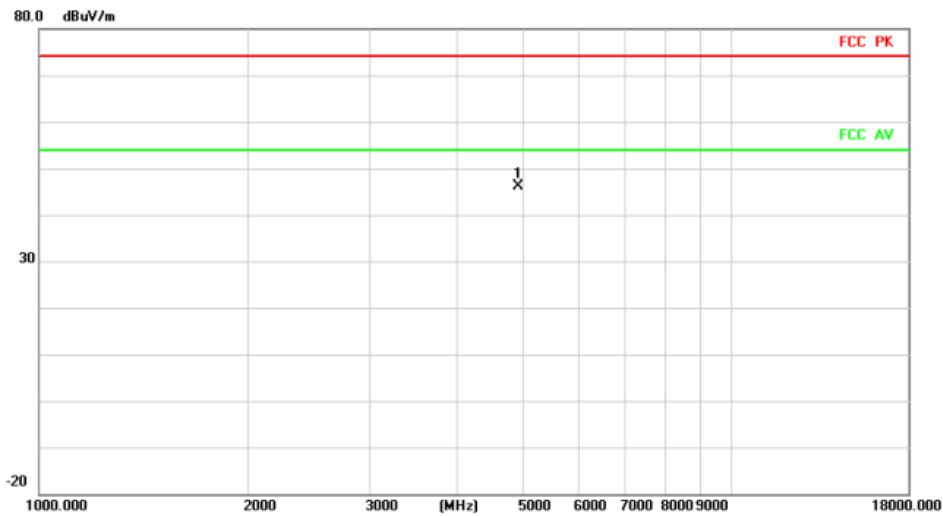

No.	Mk.	Freq.	Reading Level	Correct Factor	Measurement	Limit	Over	Antenna Height	Table Degree
		MHz	dBuV	dB/m	dBuV/m	dBuV/m	dB	cm	degree
1	*	4904.000	47.58	-1.41	46.17	74.00	-27.83	peak	

### Radiated Emission

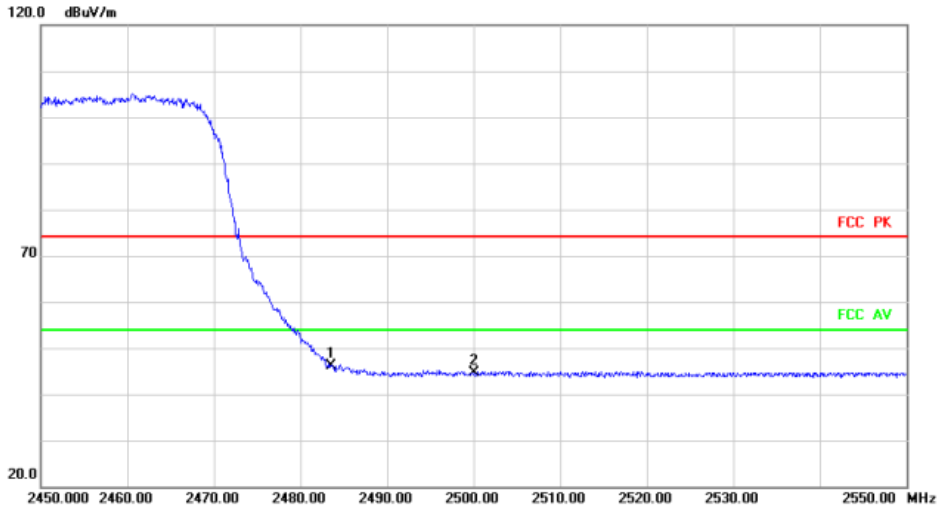

No.	Mk.	Freq.	Reading Level	Correct Factor	Measurement	Limit	Over	Antenna Height	Table Degree
		MHz	dBuV	dB/m	dBuV/m	dBuV/m	dB	cm	degree
1	*	2483.500	45.14	1.09	46.23	74.00	-27.77	peak	
2		2500.000	43.48	1.22	44.70	74.00	-29.30	peak	

The high frequency, which started from 18GHz to 25GHz, was pre-scanned and the result which was 20dB lower than the limit line was not recorded in this report.

### 3.3 Spurious Emission at Antenna Port

#### 3.3.1 Limit

In any 100 kHz bandwidth outside the frequency band in which the spread spectrum or digitally modulated intentional radiator is operating, the radio frequency power that is produced by the intentional radiator shall be at least 20 dB below that in the 100 kHz bandwidth within the band that contains the highest level of the desired power, based on either an RF conducted or a radiated measurement, provided the transmitter demonstrates compliance with the peak Output Power limits. If the transmitter complies with the Output Power limits based on the use of RMS averaging over a time interval, as permitted under paragraph (b)(3) of this section, the attenuation required under this paragraph shall be 30 dB instead of 20 dB. Attenuation below the general limits specified in Section 15.209(a) is not required. In addition, radiated emissions which fall in the restricted bands, as defined in Section 15.205(a), must also comply with the radiated emission limits specified in Section 15.209(a) (see Section 15.205(c)).

#### 3.3.2 Test Procedure

Test Method	
●Conducted Measurement	○Radiated Measurement
Test Channels	
● Lowest, Middle and Highest Channel	○ Lowest and Highest Channel
Environmental conditions	
●Normal	○Normal and Extreme
Note:●:Test    ○:No Test	

a) The EUT was directly connected to the tonscond test system and antenna output port as show in the block diagram below.

b) Spectrum Setting as below:

Centre Frequency	The centre frequency of the channel under test
Spectrum Parameters	Setting
Start Frequency	30 MHz
Stop Frequency	26.5 GHz
RBW	100 kHz
VBW	300 kHz
Detector	Peak
Trace	Max Hold
Sweep Time	Auto

### 3.3.3 Test Setup

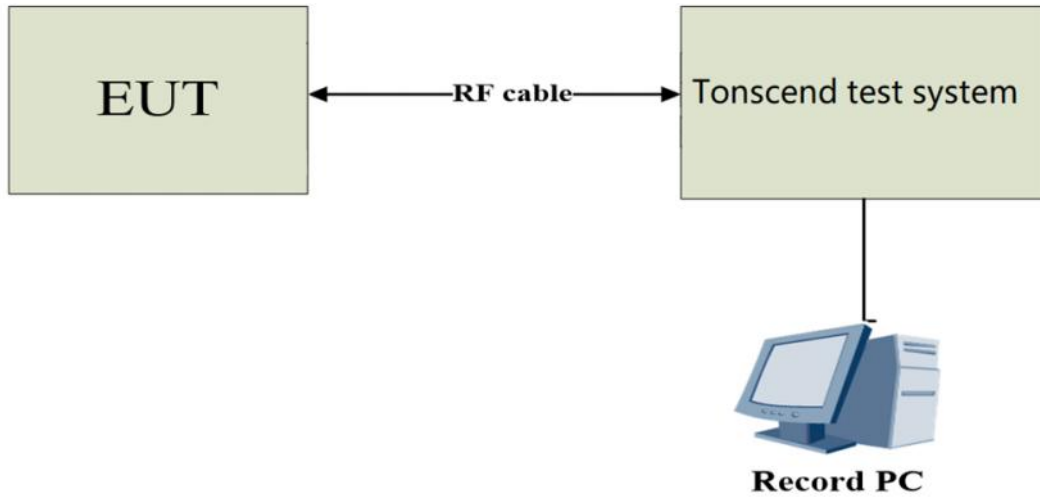

### 3.3.4 The Result

#### Conducted Spurious Emission

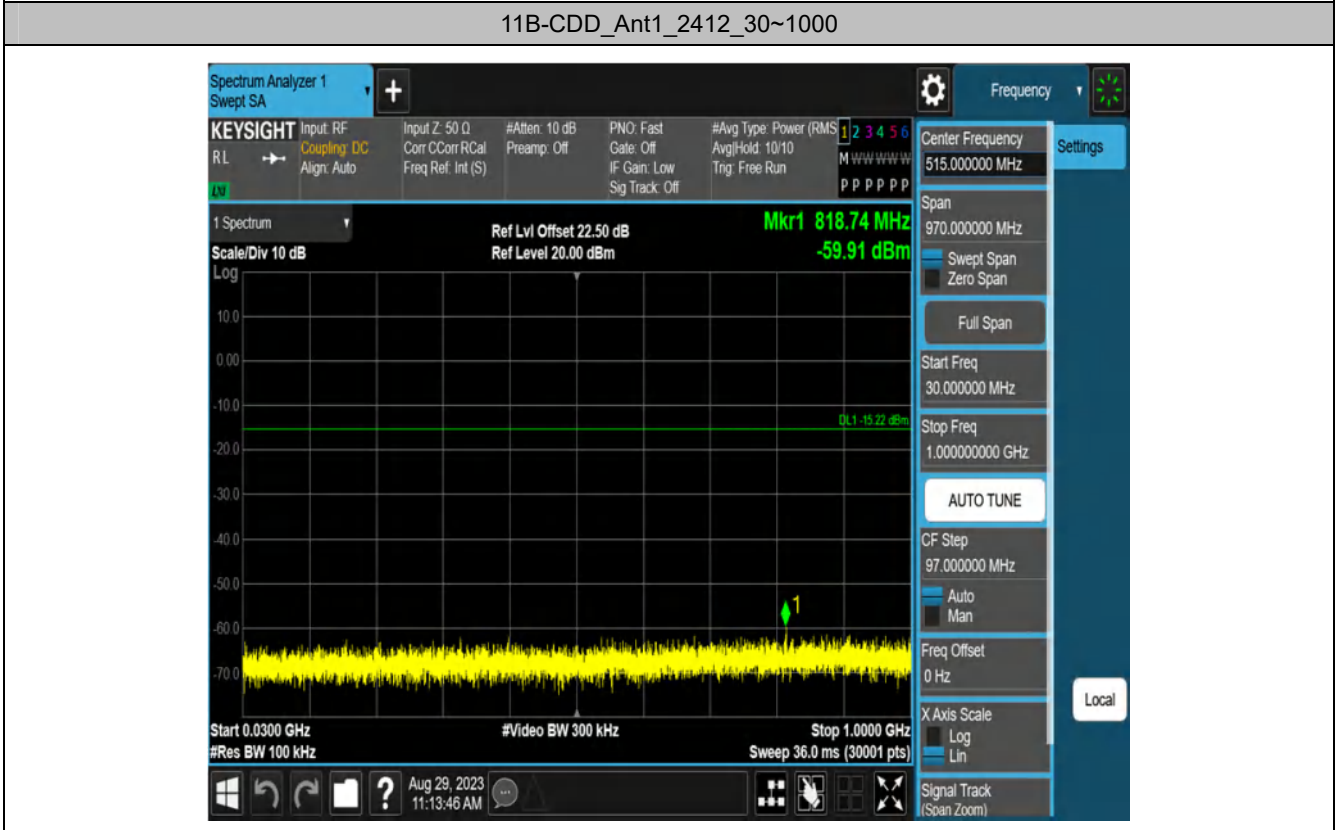
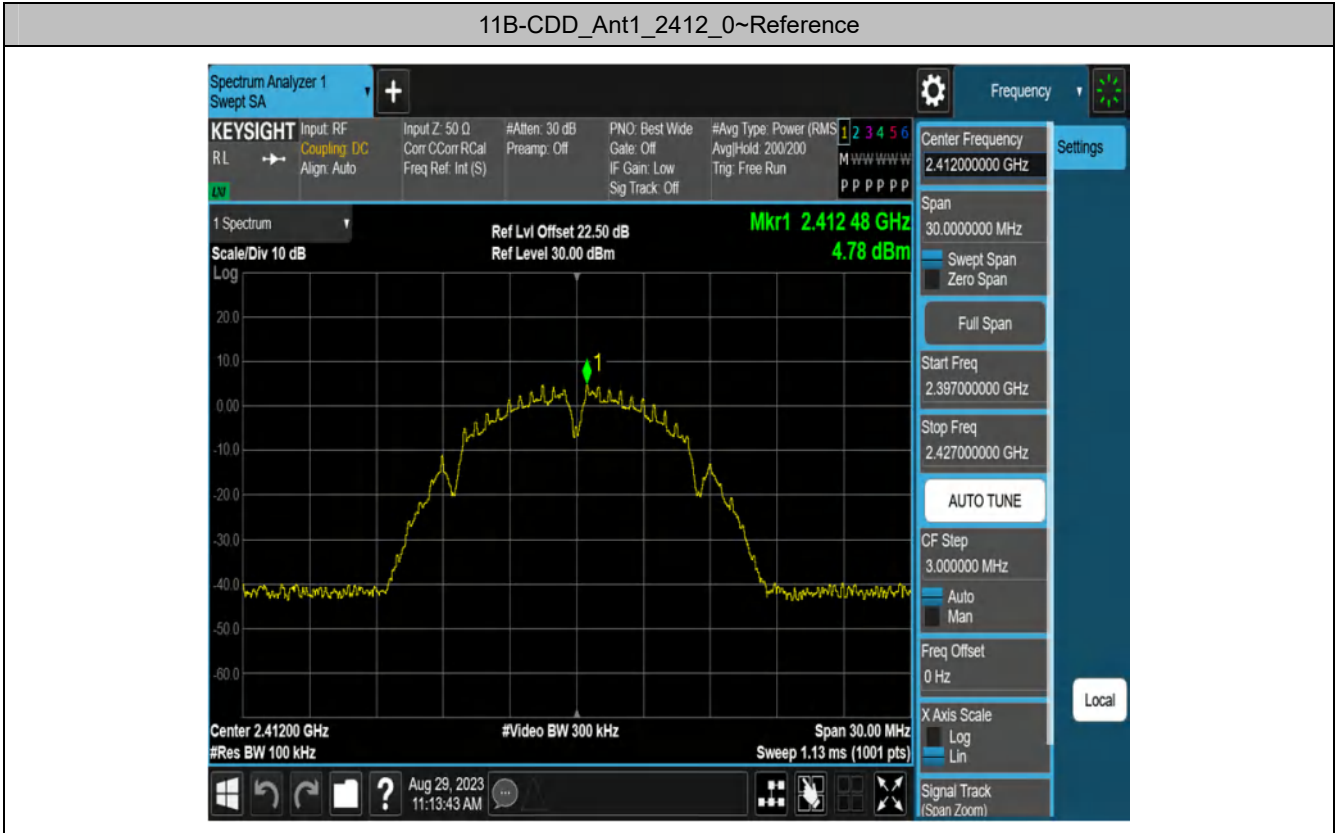

11B-CDD\_Ant1\_2412\_1000~26500



11B-CDD\_Ant2\_2412\_0~Reference





11B-CDD\_Ant2\_2412\_30~1000

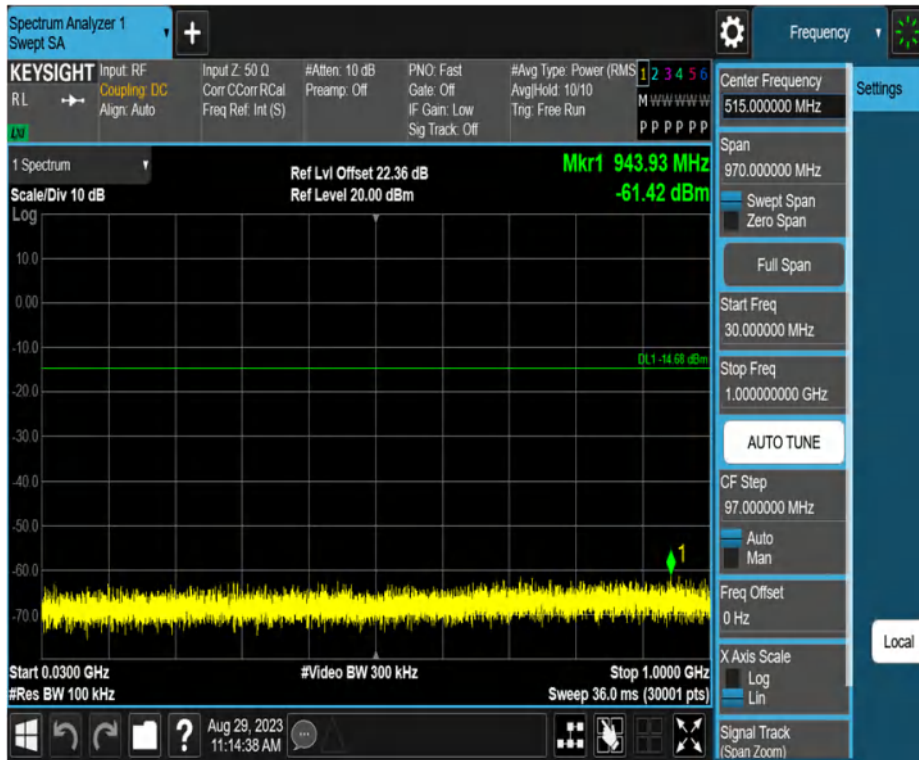

11B-CDD\_Ant2\_2412\_1000~26500



11B-CDD\_Ant1\_2437\_0~Reference



11B-CDD\_Ant1\_2437\_30~1000

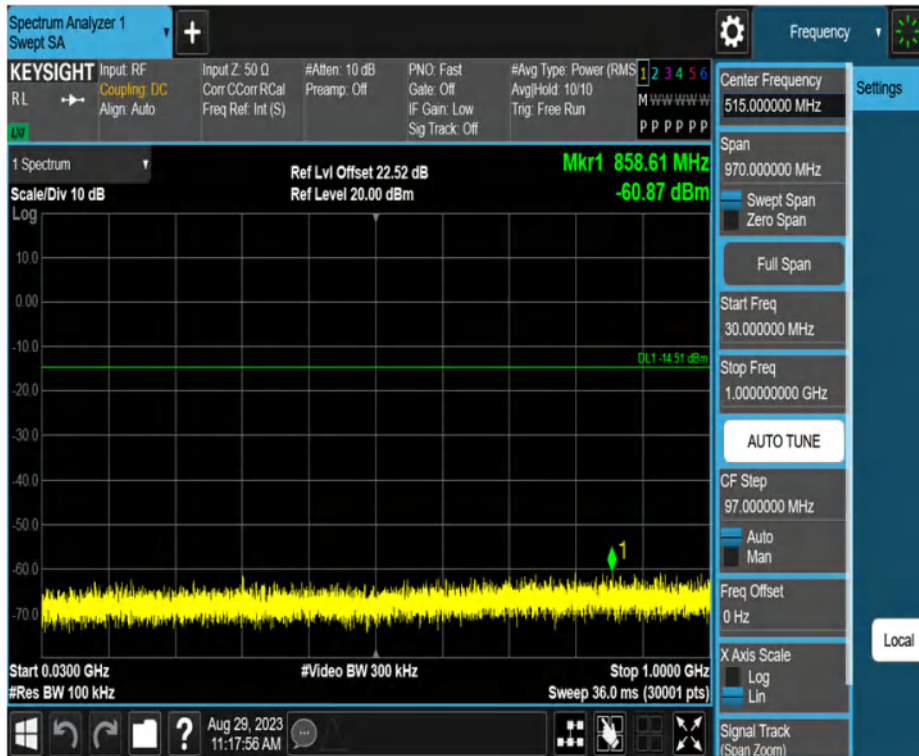

11B-CDD\_Ant1\_2437\_1000~26500

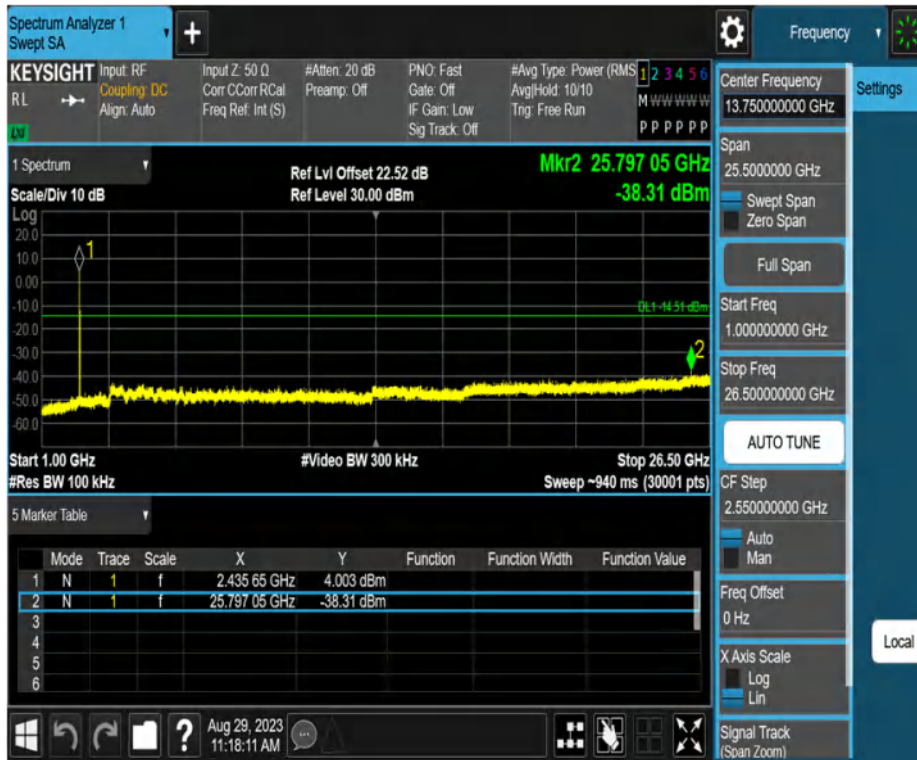

11B-CDD\_Ant2\_2437\_0~Reference



11B-CDD\_Ant2\_2437\_30~1000

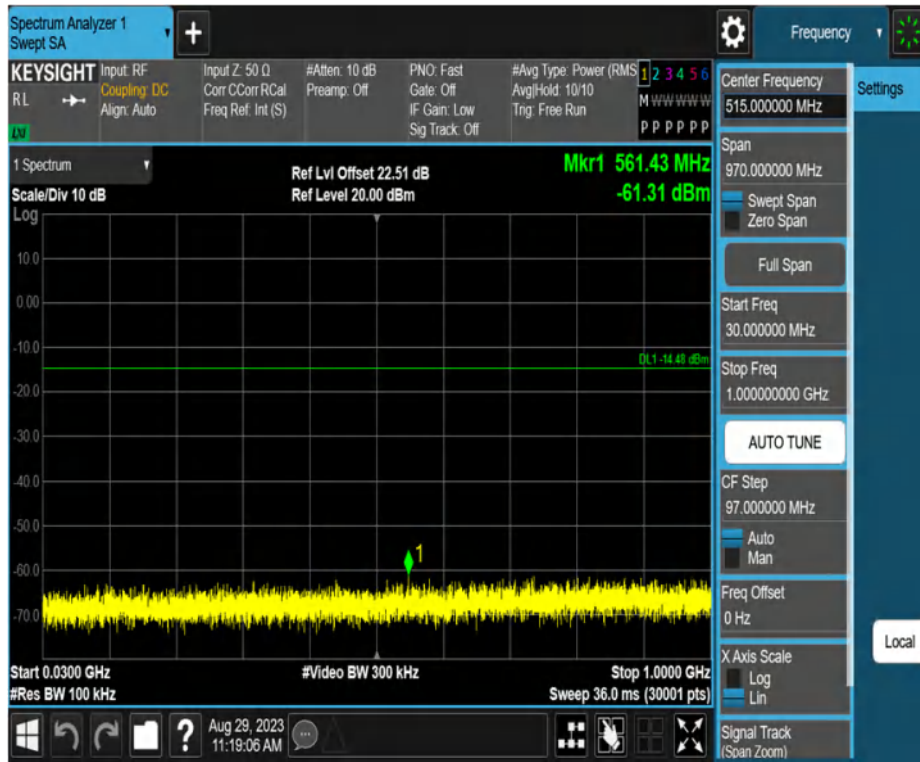

11B-CDD\_Ant2\_2437\_1000~26500



11B-CDD\_Ant1\_2462\_0~Reference

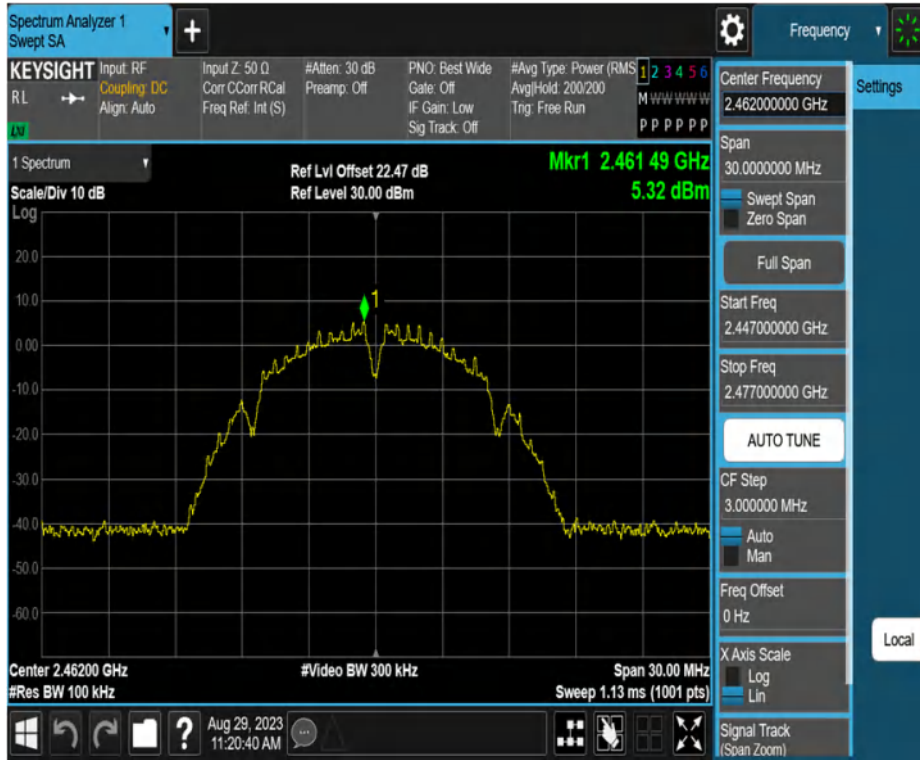

11B-CDD\_Ant1\_2462\_30~1000

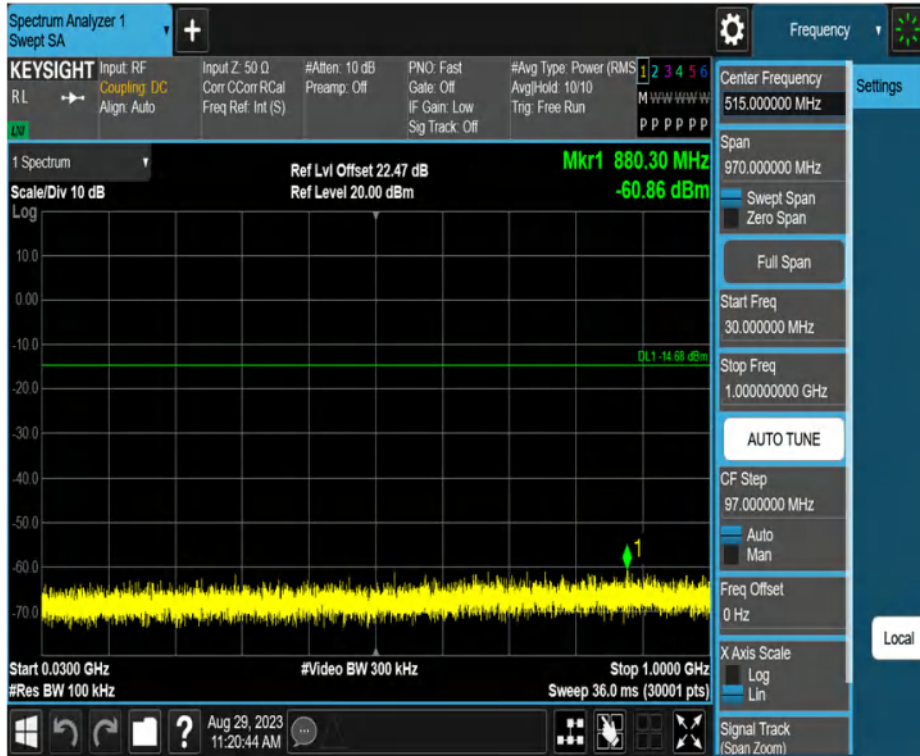

11B-CDD\_Ant1\_2462\_1000~26500



11B-CDD\_Ant2\_2462\_0~Reference



11B-CDD\_Ant2\_2462\_30~1000

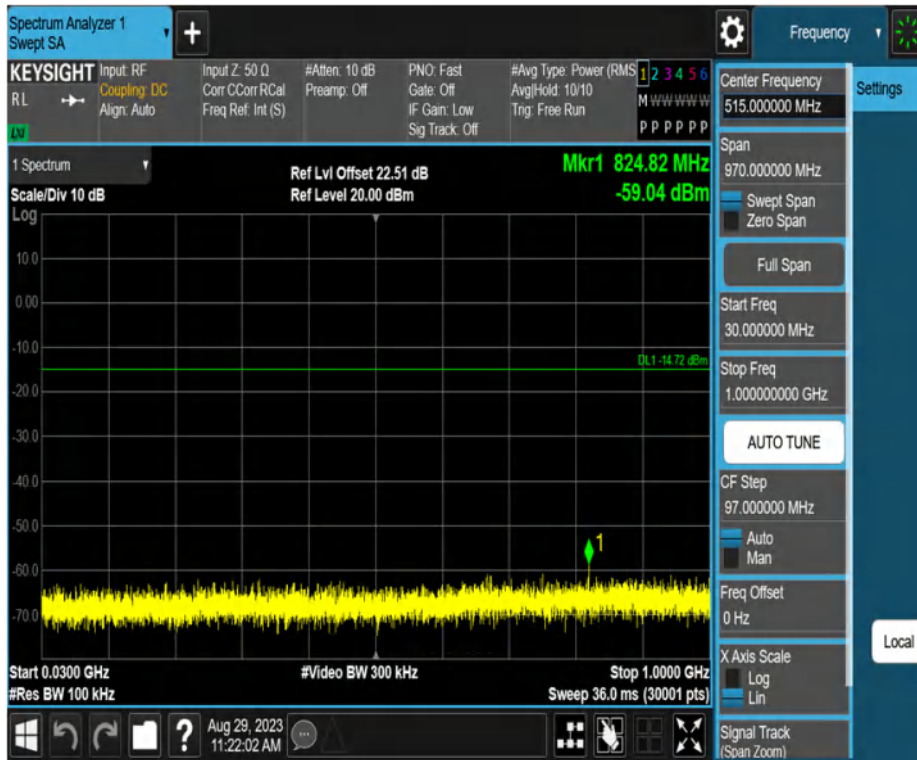

11B-CDD\_Ant2\_2462\_1000~26500



11G-CDD\_Ant1\_2412\_0~Reference



11G-CDD\_Ant1\_2412\_30~1000

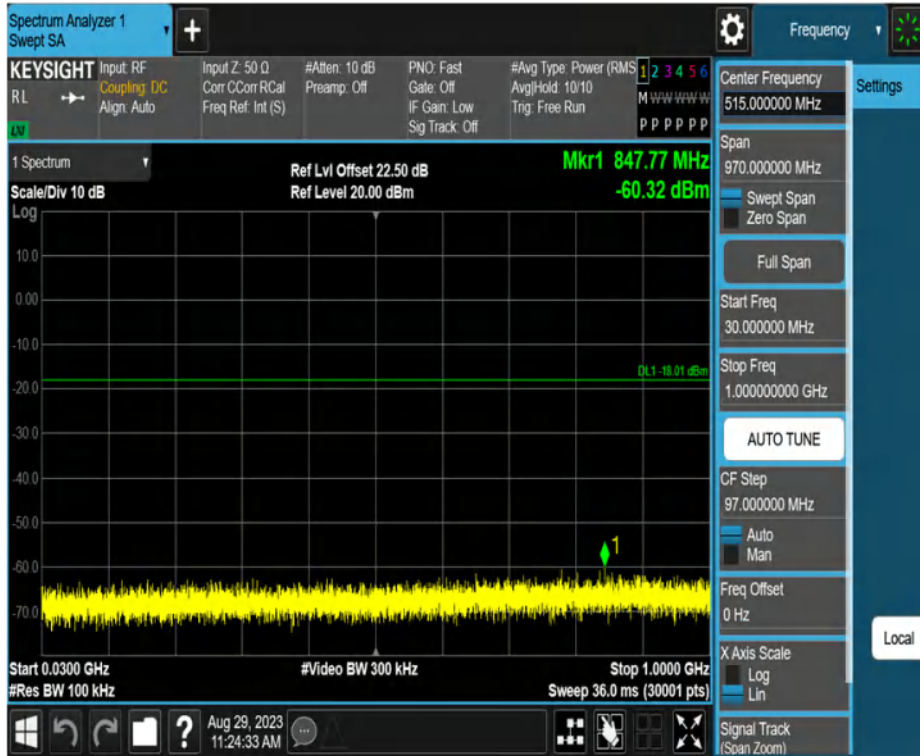



11G-CDD\_Ant1\_2412\_1000~26500



11G-CDD\_Ant2\_2412\_0~Reference

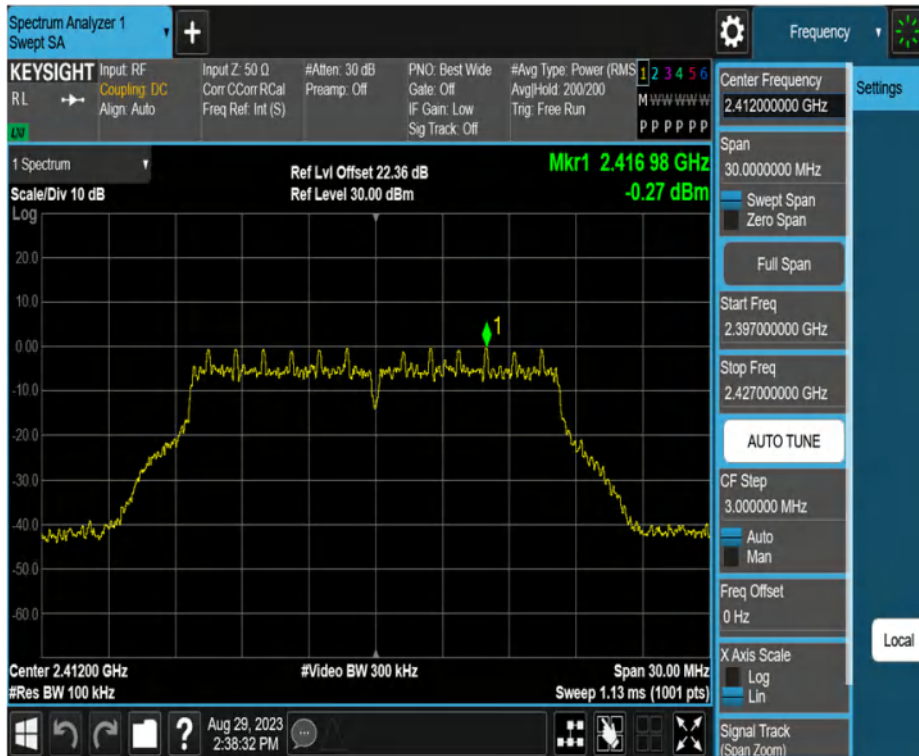

11G-CDD\_Ant2\_2412\_30~1000

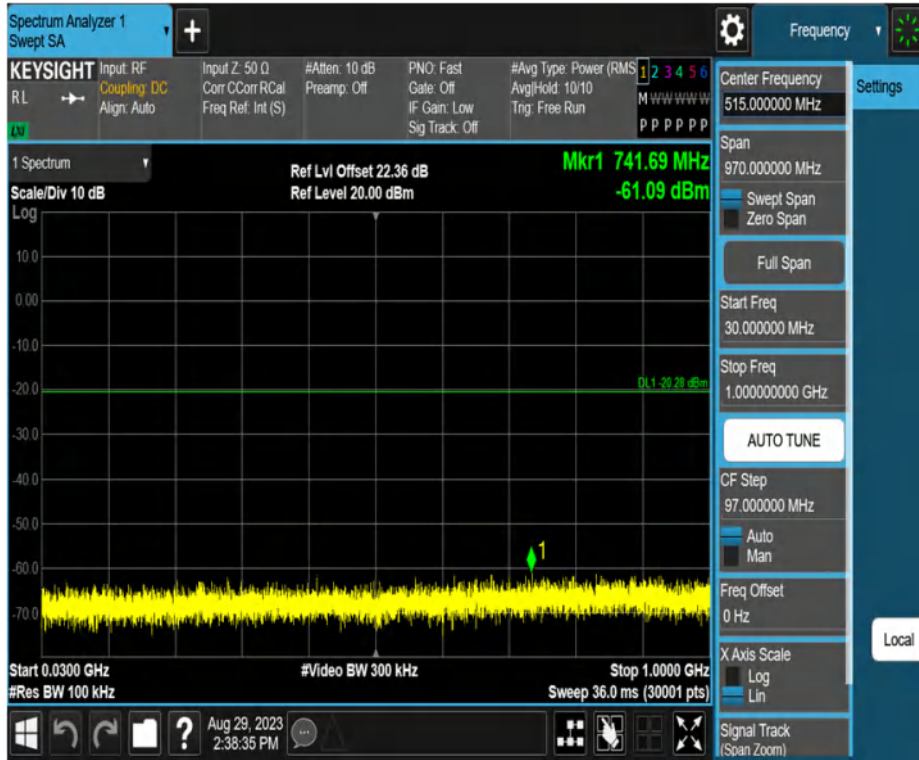

11G-CDD\_Ant2\_2412\_1000~26500

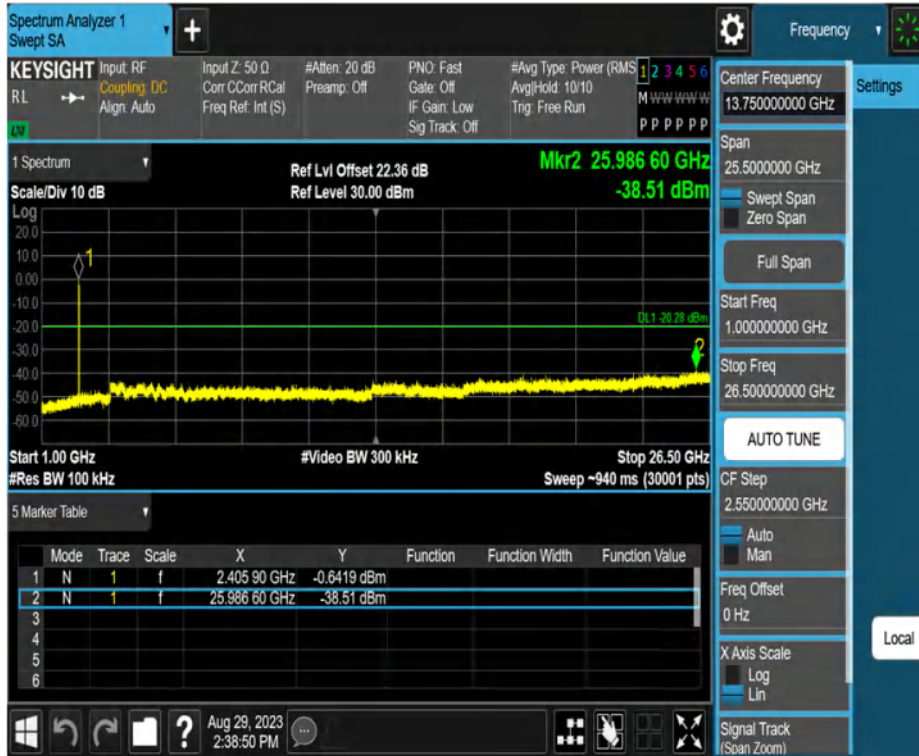

11G-CDD\_Ant1\_2437\_0~Reference



11G-CDD\_Ant1\_2437\_30~1000

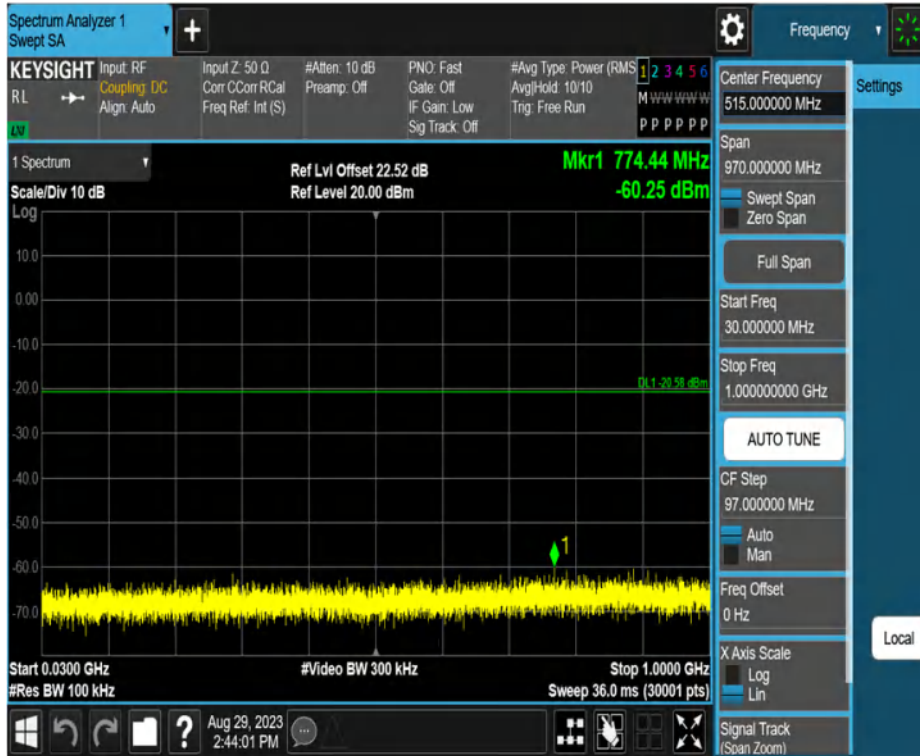

11G-CDD\_Ant1\_2437\_1000~26500



11G-CDD\_Ant2\_2437\_0~Reference

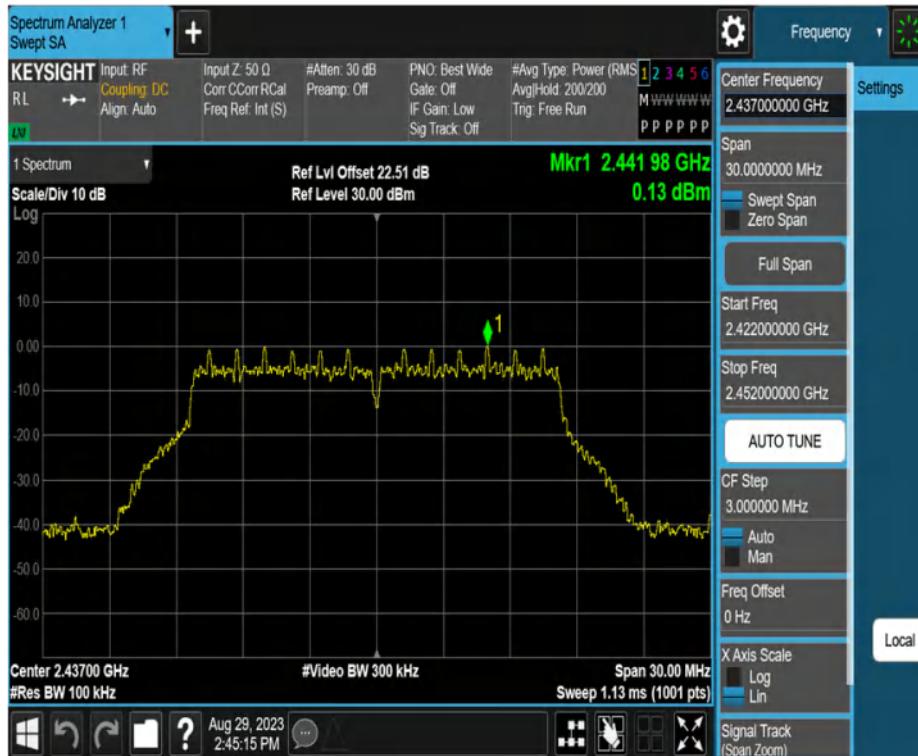

11G-CDD\_Ant2\_2437\_30~1000



11G-CDD\_Ant2\_2437\_1000~26500



11G-CDD\_Ant1\_2462\_0~Reference

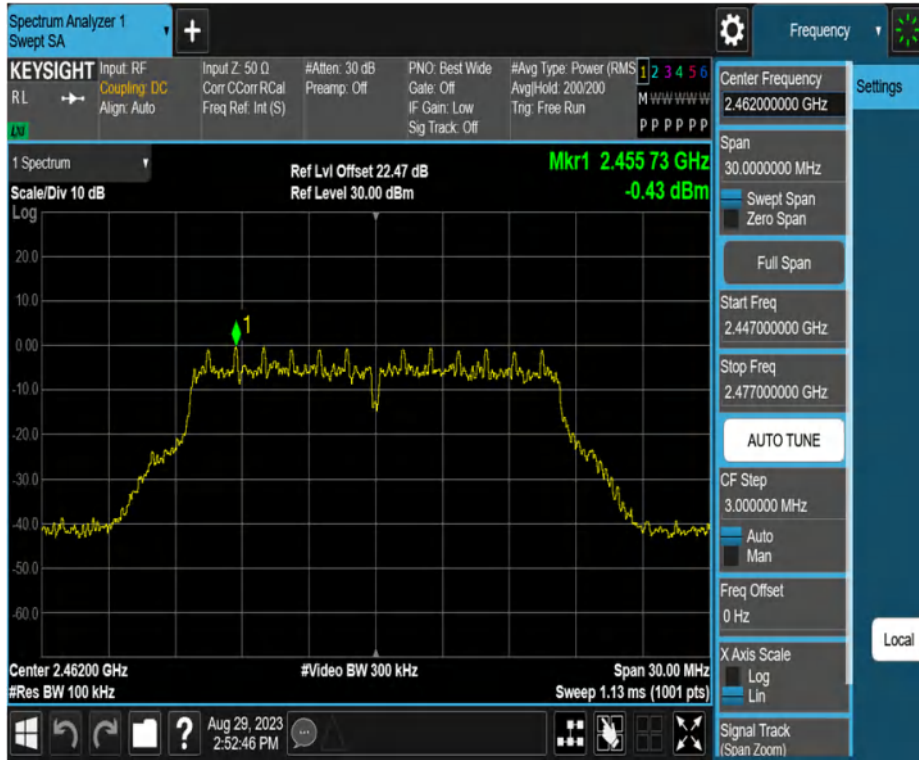

11G-CDD\_Ant1\_2462\_30~1000

