

# FCC CFR47 PART 22H, 24E, 27 CERTIFICATION TEST REPORT

## FCC ID: 2AT9T-3103

**Product:** Mobile Phone

**Trade Mark:** ulefone

**Model Number:** GQ3103

Power Armor 16 Pro, Power Armor 16, Power

**Family Model:** Armor 16S, Power Armor 16E, Power Armor 16P,  
Power Armor 16 Plus, Power Armor 16 Lite

**Report No.:** STR220705005006E

### Prepared for

Shenzhen Ulefone Technology Co., Ltd.

7A01, Building A, Block 1, Anhongji Tianyao Plaza, Longhua District,  
Shenzhen City, Guangdong Province China

### Prepared by

Shenzhen NTEK Testing Technology Co., Ltd.

1/F, Building E, Fenda Science Park, Sanwei Community, Xixiang Street  
Bao'an District, Shenzhen 518126 P.R. China

Tel. 400-800-6106, 0755-2320 0050, 0755-2320 0090

Website: <http://www.ntek.org.cn>

<b>TEST RESULT CERTIFICATION</b>	
<b>Applicant's name</b> .....	Shenzhen Ulefone Technology Co., Ltd.
<b>Address</b> .....	7A01, Building A, Block 1, Anhongji Tianyao Plaza, Longhua District, Shenzhen City, Guangdong Province China
<b>Manufacturer's Name</b> .....	Shenzhen Ulefone Technology Co., Ltd.
<b>Address</b> .....	7A01, Building A, Block 1, Anhongji Tianyao Plaza, Longhua District, Shenzhen City, Guangdong Province China
<b>Product name</b> .....	Mobile Phone
<b>Model and/or type reference</b> .....	GQ3103
<b>Family Model:</b>	Power Armor 16 Pro, Power Armor 16, Power Armor 16S, Power Armor 16E, Power Armor 16P, Power Armor 16 Plus, Power Armor 16 Lite
<b>Standards</b> .....	FCC CFR 47 Part 22H, Part 24E, Part 27
<b>Test procedure</b> .....	ANSI C63.26:2015 ANSI/TIA-603-E-2016

This device described above has been tested by NTEK, and the test results show that the equipment under test (EUT) is in compliance with the FCC requirements. And it is applicable only to the tested sample identified in the report.

This report shall not be reproduced except in full, without the written approval of NTEK, this document may be altered or revised by NTEK, personal only, and shall be noted in the revision of the document.

<b>Test Sample Number</b> .....:	T220705002R003
<b>Date of Test</b> .....	
<b>Date (s) of performance of tests</b> .....	Jul 06, 2022 ~ Aug 01, 2022
<b>Date of Issue</b> .....	Aug 04, 2022
<b>Test Result</b> .....	<b>Pass</b>

Testing Engineer :



(Allen Liu)

Authorized Signatory :



(Alex Li)

## TABLE OF CONTENTS

1.1 PRODUCT DESCRIPTION .....	5
1.2 RELATED SUBMITTAL(S) / GRANT (S) .....	7
1.3 TEST METHODOLOGY .....	7
1.4 TEST FACILITY .....	7
MEASUREMENT UNCERTAINTY .....	7
1.5 SPECIAL ACCESSORIES.....	7
1.6 WORST-CASE CONFIGURATION AND MODE.....	8
1.6 SUMMARY OF TEST RESULTS .....	8
2. SYSTEM TEST CONFIGURATION .....	10
2.1 EUT CONFIGURATION.....	10
2.2 EUT EXERCISE .....	10
2.3 CONFIGURATION OF EUT SYSTEM.....	10
2.4 TEST SETUP .....	11
3.TEST AND MEASUREMENT EQUIPMENT .....	12
4. OUTPUT POWER.....	14
4.1 OUTPUT POWER MEASUREMENT .....	14
6. BANDEDGE AND EMISSION MASK.....	17
7. OUT OF BAND EMISSIONS .....	18
7.1 MEASUREMENT METHOD .....	19
8. RADIATED MEASUREMENT .....	20
8.1. RADIATED POWER (ERP & EIRP).....	20
8.2 LTE BAND 2.....	21
8.3 LTE BAND 4.....	25
8.4 LTE BAND 5.....	29
8.5 LTE BAND 7.....	31
8.6 LTE BAND 12 .....	33

<b>8.7 LTE BAND 17</b> .....	<b>35</b>
<b>9. SPURIOUS RADIATION EMISSION</b> .....	<b>37</b>
9.1 LTE BAND 2.....	39
9.2 LTE BAND 4.....	41
9.3 LTE BAND 5.....	43
9.4 LTE BAND 7.....	45
9.5 LTE BAND 12 .....	47
9.6 LTE BAND 17 .....	49
<b>10. FREQUENCY STABILITY</b> .....	<b>51</b>
10.1 LTE BAND 2 .....	52
10.2 LTE BAND 4 .....	54
10.3 LTE BAND 5 .....	56
10.4 LTE BAND 7 .....	58
10.5 LTE BAND 12 .....	60
10.6 LTE BAND 17 .....	62
<b>11. PEAK-TO-AVERAGE RATIO</b> .....	<b>64</b>
11.1 Description of the PAR Measurement.....	64
11.2 Measuring Instruments.....	64
11.3 Test Procedures.....	64
11.4 Test Setup.....	64

## 1. GENERAL INFORMATION

### 1.1 PRODUCT DESCRIPTION

A major technical description of EUT is described as following:

Product Designation:	Mobile Phone
Trade Mark	ulefone
Model Name	GQ3103
Family Model	Power Armor 16 Pro, Power Armor 16, Power Armor 16S, Power Armor 16E, Power Armor 16P, Power Armor 16 Plus, Power Armor 16 Lite
Model Difference	All models are the same circuit and RF module, except the model name.
FCC ID:	2AT9T-3103
Frequency Bands:	U.S. Bands: <input checked="" type="checkbox"/> LTE FDD Band 2, 4, 5, 7, 12, 17
Frequency Range:	LTE FDD Band 2 Uplink: 1850MHz-1910MHz, Downlink: 1930MHz-1990MHz; LTE FDD Band 4 Uplink: 1710MHz-1755MHz, Downlink: 2110MHz-2155MHz; LTE FDD Band 5 Uplink: 824MHz-849MHz, Downlink: 869MHz-894MHz; LTE-FDD Band 7 Uplink: 2500MHz-2570MHz, Downlink: 2620MHz-2690MHz; LTE FDD Band 12 Uplink: 699MHz-716MHz, Downlink: 729MHz-746MHz; LTE FDD Band 17 Uplink: 704MHz-716MHz, Downlink: 734MHz-746MHz;
Type of Modulation:	QPSK/16QAM
Power Class	Class 3
Antenna:	PIFA Antenna
Antenna gain:	Band 2: 1.2dBi, Band 4:1.2dBi, Band 5: 1.2dBi, Band 7: 1.2dBi, Band 12:1.2dBi, Band 17: 1.2dBi
Adapter	Model: HJ-FC038K7-US Input: 100-240V~50/60Hz 0.6A Output: 5V---3.0A OR 9V---2.0A OR 12V---1.5A
Battery	DC 3.85V, 9600mAh
Power supply	DC 3.85V from battery or DC 5V from Adapter.
Extreme Vol. Limits:	DC 3.4V to DC 4.2V (Nominal DC 3.85V) (Note 1)
HW Version	F7_01
SW Version	Power Armor 16 Pro_SH1_EEA_V01
** Note1: The High Voltage 4.2V and Low Voltage 3.4V was declared by manufacturer, The EUT couldn't be operate normally with higher or lower voltage.	



## 1.2 RELATED SUBMITTAL(S) / GRANT (S)

This submittal(s) (test report) is intended for **FCC ID: 2AT9T-3103** filing to comply with the FCC Part 22H&24E &27.

## 1.3 TEST METHODOLOGY

The tests documented in this report were performed in accordance with ANSI/TIA-603-E-2016, FCC CFR 47 Part 2, Part 22, Part 24, Part 27, ANSI C63.26:2015.

## 1.4 TEST FACILITY

The test site used to collect the radiated data is located at:

ShenZhen NTEK Testing Technology Co., Ltd.

1/F, Building E, Fenda Science Park, Sanwei Community, Xixiang Street, Bao'an District, Shenzhen 518126 P.R.China.

The test site is constructed and calibrated to meet the FCC requirements in documents ANSI C63.26:2015& ANSI C63.4: 2014.

FCC Registration No.:463705

IC Registration No.:9270A-1,

CNAS Registration No.:L5516

## MEASUREMENT UNCERTAINTY

The reported uncertainty of measurement, where expended uncertainty U is based on a standard uncertainty multiplied by a coverage factor of k=2, providing a level of confidence of approximately 95 %.

No.	Item	Uncertainty
1	Measuring Uncertainty for a Level of Confidence of 95% ( $U = 2Uc(y)$ )	2.5dB
2	Conducted Emission Test	$\pm 1.38$ dB
3	RF power, conducted	$\pm 0.16$ dB
4	Spurious emissions, conducted	$\pm 0.21$ dB
5	All emissions, radiated(<1G)	$\pm 4.68$ dB
6	All emissions, radiated(>1G)	$\pm 4.89$ dB
7	Temperature	$\pm 0.5$ °C
8	Humidity	$\pm 2$ %
9	Frequency error, conducted	$\pm 0.19$ ppm

## 1.5 SPECIAL ACCESSORIES

The battery and the charger, earphone supplied by the applicant were used as accessories and being tested with EUT intended for FCC grant together.

**1.6 WORST-CASE CONFIGURATION AND MODE**

The worst-case scenario for all measurements is based on the investigation results.

The device has LTE Bands of: Band 2, Band 4, Band 5, Band 7, Band 12, Band 17

The RB Size was selected to measure for peak or average ERP and EIRP, which was based on the conducted power verification baseline data.

For the fundamental investigation of radiated emissions, the EUT is investigated for vertical and horizontal antenna orientations and X Y and Z orientations of the EUT alone. After the investigations the worst case was determined to be at X orientation for all LTE bands.

**1.6 SUMMARY OF TEST RESULTS**

FCC Part22, Subpart H/ FCC Part24, Subpart E, FCC Part27, Subpart L, KDB 971168 D01 Power Meas License Digital Systems v03			
FCC Rule	Test Item	Verdict	Remark
2.1046	Conducted Output Power	PASS	
22.913(d) 24.232(d) 27.50(d)(5) KDB 971168 D01 Clause 5.7	Peak-to-Average Ratio	PASS	
2.1049 22.917(b) 24.238(b) KDB 971168 D01 Clause 4.2	Occupied Bandwidth	PASS	
2.1051 22.917(a) 24.238(a) 27.53(m), (g), (h) KDB 971168 D01 Clause 6	Band Edge	PASS	
22.913(a)(2) 27.50(c)(10) KDB 971168 D01 Clause 5.6	Effective Radiated Power	PASS	
24.232(c) 27.50(h)(2), (d)(4) KDB 971168 D01 Clause 5.6	Equivalent Isotropic Radiated Power	PASS	



2.1053 22.917(a) 24.238(a) 27.53(g)(h)(m) KDB 971168 D01 Clause 7	Field Strength of Spurious Radiation	PASS	
2.1055 22.355 24.235 27.54 KDB 971168 D01 Clause 9	Frequency Stability for Temperature & Voltage	PASS	
2.1051 22.917(a) 24.238(a) 27.53(g)(h)(m) KDB 971168 D01 Clause 6	Conducted Emission	PASS	

Remark:

1. "N/A" denotes test is not applicable in this Test Report.
2. All test items were verified and recorded according to the standards and without any deviation during the test.
3. No modifications are made to the EUT during all test items.

## 2. SYSTEM TEST CONFIGURATION

### 2.1 EUT CONFIGURATION

The EUT configuration for testing is installed on RF field strength measurement to meet the Commission's requirement and operating in a manner which intends to maximize its emission characteristics in a continuous normal application.

### 2.2 EUT EXERCISE

The Transmitter was operated in the maximum output power mode through Communication Tester. The TX frequency was fixed which was for the purpose of the measurements.

### 2.3 CONFIGURATION OF EUT SYSTEM

Table 2-1 Equipment Used in EUT System

Item	Equipment	Model No.	ID or Specification	Note
1	Mobile Phone	GQ3103	FCC ID: 2AT9T-3103	EUT

*Note: All the accessories have been used during the test.  
the following "EUT" in setup diagram means EUT system.*

## 2.4 TEST SETUP

For Radiated Test Cases



For Conducted Output Power

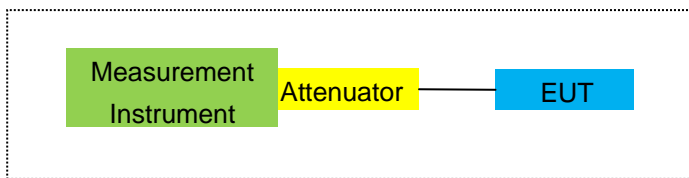

For Peak-to Average Ratio, Occupied Bandwidth, Conducted Band edge and Conducted Spurious Emission

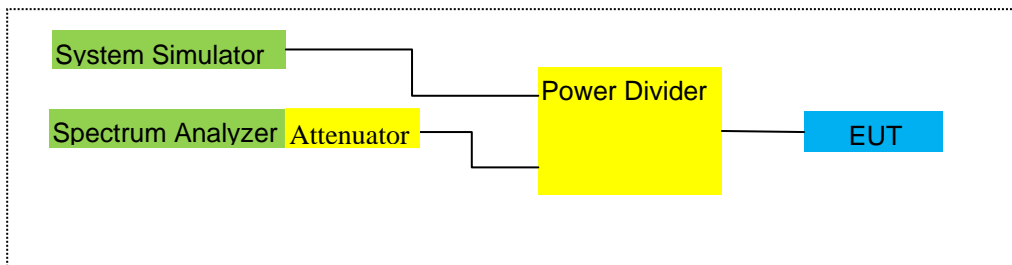

For Frequency Stability

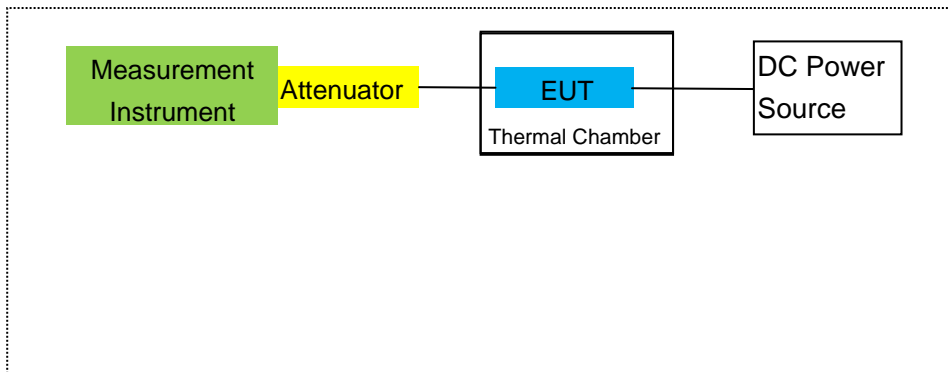

Note: EUT built-in battery-powered, the battery is fully-charged.

### 3. TEST AND MEASUREMENT EQUIPMENT

The following test and measurement equipment was utilized for the tests documented in this report:

Item	Kind of Equipment	Manufacturer	Type No.	Serial No.	Last calibration	Calibrated until	Calibration period
1	MXA Signal Analyzer	Agilent	N9020A	MY49100060	2022.04.06	2023.04.05	1 year
2	Test Receiver	R&S	ESPI	101318	2022.04.06	2023.04.05	1 year
3	Bilog Antenna	TESEQ	CBL6111D	31216	2022.03.30	2023.03.29	1 year
4	50Ω Coaxial Switch	Anritsu	MP59B	6200983705	2020.05.11	2023.05.10	3 year
5	Horn Antenna	EM	EM-AH-10180	2011071402	2022.03.31	2023.03.30	1 year
6	Horn Ant	Schwarzbeck	BBHA 9170	9170-181	2021.11.07	2022.11.06	1 year
7	Amplifier	EM	EM-30180	060538	2022.06.17	2023.06.16	1 year
8	Loop Antenna	ARA	PLA-1030/B	1029	2022.04.06	2023.04.05	1 year
9	Power Meter	R&S	NRVS	100696	2022.06.17	2023.06.16	1 year
10	Power Sensor	R&S	URV5-Z4	0395.1619.05	2022.04.06	2023.04.05	1 year
11	Test Cable	N/A	R-01	N/A	2019.08.06	2022.08.05	3 year
12	Test Cable	N/A	R-02	N/A	2019.08.06	2022.08.05	3 year
13	Test Cable	N/A	R-03	N/A	2022.06.17	2025.06.16	3 year
14	Test Receiver	R&S	ESCI	101160	2022.04.06	2023.04.05	1 year
15	LISN	R&S	ENV216	101313	2022.04.06	2023.04.05	1 year
16	LISN	EMCO	3816/2	00042990	2022.04.06	2023.04.05	1 year
17	50Ω Coaxial Switch	Anritsu	MP59B	6200264417	2022.04.06	2023.04.05	1 year
18	Passive Voltage Probe	R&S	ESH2-Z3	100196	2022.04.06	2023.04.05	1 year
19	Test Cable	N/A	C01	N/A	2020.05.11	2023.05.10	3 year
20	Test Cable	N/A	C02	N/A	2020.05.11	2023.05.10	3 year
21	Test Cable	N/A	C03	N/A	2020.05.11	2023.05.10	3 year
22	Attenuator	MCE	24-10-34	BN9258	2022.06.17	2023.06.16	1 year
23	Spectrum Analyzer	agilent	e4440a	us44300399	2022.04.06	2023.04.05	1 year
24	test receiver	R&S	ESCI	a0304218	2022.04.06	2023.04.05	1 year
25	Communication Tester	R&S	CMU200	A0304247	2022.06.17	2023.06.16	1 year

26	Thermal Chamber	Ten Billion	TTC-B3C	TBN-960502	2022.04.06	2023.04.05	1 year
27	DC Power Source	N/A	PS-6005D	2017040292 3	2020.05.11	2023.05.10	3 year
28	PSG Analog Signal Generator	Agilent	E8257D	MY51110112	2022.06.16	2023.06.15	1 year
29	Communication Tester	R&S	CMW500	148500	2022.06.16	2023.06.15	1 year

Note: Each piece of equipment is scheduled for calibration once a year except the Test Cable& DC Power Source which is scheduled for calibration every 3 years.

## 4. OUTPUT POWER

### 4.1 OUTPUT POWER MEASUREMENT

#### LTE Measurement Procedure:

All LTE bands conducted power peak and average are obtained from the CMW500 telecommunication test set. The following tests were conducted according to the test requirements outlined in section 6.2 of the 3GPP TS36.101 specification.

UE Power Class: 3 (23 +/- 2dBm). The allowed Maximum Power Reduction (MPR) for the maximum output power due to higher order modulation and transmit bandwidth configuration (resource blocks) is specified in Table 6.2.3-1 of the 3GPP TS36.101.

**Table 6.2.3-1: Maximum Power Reduction (MPR) for Power Class 3**

Modulation	Channel bandwidth / Transmission bandwidth (RB)						MPR (dB)
	1.4 MHz	3.0 MHz	5 MHz	10 MHz	15 MHz	20 MHz	
QPSK	> 5	> 4	> 8	> 12	> 16	> 18	≤ 1
16 QAM	≤ 5	≤ 4	≤ 8	≤ 12	≤ 16	≤ 18	≤ 1
16 QAM	> 5	> 4	> 8	> 12	> 16	> 18	≤ 2

The allowed A-MPR values specified below in Table 6.2.4.-1 of 3GPP TS36.101 are in addition to the allowed MPR requirements. All the measurements below were performed with A-MPR disabled, by using Network Signaling Value of "NS\_01".3

**Table 6.2.4-1: Additional Maximum Power Reduction (A-MPR)**

Network Signalling value	Requirements (sub-clause)	E-UTRA Band	Channel bandwidth (MHz)	Resources Blocks ( $N_{RB}$ )	A-MPR (dB)
NS_01	6.6.2.1.1	Table 5.5-1	1.4, 3, 5, 10, 15, 20	Table 5.6-1	NA
NS_03	6.6.2.2.1	2, 4, 10, 23, 25, 35, 36	3	>5	$\leq 1$
			5	>6	$\leq 1$
			10	>6	$\leq 1$
			15	>8	$\leq 1$
			20	>10	$\leq 1$
NS_04	6.6.2.2.2	41	5	>6	$\leq 1$
			10, 15, 20	See Table 6.2.4-4	
NS_05	6.6.3.3.1	1	10,15,20	$\geq 50$	$\leq 1$
NS_06	6.6.2.2.3	12, 13, 14, 17	1.4, 3, 5, 10	Table 5.6-1	n/a
NS_07	6.6.2.2.3	13	10	Table 6.2.4-2	Table 6.2.4-2
	6.6.3.3.2				
NS_08	6.6.3.3.3	19	10, 15	> 44	$\leq 3$
NS_09	6.6.3.3.4	21	10, 15	> 40	$\leq 1$
				> 55	$\leq 2$
NS_10		20	15, 20	Table 6.2.4-3	Table 6.2.4-3
NS_11	6.6.2.2.1	23 <sup>1</sup>	1.4, 3, 5, 10	Table 6.2.4-5	Table 6.2.4-5
..					
NS_32	-	-	-	-	-

Note 1: Applies to the lower block of Band 23, i.e. a carrier placed in the 2000-2010 MHz region.

Test data reference attachment.

## 5. OCCUPIED BANDWIDTH

### RULE PART(S)

FCC: §2.1049

### LIMITS

For reporting purposes only

### TEST PROCEDURE

The transmitter output was connected to a calibrated coaxial cable and coupler, the other end of which was connected to a spectrum analyzer. The occupied bandwidth was measured with the spectrum analyzer at the low, middle and high channel in each band. The -26dB bandwidth was also measured and recorded.

### MODES TESTED

- LTE Band2
- LTE Band 4
- LTE Band 5
- LTE Band 7
- LTE Band 12
- LTE Band 17

### RESULTS

**PASS**

Test data reference attachment.



## 6. BANDEDGE AND EMISSION MASK

### RULE PART(S)

FCC: §2.1051, §22.917(a), §24.238(a), §27.53(c)(g)(h)(m)

FCC: §2.1046, §22.913, §24.232

### LIMITS

The minimum permissible attenuation level of any spurious emission is  $43 + \log_{10}(P[\text{Watts}])$ , where P is the transmitter power in Watts.

The minimum permissible attenuation level for Band 7 is as following.

Per 27.53(g) for operations in the 698-746 MHz band, in the 100 kHz bands immediately outside and adjacent to the frequency block a resolution bandwidth of at least 30 kHz may be employed to demonstrate compliance with the out-of-band emissions limit.

Per 27.53(c.5) for operations in the 776-788 MHz band, in the 100 kHz bands immediately outside and adjacent to the frequency block a resolution bandwidth of at least 30 kHz may be employed to demonstrate compliance with the out-of-band emissions limit.

For all plots showing emissions in the 763 – 775MHz and 793 – 805MHz band, the FCC limit per 27.53(c.4) is  $65 + 10\log_{10}(P) = -35\text{dBm}$  in a 6.25kHz bandwidth.

Per 27.53(m) for operations in the BRS/EBS bands, the attenuation factor shall be not less than  $40 + 10 \log (P)$  dB on all frequencies between the channel edge and 5 megahertz from the channel edge,  $43 + 10 \log (P)$  dB on all frequencies between 5 megahertz and X megahertz from the channel edge, and  $55 + 10 \log (P)$  dB on all frequencies more than X megahertz from the channel edge, where X is the greater of 6 megahertz or the actual emission bandwidth.

### TEST PROCEDURE

The transmitter output was connected to a CMW500Test Set and configured to operate at maximum power. The band edge emissions were measured at the required operating frequencies in each band on the Spectrum Analyzer.

For each band edge measurement:

Set the spectrum analyzer span to include the block edge frequency

Set a marker to point the corresponding band edge frequency in each test case.

Set display line

Set resolution bandwidth to at least 1% of emission bandwidth.

### MODES TESTED

- LTE Band 2/4/5/7/12/17

### RESULTS

Test data reference attachment.

## 7. OUT OF BAND EMISSIONS

### RULE PART(S)

FCC: §2.1051, §22.917(a), §24.238(a), §27.53(c)(g)(h)(m)

### LIMITS

The minimum permissible attenuation level of any spurious emission is  $43 + \log_{10}(P[\text{Watts}])$ , where P is the transmitter power in Watts.

The minimum permissible attenuation level for Band 7 is as following.

Per 27.53(g) for operations in the 698-746 MHz band, in the 100 kHz bands immediately outside and adjacent to the frequency block a resolution bandwidth of at least 30 kHz may be employed to demonstrate compliance with the out-of-band emissions limit.

Per 27.53(c.5) for operations in the 776-788 MHz band, in the 100 kHz bands immediately outside and adjacent to the frequency block a resolution bandwidth of at least 30 kHz may be employed to demonstrate compliance with the out-of-band emissions limit.

For all plots showing emissions in the 763 – 775MHz and 793 – 805MHz band, the FCC limit per 27.53(c.4) is  $65 + 10\log_{10}(P) = -35\text{dBm}$  in a 6.25kHz bandwidth.

Per 27.53(m) for operations in the BRS/EBS bands, the attenuation factor shall be not less than  $40 + 10 \log (P)$  dB on all frequencies between the channel edge and 5 megahertz from the channel edge,  $43 + 10 \log (P)$  dB on all frequencies between 5 megahertz and X megahertz from the channel edge, and  $55 + 10 \log (P)$  dB on all frequencies more than X megahertz from the channel edge, where X is the greater of 6 megahertz or the actual emission bandwidth.

### TEST PROCEDURE

The RF output of the transmitter was connected to a spectrum analyzer through a calibrated coaxial cable. Sufficient scans were taken to show the out-of-band Emissions, if any, up to 10th harmonic. Multiple sweeps were recorded in maximum hold mode using a peak detector to ensure that the worst-case emissions were caught.

For each out of band emissions measurement:

- Set display line
- Set RBW & VBW to 100 kHz for the measurement below 1 GHz, and 1 MHz for the measurement above 1 GHz.

### MODES TESTED

- LTE Band2
- LTE Band 4
- LTE Band 5
- LTE Band 7
- LTE Band 12
- LTE Band 17

## 7.1 MEASUREMENT METHOD

The test set up and general procedure is similar to conducted peak output power test. Only different for setting the measurement configuration of the measuring instrument of Spectrum Analyzer.

### **Test data reference attachment.**

Note: the amplitude of spurious emission that is attenuated by more than 20dB below the permissible limit has no need to be reported (LTE Band 2/4/7: above 10GHz).

## 8. RADIATED MEASUREMENT

### 8.1. RADIATED POWER (ERP & EIRP)

#### RULE PART(S)

FCC: §2.1046, §22.913(a)(2), §24.232(c) and §27.50 (h)(2), (b)(10), (c)(10), (d)(4)

#### LIMITS:

22.913(a) (2)- The ERP of mobile transmitters and auxiliary test transmitters must not exceed 7 Watts.  
24.232 (c) Mobile and portable stations are limited to 2 watts EIRP.  
27.50 (c) (10) the following power and antenna height requirements apply to stations transmitting in the 698–746 MHz band, the portable stations (hand-held devices) are limited to 3 watts ERP.  
27.50 (b)(10) Portable stations (hand-held devices) transmitting in the 746–757 MHz, 758–763 MHz, 776–793 MHz, and 805–806 MHz bands are limited to 3 watts ERP.  
27.50 (d)(4) The following power and antenna height requirements apply to stations transmitting in the 1710–1755 MHz and 2110–2155 MHz bands: Fixed, mobile, and portable (hand-held) stations operating in the 1710–1755 MHz band are limited to 1 watt EIRP.  
27.50 (h)(2) Mobile and other user stations in the 2500–2570 MHz and 2620–2690 MHz bands. Mobile stations are limited to 2.0 watts EIRP. All user stations are limited to 2.0 watts transmitter output power.

#### TEST PROCEDURE

ANSI/TIA-603-E Clause 2.2.17

KDB 971168 v02r01 RF power output using broadband peak and average power meter method.

KDB 971168 D01 Power Meas License Digital Systems v02r01, “Measurement Guidance for Certification of Licensed Digital Transmitters”

#### MODES TESTED

- LTE Band2
- LTE Band 4
- LTE Band 5
- LTE Band 7
- LTE Band 12
- LTE Band 17

#### RESULTS

Pass

## 8.2 LTE BAND 2

Radiated Power (EIRP) for Band 2									
Mode	RB/RB SIZE	Frequency	Result					Polarization Of Max. ERP	Conclusion
			SG Level (dBm)	Cable Loss (dBm)	Antenna Factor (dB)	Max. EIRP Average (dBm)	Max. EIRP		
							Average (mW)		
1.4MHz Band QPSK	1/#Mid	1850.7	-3.08	3.76	28.24	21.40	138.038	Horizontal	Pass
		1880	-2.89	3.91	28.22	21.42	138.676	Horizontal	Pass
		1909.3	-2.80	3.93	28.20	21.47	140.281	Horizontal	Pass
3.0MHz Band QPSK	1/#Mid	1851.5	-3.14	3.77	28.23	21.32	135.519	Horizontal	Pass
		1880	-2.99	3.91	28.24	21.34	136.144	Horizontal	Pass
		1908.5	-2.86	3.94	28.25	21.45	139.637	Horizontal	Pass
5.0MHz Band QPSK	1/#Mid	1852.5	-3.03	3.77	28.31	21.51	141.579	Horizontal	Pass
		1880	-2.65	3.91	28.22	21.66	146.555	Horizontal	Pass
		1907.5	-2.58	3.94	28.20	21.68	147.231	Horizontal	Pass
10.0MHz Band QPSK	1/#Mid	1855	-2.89	3.79	28.33	21.65	146.218	Horizontal	Pass
		1880	-2.59	3.95	28.22	21.68	147.231	Horizontal	Pass
		1905	-2.48	3.97	28.19	21.74	149.279	Horizontal	Pass
15.0MHz Band QPSK	1/#Mid	1857.5	-2.85	3.79	28.34	21.70	147.911	Horizontal	Pass
		1880	-2.64	3.95	28.22	21.63	145.546	Horizontal	Pass
		1902.5	-2.50	3.97	28.18	21.71	148.252	Horizontal	Pass
20.0MHz Band QPSK	1/#Mid	1860	-2.84	3.81	28.35	21.70	147.911	Horizontal	Pass
		1880	-2.51	3.96	28.22	<b>21.75</b>	149.624	Horizontal	Pass
		1900	-2.45	4.00	28.16	21.71	148.252	Horizontal	Pass
1.4MHz Band QPSK	1/#Mid	1850.7	-3.90	3.76	28.24	20.58	114.288	Vertical	Pass
		1880	-3.66	3.91	28.22	20.65	116.145	Vertical	Pass
		1909.3	-3.93	3.93	28.20	20.34	108.143	Vertical	Pass
3.0MHz Band QPSK	1/#Mid	1851.5	-3.77	3.77	28.23	20.69	117.220	Vertical	Pass
		1880	-3.38	3.91	28.24	20.95	124.451	Vertical	Pass
		1908.5	-3.80	3.94	28.25	20.51	112.460	Vertical	Pass
5.0MHz Band QPSK	1/#Mid	1852.5	-3.84	3.77	28.31	20.70	117.490	Vertical	Pass
		1880	-4.13	3.91	28.22	20.18	104.232	Vertical	Pass
		1907.5	-3.34	3.94	28.20	20.92	123.595	Vertical	Pass
10.0MHz Band QPSK	1/#Mid	1855	-4.39	3.79	28.33	20.15	103.514	Vertical	Pass
		1880	-3.39	3.95	28.22	20.88	122.462	Vertical	Pass
		1905	-3.70	3.97	28.19	20.52	112.720	Vertical	Pass

15.0MHz		1857.5	-4.10	3.79	28.34	20.45	110.917	Vertical	Pass
Band	1/#Mid	1880	-3.65	3.95	28.22	20.62	115.345	Vertical	Pass
QPSK		1902.5	-3.86	3.97	28.18	20.35	108.393	Vertical	Pass
20.0MHz		1860	-4.17	3.81	28.35	20.37	108.893	Vertical	Pass
Band	1/#Mid	1880	-3.76	3.96	28.22	20.50	112.202	Vertical	Pass
QPSK		1900	-3.44	4.00	28.16	20.72	118.032	Vertical	Pass

Note:

SG Level= Signal generator output

Max. EIRP Average (dBm)= Antenna Factor (dB)+ SG Level (dBm)- Cable Loss(dBm)

Radiated Power (EIRP) for Band 2									
Mode	RB/RB SIZE	Frequency	Result						Conclusion
			SG Level (dBm)	Cable Loss (dBm)	Antenna Factor (dB)	Max. EIRP Average (dBm)	Max. EIRP Average (mW)	Polarization Of Max. ERP	
1.4MHz Band 16 QAM	1/#Mid	1850.7	-4.20	3.76	28.24	20.28	106.660	Horizontal	Pass
		1880	-3.67	3.91	28.22	20.64	115.878	Horizontal	Pass
		1909.3	-3.60	3.93	28.20	20.67	116.681	Horizontal	Pass
3.0MHz Band 16 QAM	1/#Mid	1851.5	-3.70	3.77	28.23	20.76	119.124	Horizontal	Pass
		1880	-3.78	3.91	28.24	20.55	113.501	Horizontal	Pass
		1908.5	-3.99	3.94	28.25	20.32	107.647	Horizontal	Pass
5.0MHz Band 16 QAM	1/#Mid	1852.5	-3.64	3.77	28.31	20.90	123.027	Horizontal	Pass
		1880	-3.55	3.91	28.22	20.76	119.124	Horizontal	Pass
		1907.5	-3.23	3.94	28.20	21.03	126.765	Horizontal	Pass
10.0MHz Band 16 QAM	1/#Mid	1855	-3.69	3.79	28.33	20.85	121.619	Horizontal	Pass
		1880	-3.68	3.95	28.22	20.59	114.551	Horizontal	Pass
		1905	-3.15	3.97	28.19	21.07	127.938	Horizontal	Pass
15.0MHz Band 16 QAM	1/#Mid	1857.5	-3.67	3.79	28.34	20.88	122.462	Horizontal	Pass
		1880	-3.46	3.95	28.22	20.81	120.504	Horizontal	Pass
		1902.5	-3.42	3.97	28.18	20.79	119.950	Horizontal	Pass
20.0MHz Band 16 QAM	1/#Mid	1860	-3.56	3.81	28.35	20.98	125.314	Horizontal	Pass
		1880	-3.26	3.96	28.22	21.00	125.893	Horizontal	Pass
		1900	-3.08	4.00	28.16	<b>21.08</b>	128.233	Horizontal	Pass
1.4MHz Band 16 QAM	1/#Mid	1850.7	-4.93	3.76	28.24	19.55	90.157	Vertical	Pass
		1880	-4.96	3.91	28.22	19.35	86.099	Vertical	Pass
		1909.3	-4.63	3.93	28.20	19.64	92.045	Vertical	Pass
3.0MHz Band 16 QAM	1/#Mid	1851.5	-5.27	3.77	28.23	19.19	82.985	Vertical	Pass
		1880	-4.83	3.91	28.24	19.50	89.125	Vertical	Pass
		1908.5	-4.80	3.94	28.25	19.51	89.331	Vertical	Pass
5.0MHz Band 16 QAM	1/#Mid	1852.5	-4.59	3.77	28.31	19.95	98.855	Vertical	Pass
		1880	-5.16	3.91	28.22	19.15	82.224	Vertical	Pass
		1907.5	-4.80	3.94	28.20	19.46	88.308	Vertical	Pass
10.0MHz Band 16 QAM	1/#Mid	1855	-4.49	3.79	28.33	20.05	101.158	Vertical	Pass
		1880	-5.01	3.95	28.22	19.26	84.333	Vertical	Pass
		1905	-5.01	3.97	28.19	19.21	83.368	Vertical	Pass
15.0MHz Band 16	1/#Mid	1857.5	-5.29	3.79	28.34	19.26	84.333	Vertical	Pass
		1880	-4.43	3.95	28.22	19.84	96.383	Vertical	Pass

QAM		1902.5	-4.33	3.97	28.18	19.88	97.275	Vertical	Pass
20.0MHz	1/#Mid	1860	-4.49	3.81	28.35	20.05	101.158	Vertical	Pass
Band 16		1880	-4.35	3.96	28.22	19.91	97.949	Vertical	Pass
QAM		1900	-4.46	4.00	28.16	19.70	93.325	Vertical	Pass

Note:

SG Level= Signal generator output

Max. EIRP Average (dBm)= Antenna Factor (dB)+ SG Level (dBm)- Cable Loss(dBm)



### 8.3 LTE BAND 4

Radiated Power (EIRP) for Band 4									
Mode	RB/RB SIZE	Frequency	Result					Polarization Of Max. ERP	Conclusion
			SG Level	Cable Loss	Antenna Factor	Max. EIRP	Max. EIRP		
			(dBm)	(dBm)	(dB)	Average	Average		
						(dBm)	(mW)		
1.4MHz Band QPSK	1/#Mid	1710.7	-2.99	3.12	27.58	21.47	140.281	Horizontal	Pass
		1732.5	-2.98	3.27	27.61	21.36	136.773	Horizontal	Pass
		1754.3	-2.96	3.29	27.63	21.38	137.404	Horizontal	Pass
3.0MHz Band QPSK	1/#Mid	1711.5	-3.16	3.13	27.61	21.32	135.519	Horizontal	Pass
		1732.5	-3.08	3.27	27.61	21.26	133.660	Horizontal	Pass
		1753.5	-3.00	3.30	27.62	21.32	135.519	Horizontal	Pass
5.0MHz Band QPSK	1/#Mid	1712.5	-2.93	3.13	27.63	21.57	143.549	Horizontal	Pass
		1732.5	-2.83	3.27	27.61	21.51	141.579	Horizontal	Pass
		1752.5	-2.71	3.30	27.60	21.59	144.212	Horizontal	Pass
10.0MHz Band QPSK	1/#Mid	1715	-2.87	3.15	27.64	21.62	145.211	Horizontal	Pass
		1732.5	-2.64	3.31	27.61	21.66	146.555	Horizontal	Pass
		1750	-2.66	3.33	27.59	21.60	144.544	Horizontal	Pass
15.0MHz Band QPSK	1/#Mid	1717.5	-2.88	3.15	27.65	21.62	145.211	Horizontal	Pass
		1732.5	-2.72	3.31	27.61	21.58	143.880	Horizontal	Pass
		1747.5	-2.66	3.33	27.57	21.58	143.880	Horizontal	Pass
20.0MHz Band QPSK	1/#Mid	1720	-2.82	3.17	27.66	<b>21.67</b>	146.893	Horizontal	Pass
		1732.5	-2.65	3.32	27.61	21.64	145.881	Horizontal	Pass
		1745	-2.59	3.36	27.56	21.61	144.877	Horizontal	Pass
1.4MHz Band QPSK	1/#Mid	1710.7	-3.48	3.12	27.58	20.98	125.314	Vertical	Pass
		1732.5	-3.32	3.27	27.61	21.02	126.474	Vertical	Pass
		1754.3	-3.98	3.29	27.63	20.36	108.643	Vertical	Pass
3.0MHz Band QPSK	1/#Mid	1711.5	-4.30	3.13	27.61	20.18	104.232	Vertical	Pass
		1732.5	-3.24	3.27	27.61	21.10	128.825	Vertical	Pass
		1753.5	-3.50	3.30	27.62	20.82	120.781	Vertical	Pass
5.0MHz Band QPSK	1/#Mid	1712.5	-3.59	3.13	27.63	20.91	123.310	Vertical	Pass
		1732.5	-3.43	3.27	27.61	20.91	123.310	Vertical	Pass
		1752.5	-4.11	3.30	27.60	20.19	104.472	Vertical	Pass
10.0MHz Band QPSK	1/#Mid	1715	-4.29	3.15	27.64	20.20	104.713	Vertical	Pass
		1732.5	-3.92	3.31	27.61	20.38	109.144	Vertical	Pass
		1750	-3.72	3.33	27.59	20.54	113.240	Vertical	Pass

15.0MHz		1717.5	-3.58	3.15	27.65	20.92	123.595	Vertical	Pass
Band	1/#Mid	1732.5	-4.06	3.31	27.61	20.24	105.682	Vertical	Pass
QPSK		1747.5	-3.32	3.33	27.57	20.92	123.595	Vertical	Pass
20.0MHz		1720	-3.38	3.17	27.66	21.11	129.122	Vertical	Pass
Band	1/#Mid	1732.5	-3.36	3.32	27.61	20.93	123.880	Vertical	Pass
QPSK		1745	-3.47	3.36	27.56	20.73	118.304	Vertical	Pass

Note:

SG Level= Signal generator output

Max. EIRP Average (dBm)= Antenna Factor (dB)+ SG Level (dBm)- Cable Loss(dBm)

Radiated Power (EIRP) for Band 4									
Mode	RB/RB SIZE	Frequency	Result						Conclusion
			SG Level (dBm)	Cable Loss (dBm)	Antenna Factor (dB)	Max. EIRP	Max. EIRP	Polarization Of Max. ERP	
						Average	Average		
						(dBm)	(mW)		
1.4MHz Band 16 QAM	1/#Mid	1710.7	-3.80	3.12	27.58	20.66	116.413	Horizontal	Pass
		1732.5	-3.65	3.27	27.61	20.69	117.220	Horizontal	Pass
		1754.3	-3.65	3.29	27.63	20.69	117.220	Horizontal	Pass
3.0MHz Band 16 QAM	1/#Mid	1711.5	-3.74	3.13	27.61	20.74	118.577	Horizontal	Pass
		1732.5	-3.87	3.27	27.61	20.47	111.429	Horizontal	Pass
		1753.5	-4.09	3.30	27.62	20.23	105.439	Horizontal	Pass
5.0MHz Band 16 QAM	1/#Mid	1712.5	-3.57	3.13	27.63	20.93	123.880	Horizontal	Pass
		1732.5	-3.53	3.27	27.61	20.81	120.504	Horizontal	Pass
		1752.5	-3.22	3.30	27.60	21.08	128.233	Horizontal	Pass
10.0MHz Band 16 QAM	1/#Mid	1715	-3.64	3.15	27.64	20.85	121.619	Horizontal	Pass
		1732.5	-3.83	3.31	27.61	20.47	111.429	Horizontal	Pass
		1750	-3.21	3.33	27.59	21.05	127.350	Horizontal	Pass
15.0MHz Band 16 QAM	1/#Mid	1717.5	-3.44	3.15	27.65	21.06	127.644	Horizontal	Pass
		1732.5	-3.50	3.31	27.61	20.80	120.226	Horizontal	Pass
		1747.5	-3.52	3.33	27.57	20.72	118.032	Horizontal	Pass
20.0MHz Band 16 QAM	1/#Mid	1720	-3.39	3.17	27.66	<b>21.10</b>	128.825	Horizontal	Pass
		1732.5	-3.40	3.32	27.61	20.89	122.744	Horizontal	Pass
		1745	-3.21	3.36	27.56	20.99	125.603	Horizontal	Pass
1.4MHz Band 16 QAM	1/#Mid	1710.7	-4.47	3.12	27.58	19.99	99.770	Vertical	Pass
		1732.5	-4.29	3.27	27.61	20.05	101.158	Vertical	Pass
		1754.3	-4.69	3.29	27.63	19.65	92.257	Vertical	Pass
3.0MHz Band 16 QAM	1/#Mid	1711.5	-4.37	3.13	27.61	20.11	102.565	Vertical	Pass
		1732.5	-4.48	3.27	27.61	19.86	96.828	Vertical	Pass
		1753.5	-5.13	3.30	27.62	19.19	82.985	Vertical	Pass
5.0MHz Band 16 QAM	1/#Mid	1712.5	-5.12	3.13	27.63	19.38	86.696	Vertical	Pass
		1732.5	-4.88	3.27	27.61	19.46	88.308	Vertical	Pass
		1752.5	-4.53	3.30	27.60	19.77	94.842	Vertical	Pass
10.0MHz Band 16 QAM	1/#Mid	1715	-4.48	3.15	27.64	20.01	100.231	Vertical	Pass
		1732.5	-5.05	3.31	27.61	19.25	84.140	Vertical	Pass
		1750	-4.16	3.33	27.59	20.10	102.329	Vertical	Pass
15.0MHz Band 16	1/#Mid	1717.5	-4.89	3.15	27.65	19.61	91.411	Vertical	Pass
		1732.5	-4.67	3.31	27.61	19.63	91.833	Vertical	Pass

QAM		1747.5	-4.53	3.33	27.57	19.71	93.541	Vertical	Pass
20.0MHz	1/#Mid	1720	-5.12	3.17	27.66	19.37	86.497	Vertical	Pass
Band 16		1732.5	-4.99	3.32	27.61	19.30	85.114	Vertical	Pass
QAM		1745	-4.86	3.36	27.56	19.34	85.901	Vertical	Pass

Note:

SG Level= Signal generator output

Max. EIRP Average (dBm)= Antenna Factor (dB)+ SG Level (dBm)- Cable Loss(dBm)

### 8.4 LTE BAND 5

Radiated Power (ERP) for Band 5											
Mode	RB/RB SIZE	Frequency	Result							Polarization Of Max. ERP	Conclusion
			SG Level	Cable Loss (dBm)	Antenna Factor (dB)	Correction (dB)	Max. EIRP	Max. EIRP			
			(dBm)				Average	Average			
							(dBm)	(mW)			
1.4MHz Band QPSK	3/#Mid	824.7	6.60	2.01	19.68	2.15	22.12	162.930	Horizontal	Pass	
		836.5	6.48	2.01	19.77	2.15	22.09	161.808	Horizontal	Pass	
		848.3	6.28	2.02	19.82	2.15	21.93	155.955	Horizontal	Pass	
3.0MHz Band QPSK	1/#Mid	825.5	6.37	2.01	19.70	2.15	21.91	155.239	Horizontal	Pass	
		836.5	6.27	2.01	19.77	2.15	21.88	154.170	Horizontal	Pass	
		847.5	6.14	2.02	19.81	2.15	21.78	150.661	Horizontal	Pass	
5.0MHz Band QPSK	1/#Mid	826.5	6.65	2.01	19.71	2.15	22.20	165.959	Horizontal	Pass	
		836.5	6.53	2.01	19.77	2.15	22.14	163.682	Horizontal	Pass	
		846.5	6.37	2.02	19.79	2.15	21.99	158.125	Horizontal	Pass	
10.0MHz Band QPSK	1/#Mid	829	6.67	2.01	19.73	2.15	<b>22.24</b>	167.494	Horizontal	Pass	
		836.5	6.62	2.01	19.77	2.15	22.23	167.109	Horizontal	Pass	
		844	6.52	2.02	19.78	2.15	22.13	163.305	Horizontal	Pass	
1.4MHz Band QPSK	1/#Mid	824.7	5.00	2.01	19.68	2.15	20.52	112.720	Vertical	Pass	
		836.5	5.21	2.01	19.77	2.15	20.82	120.781	Vertical	Pass	
		848.3	5.68	2.02	19.82	2.15	21.33	135.831	Vertical	Pass	
3.0MHz Band QPSK	1/#Mid	825.5	4.88	2.01	19.70	2.15	20.42	110.154	Vertical	Pass	
		836.5	5.47	2.01	19.77	2.15	21.08	128.233	Vertical	Pass	
		847.5	5.42	2.02	19.81	2.15	21.06	127.644	Vertical	Pass	
5.0MHz Band QPSK	1/#Mid	826.5	5.58	2.01	19.71	2.15	21.13	129.718	Vertical	Pass	
		836.5	5.11	2.01	19.77	2.15	20.72	118.032	Vertical	Pass	
		846.5	4.94	2.02	19.79	2.15	20.56	113.763	Vertical	Pass	
10.0MHz Band QPSK	1/#Mid	829	5.28	2.01	19.73	2.15	20.85	121.619	Vertical	Pass	
		836.5	5.58	2.01	19.77	2.15	21.19	131.522	Vertical	Pass	
		844	5.33	2.02	19.78	2.15	20.94	124.165	Vertical	Pass	

Radiated Power (ERP) for Band 5										
Mode	RB/RB SIZE	Frequency	Result							Conclusion
			SG Level	Cable Loss (dBm)	Antenna Factor (dB)	Correction (dB)	Max. EIRP	Max. EIRP	Polarization Of Max. ERP	
			(dBm)				Average	Average		
							(dBm)	(mW)		
1.4MHz Band 16 QAM	3/#Mid	824.7	5.75	2.01	19.68	2.15	21.27	133.968	Horizontal	Pass
		836.5	5.68	2.01	19.77	2.15	21.29	134.586	Horizontal	Pass
		848.3	5.52	2.02	19.82	2.15	21.17	130.918	Horizontal	Pass
3.0MHz Band 16 QAM	1/#Mid	825.5	5.83	2.01	19.70	2.15	21.37	137.088	Horizontal	Pass
		836.5	5.54	2.01	19.77	2.15	21.15	130.317	Horizontal	Pass
		847.5	5.02	2.02	19.81	2.15	20.66	116.413	Horizontal	Pass
5.0MHz Band 16 QAM	1/#Mid	826.5	6.15	2.01	19.71	2.15	21.70	147.911	Horizontal	Pass
		836.5	5.92	2.01	19.77	2.15	21.53	142.233	Horizontal	Pass
		846.5	5.67	2.02	19.79	2.15	21.29	134.586	Horizontal	Pass
10.0MHz Band 16 QAM	1/#Mid	829	6.15	2.01	19.73	2.15	<b>21.72</b>	148.594	Horizontal	Pass
		836.5	5.87	2.01	19.77	2.15	21.48	140.605	Horizontal	Pass
		844	5.41	2.02	19.78	2.15	21.02	126.474	Horizontal	Pass
1.4MHz Band 16 QAM	1/#Mid	824.7	4.50	2.01	19.68	2.15	20.02	100.462	Vertical	Pass
		836.5	5.27	2.01	19.77	2.15	20.88	122.462	Vertical	Pass
		848.3	5.32	2.02	19.82	2.15	20.97	125.026	Vertical	Pass
3.0MHz Band 16 QAM	1/#Mid	825.5	3.93	2.01	19.70	2.15	19.47	88.512	Vertical	Pass
		836.5	5.21	2.01	19.77	2.15	20.82	120.781	Vertical	Pass
		847.5	4.20	2.02	19.81	2.15	19.84	96.383	Vertical	Pass
5.0MHz Band 16 QAM	1/#Mid	826.5	5.02	2.01	19.71	2.15	20.57	114.025	Vertical	Pass
		836.5	4.65	2.01	19.77	2.15	20.26	106.170	Vertical	Pass
		846.5	5.03	2.02	19.79	2.15	20.65	116.145	Vertical	Pass
10.0MHz Band 16 QAM	1/#Mid	829	4.78	2.01	19.73	2.15	20.35	108.393	Vertical	Pass
		836.5	5.79	2.01	19.77	2.15	21.40	138.038	Vertical	Pass
		844	4.30	2.02	19.78	2.15	19.91	97.949	Vertical	Pass

Note:

ERP=EIRP-2.15

SG Level= Signal generator output

Max. EIRP Average (dBm)= Antenna Factor (dB)+ SG Level (dBm)- Cable Loss(dBm)

### 8.5 LTE BAND 7

Radiated Power (EIRP) for Band 7									
Mode	RB/RB SIZE	Frequency	Result					Polarization Of Max. ERP	Conclusion
			SG Level	Cable Loss	Antenna Factor	Max. EIRP	Max. EIRP		
			(dBm)	(dBm)	(dB)	Average	Average		
						(dBm)	(mW)		
5.0MHz Band QPSK	1/#Mid	2502.5	-1.27	4.54	27.75	21.94	156.315	Horizontal	Pass
		2535	-1.10	4.69	27.72	21.93	155.955	Horizontal	Pass
		2567.5	-1.03	4.71	27.71	21.97	157.398	Horizontal	Pass
10.0MHz Band QPSK	1/#Mid	2505	-1.20	4.55	27.76	22.01	158.855	Horizontal	Pass
		2535	-1.01	4.69	27.72	22.02	159.221	Horizontal	Pass
		2565	-0.93	4.72	27.70	22.05	160.325	Horizontal	Pass
15.0MHz Band QPSK	1/#Mid	2507.5	-1.21	4.55	27.77	22.01	158.855	Horizontal	Pass
		2535	-1.07	4.69	27.72	21.96	157.036	Horizontal	Pass
		2562.5	-0.97	4.72	27.69	22.00	158.489	Horizontal	Pass
20.0MHz Band QPSK	1/#Mid	2510	-1.15	4.57	27.78	<b>22.06</b>	160.694	Horizontal	Pass
		2535	-0.97	4.73	27.72	22.02	159.221	Horizontal	Pass
		2560	-0.93	4.75	27.68	22.00	158.489	Horizontal	Pass
5.0MHz Band QPSK	1/#Mid	2502.5	-2.98	4.54	27.75	20.23	105.439	Vertical	Pass
		2535	-2.54	4.69	27.72	20.49	111.944	Vertical	Pass
		2567.5	-2.30	4.71	27.71	20.70	117.490	Vertical	Pass
10.0MHz Band QPSK	1/#Mid	2505	-2.63	4.55	27.76	20.58	114.288	Vertical	Pass
		2535	-2.23	4.69	27.72	20.80	120.226	Vertical	Pass
		2565	-2.21	4.72	27.70	20.77	119.399	Vertical	Pass
15.0MHz Band QPSK	1/#Mid	2507.5	-2.68	4.55	27.77	20.54	113.240	Vertical	Pass
		2535	-2.19	4.69	27.72	20.84	121.339	Vertical	Pass
		2562.5	-2.25	4.72	27.69	20.72	118.032	Vertical	Pass
20.0MHz Band QPSK	1/#Mid	2510	-3.04	4.57	27.78	20.17	103.992	Vertical	Pass
		2535	-1.91	4.73	27.72	21.08	128.233	Vertical	Pass
		2560	-1.93	4.75	27.68	21.00	125.893	Vertical	Pass

Radiated Power (EIRP) for Band 7									
Mode	RB/RB SIZE	Frequency	Result						Conclusion
			SG Level	Cable Loss	Antenna Factor	Max. EIRP	Max. EIRP	Polarization	
			(dBm)			Average	Average		
				(dB)	(dBm)	(mW)			
5.0MHz Band 16 QAM	1/#Mid	2502.5	-1.96	4.54	27.75	21.25	133.352	Horizontal	Pass
		2535	-1.65	4.69	27.72	21.38	137.404	Horizontal	Pass
		2567.5	-1.73	4.71	27.71	21.27	133.968	Horizontal	Pass
10.0MHz Band 16 QAM	1/#Mid	2505	-1.85	4.55	27.76	21.36	136.773	Horizontal	Pass
		2535	-1.86	4.69	27.72	21.17	130.918	Horizontal	Pass
		2565	-2.13	4.72	27.70	20.85	121.619	Horizontal	Pass
15.0MHz Band 16 QAM	1/#Mid	2507.5	-2.03	4.55	27.77	21.19	131.522	Horizontal	Pass
		2535	-2.00	4.69	27.72	21.03	126.765	Horizontal	Pass
		2562.5	-1.61	4.72	27.69	21.36	136.773	Horizontal	Pass
20.0MHz Band 16 QAM	1/#Mid	2510	-1.91	4.57	27.78	21.30	134.896	Horizontal	Pass
		2535	-1.58	4.73	27.72	21.41	138.357	Horizontal	Pass
		2560	-1.68	4.75	27.68	21.25	133.352	Horizontal	Pass
5.0MHz Band 16 QAM	1/#Mid	2502.5	-3.30	4.54	27.75	19.91	97.949	Vertical	Pass
		2535	-2.88	4.69	27.72	20.15	103.514	Vertical	Pass
		2567.5	-2.76	4.71	27.71	20.24	105.682	Vertical	Pass
10.0MHz Band 16 QAM	1/#Mid	2505	-2.75	4.55	27.76	20.46	111.173	Vertical	Pass
		2535	-1.99	4.69	27.72	21.04	127.057	Vertical	Pass
		2565	-2.58	4.72	27.70	20.40	109.648	Vertical	Pass
15.0MHz Band 16 QAM	1/#Mid	2507.5	-3.80	4.55	27.77	19.42	87.498	Vertical	Pass
		2535	-3.85	4.69	27.72	19.18	82.794	Vertical	Pass
		2562.5	-3.62	4.72	27.69	19.35	86.099	Vertical	Pass
20.0MHz Band 16 QAM	1/#Mid	2510	-3.75	4.57	27.78	19.46	88.308	Vertical	Pass
		2535	-3.31	4.73	27.72	19.68	92.897	Vertical	Pass
		2560	-2.46	4.75	27.68	20.47	111.429	Vertical	Pass

Note:

SG Level= Signal generator output

Max. EIRP Average (dBm)= Antenna Factor (dB)+ SG Level (dBm)- Cable Loss(dBm)



### 8.6 LTE BAND 12

Radiated Power (ERP) for Band 12											
Mode	RB/RB SIZE	Frequency	Result							Polarization Of Max. ERP	Conclusion
			SG Level	Cable Loss (dBm)	Antenna Factor (dB)	Correction (dB)	Max. EIRP	Max. EIRP			
			(dBm)				Average	Average			
							(dBm)	(mW)			
1.4MHz Band QPSK	1#Mid	699.7	6.97	1.91	19.21	2.15	22.12	162.930	Vertical	Pass	
		707.5	6.89	1.91	19.26	2.15	22.09	161.808	Vertical	Pass	
		715.3	6.67	1.93	19.34	2.15	21.93	155.955	Vertical	Pass	
3.0MHz Band QPSK	1#Mid	700.5	6.76	1.91	19.21	2.15	21.91	155.239	Vertical	Pass	
		707.5	6.68	1.91	19.26	2.15	21.88	154.170	Vertical	Pass	
		714.5	6.52	1.93	19.34	2.15	21.78	150.661	Vertical	Pass	
5.0MHz Band QPSK	1#Mid	701.5	7.03	1.91	19.23	2.15	22.20	165.959	Vertical	Pass	
		707.5	6.94	1.91	19.26	2.15	22.14	163.682	Vertical	Pass	
		713.5	6.73	1.92	19.33	2.15	21.99	158.125	Vertical	Pass	
10.0MHz Band QPSK	1#Mid	704	7.05	1.91	19.25	2.15	<b>22.24</b>	167.494	Vertical	Pass	
		707.5	7.03	1.91	19.26	2.15	22.23	167.109	Vertical	Pass	
		711	6.88	1.92	19.32	2.15	22.13	163.305	Vertical	Pass	
1.4MHz Band QPSK	1#Mid	699.7	6.05	1.91	19.21	2.15	21.20	131.826	Horizontal	Pass	
		707.5	6.19	1.91	19.26	2.15	21.39	137.721	Horizontal	Pass	
		715.3	5.49	1.93	19.34	2.15	20.75	118.850	Horizontal	Pass	
3.0MHz Band QPSK	1#Mid	700.5	5.62	1.91	19.21	2.15	20.77	119.399	Horizontal	Pass	
		707.5	5.81	1.91	19.26	2.15	21.01	126.183	Horizontal	Pass	
		714.5	5.28	1.93	19.34	2.15	20.54	113.240	Horizontal	Pass	
5.0MHz Band QPSK	1#Mid	701.5	6.05	1.91	19.23	2.15	21.22	132.434	Horizontal	Pass	
		707.5	6.03	1.91	19.26	2.15	21.23	132.739	Horizontal	Pass	
		713.5	5.55	1.92	19.33	2.15	20.81	120.504	Horizontal	Pass	
10.0MHz Band QPSK	1#Mid	704	5.49	1.91	19.25	2.15	20.68	116.950	Horizontal	Pass	
		707.5	5.65	1.91	19.26	2.15	20.85	121.619	Horizontal	Pass	
		711	6.09	1.92	19.32	2.15	21.34	136.144	Horizontal	Pass	

Radiated Power (ERP) for Band 12										
Mode	RB/RB SIZE	Frequency	Result							Conclusion
			SG Level	Cable Loss (dBm)	Antenna Factor (dB)	Correction (dB)	Max. EIRP	Max. EIRP	Polarization Of Max. ERP	
			(dBm)				Average	Average		
							(dBm)	(mW)		
1.4MHz Band 16 QAM	1/#Mid	699.7	6.93	1.91	19.21	2.15	22.08	161.436	Vertical	Pass
		707.5	6.85	1.91	19.26	2.15	22.05	160.325	Vertical	Pass
		715.3	6.63	1.93	19.34	2.15	21.89	154.525	Vertical	Pass
3.0MHz Band 16 QAM	1/#Mid	700.5	6.72	1.91	19.21	2.15	21.87	153.815	Vertical	Pass
		707.5	6.64	1.91	19.26	2.15	21.84	152.757	Vertical	Pass
		714.5	6.48	1.93	19.34	2.15	21.74	149.279	Vertical	Pass
5.0MHz Band 16 QAM	1/#Mid	701.5	6.99	1.91	19.23	2.15	22.16	164.437	Vertical	Pass
		707.5	6.90	1.91	19.26	2.15	22.10	162.181	Vertical	Pass
		713.5	6.69	1.92	19.33	2.15	21.95	156.675	Vertical	Pass
10.0MHz Band 16 QAM	1/#Mid	704	7.01	1.91	19.25	2.15	<b>22.20</b>	165.959	Vertical	Pass
		707.5	6.99	1.91	19.26	2.15	22.19	165.577	Vertical	Pass
		711	6.84	1.92	19.32	2.15	22.09	161.808	Vertical	Pass
1.4MHz Band 16 QAM	1/#Mid	699.7	6.16	1.91	19.21	2.15	21.31	135.207	Horizontal	Pass
		707.5	5.79	1.91	19.26	2.15	20.99	125.603	Horizontal	Pass
		715.3	5.60	1.93	19.34	2.15	20.86	121.899	Horizontal	Pass
3.0MHz Band 16 QAM	1/#Mid	700.5	6.18	1.91	19.21	2.15	21.33	135.831	Horizontal	Pass
		707.5	5.40	1.91	19.26	2.15	20.60	114.815	Horizontal	Pass
		714.5	5.82	1.93	19.34	2.15	21.08	128.233	Horizontal	Pass
5.0MHz Band 16 QAM	1/#Mid	701.5	6.06	1.91	19.23	2.15	21.23	132.739	Horizontal	Pass
		707.5	5.40	1.91	19.26	2.15	20.60	114.815	Horizontal	Pass
		713.5	5.89	1.92	19.33	2.15	21.15	130.317	Horizontal	Pass
10.0MHz Band 16 QAM	1/#Mid	704	5.72	1.91	19.25	2.15	20.91	123.310	Horizontal	Pass
		707.5	5.95	1.91	19.26	2.15	21.15	130.317	Horizontal	Pass
		711	5.74	1.92	19.32	2.15	20.99	125.603	Horizontal	Pass

Note:

ERP=EIRP-2.15

SG Level= Signal generator output

Max. EIRP Average (dBm)= Antenna Factor (dB)+ SG Level (dBm)- Cable Loss(dBm)

### 8.7 LTE BAND 17

Radiated Power (ERP) for Band 17											
Mode	RB/RB SIZE	Frequency	Result							Polarization Of Max. ERP	Conclusion
			SG Level (dBm)	Cable Loss (dBm)	Antenna Factor (dB)	Correction (dB)	Max. EIRP Average (dBm)	Max. EIRP Average (mW)			
5.0MHz Band QPSK	1/#Mid	706.5	6.69	1.91	19.23	2.15	21.86	153.462	Vertical	Pass	
		710	6.55	1.91	19.26	2.15	21.75	149.624	Vertical	Pass	
		713.5	6.45	1.92	19.33	2.15	21.71	148.252	Vertical	Pass	
10.0MHz Band QPSK	1/#Mid	709	6.70	1.91	19.25	2.15	<b>21.89</b>	154.525	Vertical	Pass	
		710	6.65	1.91	19.26	2.15	21.85	153.109	Vertical	Pass	
		711	6.61	1.92	19.32	2.15	21.86	153.462	Vertical	Pass	
5.0MHz Band QPSK	1/#Mid	706.5	6.33	1.91	19.23	2.15	21.50	141.254	Horizontal	Pass	
		710	5.29	1.91	19.26	2.15	20.49	111.944	Horizontal	Pass	
		713.5	5.83	1.92	19.33	2.15	21.09	128.529	Horizontal	Pass	
10.0MHz Band QPSK	1/#Mid	709	5.92	1.91	19.25	2.15	21.11	129.122	Horizontal	Pass	
		710	5.90	1.91	19.26	2.15	21.10	128.825	Horizontal	Pass	
		711	4.81	1.92	19.32	2.15	20.06	101.391	Horizontal	Pass	

Radiated Power (ERP) for Band 17										
Mode	RB/RB SIZE	Frequency	Result							Conclusion
			SG Level (dBm)	Cable Loss (dBm)	Antenna Factor (dB)	Correction  (dB)	Max. EIRP	Max. EIRP	Polarization Of Max. ERP	
					Average		Average			
					(dBm)		(mW)			
5.0MHz Band 16 QAM	1/#Mid	706.5	6.19	1.91	19.23	2.15	21.36	136.773	Vertical	Pass
		710	6.10	1.91	19.26	2.15	21.30	134.896	Vertical	Pass
		713.5	5.90	1.92	19.33	2.15	21.16	130.617	Vertical	Pass
10.0MHz Band 16 QAM	1/#Mid	709	5.73	1.91	19.25	2.15	20.92	123.595	Vertical	Pass
		710	6.26	1.91	19.26	2.15	<b>21.46</b>	139.959	Vertical	Pass
		711	5.99	1.92	19.32	2.15	21.24	133.045	Vertical	Pass
5.0MHz Band 16 QAM	1/#Mid	706.5	5.40	1.91	19.23	2.15	20.57	114.025	Horizontal	Pass
		710	5.52	1.91	19.26	2.15	20.72	118.032	Horizontal	Pass
		713.5	4.69	1.92	19.33	2.15	19.95	98.855	Horizontal	Pass
10.0MHz Band 16 QAM	1/#Mid	709	5.36	1.91	19.25	2.15	20.55	113.501	Horizontal	Pass
		710	5.27	1.91	19.26	2.15	20.47	111.429	Horizontal	Pass
		711	4.58	1.92	19.32	2.15	19.83	96.161	Horizontal	Pass

Note:

ERP=EIRP-2.15

SG Level= Signal generator output

Max. EIRP Average (dBm)= Antenna Factor (dB)+ SG Level (dBm)- Cable Loss(dBm)

## 9. SPURIOUS RADIATION EMISSION

### RULE PART(S)

FCC: §2.1051, §22.917(a), §24.238(a), §27.53(c)(g)(h)(m)

### LIMIT

For Band 7, the minimum permissible attenuation level of any spurious emission is  $55 + \log_{10}(P)$  [Watts]).

The minimum permissible attenuation level of any spurious emission is  $43 + \log_{10}(P)$  [Watts]), where P is the transmitter power in Watts.

### TEST PROCEDURE

For Cellular equipment - Compliance with these rules is based on the use of measurement instrumentation employing a resolution bandwidth of 100 kHz or greater. In the 1 MHz bands immediately outside and adjacent to the frequency block a resolution bandwidth of at least one percent of the emission bandwidth of the fundamental emission of the transmitter may be employed. A narrower resolution bandwidth is permitted in all cases to improve measurement accuracy provided the measured power is integrated over the full required measurement bandwidth (i.e. 100 kHz or 1 percent of emission bandwidth, as specified). The emission bandwidth is defined as the width of the signal between two points, one below the carrier center frequency and one above the carrier center frequency, outside of which all emissions are attenuated at least 26 dB below the transmitter power.

For PCS equipment - Compliance with these rules is based on the use of measurement instrumentation employing a resolution bandwidth of 1 MHz or greater. However, in the 1 MHz bands immediately outside and adjacent to the frequency block a resolution bandwidth of at least one percent of the emission bandwidth of the fundamental emission of the transmitter may be employed. A narrower resolution bandwidth is permitted in all cases to improve measurement accuracy provided the measured power is integrated over the full required measurement bandwidth ( i.e. 1 MHz or 1 percent of emission bandwidth, as specified). The emission bandwidth is defined as the width of the signal between two points, one below the carrier center frequency and one above the carrier center frequency, outside of which all emissions are attenuated at least 26 dB below the transmitter power.

The unwanted emission power shall be measured with a resolution bandwidth of at least 1% of the occupied bandwidth in the 1 MHz band immediately outside and adjacent to the channel edge of the equipment. Beyond the 1 MHz band immediately outside the channel edge of the equipment, a resolution bandwidth of 1 MHz shall be employed. A narrower resolution bandwidth is allowed to be used provided that the measured power is integrated over the full required measurement bandwidth of 1 MHz or 1% of the occupied bandwidth as applicable.

The power of any unwanted emissions measured from the channel edge of the equipment shall be attenuated below the transmitter power, P (dBW), as follows:

- a. for base station and subscriber equipment, other than mobile subscriber equipment, the attenuation shall not be less than  $43 + 10 \text{ Log}_{10} (p)$ , dB; and
- b. for mobile subscriber equipment, the attenuation shall not be less than  $43 + 10 \text{ Log}_{10} (p)$ , dB at the channel edges and  $55 + 10 \text{ Log}_{10} (p)$  at 5.5 MHz away and beyond the channel edges where p in (a) and (b) is the transmitter power measured in watts.

#### **MODES TESTED**

- LTE Band2  
LTE Band 4
- LTE Band 5  
LTE Band 7  
LTE Band 12  
LTE Band 17

#### **RESULTS**

PASS

## 9.1 LTE BAND 2

### QPSK EIRP POWER FOR LTE BAND 2 (1.4MHZ BANDWIDTH)

Test Results for Low Channel 1850.7MHz							
Frequency(MHz)	SG Level(dBm)	Cable Loss(dB)	Antenna Factor(dB)	Absolute Level(dBm)	Limit ( dBm )	Margin(dBm)	Polarity
3701.4	-50.96	4.04	33.51	-21.49	-13	-8.49	Horizontal
3701.4	-53.89	4.04	33.51	-24.42	-13	-11.42	Vertical
5552.1	-48.86	5.24	35.84	-18.26	-13	-5.26	Vertical
5552.1	-49.15	5.24	35.84	-18.55	-13	-5.55	Horizontal
193.9	-39.85	1.43	16.02	-25.26	-13	-12.26	Vertical
469.4	-37.19	1.30	17.99	-20.50	-13	-7.50	Horizontal
Test Results for Mid Channel 1880MHz							
3760.0	-44.59	4.04	33.56	-15.07	-13	-2.07	Horizontal
3760.0	-48.65	4.04	33.56	-19.13	-13	-6.13	Vertical
5640.0	-51.19	5.24	35.91	-20.52	-13	-7.52	Vertical
5640.0	-51.55	5.24	35.91	-20.88	-13	-7.88	Horizontal
208.0	-43.81	1.62	16.97	-28.46	-13	-15.46	Vertical
391.0	-36.92	1.74	15.98	-22.69	-13	-9.69	Horizontal
Test Results for High Channel 1909.3MHz							
3818.6	-46.90	4.04	34.00	-16.94	-13	-3.94	Horizontal
3818.6	-45.40	4.04	34.00	-15.44	-13	-2.44	Vertical
5727.9	-45.58	5.24	36.04	-14.78	-13	-1.78	Vertical
5727.9	-51.94	5.24	36.04	-21.14	-13	-8.14	Horizontal
175.1	-38.60	1.42	17.29	-22.73	-13	-9.73	Vertical
316.0	-40.43	1.50	17.90	-24.02	-13	-11.02	Horizontal

**QPSK EIRP POWER FOR LTE BAND 2 (20.0MHZ BANDWIDTH)**

Test Results for Low Channel 1860MHz							
Frequency(MHz)	SG Level(dBm)	Cable Loss(dB)	Antenna Factor(dB)	Absolute Level(dBm)	Limit (dBm)	Margin(dBm)	Polarity
3720.0	-48.40	4.07	33.54	-18.93	-13	-5.93	Horizontal
3720.0	-45.20	4.07	33.54	-15.73	-13	-2.73	Vertical
5580.0	-51.30	5.28	35.86	-20.72	-13	-7.72	Vertical
5580.0	-49.90	5.28	35.86	-19.32	-13	-6.32	Horizontal
186.0	-43.54	1.58	16.89	-28.22	-13	-15.22	Vertical
360.9	-36.15	1.76	17.26	-20.65	-13	-7.65	Horizontal
Test Results for Mid Channel 1880MHz							
3760.0	-46.43	4.04	33.56	-16.91	-13	-3.91	Horizontal
3760.0	-44.39	4.04	33.56	-14.87	-13	-1.87	Vertical
5640.0	-52.78	5.24	35.91	-22.11	-13	-9.11	Vertical
5640.0	-50.87	5.24	35.91	-20.20	-13	-7.20	Horizontal
184.7	-35.27	1.46	16.27	-20.46	-13	-7.46	Vertical
238.2	-37.90	1.59	15.15	-24.34	-13	-11.34	Horizontal
Test Results for High Channel 1900MHz							
3800.0	-50.70	4.04	34.00	-20.74	-13	-7.74	Horizontal
3800.0	-50.06	4.04	34.00	-20.10	-13	-7.10	Vertical
5700.0	-51.75	5.24	36.04	-20.95	-13	-7.95	Vertical
5700.0	-53.91	5.24	36.04	-23.11	-13	-10.11	Horizontal
183.0	-35.18	1.36	17.39	-19.14	-13	-6.14	Vertical
455.3	-44.63	1.66	15.39	-30.90	-13	-17.90	Horizontal

**Note:** Spurious Emission Level = Spectrum Analyzer Read Value + Cable Loss+ Antenna Factor + 11.74  
 . Margin = Spurious Emission Level - Limit  
 . Both QPSK and 16QAM has been tested, the worst case is QPSK mode, the report just reported the worst case.



## 9.2 LTE BAND 4

### QPSK EIRP POWER FOR LTE BAND 4 (1.4MHZ BANDWIDTH)

Test Results for Low Channel 1710.7MHz							
Frequency(MHz)	SG Level(dBm)	Cable Loss(dB)	Antenna Factor(dB)	Absolute Level(dBm)	Limit (dBm)	Margin(dBm)	Polarity
3421.4	-46.02	4.02	29.80	-20.24	-13	-7.24	Horizontal
3421.4	-44.26	4.02	29.80	-18.48	-13	-5.48	Vertical
5132.1	-53.20	5.24	35.84	-22.60	-13	-9.60	Vertical
5132.1	-50.41	5.24	35.84	-19.81	-13	-6.81	Horizontal
189.3	-37.31	1.68	16.04	-22.95	-13	-9.95	Vertical
270.4	-41.29	1.78	17.74	-25.33	-13	-12.33	Horizontal
Test Results for Mid Channel 1732.5MHz							
3465.0	-45.02	4.03	30.00	-19.05	-13	-6.05	Horizontal
3465.0	-48.72	4.03	30.00	-22.75	-13	-9.75	Vertical
5197.5	-51.76	5.25	35.86	-21.15	-13	-8.15	Vertical
5197.5	-49.06	5.25	35.86	-18.45	-13	-5.45	Horizontal
191.1	-40.49	1.72	17.69	-24.52	-13	-11.52	Vertical
278.7	-34.18	1.62	16.02	-19.77	-13	-6.77	Horizontal
Test Results for High Channel 1754.3MHz							
3508.6	-49.01	4.05	30.01	-23.05	-13	-10.05	Horizontal
3508.6	-51.54	4.05	30.01	-25.58	-13	-12.58	Vertical
5262.9	-51.40	5.26	35.86	-20.80	-13	-7.80	Vertical
5262.9	-53.66	5.26	35.86	-23.06	-13	-10.06	Horizontal
175.8	-34.40	1.80	16.69	-19.51	-13	-6.51	Vertical
380.3	-34.80	1.75	16.66	-19.90	-13	-6.90	Horizontal

**QPSK EIRP POWER FOR LTE BAND 4 (20.0MHZ BANDWIDTH)**

Test Results for Low Channel 1720MHz							
Frequency(MHz)	SG Level(dBm)	Cable Loss(dB)	Antenna Factor(dB)	Absolute Level(dBm)	Limit (dBm)	Margin(dBm)	Polarity
3440.0	-47.47	4.02	29.80	-21.69	-13	-8.69	Horizontal
3440.0	-51.92	4.02	29.80	-26.14	-13	-13.14	Vertical
5160.0	-50.83	5.24	35.84	-20.23	-13	-7.23	Vertical
5160.0	-52.11	5.24	35.84	-21.51	-13	-8.51	Horizontal
181.5	-43.12	1.57	17.26	-27.43	-13	-14.43	Vertical
316.5	-34.33	1.78	16.35	-19.76	-13	-6.76	Horizontal
Test Results for Mid Channel 1732.5MHz							
3465.0	-48.89	4.03	30.00	-22.92	-13	-9.92	Horizontal
3465.0	-53.22	4.03	30.00	-27.25	-13	-14.25	Vertical
5197.5	-46.46	5.25	35.86	-15.85	-13	-2.85	Vertical
5197.5	-50.76	5.25	35.86	-20.15	-13	-7.15	Horizontal
189.1	-36.98	1.44	17.95	-20.47	-13	-7.47	Vertical
430.4	-36.17	1.65	16.09	-21.73	-13	-8.73	Horizontal
Test Results for High Channel 1745MHz							
3490.0	-49.55	2.91	27.68	-24.78	-13	-11.78	Horizontal
3490.0	-45.25	2.91	27.68	-20.48	-13	-7.48	Vertical
5235.0	-51.80	5.26	35.86	-21.20	-13	-8.20	Vertical
5235.0	-53.66	5.26	35.86	-23.06	-13	-10.06	Horizontal
191.5	-44.16	1.61	16.85	-28.92	-13	-15.92	Vertical
290.7	-38.50	1.61	15.19	-24.92	-13	-11.92	Horizontal

Note: Spurious Emission Level = Spectrum Analyzer Read Value + Cable Loss+ Antenna Factor + 11.74

. Margin = Spurious Emission Level - Limit

. Both QPSK and 16QAM has been tested, the worst case is QPSK mode, the report just reported the worst case.

**9.3 LTE BAND 5**  
**QPSK EIRP POWER FOR LTE BAND 5 (1.4MHZ BANDWIDTH)**

Test Results for Low Channel 824.7MHz							
Frequency(MHz)	SG Level(dBm)	Cable Loss(dB)	Antenna Factor(dB)	Absolute Level(dBm)	Limit (dBm)	Margin(dBm)	Polarity
1649.4	-50.26	2.78	27.50	-25.54	-13	-12.54	Horizontal
1649.4	-50.13	2.78	27.50	-25.41	-13	-12.41	Vertical
2474.1	-53.72	2.90	27.80	-28.82	-13	-15.82	Vertical
2474.1	-49.83	2.90	27.80	-24.93	-13	-11.93	Horizontal
205.9	-40.61	1.76	17.59	-24.78	-13	-11.78	Vertical
319.3	-39.62	1.63	15.87	-25.38	-13	-12.38	Horizontal
Test Results For Mid Channel 836.5MHz							
1673.0	-46.51	2.80	27.48	-21.83	-13	-8.83	Horizontal
1673.0	-44.70	2.80	27.48	-20.02	-13	-7.02	Vertical
2509.5	-45.23	2.91	27.70	-20.44	-13	-7.44	Vertical
2509.5	-49.42	2.91	27.70	-24.63	-13	-11.63	Horizontal
193.0	-38.70	1.61	15.68	-24.63	-13	-11.63	Vertical
376.8	-43.55	1.59	17.52	-27.63	-13	-14.63	Horizontal
Test Results for High Channel 848.3MHz							
1696.6	-49.57	2.82	27.43	-24.96	-13	-11.96	Horizontal
1696.6	-52.71	2.82	27.43	-28.10	-13	-15.10	Vertical
2544.9	-50.64	2.92	27.74	-25.82	-13	-12.82	Vertical
2544.9	-51.45	2.92	27.74	-26.63	-13	-13.63	Horizontal
191.6	-41.33	1.69	16.67	-26.34	-13	-13.34	Vertical
367.4	-38.34	1.70	17.18	-22.86	-13	-9.86	Horizontal

**QPSK EIRP POWER FOR LTE BAND 5 (10MHZ BANDWIDTH)**

Test Results for Low Channel 829MHz							
Frequency(MHz)	SG Level(dBm)	Cable Loss(dB)	Antenna Factor(dB)	Absolute Level(dBm)	Limit (dBm)	Margin(dBm)	Polarity
1658.0	-48.96	2.78	27.50	-24.24	-13	-11.24	Horizontal
1658.0	-47.84	2.78	27.50	-23.12	-13	-10.12	Vertical
2487.0	-46.28	2.90	27.80	-21.38	-13	-8.38	Vertical
2487.0	-50.97	2.90	27.80	-26.07	-13	-13.07	Horizontal
188.4	-40.35	1.71	15.57	-26.49	-13	-13.49	Vertical
263.0	-41.88	1.34	16.40	-26.82	-13	-13.82	Horizontal
Test Results for Mid Channel 836.5MHz							
1673.0	-46.70	2.80	27.48	-22.02	-13	-9.02	Horizontal
1673.0	-49.55	2.80	27.48	-24.87	-13	-11.87	Vertical
2509.5	-46.27	2.91	27.70	-21.48	-13	-8.48	Vertical
2509.5	-49.26	2.91	27.70	-24.47	-13	-11.47	Horizontal
191.8	-38.03	1.44	17.04	-22.43	-13	-9.43	Vertical
455.3	-36.15	1.76	17.62	-20.29	-13	-7.29	Horizontal
Test Results for High Channel 844MHz							
1688.0	-50.75	2.82	27.43	-26.14	-13	-13.14	Horizontal
1688.0	-50.75	2.82	27.43	-26.14	-13	-13.14	Vertical
2532.0	-46.75	2.92	27.74	-21.93	-13	-8.93	Vertical
2532.0	-49.91	2.92	27.74	-25.09	-13	-12.09	Horizontal
191.3	-36.00	1.74	17.70	-20.04	-13	-7.04	Vertical
370.0	-44.82	1.41	17.46	-28.76	-13	-15.76	Horizontal

Note: Spurious Emission Level = Spectrum Analyzer Read Value + Cable Loss+ Antenna Factor + 11.74

. Margin = Spurious Emission Level - Limit

. Both QPSK and 16QAM has been tested, the worst case is QPSK mode, the report just reported the worst case.

### 9.4 LTE BAND 7

#### QPSK EIRP POWER FOR LTE BAND 7 (5.0MHZ BANDWIDTH)

Test Results for Low Channel 2502.5MHz							
Frequency(MHz)	SG Level(dBm)	Cable Loss(dB)	Antenna Factor(dB)	Absolute Level(dBm)	Limit (dBm)	Margin(dBm)	Polarity
5005.0	-63.35	5.23	35.81	-32.77	-25	-7.77	Horizontal
5005.0	-63.33	5.23	35.81	-32.75	-25	-7.75	Vertical
7507.5	-60.49	5.67	36.85	-29.31	-25	-4.31	Vertical
7507.5	-64.78	5.67	36.85	-33.60	-25	-8.60	Horizontal
180.4	-44.01	1.73	17.97	-27.77	-25	-2.77	Vertical
410.9	-46.40	1.38	15.11	-32.67	-25	-7.67	Horizontal
Test Results for Mid Channel 2535MHz							
5070.0	-59.68	5.23	35.82	-29.09	-25	-4.09	Horizontal
5070.0	-62.89	5.23	35.82	-32.30	-25	-7.30	Vertical
7605.0	-59.32	5.67	36.85	-28.14	-25	-3.14	Vertical
7605.0	-60.89	5.67	36.85	-29.71	-25	-4.71	Horizontal
211.9	-49.54	1.77	16.17	-35.13	-25	-10.13	Vertical
440.6	-53.57	1.63	15.21	-39.99	-25	-14.99	Horizontal
Test Results for High Channel 2567.5MHz							
5135.0	-63.59	5.24	35.83	-33.00	-25	-8.00	Horizontal
5135.0	-63.21	5.24	35.83	-32.62	-25	-7.62	Vertical
7702.5	-59.90	5.68	36.87	-28.71	-25	-3.71	Vertical
7702.5	-61.83	5.68	36.87	-30.64	-25	-5.64	Horizontal
195.3	-54.67	1.58	17.56	-38.69	-25	-13.69	Vertical
344.6	-54.73	1.45	16.58	-39.60	-25	-14.60	Horizontal

**QPSK EIRP POWER FOR LTE BAND 7 (20.0MHZ BANDWIDTH)**

Test Results for Low Channel 2510MHz							
Frequency(MHz)	SG Level(dBm)	Cable Loss(dB)	Antenna Factor(dB)	Absolute Level(dBm)	Limit (dBm)	Margin(dBm)	Polarity
5020.0	-64.84	5.23	35.82	-34.25	-25	-9.25	Horizontal
5020.0	-60.83	5.23	35.82	-30.24	-25	-5.24	Vertical
7530.0	-63.79	5.67	36.86	-32.60	-25	-7.60	Vertical
7530.0	-59.47	5.67	36.86	-28.28	-25	-3.28	Horizontal
200.2	-53.12	1.63	15.76	-38.99	-25	-13.99	Vertical
247.9	-53.22	1.71	15.44	-39.49	-25	-14.49	Horizontal
Test Results for Mid Channel 2535MHz							
5070.0	-63.42	5.23	35.82	-32.83	-25	-7.83	Horizontal
5070.0	-63.29	5.23	35.82	-32.70	-25	-7.70	Vertical
7605.0	-63.31	5.67	36.85	-32.13	-25	-7.13	Vertical
7605.0	-64.93	5.67	36.85	-33.75	-25	-8.75	Horizontal
212.0	-54.18	1.79	16.84	-39.12	-25	-14.12	Vertical
349.6	-53.33	1.71	17.64	-37.40	-25	-12.40	Horizontal
Test Results for High Channel 2560MHz							
5120.0	-63.81	5.24	35.83	-33.22	-25	-8.22	Horizontal
5120.0	-61.25	5.24	35.83	-30.66	-25	-5.66	Vertical
7680.0	-63.50	5.70	36.88	-32.32	-25	-7.32	Vertical
7680.0	-64.02	5.70	36.88	-32.84	-25	-7.84	Horizontal
202.9	-46.95	1.79	16.84	-31.89	-25	-6.89	Vertical
305.0	-48.04	1.71	17.64	-32.11	-25	-7.11	Horizontal

Note: Spurious Emission Level = Spectrum Analyzer Read Value + Cable Loss+ Antenna Factor + 11.74  
 . Margin = Spurious Emission Level - Limit  
 . Both QPSK and 16QAM has been tested, the worst case is QPSK mode, the report just reported the worst case.

### 9.5 LTE BAND 12

#### QPSK EIRP POWER FOR LTE BAND 12 (1.4MHZ BANDWIDTH)

Test Results for Low Channel 699.7MHz							
Frequency(MHz)	SG Level(dBm)	Cable Loss(dB)	Antenna Factor(dB)	Absolute Level(dBm)	Limit (dBm)	Margin(dBm)	Polarity
1399.4	-47.60	2.60	27.20	-23.00	-13	-10.00	Horizontal
1399.4	-50.59	2.60	27.20	-25.99	-13	-12.99	Vertical
2099.1	-44.20	2.85	27.54	-19.51	-13	-6.51	Vertical
2099.1	-53.16	2.85	27.54	-28.47	-13	-15.47	Horizontal
200.1	-39.58	1.49	17.78	-23.29	-13	-10.29	Vertical
393.8	-41.00	1.36	17.33	-25.03	-13	-12.03	Horizontal
Test Results For Mid Channel 707.5MHz							
1415.0	-45.36	2.61	27.28	-20.69	-13	-7.69	Horizontal
1415.0	-46.15	2.61	27.28	-21.48	-13	-8.48	Vertical
2122.5	-47.16	2.87	27.59	-22.44	-13	-9.44	Vertical
2122.5	-49.55	2.87	27.59	-24.83	-13	-11.83	Horizontal
181.8	-43.76	1.73	15.74	-29.75	-13	-16.75	Vertical
278.4	-43.29	1.62	15.79	-29.12	-13	-16.12	Horizontal
Test Results for High Channel 715.3MHz							
1430.6	-52.06	2.63	27.28	-27.41	-13	-14.41	Horizontal
1430.6	-51.50	2.63	27.28	-26.85	-13	-13.85	Vertical
2145.9	-49.12	2.88	27.60	-24.40	-13	-11.40	Vertical
2145.9	-51.77	2.88	27.60	-27.05	-13	-14.05	Horizontal
177.9	-43.76	1.61	18.00	-27.37	-13	-14.37	Vertical
263.9	-38.80	1.45	15.49	-24.77	-13	-11.77	Horizontal

**QPSK EIRP POWER FOR LTE BAND 12 (10MHZ BANDWIDTH)**

Test Results for Low Channel 704MHz							
Frequency(MHz)	SG Level(dBm)	Cable Loss(dB)	Antenna Factor(dB)	Absolute Level(dBm)	Limit (dBm)	Margin(dBm)	Polarity
1408.0	-44.56	2.61	27.26	-19.91	-13	-6.91	Horizontal
1408.0	-53.22	2.61	27.26	-28.57	-13	-15.57	Vertical
2112.0	-44.06	2.87	27.58	-19.35	-13	-6.35	Vertical
2112.0	-52.83	2.87	27.58	-28.12	-13	-15.12	Horizontal
184.7	-44.30	1.31	16.97	-28.64	-13	-15.64	Vertical
262.5	-39.19	1.65	16.70	-24.14	-13	-11.14	Horizontal
Test Results for Mid Channel 707.5MHz							
1415.0	-52.91	2.61	27.28	-28.24	-13	-15.24	Horizontal
1415.0	-49.06	2.61	27.28	-24.39	-13	-11.39	Vertical
2122.5	-52.93	2.87	27.59	-28.21	-13	-15.21	Vertical
2122.5	-51.62	2.87	27.59	-26.90	-13	-13.90	Horizontal
187.6	-37.52	1.72	17.99	-21.25	-13	-8.25	Vertical
331.8	-41.16	1.73	17.94	-24.95	-13	-11.95	Horizontal
Test Results for High Channel 711MHz							
1422.0	-46.92	2.62	27.28	-22.26	-13	-9.26	Horizontal
1422.0	-53.67	2.62	27.28	-29.01	-13	-16.01	Vertical
2133.0	-45.44	2.87	27.60	-20.71	-13	-7.71	Vertical
2133.0	-52.84	2.87	27.60	-28.11	-13	-15.11	Horizontal
204.0	-37.16	1.58	15.93	-22.81	-13	-9.81	Vertical
421.3	-41.96	1.36	15.59	-27.73	-13	-14.73	Horizontal

Note: Spurious Emission Level = Spectrum Analyzer Read Value + Cable Loss+ Antenna Factor + 11.74  
 . Margin = Spurious Emission Level - Limit  
 . Both QPSK and 16QAM has been tested, the worst case is QPSK mode, the report just reported the worst case



9.6 LTE BAND 17

**QPSK EIRP POWER FOR LTE BAND 17 (5MHZ BANDWIDTH)**

Test Results for Low Channel 706.5MHz							
Frequency(MHz)	SG Level(dBm)	Cable Loss(dB)	Antenna Factor(dB)	Absolute Level(dBm)	Limit (dBm)	Margin(dBm)	Polarity
1413.0	-46.55	2.61	27.28	-21.88	-13	-8.88	Horizontal
1413.0	-49.87	2.61	27.28	-25.20	-13	-12.20	Vertical
2119.5	-53.36	2.87	27.59	-28.64	-13	-15.64	Vertical
2119.5	-53.73	2.87	27.59	-29.01	-13	-16.01	Horizontal
202.7	-34.02	1.71	16.15	-19.58	-13	-6.58	Vertical
233.3	-35.69	1.41	17.32	-19.78	-13	-6.78	Horizontal
Test Results For Mid Channel 710MHz							
1420.0	-49.70	2.62	27.30	-25.02	-13	-12.02	Horizontal
1420.0	-47.22	2.62	27.30	-22.54	-13	-9.54	Vertical
2130.0	-44.98	2.87	27.62	-20.23	-13	-7.23	Vertical
2130.0	-49.40	2.87	27.62	-24.65	-13	-11.65	Horizontal
204.7	-41.88	1.42	15.25	-28.06	-13	-15.06	Vertical
234.9	-39.55	1.36	17.19	-23.72	-13	-10.72	Horizontal
Test Results for High Channel 713.5MHz							
1427.0	-48.40	2.66	27.28	-23.78	-13	-10.78	Horizontal
1427.0	-53.72	2.66	27.28	-29.10	-13	-16.10	Vertical
2140.5	-47.38	2.88	27.60	-22.66	-13	-9.66	Vertical
2140.5	-49.21	2.88	27.60	-24.49	-13	-11.49	Horizontal
186.6	-39.91	1.32	17.29	-23.94	-13	-10.94	Vertical
320.6	-34.85	1.72	16.89	-19.68	-13	-6.68	Horizontal

**QPSK EIRP POWER FOR LTE BAND 17 (10MHZ BANDWIDTH)**

Test Results for Low Channel 709MHz							
Frequency(MHz)	SG Level(dBm)	Cable Loss(dB)	Antenna Factor(dB)	Absolute Level(dBm)	Limit (dBm)	Margin(dBm)	Polarity
1418.0	-44.55	2.62	27.30	-19.87	-13	-6.87	Horizontal
1418.0	-49.05	2.62	27.30	-24.37	-13	-11.37	Vertical
2127.0	-45.28	2.87	27.62	-20.53	-13	-7.53	Vertical
2127.0	-51.64	2.87	27.62	-26.89	-13	-13.89	Horizontal
181.9	-40.32	1.35	16.91	-24.76	-13	-11.76	Vertical
400.3	-42.94	1.62	16.31	-28.25	-13	-15.25	Horizontal
Test Results for Mid Channel 710MHz							
1420.0	-48.38	2.62	27.30	-23.70	-13	-10.70	Horizontal
1420.0	-46.41	2.62	27.30	-21.73	-13	-8.73	Vertical
2130.0	-46.42	2.87	27.62	-21.67	-13	-8.67	Vertical
2130.0	-51.19	2.87	27.62	-26.44	-13	-13.44	Horizontal
200.7	-40.15	1.51	17.14	-24.52	-13	-11.52	Vertical
232.4	-40.54	1.77	16.88	-25.43	-13	-12.43	Horizontal
Test Results for High Channel 711MHz							
1422.0	-46.65	2.62	27.30	-21.97	-13	-8.97	Horizontal
1422.0	-50.48	2.62	27.30	-25.80	-13	-12.80	Vertical
2133.0	-49.55	2.87	27.62	-24.80	-13	-11.80	Vertical
2133.0	-51.95	2.87	27.62	-27.20	-13	-14.20	Horizontal
193.9	-35.20	1.78	15.95	-21.03	-13	-8.03	Vertical
421.9	-38.27	1.34	17.95	-21.67	-13	-8.67	Horizontal

Note: Spurious Emission Level = Spectrum Analyzer Read Value + Cable Loss+ Antenna Factor + 11.74  
 . Margin = Spurious Emission Level - Limit  
 . Both QPSK and 16QAM has been tested, the worst case is QPSK mode, the report just reported the worst case.

## 10. FREQUENCY STABILITY

### RULE PART(S)

FCC: §2.1055, §22.355, §24.235, §27.54

### LIMITS

§22.355 - The carrier frequency shall not depart from the reference frequency in excess of  $\pm 2.5$  ppm for mobile stations.

§24.235 - The frequency stability shall be sufficient to ensure that the fundamental emission stays within the authorized frequency block.

### TEST PROCEDURE

Use CMW 500 with Frequency Error measurement capability.

- Temp. =  $-30^{\circ}$  to  $+50^{\circ}\text{C}$
- Voltage = low voltage, DC 34V, Normal, DC 3.85V and High voltage, DC 4.2V.

### Frequency Stability vs Temperature:

The EUT is placed inside a temperature chamber. The temperature is set to  $-30^{\circ}\text{C}$  and allowed to stabilize. After sufficient soak time, the transmitting frequency error is measured. The temperature is increased by 10 degrees, allowed to stabilize and soak, and then the measurement is repeated. This is repeated until  $+50^{\circ}\text{C}$  is reached.

### Frequency Stability vs Voltage:

The peak frequency error is recorded (worst-case).

### MODES TESTED

- LTE Band2  
LTE Band 4
- LTE Band5  
LTE Band 7  
LTE Band 12  
LTE Band 17

## RESULTS

See the following pages.

10.1 LTE BAND 2

**Band 2 QPSK, (20MHz BANDWIDTH RB size 100 RB Offset 0)**

**Frequency error vs. Voltage**

Voltage [Vdc]	Frequency [MHz]	Frequency* Error[Hz]	Frequency Error[ppm]	Limit [ppm]
3.4	1880	12.5	0.006649	2.5
3.85	1880	14.2	0.007546	2.5
4.2	1880	13.6	0.007243	2.5

**Frequency error vs. Temperature**

Temperature [° C]	Frequency [MHz]	Frequency* Error[Hz]	Frequency Error[ppm]	Limit [ppm]
Normal (25C)	1880	13.1	0.006963	2.5
Extreme (50C)	1880	11.6	0.006177	2.5
Extreme (40C)	1880	14.0	0.007466	2.5
Extreme (30C)	1880	13.5	0.007166	2.5
Extreme (10C)	1880	13.8	0.007336	2.5
Extreme (0C)	1880	12.5	0.006632	2.5
Extreme (-10C)	1880	13.3	0.007066	2.5
Extreme (-20C)	1880	13.7	0.007263	2.5
Extreme (-30C)	1880	15.2	0.008084	2.5

**Band 2 16QAM, (20MHz BANDWIDTH RB size 100 RB Offset 0)**

**Frequency error vs. Voltage**

Voltage [Vdc]	Frequency [MHz]	Frequency* Error[Hz]	Frequency Error[ppm]	Limit [ppm]
3.4	1880	9.9	0.005245	2.5
3.85	1880	8.9	0.004738	2.5
4.2	1880	8.4	0.004451	2.5

**Frequency error vs. Temperature**

Temperature [° C]	Frequency [MHz]	Frequency* Error[Hz]	Frequency Error[ppm]	Limit [ppm]
Normal (25C)	1880	9.6	0.005112	2.5
Extreme (50C)	1880	9.4	0.005000	2.5
Extreme (40C)	1880	8.3	0.004428177	2.5
Extreme (30C)	1880	9.0	0.004813035	2.5
Extreme (10C)	1880	9.2	0.004917721	2.5
Extreme (0C)	1880	8.0	0.00423847	2.5
Extreme (-10C)	1880	9.0	0.004790038	2.5
Extreme (-20C)	1880	9.0	0.004812913	2.5
Extreme (-30C)	1880	8.0	0.004259114	2.5

\*Note: Frequency error measurements were made by using the build-in capability of the Wireless Communication Test Set.

10.2 LTE BAND 4

**Band 4 QPSK, (20MHz BANDWIDTH RB size 100 RB Offset 0)**

**Frequency error vs. Voltage**

Voltage [Vdc]	Frequency [MHz]	Frequency* Error[Hz]	Frequency Error[ppm]	Limit [ppm]
3.4	1732.5	9.0	0.005211	2.5
3.85	1732.5	8.9	0.005158	2.5
4.2	1732.5	8.3	0.004790	2.5

**Frequency error vs. Temperature**

Temperature [°C]	Frequency [MHz]	Frequency* Error[Hz]	Frequency Error[ppm]	Limit [ppm]
Normal (25C)	1732.5	8.7	0.005049	2.5
Extreme (50C)	1732.5	8.7	0.005040	2.5
Extreme (40C)	1732.5	7.0	0.004021	2.5
Extreme (30C)	1732.5	5.6	0.003226	2.5
Extreme (10C)	1732.5	7.0	0.004038	2.5
Extreme (0C)	1732.5	9.5	0.005507	2.5
Extreme (-10C)	1732.5	8.2	0.004740	2.5
Extreme (-20C)	1732.5	6.9	0.004009	2.5
Extreme (-30C)	1732.5	8.0	0.004646	2.5

**Band 4 16QAM, (20MHz BANDWIDTH RB size 100 RB Offset 0)**

**Frequency error vs. Voltage**

Voltage [Vdc]	Frequency [MHz]	Frequency* Error[Hz]	Frequency Error[ppm]	Limit [ppm]
3.4	1732.5	10.2	0.005886	2.5
3.85	1732.5	9.3	0.005394	2.5
4.2	1732.5	8.0	0.004599	2.5

**Frequency error vs. Temperature**

Temperature [°C]	Frequency [MHz]	Frequency* Error[Hz]	Frequency Error[ppm]	Limit [ppm]
Normal (25C)	1732.5	10.1	0.005845	2.5
Extreme (50C)	1732.5	8.9	0.005124	2.5
Extreme (40C)	1732.5	7.8	0.004510	2.5
Extreme (30C)	1732.5	8.6	0.004992	2.5
Extreme (10C)	1732.5	8.7	0.005034	2.5
Extreme (0C)	1732.5	8.5	0.004898	2.5
Extreme (-10C)	1732.5	9.1	0.005281	2.5
Extreme (-20C)	1732.5	8.8	0.005081	2.5
Extreme (-30C)	1732.5	7.7	0.004454	2.5

**\*Note:** Frequency error measurements were made by using the build-in capability of the Wireless Communication Test Set.

10.3 LTE BAND 5

**Band 5 QPSK, (10MHz BANDWIDTH RB size 50 RB Offset 0)**

**Frequency error vs. Voltage**

Voltage [Vdc]	Frequency [MHz]	Frequency* Error[Hz]	Frequency Error[ppm]	Limit [ppm]
3.4	836.5	5.9	0.007004	2.5
3.85	836.5	6.6	0.007926	2.5
4.2	836.5	4.4	0.005202	2.5

**Frequency error vs. Temperature**

Temperature [° C]	Frequency [MHz]	Frequency* Error[Hz]	Frequency Error[ppm]	Limit [ppm]
Normal (25C)	836.5	5.6	0.006709	2.5
Extreme (50C)	836.5	6.0	0.007189	2.5
Extreme (40C)	836.5	5.9	0.007096	2.5
Extreme (30C)	836.5	6.0	0.007144	2.5
Extreme (10C)	836.5	5.4	0.006497	2.5
Extreme (0C)	836.5	5.5	0.006633	2.5
Extreme (-10C)	836.5	6.1	0.007268	2.5
Extreme (-20C)	836.5	6.1	0.007299	2.5
Extreme (-30C)	836.5	6.1	0.007268	2.5



**Band 5 16QAM, (10MHz BANDWIDTH RB size 50 RB Offset 0)**

**Frequency error vs. Voltage**

Voltage [Vdc]	Frequency [MHz]	Frequency* Error[Hz]	Frequency Error[ppm]	Limit [ppm]
3.4	836.5	5.7	0.006843	2.5
3.85	836.5	7.0	0.008365	2.5
4.2	836.5	5.2	0.006257	2.5

**Frequency error vs. Temperature**

Temperature [° C]	Frequency [MHz]	Frequency* Error[Hz]	Frequency Error[ppm]	Limit [ppm]
Normal (25C)	836.5	6.6	0.007845	2.5
Extreme (50C)	836.5	5.8	0.006946	2.5
Extreme (40C)	836.5	5.9	0.007019	2.5
Extreme (30C)	836.5	6.1	0.007274	2.5
Extreme (10C)	836.5	5.8	0.006946	2.5
Extreme (0C)	836.5	4.8	0.005781	2.5
Extreme (-10C)	836.5	5.7	0.006778	2.5
Extreme (-20C)	836.5	6.4	0.007703	2.5
Extreme (-30C)	836.5	6.3	0.007514	2.5

**\*Note:** Frequency error measurements were made by using the build-in capability of the Wireless Communication Test Set.

10.4 LTE BAND 7

**Band 7 QPSK, (20MHz BANDWIDTH RB size 100 RB Offset 0)**

**Frequency error vs. Voltage**

Voltage [Vdc]	Frequency [MHz]	Frequency* Error[Hz]	Frequency Error[ppm]	Limit [ppm]
3.4	2535	9.6	0.003780	2.5
3.85	2535	9.0	0.003569	2.5
4.2	2535	8.7	0.003438	2.5

**Frequency error vs. Temperature**

Temperature [° C]	Frequency [MHz]	Frequency* Error[Hz]	Frequency Error[ppm]	Limit [ppm]
Normal (25C)	2535	9.4	0.003690	2.5
Extreme (50C)	2535	9.1	0.003580	2.5
Extreme (40C)	2535	8.7	0.003441	2.5
Extreme (30C)	2535	9.0	0.003536	2.5
Extreme (10C)	2535	8.2	0.003238	2.5
Extreme (0C)	2535	8.4	0.003304	2.5
Extreme (-10C)	2535	9.9	0.003894	2.5
Extreme (-20C)	2535	8.7	0.003445	2.5
Extreme (-30C)	2535	8.4	0.003317	2.5

**Band 7 16QAM, (20MHz BANDWIDTH RB size 100 RB Offset 0)**

**Frequency error vs. Voltage**

Voltage [Vdc]	Frequency [MHz]	Frequency* Error[Hz]	Frequency Error[ppm]	Limit [ppm]
3.4	2535	6.9	0.002722	2.5
3.85	2535	6.3	0.002473	2.5
4.2	2535	5.8	0.002294	2.5

**Frequency error vs. Temperature**

Temperature [° C]	Frequency [MHz]	Frequency* Error[Hz]	Frequency Error[ppm]	Limit [ppm]
Normal (25C)	2535	6.7	0.002637	2.5
Extreme (50C)	2535	5.7	0.002238	2.5
Extreme (40C)	2535	5.9	0.002309	2.5
Extreme (30C)	2535	6.5	0.002581	2.5
Extreme (10C)	2535	5.6	0.002222	2.5
Extreme (0C)	2535	5.1	0.001995	2.5
Extreme (-10C)	2535	4.8	0.001900	2.5
Extreme (-20C)	2535	6.1	0.002394	2.5
Extreme (-30C)	2535	5.3	0.002095	2.5

**\*Note:** Frequency error measurements were made by using the build-in capability of the Wireless Communication Test Set.

10.5 LTE BAND 12

**Band 12 QPSK, (10MHz BANDWIDTH RB size 50 RB Offset 0)**

**Frequency error vs. Voltage**

Voltage [Vdc]	Frequency [MHz]	Frequency* Error[Hz]	Frequency Error[ppm]	Limit [ppm]
3.4	707.5	8.7	0.012348	2.5
3.85	707.5	10.4	0.014653	2.5
4.2	707.5	8.7	0.012302	2.5

**Frequency error vs. Temperature**

Temperature [° C]	Frequency [MHz]	Frequency* Error[Hz]	Frequency Error[ppm]	Limit [ppm]
Normal (25C)	707.5	9.1	0.012811	2.5
Extreme (50C)	707.5	7.8	0.011049	2.5
Extreme (40C)	707.5	7.7	0.010923	2.5
Extreme (30C)	707.5	8.3	0.011699	2.5
Extreme (10C)	707.5	7.7	0.010930	2.5
Extreme (0C)	707.5	8.6	0.012116	2.5
Extreme (-10C)	707.5	8.1	0.011448	2.5
Extreme (-20C)	707.5	8.7	0.012347	2.5
Extreme (-30C)	707.5	8.2	0.011594	2.5

**Band 12 16QAM, (10MHz BANDWIDTH RB size 50 RB Offset 0)**

**Frequency error vs. Voltage**

Voltage [Vdc]	Frequency [MHz]	Frequency* Error[Hz]	Frequency Error[ppm]	Limit [ppm]
3.4	707.5	7.0	0.009856	2.5
3.85	707.5	8.7	0.012328	2.5
4.2	707.5	7.6	0.010797	2.5

**Frequency error vs. Temperature**

Temperature [° C]	Frequency [MHz]	Frequency* Error[Hz]	Frequency Error[ppm]	Limit [ppm]
Normal (25C)	707.5	6.5	0.009175	2.5
Extreme (50C)	707.5	5.5	0.007765	2.5
Extreme (40C)	707.5	6.4	0.009110	2.5
Extreme (30C)	707.5	-7.7	-0.010912	2.5
Extreme (10C)	707.5	-8.2	-0.011590	2.5
Extreme (0C)	707.5	2.9	0.004100	2.5
Extreme (-10C)	707.5	-5.2	-0.007292	2.5
Extreme (-20C)	707.5	-8.7	-0.012302	2.5
Extreme (-30C)	707.5	-10.2	-0.014350	2.5

**\*Note:** Frequency error measurements were made by using the build-in capability of the Wireless Communication Test Set.

## 10.6 LTE BAND 17

### Band 17 QPSK, (10MHz BANDWIDTH RB size 50 RB Offset 0)

#### Frequency error vs. Voltage

Voltage [Vdc]	Frequency [MHz]	Frequency* Error[Hz]	Frequency Error[ppm]	Limit [ppm]
3.4	710	9.8	0.013739	2.5
3.85	710	9.1	0.012872	2.5
4.2	710	8.6	0.012101	2.5

#### Frequency error vs. Temperature

Temperature [° C]	Frequency [MHz]	Frequency* Error[Hz]	Frequency Error[ppm]	Limit [ppm]
Normal (25C)	710	10.1	0.014181	2.5
Extreme (50C)	710	8.8	0.012405	2.5
Extreme (40C)	710	8.6	0.012082	2.5
Extreme (30C)	710	9.4	0.013252	2.5
Extreme (10C)	710	9.2	0.012930	2.5
Extreme (0C)	710	7.7	0.010820	2.5
Extreme (-10C)	710	8.8	0.012401	2.5
Extreme (-20C)	710	8.6	0.012048	2.5
Extreme (-30C)	710	7.9	0.011153	2.5

**Band 17 16QAM, (10MHz BANDWIDTH RB size 50 RB Offset 0)**

**Frequency error vs. Voltage**

Voltage [Vdc]	Frequency [MHz]	Frequency* Error[Hz]	Frequency Error[ppm]	Limit [ppm]
3.4	710	10.3	0.014546	2.5
3.85	710	8.7	0.012184	2.5
4.2	710	8.2	0.011539	2.5

**Frequency error vs. Temperature**

Temperature [° C]	Frequency [MHz]	Frequency* Error[Hz]	Frequency Error[ppm]	Limit [ppm]
Normal (25C)	710	8.9	0.012557	2.5
Extreme (50C)	710	9.0	0.012736	2.5
Extreme (40C)	710	8.5	0.011965	2.5
Extreme (30C)	710	8.8	0.012456	2.5
Extreme (10C)	710	7.7	0.010790	2.5
Extreme (0C)	710	8.4	0.011814	2.5
Extreme (-10C)	710	9.1	0.012840	2.5
Extreme (-20C)	710	8.6	0.012069	2.5
Extreme (-30C)	710	8.3	0.011697	2.5

**\*Note:** Frequency error measurements were made by using the build-in capability of the Wireless Communication Test Set.

## 11. Peak-to-Average Ratio

### 11.1 Description of the PAR Measurement

The peak-to-average ratio (PAR) of the transmission may not exceed 13 dB.

### 11.2 Measuring Instruments

See list of measuring instruments of this test report.

### 11.3 Test Procedures

1. The EUT was connected to Spectrum Analyzer and Base Station via power divider.
2. The RF output of EUT was connected to the spectrum analyzer by RF cable and attenuator. The path loss was compensated to the results for each measurement.
3. For LTE operating modes:
  - a. Set the CCDF (Complementary Cumulative Distribution Function) option in spectrum analyzer.
  - b. The highest RF powers were measured and recorded the maximum PAPR level associated with a probability of 0.1 %.

### 11.4 Test Setup

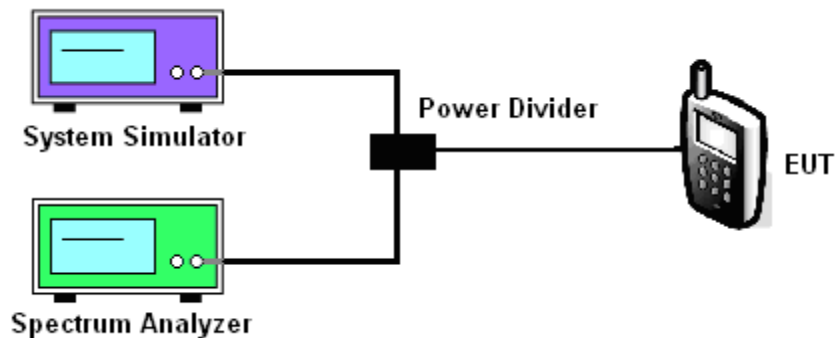

### MODES TESTED

- LTE Band 2/4/5/7/12/17
- 

Test data reference attachment.

----END OF REPORT----