

# **FCC RADIO TEST REPORT**

**FCC ID: 2AT9N-715003018**

**Sample :** BRP 107 Audio Cargo Box

**Trade Mark :** N/A

**Main Model :** 715003018

**Additional Model :** N/A

**Report No. :** 23051519ER-61

## **Prepared for**

Wet Sounds Inc.

2975 Louise Street Rosenberg Texas United States 77471

## **Prepared by**

Global United Technology Services Co. Ltd.

No. 123-128, Tower A, Jinyuan Business Building, No.2, Laodong Industrial Zone, Xixiang Road, Baoan District, Shenzhen, Guangdong, China 518102

### TEST RESULT CERTIFICATION

**Applicant**.....: Wet Sounds Inc.  
**Address**.....: 2975 Louise Street Rosenberg Texas United States 77471  
**Manufacturer** .....: UNITEIC COMPANY LIMITED  
**Address**.....: Gaolong Industrial, Huanzhuli Village, Changping Town Dongguan  
 Guangdong, China. Dongguan 523570 China (Peoples Republic Of)

**Product description**

**Product**.....: BRP 107 Audio Cargo Box  
**Trade Mark**.....: N/A  
**Model Name**.....: 715003018

**Test Methods** .....: FCC Rules and Regulations Part 15 Subpart C Section 15.249, ANSI C63.10: 2013

This device described above has been tested by Global United Technology Services Co. Ltd., and the test results show that the equipment under test (EUT) is in compliance with the FCC requirements. And it is applicable only to the tested sample identified in the report.

This report shall not be reproduced except in full, without the written approval, this document may be altered or revised by Global United Technology Services Co. Ltd., personnel only, and shall be noted in the revision of the document.

**Date of Test**

Date (s) of performance of tests..... : May 24, 2023 ~ May 31, 2023  
 Date of Issue ..... : Jul. 20, 2023  
 Test Result ..... : Pass

**Prepared By:**  **Date:** 2023-7-20  
 \_\_\_\_\_  
**Project Engineer**

**Check By:**  **Date:** 2023-7-20  
 \_\_\_\_\_  
**Reviewer**

<b>Table of Contents</b>	<b>Pages</b>
1 TEST SUMMARY	4
1.1 TEST PROCEDURES AND RESULTS	4
1.2 TEST FACILITY	5
1.3 MEASUREMENT UNCERTAINTY	6
1.4 ENVIRONMENTAL CONDITIONS	6
2 GENERAL INFORMATION	7
2.1 GENERAL DESCRIPTION OF EUT	7
2.2 CARRIER FREQUENCY OF CHANNELS	8
2.3 TEST MODE	8
2.4 TEST SETUP	9
2.5 EQUIPMENT USED IN TESTED SYSTEM	9
2.6 MEASUREMENT INSTRUMENTS LIST	10
3 CONDUCTED EMISSION	12
3.1 TEST LIMIT	12
3.2 TEST SETUP	12
3.3 TEST PROCEDURE	12
3.4 TEST RESULT	13
4 RADIATED EMISSION	14
4.1 TEST LIMIT	14
4.2 TEST SETUP	15
4.3 TEST PROCEDURE	16
4.4 TEST RESULT	16
5 BAND EDGE	28
5.1 TEST LIMIT	28
5.2 TEST PROCEDURE	28
5.3 TEST RESULT	28
6 20dB BANDWIDTH	31
6.1 TEST SETUP (BLOCK DIAGRAM OF CONFIGURATION)	31
6.2 MEASUREMENT EQUIPMENT USED	31
6.3 TEST PROCEDURE	31
6.4 TEST RESULT	31
7 ANTENNA REQUIREMENT	38
8 PHOTO OF TEST	39
8.1 RADIATED EMISSION	39
8.2 RF Conducted	40

## 1 TEST SUMMARY

### 1.1 TEST PROCEDURES AND RESULTS

Item	FCC Rules	Description Of Test	Result
1	FCC Part 15.207	Conducted Emission	N/A
2	FCC Part 15.209/15.249	Radiated Emission	Pass
3	FCC Part 15.249/15.205	Band Edge	Pass
4	FCC Part 15.215	20dB Bandwidth	Pass
5	FCC Part 15.203	Antenna Requirement	Pass

Note:

“N/A” denotes test is not applicable in this Test Report.

## 1.2 TEST FACILITY

Test Firm : Global United Technology Services Co. Ltd.  
Address : No. 123-128, Tower A, Jinyuan Business Building, No.2, Laodong Industrial Zone, Xixiang Road, Baoan District, Shenzhen, Guangdong, China 518102

The test facility is recognized, certified, or accredited by the following organizations:

- **FCC—Registration No.: 381383**

Designation Number: CN5029

Global United Technology Services Co., Ltd., Shenzhen EMC Laboratory has been registered and fully described in a report filed with the (FCC) Federal Communications Commission.

The acceptance letter from the FCC is maintained in files.

- **IC —Registration No.: 9079A**

CAB identifier: CN0091

The 3m Semi-anechoic chamber of Global United Technology Services Co., Ltd. has been registered by Certification and Engineering Bureau of Industry Canada for radio equipment testing

- **NVLAP (LAB CODE:600179-0)**

Global United Technology Services Co., Ltd., is accredited by the National Voluntary Laboratory Accreditation Program (NVLAP).

### 1.3 MEASUREMENT UNCERTAINTY

The reported uncertainty of measurement  $y \pm U$ , where expanded uncertainty  $U$  is based on a standard uncertainty multiplied by a coverage factor of  $k=2$ , providing a level of confidence of approximately 95 %.

#### A. Conducted Measurement:

Test Site	Method	Measurement Frequency Range	U, (dB)	NOTE
UNI	ANSI	9kHz ~ 150kHz	2.96	
		150kHz ~ 30MHz	2.44	

#### B. Radiated Measurement:

Test Site	Method	Measurement Frequency Range	U, (dB)	NOTE
UNI	ANSI	9kHz ~ 30MHz	2.50	
		30MHz ~ 1000MHz	4.80	
		Above 1000MHz	4.13	

#### C. RF Conducted Method:

Item	Measurement Uncertainty
Uncertainty of total RF power, conducted	$U_c = \pm 0.8$ dB
Uncertainty of RF power density, conducted	$U_c = \pm 2.6$ dB
Uncertainty of spurious emissions, conducted	$U_c = \pm 2$ %
Uncertainty of Occupied Channel Bandwidth	$U_c = \pm 2$ %

### 1.4 ENVIRONMENTAL CONDITIONS

During the measurement the environmental conditions were within the listed ranges:

Temperature:	15~35 °C
Relative Humidity:	30~60 %
Air Pressure:	950~1050 hPa

## 2 GENERAL INFORMATION

### 2.1 GENERAL DESCRIPTION OF EUT

Product:	BRP 107 Audio Cargo Box
Trade Mark:	N/A
Main Model:	715003018
Additional Model:	N/A
Model Difference:	N/A
FCC ID:	2AT9N-715003018
Operation Frequency:	2402MHz~2480MHz
Number of Channels:	79CH
Field Strength of Fundamental:	98.61dBuV/m(Peak)@3m
Modulation Type:	GFSK, $\pi/4$ DQPSK, 8DPSK
Antenna Type:	PCB Antenna
Antenna Gain:	-0.347dBi
Battery:	N/A
Adapter:	N/A
Power Source:	DC 12V

## 2.2 CARRIER FREQUENCY OF CHANNELS

Channel List							
Channel	Frequency (MHz)	Channel	Frequency (MHz)	Channel	Frequency (MHz)	Channel	Frequency (MHz)
00	2402	21	2423	42	2444	63	2465
01	2403	22	2424	43	2445	64	2466
02	2404	23	2425	44	2446	65	2467
03	2405	24	2426	45	2447	66	2468
04	2406	25	2427	46	2448	67	2469
05	2407	26	2428	47	2449	68	2470
06	2408	27	2429	48	2450	69	2471
07	2409	28	2430	49	2451	70	2472
08	2410	29	2431	50	2452	71	2473
09	2411	30	2432	51	2453	72	2474
10	2412	31	2433	52	2454	73	2475
11	2413	32	2434	53	2455	74	2476
12	2414	33	2435	54	2456	75	2477
13	2415	34	2436	55	2457	76	2478
14	2416	35	2437	56	2458	77	2479
15	2417	36	2438	57	2459	78	2480
16	2418	37	2439	58	2460		
17	2419	38	2440	59	2461		
18	2420	39	2441	60	2462		
19	2421	40	2442	61	2463		
20	2422	41	2443	62	2464		

## 2.3 TEST MODE

The EUT was programmed to be in continuously transmitting mode.

Channel List		
Test Channel	EUT Channel	Test Frequency (MHz)
Low	CH00	2402
Middle	CH39	2441
High	CH78	2480



### 2.4 TEST SETUP

Operation of EUT during Radiation testing:

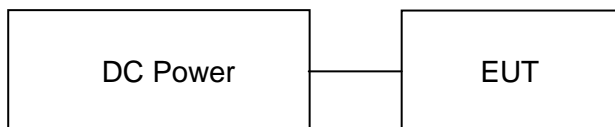

Operation of EUT during RF Conducted testing:

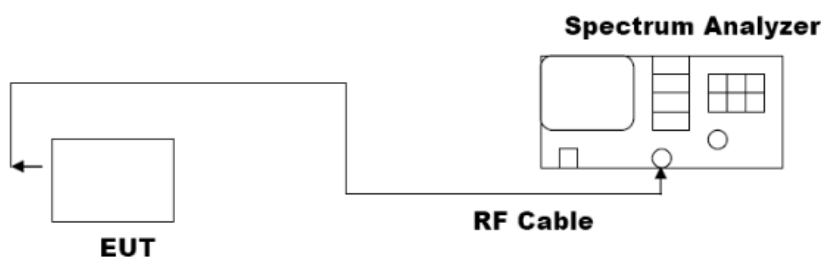

### 2.5 EQUIPMENT USED IN TESTED SYSTEM

Item	Equipment	Model/Type No.	Cable Length(m)	Note
1	BRP 107 Audio Cargo Box	715003018	--	EUT
2	DC Power Supply	--	--	AE

Note:

1. The support equipment was authorized by Declaration of Confirmation.
2. All the above equipment/cables were placed in worse case positions to maximize emission signals during emission test.

## 2.6 MEASUREMENT INSTRUMENTS LIST

Radiated Emission:						
Item	Test Equipment	Manufacturer	Model No.	Inventory No.	Cal.Date (mm-dd-yy)	Cal.Due date (mm-dd-yy)
1	3m Semi- Anechoic Chamber	ZhongYu Electron	9.2(L)*6.2(W)* 6.4(H)	GTS250	June 23, 2021	June 22, 2024
2	Control Room	ZhongYu Electron	6.2(L)*2.5(W)* 2.4(H)	GTS251	N/A	N/A
3	EMI Test Receiver	Rohde & Schwarz	ESU26	GTS203	April 14, 2023	April 13, 2024
4	BiConiLog Antenna	SCHWARZBECK MESS-ELEKTRONIK	VULB9168	GTS640	March 19, 2023	March 18, 2025
5	Double -ridged waveguide horn	SCHWARZBECK MESS-ELEKTRONIK	BBHA 9120 D	GTS208	April 17, 2023	April 16, 2025
6	EMI Test Software	AUDIX	E3	N/A	N/A	N/A
7	Coaxial Cable	GTS	N/A	GTS213	April 21, 2023	April 20, 2024
8	Coaxial Cable	GTS	N/A	GTS211	April 21, 2023	April 20, 2024
9	Coaxial cable	GTS	N/A	GTS210	April 21, 2023	April 20, 2024
10	Coaxial Cable	GTS	N/A	GTS212	April 21, 2023	April 20, 2024
11	Wideband Radio Communication Tester	Rohde & Schwarz	CMW500	GTS575	April 14, 2023	April 13, 2024
12	Loop Antenna	ZHINAN	ZN30900A	GTS534	Nov. 29, 2022	Nov. 28, 2023
13	Broadband Preampfier	SCHWARZBECK	BBV9718	GTS535	April 14, 2023	April 13, 2024
14	Amplifier(1GHz-26.5GHz)	HP	8449B	GTS601	April 14, 2023	April 13, 2024
15	Horn Antenna (18-26.5GHz)	/	UG-598A/U	GTS664	Oct. 30, 2022	Oct. 29, 2023
16	Horn Antenna (26.5-40GHz)	A.H Systems	SAS-573	GTS665	Oct. 30, 2022	Oct. 29, 2023
17	FSV-Signal Analyzer (10Hz-40GHz)	Keysight	FSV-40-N	GTS666	March 13, 2023	March 12, 2024
18	Amplifier	/	LNA-1000-30S	GTS650	April 14, 2023	April 13, 2024
19	CDNE M2+M3-16A	HCT	30MHz-300MHz	GTS668	Dec. 20, 2022	Dec.19, 2023
20	Thermo meter	JINCHUANG	GSP-8A	GTS643	April 19, 2023	April 18, 2024

<b>RF Conducted Test:</b>						
<b>Item</b>	<b>Test Equipment</b>	<b>Manufacturer</b>	<b>Model No.</b>	<b>Serial No.</b>	<b>Cal.Date (mm-dd-yy)</b>	<b>Cal.Due date (mm-dd-yy)</b>
1	MXA Signal Analyzer	Agilent	N9020A	GTS566	April 14, 2023	April 13, 2024
2	EMI Test Receiver	R&S	ESCI 7	GTS552	April 14, 2023	April 13, 2024
3	PSA Series Spectrum Analyzer	Agilent	E4440A	GTS536	April 14, 2023	April 13, 2024
4	MXG vector Signal Generator	Agilent	N5182A	GTS567	April 14, 2023	April 13, 2024
5	ESG Analog Signal Generator	Agilent	E4428C	GTS568	April 14, 2023	April 13, 2024
6	USB RF Power Sensor	DARE	RPR3006W	GTS569	April 14, 2023	April 13, 2024
7	RF Switch Box	Shongyi	RFSW3003328	GTS571	April 14, 2023	April 13, 2024
8	Programmable Constant Temp & Humi Test Chamber	WEWON	WHTH-150L-40-880	GTS572	April 14, 2023	April 13, 2024
9	Thermo meter	JINCHUANG	GSP-8A	GTS641	April 19, 2023	April 18, 2024

### 3 CONDUCTED EMISSION

#### 3.1 TEST LIMIT

For unintentional device, according to § 15.207(a) Line Conducted Emission Limits is as following

Frequency (MHz)	Maximum RF Line Voltage (dB V)			
	CLASS A		CLASS B	
	Q.P.	Ave.	Q.P.	Ave.
0.15~0.50	79	66	66~56*	56~46*
0.50~5.00	73	60	56	46
5.00~30.0	73	60	60	50

\* Decreasing linearly with the logarithm of the frequency.

For intentional device, according to §15.207(a) Line Conducted Emission Limit is same as above table.

#### 3.2 TEST SETUP

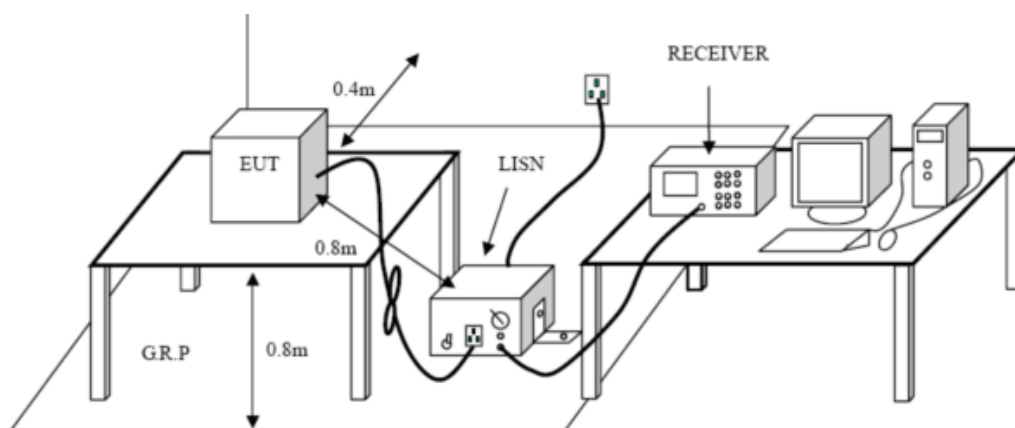

#### 3.3 TEST PROCEDURE

1. The equipment was set up as per the test configuration to simulate typical actual usage per the user's manual. The EUT is placed on a wooden table with a height of 0.8 meters is used and is placed on the ground plane as per ANSI C63.10.
2. Support equipment, if needed, was placed as per ANSI C63.10.
3. All I/O cables were positioned to simulate typical actual usage as per ANSI C63.10.
4. If a EUT received DC power from the USB Port of Notebook PC, the PC's adapter received AC120V/60Hz power through a Line Impedance Stabilization Network (LISN) which supplied power source and was grounded to the ground plane.
5. All support equipments received AC power from a second LISN, if any.
6. The EUT test program was started. Emissions were measured on each current carrying line of the EUT using a spectrum Analyzer / Receiver connected to the LISN powering the EUT. The LISN has two monitoring points: Line 1 (Hot Side) and Line 2 (Neutral Side). Two scans were taken: one with Line 1 connected to Analyzer / Receiver and Line 2 connected to a 50 ohm load; the second scan had Line 1 connected to a 50 ohm load and Line 2 connected to the Analyzer / Receiver.
7. Analyzer / Receiver scanned from 150 kHz to 30MHz for emissions in each of the test modes.

### 3.4 TEST RESULT

N/A

Remark:

The EUT is powered by battery

## 4 RADIATED EMISSION

### 4.1 TEST LIMIT

For unintentional device, according to § 15.209(a), except for Class B digital devices, the field strength of radiated emissions from unintentional radiators at a distance of 3 meters shall not exceed the following values:

Frequency	Field strength (microvolt/meter)	Limit (dBuV/m )	Remark	Measurement distance (m)
0.009MHz-0.490MHz	2400/F (kHz)	-	Quasi-peak	300
0.490MHz-1.705MHz	24000/F (kHz)	-	Quasi-peak	30
1.705MHz-30MHz	30	-	Quasi-peak	30
30MHz-88MHz	100	40.0	Quasi-peak	3
88MHz-216MHz	150	43.5	Quasi-peak	3
216MHz-960MHz	200	46.0	Quasi-peak	3
960MHz-1GHz	500	54.0	Quasi-peak	3
Above 1GHz	500	54.0	Average	3
		74.0	Peak	3

For intentional device, according to § 15.209(a), the general requirement of field strength of radiated emissions from intentional radiators at a distance of 3 meters shall not exceed the above table.

Limit: (Field strength of the fundamental signal)

Frequency	Limit (dBuV/m @3m)	Remark
2400MHz-2483.5MHz	94.0	Average Value
	114.0	Peak Value

### 4.2 TEST SETUP

#### 1. Radiated Emission Test-Up Frequency Below 30MHz

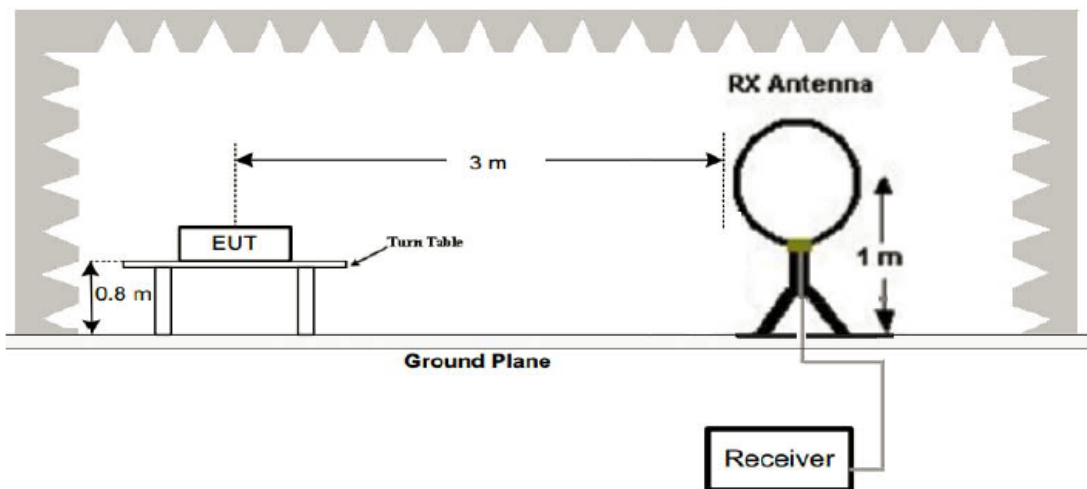

#### 2. Radiated Emission Test-Up Frequency 30MHz~1GHz

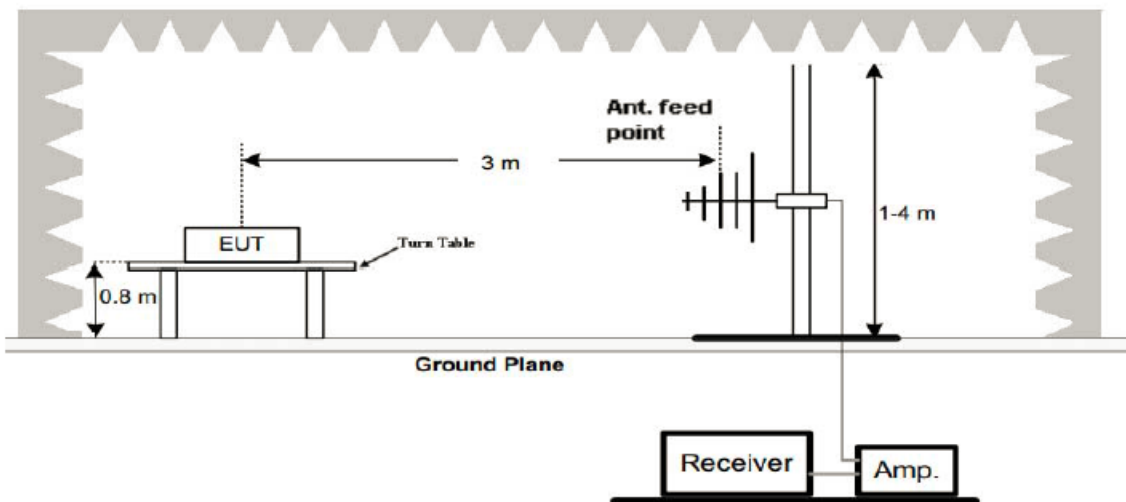

#### 3. Radiated Emission Test-Up Frequency Above 1GHz

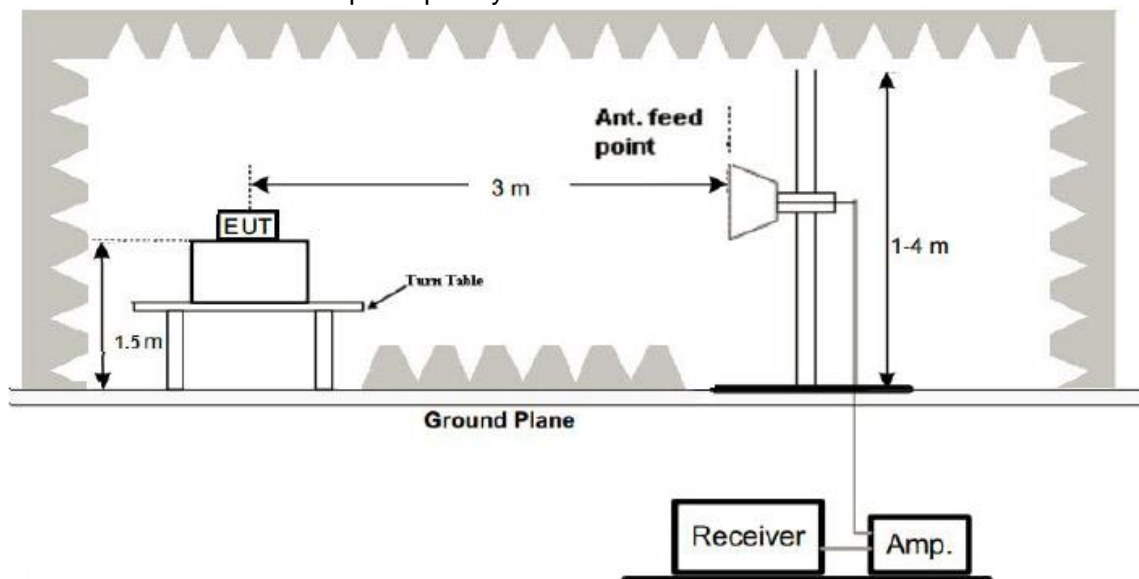

### 4.3 TEST PROCEDURE

1. Below 1GHz measurement the EUT is placed on turntable which is 0.8m above ground plane.  
And above 1GHz measurement EUT was placed on low permittivity and low tangent turn table which is 1.5m above ground plane.
2. The turntable shall be rotated for 360 degrees to determine the position of maximum emission level.
3. EUT is set 3m away from the receiving antenna, which is varied from 1m to 4m to find out the highest emissions.
4. Maximum procedure was performed on the six highest emissions to ensure EUT compliance.
5. And also, each emission was to be maximized by changing the polarization of receiving antenna both horizontal and vertical.
6. Repeat above procedures until the measurements for all frequencies are complete.
7. The test frequency range from 9kHz to 25GHz per FCC PART 15.33(a).

Note:

For battery operated equipment, the equipment tests shall be performed using a new battery.

### 4.4 TEST RESULT

PASS

Remark:

1. All modes were test at Low, Middle, and High channel, only the worst result of 8DPSK Low Channel was reported for below 1GHz test.
2. By preliminary testing and verifying three axis (X, Y and Z) position of EUT transmitted status, it was found that "X axis" position was the worst, and test data recorded in this report.
3. Radiated emission test from 9kHz to 10th harmonic of fundamental was verified, and no emission found except system noise floor in 9kHz to 30MHz and not recorded in this report.



Below 1GHz Test Results:

Temperature:	24°C	Relative Humidity:	48%
Test Date:	May 26, 2023	Pressure:	1010hPa
Test Voltage:	DC 12V	Phase:	Horizontal
Test Mode:	Transmitting mode of 8DPSK 2402MHz		



No.	Frequency (MHz)	Reading (dBuV)	Correction factor(dB/m)	Result (dBuV/m)	Limit (dBuV/m)	Margin (dB)	Degree (deg.)	Height (cm)	Remark
1*	30.5304	40.00	-7.50	32.50	40.00	-7.50	107	100	peak
2	81.4970	52.10	-20.79	31.31	40.00	-8.69	192	100	peak
3	148.9625	45.68	-16.81	28.87	43.50	-14.63	135	100	peak
4	201.3930	44.52	-16.47	28.05	43.50	-15.45	108	100	peak
5	531.9633	35.34	-12.68	22.66	46.00	-23.34	261	100	peak
6	836.2441	38.25	-6.28	31.97	46.00	-14.03	156	100	peak

Remark: Result = Reading Level + Factor, Margin = Result– Limit  
 Factor = Ant. Factor + Cable Loss – Pre-amplifier

Temperature:	24°C	Relative Humidity:	48%
Test Date:	May 26, 2023	Pressure:	1010hPa
Test Voltage:	DC 12V	Phase:	Vertical
Test Mode:	Transmitting mode of 8DPSK 2402MHz		



No.	Frequency (MHz)	Reading (dBuV)	Correction factor(dB/m)	Result (dBuV/m)	Limit (dBuV/m)	Margin (dB)	Degree (deg.)	Height (cm)	Remark
1*	33.0950	38.83	-9.43	29.40	40.00	-10.60	113	100	peak
2	76.2442	48.11	-20.74	27.37	40.00	-12.63	129	100	peak
3	178.1322	39.89	-17.56	22.33	43.50	-21.17	174	100	peak
4	198.5880	39.82	-16.58	23.24	43.50	-20.26	186	100	peak
5	459.1143	38.45	-11.64	26.81	46.00	-19.19	304	100	peak
6	601.4265	36.53	-9.00	27.53	46.00	-18.47	245	100	peak

Remark: Result = Reading Level + Factor, Margin = Result – Limit  
 Factor = Ant. Factor + Cable Loss – Pre-amplifier

Remark:

1. Measuring frequencies from 9 kHz to the 1 GHz, Radiated emission test from 9kHz to 30MHz was verified, and no any emission was found except system noise floor.
2. \* denotes emission frequency which appearing within the Restricted Bands specified in provision of 15.205, then the general radiated emission limits in 15.209 apply.
3. The IF bandwidth of EMI Test Receiver between 30MHz to 1GHz was 120kHz, 1 MHz for measuring above 1 GHz, below 30MHz was 10kHz.

## Above 1 GHz Test Results:

GFSK Modulation:  
CH00 (2402MHz)

## Horizontal:

Frequency (MHz)	Reading Result (dB $\mu$ V)	Factor (dB)	Emission Level (dB $\mu$ V/m)	Limits (dB $\mu$ V/m)	Margin (dB)	Detector Type
2402	95.18	-5.84	89.34	114	-24.66	PK
2402	68.43	-5.84	62.59	94	-31.41	AV
4804	46.34	-3.64	42.7	74	-31.3	PK
4804	33.66	-3.64	30.02	54	-23.98	AV
7206	41.78	-0.95	40.83	74	-33.17	PK
7206	29.92	-0.95	28.97	54	-25.03	AV

Remark: Factor = Antenna Factor + Cable Loss – Pre-amplifier. Margin = Emission Level – Limit

## Vertical:

Frequency (MHz)	Reading Result (dB $\mu$ V)	Factor (dB)	Emission Level (dB $\mu$ V/m)	Limits (dB $\mu$ V/m)	Margin (dB)	Detector Type
2402	90.14	-5.84	84.3	114	-29.7	PK
2402	66.21	-5.84	60.37	94	-33.63	AV
4804	45.47	-3.64	41.83	74	-32.17	PK
4804	32.45	-3.64	28.81	54	-25.19	AV
7206	41.38	-0.95	40.43	74	-33.57	PK
7206	30.66	-0.95	29.71	54	-24.29	AV

Remark: Factor = Antenna Factor + Cable Loss – Pre-amplifier. Margin = Emission Level – Limit

## CH39 (2441MHz)

Horizontal:

Frequency	Reading Result	Factor	Emission Level	Limits	Margin	Detector Type
(MHz)	(dB $\mu$ V)	(dB)	(dB $\mu$ V/m)	(dB $\mu$ V/m)	(dB)	
2441	98.53	-5.71	92.82	114	-21.18	PK
2441	67.22	-5.71	61.51	94	-32.49	AV
4882	44.46	-3.51	40.95	74	-33.05	PK
4882	33.55	-3.51	30.04	54	-23.96	AV
7323	41.63	-0.82	40.81	74	-33.19	PK
7323	29.86	-0.82	29.04	54	-24.96	AV

Remark: Factor = Antenna Factor + Cable Loss – Pre-amplifier. Margin = Emission Level – Limit

Vertical:

Frequency	Reading Result	Factor	Emission Level	Limits	Margin	Detector Type
(MHz)	(dB $\mu$ V)	(dB)	(dB $\mu$ V/m)	(dB $\mu$ V/m)	(dB)	
2441	90.58	-5.71	84.87	114	-29.13	PK
2441	67.45	-5.71	61.74	94	-32.26	AV
4882	44.39	-3.51	40.88	74	-33.12	PK
4882	33.53	-3.51	30.02	54	-23.98	AV
7323	41.45	-0.82	40.63	74	-33.37	PK
7323	31.32	-0.82	30.5	54	-23.5	AV

Remark: Factor = Antenna Factor + Cable Loss – Pre-amplifier. Margin = Emission Level – Limit

## CH78 (2480MHz)

## Horizontal:

Frequency (MHz)	Reading Result (dB $\mu$ V)	Factor (dB)	Emission Level (dB $\mu$ V/m)	Limits (dB $\mu$ V/m)	Margin (dB)	Detector Type
2480	95.22	-5.65	89.57	114	-24.43	PK
2480	67.31	-5.65	61.66	94	-32.34	AV
4960	45.14	-3.43	41.71	74	-32.29	PK
4960	33.38	-3.43	29.95	54	-24.05	AV
7440	41.25	-0.75	40.5	74	-33.5	PK
7440	30.33	-0.75	29.58	54	-24.42	AV

Remark: Factor = Antenna Factor + Cable Loss – Pre-amplifier. Margin = Emission Level – Limit

## Vertical:

Frequency (MHz)	Reading Result (dB $\mu$ V)	Factor (dB)	Emission Level (dB $\mu$ V/m)	Limits (dB $\mu$ V/m)	Margin (dB)	Detector Type
2480	80.23	-5.65	74.58	114	-39.42	PK
2480	67.37	-5.65	61.72	94	-32.28	AV
4960	45.25	-3.43	41.82	74	-32.18	PK
4960	32.56	-3.43	29.13	54	-24.87	AV
7440	42.61	-0.75	41.86	74	-32.14	PK
7440	29.74	-0.75	28.99	54	-25.01	AV

Remark: Factor = Antenna Factor + Cable Loss – Pre-amplifier. Margin = Emission Level – Limit

$\pi/4$  DQPSK Modulation:  
CH00 (2402MHz)

Horizontal:

Frequency (MHz)	Reading Result (dB $\mu$ V)	Factor (dB)	Emission Level (dB $\mu$ V/m)	Limits (dB $\mu$ V/m)	Margin (dB)	Detector Type
2402	95.28	-5.84	89.44	114	-24.56	PK
2402	67.33	-5.84	61.49	94	-32.51	AV
4804	45.19	-3.64	41.55	74	-32.45	PK
4804	33.37	-3.64	29.73	54	-24.27	AV
7206	41.76	-0.95	40.81	74	-33.19	PK
7206	30.03	-0.95	29.08	54	-24.92	AV

Remark: Factor = Antenna Factor + Cable Loss – Pre-amplifier. Margin = Emission Level – Limit

Vertical:

Frequency (MHz)	Reading Result (dB $\mu$ V)	Factor (dB)	Emission Level (dB $\mu$ V/m)	Limits (dB $\mu$ V/m)	Margin (dB)	Detector Type
2402	80.27	-5.84	74.43	114	-39.57	PK
2402	67.34	-5.84	61.5	94	-32.5	AV
4804	44.45	-3.64	40.81	74	-33.19	PK
4804	33.23	-3.64	29.59	54	-24.41	AV
7206	41.32	-0.95	40.37	74	-33.63	PK
7206	30.37	-0.95	29.42	54	-24.58	AV

Remark: Factor = Antenna Factor + Cable Loss – Pre-amplifier. Margin = Emission Level – Limit

## CH39 (2441MHz)

Horizontal:

Frequency	Reading Result	Factor	Emission Level	Limits	Margin	Detector Type
(MHz)	(dB $\mu$ V)	(dB)	(dB $\mu$ V/m)	(dB $\mu$ V/m)	(dB)	
2441	95.03	-5.71	89.32	114	-24.68	PK
2441	67.35	-5.71	61.64	94	-32.36	AV
4882	45.81	-3.51	42.3	74	-31.7	PK
4882	33.43	-3.51	29.92	54	-24.08	AV
7323	42.77	-0.82	41.95	74	-32.05	PK
7323	30.45	-0.82	29.63	54	-24.37	AV

Remark: Factor = Antenna Factor + Cable Loss – Pre-amplifier. Margin = Emission Level – Limit

Vertical:

Frequency	Reading Result	Factor	Emission Level	Limits	Margin	Detector Type
(MHz)	(dB $\mu$ V)	(dB)	(dB $\mu$ V/m)	(dB $\mu$ V/m)	(dB)	
2441	80.04	-5.71	74.33	114	-39.67	PK
2441	67.55	-5.71	61.84	94	-32.16	AV
4882	45.87	-3.51	42.36	74	-31.64	PK
4882	32.45	-3.51	28.94	54	-25.06	AV
7323	42.62	-0.82	41.8	74	-32.2	PK
7323	31.24	-0.82	30.42	54	-23.58	AV

Remark: Factor = Antenna Factor + Cable Loss – Pre-amplifier. Margin = Emission Level – Limit

## CH78 (2480MHz)

## Horizontal:

Frequency	Reading Result	Factor	Emission Level	Limits	Margin	Detector Type
(MHz)	(dB $\mu$ V)	(dB)	(dB $\mu$ V/m)	(dB $\mu$ V/m)	(dB)	
2480	95.25	-5.65	89.6	114	-24.4	PK
2480	67.62	-5.65	61.97	94	-32.03	AV
4960	45.73	-3.43	42.3	74	-31.7	PK
4960	33.44	-3.43	30.01	54	-23.99	AV
7440	42.37	-0.75	41.62	74	-32.38	PK
7440	31.16	-0.75	30.41	54	-23.59	AV

Remark: Factor = Antenna Factor + Cable Loss – Pre-amplifier. Margin = Emission Level – Limit

## Vertical:

Frequency	Reading Result	Factor	Emission Level	Limits	Margin	Detector Type
(MHz)	(dB $\mu$ V)	(dB)	(dB $\mu$ V/m)	(dB $\mu$ V/m)	(dB)	
2480	80.27	-5.65	74.62	114	-39.38	PK
2480	67.43	-5.65	61.78	94	-32.22	AV
4960	45.94	-3.43	42.51	74	-31.49	PK
4960	32.58	-3.43	29.15	54	-24.85	AV
7440	41.76	-0.75	41.01	74	-32.99	PK
7440	30.32	-0.75	29.57	54	-24.43	AV

Remark: Factor = Antenna Factor + Cable Loss – Pre-amplifier. Margin = Emission Level – Limit



8DPSK Modulation:  
CH00 (2402MHz)

Horizontal:

Frequency	Reading Result	Factor	Emission Level	Limits	Margin	Detector Type
(MHz)	(dB $\mu$ V)	(dB)	(dB $\mu$ V/m)	(dB $\mu$ V/m)	(dB)	
2402	104.45	-5.84	98.61	114	-15.39	PK
2402	67.25	-5.84	61.41	94	-32.59	AV
4804	44.98	-3.64	41.34	74	-32.66	PK
4804	33.12	-3.64	29.48	54	-24.52	AV
7206	41.77	-0.95	40.82	74	-33.18	PK
7206	31.55	-0.95	30.6	54	-23.4	AV

Remark: Factor = Antenna Factor + Cable Loss – Pre-amplifier. Margin = Emission Level – Limit

Vertical:

Frequency	Reading Result	Factor	Emission Level	Limits	Margin	Detector Type
(MHz)	(dB $\mu$ V)	(dB)	(dB $\mu$ V/m)	(dB $\mu$ V/m)	(dB)	
2402	99.81	-5.84	93.97	114	-20.03	PK
2402	67.36	-5.84	61.52	94	-32.48	AV
4804	43.18	-3.64	39.54	74	-34.46	PK
4804	33.93	-3.64	30.29	54	-23.71	AV
7206	41.85	-0.95	40.9	74	-33.1	PK
7206	31.47	-0.95	30.52	54	-23.48	AV

Remark: Factor = Antenna Factor + Cable Loss – Pre-amplifier. Margin = Emission Level – Limit

## CH39 (2441MHz)

Horizontal:

Frequency	Reading Result	Factor	Emission Level	Limits	Margin	Detector Type
(MHz)	(dB $\mu$ V)	(dB)	(dB $\mu$ V/m)	(dB $\mu$ V/m)	(dB)	
2441	94.67	-5.71	88.96	114	-25.04	PK
2441	67.55	-5.71	61.84	94	-32.16	AV
4882	45.42	-3.51	41.91	74	-32.09	PK
4882	33.14	-3.51	29.63	54	-24.37	AV
7323	41.79	-0.82	40.97	74	-33.03	PK
7323	29.76	-0.82	28.94	54	-25.06	AV

Remark: Factor = Antenna Factor + Cable Loss – Pre-amplifier. Margin = Emission Level – Limit

Vertical:

Frequency	Reading Result	Factor	Emission Level	Limits	Margin	Detector Type
(MHz)	(dB $\mu$ V)	(dB)	(dB $\mu$ V/m)	(dB $\mu$ V/m)	(dB)	
2441	79.65	-5.71	73.94	114	-40.06	PK
2441	67.63	-5.71	61.92	94	-32.08	AV
4882	43.57	-3.51	40.06	74	-33.94	PK
4882	33.25	-3.51	29.74	54	-24.26	AV
7323	41.72	-0.82	40.9	74	-33.1	PK
7323	29.84	-0.82	29.02	54	-24.98	AV

Remark: Factor = Antenna Factor + Cable Loss – Pre-amplifier. Margin = Emission Level – Limit

## CH78 (2480MHz)

## Horizontal:

Frequency	Reading Result	Factor	Emission Level	Limits	Margin	Detector Type
(MHz)	(dB $\mu$ V)	(dB)	(dB $\mu$ V/m)	(dB $\mu$ V/m)	(dB)	
2480	95.35	-5.65	89.7	114	-24.3	PK
2480	67.39	-5.65	61.74	94	-32.26	AV
4960	44.35	-3.43	40.92	74	-33.08	PK
4960	33.13	-3.43	29.7	54	-24.3	AV
7440	39.84	-0.75	39.09	74	-34.91	PK
7440	29.77	-0.75	29.02	54	-24.98	AV

Remark: Factor = Antenna Factor + Cable Loss – Pre-amplifier. Margin = Emission Level – Limit

## Vertical:

Frequency	Reading Result	Factor	Emission Level	Limits	Margin	Detector Type
(MHz)	(dB $\mu$ V)	(dB)	(dB $\mu$ V/m)	(dB $\mu$ V/m)	(dB)	
2480	80.36	-5.65	74.71	114	-39.29	PK
2480	65.54	-5.65	59.89	94	-34.11	AV
4960	43.32	-3.43	39.89	74	-34.11	PK
4960	33.97	-3.43	30.54	54	-23.46	AV
7440	39.91	-0.75	39.16	74	-34.84	PK
7440	29.74	-0.75	28.99	54	-25.01	AV

Remark: Factor = Antenna Factor + Cable Loss – Pre-amplifier. Margin = Emission Level – Limit

## Remark:

1. Measuring frequencies from 1 GHz to the 25 GHz.
2. "F" denotes fundamental frequency; "H" denotes spurious frequency. "E" denotes band edge frequency.
3. \* denotes emission frequency which appearing within the Restricted Bands specified in provision of 15.205, then the general radiated emission limits in 15.209 apply.
4. Data of measurement within this frequency range shown "---" in the table above means the reading of emissions are attenuated more than 20dB below the permissible limits or the field strength is too small to be measured.
5. The IF bandwidth of EMI Test Receiver between 30MHz to 1GHz was 120kHz, 1 MHz for measuring above 1 GHz, below 30MHz was 10kHz. The resolution bandwidth of test receiver/spectrum analyzer is 1MHz and video bandwidth is 3MHz for peak measurement with peak detector at frequency above 1GHz. The resolution bandwidth of test receiver/spectrum analyzer is 1MHz and video bandwidth is 10Hz for Average measurement with peak detection at frequency above 1GHz.
6. When the test results of Peak Detected below the limits of Average Detected, the Average Detected is not need completed. For example: Top Channel at Fundamental 73.16dBuV/m(PK Value) <93.98(AV Limit), at harmonic 53.20 dBuV/m(PK Value) <54 dBuV/m(AV Limit), the Average Detected not need to completed.
7. For fundamental frequency, RBW>20dB Bandwidth, VBW>=3\*RBW, Peak detector for PK value, RMS detector for AV value.

## **5 BAND EDGE**

### **5.1 TEST LIMIT**

FCC PART 15.249(d) Emissions radiated outside of the specified frequency bands, except for harmonics, shall be attenuated by at least 50 dB below the level of the fundamental or to the general radiated emission limits in §15.209, whichever is the lesser attenuation.

### **5.2 TEST PROCEDURE**

The band edge compliance of RF radiated emission should be measured by following the guidance in ANSI C63.10 with respect to maximizing the emission by rotating the EUT, measuring the emission while the EUT is situated in three orthogonal planes (if appropriate), adjusting the measurement antenna height and polarization etc. Set RBW to 1MHz and VBW to 3MHz to measure the peak field strength and set RBW to 1MHz and VBW to 10Hz to measure the average radiated field strength. Peak detector is for both.

### **5.3 TEST RESULT**

PASS

Remark: All modes of were tested, only the worst result of 8DPSK was reported.

Operation Mode: TX CH00 (2402MHz)

Horizontal:

Frequency (MHz)	Reading Result (dB $\mu$ V)	Factor (dB)	Emission Level (dB $\mu$ V/m)	Limits (dB $\mu$ V/m)	Margin (dB)	Detector Type
2310	39.38	-5.81	33.57	74	-40.43	PK
2310	/	-5.81	/	54	/	AV
2390	39.05	-5.84	33.21	74	-40.79	PK
2390	/	-5.84	/	54	/	AV
2400	40.13	-5.84	34.29	74	-39.71	PK
2400	/	-5.84	/	54	/	AV

Remark: Factor = Antenna Factor + Cable Loss – Pre-amplifier.

Vertical:

Frequency (MHz)	Reading Result (dB $\mu$ V)	Factor (dB)	Emission Level (dB $\mu$ V/m)	Limits (dB $\mu$ V/m)	Margin (dB)	Detector Type
2310	40.24	-5.81	34.43	74	-39.57	PK
2310	/	-5.81	/	54	/	AV
2390	40.09	-5.84	34.25	74	-39.75	PK
2390	/	-5.84	/	54	/	AV
2400	41.36	-5.84	35.52	74	-38.48	PK
2400	/	-5.84	/	54	/	AV

Remark: Factor = Antenna Factor + Cable Loss – Pre-amplifier.

Operation Mode: TX CH78 (2480MHz)

Horizontal:

Frequency (MHz)	Reading Result (dB $\mu$ V)	Factor (dB)	Emission Level (dB $\mu$ V/m)	Limits (dB $\mu$ V/m)	Margin (dB)	Detector Type
2483.5	40.86	-5.65	35.21	74	-38.79	PK
2483.5	/	-5.65	/	54	/	AV
2500	40.15	-5.72	34.43	74	-39.57	PK
2500	/	-5.72	/	54	/	AV

Remark: Factor = Antenna Factor + Cable Loss – Pre-amplifier.

Vertical:

Frequency (MHz)	Reading Result (dB $\mu$ V)	Factor (dB)	Emission Level (dB $\mu$ V/m)	Limits (dB $\mu$ V/m)	Margin (dB)	Detector Type
2483.5	41.58	-5.65	35.93	74	-38.07	PK
2483.5	/	-5.65	/	54	/	AV
2500	41.23	-5.72	35.51	74	-38.49	PK
2500	/	-5.72	/	54	/	AV

Remark: Factor = Antenna Factor + Cable Loss – Pre-amplifier.

## 6 20dB BANDWIDTH

### 6.1 TEST SETUP (BLOCK DIAGRAM OF CONFIGURATION)

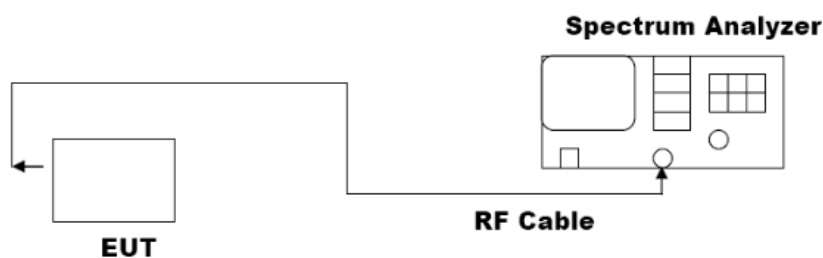

### 6.2 MEASUREMENT EQUIPMENT USED

Refer to Section 3.3.

### 6.3 TEST PROCEDURE

1. The RF output of EUT was connected to the spectrum analyzer by RF cable and attenuator. The path loss was compensated to the results for each measurement.
2. Set to the maximum power setting and enable the EUT transmit continuously.
3. Make the measurement with the spectrum analyzer's resolution bandwidth (RBW) = 30 kHz. Set the Video bandwidth (VBW) = 100 kHz. In order to make an accurate measurement.
4. For 20dB Bandwidth Measurement, the spectrum analyzer's resolution bandwidth (RBW) is set 1-5% of the emission bandwidth and set the Video bandwidth (VBW)  $\geq 3 * RBW$ .
5. Measure and record the results in the test report.

### 6.4 TEST RESULT

PASS

GFSK Modulation:

Channel	Frequency (MHz)	20dB Bandwidth (MHz)	Result
CH00	2402	0.971	PASS
CH39	2441	0.971	PASS
CH78	2480	0.976	PASS

CH00: 2402MHz

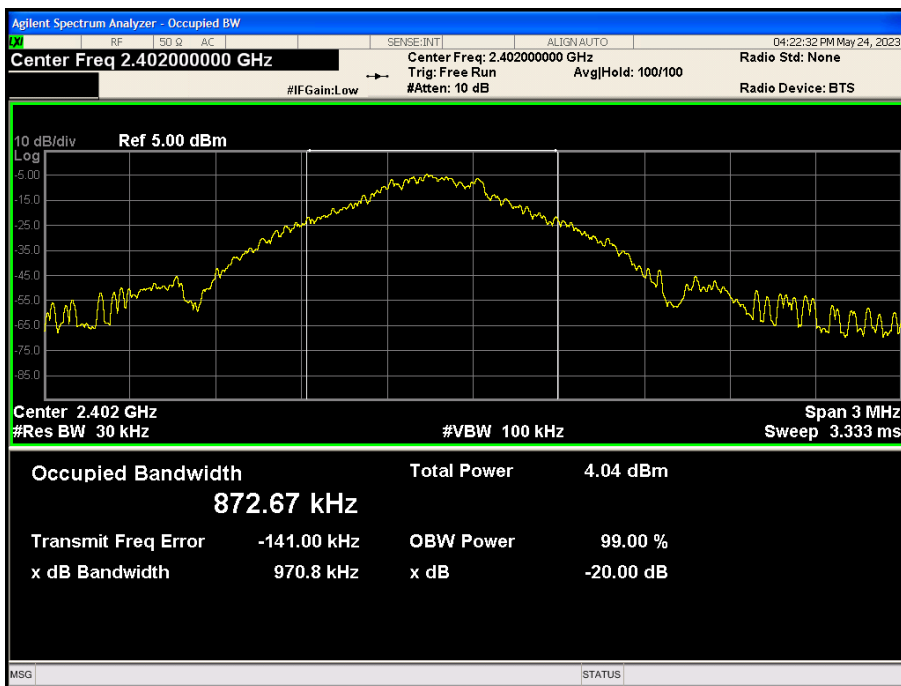



CH39: 2441MHz

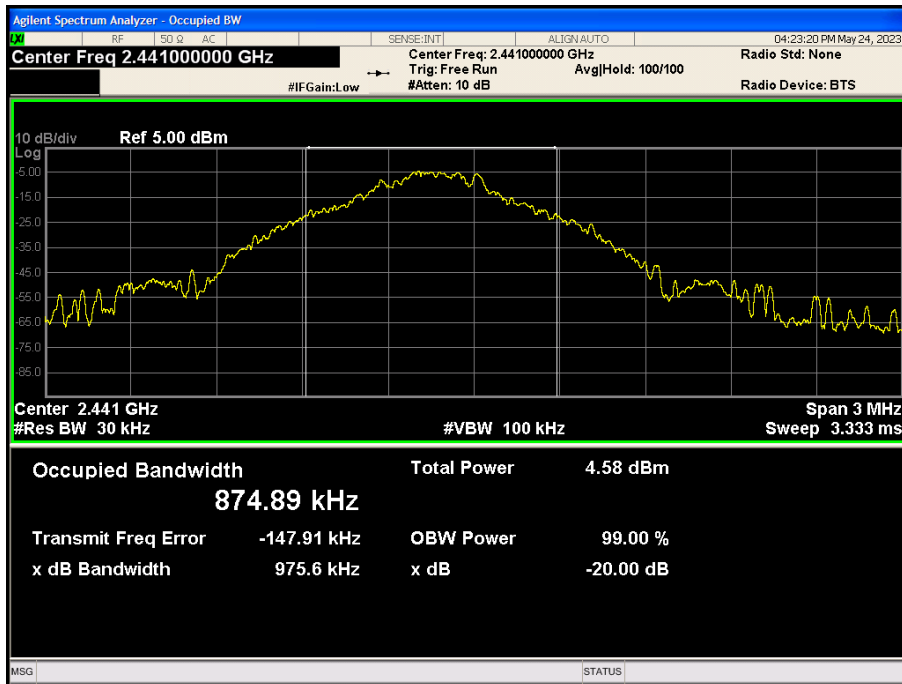

CH78: 2480MHz

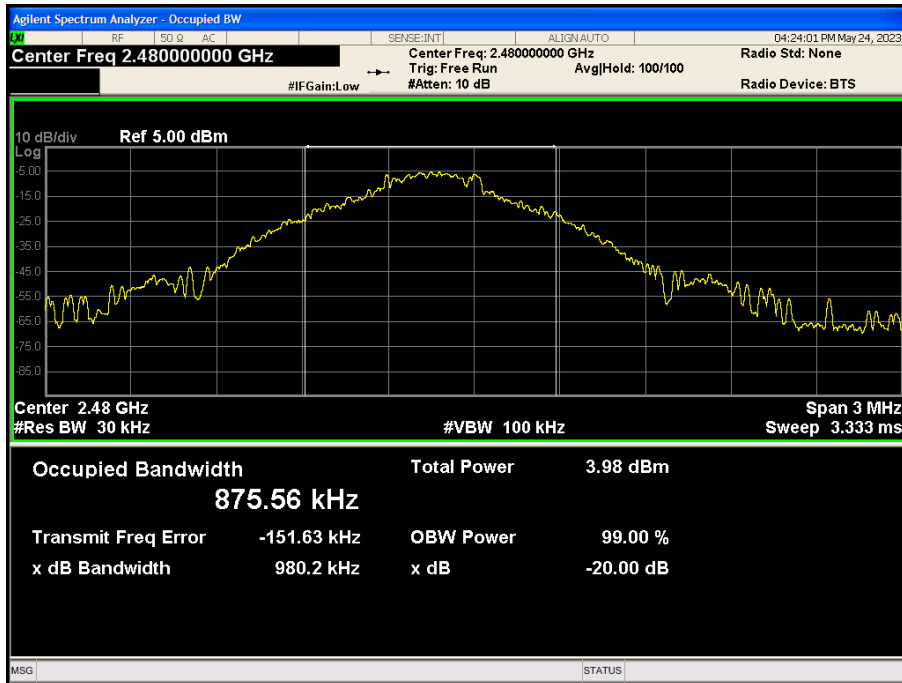

$\pi/4$  DQPSK Modulation:

Channel	Frequency (MHz)	20dB Bandwidth (MHz)	Result
CH00	2402	1.268	PASS
CH39	2441	1.300	PASS
CH78	2480	1.306	PASS

CH00: 2402MHz

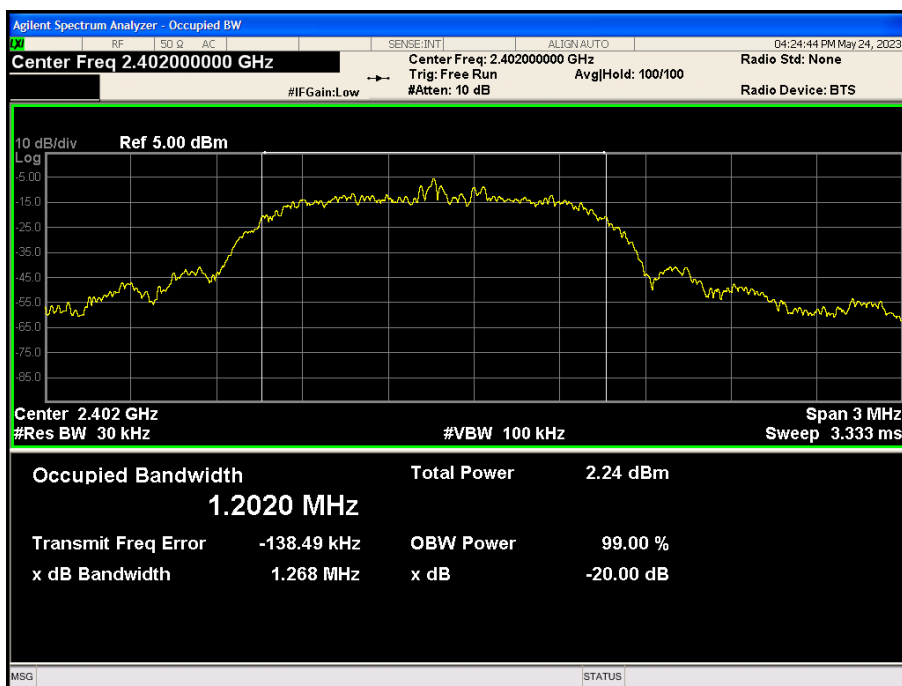

CH39: 2441MHz

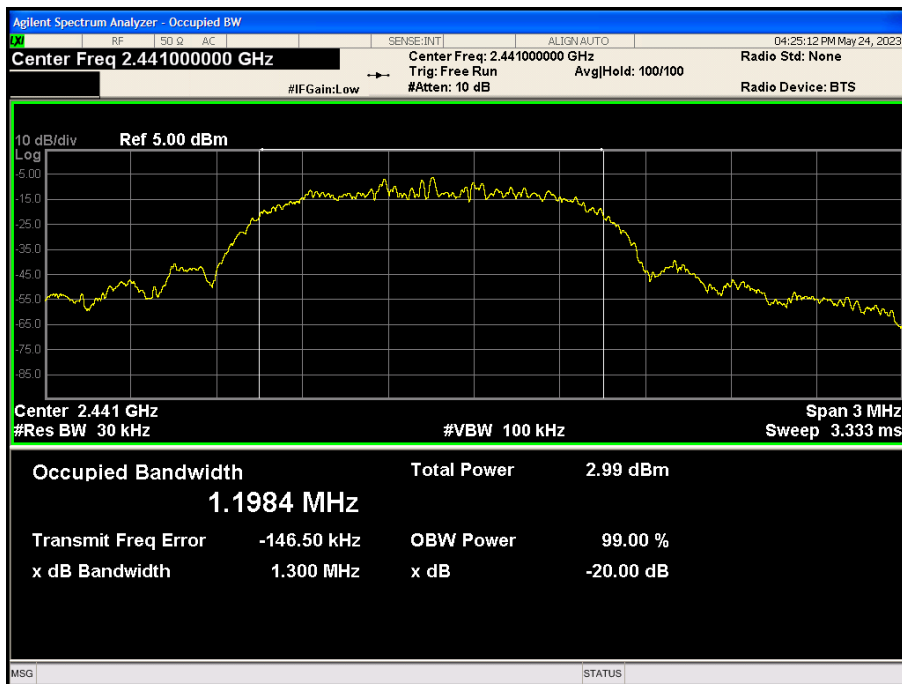

CH78: 2480MHz

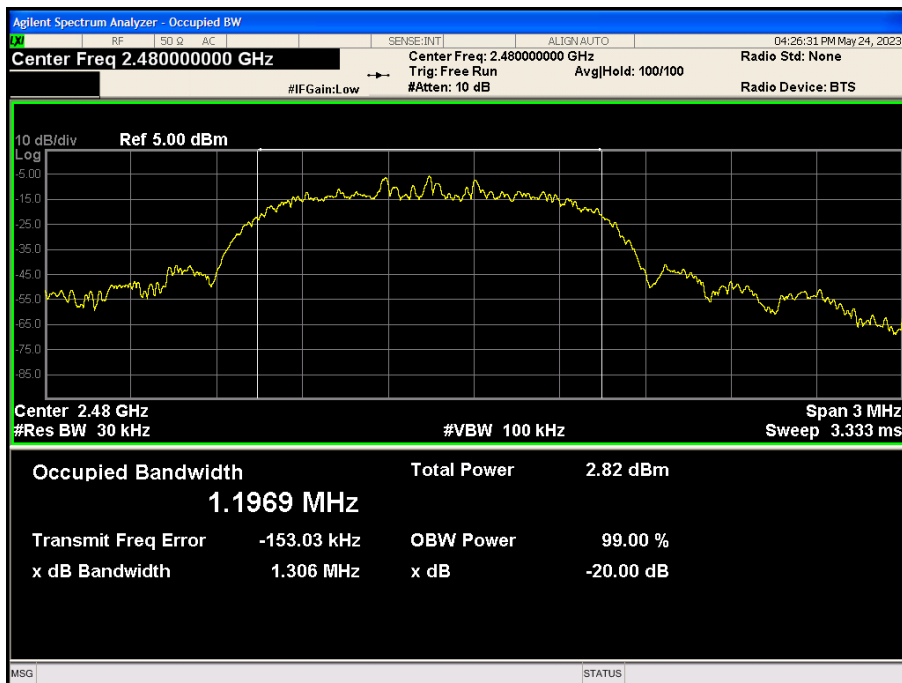

8DPSK Modulation:

Channel	Frequency (MHz)	20dB Bandwidth (MHz)	Result
CH00	2402	1.311	PASS
CH39	2441	1.300	PASS
CH78	2480	1.291	PASS

CH00: 2402MHz

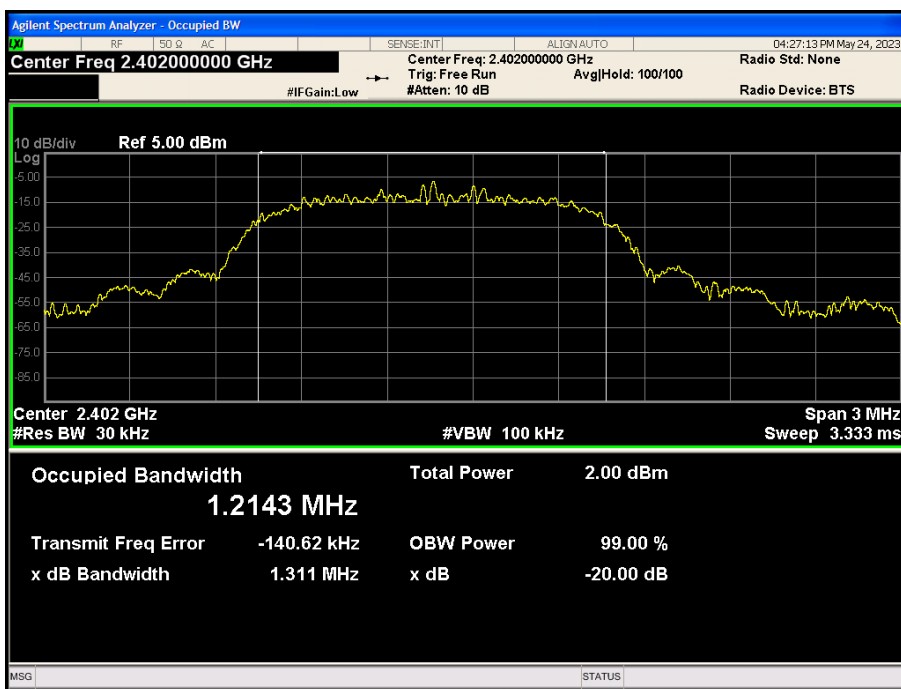

CH39: 2441MHz

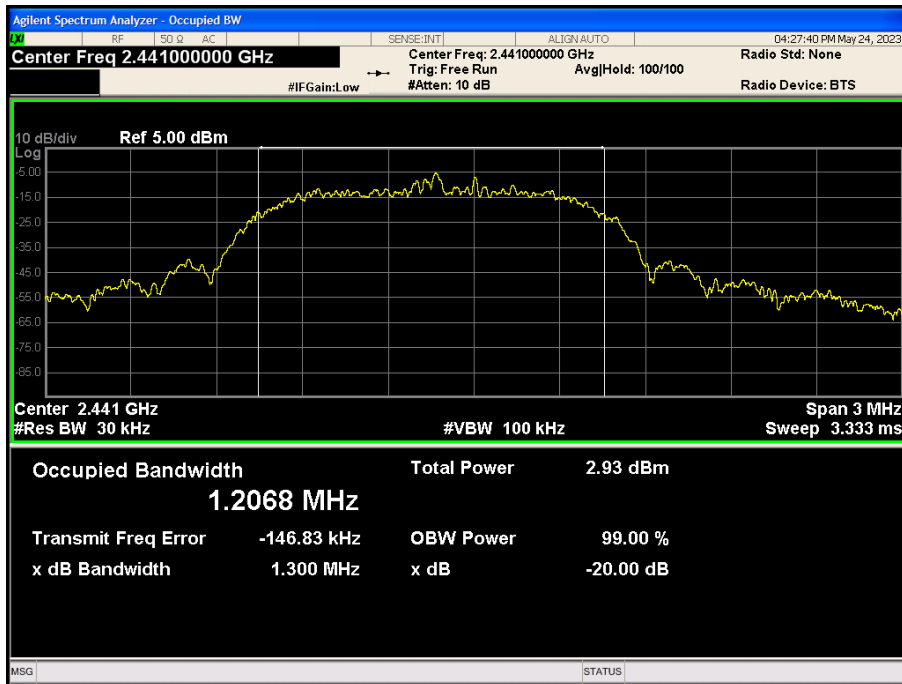

CH78: 2480MHz

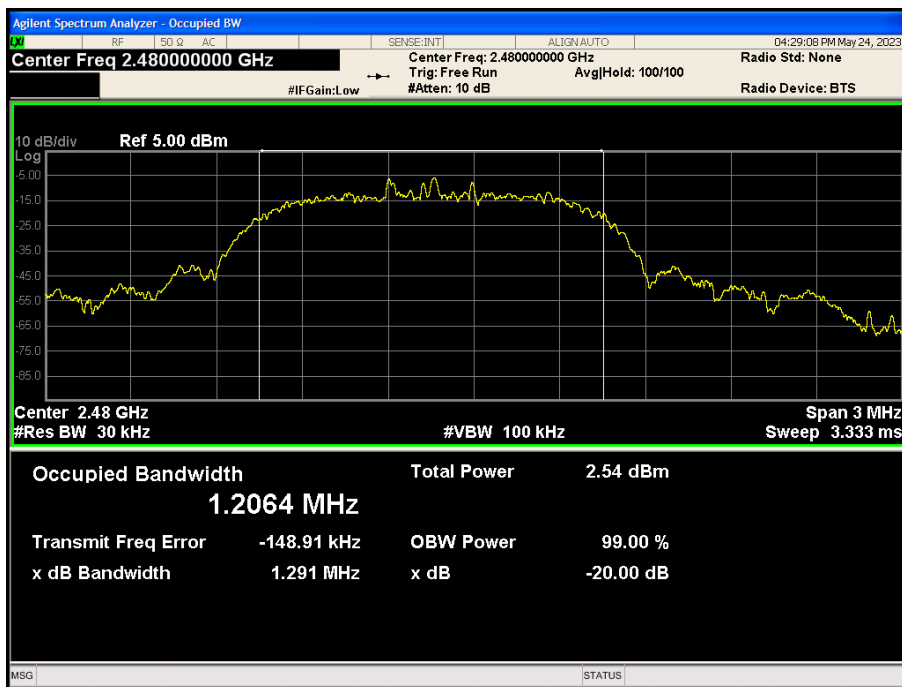

## 7 ANTENNA REQUIREMENT

Standard Applicable:

For intentional device, according to FCC 47 CFR Section 15.203, an intentional radiator shall be designed to ensure that no antenna other than that furnished by the responsible party shall be used with the device.

Antenna Connected Construction

The antenna used in this product is a PCB Antenna, The directional gains of antenna used for transmitting is -0.347dBi.

ANTENNA:

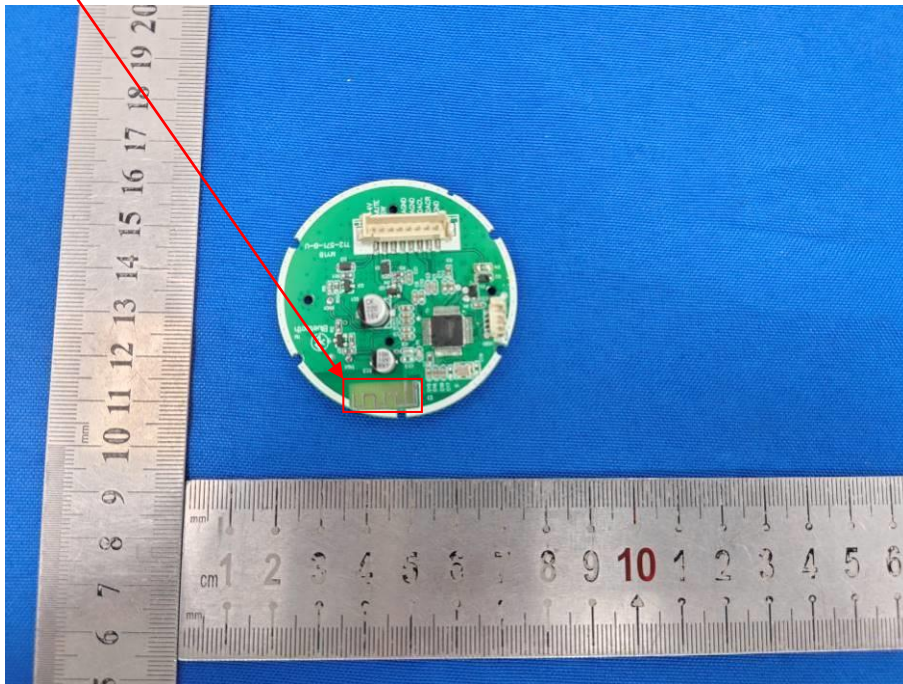

## 8 PHOTO OF TEST

### 8.1 RADIATED EMISSION

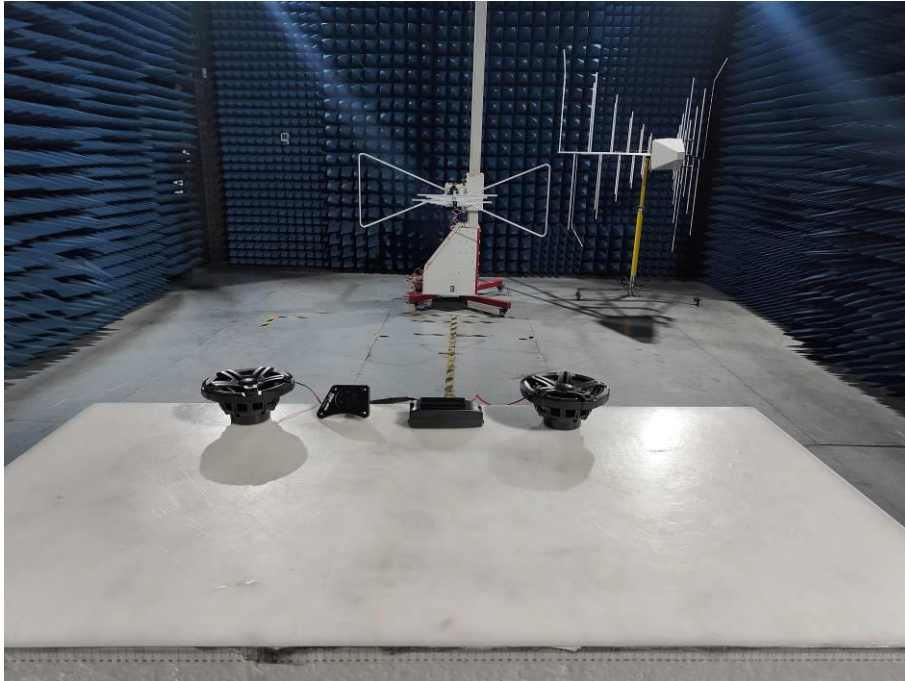

30MHz-1000MHz



Above 1GHz

## 8.2 RF Conducted

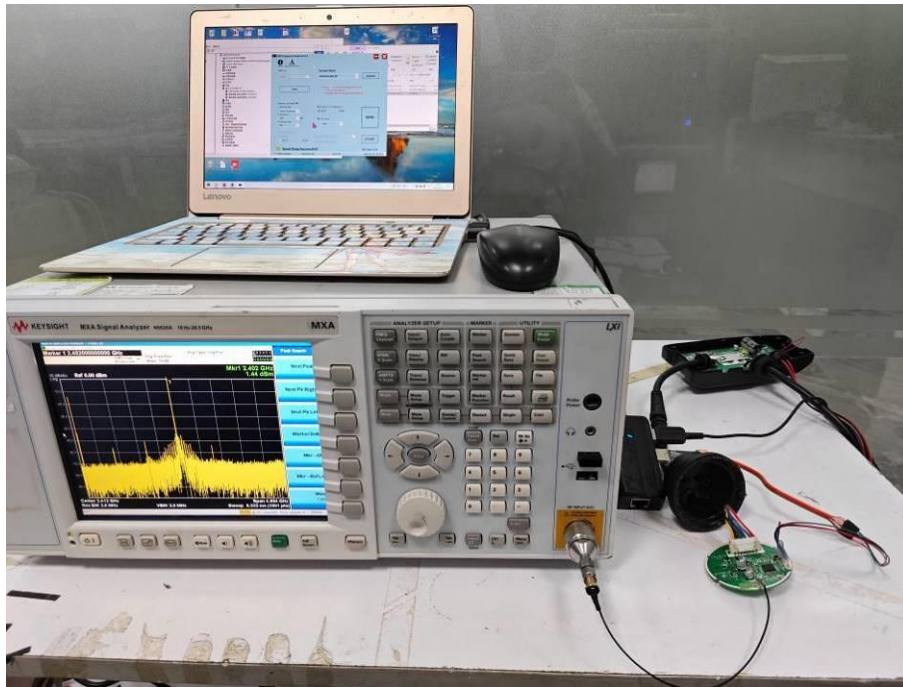

\*\*\*End of Report\*\*\*