ANTENNASPECIFICATION

Revision history

Version	Date	state
V1	2023-09-08	first edition

ANTENNASPECIFICATION

1. 项目信息 Project Information

1.1. 外观尺寸 Appearance and Dimensions

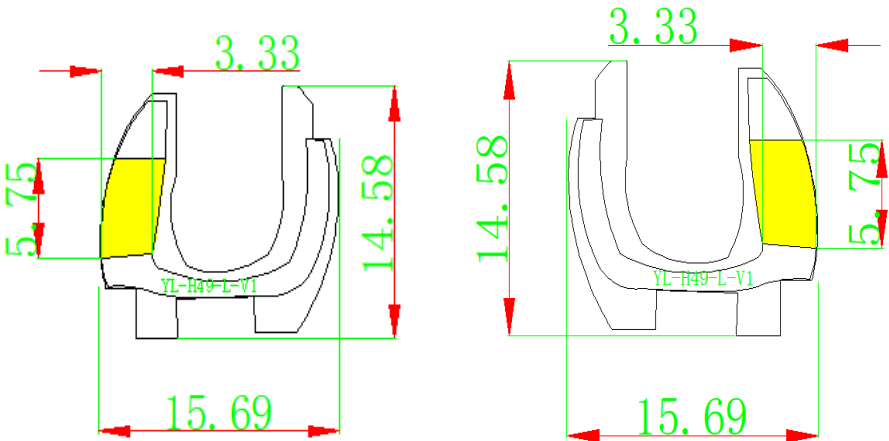
test point	Specification	Test Results
Dimensions	15.69mm*14.58mm	OK
golden finger	3.33mm*5.75mm	OK
drawing		

ANTENNA SPECIFICATION

2. 电气性能 Electrical Characteristics

2.1. 测试环境条件 Test Environment Conditions

温度 Temperature	Ordinary Temperature (5 to 35°C)
湿度 Humidity	Ordinary Humidity (25 to 85% RH)

2.2. 测试方法 Measurement method

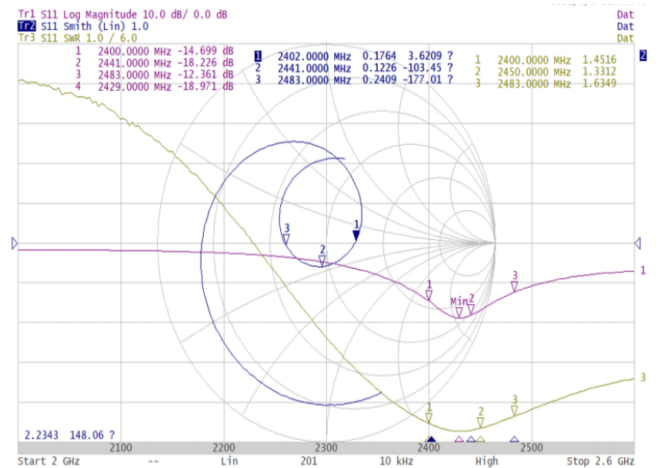
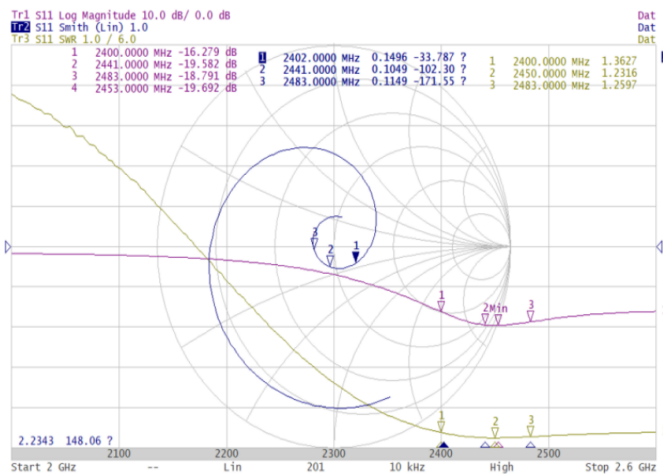
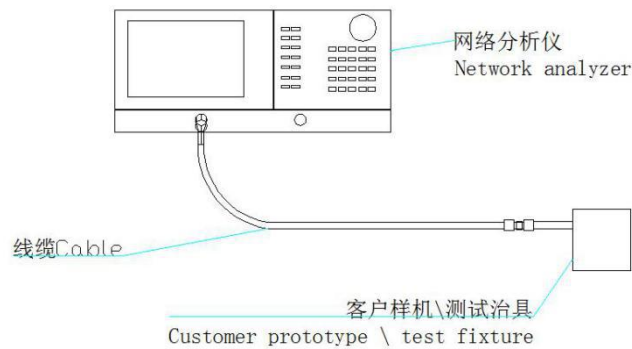

ANTENNA SPECIFICATION

2.3. 效率及增益 Efficiency and Gain

2.3.1. 测试系统 Test system

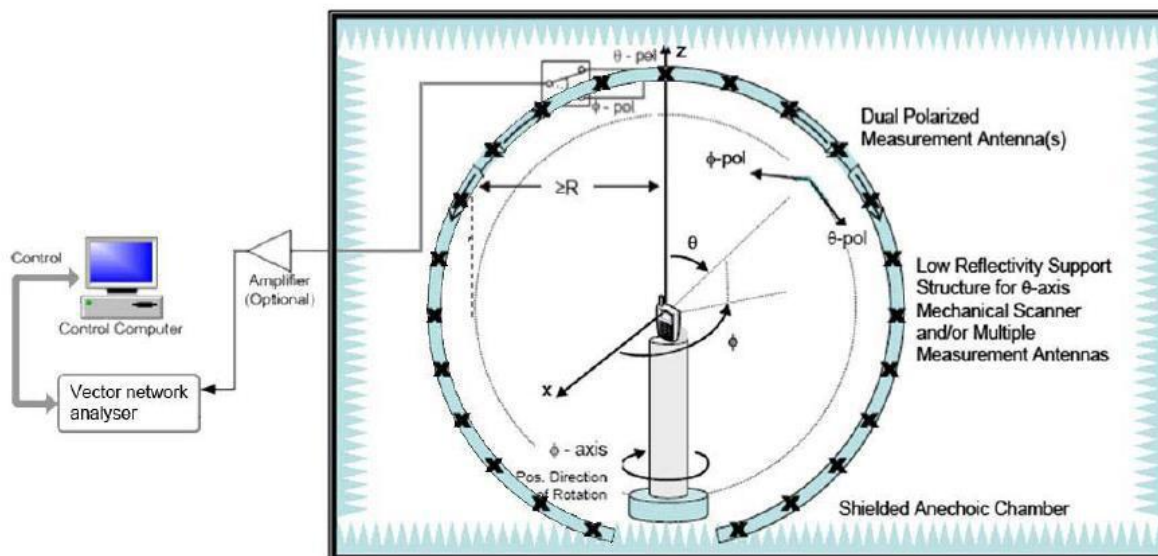

2.3.2. 无源数据 No-source test data

Gain&Efficiency 增益和效率			
frequency 频率(MHz)	gain 增益(dBi)	efficiency 效率(dB)	efficiency 效率
2400	1.02	-4.39	33.41%
2410	1.34	-4.01	34.11%
2420	1.41	-4.26	35.49%
2430	1.45	-3.79	36.10%
2440	1.51	-3.63	37.61%
2450	1.62	-3.54	37.35%
2460	1.49	-3.85	35.37%
2470	1.41	-4.07	33.21%
2480	1.35	-4.05	32.39%
2490	1.09	-4.21	30.80%
2500	1.03	-4.25	30.50%