



# **NSCaster**

## **User Guide**

**REV 1.0**

**Copyright © 2006-2018 NANJING NAGASOFT CORPORATION  
All rights reserved**

**1 HARDWARE SPECIFICATION .....1**

1.1 LIST ACCESSORIES.....	1
1.2 DEVICE PARAMETERS.....	1
1.3 MODEL.....	1
1.4 INTERFACE DIAGRAM.....	2
1.4.1 Back Interface.....	2
1.4.2 Side Interface.....	2
1.4.3 Bottom interface.....	3
<b>2 INSTALLATION AND COMMISSIONING.....</b>	<b>3</b>
<b>3 SOFTWARE FEATURES.....</b>	<b>6</b>
3.1 NSCASTER MAIN INTERFACE.....	6
3.1.1 PGM.....	7
3.1.2 SDI Channel.....	7
3.1.3 HDMI Channel.....	7
3.1.4 NET Channel.....	8
3.1.5 DDR Channel.....	8
3.1.6 Image Overlay.....	9
3.1.7 PIP (Picture in Picture).....	11
3.1.8 Scoreboard.....	12
3.1.9 Audio Mixer.....	13
3.2 NSCASTER SETTINGS INTERFACE.....	14
3.2.1 Channel Recording.....	15
3.2.2 Recording.....	15
3.2.3 Streaming.....	16
3.2.4 Clock.....	19
3.2.5 Network.....	19
3.2.6 File Transfer.....	20
3.2.7 General Settings.....	22
3.2.8 About.....	23
<b>4 QUESTIONS AND ANSWERS.....</b>	<b>23</b>

# 1 Hardware Specification

## 1.1 List Accessories

Name/Model	Package	Specification	Number of Pieces	Actual Quantity	Remarks
Main device	Carton packaging	NSCaster	1	1	
Power supply and power cord	Carton packaging	Standard	1	1	
WIFI antenna	Carton packaging	Standard	1	1	
User manual	Carton packaging	Nagasoft Custom	1	1	
Warranty card certificate	Carton packaging	Nagasoft Custom	1	1	

## 1.2 Device Parameters

Device Item Name	Description
Chassis	Portable case, built-in with 11.6-inch high-definition touch screen
Dimensions	294mm*193mm*54mm (W x H x D)
Weight	1.25KG
Powered by	100~240V AC
Transport box	Carton
Operating temperature	-10-50°C
Storage temperature	-20-70°C
Operating humidity	10~90% no condensation
Impact resistance	15g
Vibration resistance	10-100Hz 1.25g
Altitude	Below 4000 meters

## 1.3 Model



Standard Version

## 1.4 Interface Diagram

### 1.4.1 Back Interface

1) The back interface of the standard version is shown below:

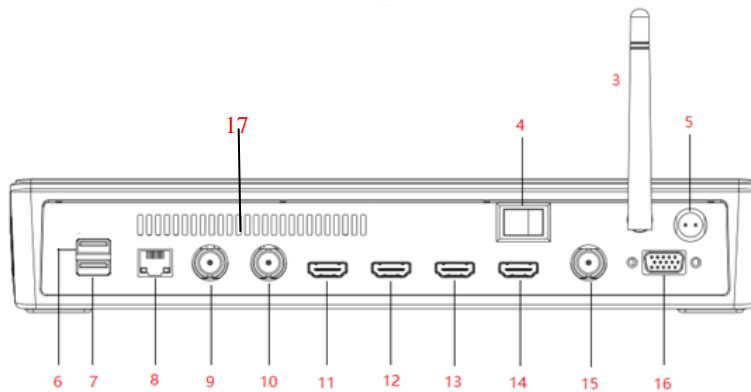

1	/	7	USB3.0	13	HDMI Display interface
2	/	8	Gigabit Ethernet port	14	HDMI PGM Output
3	WIFI antenna	9	SDI-1 Input	15	SDI PGM Output
4	Switch	10	SDI-2 Input	16	TALLY
5	Power supply (DC19V)	11	HDMI-1 Input	17	Cooling port
6	USB2.0	12	HDMI-2 Input		

### 1.4.2 Side Interface

The side interface of the standard version is shown below:

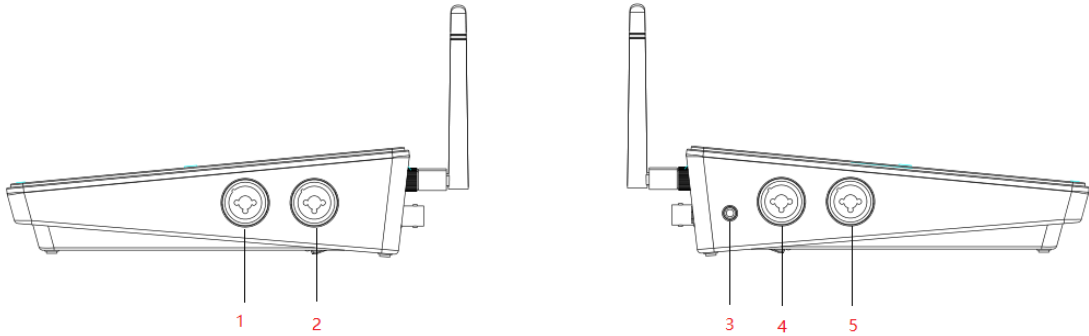

1	XLR/TRS balanced input L	4	XLR/TRS balanced output L
2	XLR/TRS balanced input R	5	XLR/TRS balanced output R
3	3.5mm monitor		

### 1.4.3 Bottom interface

1) The bottom interface of the standard version is shown:

## 2 Installation and Commissioning

- 1) Open the box, then take out the power cord and NSCaster device. After that, lay the device on a stable surface.
- 2) Connect the power cord and the corresponding WIFI . Then, use a network cable to connect to the RJ45 Gigabit Ethernet port.
- 3) Connect the output of the AV equipment (such as camera) to the NSCaster device input interface.
  - The SDI/HDMI camera is connected to the SDI/HDMI input via SDI/HDMI cable as shown below:



- The mixer is connected to the TRS MIC input port through the TRS cable, or the XLR cable is connected to the XLR input as shown below:

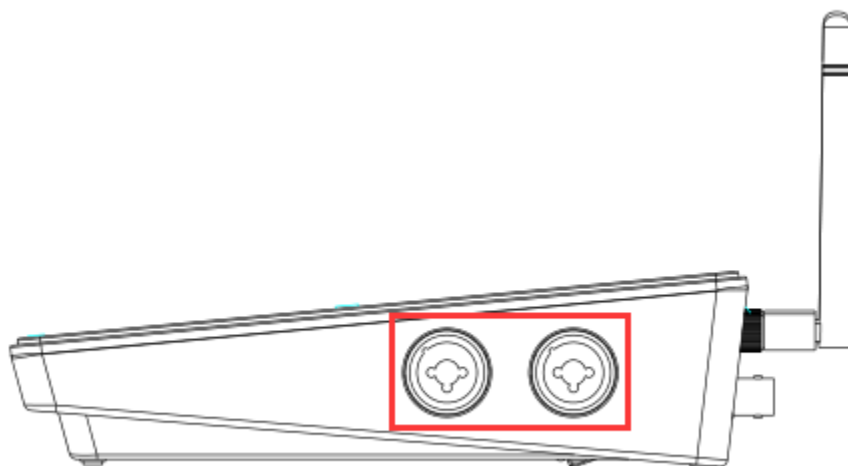

4) In order to connect the NSCaster device output port to the monitor, it has divided into following categories:

- The SDI monitor is connected to the SDI output via an SDI cable.



- The HDMI monitor is connected to the HDMI output via HDMI cable.



5) Connect the sound output of the NSCaster device to an external device or monitor.

- Connect to the TRS MIC output through the TRS cable, or connect to the XLR output interface through the XLR cable as shown below:

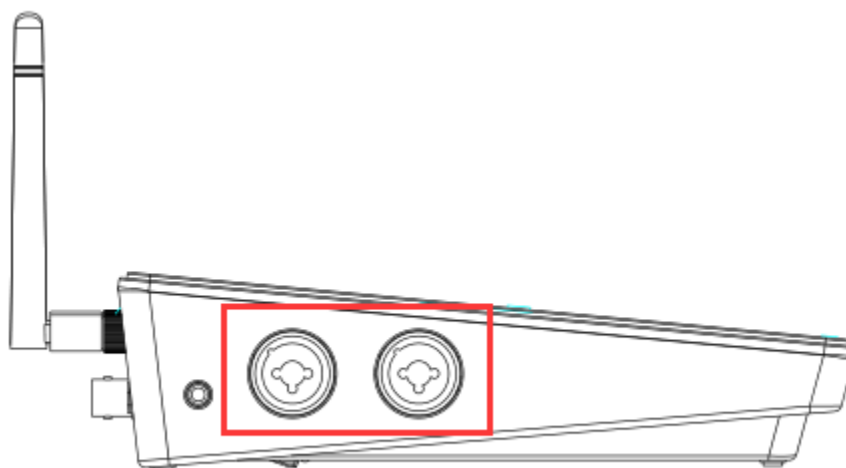

- Connect to the call output interface through a 3.5mm audio cable as shown below:

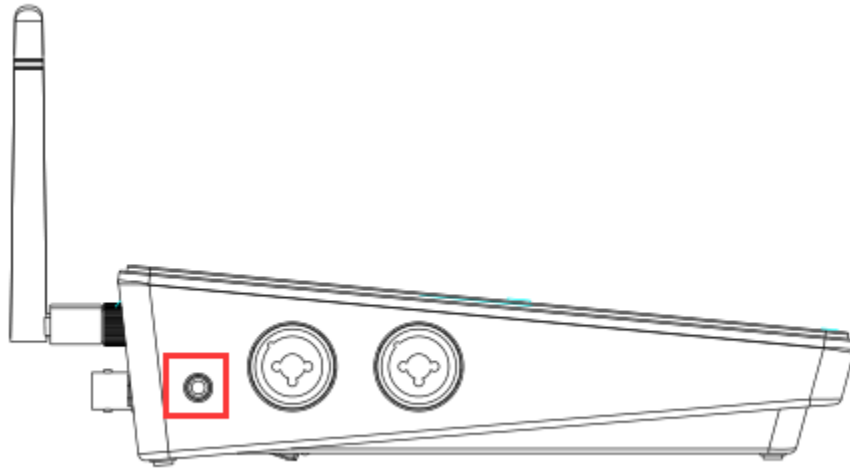

6) To start the NSCaster device, just press the power button on the NSCaster device as shown below:

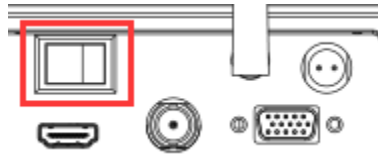

7) After the NSCaster device is started, it will enter the main interface of NSCaster as shown in the following figure:

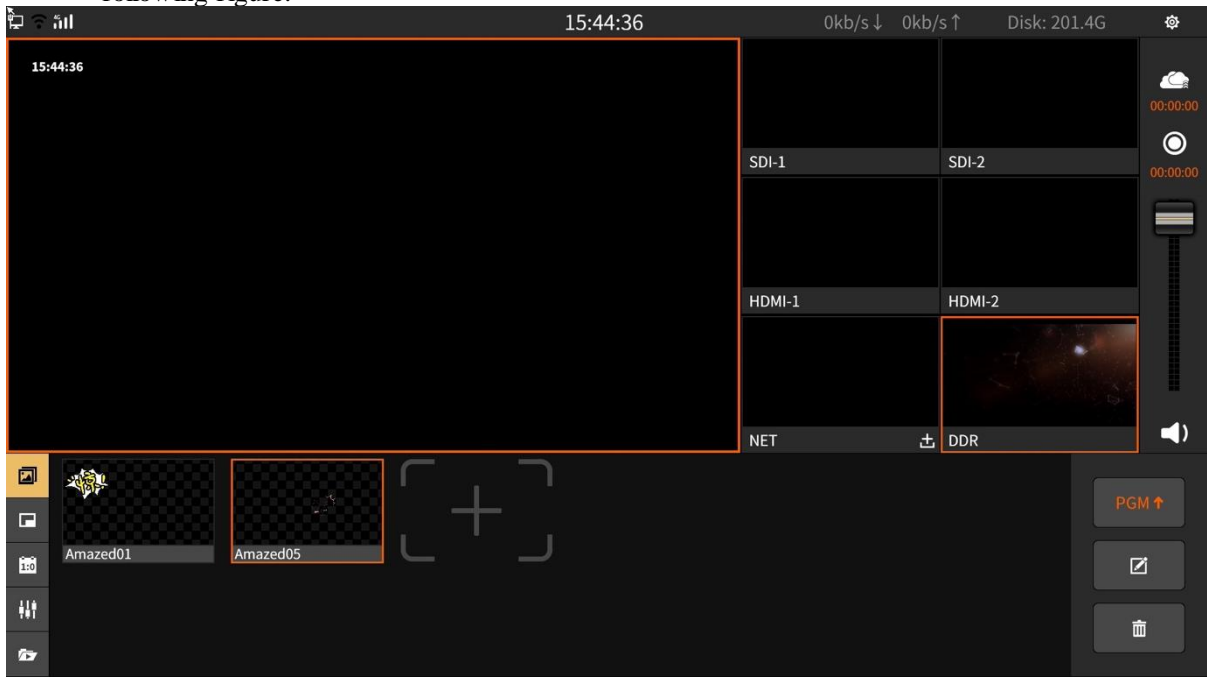

- 8) The SDI video signal and HDMI video signal are directly loaded into the main interface.
- 9) To load NET signal,select " " in the NET channel and enter the stream in the pop-up stream edit box.
- 10) To load DDR signal, select the DDR button in the DDR alternate video window, and select one of the video sources, then click Play to load the video into the DDR channel.
- 11) Select the output channel and press the record button " " to start record.
- 12) To start switching, tap once on the channel you want (SDI-1,SDI-2,HDMI-1,HDMI-2,NET,DDR) and it will switch to PGM.

13) Start uploading the picture on PGM as shown below:



- 14) Press again the record button to stop recording.
- 15) Check whether all the recording files are normal. The recording file is saved in the “Recording” folder which located at the “File Transfer” interface.
- 16) Press the Power On/Off button to turn off the NSCaster device.
- 17) Turn off the power switch of the device, unplug the power supply, and unplug all input and output video cables and antennas, then keep the NSCaster device properly.

### 3 Software Features

#### 3.1 NSCaster Main Interface

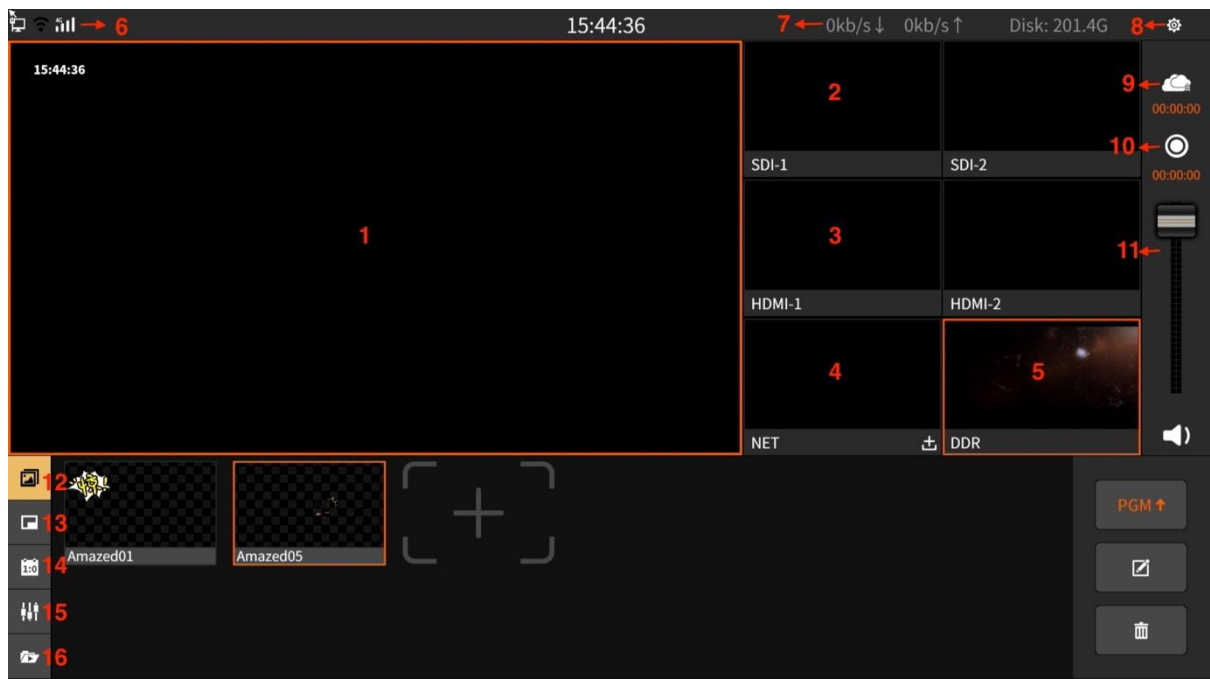

NO	Name	NO	Name
1	PGM	9	Streaming control
2	SDI input channel	10	Recording control
3	HDMI input channel	11	Tuning control for total mix output
4	NET input channel	12	Image overlay
5	DDR display channel	13	PIP (Picture in picture)



6	Network status display	14	Scoreboard
7	Resource usage monitoring status	15	Audio mixer
8	Settings button	16	DDR

### 3.1.1 PGM

**PGM channel:** Monitor the screen that being broadcast. Single tap on the channel you want (SDI-1,SDI-2,HDMI-1,HDMI-2,NET,DDR) and it will switch to PGM as shown below:

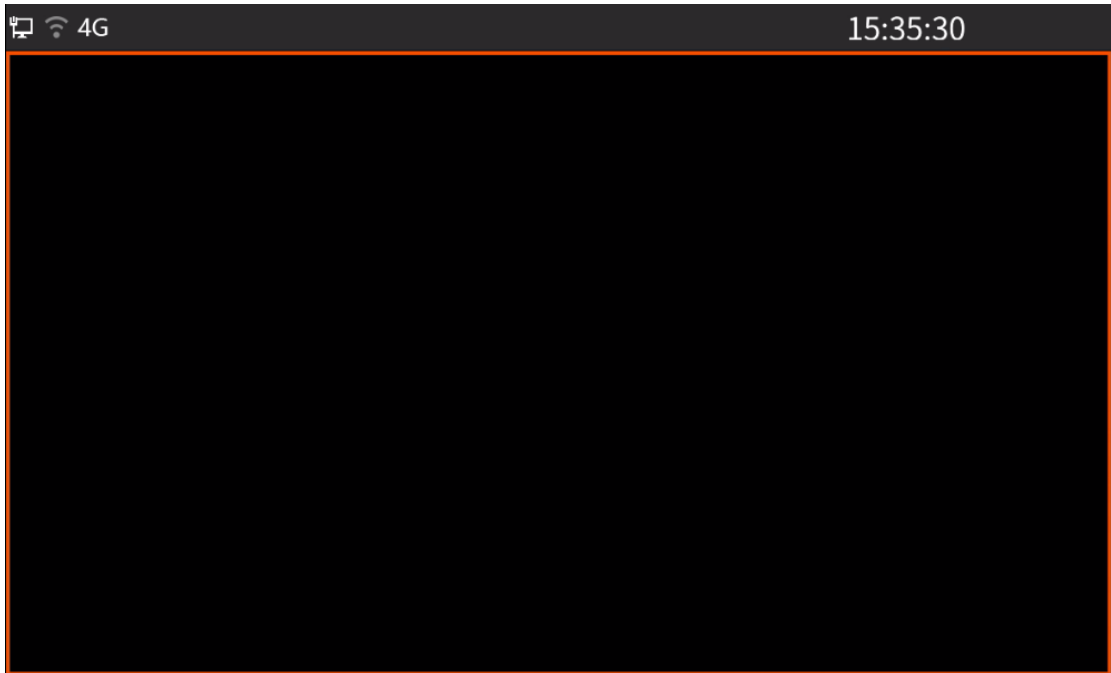

### 3.1.2 SDI Channel

SDI-1 and SDI-2 can be connected to SDI cameras or other devices as shown below:



### 3.1.3 HDMI Channel

HDMI-1 and HDMI-2 can be connected to HDMI cameras or other devices as shown below:



### 3.1.4 NET Channel

The NET channel is used to load network streams and the supported formats are: rtmp/rtsp. Click “” to enter the network stream editing interface as shown below:

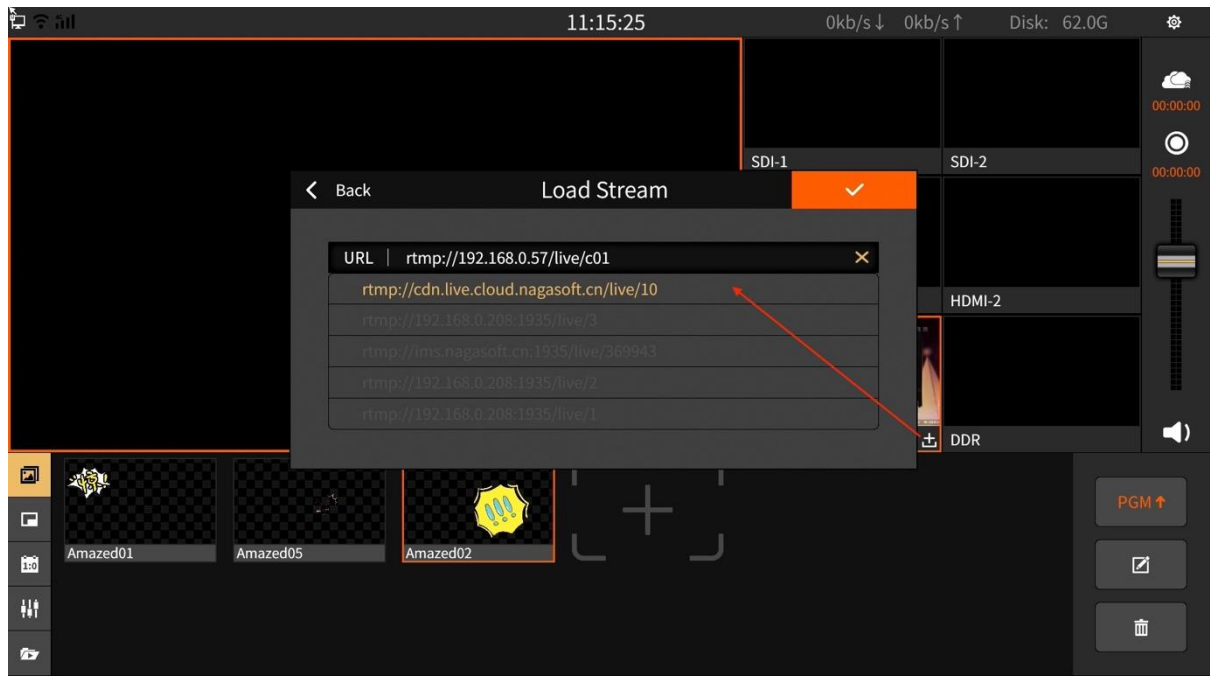





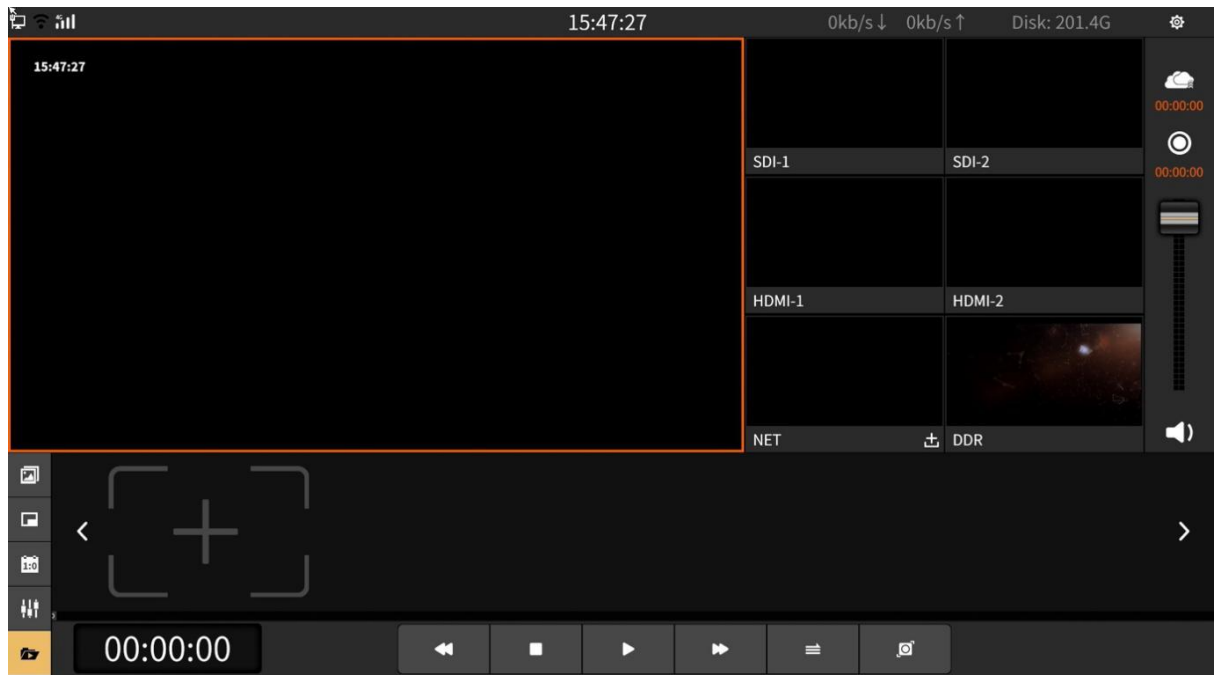



### 3.1.5 DDR Channel

The DDR channel is used to load video footage as shown below:





1) The button for loading video material is as follows:

- Button  : Add video
- Button  : Play/pause video
- Button  : Stop
- Button  : Back 10 seconds
- Button  : Fast forward 10 seconds
- Button    : Separately, play in list order, play single video loop and play in list loop
- Button  : The progress adjustment button is enlarged to adjust the video progress



### 3.1.6 Image Overlay

Image overlay panel can publish image to the PGM monitor. It support png image format and location movement of images as shown below:



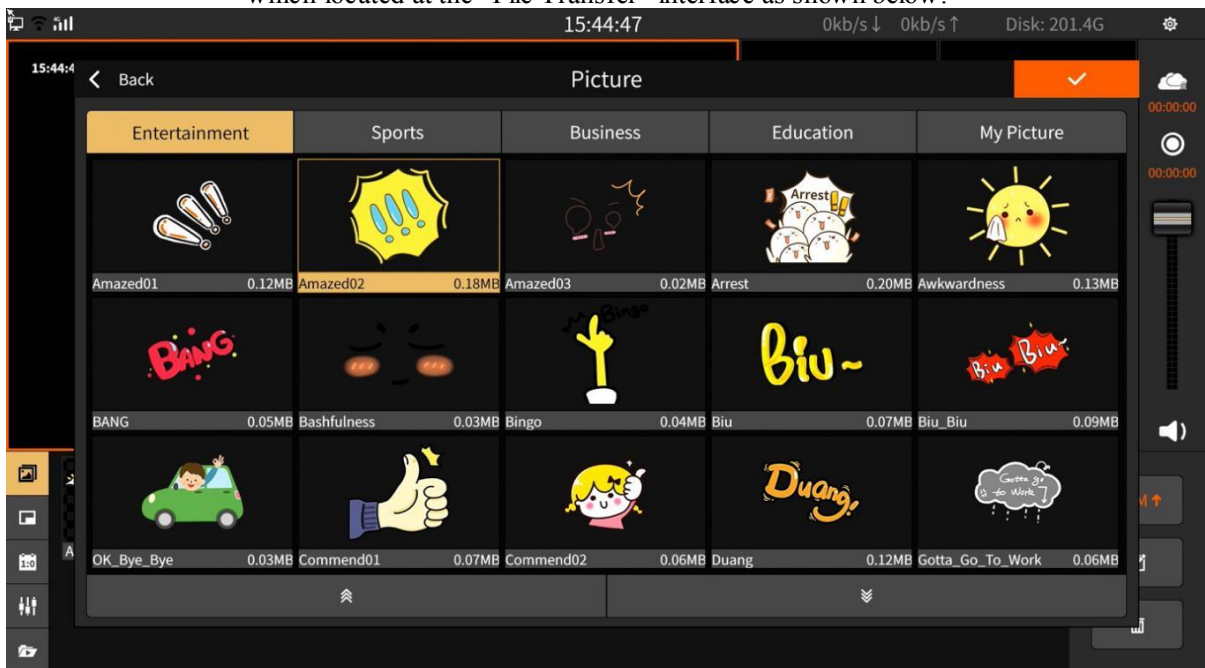



- 1) Click the button “” to enter the photo editing interface, and then click the button “” to add a picture. There are two ways to source images:
  - Online download. Click "Download" to download.
  - Customize “My Picture”. You can copy the picture to the “My Pictures” folder which located at the “File Transfer” interface as shown below:

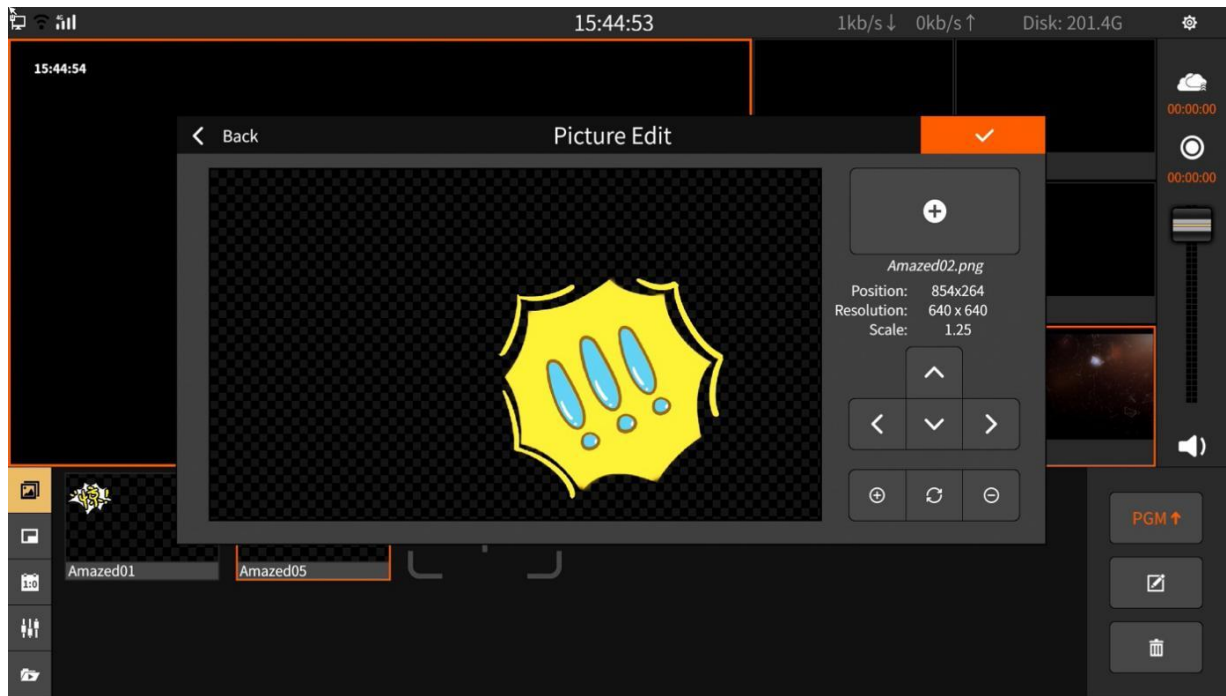

- 2) Click  to send it to the PGM, and click again to not display.
- 3) Click  to enter the photo editing interface as shown below:



Button operation is as follows:

- Four button  : Adjust the position of the picture in the up, down, left, and right directions
- Button  : Zoom in
- Button  : Zoom out
- Button  : Restore image to initial state

4) Select the image and click  to delete the image.

### 3.1.7 PIP (Picture in Picture)

Picture-in-picture can display multiple channels on the PGM channel. Click  to display the selected picture-in-picture mode in the PGM channel, where A/B/C/D represent the screen of the channel. For example, select A in SDI-1 channel and the A area of the PGM will display the screen of SDI-1 channel. The channel screen of A/B/C/D area on the PGM channel supports real-time switching. The picture-in-picture template is divided into the following two types:

1) No background image template as shown below:

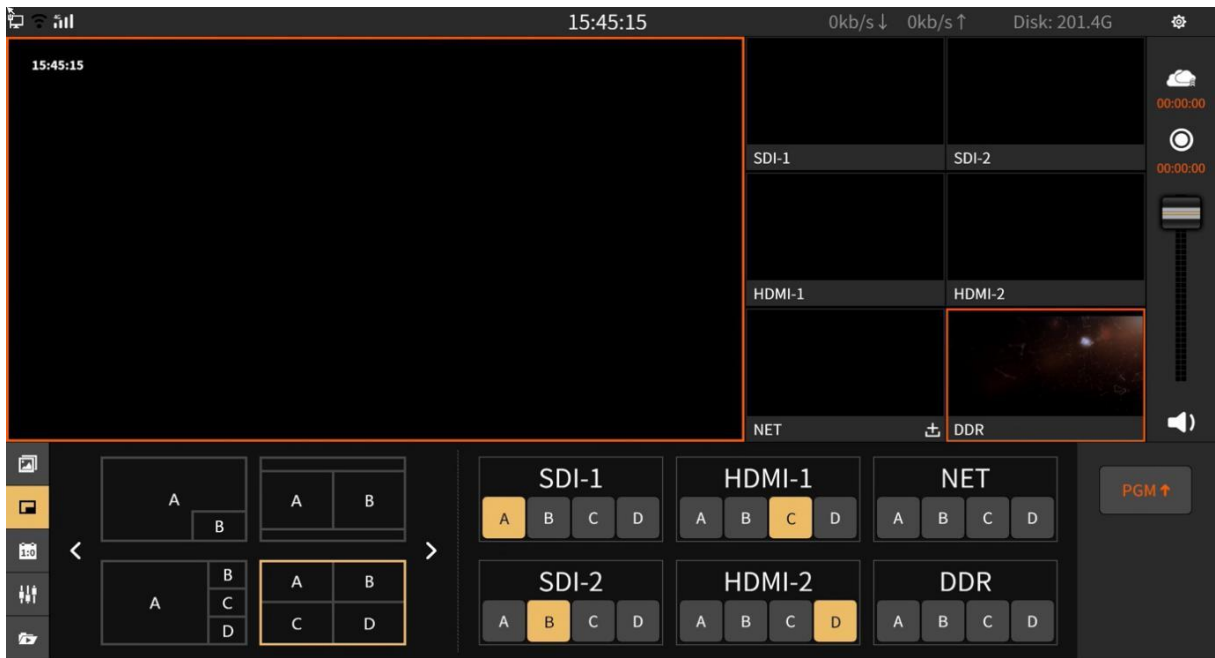

- 2) Add background image template. The background image is stored in the “Picture Clips” folder which located at the “File Transfer” interface. Click “Custom Background” to select "My Pictures" as shown below:



### 3.1.8 Scoreboard

The scoreboard can record the score of the live match in real time as shown in the figure below:



1) Button operation is as follows:

- Button **PGM ↑**: Display the score board to the PGM channel and click again to cancel the display.
- Button **Template**: Choose the template of the scoreboard. The templates are general, basketball, football, table tennis, badminton and volleyball. It also support online download. In order to download, just click the “Download” button as shown below:

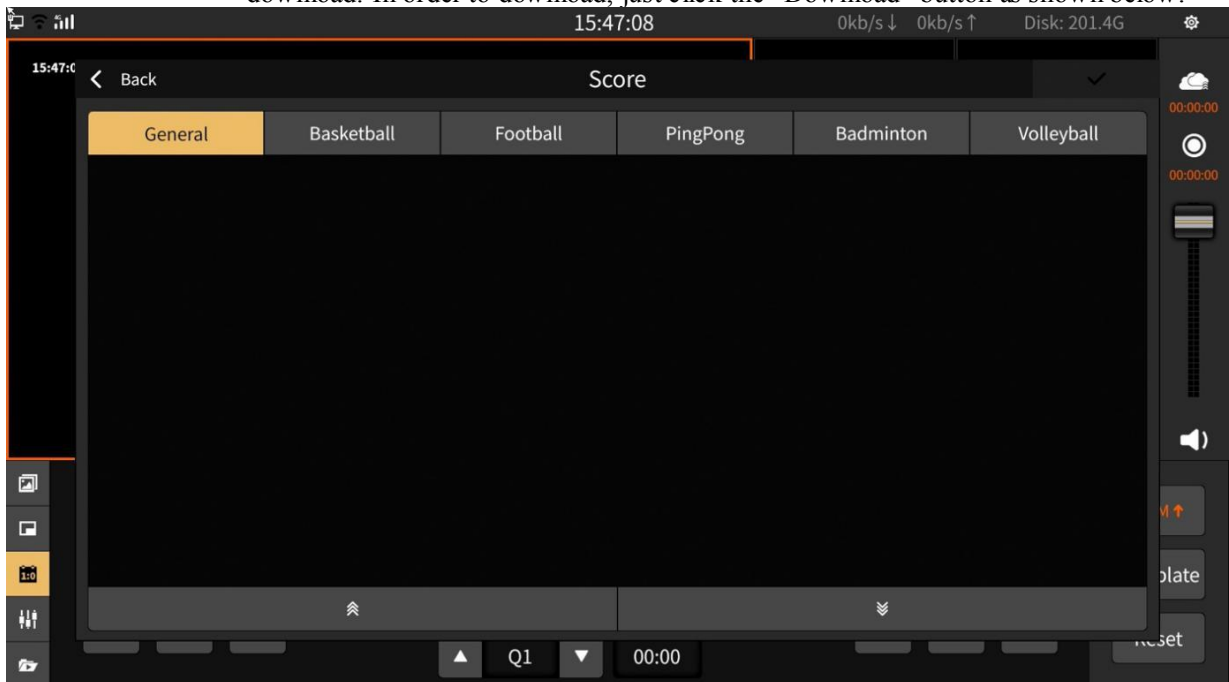

- Button **+ 1 -**: “+/-” can “increase/decrease” scores in real time.
- Button **Start**: Start/pause timing. The status will become yellow highlight when it start. **+ 02:51 -** “+/-” can “increase/decrease 1 second” in real time.
- Button **Reset**: Clear the score and timing.

### 3.1.9 Audio Mixer

The mixer is used to control the gain and mix of all input and output audio as shown below:

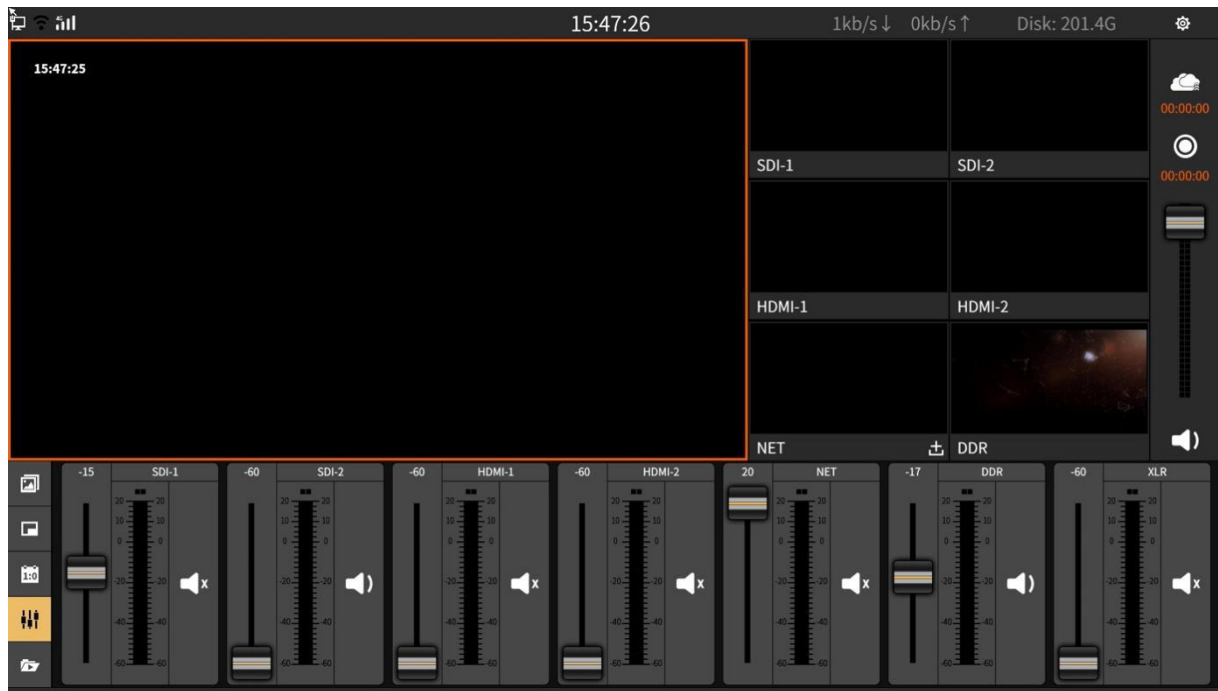

- 1) Button operation is as follow:
- Button : Mixing output.
  - Button : Mute.
  - Button : Volume adjustment fader.

## 3.2 NSCaster Settings Interface

Click to enter the setting interface. Respectively, there are "Channel Recording, Recording, Streaming, Clock, Network, File Transfer, General Settings, About" module as shown below:



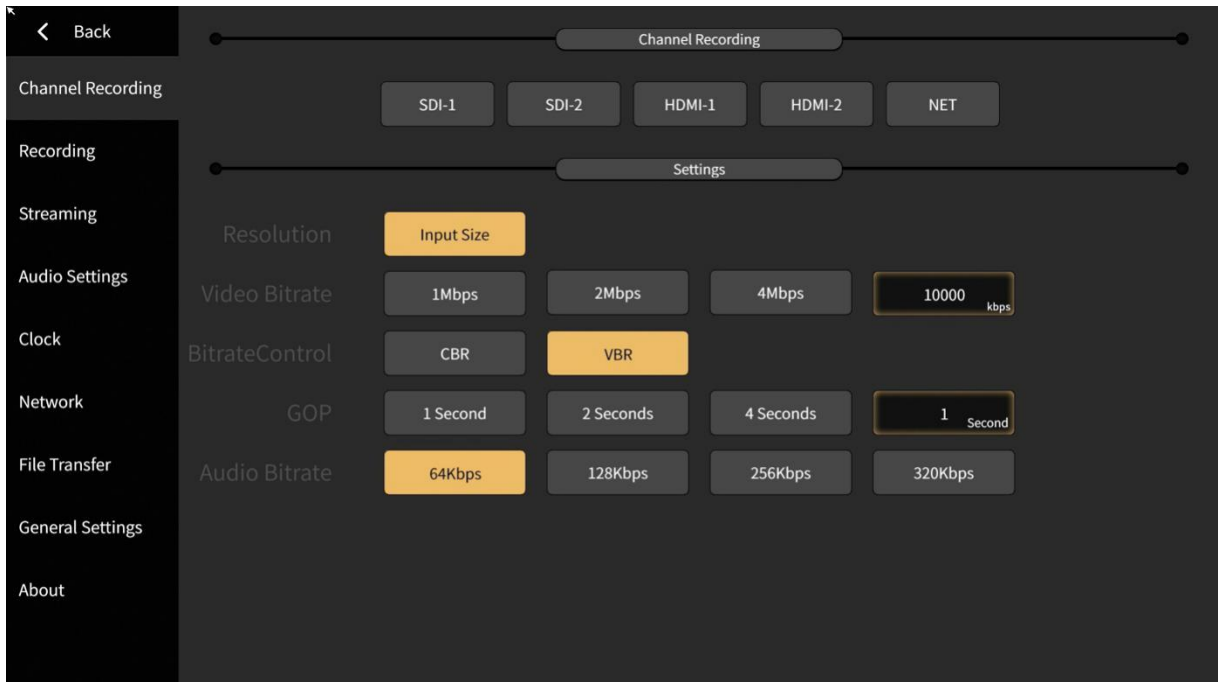



### 3.2.1 Channel Recording

It can record channel audio and video and also support recording of SDI-1, SDI-2, HDMI-1, HDMI-2 and NET channels. The recorded files are stored in the “Record/channel” folder which located at the “File Transfer” interface.

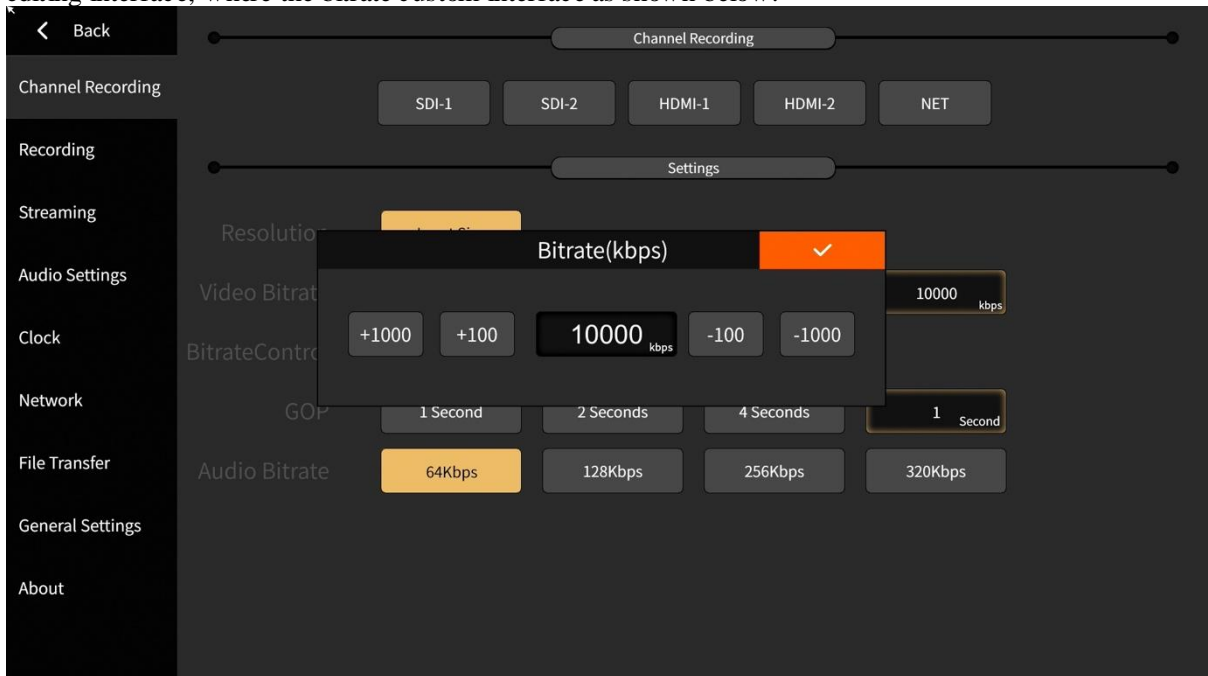
The bitrate and GOP in the interface can be customized. Click the custom box to pop up the editing interface, where the bitrate custom interface as shown below:



### 3.2.2 Recording

Record the contents of PGM. Click the button  on the “Main Interface” to start recording, and click again to stop. The recorded files are stored in the “Record/pgm” folder which located at the “File Transfer” interface as shown below:

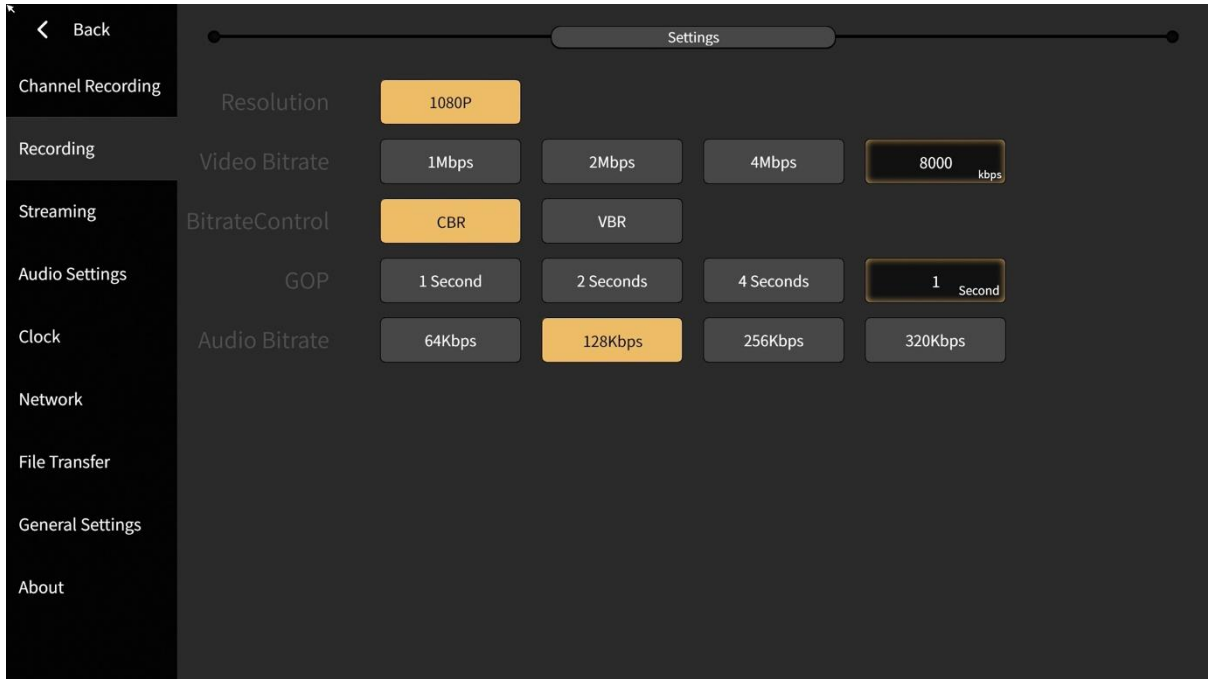

The bitrate and GOP in the interface can be customized. Click the custom box to pop up the editing interface, where the GOP is customized as shown below:

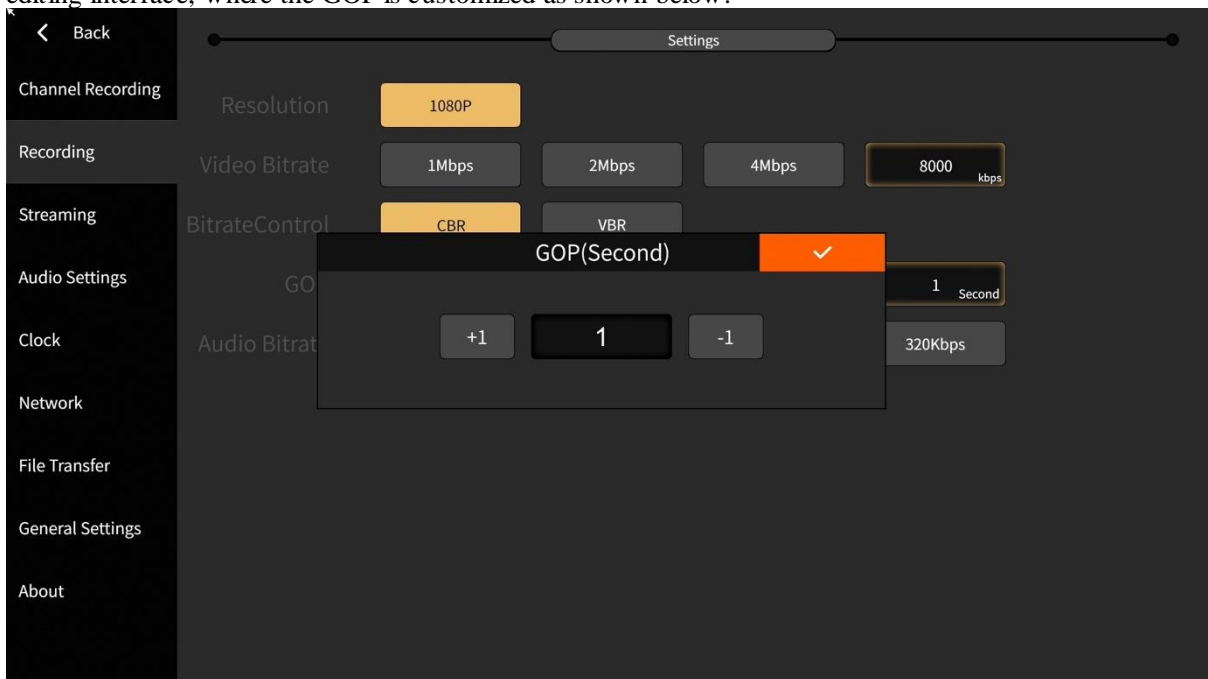

### 3.2.3 Streaming

PGM streaming is sent to VJLive3, FMS, WOWZA, etc. through RTMP protocol for live streaming. Click the button  on the “Main Interface” to start the streaming and click again to stop. Video bitrate and GOP can be customized as shown below:

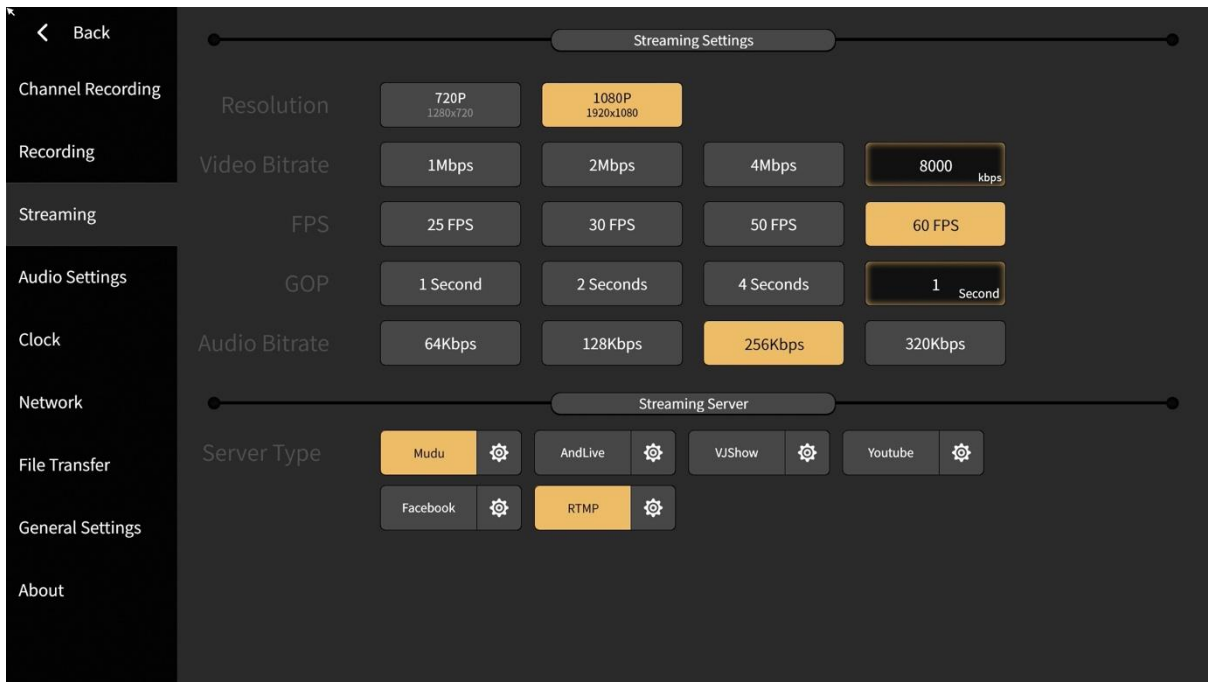

- 1) Select the server type as "RTMP" and if channel push protection is set, then it require user to enter the username and password. If not, just ignore it. The format of "rtmp://" is: ip.port/live and "stream name" is the name of the channel as shown below :

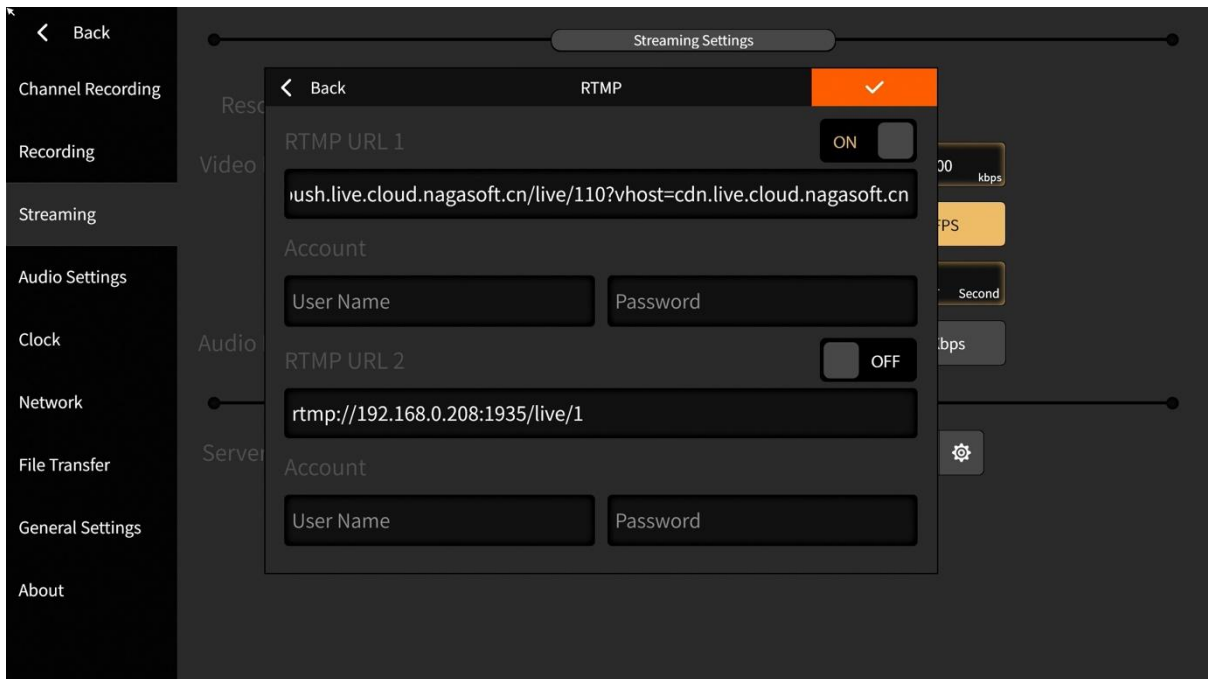

- 2) Select the server type as "Mudu". First, you must first register on the Mudu live platform, then fill in the username and click on the authorization to get the channel and encoding information as shown below :

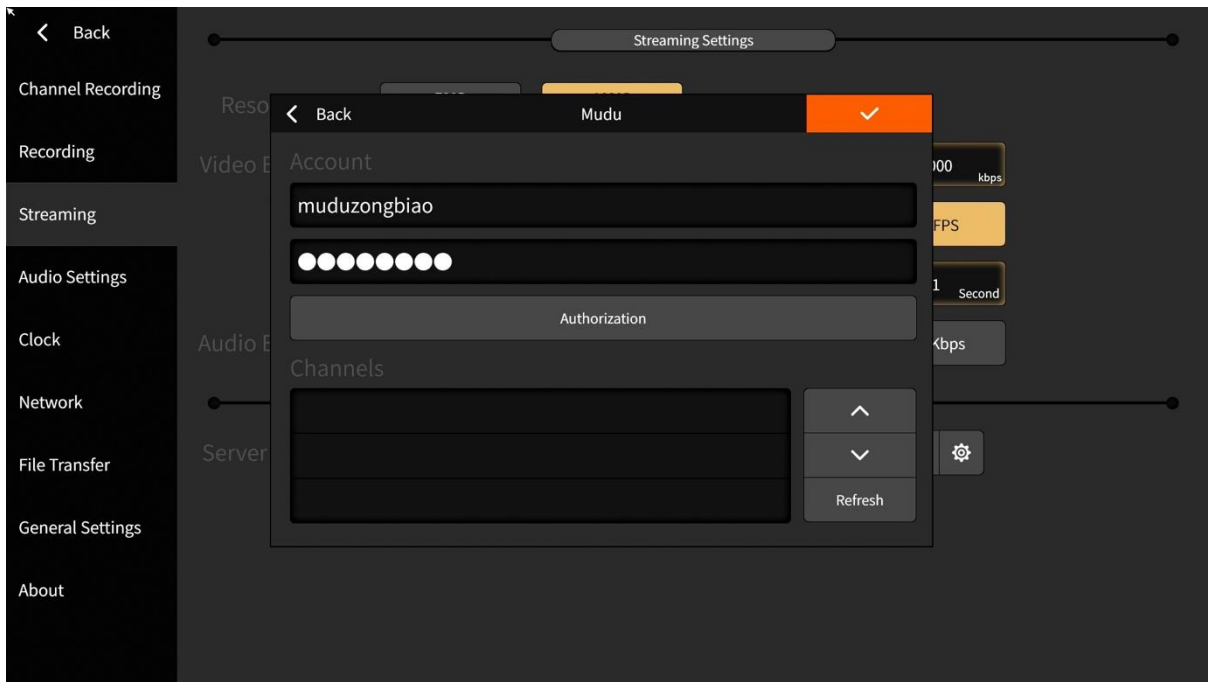

- 3) Select the server type as “AndLive”. First, you need to enter the username and password, then log in to get the activity list as shown below:

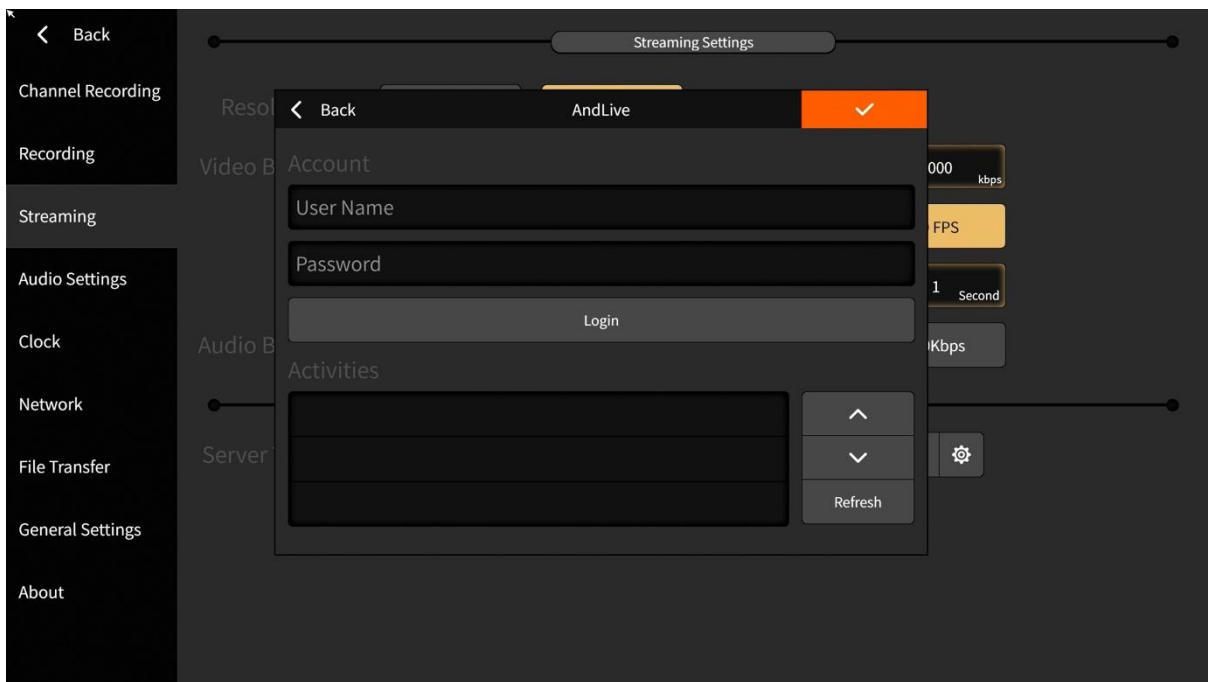

- 4) Select the server type as “VJShow”. First, you need to enter the live authorization code and click the "Authorization" button. If you want to replace the authorization code, you will need to “cancel” the authorization first as shown in the figure below:

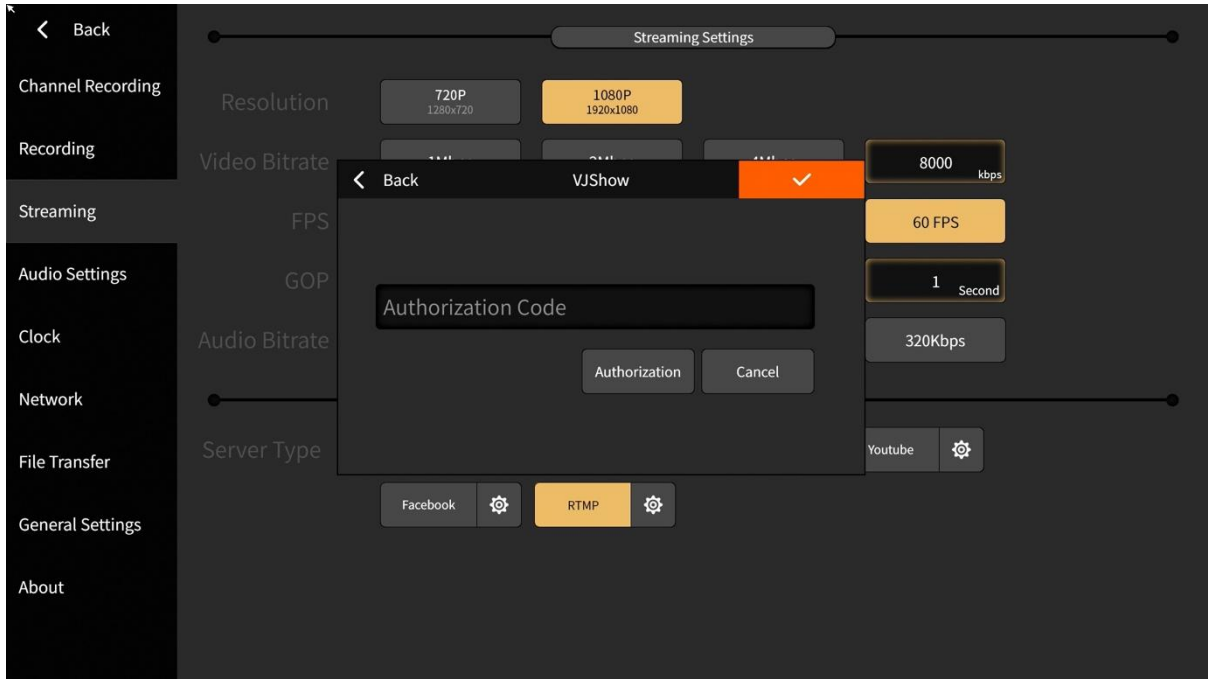

### 3.2.4 Clock

Clock configuration status will let user know whether is on/off based on the status. If the status is “ON” means the clock is on right now and if the status is “OFF”, means that the clock is off. After being turned on, the current time can be displayed on the PGM monitor, and the format and the position of the clock support real-time switching as shown below:

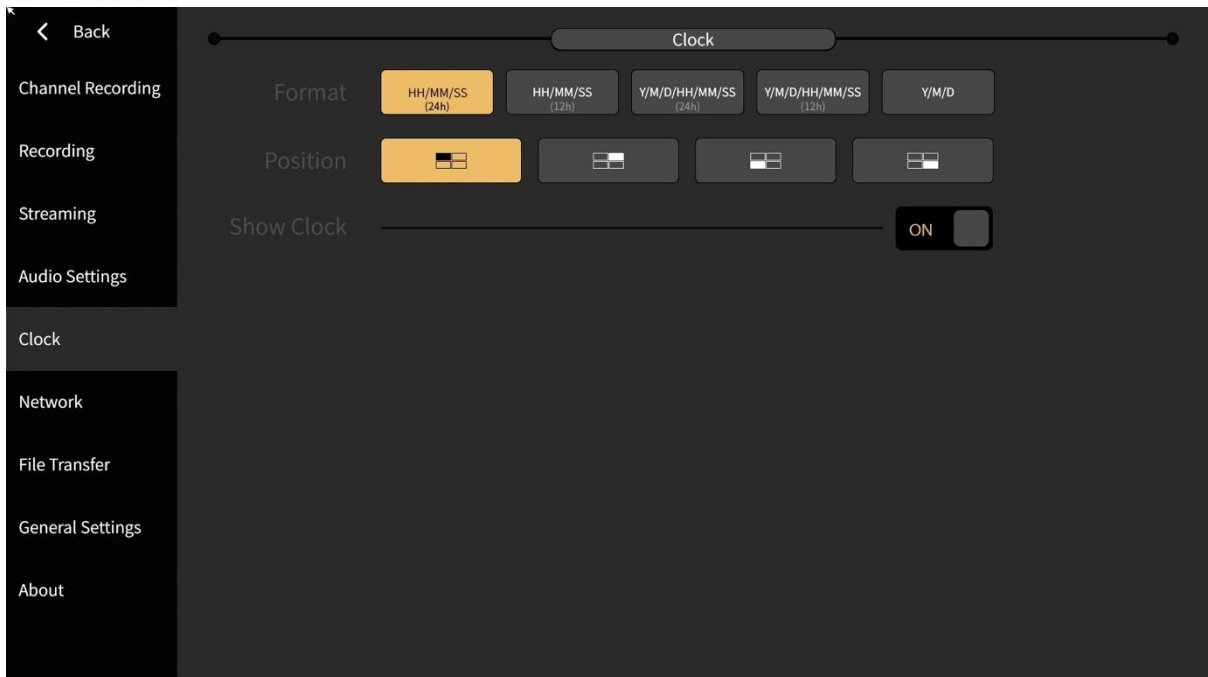



### 3.2.5 Network

NSCaster supports ethernet, WIFI. The status of the connection  is displayed on the main interface, highlighted to indicate that it is connected.

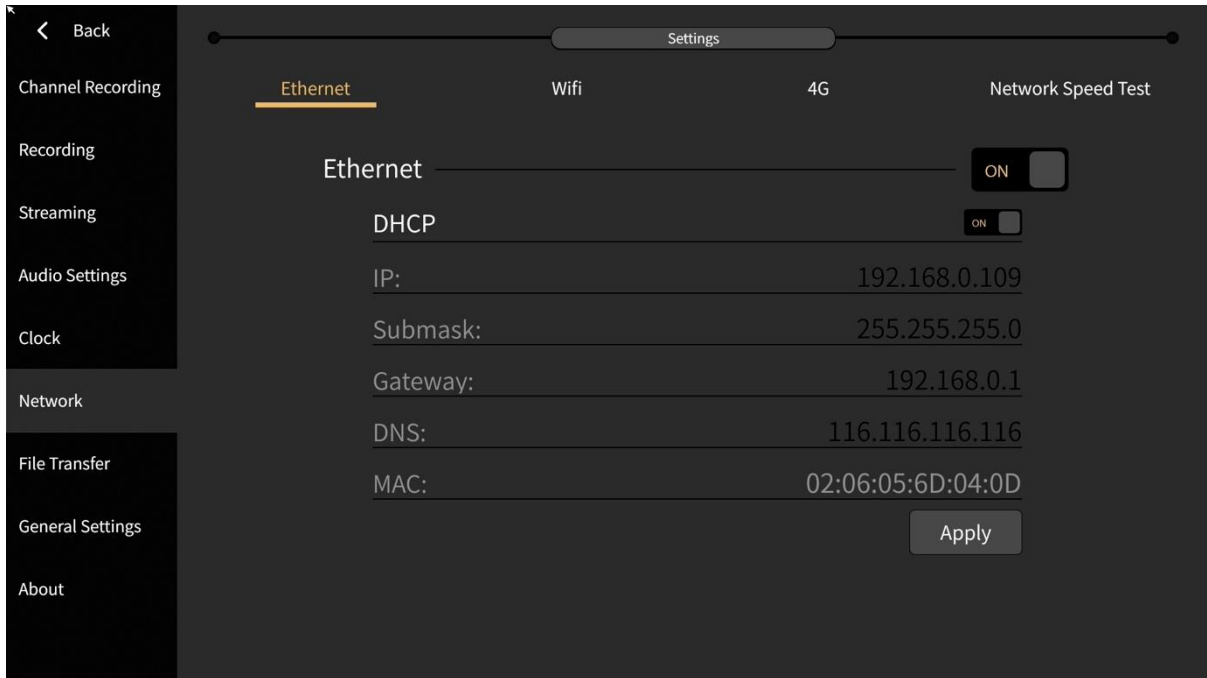
- 1) **Ethernet:** The default boot and the access network cable will automatically obtain the IP. Open DHCP and click “Apply” to get the IP address automatically, or turn off DHCP to manually modify the IP address as shown below:



- 2) **WIFI:** Select the WIFI you want to connect and enter the correct password. Click the button   to scroll up and down.

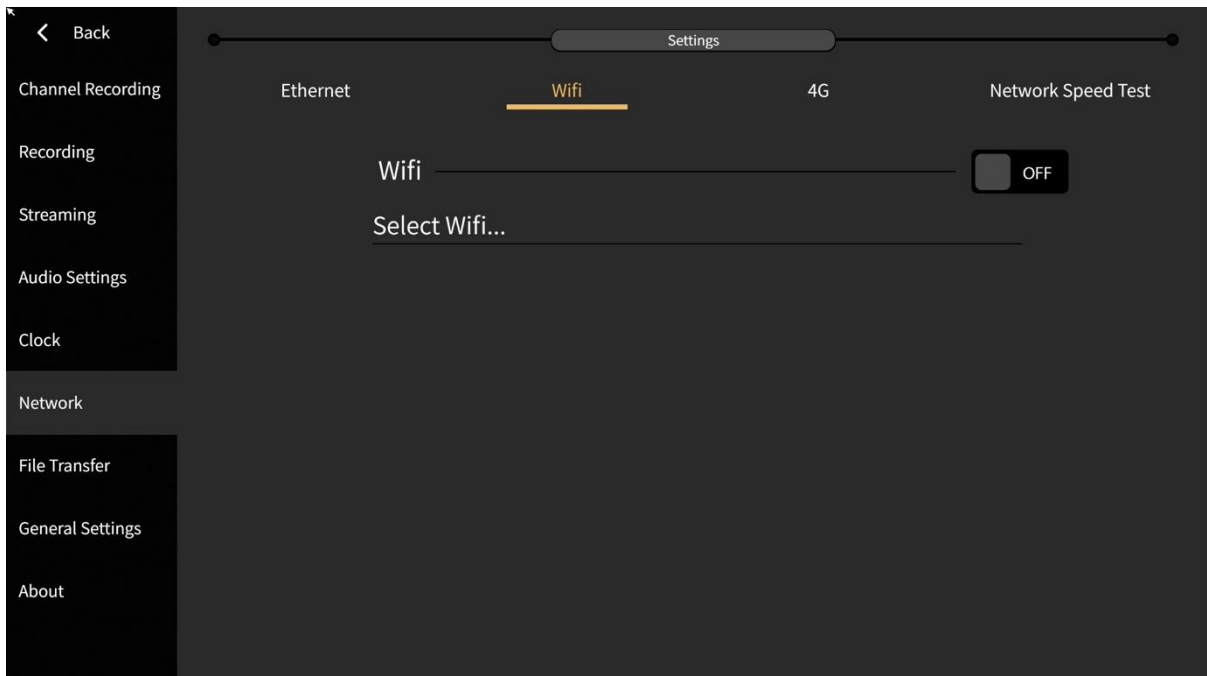

### 3.2.6 File Transfer







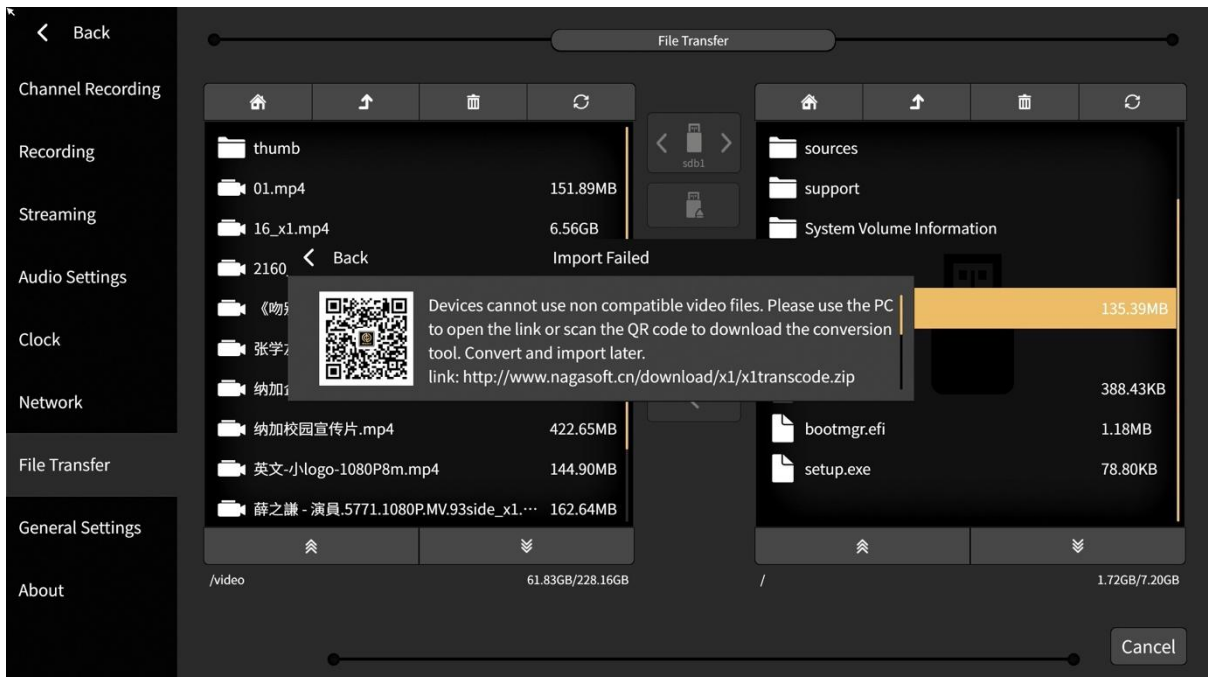

File transfer between local files and USB flash drives as shown below:



1) Local folder directory description:

- CG material: Store CG file
- Picture material: Store custom images, which can also be used for image overlay function and picture-in-picture custom template background.
- Recording: The "channel" folder stores channel recording files, "pgm" folder to store PGM recording files.
- Video material: Store DDR playback video. It only supports mp4 format and goes to B frame video, and if the format is incorrect, it will prompt "Import failed". (Solution: Download the transcoding tool to transcode the video, the link is: <http://cdn.nagasoft.cn/download/x1/x1transcode.zip>) as shown below:



- 2) The button operation is as follows:
- Button  : Return to the main interface directory of the file
  - Button  : Return to the previous directory
  - Button  : Delete files
  - Button  : Refresh
  - Button  : Choose a different USB flash drive/ different partitions of the same USB flash drive
  - Button  : Slide up and down
  - Button  : Copy locally to a USB flash drive
  - Button  : Copy from USB flash drive to local
  - Button  : During file copying, cancel the copy by the cancel button. Copy progress can refer to the percentage status of the progress bar.
  - There are two ways to select a file: First is "single choice" which click on the corresponding file to select and the selected state is yellow highlighted. The second is "multiple selection" which long press the corresponding file or folder to select and the selected state is orange highlighted. To cancel the multi-select status, click the refresh button.

### 3.2.7 General Settings

The general configuration interface is divided into the following functions:

- 1) **Project FPS.** It support 1080p25, 1080p30, 1080p50 and 1080p60 formats. After switching the system, you need to click the "Apply" button to restart the software automatically as shown below:

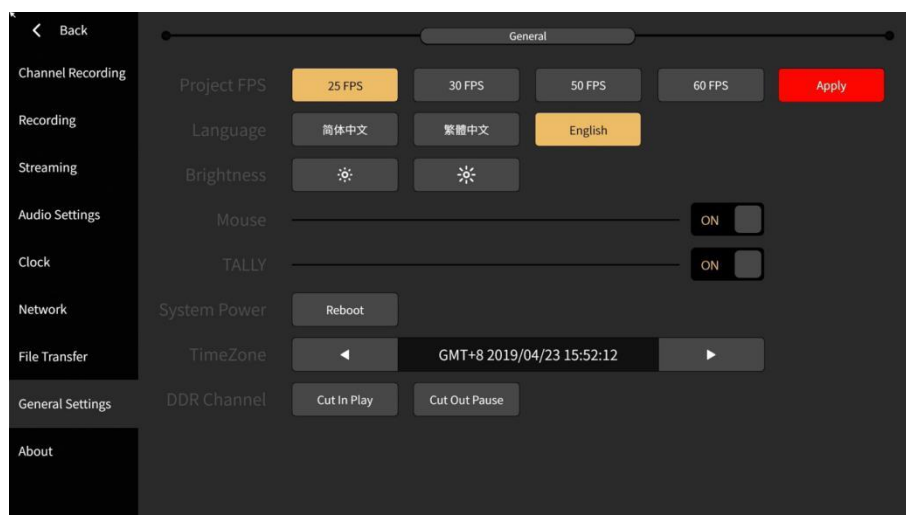

- 2) **Language.** It support real-time switching language: Simplified Chinese, Traditional Chinese, English.
- 3) **Brightness.** Adjust the brightness of the screen according to the actual scene.
- 4) **Mouse.** "ON" status means that mouse is operable, "OFF" status means that mouse is not operable.



### 3.2.8 About

The device information interface displays the details of the current device. In that interface, user can also do the software update and firmware update when there is available as shown below:

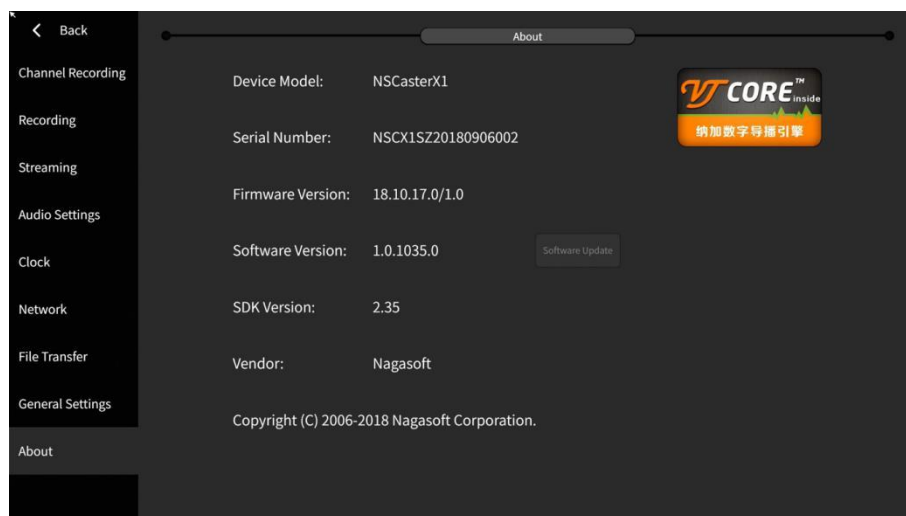

- 1) The button operation is as follows:
  - **Software Update:** It will pop-up update interface and update instructions.
  - **Download the update:** Download the latest version.
  - **Cancel download:** Cancel the currently downloaded version.
  - **Restart:** Install the download version and restart the software.

## 4 Questions and Answers

### Q1. What should I do if the camera signal is not displayed?

Ans: NSCaster is automatically identify the input signal. HDMI input supports SD and HD all formats . If the camera signal cannot be displayed, please confirm that the camera is turned on and make sure the camera is connected to the NSCaster device input port properly. If all of the above are normal, you can connect the camera to the monitor to check whether there is a signal or not. If all of the above are normal, please call us at 400-086-0078 for technical support.

### Q2. What should I do if the live webcast is not stream?

Ans: First, use the network test function to test and make sure that the device is properly connected. After that, check the upload and download speed whether is normal or not. Then confirm whether the server address, port, and publishing point/flow name are correct.

### Q3. What can I do if WIFI cannot connect?

Ans: First, check if the WIFI antenna is connected properly. After that, check if the WIFI is enabled in the software.

### Q4. What should I do if the device fails to boot?

Ans: First, check if the power is plugged in, and the power switch is pressed to the power-on position. If all of the above are normal, please call us at 400-086-0078 for technical support.

#### FCC WARNING

This device complies with part 15 of the FCC Rules. Operation is subject to the following two conditions: (1) this device may not cause harmful interference, and (2) this device must accept any interference received, including interference that may cause undesired operation.

Any changes or modifications not expressly approved by the party responsible for compliance could void the user's authority to operate the equipment.

NOTE: This equipment has been tested and found to comply with the limits for a Class B digital device, pursuant to Part 15 of the FCC Rules. These limits are designed to provide reasonable protection against harmful interference in a residential installation. This equipment generates, uses and can radiate radio frequency energy and, if not installed and used in accordance with the instructions, may cause harmful interference to radio communications.

However, there is no guarantee that interference will not occur in a particular installation.

If this equipment does cause harmful interference to radio or television reception, which can be determined by turning the equipment off and on, the user is encouraged to try to correct the interference by one or more of the following measures:

- Reorient or relocate the receiving antenna.
- Increase the separation between the equipment and receiver.
- Connect the equipment into an outlet on a circuit different from that to which the receiver is connected.
- Consult the dealer or an experienced radio/TV technician for help.

To maintain compliance with FCC's RF Exposure guidelines, This equipment should be installed and operated with minimum distance between 20cm the radiator your body: Use only the supplied antenna.