

Cash register manual

Model : NOVO-03

Instructions

Thank you for choosing our product.
Please read instructions carefully and keep it for further reference.

Notice

- Place the device in dry and clean environment
- Do not plug out with wet hands
- Do not scrape or hammer the screen
- Handle carefully with interface connection
- Clean the device with cloth; do not use chemical solvent that may harm electrical components
- In case of malfunction, please contact our technicians
- If you set password for screen-lock, please keep the password properly. We are unable to retrieve the password for you
- Please be careful when you delete/modify log in account/password

Parameters

POS Device - Front



POS Device - Back

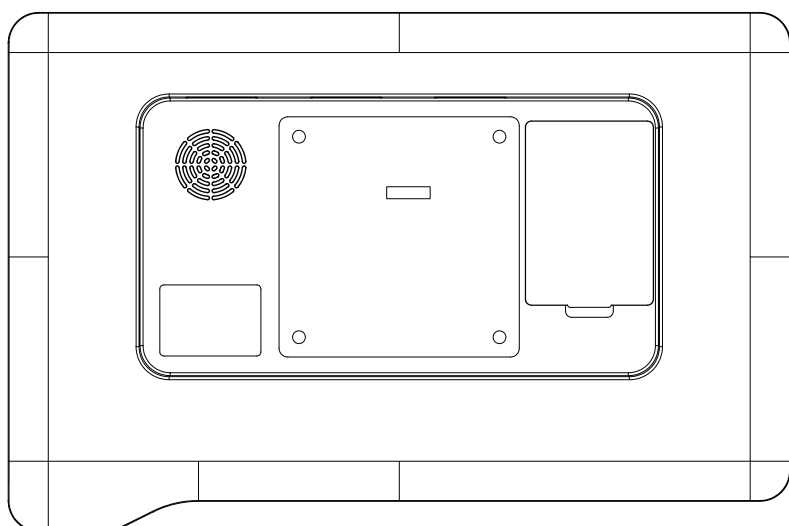

Interface

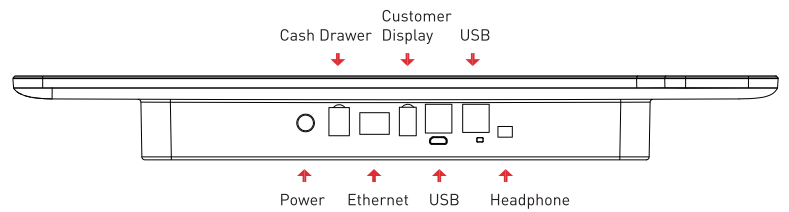

Stand

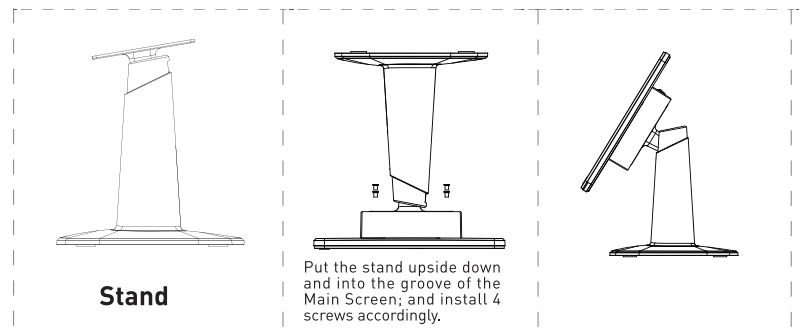

List

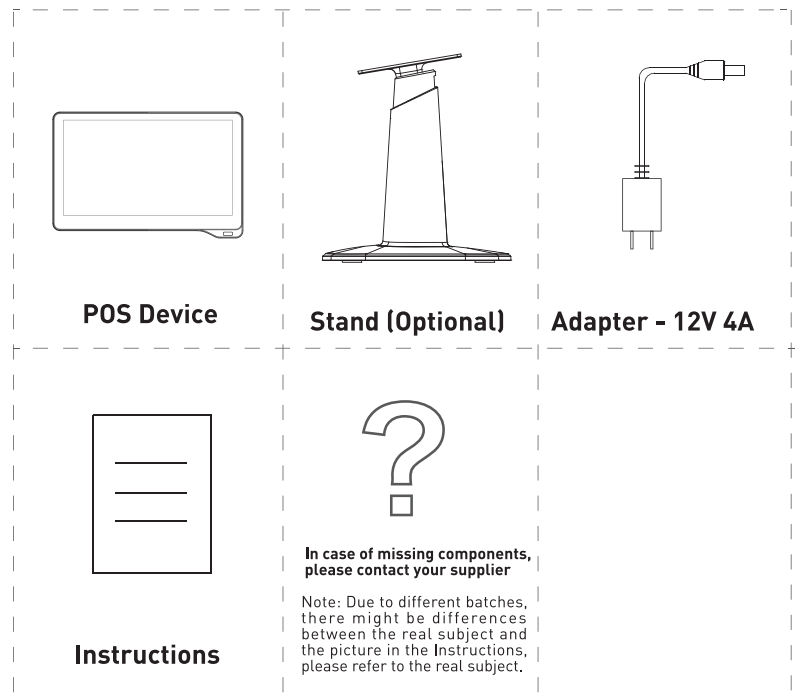

Parameters

CPU	Model	8 Core 1.5GHz
Memory	Flash ROM	8G EMMC
	RAM	2GB DDR3
WIFI		802.11 b/g/n Wifi WIFI Direct supported
Storage	15.6" Capacitive Touch Screen	HD 1920*1080
	Audio output	3.5mm Active Speaker
	USB	4 * USB 2.0
	RJ45	1 * Ethernet Interface
Power	RJ11	1 * Cash Drawer
	RJ12	1 * Customer Display
	Input	110V-240V, 50-60Hz
OS	Output	12V/3A
	Chargeable Lithium Battery (Optional)	11.1V/2200Mah
OS	ALIOS	

Warning:

This device complies with Part 15 of the FCC Rules. Operation is subject to the following two conditions: (1) this device may not cause harmful interference, and (2) this device must accept any interference received, including interference that may cause undesired operation.

changes or modifications not expressly approved by the party responsible for compliance could void the user's authority to operate the equipment.

NOTE: This equipment has been tested and found to comply with the limits for a Class B digital device, pursuant to Part 15 of the FCC Rules. These limits are designed to provide reasonable protection against harmful interference in a residential installation. This equipment generates, uses and can radiate radio frequency energy and, if not installed and used in accordance with the instructions, may cause harmful interference to radio communications. However, there is no guarantee that interference will not occur in a particular installation. If this equipment does cause harmful interference to radio or television reception, which can be determined by turning the equipment off and on, the user is encouraged to try to correct the interference by one or more of the following measures:

- Reorient or relocate the receiving antenna.
- Increase the separation between the equipment and receiver.
- Connect the equipment into an outlet on a circuit different from that to which the receiver is connected.
- Consult the dealer or an experienced radio/TV technician for help.

NOTE: This device and its antenna(s) must not be co-located or operation in conjunction with any other antenna or transmitter

RF Exposure Statement

To maintain compliance with FCC's RF Exposure guidelines, This equipment should be installed and operated with minimum distance of 20cm the radiator your body. This device and its antenna(s) must not be co-located or operation in conjunction with any other antenna or transmitter