



TEST REPORT

Report No. : **CHEW19100027** Report verification : 

Project No. : **SHT1907051103EW**

FCC ID..... : **2AT6UM4-HDFS**

Applicant's name..... : **Suzhou PeakSonic Medical Technology Co.Ltd.**

Address..... : 2A, West Side of Building G4, Kunshan Hi-Tech Medical Device Industrial Park, Qiandeng Town,Kunshan City,Suzhou City,Jiangsu Prov.

Manufacturer..... : Suzhou PeakSonic Medical Technology Co.Ltd.

Address..... : 2A, West Side of Building G4, Kunshan Hi-Tech Medical Device Industrial Park, Qiandeng Town,Kunshan City,Suzhou City,Jiangsu Prov.

Test item description : **Bladder Scanner**

Trade Mark : 

Model/Type reference..... : M4-HD

Listed Model(s) : M4,M3-HD,M3

Standard : **FCC CFR Title 47 Part 15 Subpart C Section 15.247**

Date of receipt of test sample..... : Apr.09, 2019

Date of testing..... : Apr.09, 2019- Jul.25, 2019

Date of issue..... : Oct.11, 2019

Result..... : **PASS**

Compiled by
(position+printedname+signature).... : File administrators Echo Wei 

Supervised by
(position+printedname+signature).... : Project Engineer Jerry Zhao 

Approved by
(position+printedname+signature).... : RF Manager Hans Hu 

Testing Laboratory Name : **Shenzhen Huatongwei International Inspection Co., Ltd.**

Address..... : 1/F, Bldg 3, Hongfa Hi-tech Industrial Park, Genyu Road, Tianliao, Gongming, Shenzhen, China

Shenzhen Huatongwei International Inspection Co., Ltd. All rights reserved.

This publication may be reproduced in whole or in part for non-commercial purposes as long as the Shenzhen Huatongwei International Inspection Co., Ltd. is acknowledged as copyright owner and source of the material. Shenzhen Huatongwei International Inspection Co., Ltd. takes no responsibility for and will not assume liability for damages resulting from the reader's interpretation of the reproduced material due to its placement and context.

The test report merely correspond to the test sample.

Contents

1.	<u>TEST STANDARDS AND REPORT VERSION</u>	3
1.1.	Test Standards	3
1.2.	Report version	3
2.	<u>TEST DESCRIPTION</u>	4
3.	<u>SUMMARY</u>	5
3.1.	Client Information	5
3.2.	Product Description	5
3.3.	Operation state	6
3.4.	EUT configuration	6
3.5.	Modifications	6
4.	<u>TEST ENVIRONMENT</u>	7
4.1.	Address of the test laboratory	7
4.2.	Test Facility	7
4.3.	Environmental conditions	8
4.4.	Statement of the measurement uncertainty	8
4.5.	Equipments Used during the Test	9
5.	<u>TEST CONDITIONS AND RESULTS</u>	11
5.1.	Antenna requirement	11
5.2.	Conducted Emissions (AC Main)	12
5.3.	Conducted Peak Output Power	15
5.4.	Power Spectral Density	16
5.5.	6dB bandwidth	19
5.6.	Restricted band	22
5.7.	Band edge and Spurious Emissions (conducted)	25
5.8.	Spurious Emissions (radiated)	34
6.	<u>TEST SETUP PHOTOS</u>	41
7.	<u>EXTERANAL AND INTERNAL PHOTOS</u>	43

1. TEST STANDARDS AND REPORT VERSION

1.1. Test Standards

The tests were performed according to following standards:

[FCC Rules Part 15.247](#): Frequency Hopping, Direct Spread Spectrum and Hybrid Systems that are in operation within the bands of 902-928 MHz, 2400-2483.5 MHz, and 5725-5850 MHz.

[ANSI C63.10:2013](#): American National Standard for Testing Unlicensed Wireless Devices

[KDB 558074 D01 15.247 Meas Guidance v05](#): Guidance for Compliance Measurements on Digital Transmission System, Frequency Hopping Spread Spectrum System, and Hybrid System Devices Operating under Section 15.247 of The FCC Rules

1.2. Report version

Revision No.	Date of issue	Description
N/A	2019-10-11	Only changed the Manufacturer's name and address is based on the report CHTEW19070142(2019-07-26)

2. TEST DESCRIPTION

Test Item	FCC Rule	Result	Test Engineer
Antenna requirement	15.203/15.247(c)	PASS	Jiosheng Feng
Line Conducted Emissions (AC Main)	15.207	PASS	Bruce Wong
Conducted Peak Output Power	15.247(b)(3)	PASS	Bruce Wong
Power Spectral Density	15.247(e)	PASS	Bruce Wong
6dB Bandwidth	15.247(a)(2)	PASS	Bruce Wong
Restricted band	15.247(d)/15.205	PASS	Bruce Wong
Spurious Emissions	15.247(d)/15.209	PASS	Bruce Wong

Note: The measurement uncertainty is not included in the test result.

3. SUMMARY

3.1. Client Information

Applicant:	Suzhou PeakSonic Medical Technology Co.Ltd.
Address:	2A, West Side of Building G4, Kunshan Hi-Tech Medical Device Industrial Park, Qiandeng Town,Kunshan City,Suzhou City,Jiangsu Prov.
Manufacturer:	Suzhou PeakSonic Medical Technology Co.Ltd.
Address:	2A, West Side of Building G4, Kunshan Hi-Tech Medical Device Industrial Park, Qiandeng Town,Kunshan City,Suzhou City,Jiangsu Prov.

3.2. Product Description

Name of EUT:	Bladder Scanner
Trade Mark:	-
Model No.:	M4-HD
Listed Model(s):	M4,M3-HD,M3
Power supply:	DC 8.4V
Adapter information:	INPUT: 100-240Va.c., 50/60Hz, 0.5A max OUTPUT: 8.4Vd.c., 1.5A
Hardware version:	-
Software version:	-
WIFI	
Supported type:	802.11b/802.11g
Modulation:	DSSS for 802.11b OFDM for 802.11g
Operation frequency:	2412MHz~2462MHz
Channel number:	11
Channel separation:	5MHz
Antenna type:	external antenna
Antenna gain:	3dbi

3.3. Operation state

➤ **Test frequency list**

According to section 15.31(m), regards to the operating frequency range over 10 MHz, must select three channel which were tested. the Lowest frequency, the middle frequency, and the highest frequency of channel were selected to perform the test, please see the above gray bottom.

802.11b/g	
Channel	Frequency (MHz)
01	2412
02	2417
...	...
06	2437
...	...
10	2457
11	2462

➤ **Test mode**

For RF test items
The engineering test program was provided and enabled to make EUT continuous transmit (duty cycle>98%).
For AC power line conducted emissions:
The EUT was set to connect with the WLAN AP under large package sizes transmission.
For Radiated suprious emissions test item:
The engineering test program was provided and enabled to make EUT continuous transmit(duty cycle>98%). The EUT in each of three orthogonal axis emissions had been tested ,but only the worst case (X axis) data Recorded in the report.

3.4. EUT configuration

The following peripheral devices and interface cables were connected during the measurement:

- - supplied by the manufacturer
- - supplied by the lab

○ /	Manufacturer:	/
	Model No.:	/
○ /	Manufacturer:	/
	Model No.:	/

3.5. Modifications

No modifications were implemented to meet testing criteria.

4. TEST ENVIRONMENT

4.1. Address of the test laboratory

Laboratory: Shenzhen Huatongwei International Inspection Co., Ltd.

Address: 1/F, Bldg 3, Hongfa Hi-tech Industrial Park, Genyu Road, Tianliao, Gongming, Shenzhen, China

4.2. Test Facility

CNAS-Lab Code: L1225

Shenzhen Huatongwei International Inspection Co., Ltd. has been assessed and proved to be in compliance with CNAS-CL01 Accreditation Criteria for Testing and Calibration Laboratories (identical to ISO/IEC17025: 2005 General Requirements) for the Competence of Testing and Calibration Laboratories.

A2LA-Lab Cert. No.: 3902.01

Shenzhen Huatongwei International Inspection Co., Ltd. EMC Laboratory has been accredited by A2LA for technical competence in the field of electrical testing, and proved to be in compliance with ISO/IEC 17025: 2005 General Requirements for the Competence of Testing and Calibration Laboratories and any additional program requirements in the identified field of testing.

FCC-Registration No.: 762235

Shenzhen Huatongwei International Inspection Co., Ltd. EMC Laboratory has been registered and fully described in a report filed with the FCC (Federal Communications Commission). The acceptance letter from the FCC is maintained in our files.

IC-Registration No.:5377A

Two 3m Alternate Test Site of Shenzhen Huatongwei International Inspection Co., Ltd. has been registered by Certification and Engineering Bureau of Industry Canada for the performance of radiated measurements with Registration No.: 5377A.

ACA

Shenzhen Huatongwei International Inspection Co., Ltd. EMC Laboratory can also perform testing for the Australian C-Tick mark as a result of our A2LA accreditation.

4.3. Environmental conditions

During the measurement the environmental conditions were within the listed ranges:

Temperature:	15~35°C
Relative Humidity:	30~60 %
Air Pressure:	950~1050mba

4.4. Statement of the measurement uncertainty

The data and results referenced in this document are true and accurate. The reader is cautioned that there may be errors in calibration limits of the equipment and facilities. The measurement uncertainty was calculated for all measurements listed in this test report according to TR-100028-01 "Electromagnetic compatibility and Radio spectrum Matters (ERM); Uncertainties in the measurement of mobile radio equipment characteristics; Part 1" and TR-100028-02 "Electromagnetic compatibility and Radio spectrum Matters (ERM); Uncertainties in the measurement of mobile radio equipment characteristics; Part 2" and is documented in the Shenzhen Huatongwei International Inspection Co., Ltd. quality system according to ISO/IEC 17025. Furthermore, component and process variability of devices similar to that tested may result in additional deviation. The manufacturer has the sole responsibility of continued compliance of the device.

Here after the best measurement capability for Shenzhen Huatongwei International Inspection Co., Ltd. is reported:

Test Items	Measurement Uncertainty	Notes
Transmitter power conducted	0.51 dB	(1)
Conducted spurious emissions 9kHz~40GHz	0.51 dB	(1)
Conducted Disturbance 150kHz~30MHz	3.02 dB	(1)
Radiated Emissions below 1GHz	4.90 dB	(1)
Radiated Emissions above 1GHz	4.96 dB	(1)
Occupied Bandwidth	70 Hz	(1)

(1) This uncertainty represents an expanded uncertainty expressed at approximately the 95% confidence level using a coverage factor of $k=1.96$.

4.5. Equipments Used during the Test

● Conducted Emission						
Used	Test Equipment	Manufacturer	Model No.	Serial No.	Last Cal. Date (YY-MM-DD)	Next Cal. Date (YY-MM-DD)
●	Shielded Room	Albatross projects	N/A	N/A	2018/09/28	2023/09/27
●	EMI Test Receiver	R&S	ESCI	101247	2018/10/27	2019/10/26
●	Artificial Mains	SCHWARZBECK	NNLK 8121	573	2018/10/27	2019/10/26
●	Pulse Limiter	R&S	ESH3-Z2	100499	2018/10/27	2019/10/26
●	RF Connection Cable	HUBER+SUHNER	EF400	N/A	2018/11/15	2019/11/14
●	Test Software	R&S	ES-K1	N/A	N/A	N/A
○	Single Balanced Telecom Pair ISN	FCC	FCC-TLISN-T2-02	20371	2018/10/28	2019/10/27
○	Two Balanced Telecom Pairs ISN	FCC	FCC-TLISN-T4-02	20373	2018/10/28	2019/10/27
○	Four Balanced Telecom Pairs ISN	FCC	FCC-TLISN-T8-02	20375	2018/10/28	2019/10/27
○	V-Network	R&S	ESH3-Z6	100211	2018/10/27	2019/10/26
○	V-Network	R&S	ESH3-Z6	100210	2018/10/27	2019/10/26
○	2-Line V-Network	R&S	ESH3-Z5	100049	2018/10/27	2019/10/26
● Radiated Emission-6th test site						
Used	Test Equipment	Manufacturer	Model No.	Serial No.	Last Cal. Date (YY-MM-DD)	Next Cal. Date (YY-MM-DD)
●	Semi-Anechoic Chamber	Albatross projects	SAC-3m-02	N/A	2018/09/30	2021/09/29
●	EMI Test Receiver	R&S	ESCI	100900	2018/10/28	2019/10/27
●	Loop Antenna	R&S	HFH2-Z2	100020	2017/11/20	2020/11/19
●	Ultra-Broadband Antenna	SCHWARZBECK	VULB9163	546	2017/04/05	2020/04/04
●	Pre-Amplifier	SCHWARZBECK	BBV 9742	N/A	2018/11/15	2019/11/14
●	RF Connection Cable	HUBER+SUHNER	N/A	N/A	2018/09/28	2019/09/27
●	RF Connection Cable	HUBER+SUHNER	SUCOFLEX104	501184/4	2018/09/28	2019/09/27
●	Test Software	R&S	ES-K1	N/A	N/A	N/A
●	Turntable	Maturo Germany	TT2.0-1T	N/A	N/A	N/A
●	Antenna Mast	Maturo Germany	CAM-4.0-P-12	N/A	N/A	N/A
● Radiated emission-7th test site						
Used	Test Equipment	Manufacturer	Model No.	Serial No.	Last Cal. Date (YY-MM-DD)	Next Cal. Date (YY-MM-DD)
●	Semi-Anechoic Chamber	Albatross projects	SAC-3m-01	N/A	2018/09/30	2021/09/29
●	Spectrum Analyzer	R&S	FSP40	100597	2018/10/27	2019/10/26
●	Horn Antenna	SCHWARZBECK	9120D	1011	2017/03/27	2020/03/26
●	Pre-amplifier	BONN	BLWA0160-2M	1811887	2018/11/14	2019/11/13
●	Pre-amplifier	CD	PAP-0102	12004	2018/11/14	2019/11/13
●	Broadband Pre-amplifier	SCHWARZBECK	BBV 9718	9718-248	2019/04/26	2020/04/25
●	RF Connection Cable	HUBER+SUHNER	RE-7-FH	N/A	2018/11/15	2019/11/14
●	RF Connection Cable	HUBER+SUHNER	RE-7-FL	N/A	2018/11/15	2019/11/14
●	Test Software	Audix	E3	N/A	N/A	N/A
●	Turntable	Maturo Germany	TT2.0-1T	N/A	N/A	N/A
●	Antenna Mast	Maturo Germany	CAM-4.0-P-12	N/A	N/A	N/A

● RF Conducted Method						
Used	Test Equipment	Manufacturer	Model No.	Serial No.	Last Cal. Date (YY-MM-DD)	Next Cal. Date (YY-MM-DD)
●	Signal and spectrum Analyzer	R&S	FSV40	100048	2018/10/28	2019/10/27
●	Spectrum Analyzer	Agilent	N9020A	MY50510187	2018/09/29	2019/09/28
●	OSP	R&S	OSP120	101317	N/A	N/A
○	Radio communication tester	R&S	CMW500	137688-Lv	2018/09/29	2019/09/28
○	Test software	Tonscend	JS1120-1(LTE)	N/A	N/A	N/A
○	Test software	Tonscend	JS1120-2(WIFI)	N/A	N/A	N/A
○	Test software	Tonscend	JS1120-3(WCDMA)	N/A	N/A	N/A
○	Test software	Tonscend	JS1120-4(GSM)	N/A	N/A	N/A

5. TEST CONDITIONS AND RESULTS

5.1. Antenna requirement

REQUIREMENT:

FCC CFR Title 47 Part 15 Subpart C Section 15.203:

An intentional radiator shall be designed to ensure that no antenna other than that furnished by the responsible party shall be used with the device. The use of a permanently attached antenna or of an antenna that uses a unique coupling to the intentional radiator, the manufacturer may design the unit so that a broken antenna can be replaced by the user, but the use of a standard antenna jack or electrical connector is prohibited.

FCC CFR Title 47 Part 15 Subpart C Section 15.247(c) (1)(i):

(i) Systems operating in the 2400~2483.5 MHz band that is used exclusively for fixed. Point-to-point operations may employ transmitting antennas with directional gain greater than 6 dBi provided the maximum conducted output power of the intentional radiator is reduced by 1 dB for every 3 dB that the directional gain of the antenna exceeds 6 dBi.

TEST RESULTS

Passed Not Applicable

The directional gain of the antenna less than 6 dBi, please refer to the below antenna photo.



5.2. Conducted Emissions (AC Main)

LIMIT

FCC CFR Title 47 Part 15 Subpart C Section 15.207:

Frequency range (MHz)	Limit (dBuV)	
	Quasi-peak	Average
0.15-0.5	66 to 56*	56 to 46*
0.5-5	56	46
5-30	60	50

* Decreases with the logarithm of the frequency.

TEST CONFIGURATION

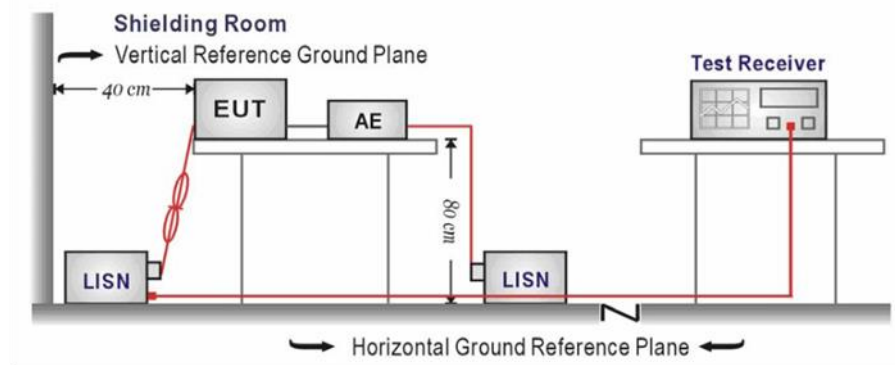

TEST PROCEDURE

1. The EUT was setup according to ANSI C63.10:2013 requirements.
2. The EUT was placed on a platform of nominal size, 1 m by 1.5 m, raised 80 cm above the conducting ground plane. The vertical conducting plane was located 40 cm to the rear of the EUT. All other surfaces of EUT were at least 80 cm from any other grounded conducting surface.
3. The EUT and simulators are connected to the main power through a line impedances stabilization network (LISN). The LISN provides a 50 ohm /50uH coupling impedance for the measuring equipment.
4. The peripheral devices are also connected to the main power through a LISN. (Please refer to the block diagram of the test setup and photographs)
5. Each current-carrying conductor of the EUT power cord, except the ground (safety) conductor, was individually connected through a LISN to the input power source.
6. The excess length of the power cord between the EUT and the LISN receptacle were folded back and forth at the center of the lead to form a bundle not exceeding 40 cm in length.
7. Conducted Emissions were investigated over the frequency range from 0.15MHz to 30MHz using a receiver bandwidth of 9 kHz.
8. During the above scans, the emissions were maximized by cable manipulation.

TEST MODE:

Please refer to the clause 3.3

TEST RESULTS

Passed Not Applicable

Note:

- 1) Transd=Cable lose+ Pulse Limiter Factor + Artificial Mains Factor
- 2) Margin= Limit -Level

Test Line:

L

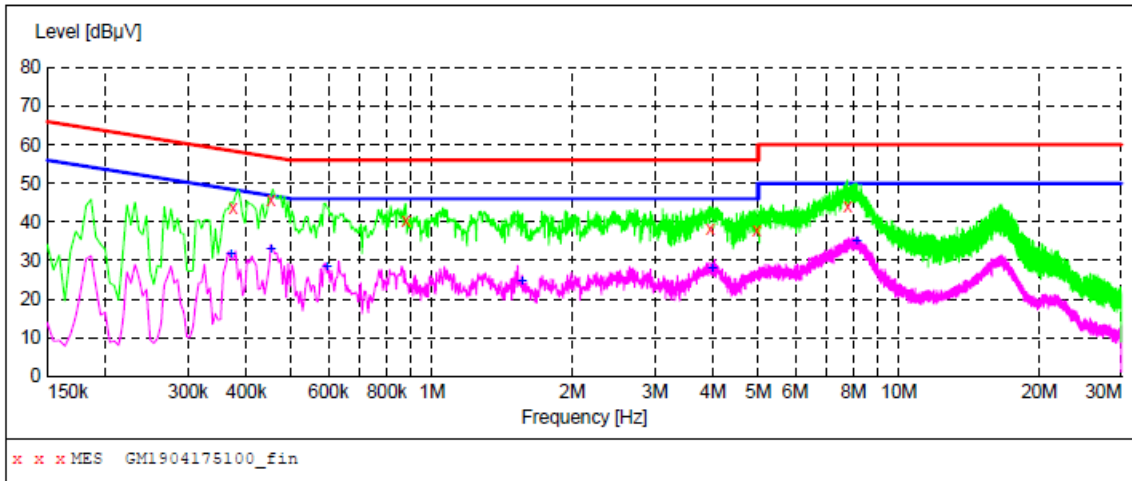

MEASUREMENT RESULT: "GM1904175100_fin"

4/17/2019 4:57PM

Frequency MHz	Level dBµV	Transd dB	Limit dBµV	Margin dB	Detector	Line	PE
0.375000	43.70	9.9	58	14.7	QP	L1	GND
0.451500	45.90	9.9	57	10.9	QP	L1	GND
0.879000	40.50	9.9	56	15.5	QP	L1	GND
3.948000	38.40	10.1	56	17.6	QP	L1	GND
4.951500	37.70	10.1	56	18.3	QP	L1	GND
7.773000	44.10	10.3	60	15.9	QP	L1	GND

MEASUREMENT RESULT: "GM1904175100_fin2"

4/17/2019 4:57PM

Frequency MHz	Level dBµV	Transd dB	Limit dBµV	Margin dB	Detector	Line	PE
0.370500	31.50	9.9	49	17.0	AV	L1	GND
0.451500	32.70	9.9	47	14.1	AV	L1	GND
0.595500	28.20	9.9	46	17.8	AV	L1	GND
1.558500	24.40	10.0	46	21.6	AV	L1	GND
3.988500	27.80	10.1	46	18.2	AV	L1	GND
8.133000	34.80	10.3	50	15.2	AV	L1	GND

Test Line:

N

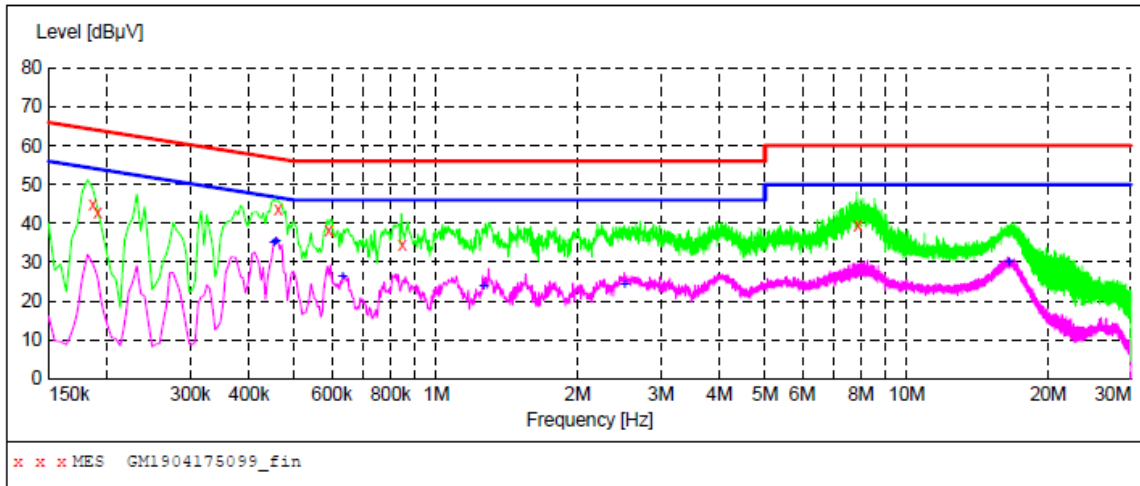

MEASUREMENT RESULT: "GM1904175099_fin"

4/17/2019 4:54PM

Frequency MHz	Level dBµV	Transd dB	Limit dBµV	Margin dB	Detector	Line	PE
0.186000	45.00	9.9	64	19.2	QP	N	GND
0.190500	43.00	9.9	64	21.0	QP	N	GND
0.460500	43.70	9.9	57	13.0	QP	N	GND
0.591000	38.10	9.9	56	17.9	QP	N	GND
0.847500	34.60	9.9	56	21.4	QP	N	GND
7.867500	39.50	10.3	60	20.5	QP	N	GND

MEASUREMENT RESULT: "GM1904175099_fin2"

4/17/2019 4:54PM

Frequency MHz	Level dBµV	Transd dB	Limit dBµV	Margin dB	Detector	Line	PE
0.451500	35.00	9.9	47	11.8	AV	N	GND
0.456000	35.30	9.9	47	11.5	AV	N	GND
0.631500	26.30	9.9	46	19.7	AV	N	GND
1.261500	23.70	10.0	46	22.3	AV	N	GND
2.517000	24.00	10.0	46	22.0	AV	N	GND
16.471500	30.00	10.5	50	20.0	AV	N	GND

5.3. Conducted Peak Output Power

LIMIT

FCC CFR Title 47 Part 15 Subpart C Section 15.247 (b)(3): 30dBm

TEST CONFIGURATION

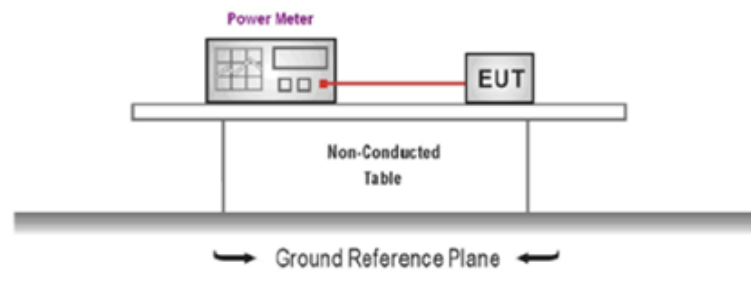

TEST PROCEDURE

1. The EUT was tested according to ANSI C63.10: 2013 and KDB 558074 D01 for compliance to FCC 47 CFR 15.247 requirements.
2. The maximum peak conducted output power may be measured using a broadband peak RF power meter.
3. The power meter shall have a video bandwidth that is greater than or equal to the DTS bandwidth and shall utilize a fast-responding diode detector
4. Record the measurement data.

TEST MODE:

Please refer to the clause 3.3

TEST RESULTS

Passed Not Applicable

Type	Channel	Peak Output power (dBm)	Limit (dBm)	Result
802.11b	01	8.67	≤30.00	Pass
	06	9.57		
	11	9.38		
802.11g	01	8.45	≤30.00	Pass
	06	8.39		
	11	8.13		

5.4. Power Spectral Density

LIMIT

FCC CFR Title 47 Part 15 Subpart C Section 15.247 (e):

For digitally modulated systems, the power spectral density conducted from the intentional radiator to the antenna shall not be greater than 8 dBm in any 3 kHz band during any time interval of continuous transmission.

TEST CONFIGURATION

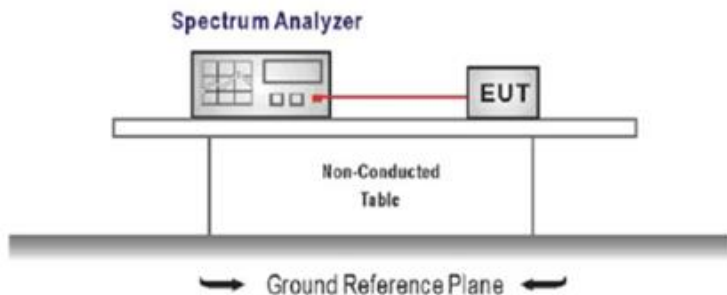

TEST PROCEDURE

1. Connect the antenna port(s) to the spectrum analyzer input,
2. Configure the spectrum analyzer as shown below:
 Center frequency=DTS channel center frequency
 Span =1.5 times the DTS bandwidth
 RBW = 3 kHz ≤ RBW ≤ 100 kHz, VBW ≥ 3 × RBW
 Sweep time = auto couple
 Detector = peak
 Trace mode = max hold
3. Place the radio in continuous transmit mode, allow the trace to stabilize, view the transmitter wave form on the spectrum analyzer.
4. Use the peak marker function to determine the maximum amplitude level within the RBW.
5. If measured value exceeds limit, reduce RBW (no less than 3 kHz) and repeat.

TEST MODE:

Please refer to the clause 3.3

TEST RESULTS

Passed Not Applicable

Type	Channel	Power Spectral Density (dBm/30KHz)	Limit (dBm/3KHz)	Result
802.11b	01	-1.31	≤8.00	Pass
	06	-0.35		
	11	-0.65		
802.11g	01	-3.87	≤8.00	Pass
	06	-3.21		
	11	-2.77		

Test plot as follows:

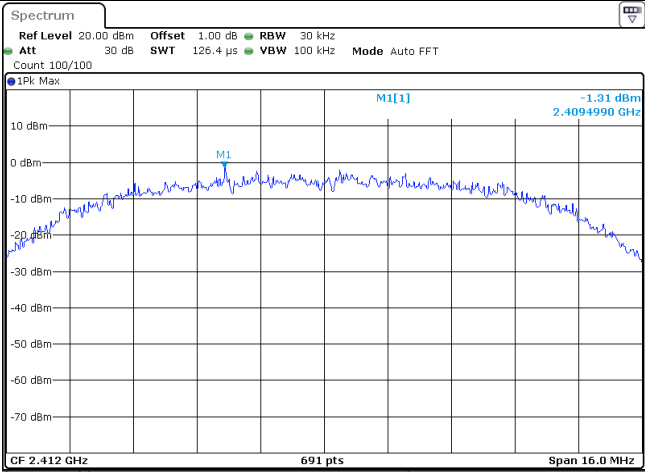
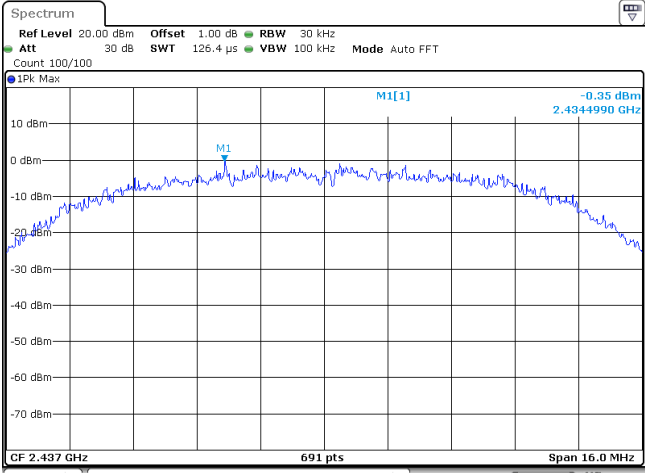
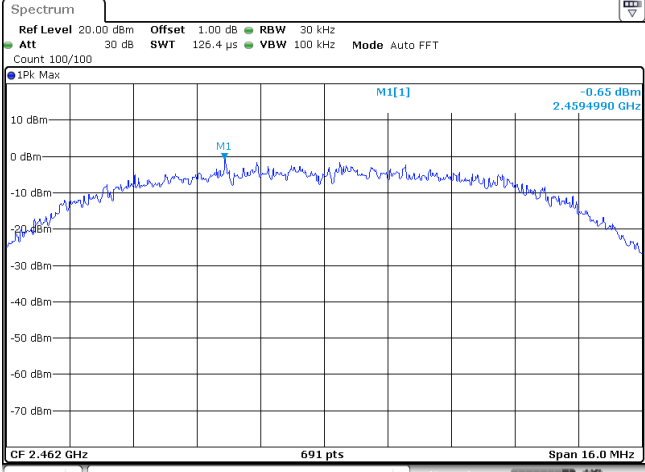
Type:		802.11 b
CH01	 <p>Spectrum</p> <p>Ref Level 20.00 dBm Offset 1.00 dB RBW 30 kHz Att 30 dB SWT 126.4 μs VBW 100 kHz Mode Auto FFT Count 100/100</p> <p>IPK Max</p> <p>M1[1] -1.31 dBm 2.4094990 GHz</p> <p>CF 2.412 GHz 691 pts Span 16.0 MHz</p> <p>Date: 23 JUL 2019 13:54:00</p>	
CH06	 <p>Spectrum</p> <p>Ref Level 20.00 dBm Offset 1.00 dB RBW 30 kHz Att 30 dB SWT 126.4 μs VBW 100 kHz Mode Auto FFT Count 100/100</p> <p>IPK Max</p> <p>M1[1] -0.35 dBm 2.4344990 GHz</p> <p>CF 2.437 GHz 691 pts Span 16.0 MHz</p> <p>Date: 23 JUL 2019 13:57:06</p>	
CH11	 <p>Spectrum</p> <p>Ref Level 20.00 dBm Offset 1.00 dB RBW 30 kHz Att 30 dB SWT 126.4 μs VBW 100 kHz Mode Auto FFT Count 100/100</p> <p>IPK Max</p> <p>M1[1] -0.65 dBm 2.4594990 GHz</p> <p>CF 2.462 GHz 691 pts Span 16.0 MHz</p> <p>Date: 23 JUL 2019 13:58:06</p>	

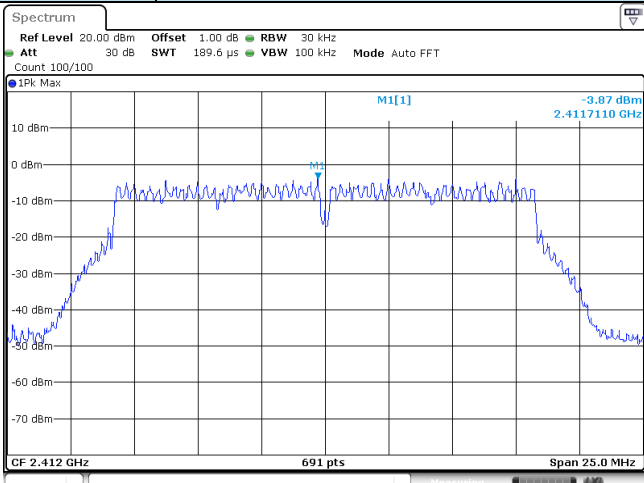
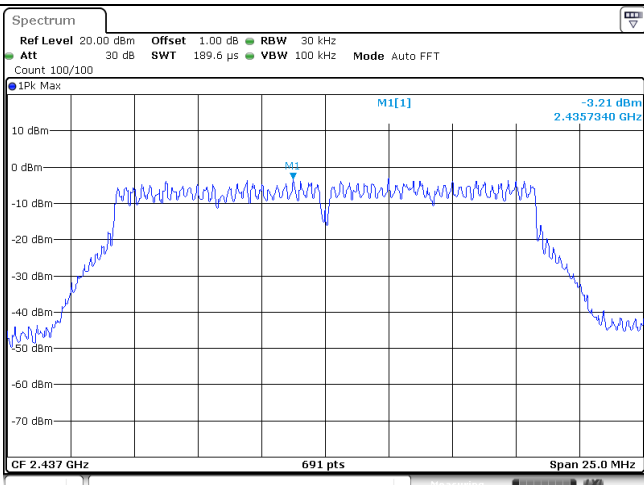
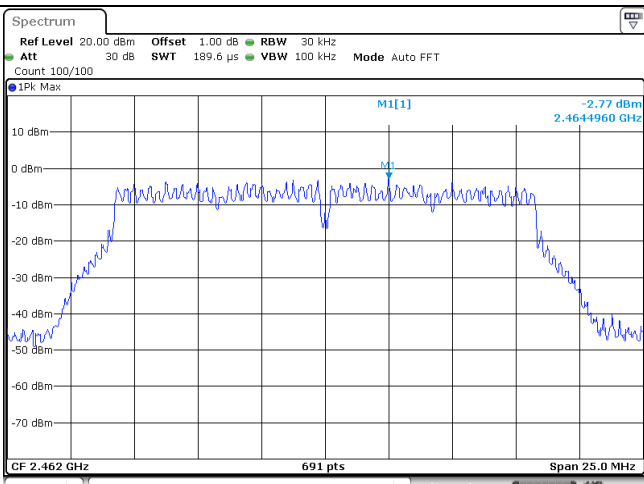
Type:		802.11 g
CH01	 <p>Spectrum plot for CH01. The plot shows a signal at 2.4117110 GHz with a power level of -3.87 dBm. The plot includes parameters: Ref Level 20.00 dBm, Att 30 dB, Offset 1.00 dB, RBW 30 kHz, SWT 189.6 μs, VBW 100 kHz, Mode Auto FFT, Count 100/100, IPK Max, CF 2.412 GHz, 691 pts, Span 25.0 MHz.</p>	
CH06	 <p>Spectrum plot for CH06. The plot shows a signal at 2.4357340 GHz with a power level of -3.21 dBm. The plot includes parameters: Ref Level 20.00 dBm, Att 30 dB, Offset 1.00 dB, RBW 30 kHz, SWT 189.6 μs, VBW 100 kHz, Mode Auto FFT, Count 100/100, IPK Max, CF 2.437 GHz, 691 pts, Span 25.0 MHz.</p>	
CH11	 <p>Spectrum plot for CH11. The plot shows a signal at 2.4644960 GHz with a power level of -2.77 dBm. The plot includes parameters: Ref Level 20.00 dBm, Att 30 dB, Offset 1.00 dB, RBW 30 kHz, SWT 189.6 μs, VBW 100 kHz, Mode Auto FFT, Count 100/100, IPK Max, CF 2.462 GHz, 691 pts, Span 25.0 MHz.</p>	

5.5. 6dB bandwidth

LIMIT

FCC CFR Title 47 Part 15 Subpart C Section 15.247 (a)(2):

For digital modulation systems, the minimum 6 dB bandwidth shall be at least 500 kHz.

TEST CONFIGURATION

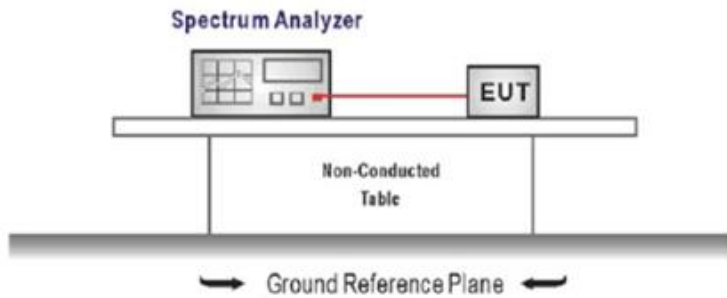

TEST PROCEDURE

1. Connect the antenna port(s) to the spectrum analyzer input.
2. Configure the spectrum analyzer as shown below (enter all losses between the transmitter output and the spectrum analyzer).
 Center Frequency = DTS channel center frequency
 Span = 2 x DTS bandwidth
 RBW = 100 kHz, VBW ≥ 3 x RBW
 Sweep time = auto couple
 Detector = Peak
 Trace mode = max hold
3. Place the radio in continuous transmit mode, allow the trace to stabilize, view the transmitter wave form on the spectrum analyzer.
4. Measure the maximum width of the emission that is constrained by the frequencies associated with the two outermost amplitude points (upper and lower frequencies) that are attenuated by 6 dB relative to the maximum level measured in the fundamental emission, and record the pertinent measurements.

TEST MODE:

Please refer to the clause 3.3

TEST RESULTS

Passed Not Applicable

Type	Channel	6dB Bandwidth (MHz)	Limit (kHz)	Result
802.11b	01	9.87	≥500	Pass
	06	9.33		
	11	9.99		
802.11g	01	16.53	≥500	Pass
	06	16.53		
	11	16.47		

Test plot as follows:

Type:		802.11 b																												
CH01	<p>Spectrum Ref Level 20.50 dBm Offset 1.00 dB RBW 100 kHz Att 30 dB SWT 75.9 μs VBW 300 kHz Mode Auto FFT Count 500/500 IPK View</p> <p>10 dBm 0 dBm -10 dBm -20 dBm -30 dBm -40 dBm -50 dBm -60 dBm -70 dBm</p> <p>CF 2.412 GHz 1001 pts Span 30.0 MHz</p> <table border="1"> <thead> <tr> <th>Types</th> <th>Ref</th> <th>Trc</th> <th>X-value</th> <th>Y-value</th> <th>Function</th> <th>Function Result</th> </tr> </thead> <tbody> <tr> <td>M1</td> <td>1</td> <td></td> <td>2.40714 GHz</td> <td>-3.73 dBm</td> <td></td> <td></td> </tr> <tr> <td>M2</td> <td>1</td> <td></td> <td>2.40954 GHz</td> <td>3.02 dBm</td> <td></td> <td></td> </tr> <tr> <td>D3</td> <td>M1</td> <td>1</td> <td>9.87 MHz</td> <td>0.12 dB</td> <td></td> <td></td> </tr> </tbody> </table> <p>Date: 23_JUL_2019 13:53:47</p>		Types	Ref	Trc	X-value	Y-value	Function	Function Result	M1	1		2.40714 GHz	-3.73 dBm			M2	1		2.40954 GHz	3.02 dBm			D3	M1	1	9.87 MHz	0.12 dB		
Types	Ref	Trc	X-value	Y-value	Function	Function Result																								
M1	1		2.40714 GHz	-3.73 dBm																										
M2	1		2.40954 GHz	3.02 dBm																										
D3	M1	1	9.87 MHz	0.12 dB																										
CH06	<p>Spectrum Ref Level 20.50 dBm Offset 1.00 dB RBW 100 kHz Att 30 dB SWT 75.9 μs VBW 300 kHz Mode Auto FFT Count 500/500 IPK View</p> <p>10 dBm 0 dBm -10 dBm -20 dBm -30 dBm -40 dBm -50 dBm -60 dBm -70 dBm</p> <p>CF 2.437 GHz 1001 pts Span 30.0 MHz</p> <table border="1"> <thead> <tr> <th>Types</th> <th>Ref</th> <th>Trc</th> <th>X-value</th> <th>Y-value</th> <th>Function</th> <th>Function Result</th> </tr> </thead> <tbody> <tr> <td>M1</td> <td>1</td> <td></td> <td>2.43256 GHz</td> <td>-2.24 dBm</td> <td></td> <td></td> </tr> <tr> <td>M2</td> <td>1</td> <td></td> <td>2.43451 GHz</td> <td>4.02 dBm</td> <td></td> <td></td> </tr> <tr> <td>D3</td> <td>M1</td> <td>1</td> <td>9.33 MHz</td> <td>-0.56 dB</td> <td></td> <td></td> </tr> </tbody> </table> <p>Date: 23_JUL_2019 13:56:53</p>		Types	Ref	Trc	X-value	Y-value	Function	Function Result	M1	1		2.43256 GHz	-2.24 dBm			M2	1		2.43451 GHz	4.02 dBm			D3	M1	1	9.33 MHz	-0.56 dB		
Types	Ref	Trc	X-value	Y-value	Function	Function Result																								
M1	1		2.43256 GHz	-2.24 dBm																										
M2	1		2.43451 GHz	4.02 dBm																										
D3	M1	1	9.33 MHz	-0.56 dB																										
CH11	<p>Spectrum Ref Level 20.50 dBm Offset 1.00 dB RBW 100 kHz Att 30 dB SWT 75.9 μs VBW 300 kHz Mode Auto FFT Count 500/500 IPK View</p> <p>10 dBm 0 dBm -10 dBm -20 dBm -30 dBm -40 dBm -50 dBm -60 dBm -70 dBm</p> <p>CF 2.462 GHz 1001 pts Span 30.0 MHz</p> <table border="1"> <thead> <tr> <th>Types</th> <th>Ref</th> <th>Trc</th> <th>X-value</th> <th>Y-value</th> <th>Function</th> <th>Function Result</th> </tr> </thead> <tbody> <tr> <td>M1</td> <td>1</td> <td></td> <td>2.45693 GHz</td> <td>-2.80 dBm</td> <td></td> <td></td> </tr> <tr> <td>M2</td> <td>1</td> <td></td> <td>2.45954 GHz</td> <td>3.88 dBm</td> <td></td> <td></td> </tr> <tr> <td>D3</td> <td>M1</td> <td>1</td> <td>9.99 MHz</td> <td>-1.05 dB</td> <td></td> <td></td> </tr> </tbody> </table> <p>Date: 23_JUL_2019 13:58:03</p>		Types	Ref	Trc	X-value	Y-value	Function	Function Result	M1	1		2.45693 GHz	-2.80 dBm			M2	1		2.45954 GHz	3.88 dBm			D3	M1	1	9.99 MHz	-1.05 dB		
Types	Ref	Trc	X-value	Y-value	Function	Function Result																								
M1	1		2.45693 GHz	-2.80 dBm																										
M2	1		2.45954 GHz	3.88 dBm																										
D3	M1	1	9.99 MHz	-1.05 dB																										

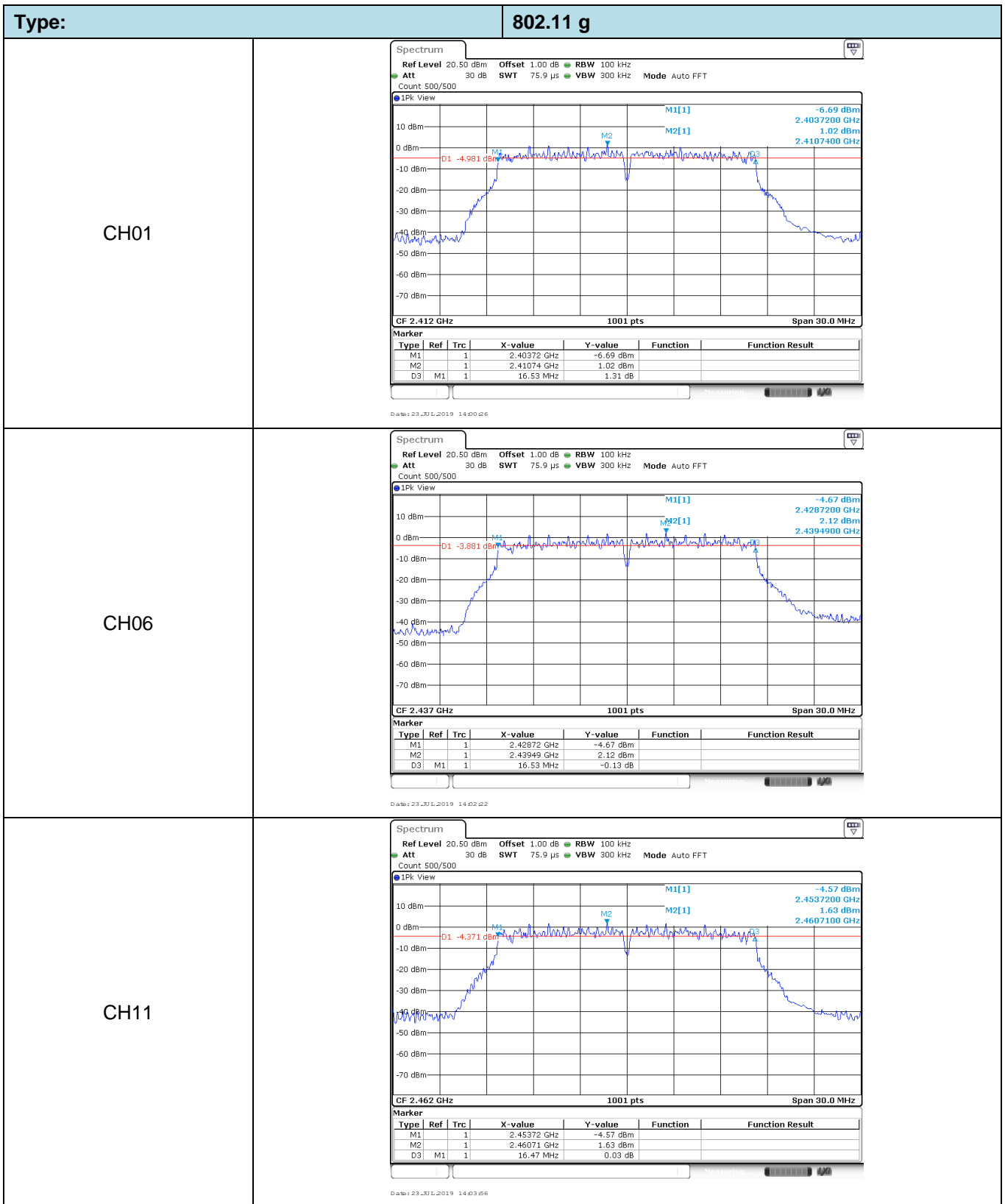

5.6. Restricted band

LIMIT

FCC CFR Title 47 Part 15 Subpart C Section 15.247 (d):

In any 100 kHz bandwidth outside the frequency band in which the spread spectrum or digitally modulated intentional radiator is operating, Radiated Emissions which fall in the restricted bands, as defined in §15.205(a), must also comply with the Radiated Emissions limits specified in §15.209(a) (see §15.205(c)).

TEST CONFIGURATION

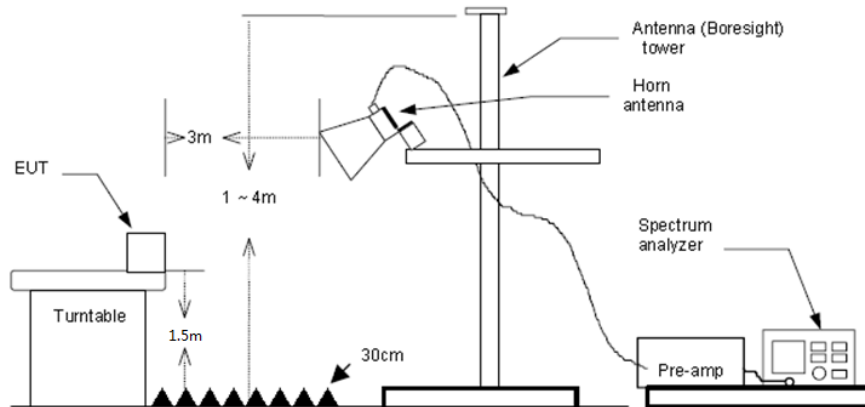

TEST PROCEDURE

- 1) The EUT was setup and tested according to ANSI C63.10:2013 for compliance to FCC 47CFR 15.247 requirements.
- 2) The EUT is placed on a turn table which is 1.5 meter above ground. The turn table is rotated 360 degrees to determine the position of the maximum emission level.
- 3) The EUT was positioned such that the distance from antenna to the EUT was 3 meters.
- 4) The antenna is scanned from 1 meter to 4 meters to find out the maximum emission level. This is repeated for both horizontal and vertical polarization of the antenna. In order to find the maximum emission, all of the interface cables were manipulated according to ANSI C63.10:2013 on radiated measurement.
- 5) The receiver set as follow:
 RBW=1MHz, VBW=3MHz PEAK detector for Peak value.
 RBW=1MHz, VBW=3MHz RMS detector for Average value.

TEST MODE:

Please refer to the clause 3.3

TEST RESULTS

Passed Not Applicable

Note:

- 1) Final level= Read level + Antenna Factor+ Cable Loss- Preamp Factor

802.11b	CH01
---------	------

Suspected Data List								
NO.	Freq. [MHz]	Reading [dB μ V/m]	Factor [dB]	Level [dB μ V/m]	Limit [dB μ V/m]	Margin [dB]	Polarity	Detector
1	2310.000	14.56	35.78	50.34	74.00	23.66	Horizontal	PK
2	2310.000	14.45	35.78	50.23	54.00	3.77	Horizontal	AV
3	2390.009	13.24	35.50	48.74	74.00	25.26	Horizontal	PK
4	2390.009	12.49	35.50	47.99	54.00	6.01	Horizontal	AV

Suspected Data List								
NO.	Freq. [MHz]	Reading [dB μ V/m]	Factor [dB]	Level [dB μ V/m]	Limit [dB μ V/m]	Margin [dB]	Polarity	Detector
1	2310.000	14.47	35.78	50.25	74.00	23.75	Vertical	PK
2	2310.000	13.91	35.78	49.69	54.00	4.31	Vertical	AV
3	2390.009	17.59	35.50	53.09	74.00	20.91	Vertical	PK
4	2390.009	16.45	35.50	51.95	54.00	2.05	Vertical	AV

802.11b	CH11
---------	------

Suspected Data List								
NO.	Freq. [MHz]	Reading [dB μ V/m]	Factor [dB]	Level [dB μ V/m]	Limit [dB μ V/m]	Margin [dB]	Polarity	Detector
1	2483.504	16.07	35.31	51.38	74.00	22.62	Horizontal	PK
2	2483.504	15.58	35.31	50.89	54.00	3.11	Horizontal	AV
3	2500.000	13.87	35.28	49.15	54.00	4.85	Horizontal	AV
4	2500.000	14.93	35.28	50.21	74.00	23.79	Horizontal	PK

Suspected Data List								
NO.	Freq. [MHz]	Reading [dB μ V/m]	Factor [dB]	Level [dB μ V/m]	Limit [dB μ V/m]	Margin [dB]	Polarity	Detector
1	2483.504	15.77	35.31	51.08	74.00	22.92	Vertical	PK
2	2483.504	15.40	35.31	50.71	54.00	3.29	Vertical	AV
3	2500.000	15.45	35.28	50.73	74.00	23.27	Vertical	PK
4	2500.000	14.82	35.28	50.10	54.00	3.90	Vertical	AV

802.11g	CH01
---------	------

Suspected Data List								
NO.	Freq. [MHz]	Reading [dB μ V/m]	Factor [dB]	Level [dB μ V/m]	Limit [dB μ V/m]	Margin [dB]	Polarity	Detector
1	2310.000	14.97	35.78	50.75	74.00	23.25	Horizontal	PK
2	2310.000	13.96	35.78	49.74	54.00	4.26	Horizontal	AV
3	2390.009	15.05	35.50	50.55	74.00	23.45	Horizontal	PK
4	2390.009	14.74	35.50	50.24	54.00	3.76	Horizontal	AV

Suspected Data List								
NO.	Freq. [MHz]	Reading [dB μ V/m]	Factor [dB]	Level [dB μ V/m]	Limit [dB μ V/m]	Margin [dB]	Polarity	Detector
1	2310.000	16.38	35.78	52.16	74.00	21.84	Vertical	PK
2	2310.000	15.69	35.78	51.47	54.00	2.53	Vertical	AV
3	2390.009	14.63	35.50	50.13	54.00	3.87	Vertical	AV
4	2390.009	15.81	35.50	51.31	74.00	22.69	Vertical	PK

802.11g	CH11
---------	------

Suspected Data List								
NO.	Freq. [MHz]	Reading [dB μ V/m]	Factor [dB]	Level [dB μ V/m]	Limit [dB μ V/m]	Margin [dB]	Polarity	Detector
1	2483.504	14.71	35.31	50.02	74.00	23.98	Horizontal	PK
2	2483.504	14.55	35.31	49.86	54.00	4.14	Horizontal	AV
3	2500.000	15.32	35.28	50.60	74.00	23.40	Horizontal	PK
4	2500.000	12.87	35.28	48.15	54.00	5.85	Horizontal	AV

Suspected Data List								
NO.	Freq. [MHz]	Reading [dB μ V/m]	Factor [dB]	Level [dB μ V/m]	Limit [dB μ V/m]	Margin [dB]	Polarity	Detector
1	2483.504	13.24	35.31	48.55	74.00	25.45	Vertical	PK
2	2483.504	12.29	35.31	47.60	54.00	6.40	Vertical	AV
3	2500.000	11.84	35.28	47.12	54.00	6.88	Vertical	AV
4	2500.000	13.45	35.28	48.73	74.00	25.27	Vertical	PK

5.7. Band edge and Spurious Emissions (conducted)

LIMIT

FCC CFR Title 47 Part 15 Subpart C Section 15.247 (d):

In any 100 kHz bandwidth outside the frequency band in which the spread spectrum intentional radiator is operating, the radio frequency power that is produced by the intentional radiator shall be at least 20 dB below that in the 100 kHz bandwidth within the band that contains the highest level of the desired power, based on either an RF conducted or a radiated measurement.

TEST CONFIGURATION

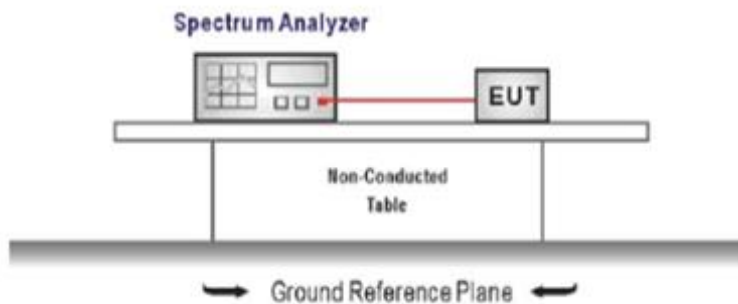

TEST PROCEDURE

1. Connect the antenna port(s) to the spectrum analyzer input.
2. Establish a reference level by using the following procedure
Center frequency=DTS channel center frequency
The span = 1.5 times the DTS bandwidth.
RBW = 100 kHz, VBW \geq 3 x RBW
Detector = peak, Sweep time = auto couple, Trace mode = max hold
Allow trace to fully stabilize
Use the peak marker function to determine the maximum PSD level

Note: the channel found to contain the maximum PSD level can be used to establish the reference level.

3. Emission level measurement
Set the center frequency and span to encompass frequency range to be measured
RBW = 100 kHz, VBW \geq 3 x RBW
Detector = peak, Sweep time = auto couple, Trace mode = max hold
Allow trace to fully stabilize
Use the peak marker function to determine the maximum amplitude level.
4. Place the radio in continuous transmit mode, allow the trace to stabilize, view the transmitter waveform on the spectrum analyzer.
5. Ensure that the amplitude of all unwanted emission outside of the authorized frequency band excluding restricted frequency bands) are attenuated by at least the minimum requirements specified (at least 20 dB relative to the maximum in-band peak PSD level in 100 kHz). Report the three highest emission relative to the limit.

TEST MODE:

Please refer to the clause 3.3

TEST RESULTS

Passed Not Applicable

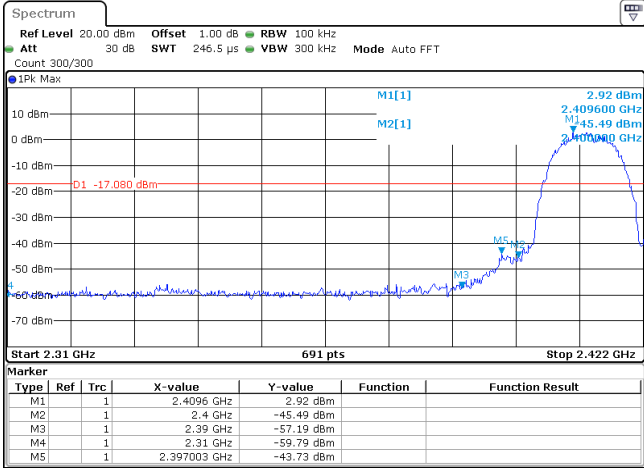
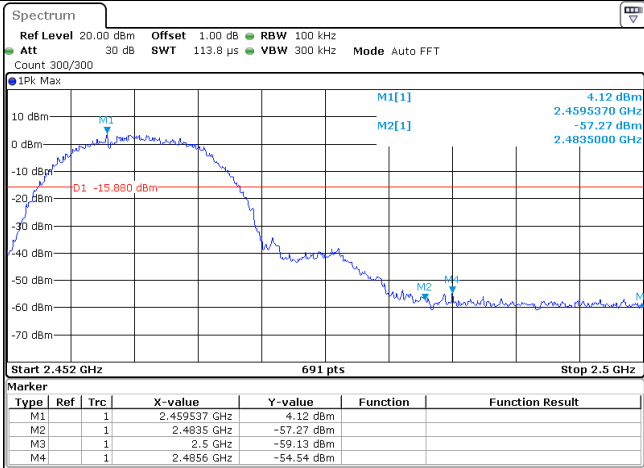
Test Item:	Bandedge	Type:	802.11 b																																										
CH01	 <p>Marker Table for CH01:</p> <table border="1"> <thead> <tr> <th>Type</th> <th>Ref</th> <th>Trc</th> <th>X-value</th> <th>Y-value</th> <th>Function</th> <th>Function Result</th> </tr> </thead> <tbody> <tr> <td>M1</td> <td>1</td> <td></td> <td>2.4096 GHz</td> <td>2.92 dBm</td> <td></td> <td></td> </tr> <tr> <td>M2</td> <td>1</td> <td></td> <td>2.4 GHz</td> <td>-45.49 dBm</td> <td></td> <td></td> </tr> <tr> <td>M3</td> <td>1</td> <td></td> <td>2.39 GHz</td> <td>-57.19 dBm</td> <td></td> <td></td> </tr> <tr> <td>M4</td> <td>1</td> <td></td> <td>2.31 GHz</td> <td>-59.79 dBm</td> <td></td> <td></td> </tr> <tr> <td>M5</td> <td>1</td> <td></td> <td>2.397003 GHz</td> <td>-43.73 dBm</td> <td></td> <td></td> </tr> </tbody> </table>			Type	Ref	Trc	X-value	Y-value	Function	Function Result	M1	1		2.4096 GHz	2.92 dBm			M2	1		2.4 GHz	-45.49 dBm			M3	1		2.39 GHz	-57.19 dBm			M4	1		2.31 GHz	-59.79 dBm			M5	1		2.397003 GHz	-43.73 dBm		
Type	Ref	Trc	X-value	Y-value	Function	Function Result																																							
M1	1		2.4096 GHz	2.92 dBm																																									
M2	1		2.4 GHz	-45.49 dBm																																									
M3	1		2.39 GHz	-57.19 dBm																																									
M4	1		2.31 GHz	-59.79 dBm																																									
M5	1		2.397003 GHz	-43.73 dBm																																									
CH11	 <p>Marker Table for CH11:</p> <table border="1"> <thead> <tr> <th>Type</th> <th>Ref</th> <th>Trc</th> <th>X-value</th> <th>Y-value</th> <th>Function</th> <th>Function Result</th> </tr> </thead> <tbody> <tr> <td>M1</td> <td>1</td> <td></td> <td>2.459537 GHz</td> <td>4.12 dBm</td> <td></td> <td></td> </tr> <tr> <td>M2</td> <td>1</td> <td></td> <td>2.4835 GHz</td> <td>-57.27 dBm</td> <td></td> <td></td> </tr> <tr> <td>M3</td> <td>1</td> <td></td> <td>2.5 GHz</td> <td>-59.13 dBm</td> <td></td> <td></td> </tr> <tr> <td>M4</td> <td>1</td> <td></td> <td>2.4856 GHz</td> <td>-54.54 dBm</td> <td></td> <td></td> </tr> </tbody> </table>			Type	Ref	Trc	X-value	Y-value	Function	Function Result	M1	1		2.459537 GHz	4.12 dBm			M2	1		2.4835 GHz	-57.27 dBm			M3	1		2.5 GHz	-59.13 dBm			M4	1		2.4856 GHz	-54.54 dBm									
Type	Ref	Trc	X-value	Y-value	Function	Function Result																																							
M1	1		2.459537 GHz	4.12 dBm																																									
M2	1		2.4835 GHz	-57.27 dBm																																									
M3	1		2.5 GHz	-59.13 dBm																																									
M4	1		2.4856 GHz	-54.54 dBm																																									

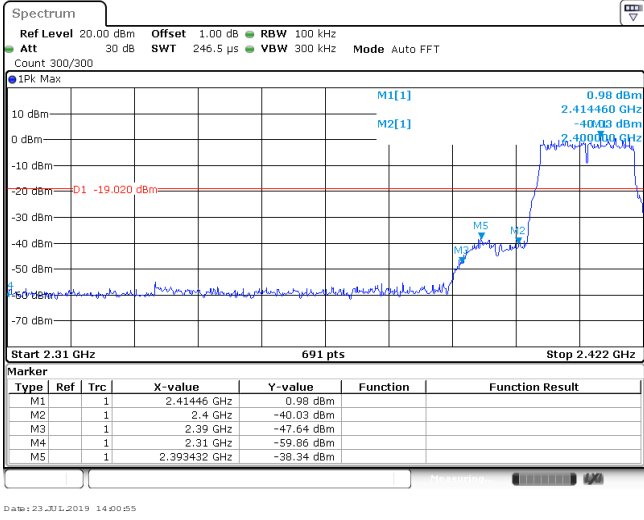
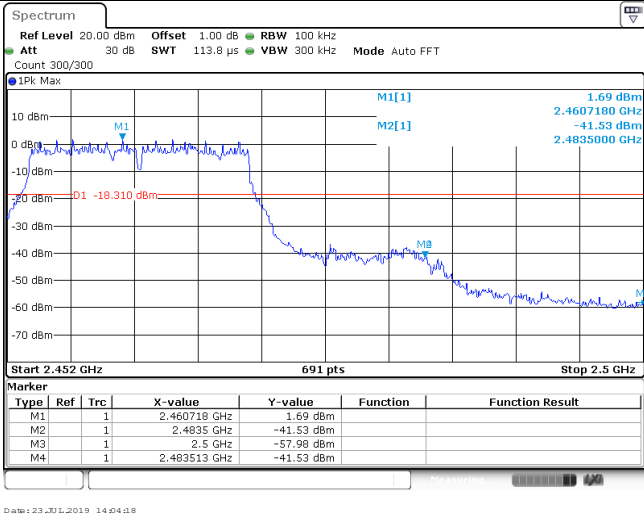
Test Item:	Bandedge	Type:	802.11 g																																																
CH01	 <p>Spectrum Ref Level 20.00 dBm Offset 1.00 dB RBW 100 kHz Att 30 dB SWT 246.5 μs VBW 300 kHz Mode Auto FFT Count 300/300 IPK Max</p> <p>Start 2.31 GHz 691 pts Stop 2.422 GHz</p> <table border="1"> <thead> <tr> <th>Marker</th> <th>Type</th> <th>Ref</th> <th>Trc</th> <th>X-value</th> <th>Y-value</th> <th>Function</th> <th>Function Result</th> </tr> </thead> <tbody> <tr> <td>M1</td> <td>1</td> <td></td> <td></td> <td>2.41446 GHz</td> <td>0.98 dBm</td> <td></td> <td></td> </tr> <tr> <td>M2</td> <td>1</td> <td></td> <td></td> <td>2.4 GHz</td> <td>-40.03 dBm</td> <td></td> <td></td> </tr> <tr> <td>M3</td> <td>1</td> <td></td> <td></td> <td>2.39 GHz</td> <td>-47.64 dBm</td> <td></td> <td></td> </tr> <tr> <td>M4</td> <td>1</td> <td></td> <td></td> <td>2.31 GHz</td> <td>-59.86 dBm</td> <td></td> <td></td> </tr> <tr> <td>M5</td> <td>1</td> <td></td> <td></td> <td>2.393432 GHz</td> <td>-38.34 dBm</td> <td></td> <td></td> </tr> </tbody> </table> <p>Date: 23 JUL 2019 14:00:55</p>			Marker	Type	Ref	Trc	X-value	Y-value	Function	Function Result	M1	1			2.41446 GHz	0.98 dBm			M2	1			2.4 GHz	-40.03 dBm			M3	1			2.39 GHz	-47.64 dBm			M4	1			2.31 GHz	-59.86 dBm			M5	1			2.393432 GHz	-38.34 dBm		
Marker	Type	Ref	Trc	X-value	Y-value	Function	Function Result																																												
M1	1			2.41446 GHz	0.98 dBm																																														
M2	1			2.4 GHz	-40.03 dBm																																														
M3	1			2.39 GHz	-47.64 dBm																																														
M4	1			2.31 GHz	-59.86 dBm																																														
M5	1			2.393432 GHz	-38.34 dBm																																														
CH11	 <p>Spectrum Ref Level 20.00 dBm Offset 1.00 dB RBW 100 kHz Att 30 dB SWT 113.8 μs VBW 300 kHz Mode Auto FFT Count 300/300 IPK Max</p> <p>Start 2.452 GHz 691 pts Stop 2.5 GHz</p> <table border="1"> <thead> <tr> <th>Marker</th> <th>Type</th> <th>Ref</th> <th>Trc</th> <th>X-value</th> <th>Y-value</th> <th>Function</th> <th>Function Result</th> </tr> </thead> <tbody> <tr> <td>M1</td> <td>1</td> <td></td> <td></td> <td>2.460718 GHz</td> <td>1.69 dBm</td> <td></td> <td></td> </tr> <tr> <td>M2</td> <td>1</td> <td></td> <td></td> <td>2.4635 GHz</td> <td>-41.53 dBm</td> <td></td> <td></td> </tr> <tr> <td>M3</td> <td>1</td> <td></td> <td></td> <td>2.5 GHz</td> <td>-57.98 dBm</td> <td></td> <td></td> </tr> <tr> <td>M4</td> <td>1</td> <td></td> <td></td> <td>2.483513 GHz</td> <td>-41.53 dBm</td> <td></td> <td></td> </tr> </tbody> </table> <p>Date: 23 JUL 2019 14:04:18</p>			Marker	Type	Ref	Trc	X-value	Y-value	Function	Function Result	M1	1			2.460718 GHz	1.69 dBm			M2	1			2.4635 GHz	-41.53 dBm			M3	1			2.5 GHz	-57.98 dBm			M4	1			2.483513 GHz	-41.53 dBm										
Marker	Type	Ref	Trc	X-value	Y-value	Function	Function Result																																												
M1	1			2.460718 GHz	1.69 dBm																																														
M2	1			2.4635 GHz	-41.53 dBm																																														
M3	1			2.5 GHz	-57.98 dBm																																														
M4	1			2.483513 GHz	-41.53 dBm																																														

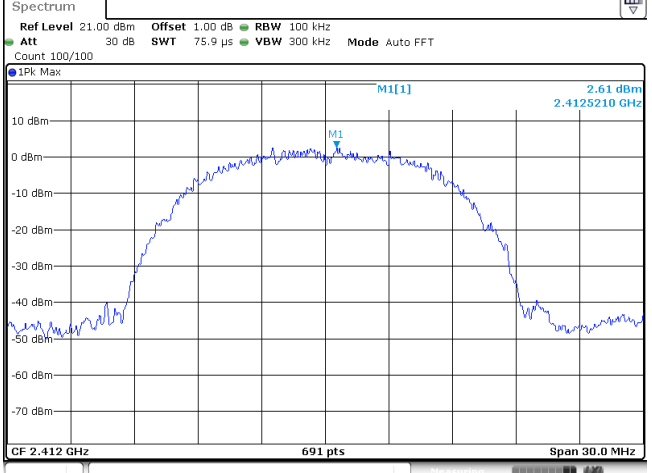
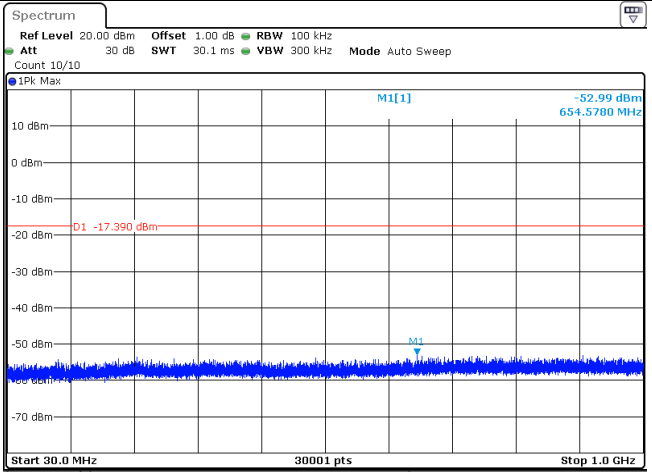
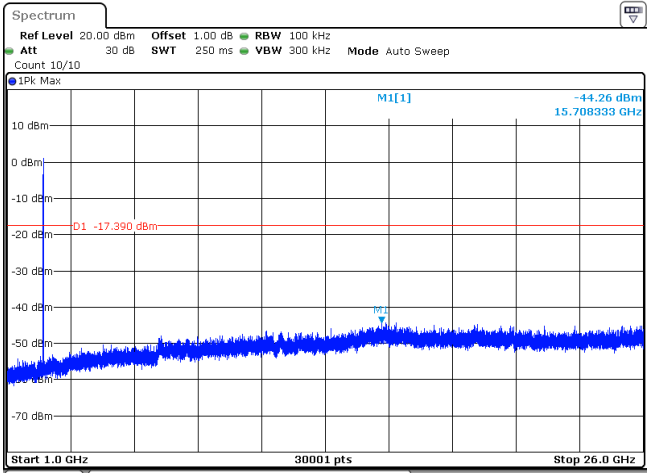
Test Item:	SE	Type:	802.11 b
CH01 Reference level		 <p>Spectrum</p> <p>Ref Level 21.00 dBm Offset 1.00 dB RBW 100 kHz Att 30 dB SWT 75.9 μs VBW 300 kHz Mode Auto FFT Count 100/100</p> <p>IPK Max</p> <p>M1[1] 2.61 dBm 2.4125210 GHz</p> <p>CF 2.412 GHz 691 pts Span 30.0 MHz</p> <p>Date: 23 JUL 2019 13:54:08</p>	
CH01 30MHz~1000MHz		 <p>Spectrum</p> <p>Ref Level 20.00 dBm Offset 1.00 dB RBW 100 kHz Att 30 dB SWT 30.1 ms VBW 300 kHz Mode Auto Sweep Count 10/10</p> <p>IPK Max</p> <p>M1[1] -52.99 dBm 654.5780 MHz</p> <p>D1 -17.390 dBm</p> <p>Start 30.0 MHz 30001 pts Stop 1.0 GHz</p> <p>Date: 23 JUL 2019 13:54:04</p>	
CH01 1GHz~26GHz		 <p>Spectrum</p> <p>Ref Level 20.00 dBm Offset 1.00 dB RBW 100 kHz Att 30 dB SWT 250 ms VBW 300 kHz Mode Auto Sweep Count 10/10</p> <p>IPK Max</p> <p>M1[1] -44.26 dBm 15.708333 GHz</p> <p>D1 -17.390 dBm</p> <p>Start 1.0 GHz 30001 pts Stop 26.0 GHz</p> <p>Date: 23 JUL 2019 13:54:50</p>	

CH06
Reference level

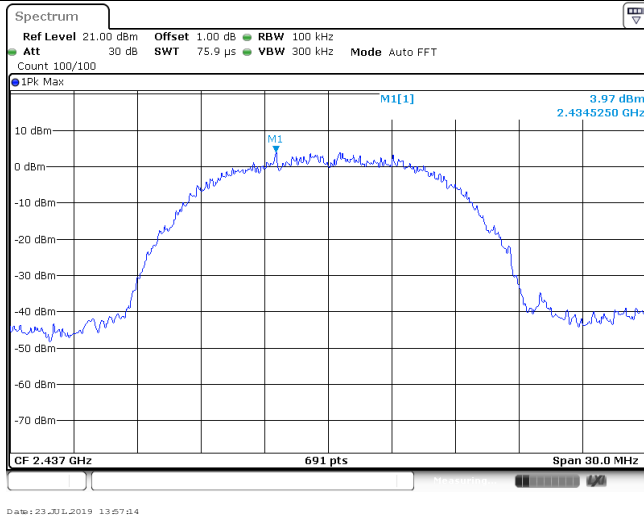

CH06
30MHz~1000MHz

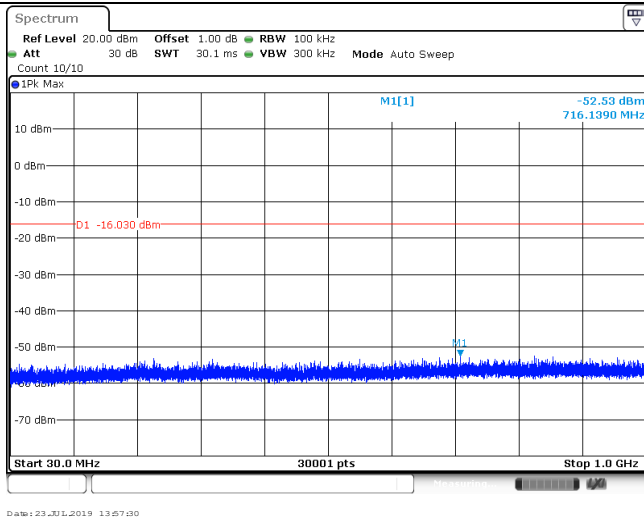

CH06
1GHz~26GHz

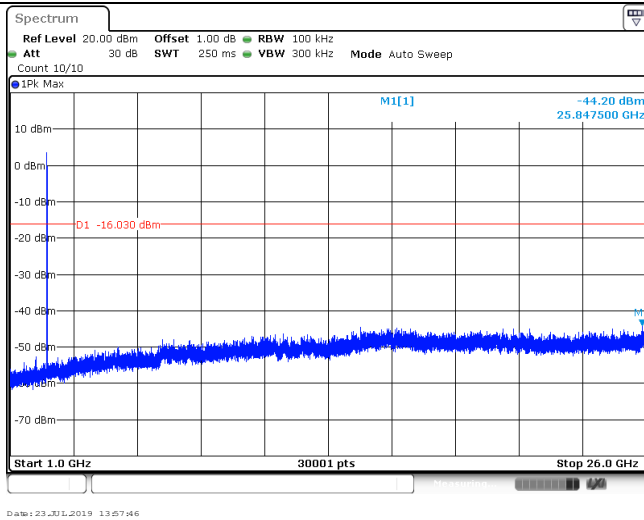

CH11
Reference level

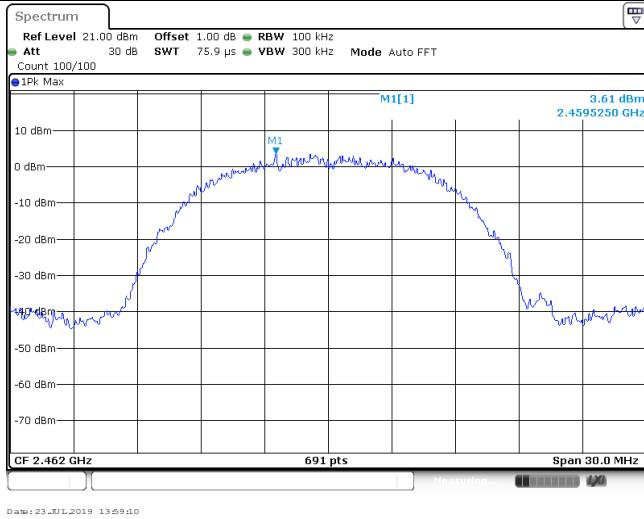

CH11
30MHz~1000MHz

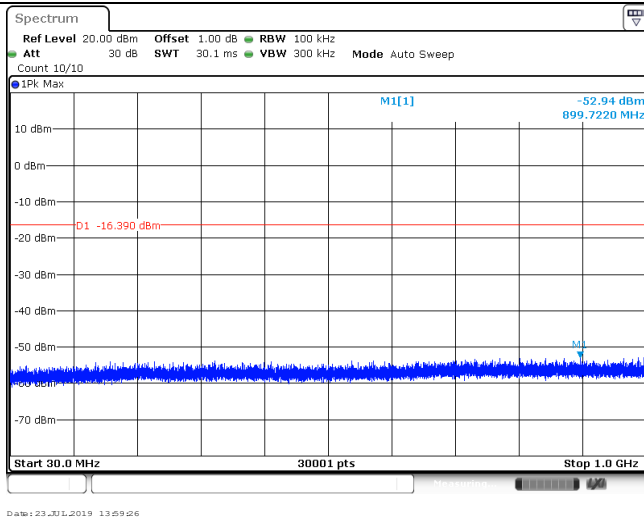

CH11
1GHz~26GHz

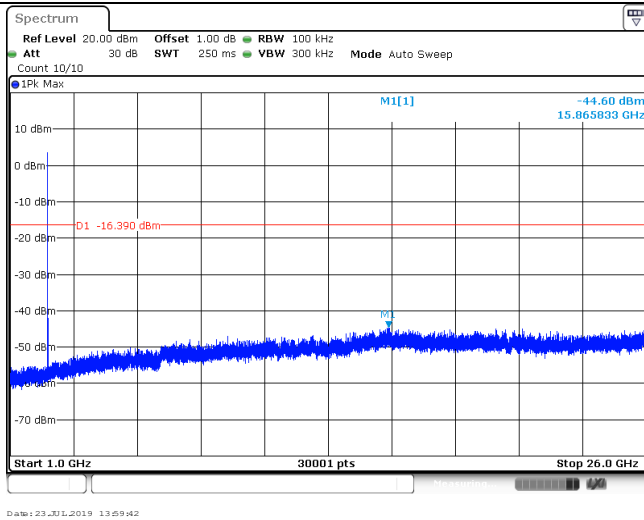

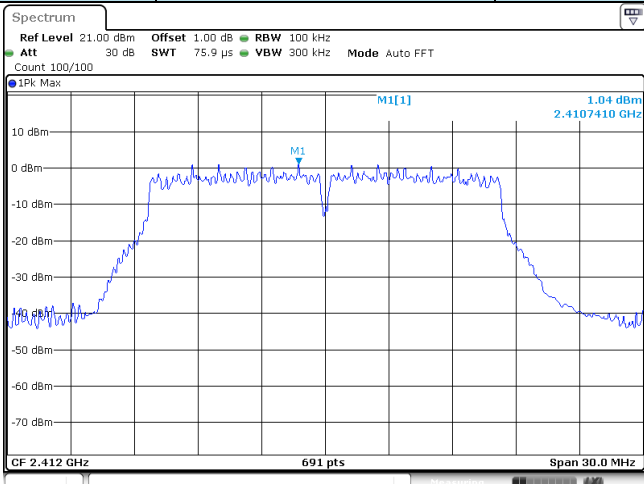
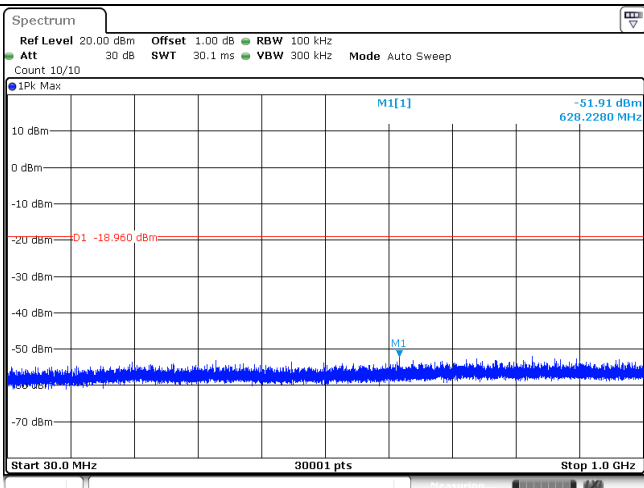
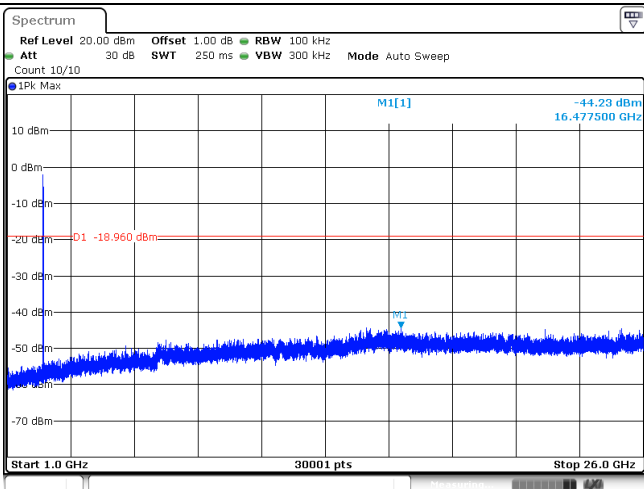
Test Item:	SE	Type:	802.11 g
CH01 Reference level			
CH01 30MHz~1000MHz			
CH01 1GHz~26GHz			

CH06
Reference level

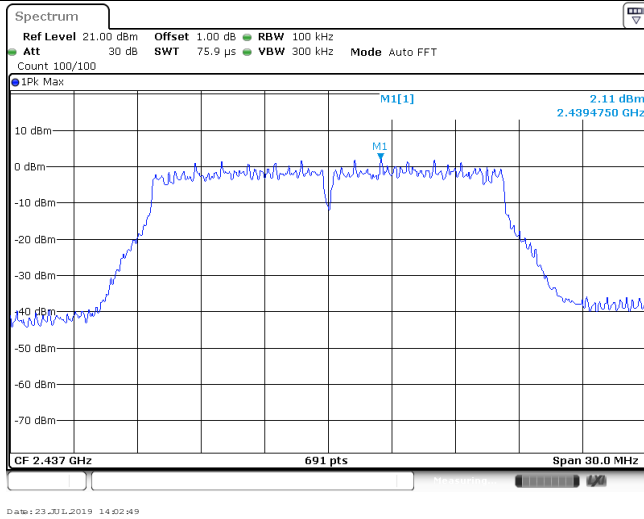

CH06
30MHz~1000MHz

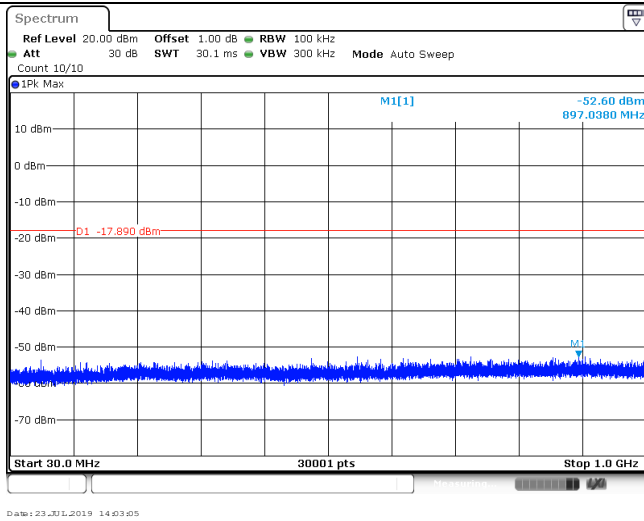

CH06
1GHz~26GHz

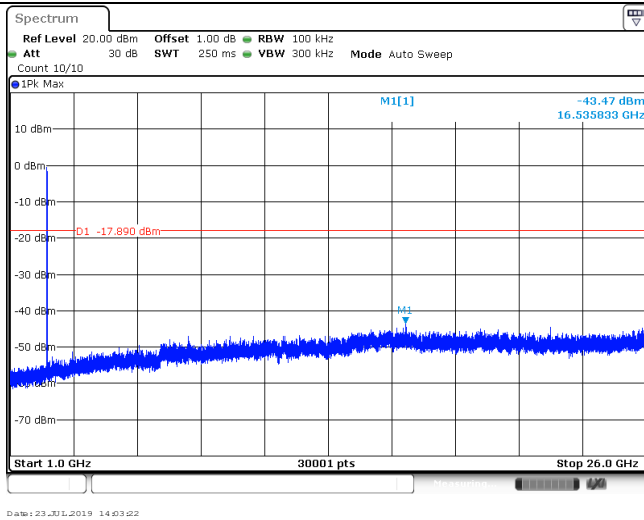

CH11
Reference level

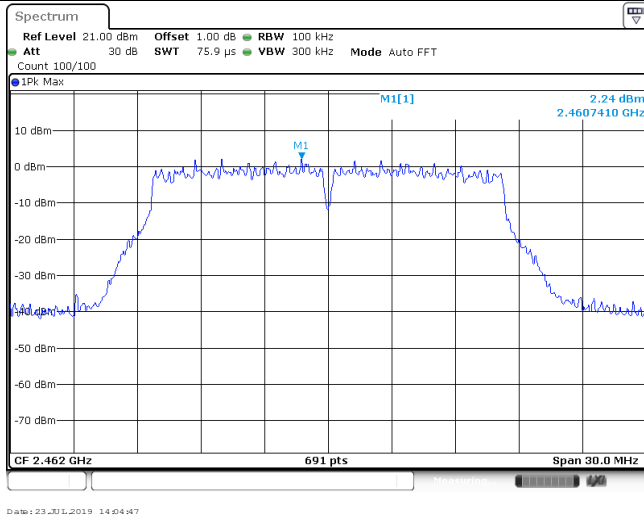

CH11
30MHz~1000MHz

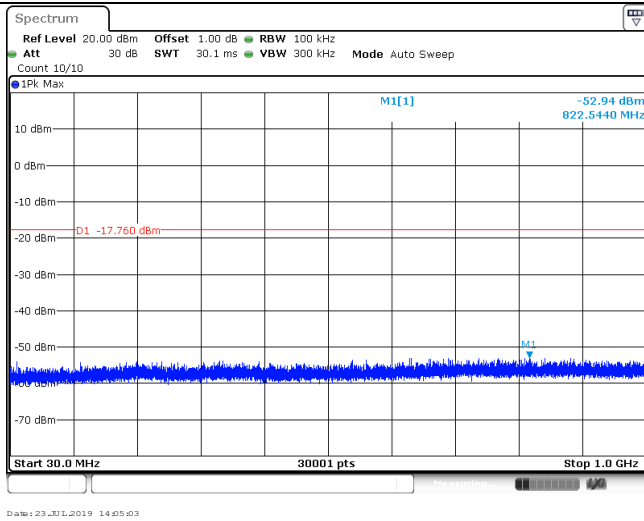

CH11
1GHz~26GHz

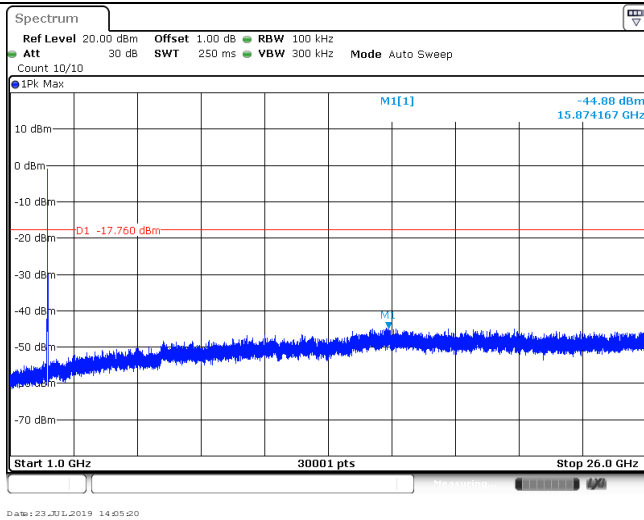

5.8. Spurious Emissions (radiated)

LIMIT

FCC CFR Title 47 Part 15 Subpart C Section 15.209

Frequency	Limit (dBuV/m @3m)	Value
30MHz-88MHz	40.00	Quasi-peak
88MHz-216MHz	43.50	Quasi-peak
216MHz-960MHz	46.00	Quasi-peak
960MHz-1GHz	54.00	Quasi-peak
Above 1GHz	54.00	Average
	74.00	Peak

TEST CONFIGURATION

- 9kHz ~30MHz

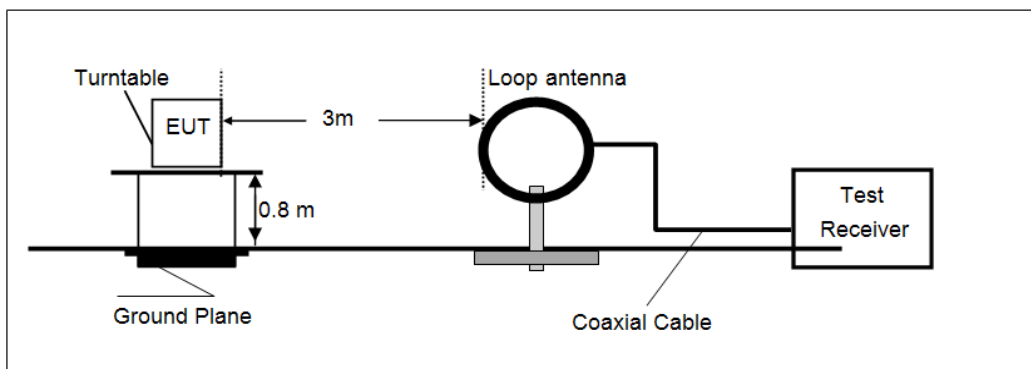

- 30MHz ~ 1GHz

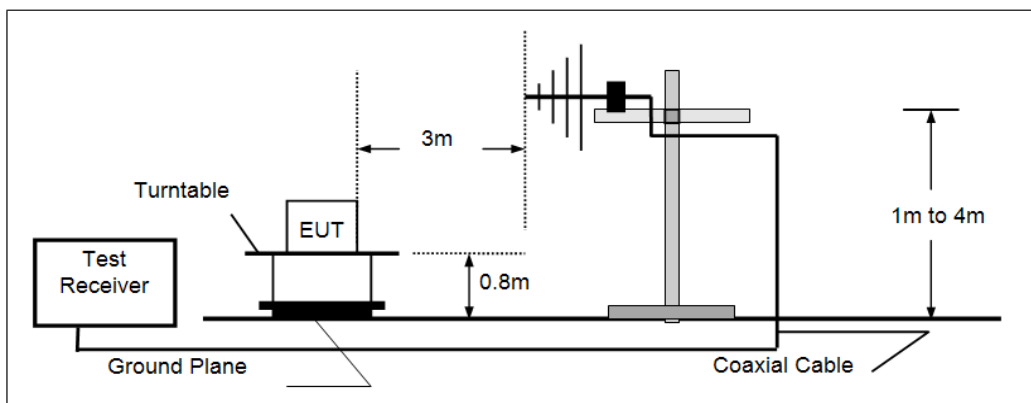

- Above 1GHz

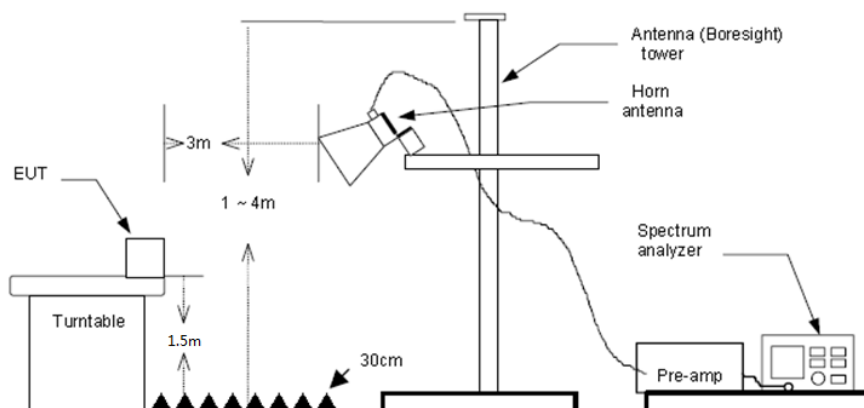

TEST PROCEDURE

1. The EUT was setup and tested according to ANSI C63.10:2013 for compliance to FCC 47CFR 15.247 requirements.
2. The EUT is placed on a turn table which is 0.8 meter above ground for below 1 GHz, and 1.5 m for above 1 GHz. The turn table is rotated 360 degrees to determine the position of the maximum emission level.
3. The EUT was set 3 meters from the receiving antenna, which was mounted on the top of a variable height antenna tower.
4. For each suspected emission, the EUT was arranged to its worst case and then tune the Antenna tower (from 1 m to 4 m) and turntable (from 0 degree to 360 degrees) to find the maximum reading. A pre-amp and a high pass filter are used for the test in order to get better signal level to comply with the guidelines.
5. Set to the maximum power setting and enable the EUT transmit continuously.
6. Use the following spectrum analyzer settings
 - (1) Span shall wide enough to fully capture the emission being measured;
 - (2) Below 1 GHz:
RBW=120 kHz, VBW=300 kHz, Sweep=auto, Detector function=peak, Trace=max hold;
If the emission level of the EUT measured by the peak detector is 3 dB lower than the applicable limit, the peak emission level will be reported. Otherwise, the emission measurement will be repeated using the quasi-peak detector and reported.
 - (3) From 1 GHz to 10th harmonic:
RBW=1MHz, VBW=3MHz Peak detector for Peak value.
RBW=1MHz, VBW=3MHz RMS detector for Average value.

TEST MODE:

Please refer to the clause 3.3

TEST RESULTS

Passed **Not Applicable**

Note:

- 1) Final Level =Receiver Read level + Antenna Factor + Cable Loss – Preamplifier Factor
- 2) The emission levels of other frequencies are very lower than the limit and not show in test report.

➤ **9kHz ~ 30MHz**

The EUT was pre-scanned the frequency band (9kHz~30MHz), found the radiated level lower than the limit, so don't show on the report.

➤ **30MHz ~1000MHz**

Have pre-scan all modulation mode, found the 802.11b mode CH01 which it was worst case, so only the worst case's data on the test report.

➤ 30MHz ~ 1GHz

Polarization: Vertical

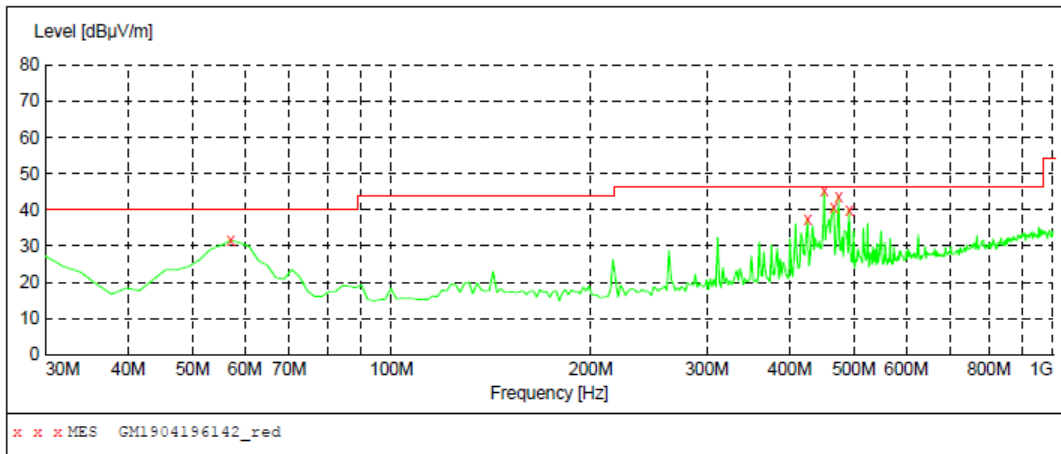

MEASUREMENT RESULT: "GM1904196142_red"

4/19/2019 9:28PM

Frequency MHz	Level dBµV/m	Transd dB	Limit dBµV/m	Margin dB	Det.	Height cm	Azimuth deg	Polarization
57.160000	31.40	-9.5	40.0	8.6	QP	100.0	80.00	VERTICAL
425.760000	37.20	-3.9	46.0	8.8	QP	100.0	354.00	VERTICAL
450.980000	44.50	-3.5	46.0	1.5	QP	100.0	91.00	VERTICAL
466.500000	40.60	-3.2	46.0	5.4	QP	100.0	359.00	VERTICAL
474.260000	43.40	-3.0	46.0	2.6	QP	100.0	321.00	VERTICAL
491.720000	40.10	-2.3	46.0	5.9	QP	100.0	105.00	VERTICAL

Polarization: Horizontal

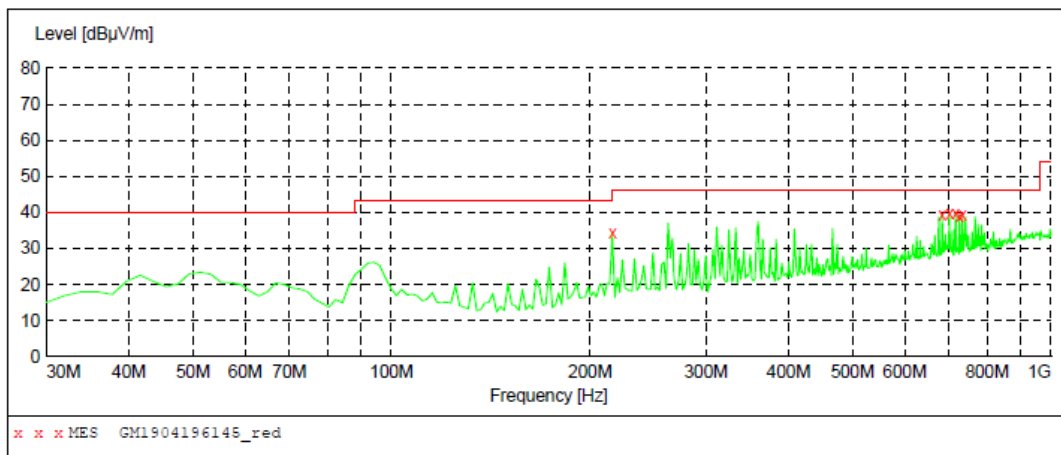

MEASUREMENT RESULT: "GM1904196145_red"

4/19/2019 9:53PM

Frequency MHz	Level dBµV/m	Transd dB	Limit dBµV/m	Margin dB	Det.	Height cm	Azimuth deg	Polarization
216.240000	33.20	-10.4	43.5	10.3	QP	100.0	288.00	HORIZONTAL
683.780000	39.10	2.0	46.0	6.9	QP	100.0	278.00	HORIZONTAL
701.240000	39.20	2.2	46.0	6.8	QP	100.0	267.00	HORIZONTAL
716.760000	39.40	2.5	46.0	6.6	QP	100.0	242.00	HORIZONTAL
726.460000	38.30	2.7	46.0	7.7	QP	100.0	187.00	HORIZONTAL
734.220000	39.20	3.0	46.0	6.8	QP	100.0	242.00	HORIZONTAL

➤ 1 GHz ~ 25 GHz

802.11b	CH01
---------	------

Suspected Data List

NO.	Freq. [MHz]	Reading [dB μ V/m]	Factor [dB]	Level [dB μ V/m]	Limit [dB μ V/m]	Margin [dB]	Polarity	Detector
1	3197.250	42.43	0.83	43.26	74.00	30.74	Horizontal	PK
2	4482.406	37.10	5.27	42.37	74.00	31.63	Horizontal	PK
3	5235.875	34.68	8.79	43.47	74.00	30.53	Horizontal	PK
4	7679.875	30.88	17.33	48.21	74.00	25.79	Horizontal	PK

Suspected Data List

NO.	Freq. [MHz]	Reading [dB μ V/m]	Factor [dB]	Level [dB μ V/m]	Limit [dB μ V/m]	Margin [dB]	Polarity	Detector
1	3191.375	45.90	0.80	46.70	74.00	27.30	Vertical	PK
2	4479.468	38.49	5.26	43.75	74.00	30.25	Vertical	PK
3	5225.593	35.60	8.84	44.44	74.00	29.56	Vertical	PK
4	7068.875	31.95	15.35	47.30	74.00	26.70	Vertical	PK

802.11b	CH06
---------	------

Suspected Data List

NO.	Freq. [MHz]	Reading [dB μ V/m]	Factor [dB]	Level [dB μ V/m]	Limit [dB μ V/m]	Margin [dB]	Polarity	Detector
1	3191.375	41.34	0.80	42.14	74.00	31.86	Horizontal	PK
2	3740.687	37.30	1.75	39.05	74.00	34.95	Horizontal	PK
3	4485.343	37.23	5.29	42.52	74.00	31.48	Horizontal	PK
4	5227.062	33.91	8.84	42.75	74.00	31.25	Horizontal	PK

Suspected Data List

NO.	Freq. [MHz]	Reading [dB μ V/m]	Factor [dB]	Level [dB μ V/m]	Limit [dB μ V/m]	Margin [dB]	Polarity	Detector
1	3189.906	45.19	0.79	45.98	74.00	28.02	Vertical	PK
2	3734.812	37.63	1.73	39.36	74.00	34.64	Vertical	PK
3	4483.875	38.09	5.28	43.37	74.00	30.63	Vertical	PK
4	5247.625	34.90	8.73	43.63	74.00	30.37	Vertical	PK

802.11b					CH11			
Suspected Data List								
NO.	Freq. [MHz]	Reading [dB μ V/m]	Factor [dB]	Level [dB μ V/m]	Limit [dB μ V/m]	Margin [dB]	Polarity	Detector
1	3186.968	42.28	0.77	43.05	74.00	30.95	Horizontal	PK
2	4494.156	36.32	5.32	41.64	74.00	32.36	Horizontal	PK
3	5238.812	33.60	8.77	42.37	74.00	31.63	Horizontal	PK
4	6710.500	31.84	13.44	45.28	74.00	28.72	Horizontal	PK

Suspected Data List								
NO.	Freq. [MHz]	Reading [dB μ V/m]	Factor [dB]	Level [dB μ V/m]	Limit [dB μ V/m]	Margin [dB]	Polarity	Detector
1	2996.031	40.77	-0.10	40.67	74.00	33.33	Vertical	PK
2	3191.375	46.08	0.80	46.88	74.00	27.12	Vertical	PK
3	4491.218	35.70	5.31	41.01	74.00	32.99	Vertical	PK
4	5230.000	34.04	8.82	42.86	74.00	31.14	Vertical	PK

Remark:

1. Final Level = Receiver Read level + Antenna Factor + Cable Loss – Preamplifier Factor
2. The peak level is lower than average limit(54 dB μ V/m), this data is the too weak instrument of signal is unable to test.
3. The emission levels of other frequencies(test frequency band is 1GHz to 25GHz) are very lower than the limit and not show in test report.

802.11g

CH01

Suspected Data List

NO.	Freq. [MHz]	Reading [dB μ V/m]	Factor [dB]	Level [dB μ V/m]	Limit [dB μ V/m]	Margin [dB]	Polarity	Detector
1	3191.375	40.60	0.80	41.40	74.00	32.60	Horizontal	PK
2	3740.687	36.92	1.75	38.67	74.00	35.33	Horizontal	PK
3	4482.406	36.34	5.27	41.61	74.00	32.39	Horizontal	PK
4	5225.593	34.07	8.84	42.91	74.00	31.09	Horizontal	PK

Suspected Data List

NO.	Freq. [MHz]	Reading [dB μ V/m]	Factor [dB]	Level [dB μ V/m]	Limit [dB μ V/m]	Margin [dB]	Polarity	Detector
1	3185.500	45.50	0.76	46.26	74.00	27.74	Vertical	PK
2	3589.406	39.32	1.41	40.73	74.00	33.27	Vertical	PK
3	4497.093	36.65	5.34	41.99	74.00	32.01	Vertical	PK
4	5108.093	34.27	8.81	43.08	74.00	30.92	Vertical	PK

802.11g

CH06

Suspected Data List

NO.	Freq. [MHz]	Reading [dB μ V/m]	Factor [dB]	Level [dB μ V/m]	Limit [dB μ V/m]	Margin [dB]	Polarity	Detector
1	3195.781	41.84	0.82	42.66	74.00	31.34	Horizontal	PK
2	3742.156	37.42	1.76	39.18	74.00	34.82	Horizontal	PK
3	4492.687	37.27	5.32	42.59	74.00	31.41	Horizontal	PK
4	5231.468	35.17	8.81	43.98	74.00	30.02	Horizontal	PK

Suspected Data List

NO.	Freq. [MHz]	Reading [dB μ V/m]	Factor [dB]	Level [dB μ V/m]	Limit [dB μ V/m]	Margin [dB]	Polarity	Detector
1	3185.500	45.28	0.76	46.04	74.00	27.96	Vertical	PK
2	4483.875	37.52	5.28	42.80	74.00	31.20	Vertical	PK
3	5241.750	36.23	8.76	44.99	74.00	29.01	Vertical	PK
4	6548.937	31.37	12.83	44.20	74.00	29.80	Vertical	PK

802.11g					CH11			
Suspected Data List								
NO.	Freq. [MHz]	Reading [dB μ V/m]	Factor [dB]	Level [dB μ V/m]	Limit [dB μ V/m]	Margin [dB]	Polarity	Detector
1	3186.968	41.14	0.77	41.91	74.00	32.09	Horizontal	PK
2	3746.562	37.25	1.78	39.03	74.00	34.97	Horizontal	PK
3	4483.875	37.08	5.28	42.36	74.00	31.64	Horizontal	PK
4	5240.281	33.31	8.77	42.08	74.00	31.92	Horizontal	PK
Suspected Data List								
NO.	Freq. [MHz]	Reading [dB μ V/m]	Factor [dB]	Level [dB μ V/m]	Limit [dB μ V/m]	Margin [dB]	Polarity	Detector
1	3185.500	45.11	0.76	45.87	74.00	28.13	Vertical	PK
2	3742.156	37.40	1.76	39.16	74.00	34.84	Vertical	PK
3	4482.406	36.77	5.27	42.04	74.00	31.96	Vertical	PK
4	5231.468	35.52	8.81	44.33	74.00	29.67	Vertical	PK

Remark:

1. Final Level = Receiver Read level + Antenna Factor + Cable Loss – Preamplifier Factor
2. The peak level is lower than average limit(54 dBuV/m), this data is the too weak instrument of signal is unable to test.
3. The emission levels of other frequencies(test frequency band is 1GHz to 25GHz) are very lower than the limit and not show in test report.

6. TEST SETUP PHOTOS

Conducted Emissions (AC Mains)



Radiated Emissions



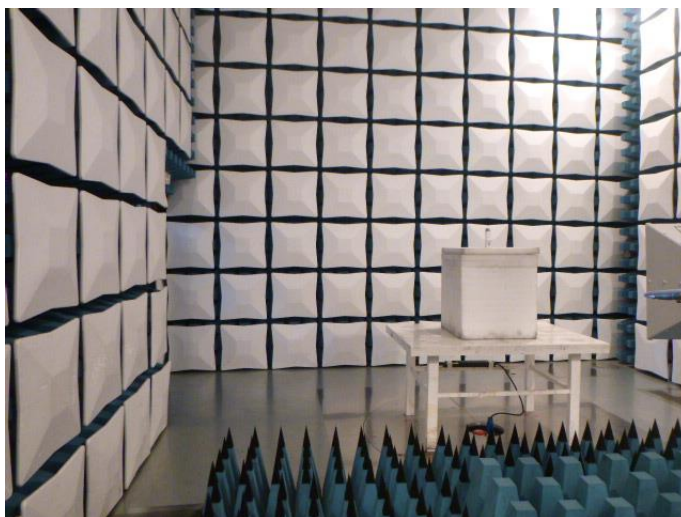

7. EXTERANAL AND INTERNAL PHOTOS

External Photos



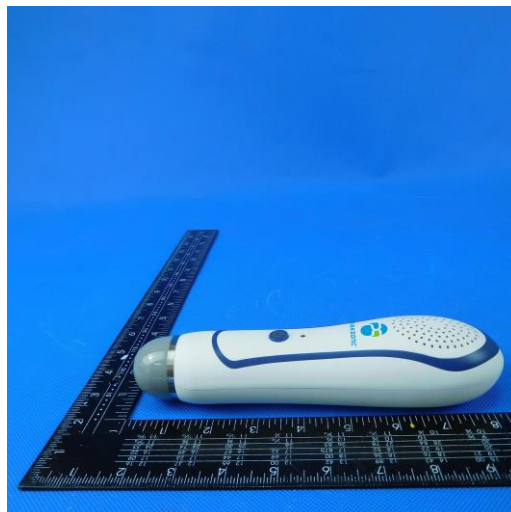
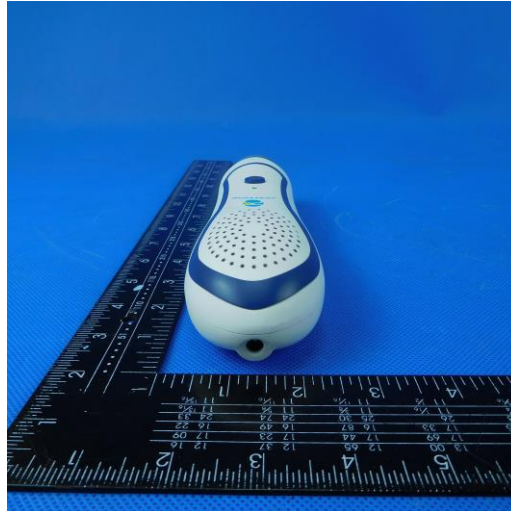



Internal Photos

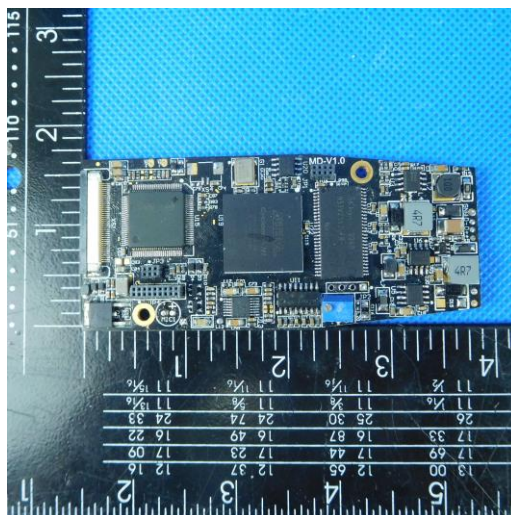
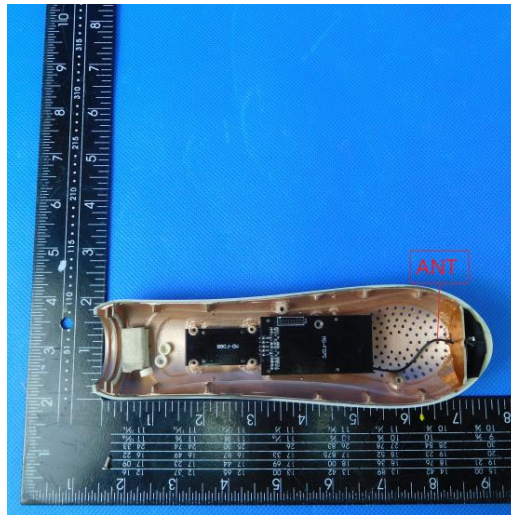

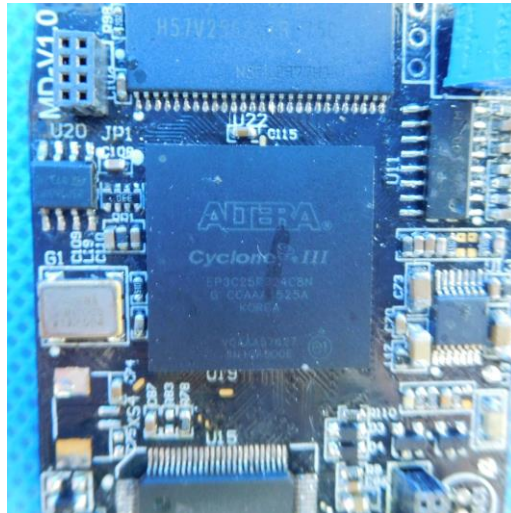

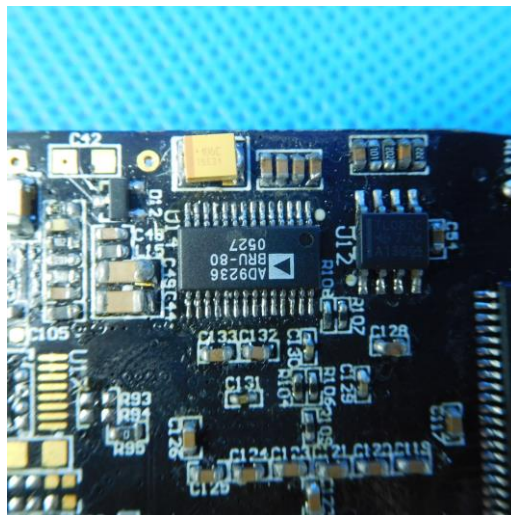
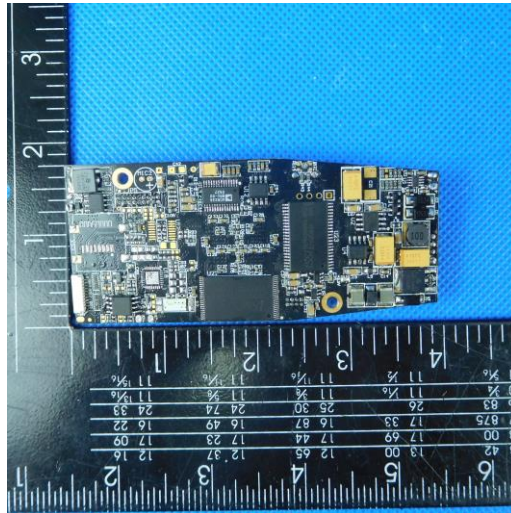

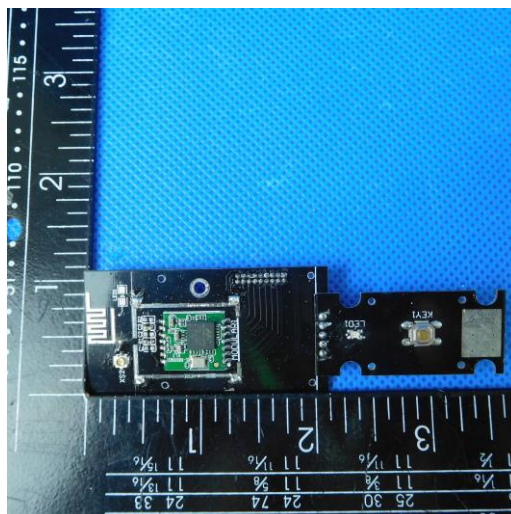
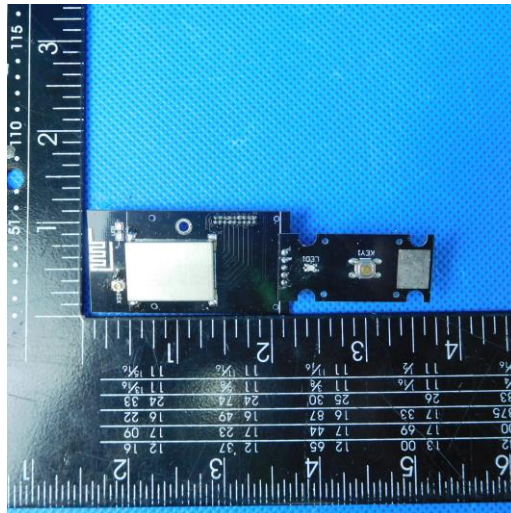
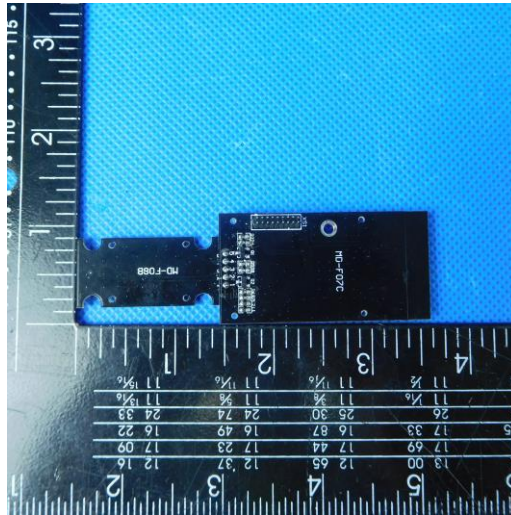

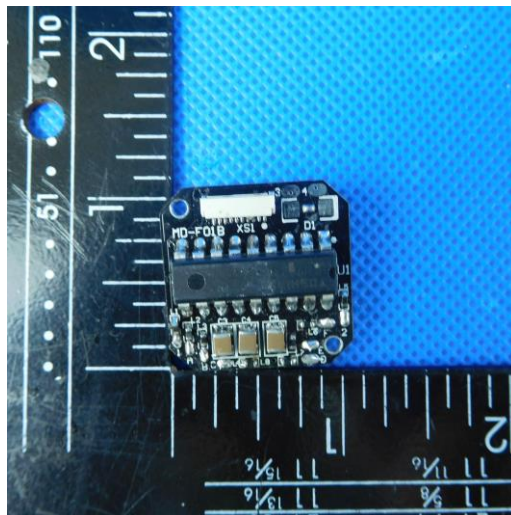
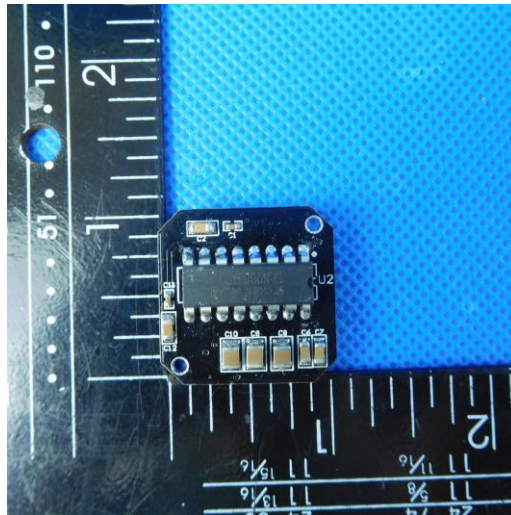

-----End of Report-----