



*OFLYCOMM*

# SHENZHEN OFEIXIN TECHNOLOGY LIMITED

**08723UE**

Wi-Fi 1T1R 11n + Bluetooth4.2

Combo Module

Datasheet

## Cover of Approval Sheet

PRODUCT NAME	Part No.	Description
O8723UE	FWAAO8723UE10	RTL8723DU-CG USB 1T1R 3.3V 12.9*12.2*2.3mm 11n WIFI+BT4.2 Shield CAN
	FWAAO8723UE20	RTL8723DU-CG USB 1T1R 3.3V 12.9*12.2*2.3mm 11n WIFI+BT4.2 2Antenna Shield CAN

Customer: \_\_\_\_\_

Customer P/N: \_\_\_\_\_

Signature: \_\_\_\_\_

Date: \_\_\_\_\_

Maker Information:

OFEIXIN TECHNOLOGY LIMITED

Room 503, Building A3, Area B, Songbai Industrial Park, Minghuan East Road,

Shangcun Community, Gongming Street, Guangming District, Shenzhen

**Revision History**

<b>Version</b>	<b>Date</b>	<b>Description</b>	<b>Draft</b>	<b>Approved</b>
1.0	2022-07-05	-Preliminary Project version	CCJ	Turbo
1.1	2022-08-11	-Addition the description	CCJ	Turbo
1.2	2023-02-15	- Pinout definition, photo, working temperature update	CCJ	Turbo

OFLYCOMM

## CONTENTS

<b>1.OVERVIEW .....</b>	<b>4</b>
1.1 INTRODUCTION .....	4
1.2 FEATURES .....	4
1.3 BLOCK DIAGRAM .....	4
1.4 GENERAL SPECIFICATION .....	5
1.5 RECOMMENDED OPERATING RATING .....	5
<b>2. RF SPECIFICATION .....</b>	<b>5</b>
2.1 WI-FI RF SPECIFICATION .....	5
2.2 BT RF SPECIFICATION .....	6
<b>3.PIN ASSIGNMENTS .....</b>	<b>6</b>
3.1 PIN OUTLINE .....	6
3.2 PIN DEFINITION .....	6
<b>4.DIMENSIONS .....</b>	<b>7</b>
4.1PHYSICAL DIMENSIONS AND MODULE PHOTO .....	7
4.2 MODULE PHYSICAL DIMENSIONS .....	8
4.3 LAYOUT RECOMMENDATION .....	9
<b>5 REFERENCE DESIGN .....</b>	<b>9</b>
5.1 REFERENCE SCHEMATIC .....	9
5.2 EXTERNAL ANTENNA .....	10
5.3 TIMING INFORMATION .....	10
5.4 REAL-WORLD TESTING .....	11
<b>6 RECOMMENDED REFLOW PROFILE .....</b>	<b>11</b>
<b>7 PACKAGE .....</b>	<b>12</b>
7.1 REEL .....	12
7.2 STORAGE TEMPERATURE AND HUMIDITY .....	12

# 1. Overview

## 1.1 Introduction

O8723UE is a highly integrated single-chip 802.11b/g/n 1T1R WLAN, and an integrated Bluetooth Smart Ready single chip with USB 2.0 multi-function, board size is 12.2mm x 13mm. The module provides simple legacy and 20MHz/40MHz co-existence mechanisms to ensure backward and network compatibility and Bluetooth can support BT2.1+EDR/BT3.0 and BT4.2.

## 1.2 Features

- 802.11b/g/n 1T1R WLAN and Bluetooth single chip
- Complies with USB2.0 for WLAN and BT controller
- IEEE standards support: IEEE 802.11b, IEEE 802.11g, IEEE 802.11n, IEEE 802.11d, IEEE 802.11e, IEEE 802.11h, IEEE 802.11i
- Fully Qualified for Bluetooth 2.1+EDR specification including both 2Mbps and 3Mbps modulation mode
- Fully qualified for Bluetooth 4.2 Dual mode
- Enterprise level security which can apply WPA/WPA2 certification for Wi-Fi

## 1.3 Block Diagram

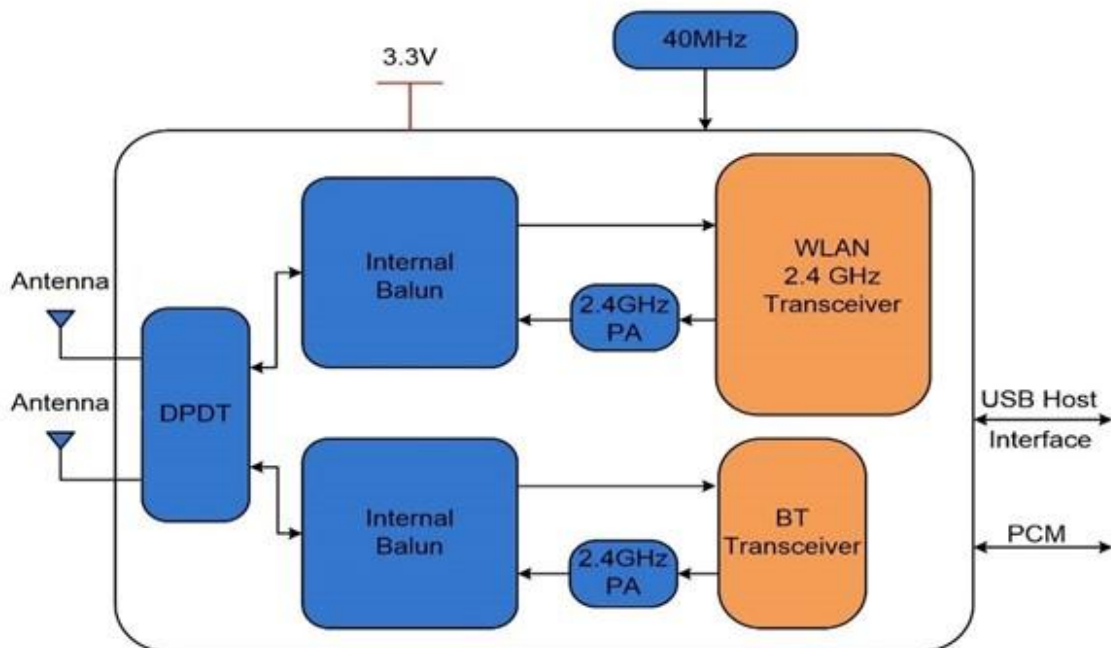

## 1.4 General Specification

Model Name	O8723UE
Product Description	Support Wi-Fi/Bluetooth functionalities
Dimension	L x W x H: 12.2 x 13 x 2.3 (typical) mm
Wi-Fi Interface	USB2.0
BT Interface	USB2.0
Operating temperature	0°C to 70°C
Storage temperature	-55°C to 85°C

Note: The module can work normally at -30°C to 85°C

## 1.5 Recommended Operating Rating

Feature	Minimum	Type	Maximum	Units
Operating Temperature*	-30	25	85	°C
VCC	3.15	3.3	3.45	V
Power Consumption (Type VCC)	TX (2.4G HT40)	223 mA		
	RX (2.4G HT40)	92 mA		
	BT on	8.5 mA		

## 2. RF Specification

### 2.1 Wi-Fi RF Specification

Feature	Description		
Operating Frequency	2.400~2.462GHz		
Standards	Wi-Fi: IEEE 802.11b/g/n & Wi-Fi compliant		
Operating Channel	2.4GHz : Ch1~11		
Modulation	802.11b : CCK 802.11 g/n : OFDM /64-QAM、16-QAM、QPSK、BPSK		
PHY Data rates	Wi-Fi:802.11b:11,5.5,2,1Mbps 802.11g:54,48,36,24,18,12,9,6Mbps 802.11n: up to 150Mbps		
Output Power, tolerance $\pm 1.5$ dB			
Protocol Standard	Data Rate	Spec.(dBm)	EVM(dB)
802.11b	@11Mbps	16	$\leq -10$
802.11g	@54Mbps	15	$\leq -25$
802.11n	@MCS 7	14	$\leq -28$
Receiver Sensitivity CCK modulation PER $\leq 8\%$ 、OFDM modulation PER $\leq 10\%$			
Protocol Standard	Data Rate	Spec.(dBm)	
802.11b	1Mbps	-91	
	11Mbps	-85	
802.11g	6Mbps	-87	
	54Mbps	-70	

802.11n	HT20_MCS 0	-87
	HT20_MCS 7	-69
	HT40_MCS 0	-84
	HT40_MCS 7	-66

### 2.2 BT RF Specification

Feature	Description		
Operating Frequency	2.400~2.4835GHz		
Number of Channels	79 channels for classic、 40 channels for BLE		
Standards	V2.1+EDR/BT v3.0/BT v3.0+HS/BT v4.2		
Modulation	8DPSK, $\pi/4$ DQPSK, GFSK		
PHY Data rates	1 Mbps for Basic Rate 2,3 Mbps for Enhanced Data Rate		
Output Power	Min(dBm)	Typical(dBm)	Max(dBm)
	6	8	10
Sensitivity @ BER=0.1% for GFSK (1Mbps)		-89	
Sensitivity @ BER=0.01% for $\pi/4$ -DQPSK (2Mbps)		-86	
Sensitivity @ BER=0.01% for 8DPSK (3Mbps)		-83	

## 3.Pin Assignments

### 3.1 Pin Outline

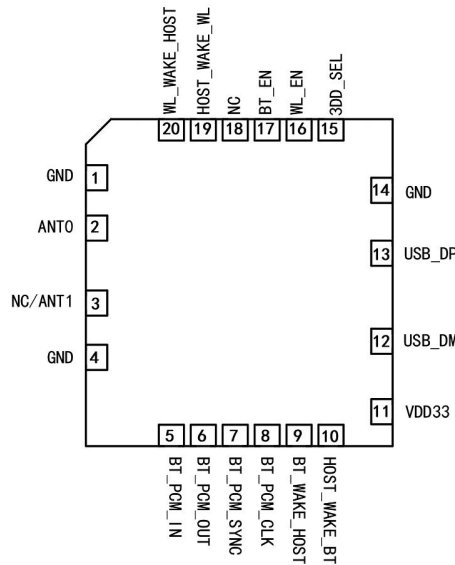

### 3.2 Pin Definition

NO	Name	Type	Description	Voltage
1	GND	-	Ground connections	
2	ANT 0	I/O	Single antenna is for WiFi and Bluetooth, dual antenna is WiFi ANT	
3	NC/ANT1	-	NC if the version is single antenna,bluetooth antenna if dual antenna version	

4	GND	-	Ground connections	
5	BT_PCM_IN	I/O	BT_PCM_IN.If not used please NC, Don't connected to ground.	3.3V
6	BT_PCM_OUT	I/O	BT_PCM_OUT. If not used please NC, Don't connected to ground.	3.3V
7	BT_PCM_SYNC	I/O	BT_PCM_SYNC. If not used please NC, Don't connected to ground.	3.3V
8	BT_PCM_CLK	I/O	BT_PCM_CLK. If not used please NC, Don't connected to ground	3.3V
9	BT_WAKE_HOST	O	Bluetooth device wake up host IC pin GPIO14, pull high boot to test mode. pull low boot to normal mode. be careful to using this pin.	3.3V
10	HOST_WAKE_BT	I	Host wake up Bluetooth device C pin GPIO13	3.3V
11	VDD33	-	Main power voltage source input 3.3V	3.3V
12	USB_DM	I/O	USB2.0 differential pair for WLAN And Bluetooth	
13	USB_DP	I/O	USB2.0 differential pair for WLAN And Bluetooth	
14	GND	-	Ground connections	
15	3DD_SEL	I/O	Not connecting Don't connected to ground IC pin GPIO6	
16	WL_EN	I	WLAN disable Default pull high, external pull low disable WL	3.3V
17	BT_EN	I	Bluetooth disable Default pull high, external pull low disable BT	3.3V
18	NC	-	Not connecting (Don't connected to ground)	
19	HOST_WAKE_WL	I	Host wake up WLAN device IC pin BT_GPIO14	3.3V
20	WL_WAKE_HOST	O	WLAN device wake up host IC pin GPIO8	3.3V

## 4. Dimensions

### 4.1 Physical Dimensions and Module Photo

(Unit: mm)

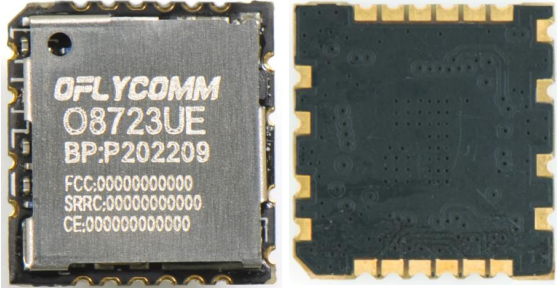
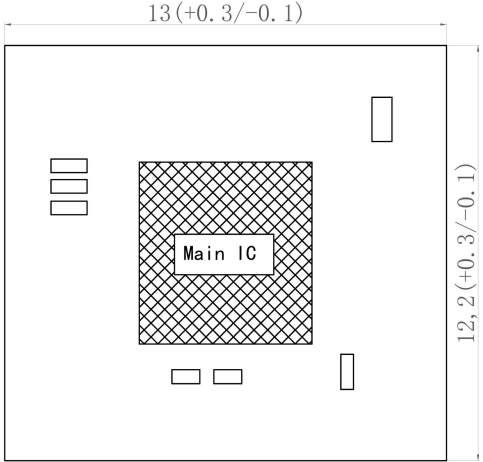
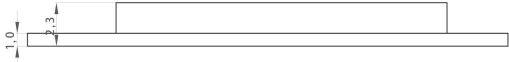

<p>L x W : 13 x 12.2(+0.3/-0.1) mm</p> 	
<p>H: 2.3 (±0.2)mm</p>	
<p>Weight</p>	<p>4.5g</p>

### 4.2 Module Physical Dimensions

(Unit: mm)

< TOP VIEW >

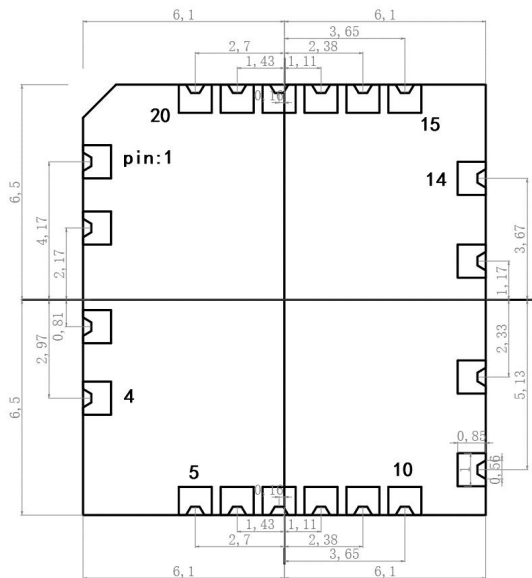

### 4.3 Layout Recommendation

(Unit: mm)

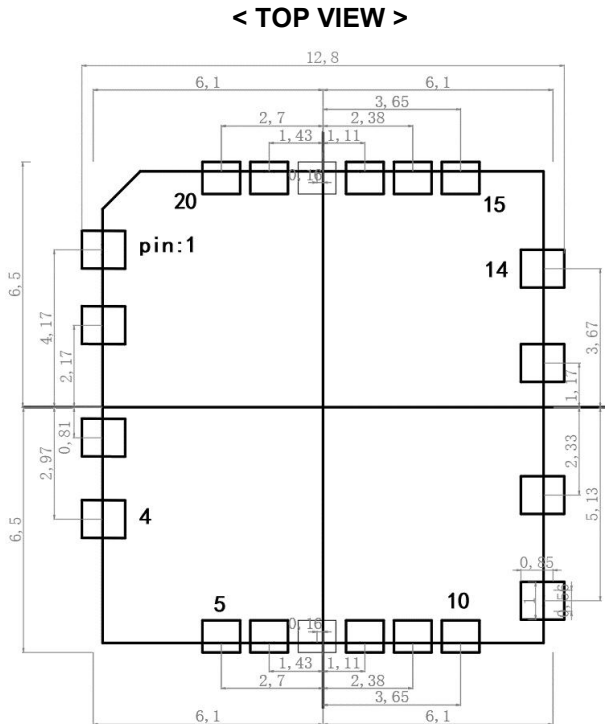

### 5 Reference Design

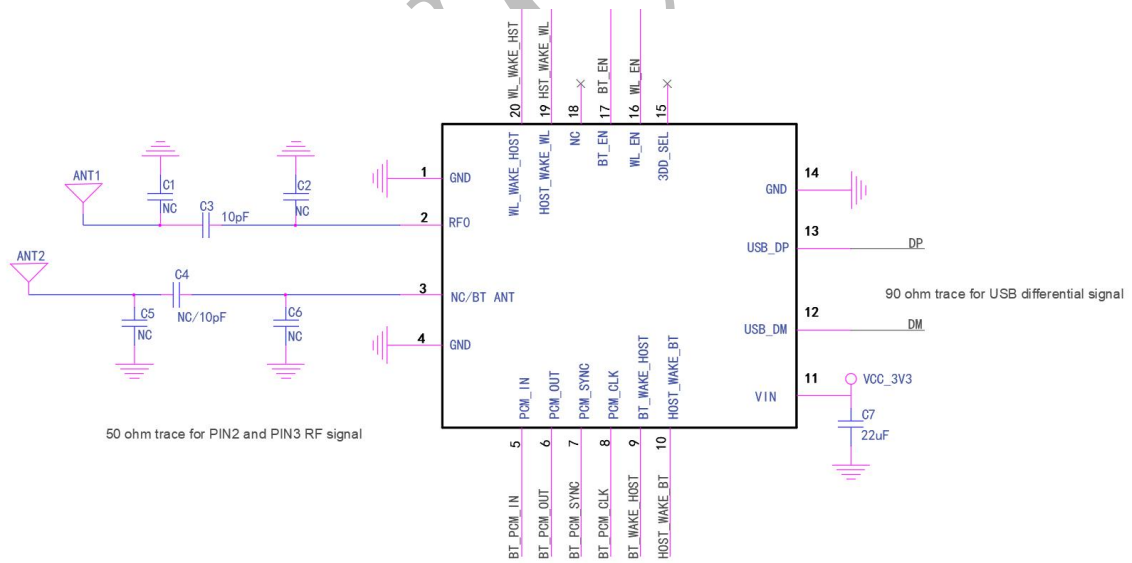

Note: 1, Please add 22uF cap for VCC\_3V3. 2, For USB 2.0 differential signal, requires 90 ohm impedance. 3, For PIN2 and PIN3 RF IO trace, keep 50 ohm impedance.

2, When the version is single antenna, ANT0 is WiFi and Bluetooth shared antenna, and ANT1 is NC. ANT0 is WiFi antenna and ANT1 is Bluetooth antenna when is dual antenna version.

### 5.2 External Antenna

When the customer selects an external antenna, the external antenna selected must meet the parameter requirements specified ,Impedance 50Ω

### 5.3 Timing information

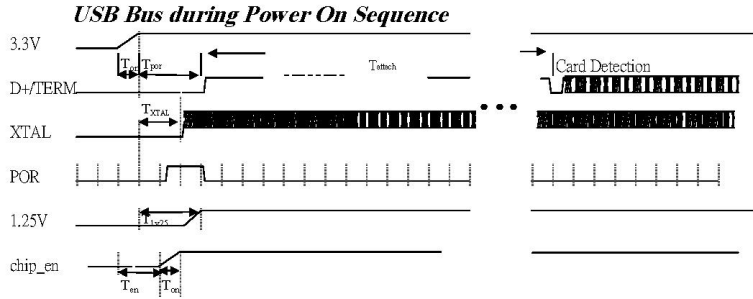

Figure 4 RTL8723DU USB Bus Power On Sequence

- T<sub>on</sub>: The main power ramp up duration
- T<sub>por</sub>: The power on reset releases and power management unit executes power on tasks
- T<sub>attach</sub>: USB attach state
- T<sub>stable</sub>: the duration from resistor attached to USB host starting card detection procedure

**The power on flow description:**

After main 3.3V ramp up, the internal power on reset is released by power ready detection circuit and the power management unit will be enabled. The power management unit enables the internal regulator and clock circuits. The power management unit also enables the USB circuits. USB analog circuits attach resistors to indicate the insertion of the USB device

Table 14. The typical timing range

	Unit	Min	Typical	Max
T <sub>on</sub>	ms	0.2	1.5	5
T <sub>por</sub>	ms	--	2	10
T <sub>xtal</sub>	ms	--	1.5	8
T <sub>attach</sub>	ms	100	250	--
T <sub>rst</sub>	ms	-	2	5
T <sub>en</sub>	ms	0	0	5

### PCM Interface Characteristics

The RTL8723D supports a PCM digital audio interface that is used for transmitting digital audio/voice data to/from the Audio Codec. Features are supported as below:

- Supports Master and Slave mode
- Programmable long/short Frame Sync
- Supports 8-bit/16-bit linear PCM formats
- PCM Master Clock Output: 64, 128, 256, or 512kHz
- Supports SCO/ESCO link

#### PCM Format

FrameSync is the synchronizing function used to control the transfer of DAC\_Data and ADC\_Data. A Long FrameSync indicates the start of ADC\_Data at the rising edge of FrameSync (Figure 7. Long FrameSync), and a Short FrameSync indicates the start of ADC\_Data at the falling edge of FrameSync (Figure 8. Short FrameSync).

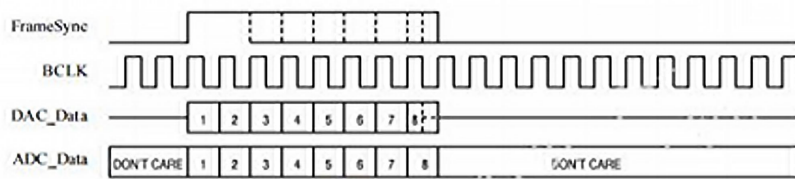

Figure 7. Long FrameSync

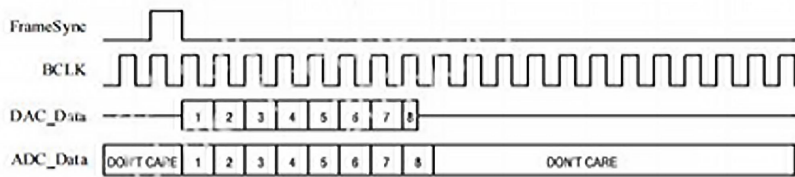

Figure 8. Short FrameSync

### 5.4 Real-world Testing

Protocol Standard	channel	Power (dBm)	EVM(dB)	Rx Sensitivity (dBm)
802.11b(11Mbps)	2412	17	-26.6	-88
	2437	16.8	-26.8	-88
	2472	17.2	-26.7	-88
802.11n(20Mbps_MCS7)	2412	14.6	-33	-71
	2437	14.1	-33.1	-71
	2472	14.7	-32.8	-71
802.11n(40Mbps_MCS7)	2422	14.9	-32.6	-69
	2437	14.2	-33.2	-69
	2472	14.1	-33.2	-69

Description: The test environment is: temperature 25 °C humidity 60%

## 6 Recommended Reflow Profile

Referred to IPC/JEDEC standard.

Peak Temperature : <260°C

Number of Times : 2 times max

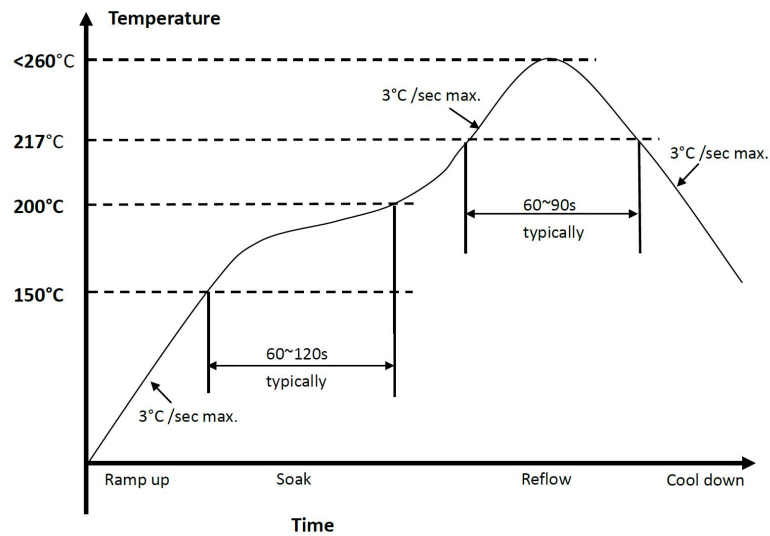

## 7 Package

### 7.1 Reel

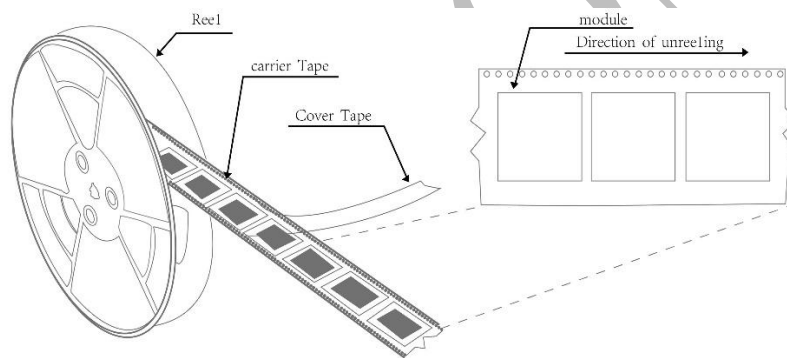

### 7.2 Storage Temperature And Humidity

- Storage Condition: Moisture barrier bag must be stored under 30°C, humidity under 85% RH. The calculated shelf life for the dry packed product shall be a 12 months from the bag seal date. Humidity indicator cards must be blue, <math><30\%</math>.
- Products require baking before mounting if humidity indicator cards reads > 30% temp < 30°C, humidity < 70% RH, over 96 hours.  
Baking condition: 125°C, 12 hours. Baking times: 1 time.

**THE END**

**RF exposure considerations**

This equipment complies with the FCC RF radiation exposure limits set forth for an uncontrolled environment. This equipment should be installed and operated with a minimum distance of 20cm between the radiator and any part of your body.

Contact SHENZHEN OFEIXIN TECHNOLOGY LIMITED will provide stand-alone modular transmitter test mode. Additional testing and certification may be necessary when multiple modules are used in a host.

To ensure compliance with all non-transmitter functions the host manufacturer is responsible for ensuring compliance with the module(s) installed and fully operational. For example, if a host was previously authorized as an unintentional radiator under the Supplier's Declaration of Conformity procedure without a transmitter certified module and a module is added, the host manufacturer is responsible for ensuring that after the module is installed and operational the host continues to be compliant with the Part 15B unintentional radiator requirements. Since this may depend on the details of how the module is integrated with the host, SHENZHEN OFEIXIN TECHNOLOGY LIMITED shall provide guidance to the host manufacturer for compliance with the Part 15B requirements.

FCC ID label on the final system must be labeled with "Contains FCC ID: 2AT5W-O8723UE" or "Contains transmitter module FCC ID: 2AT5W-O8723UE".

**FCC Warning**

This device complies with Part 15 of the FCC Rules. Operation is subject to the following two conditions:

(1) This device may not cause harmful interference, and (2) this device must accept any interference received, including interference that may cause undesired operation.

NOTE 1: Any changes or modifications to this unit not expressly approved by the party responsible for compliance could void the user's authority to operate the equipment.

**FCC Radiation Exposure Statement:**

This equipment complies with FCC radiation exposure limits set forth for an uncontrolled environment. End users must follow the specific operating instructions for satisfying RF exposure compliance.

Note 1: This module certified that complies with RF exposure requirement under mobile or fixed condition, this module is to be installed only in mobile or fixed applications.

A mobile device is defined as a transmitting device designed to be used in other than fixed locations and to generally be used in such a way that a separation distance of at least 20 centimeters is normally maintained between the transmitter's radiating structure(s) and the body of the user or nearby persons. Transmitting devices designed to be used by consumers or workers that can be easily re-located, such as wireless devices associated with a personal computer, are considered to be mobile devices if they meet the 20 centimeter separation requirement.

A fixed device is defined as a device is physically secured at one location and is not able to be easily moved to another location.

Note 2: Any modifications made to the module will void the Grant of Certification, this module is limited to OEM installation only and must not be sold to end-users, end-user has no manual instructions to remove or install the device, only software or operating procedure shall be placed in the end-user operating manual of final products.

Note 3: Additional testing and certification may be necessary when multiple modules are used.

Note 4: The module may be operated only with the antenna with which it is authorized. Any antenna that is of the same type and of equal or less directional gain as an antenna that is authorized with the intentional radiator may be marketed with, and used with, that intentional radiator.

Note 5: For all products market in US, OEM has to limit the operation channels in CH1 to CH11 for 2.4G band by supplied firmware programming tool. OEM shall not supply any tool or info to the end-user regarding to Regulatory Domain change.

Caution: Intended for sale and application in a business environment.

Use the Product in the environment with the temperature Between 0 C and 70 C; Otherwise, it may damage your product. Products can only be used below 2000m altitude

For the following equipment:

Product Name: Wi-Fi 1T1R 11n + Bluetooth4.2 Combo Module Brand

Name: /

Model No.: O8723UE

SHENZHEN OFEIXIN TECHNOLOGY LIMITED

E-mail: nickren@ofeixin.com

hereby declares that this [Name: Wi-Fi 1T1R 11n + Bluetooth4.2 Combo Module, Model: O8723UE] is in compliance with the essential requirements and other relevant provisions of Directive 2014/53/EU.

This product is intended for sale and application in a business environment.

RED Article 10 2

-This product can be used across EU member states

RED Article 10 10

-The product is class 1 product, No restrictions

The RF distance between body and product is 20mm

Frequency Range:

2402-2480MHz

Max.RF Output Power: 9.89dBm (EIRP)

Frequency Range:

2412-2472MHz for 802.11b/g/n (HT20)

2422-2462MHz for 802.11n (HT40)

Max.RF Output Power: 17.86dBm (EIRP)