



RF TEST REPORT

Applicant SAGETEL (HONG KONG) CO. LIMITED
FCC ID 2AT2L-HINTO-LITE
Product 4G Feature Phone
Brand altice; Sagetel
Model altice F4; Sagetel Hinto lite
Report No. R2205A0384-R2
Issue Date June 1, 2022

TA Technology (Shanghai) Co., Ltd. tested the above equipment in accordance with the requirements in **FCC CFR47 Part 2 (2021)/ FCC CFR 47 Part 24E (2021)**. The test results show that the equipment tested is capable of demonstrating compliance with the requirements as documented in this report.

Prepared by: Peng Tao

Approved by: Kai Xu

TA Technology (Shanghai) Co., Ltd.

No.145, Jintang Rd, Tangzhen Industry Park, Pudong Shanghai, China

TEL: +86-021-50791141/2/3

FAX: +86-021-50791141/2/3-8000



TABLE OF CONTENT

1. Test Laboratory	4
1.1. Notes of the test report	4
1.2. Test facility	4
1.3. Testing Location	4
2. General Description of Equipment under Test	5
2.1. Applicant and Manufacturer Information	5
2.2. General information	5
3. Applied Standards	7
4. Test Configuration	8
5. Test Case	10
5.1. RF Power Output and Effective Isotropic Radiated Power	10
5.2. Occupied Bandwidth	11
5.3. Band Edge Compliance	12
5.4. Peak-to-Average Power Ratio (PAPR)	13
5.5. Frequency Stability	14
5.6. Spurious Emissions at Antenna Terminals	16
5.7. Radiates Spurious Emission	17
6. Test Results	20
6.1. RF Power Output and Effective Isotropic Radiated Power	20
6.2. Occupied Bandwidth	24
6.3. Band Edge Compliance	34
6.4. Peak-to-Average Power Ratio (PAPR)	44
6.5. Frequency Stability	46
6.6. Spurious Emissions at Antenna Terminals	50
6.7. Radiates Spurious Emission	55
7. Main Test Instruments	58
ANNEX A: The EUT Appearance	59
ANNEX B: Test Setup Photos	60



Summary of measurement results

No.	Test Case	Clause in FCC rules	Verdict
1	RF Power Output and Effective Isotropic Radiated Power	2.1046 24.232(c)	PASS
2	Occupied Bandwidth	2.1049	PASS
3	Band Edge Compliance	2.1051 /24.238(a)	PASS
4	Peak-to-Average Power Ratio	24.232/KDB 971168 D01(5.7)	PASS
5	Frequency Stability	2.1055 / 24.235	PASS
6	Spurious Emissions at Antenna Terminals	2.1051 / 24.238(a)	PASS
7	Radiates Spurious Emission	2.1053 / 24.238(a)	PASS
Date of Testing: May 9, 2022 ~ May 13, 2022 and May 22, 2022			
Date of Sample Received: May 5, 2022			
Note: PASS: The EUT complies with the essential requirements in the standard. FAIL: The EUT does not comply with the essential requirements in the standard. All indications of Pass/Fail in this report are opinions expressed by TA Technology (Shanghai) Co., Ltd. based on interpretations and/or observations of test results. Measurement Uncertainties were not taken into account and are published for informational purposes only.			



1. Test Laboratory

1.1. Notes of the test report

This report shall not be reproduced in full or partial, without the written approval of **TA technology (shanghai) co., Ltd.** The results documented in this report apply only to the tested sample, under the conditions and modes of operation as described herein. Measurement Uncertainties were not taken into account and are published for informational purposes only. This report is written to support regulatory compliance of the applicable standards stated above.

1.2. Test facility

FCC (Designation number: CN1179, Test Firm Registration Number: 446626)

TA Technology (Shanghai) Co., Ltd. has been listed on the US Federal Communications Commission list of test facilities recognized to perform measurements.

A2LA (Certificate Number: 3857.01)

TA Technology (Shanghai) Co., Ltd. has been listed by American Association for Laboratory Accreditation to perform measurement.

1.3. Testing Location

Company: TA Technology (Shanghai) Co., Ltd.
Address: No.145, Jintang Rd, Tangzhen Industry Park, Pudong
City: Shanghai
Post code: 201201
Country: P. R. China
Contact: Xu Kai
Telephone: +86-021-50791141/2/3
Fax: +86-021-50791141/2/3-8000
Website: <http://www.ta-shanghai.com>
E-mail: xukai@ta-shanghai.com

2. General Description of Equipment under Test

2.1. Applicant and Manufacturer Information

Applicant	SAGETEL (HONG KONG) CO. LIMITED
Applicant address	FLAT D39. 8/F WAH LOK IND CTR PHASE 2, 31-35 SHAN MEI ST FO TAN SHATIN NT
Manufacturer	SAGETEL (HONG KONG) CO. LIMITED
Manufacturer address	FLAT D39. 8/F WAH LOK IND CTR PHASE 2, 31-35 SHAN MEI ST FO TAN SHATIN NT

2.2. General information

EUT Description			
Model	altice F4; Sagetel Hinto lite		
IMEI	352847500227382		
Hardware Version	V01E		
Software Version	ALTICE_GX2421L_SS_L_V01_FCC_220428		
Power Supply	Battery / AC adapter		
Antenna Type	PIFA Antenna		
Antenna Gain	Band	Gain(dBi)	
	GSM1900	1.5	
	WCDMA Band II	1.0	
	LTE Band 2	-1.0	
Test Mode(s)	GSM1900; WCDMA Band II; LTE Band 2;		
Test Modulation	(GSM/GPRS)GMSK, (EGPRS) GMSK/ 8PSK; (WCDMA) BPSK, QPSK; (LTE)QPSK, 16QAM		
GPRS Multislot Class	12		
EGPRS Multislot Class	12		
HSDPA UE Category	24		
HSUPA UE Category	6		
LTE Category	4		
Maximum E.I.R.P	GSM 1900:	28.92dBm	
	WCDMA Band II	22.19dBm	
	LTE Band 2:	20.41dBm	
Rated Power Supply Voltage	3.8V		
Operating Voltage	Minimum: 3.6V Maximum: 4.2V		
Operating Temperature	Lowest: -10°C Highest: +55°C		
Testing Temperature	Lowest: -30°C Highest: +50°C		
Operating Frequency Range(s)	Band	Tx (MHz)	Rx (MHz)



	GSM1900	1850 ~ 1910	1930 ~ 1990
	WCDMA Band II	1850 ~ 1910	1930 ~ 1990
	LTE Band 2	1850 ~ 1910	1930 ~ 1990
EUT Accessory			
Adapter	Manufacturer: DongGuan AoHai Power Technology Co.Ltd. Model: A31A-050055U-US1		
Battery	Manufacturer: Shenzhen Aerospace Electronic.Co.Ltd Model: 178245411		
Earphone	Manufacturer: Baoshan Dahuahaihan Technology Co.,Ltd. Model: 3.5_balck_stereophony without mic_HTC		
Note: 1. The EUT is sent from the applicant to TA and the information of the EUT is declared by the applicant. 2. The customer claims that altice F4 and Sagetel Hinto lite are only different in model, and the others are the same.			

3. Applied Standards

According to the specifications of the manufacturer, it must comply with the requirements of the following standards:

Test standards:

FCC CFR 47 Part 24E (2021)

FCC CFR47 Part 2 (2021)

Reference standard:

ANSI C63.26-2015

KDB 971168 D01 Power Meas License Digital Systems v03r01

4. Test Configuration

Radiated measurements are performed by rotating the EUT in three different orthogonal test planes. EUT stand-up position (Z axis), lie-down position (X, Y axis). Receiver antenna polarization (horizontal and vertical), the worst emission was found in position (GSM/WCDMA for X axis, horizontal polarization; LTE for X axis, vertical polarization) and the worst case was recorded.

All mode and data rates and positions and RB size and modulations were investigated. Subsequently, only the worst case emissions are reported.

The following testing in GSM/WCDMA/LTE is set based on the maximum RF Output Power.

Test modes are chosen to be reported as the worst case configuration below:

Test items	Modes/Modulation	
	GSM 1900	WCDMA Band II
RF Power Output and Effective Isotropic Radiated Power	GSM GPRS EGPRS	RMC/AMR HSDPA/HSUPA HSPA+
Occupied Bandwidth	GSM GPRS(1Tx slot) EGPRS(1Tx slot)	RMC
Band Edge Compliance	GSM GPRS(1Tx slot) EGPRS(1Tx slot)	RMC
Peak-to-Average Power Ratio	GSM GPRS(1Tx slot) EGPRS(1Tx slot)	RMC
Frequency Stability	GSM GPRS(1Tx slot) EGPRS(1Tx slot)	RMC
Spurious Emissions at Antenna Terminals	GSM	RMC
Radiates Spurious Emission	GSM	RMC



Test modes are chosen to be reported as the worst case configuration below for LTE Band 2:

Test items	Bandwidth (MHz)						Modulation		RB			Test Channel		
	1.4	3	5	10	15	20	QPSK	16QAM	1	50%	100%	L	M	H
RF Power Output and Effective Isotropic Radiated Power	O	O	O	O	O	O	O	O	O	O	O	O	O	O
Occupied Bandwidth	O	O	O	O	O	O	O	O	-	-	O	O	O	O
Band Edge Compliance	O	O	O	O	O	O	O	O	O	-	O	O	-	O
Peak-to-Average Power Ratio	O	O	O	O	O	O	O	O	-	-	O	O	O	O
Frequency Stability	O	O	O	O	O	O	O	O	O	-	-	-	O	-
Spurious Emissions at Antenna Terminals	O	O	O	O	O	O	O	-	O	-	-	O	O	O
Radiates Spurious Emission	O	-	O	-	-	O	O	-	O	-	-	-	O	-
Note	1. The mark "O" means that this configuration is chosen for testing. 2. The mark "-" means that this configuration is not testing.													

5. Test Case

5.1.RF Power Output and Effective Isotropic Radiated Power

Ambient condition

Temperature	Relative humidity	Pressure
23°C ~25°C	45%~50%	101.5kPa

Methods of Measurement

During the process of the testing, The EUT was connected to the Base Station Simulator with a known loss. The EUT is controlled by the Base Station Simulator test set to ensure max power transmission with proper modulation.

ERP can then be calculated as follows:

$$\text{EIRP (dBm)} = \text{Output Power (dBm)} - \text{Losses (dB)} + \text{Antenna Gain (dBi)}$$

where:dBd refers to gain relative to an ideal dipole.

$$\text{EIRP (dBm)} = \text{ERP (dBm)} + 2.15 \text{ (dB.)}$$

Test Setup

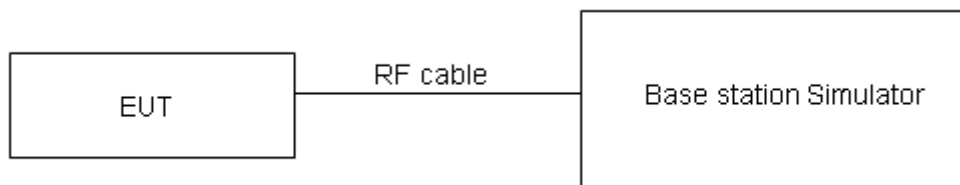

Limits

No specific RF power output requirements in part 2.1046.

Rule Part 24.232(c) Mobile and portable stations are limited to 2 watts EIRP.

Rule Part 24.232(e) Peak transmit power must be measured over any interval of continuous transmission using instrumentation calibrated in terms of an rms-equivalent voltage.

Limit	$\leq 2 \text{ W}$ (33 dBm)
-------	-----------------------------

Measurement Uncertainty

The assessed measurement uncertainty to ensure 95% confidence level for the normal distribution is with the coverage factor $k = 2$, $U = 0.4 \text{ dB}$ for RF power output, $k = 2$, $U = 1.19 \text{ dB}$ for EIRP.

Test Results

Refer to the section 6.1 of this report for test data.

5.2.Occupied Bandwidth

Ambient condition

Temperature	Relative humidity	Pressure
23°C ~25°C	45%~50%	101.5kPa

Method of Measurement

The EUT was connected to Spectrum Analyzer and Base Station Simulator via power Splitter. The occupied bandwidth is measured using spectrum analyzer.

RBW is set to $\geq 1\%EBW$, VBW is set to 3x RBW.

99% power and -26dBc occupied bandwidths are recorded. Spectrum analyzer plots are included on the following pages.

Test Setup

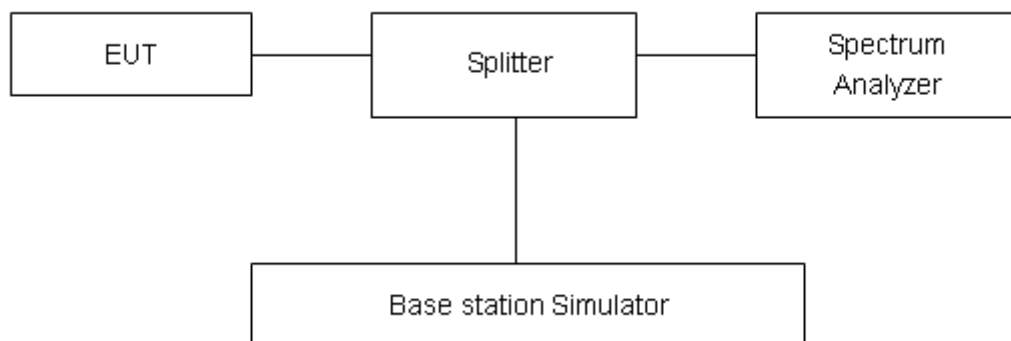

Limits

No specific occupied bandwidth requirements in part 2.1049.

Measurement Uncertainty

The assessed measurement uncertainty to ensure 95% confidence level for the normal distribution is with the coverage factor $k = 2$, $U = 624\text{Hz}$.

Test Results

Refer to the section 6.2 of this report for test data.

5.3. Band Edge Compliance

Ambient condition

Temperature	Relative humidity	Pressure
23°C ~25°C	45%~50%	101.5kPa

Method of Measurement

The EUT was connected to Spectrum Analyzer and Base Station Simulator via power Splitter. The band edge of the lowest and highest channels were measured. The Average detector is used and RBW is set to $\geq 1\%EBW$, VBW is set to 3x RBW.

Spectrum analyzer plots are included on the following pages.

Test Setup

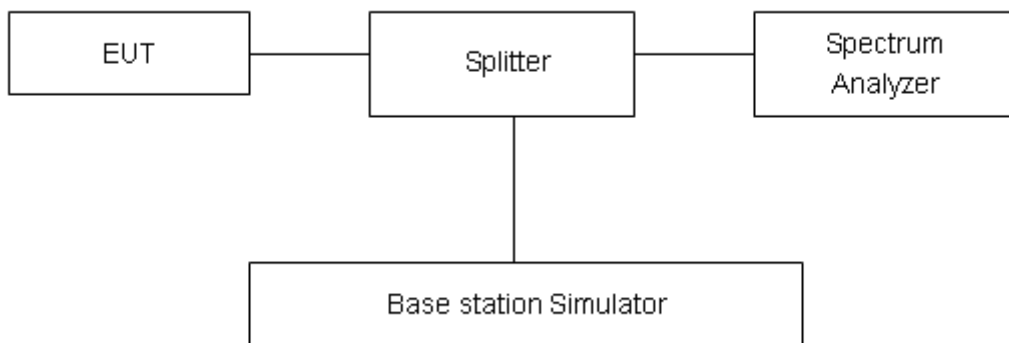

Limits

Rule Part 24.238(a) specifies that “on any frequency outside a licensee's frequency block, the power of any emission shall be attenuated below the transmitter power (P) by at least $43 + 10 \log_{10} (P)$ dB.”

Limit	-13 dBm
-------	---------

Measurement Uncertainty

The assessed measurement uncertainty to ensure 95% confidence level for the normal distribution is with the coverage factor $k = 1.96$, $U=0.684dB$.

Test Results

Refer to the section 6.3 of this report for test data.

5.4. Peak-to-Average Power Ratio (PAPR)

Ambient condition

Temperature	Relative humidity	Pressure
23°C ~25°C	45%~50%	101.5kPa

Methods of Measurement

Measure the total peak power and record as PPK. And measure the total average power and record as PAvg. Both the peak and average power levels must be expressed in the same logarithmic units (e.g., dBm). Determine the PAPR from:

$$PAPR (dB) = PPK (dBm) - PAvg (dBm).$$

Test Setup

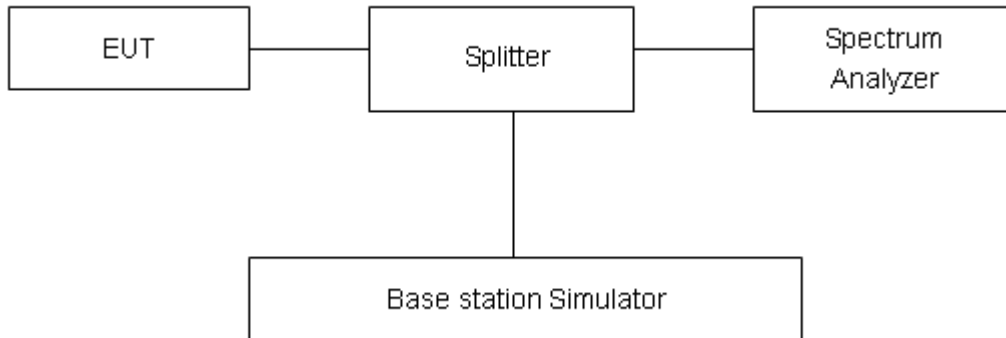

Limits

In measuring transmissions in this band using an average power technique, the peak-to-average ratio (PAR) of the transmission may not exceed 13 dB in 24.232(d).

Measurement Uncertainty

The assessed measurement uncertainty to ensure 95% confidence level for the normal distribution is with the coverage factor $k = 2$, $U = 0.4$ dB.

Test Results

Refer to the section 6.4 of this report for test data.

5.5.Frequency Stability

Ambient condition

Temperature	Relative humidity	Pressure
23°C ~25°C	45%~50%	101.5kPa

Method of Measurement

Frequency Stability (Temperature Variation)

The temperature inside the climate chamber is varied from -30°C to +50°C in 10°C step size,

(1) With all power removed, the temperature was decreased to 0°C and permitted to stabilize for three hours.

(2) Measure the carrier frequency with the test equipment in a “call mode”. These measurements should be made within 1 minute of powering up the mobile station, to prevent significant self warming.

(3) Repeat the above measurements at 10°C increments from -30°C to +50°C. Allow at least 1.5 hours at each temperature, un-powered, before making measurements.

Frequency Stability (Voltage Variation)

The frequency stability shall be measured with variation of primary supply voltage as follows:

Primary Supply Voltage: The primary supply voltage is varied from 85% to 115% of the nominal value for non hand-carried battery and AC powered equipment. For hand-carried, battery-powered equipment, primary supply voltage is reduced to the battery operating end point which shall be specified by the manufacturer.

This transceiver is specified to operate with an input voltage of between 3.6 V and 4.2V, with a nominal voltage of 3.8V.

Test setup

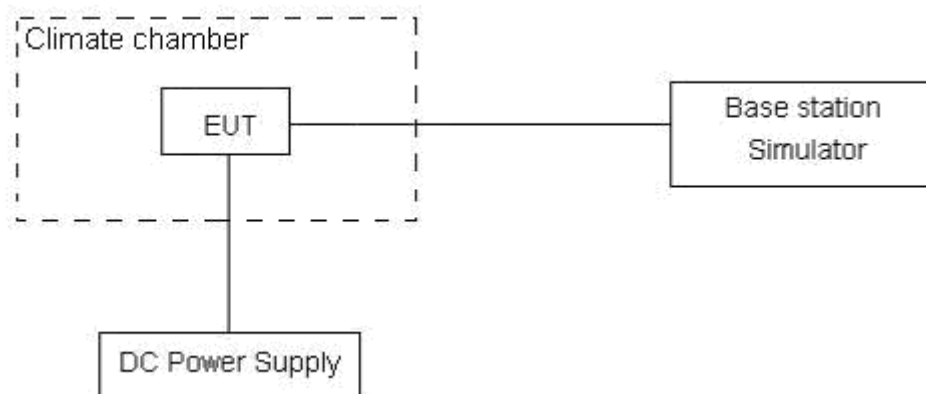



Limits

The frequency stability shall be sufficient to ensure that the fundamental emission stays within the authorized frequency block

Measurement Uncertainty

The assessed measurement uncertainty to ensure 99.75% confidence level for the normal distribution is with the coverage factor $k = 3$, $U = 0.01\text{ppm}$.

Test Results

Refer to the section 6.5 of this report for test data.

5.6. Spurious Emissions at Antenna Terminals

Ambient condition

Temperature	Relative humidity	Pressure
23°C ~25°C	45%~50%	101.5kPa

Method of Measurement

The EUT was connected to Spectrum Analyzer and Base Station Simulator via power Splitter. The measurement is carried out using a spectrum analyzer. The spectrum analyzer scans from 9kHz to the 10th harmonic of the carrier. The peak detector is used.

RBW is set to 100kHz, VBW is set to 300kHz for 30MHz~1GHz

RBW is set to 1MHz, VBW is set to 3MHz for above 1GHz, Sweep is set to ATUO.

RBW is set to 1 kHz (0.009MHz~ 0.15 MHz),

RBW is set to 10 kHz (0.15 MHz~ 30 MHz)

RBW is set to 100 kHz (30MHz~1000 MHz)

RBW is set to 1000 kHz (above 1000MHz)

The modulation mode and RB allocation refer to section 5.1, using the maximum output power configuration.

Test setup

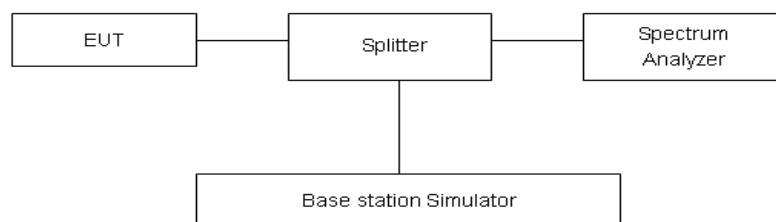

Limits

Rule Part 24.238(a) specifies that “on any frequency outside a licensee’s frequency block, the power of any emission shall be attenuated below the transmitter power (P) by at least $43 + 10 \log_{10}(P)$ dB.”

Limit	-13 dBm

Measurement Uncertainty

The assessed measurement uncertainty to ensure 99.75% confidence level for the normal distribution is with the coverage factor $k = 1.96$.

Frequency	Uncertainty
9kHz-1GHz	0.684 dB
1GHz-20GHz	1.407 dB

Test Results

Refer to the section 6.6 of this report for test data.

5.7. Radiates Spurious Emission

Ambient condition

Temperature	Relative humidity	Pressure
23°C ~25°C	45%~50%	101.5kPa

Method of Measurement

1. The testing follows FCC KDB 971168 v03r01 Section 5.8 and ANSI C63.26 (2015).
2. Below 1GHz: The EUT is placed on a turntable 0.8 meters above the ground in the chamber, 3 meter away from the antenna. The maximal emission value is acquired by adjusting the antenna height, polarisation and turntable azimuth. Normally, the height range of antenna is 1 m to 4 m, the azimuth range of turntable is 0° to 360°, and the receive antenna has two polarizations Vertical (V) and Horizontal (H). Above 1GHz: (Note: the FCC's permission to use 1.5m as an alternative per TCBC Conf call of Dec. 2, 2014.) The EUT is placed on a turntable 1.5 meters above the ground in the chamber, 3 meter away from the antenna. The maximal emission value is acquired by adjusting the antenna height, polarisation and turntable azimuth. Normally, the height range of antenna is 1 m to 4 m, the azimuth range of turntable is 0° to 360°, and the receive antenna has two polarizations Vertical (V) and Horizontal (H).
3. A loop antenna, A log-periodic antenna or horn antenna shall be substituted in place of the EUT. The log-periodic antenna will be driven by a signal generator and the level will be adjusted till the same power value on the spectrum analyzer or receiver. The level of the spurious emissions can be calculated through the level of the signal generator, cable loss, the gain of the substitution antenna and the reading of the spectrum analyzer or receiver.
4. The EUT is then put into continuously transmitting mode at its maximum power level during the test. Set Test Receiver or Spectrum RBW=1MHz, VBW=3MHz, and the maximum value of the receiver should be recorded as (Pr).
5. The EUT shall be replaced by a substitution antenna. In the chamber, an substitution antenna for the frequency band of interest is placed at the reference point of the chamber. An RF Signal source for the frequency band of interest is connected to the substitution antenna with a cable that has been constructed to not interfere with the radiation pattern of the antenna. A power (PMea) is applied to the input of the substitution antenna, and adjust the level of the signal generator output until the value of the receiver reach the previously recorded (Pr). The power of signal source (PMea) is recorded. The test should be performed by rotating the test item and adjusting the receiving antenna polarization.
6. A amplifier should be connected to the Signal Source output port. And the cable should be connect between the Amplifier and the Substitution Antenna. The cable loss (Pcl) ,the Substitution Antenna Gain (Ga) and the Amplifier Gain (PAg) should be recorded after test.
7. The measurement results are obtained as described below:
$$\text{Power(EIRP)} = \text{PMea} - \text{PAg} - \text{Pcl} + \text{Ga}$$

The measurement results are amend as described below:
$$\text{Power(EIRP)} = \text{PMea} - \text{Pcl} + \text{Ga}$$
8. This value is EIRP since the measurement is calibrated using an antenna of known gain (2.15 dB) and known input power. ERP can be calculated from EIRP by subtracting the gain of the dipole, ERP

= EIRP-2.15dB.

The modulation mode and RB allocation refer to section 5.1, using the maximum output power configuration.

Test setup

9KHz ~ 30MHz

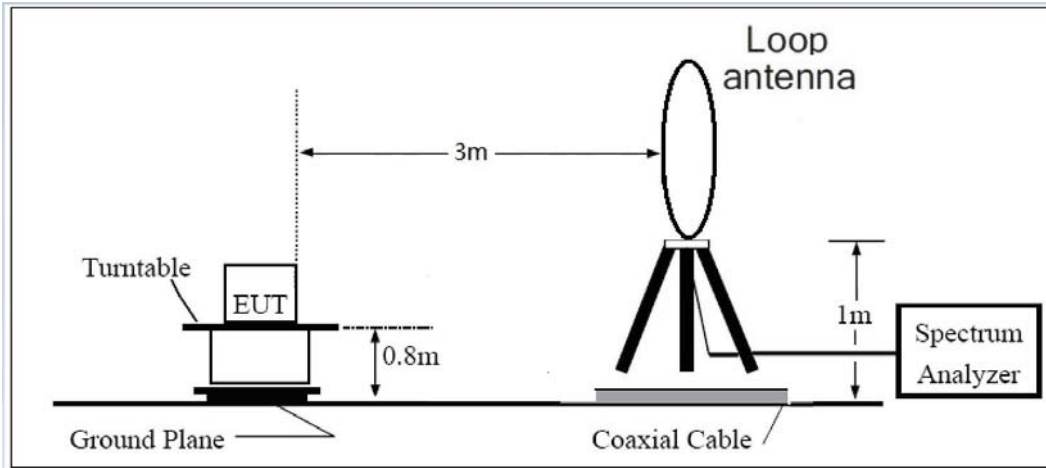

30MHz ~ 1GHz

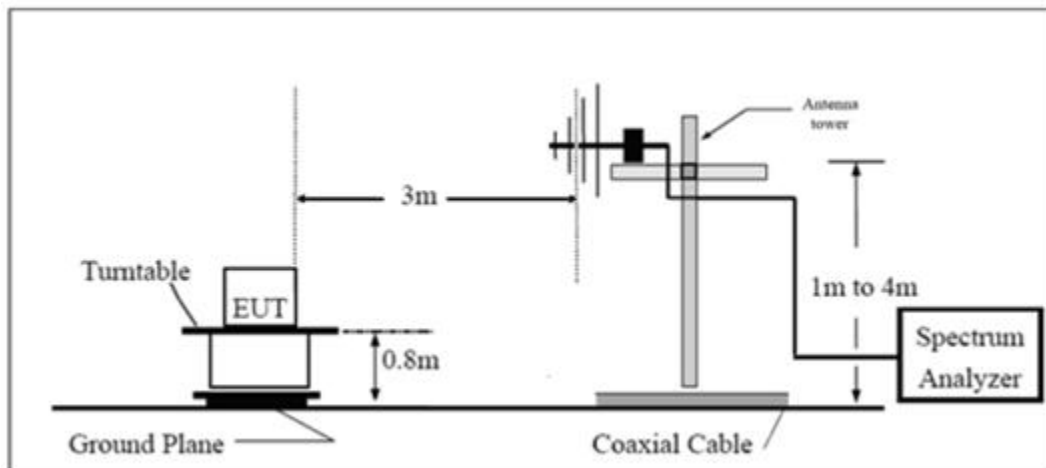

Above 1GHz

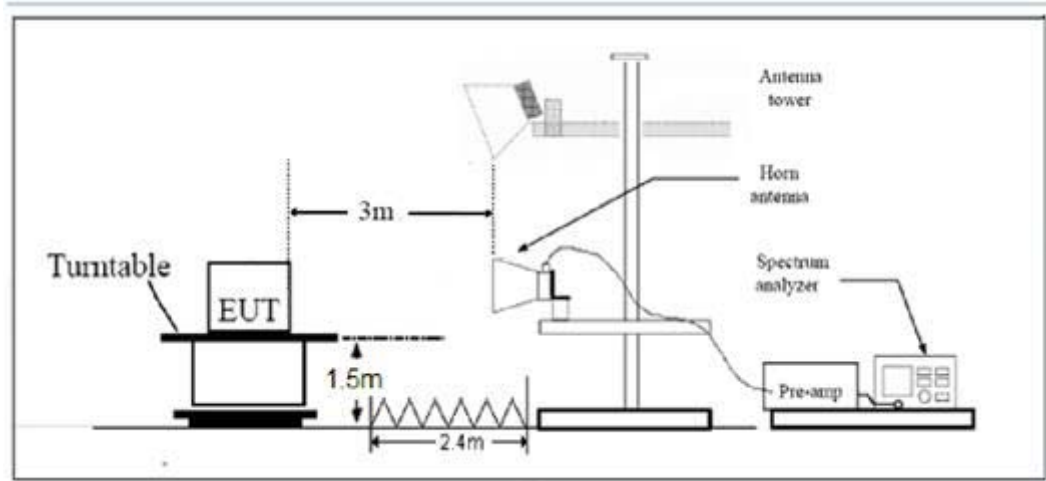

Note: Area side: 2.4mX3.6m

Limits

Rule Part 24.238(a) specifies that “on any frequency outside a licensee's frequency block, the power of any emission shall be attenuated below the transmitter power (P) by at least $43 + 10 \log_{10} (P)$ dB.”

Limit	-13 dBm
-------	---------

Measurement Uncertainty

The assessed measurement uncertainty to ensure 95% confidence level for the normal distribution is with the coverage factor $k = 1.96$, $U = 3.55$ dB.

Test Results

Refer to the section 6.7 of this report for test data.

6. Test Results

6.1.RF Power Output and Effective Isotropic Radiated Power

GSM 1900		Maximum Output Power (dBm)			EIRP (dBm)		
		Channel 512	Channel 661	Channel 810	Channel 512	Channel 661	Channel 810
		1850.2 (MHz)	1880 (MHz)	1909.8 (MHz)	1850.2 (MHz)	1880 (MHz)	1909.8 (MHz)
GSM(GMSK)	Results	27.40	27.40	27.35	28.90	28.90	28.85
GPRS (GMSK)	1TXslot	27.37	27.42	27.31	28.87	28.92	28.81
	2TXslots	26.21	26.01	25.79	27.71	27.51	27.29
	3TXslots	24.10	23.90	23.65	25.60	25.40	25.15
	4TXslots	22.22	21.98	21.66	23.72	23.48	23.16
EGPRS (8PSK)	1TXslot	24.41	24.68	24.31	25.91	26.18	25.81
	2TXslots	23.08	23.41	22.81	24.58	24.91	24.31
	3TXslots	20.90	21.26	20.56	22.40	22.76	22.06
	4TXslots	18.77	19.20	18.40	20.27	20.70	19.90

WCDMA Band II		Maximum Output Power (dBm)			EIRP (dBm)		
		Channel 9262	Channel 9400	Channel 9538	Channel 9262	Channel 9400	Channel 9538
		1852.4 (MHz)	1880 (MHz)	1907.6 (MHz)	1852.4 (MHz)	1880 (MHz)	1907.6 (MHz)
RMC		20.65	20.73	20.82	21.65	21.73	21.82
AMR		20.71	20.66	20.68	21.71	21.66	21.68
HSDPA	Sub - Test 1	21.11	21.19	21.15	22.11	22.19	22.15
	Sub - Test 2	20.37	21.00	20.94	21.37	22.00	21.94
	Sub - Test 3	19.42	20.03	19.94	20.42	21.03	20.94
	Sub - Test 4	18.70	18.66	19.02	19.70	19.66	20.02
HSUPA	Sub - Test 1	17.49	17.86	17.92	18.49	18.86	18.92
	Sub - Test 2	18.25	17.69	17.72	19.25	18.69	18.72
	Sub - Test 3	17.73	18.16	18.16	18.73	19.16	19.16
	Sub - Test 4	17.76	18.20	18.22	18.76	19.20	19.22
	Sub - Test 5	20.03	20.22	20.13	21.03	21.22	21.13



LTE Band 2				Maximum Output Power(dBm)			EIRP (dBm)		
BW	Modulation	RB size	RB offset	Channel/Frequency(MHz)					
				18607/1850.7	18900/1880	19193/1909.3	18607/1850.7	18900/1880	19193/1909.3
1.4MHz	QPSK	1	0	21.18	21.39	21.41	20.18	20.39	20.41
		1	2	21.25	21.29	21.35	20.25	20.29	20.35
		1	5	21.18	21.28	21.39	20.18	20.28	20.39
		3	0	21.00	21.13	21.06	20.00	20.13	20.06
		3	2	20.96	21.02	21.18	19.96	20.02	20.18
		3	3	21.17	20.98	21.15	20.17	19.98	20.15
		6	0	20.12	20.11	20.18	19.12	19.11	19.18
	16QAM	1	0	19.81	19.73	19.81	18.81	18.73	18.81
		1	2	19.64	19.60	19.64	18.64	18.60	18.64
		1	5	20.01	19.91	19.92	19.01	18.91	18.92
		3	0	20.37	20.20	20.27	19.37	19.20	19.27
		3	2	20.29	20.14	20.20	19.29	19.14	19.20
		3	3	20.41	20.31	20.31	19.41	19.31	19.31
		6	0	19.32	19.29	19.28	18.32	18.29	18.28
BW	Modulation	RB size	RB offset	Channel/Frequency(MHz)					
				18615/1851.5	18900/1880	19185/1908.5	18615/1851.5	18900/1880	19185/1908.5
3MHz	QPSK	1	0	21.15	21.34	21.38	20.15	20.34	20.38
		1	7	21.21	21.28	21.35	20.21	20.28	20.35
		1	14	21.15	21.26	21.35	20.15	20.26	20.35
		8	0	20.05	20.16	20.12	19.05	19.16	19.12
		8	4	20.04	20.04	20.22	19.04	19.04	19.22
		8	7	20.21	20.03	20.18	19.21	19.03	19.18
		15	0	20.11	20.07	20.14	19.11	19.07	19.14
	16QAM	1	0	19.80	19.68	19.76	18.80	18.68	18.76
		1	7	19.63	19.57	19.62	18.63	18.57	18.62
		1	14	19.98	19.88	19.89	18.98	18.88	18.89
		8	0	19.43	19.28	19.34	18.43	18.28	18.34
		8	4	19.33	19.19	19.24	18.33	18.19	18.24
		8	7	19.46	19.34	19.37	18.46	18.34	18.37
		15	0	19.31	19.25	19.23	18.31	18.25	18.23
BW	Modulation	RB size	RB offset	Channel/Frequency(MHz)					
				18625/1852.5	18900/1880	19175/1907.5	18625/1852.5	18900/1880	19175/1907.5
5MHz	QPSK	1	0	21.13	21.27	21.36	20.13	20.27	20.36
		1	13	21.21	21.28	21.34	20.21	20.28	20.34
		1	24	21.12	21.24	21.31	20.12	20.24	20.31



		12	0	20.03	20.12	20.09	19.03	19.12	19.09
		12	6	20.02	20.00	20.19	19.02	19.00	19.19
		12	13	20.17	19.99	20.15	19.17	18.99	19.15
		25	0	20.10	20.00	20.09	19.10	19.00	19.09
	16QAM	1	0	19.79	19.65	19.71	18.79	18.65	18.71
		1	13	19.62	19.56	19.59	18.62	18.56	18.59
		1	24	19.96	19.83	19.87	18.96	18.83	18.87
		12	0	19.40	19.27	19.32	18.40	18.27	18.32
		12	6	19.29	19.16	19.20	18.29	18.16	18.20
		12	13	19.44	19.30	19.34	18.44	18.30	18.34
25	0	19.29	19.21	19.20	18.29	18.21	18.20		
BW	Modulation	RB size	RB offset	Channel/Frequency(MHz)					
				18650/1855	18900/1880	19150/1905	18650/1855	18900/1880	19150/1905
10MHz	QPSK	1	0	21.16	21.31	21.39	20.16	20.31	20.39
		1	25	21.22	21.32	21.36	20.22	20.32	20.36
		1	49	21.14	21.25	21.34	20.14	20.25	20.34
		25	0	20.06	20.17	20.13	19.06	19.17	19.13
		25	13	20.04	20.04	20.22	19.04	19.04	19.22
		25	25	20.20	20.04	20.19	19.20	19.04	19.19
		50	0	20.13	20.05	20.13	19.13	19.05	19.13
	16QAM	1	0	19.82	19.69	19.76	18.82	18.69	18.76
		1	25	19.65	19.58	19.63	18.65	18.58	18.63
		1	49	19.99	19.86	19.89	18.99	18.86	18.89
		25	0	19.43	19.31	19.35	18.43	18.31	18.35
		25	13	19.32	19.18	19.23	18.32	18.18	18.23
		25	25	19.47	19.35	19.38	18.47	18.35	18.38
		50	0	19.31	19.25	19.23	18.31	18.25	18.23
BW	Modulation	RB size	RB offset	Channel/Frequency(MHz)					
				18675/1857.5	18900/1880	19125/1902.5	18675/1857.5	18900/1880	19125/1902.5
15MHz	QPSK	1	0	21.12	21.23	21.34	20.12	20.23	20.34
		1	38	21.19	21.27	21.31	20.19	20.27	20.31
		1	74	21.09	21.19	21.27	20.09	20.19	20.27
		36	0	20.01	20.08	20.06	19.01	19.08	19.06
		36	18	19.99	19.95	20.15	18.99	18.95	19.15
		36	39	20.14	19.96	20.11	19.14	18.96	19.11
		75	0	20.08	19.96	20.04	19.08	18.96	19.04
	16QAM	1	0	19.77	19.63	19.69	18.77	18.63	18.69
		1	38	19.60	19.53	19.57	18.60	18.53	18.57
		1	74	19.94	19.79	19.84	18.94	18.79	18.84
		36	0	19.37	19.25	19.29	18.37	18.25	18.29
		36	18	19.26	19.11	19.16	18.26	18.11	18.16



BW	Modulation	RB size	RB offset	Channel/Frequency(MHz)					
				18700/ 1860	18900/ 1880	19100/ 1900	18700/ 1860	18900/ 1880	19100/ 1900
						36	39	19.42	19.26
		75	0	19.26	19.16	19.16	18.26	18.16	18.16
20MHz	QPSK	1	0	21.09	21.19	21.31	20.09	20.19	20.31
		1	50	21.18	21.23	21.29	20.18	20.23	20.29
		1	99	21.07	21.18	21.24	20.07	20.18	20.24
		50	0	19.98	20.03	20.02	18.98	19.03	19.02
		50	25	19.97	19.91	20.12	18.97	18.91	19.12
		50	50	20.11	19.91	20.07	19.11	18.91	19.07
		100	0	20.05	19.91	20.00	19.05	18.91	19.00
	16QAM	1	0	19.74	19.59	19.64	18.74	18.59	18.64
		1	50	19.57	19.51	19.53	18.57	18.51	18.53
		1	99	19.91	19.76	19.82	18.91	18.76	18.82
		50	0	19.34	19.21	19.26	18.34	18.21	18.26
		50	25	19.23	19.09	19.13	18.23	18.09	18.13
		50	50	19.39	19.21	19.27	18.39	18.21	18.27
		100	0	19.24	19.12	19.13	18.24	18.12	18.13

6.2.Occupied Bandwidth

Mode	Channel	Frequency (MHz)	99% Power Bandwidth (MHz)	-26dBc Bandwidth(MHz)
GSM 1900 (GMSK)	512	1850.2	0.242	0.301
	661	1880.0	0.241	0.300
	810	1909.8	0.239	0.300
GPRS 1900 (GMSK)	512	1850.2	0.243	0.304
	661	1880.0	0.245	0.305
	810	1909.8	0.248	0.311
EGPRS 1900 (8PSK)	512	1850.2	0.245	0.308
	661	1880.0	0.247	0.311
	810	1909.8	0.247	0.313
WCDMA Band II (RMC)	9262	1852.4	4.162	4.659
	9400	1880	4.145	4.650
	9538	1907.6	4.151	4.645

LTE Band 2						
RB	Modulation	Bandwidth (MHz)	Channel	Frequency (MHz)	99% Power Bandwidth(MHz)	-26dBc Bandwidth(MHz)
100%	QPSK	1.4	18607	1850.7	1.100	1.241
			18900	1880.0	1.099	1.253
			19193	1909.3	1.095	1.258
		3	18615	1851.5	2.723	3.046
			18900	1880	2.723	3.022
			19185	1908.5	2.722	3.042
		5	18625	1852.5	4.518	5.006
			18900	1880	4.518	5.007
			19175	1907.5	4.518	4.996
		10	18650	1855	8.979	9.790
			18900	1880	9.017	9.825
			19150	1905	8.964	9.876
		15	18675	1857.5	13.459	14.874
			18900	1880	13.474	14.614
			19125	1902.5	13.452	14.930
		20	18700	1860	17.938	19.574
			18900	1880	17.997	19.606



			19100	1900	18.031	19.576
	16QAM	1.4	18607	1850.7	1.104	1.250
			18900	1880.0	1.102	1.247
			19193	1909.3	1.092	1.247
		3	18615	1851.5	2.703	3.042
			18900	1880	2.711	3.027
			19185	1908.5	2.724	3.044
		5	18625	1852.5	4.517	4.970
			18900	1880	4.503	4.975
			19175	1907.5	4.519	4.981
		10	18650	1855	9.001	9.884
			18900	1880	8.998	9.909
			19150	1905	8.961	9.842
		15	18675	1857.5	13.454	14.815
			18900	1880	13.519	14.851
			19125	1902.5	13.468	14.901
		20	18700	1860	18.061	19.671
			18900	1880	18.047	19.745
			19100	1900	18.008	19.761

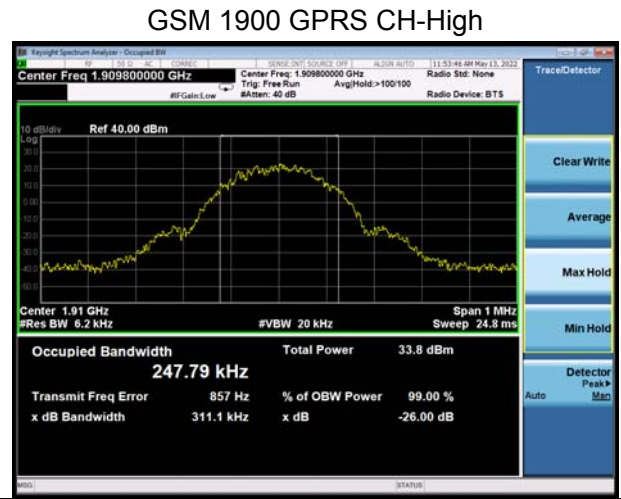
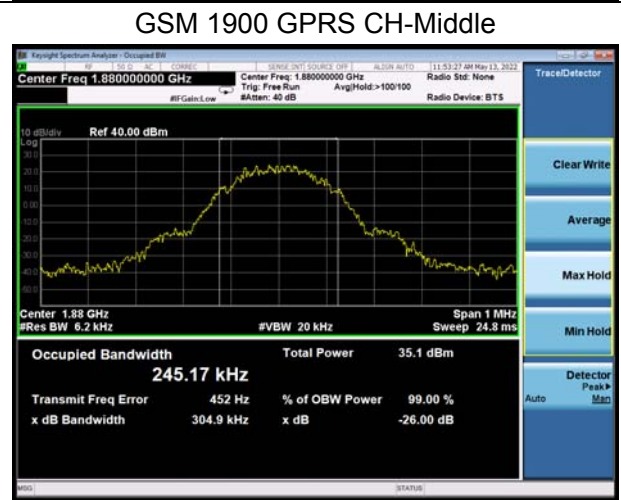
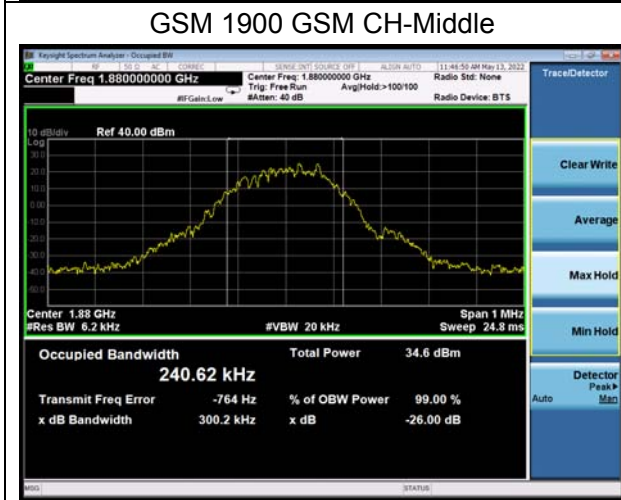
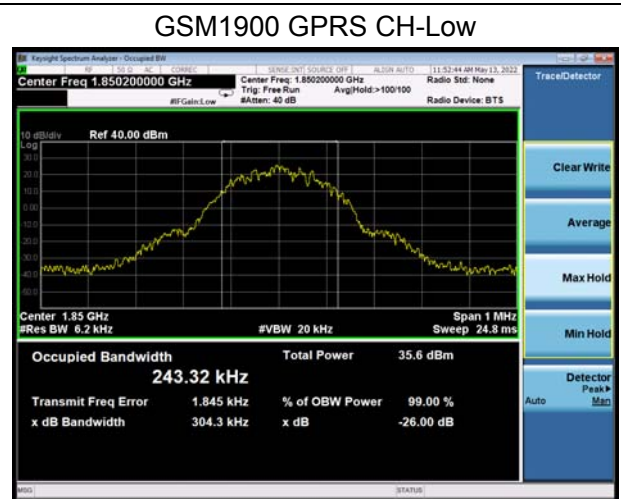
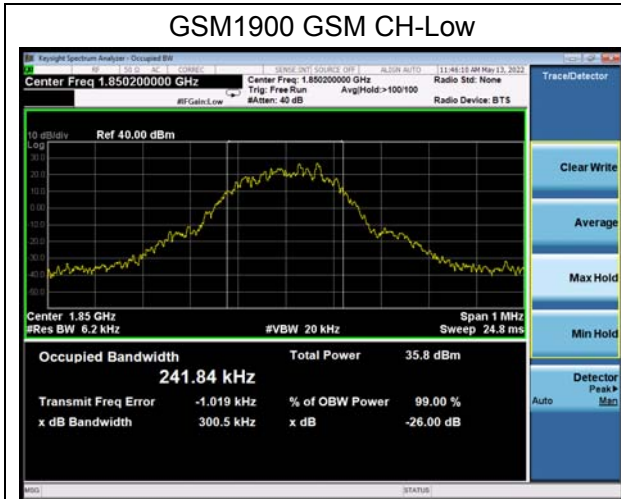

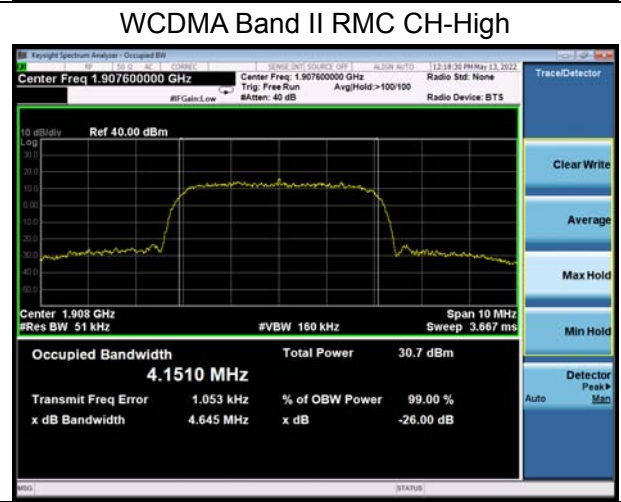
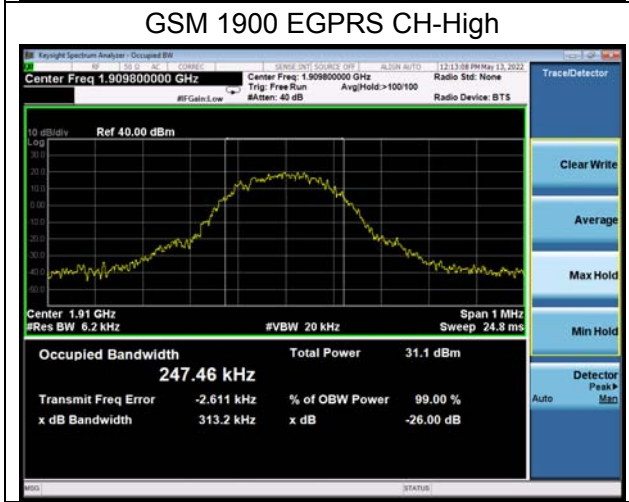
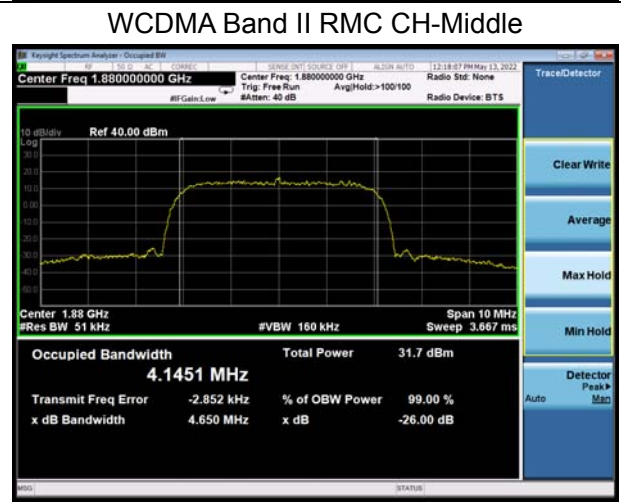
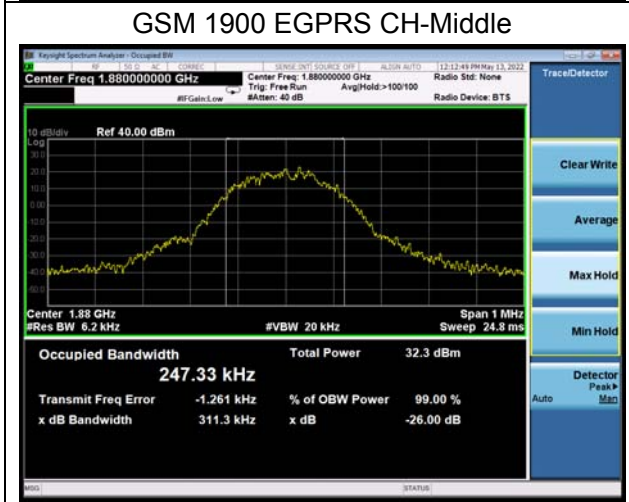
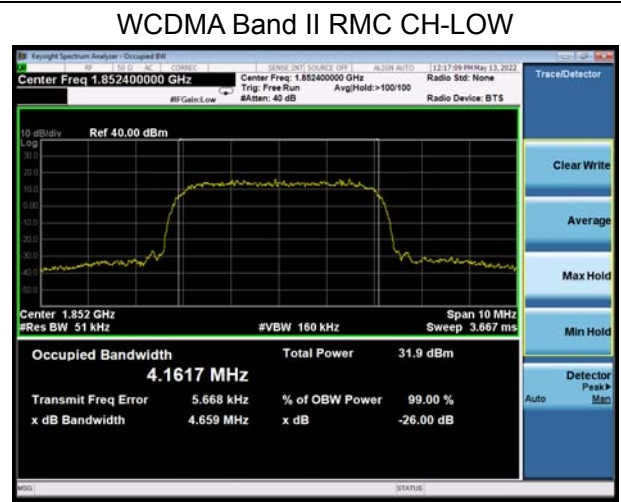
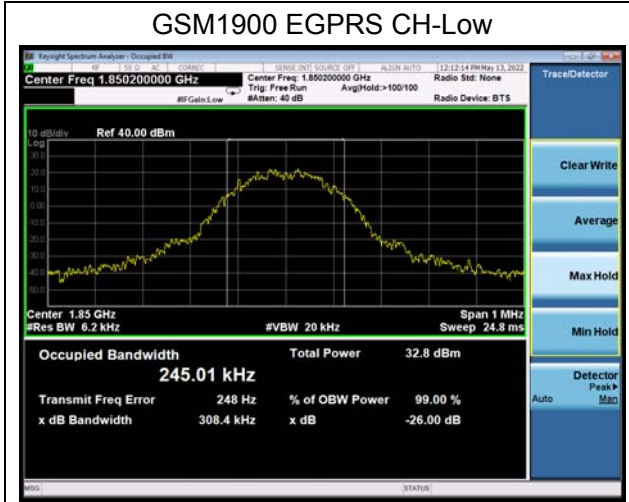



LTE Band 2 1.4MHz QPSK CH-Low

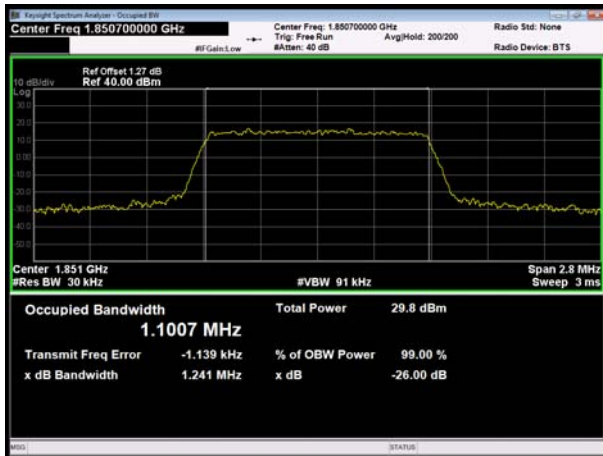

LTE Band 2 3MHz QPSK CH-Low

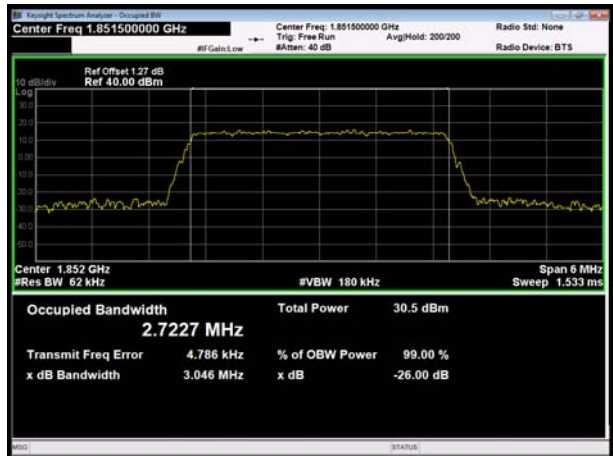

LTE Band 2 1.4MHz QPSK CH-Middle

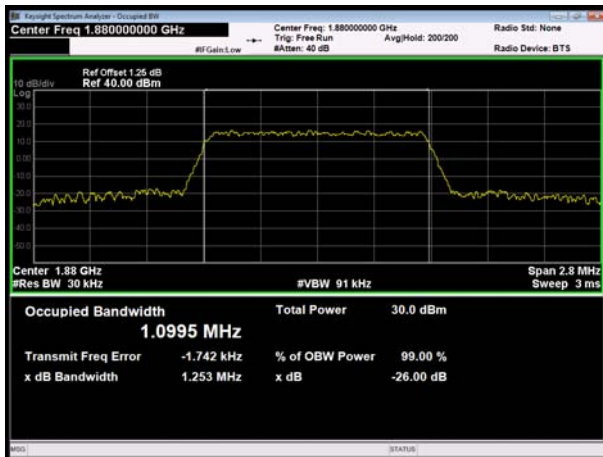

LTE Band 2 3MHz QPSK CH-Middle

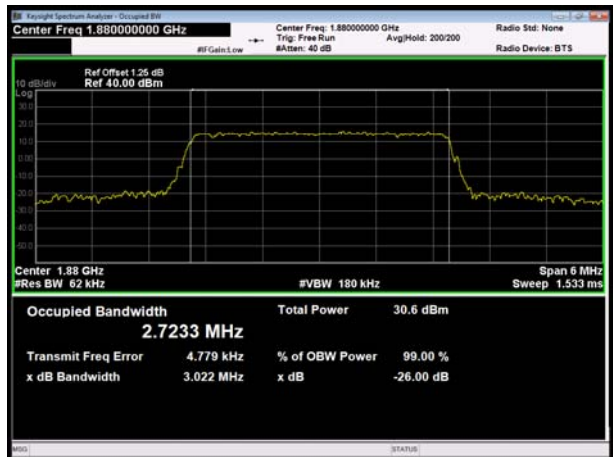

LTE Band 2 1.4MHz QPSK CH-High

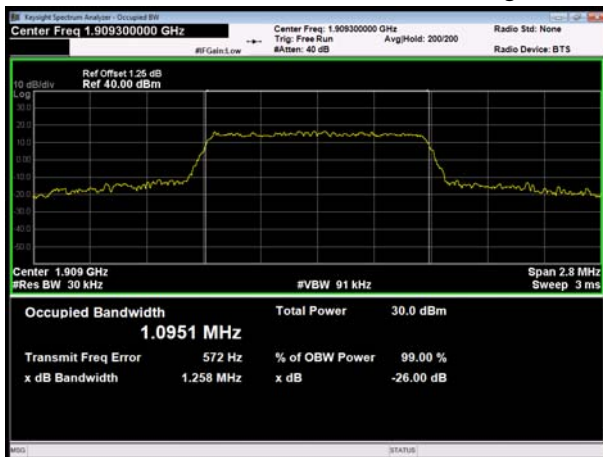

LTE Band 2 3MHz QPSK CH-High

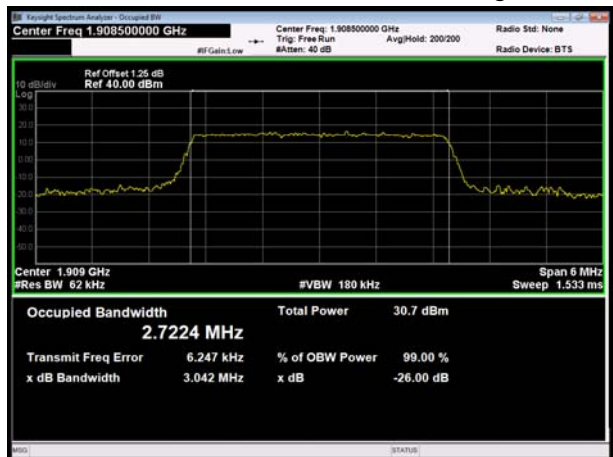



LTE Band 2 5MHz QPSK CH-Low

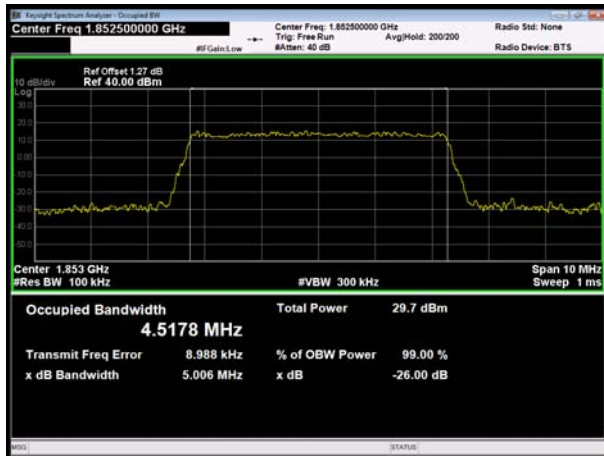

LTE Band 2 10MHz QPSK CH-Low

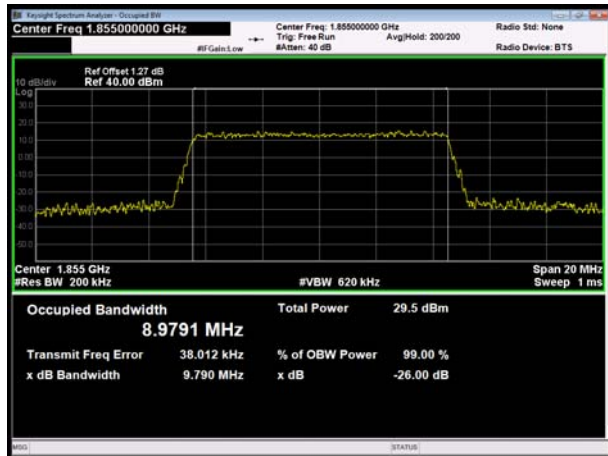

LTE Band 2 5MHz QPSK CH-Middle

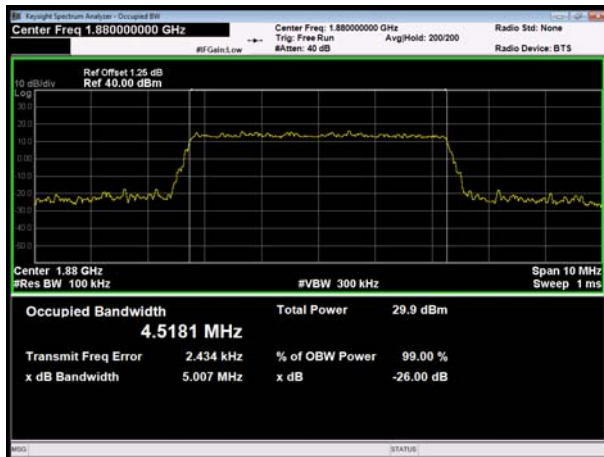

LTE Band 2 10MHz QPSK CH-Middle

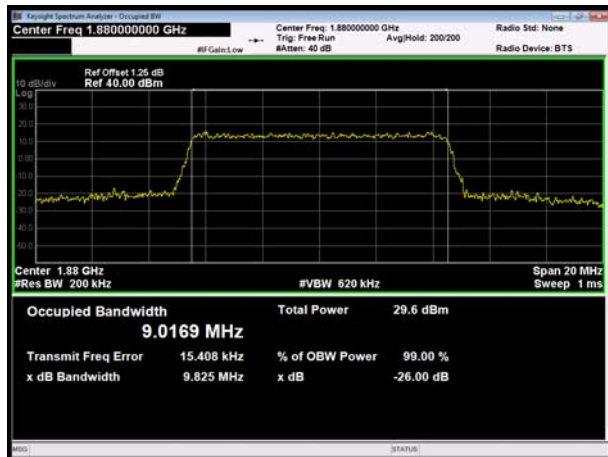

LTE Band 2 5MHz QPSK CH-High

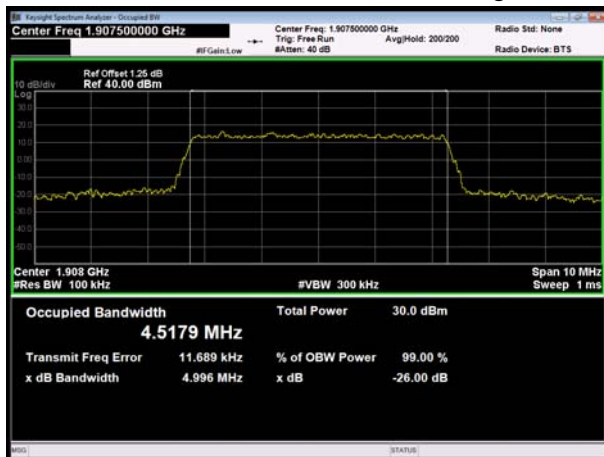

LTE Band 2 10MHz QPSK CH-High

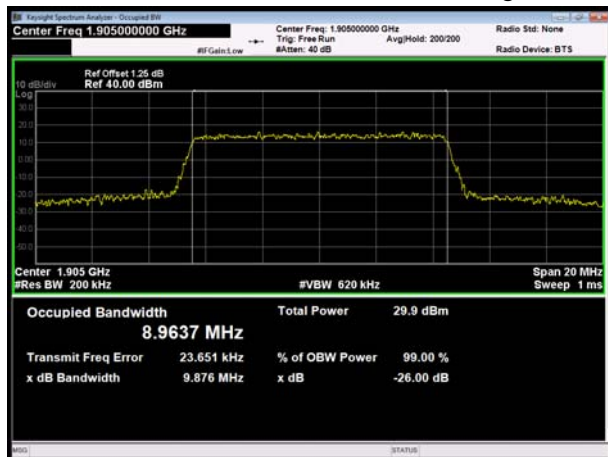

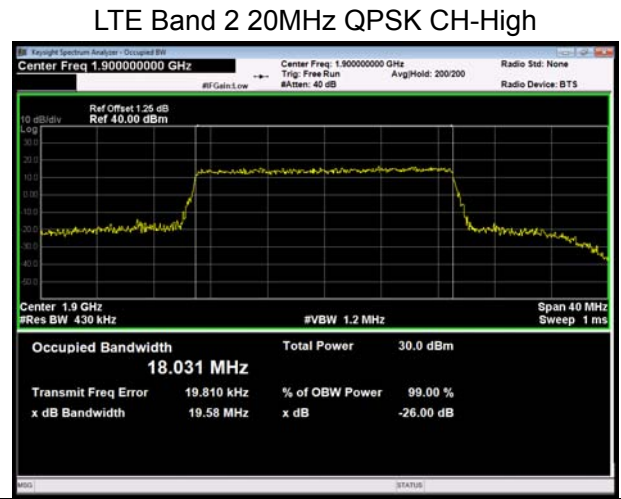
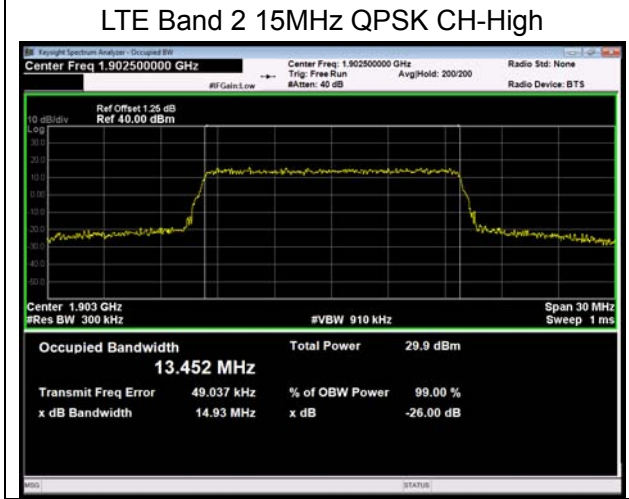
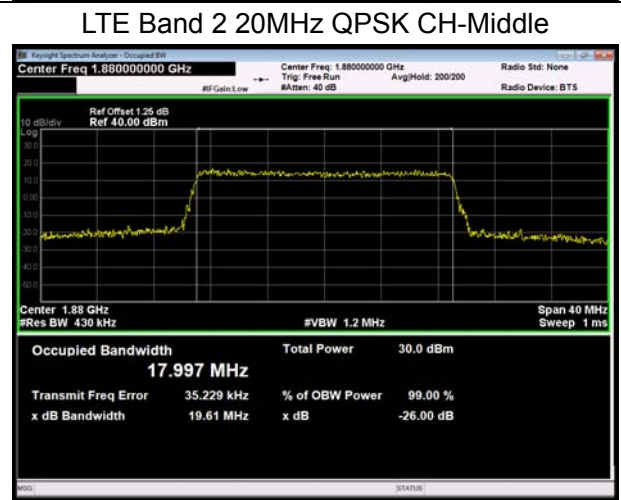
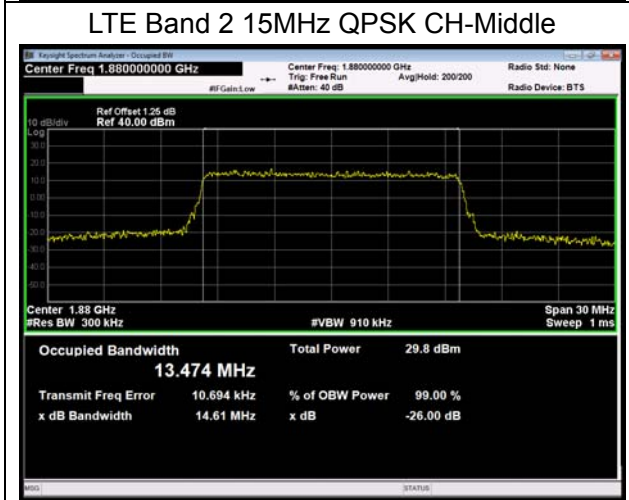
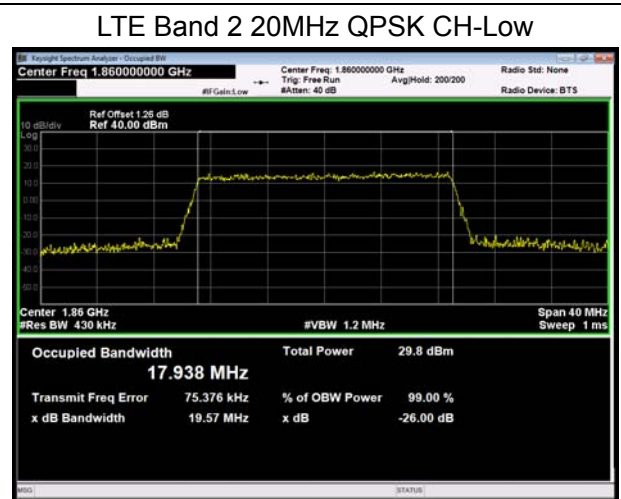
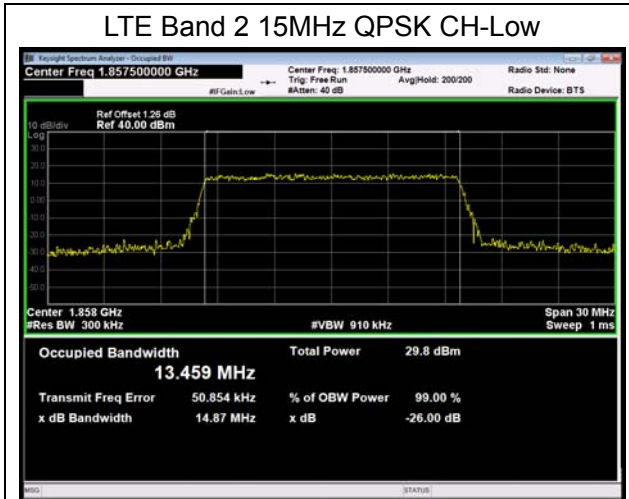



LTE Band 2 1.4MHz 16QAM CH-Low

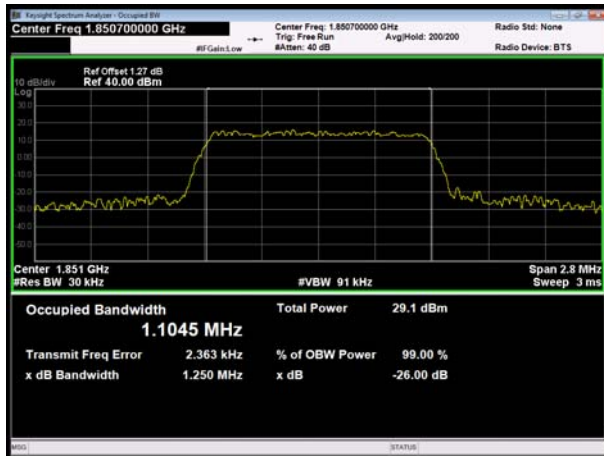

LTE Band 2 3MHz 16QAM CH-Low

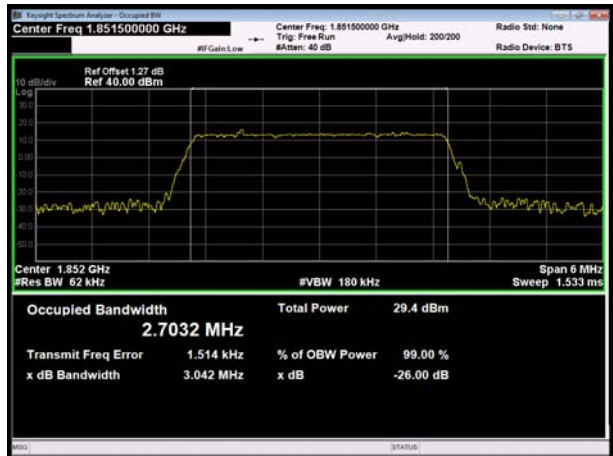

LTE Band 2 1.4MHz 16QAM CH-Middle

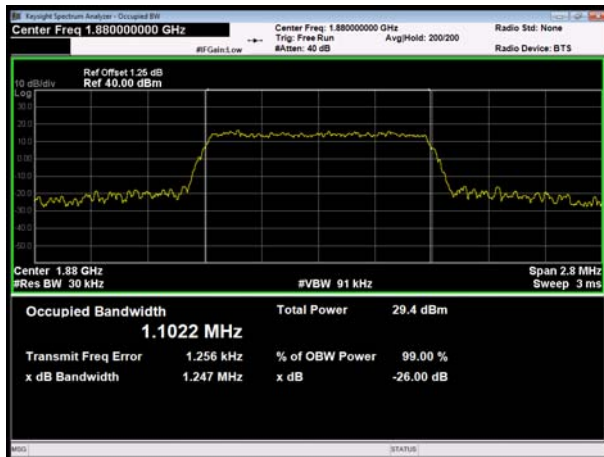

LTE Band 2 3MHz 16QAM CH-Middle

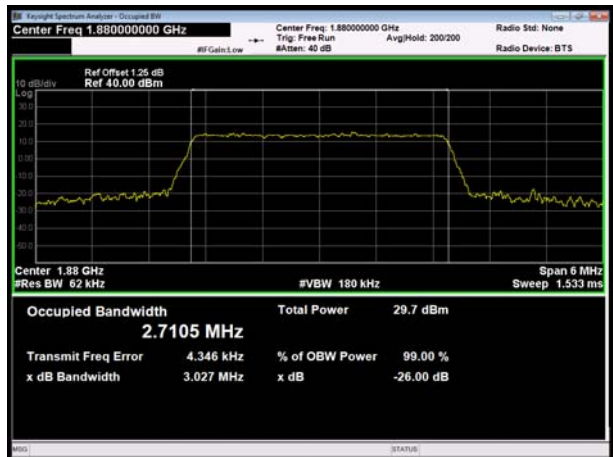

LTE Band 2 1.4MHz 16QAM CH-High



LTE Band 2 3MHz 16QAM CH-High



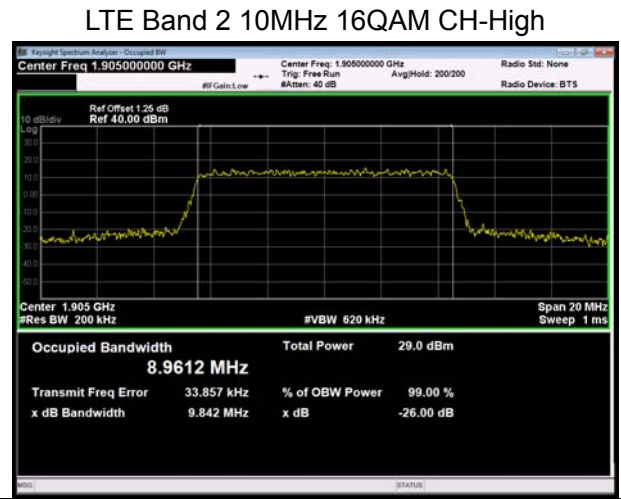
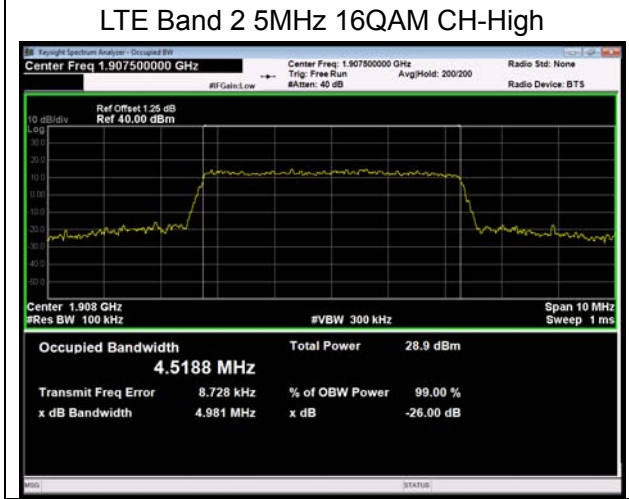
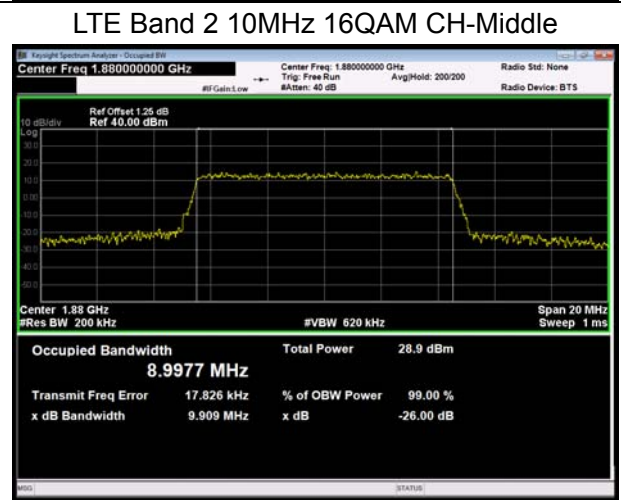
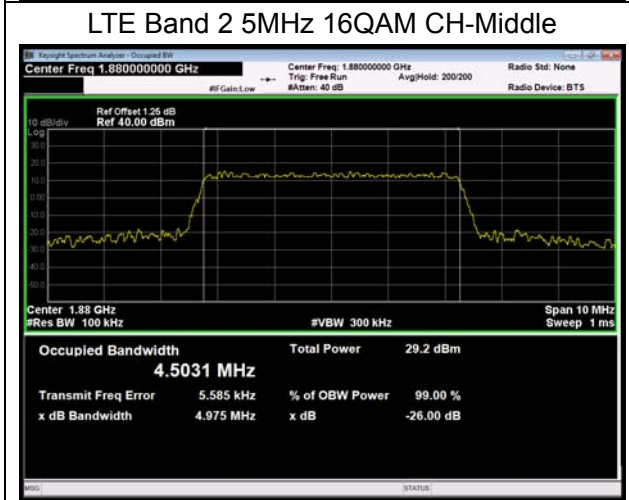
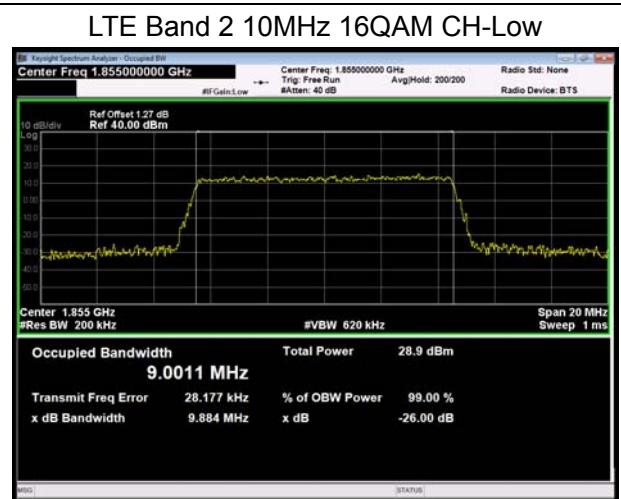
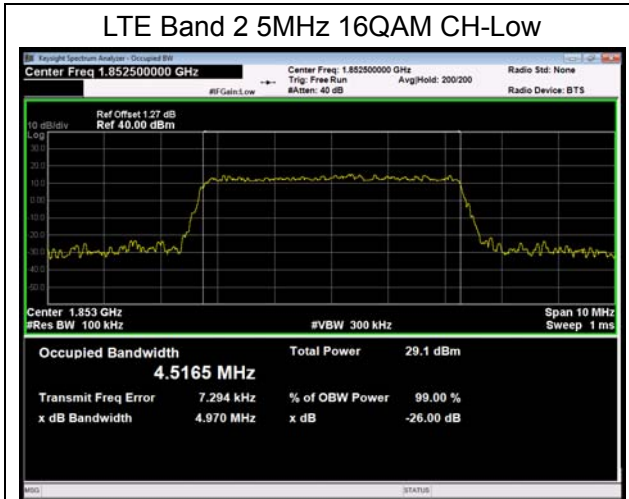

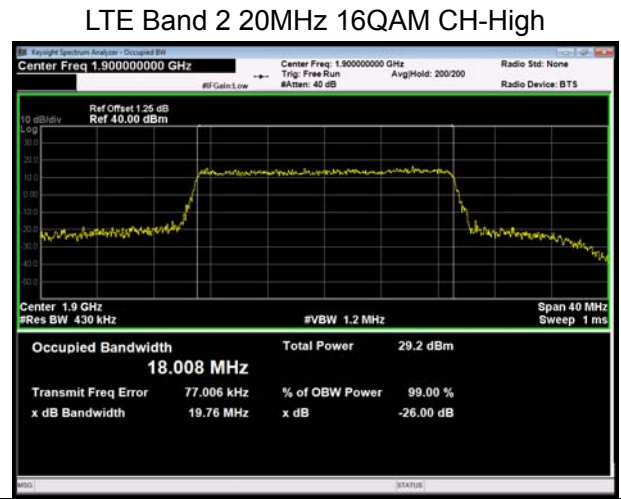
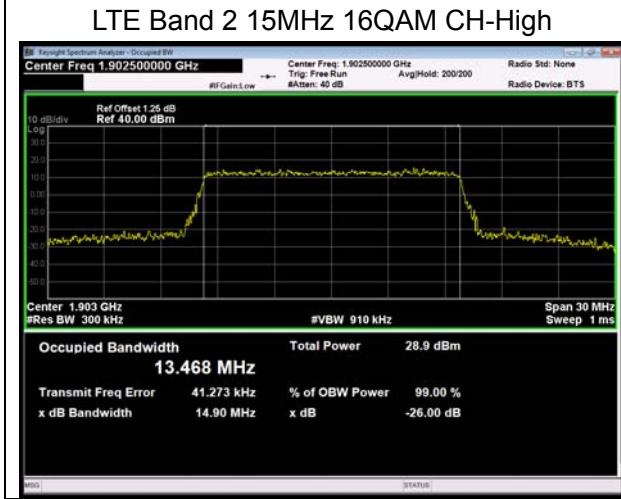
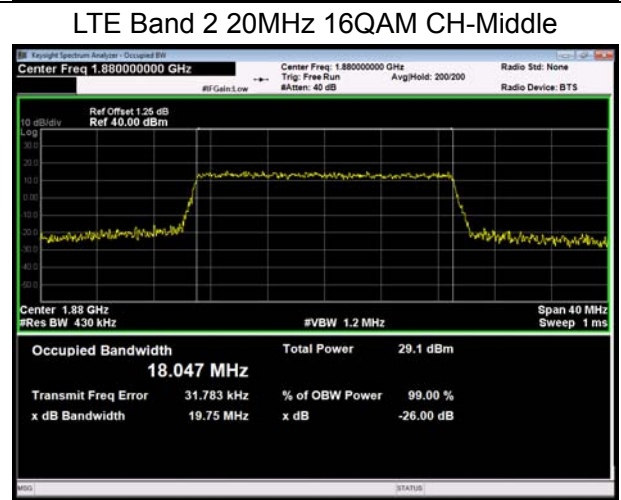
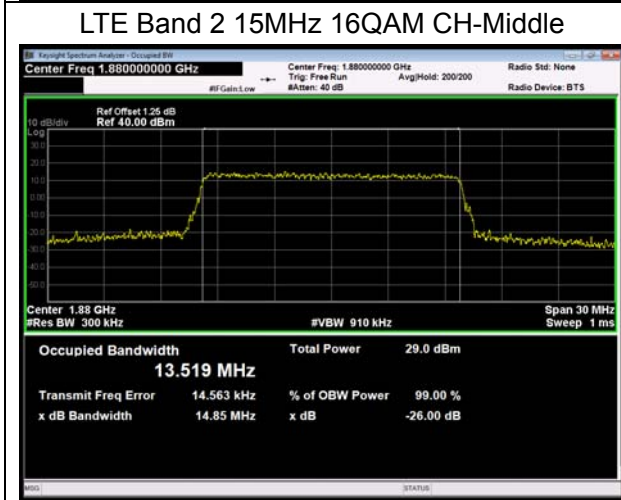
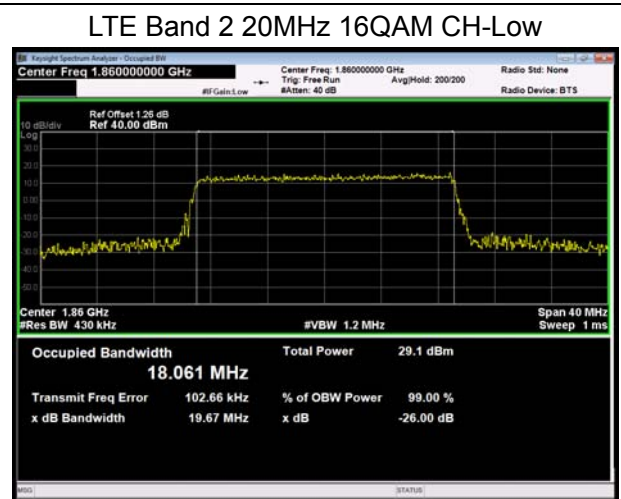
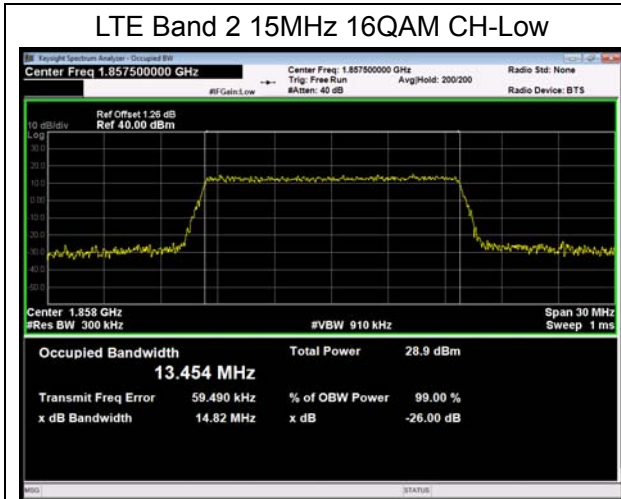

6.3. Band Edge Compliance

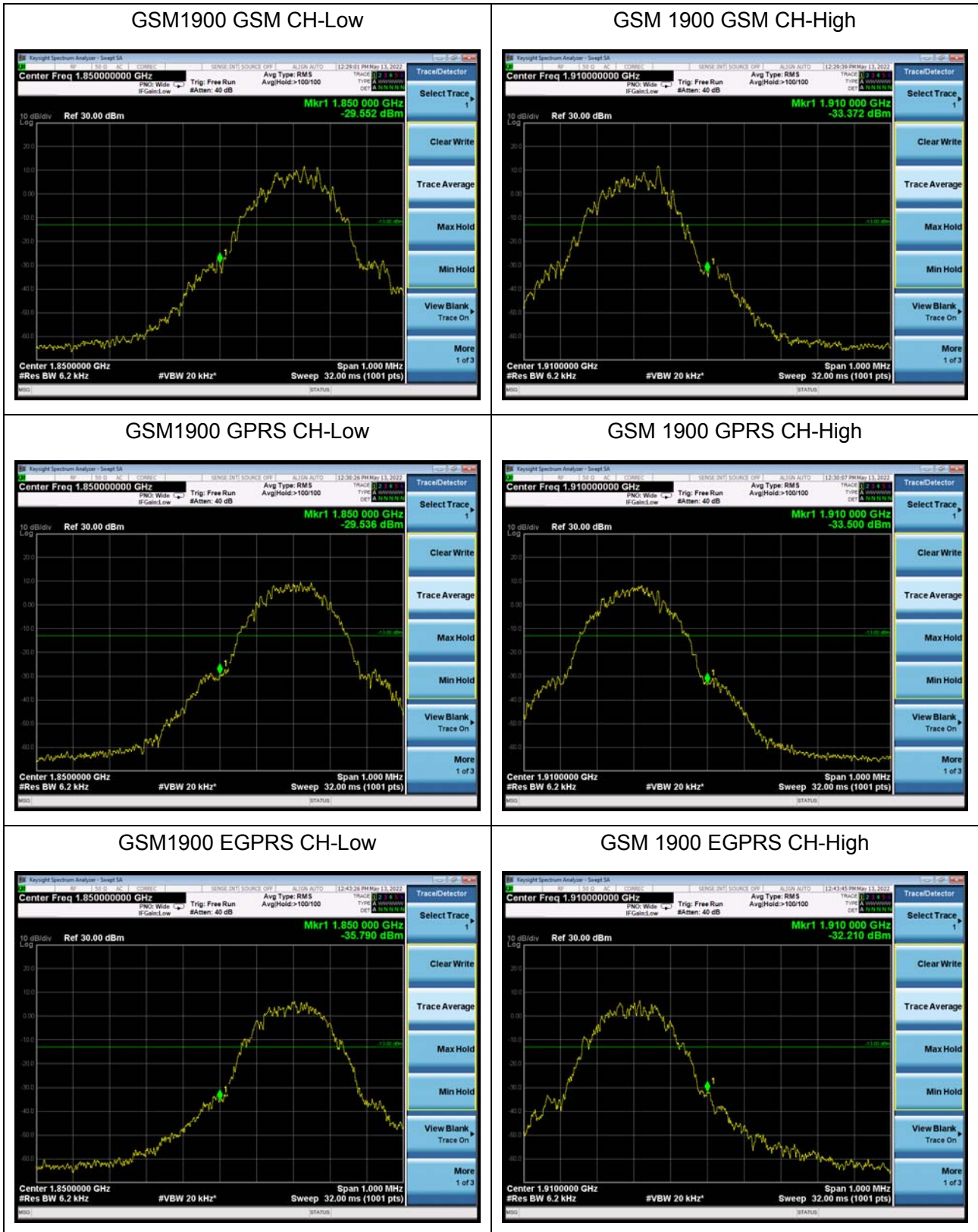



WCDMA Band II RMC CH-Low



WCDMA Band II RMC CH-High



LTE Band 2 1.4MHz QPSK 1RB CH-Low

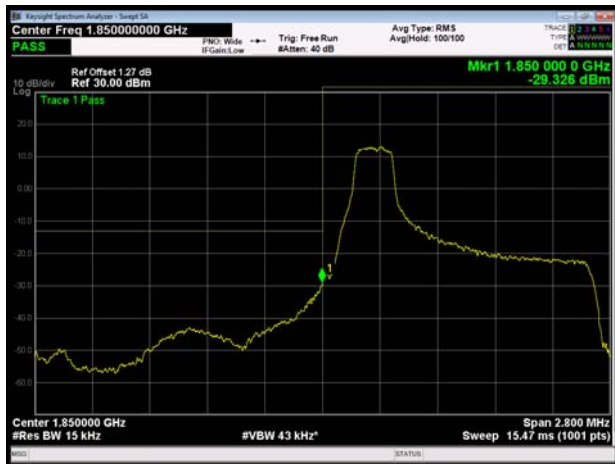

LTE Band 2 1.4MHz QPSK 1RB CH-High



LTE Band 2 1.4MHz QPSK 100%RB CH-Low



LTE Band 2 1.4MHz QPSK 100%RB CH-High





LTE Band 2 3MHz QPSK 1RB CH-Low

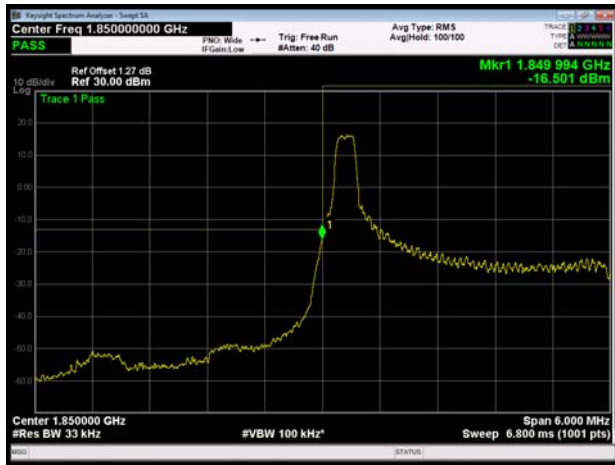

LTE Band 2 3MHz QPSK 1RB CH-High

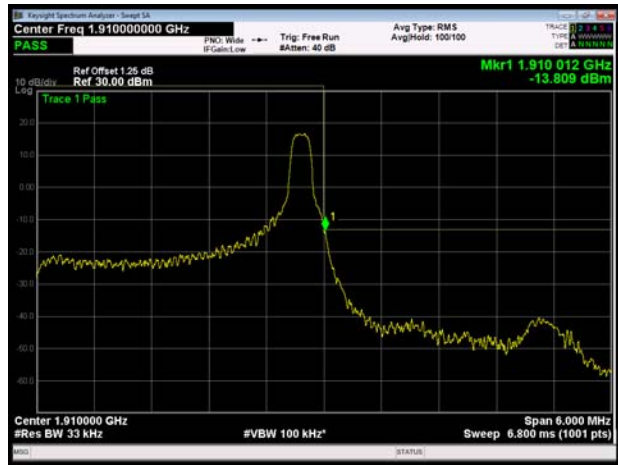

LTE Band 2 3MHz QPSK 100%RB CH-Low

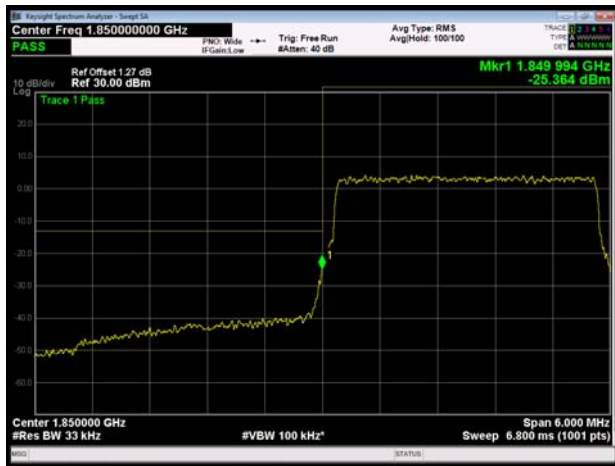

LTE Band 2 3MHz QPSK 100%RB CH-High

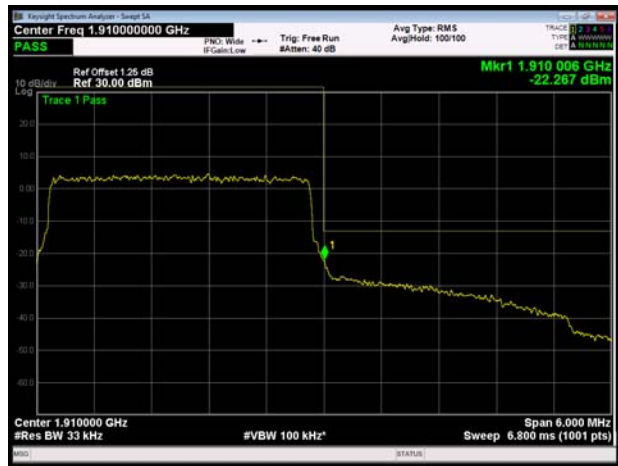

LTE Band 2 5MHz QPSK 1RB CH-Low

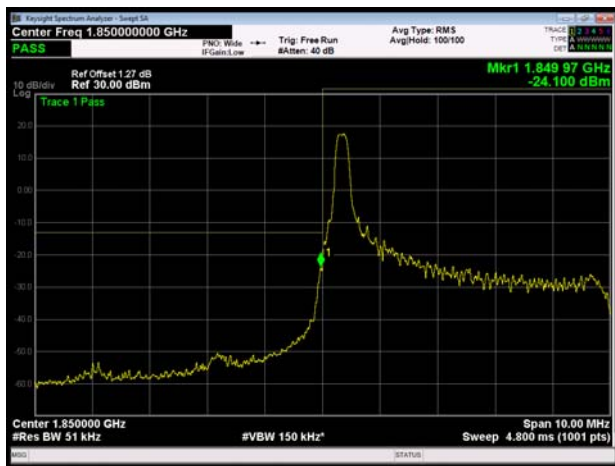

LTE Band 2 5MHz QPSK 1RB CH-High

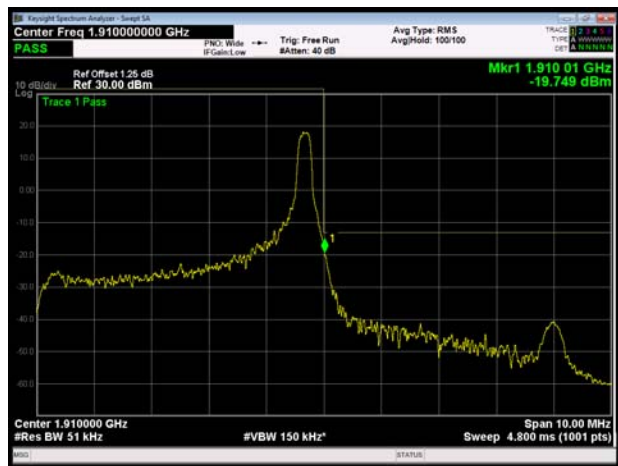



LTE Band 2 5MHz QPSK 100%RB CH-Low

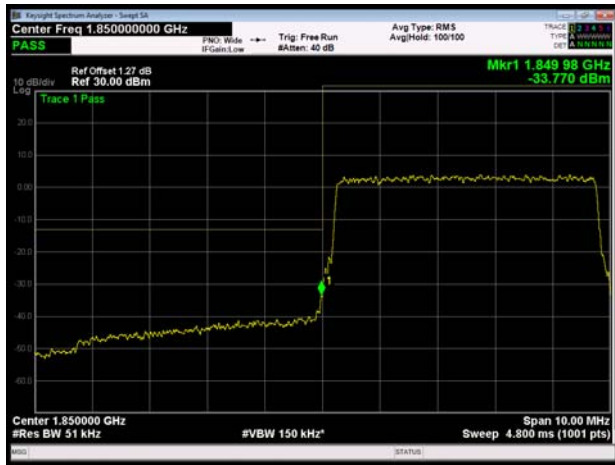

LTE Band 2 5MHz QPSK 100%RB CH-High

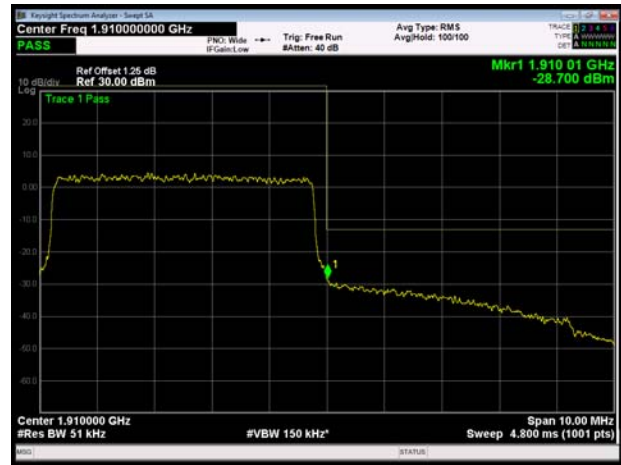

LTE Band 2 10MHz QPSK 1RB CH-Low

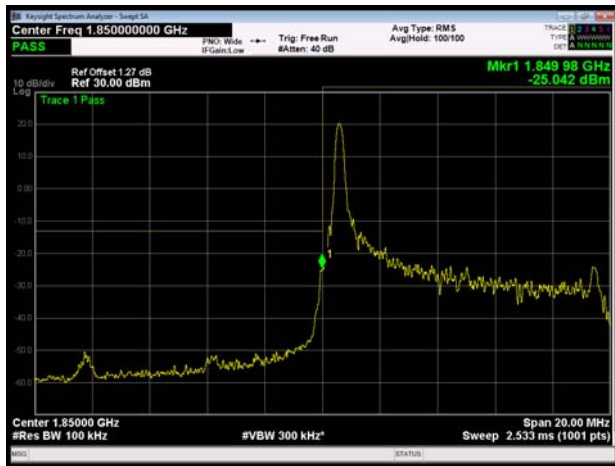

LTE Band 2 10MHz QPSK 1RB CH-High

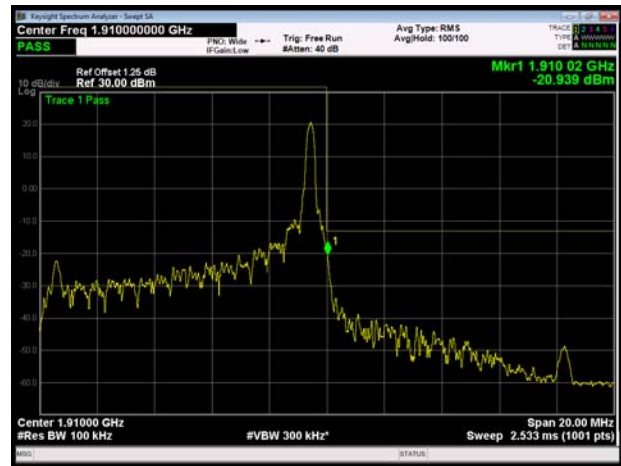

LTE Band 2 10MHz QPSK 100%RB CH-Low

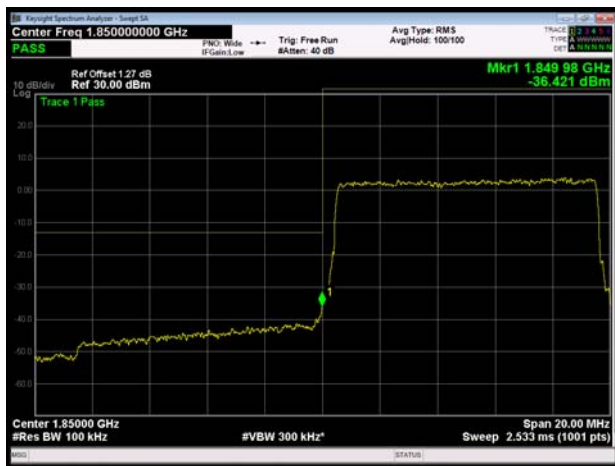

LTE Band 2 10MHz QPSK 100%RB CH-High





LTE Band 2 15MHz QPSK 1RB CH-Low

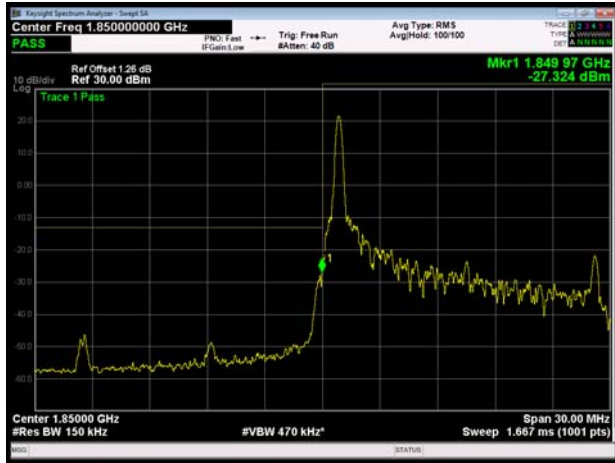

LTE Band 2 15MHz QPSK 1RB CH-High

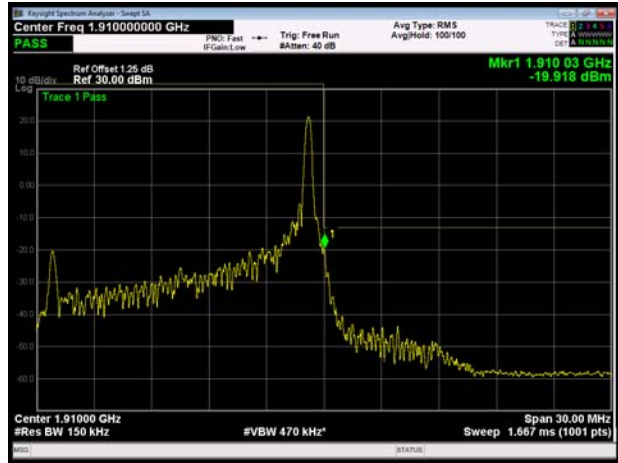

LTE Band 2 15MHz QPSK 100%RB CH-Low

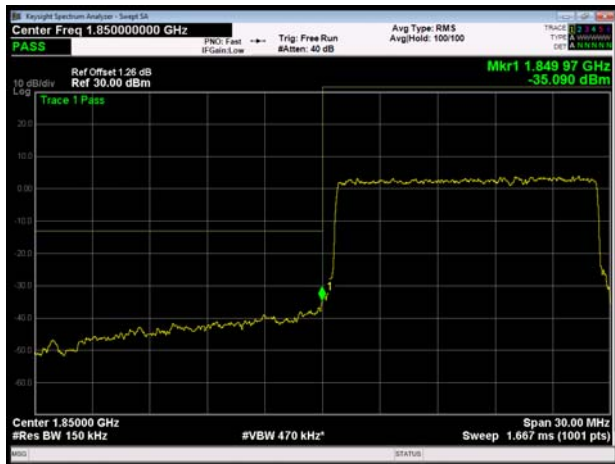

LTE Band 2 15MHz QPSK 100%RB CH-High





LTE Band 2 20MHz QPSK 1RB CH-Low

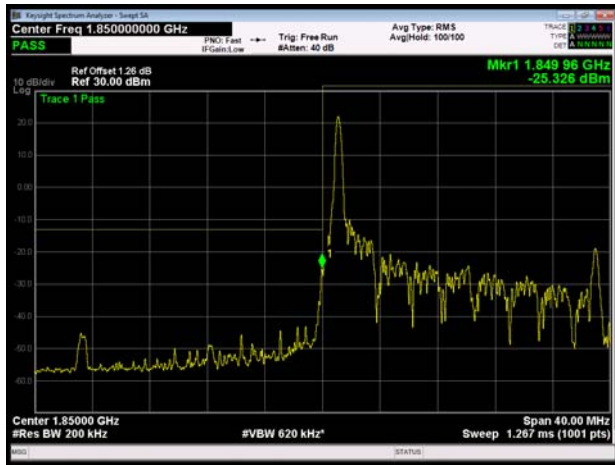

LTE Band 2 20MHz QPSK 1RB CH-High

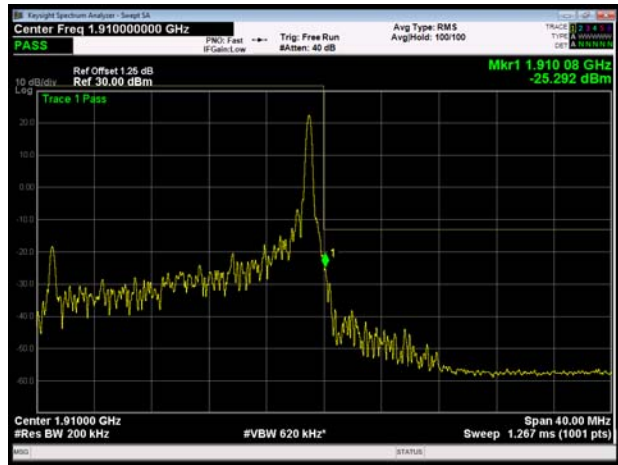

LTE Band 2 20MHz QPSK 100%RB CH-Low

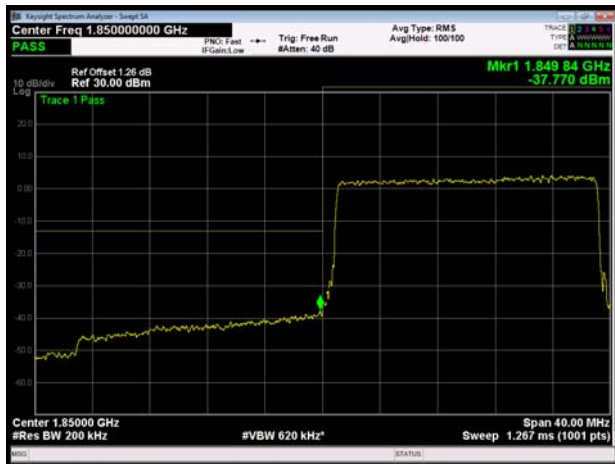

LTE Band 2 20MHz QPSK 100%RB CH-High



LTE Band 2 1.4MHz 16QAM 1RB CH-Low



LTE Band 2 1.4MHz 16QAM 1RB CH-High





LTE Band 2 1.4MHz 16QAM 100%RB CH-Low



LTE Band 2 1.4MHz 16QAM 100%RB CH-High



LTE Band 2 3MHz 16QAM 1RB CH-Low

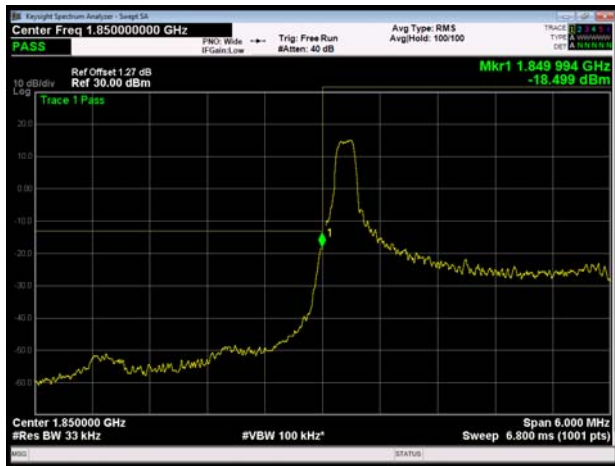

LTE Band 2 3MHz 16QAM 1RB CH-High

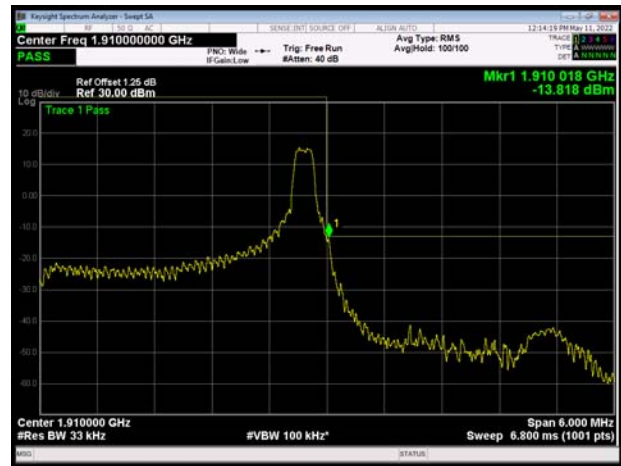

LTE Band 2 3MHz 16QAM 100%RB CH-Low

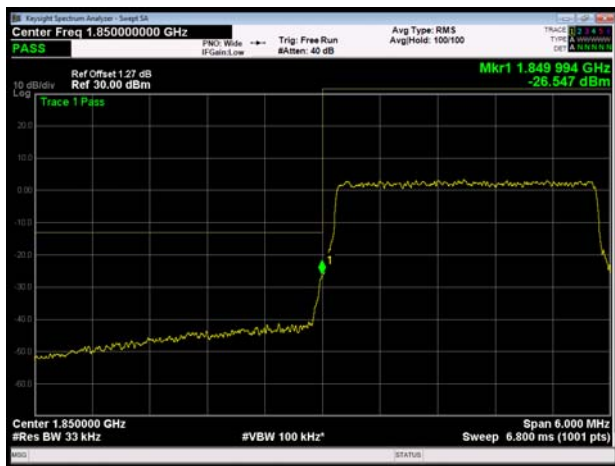

LTE Band 2 3MHz 16QAM 100%RB CH-High





LTE Band 2 5MHz 16QAM 1RB CH-Low

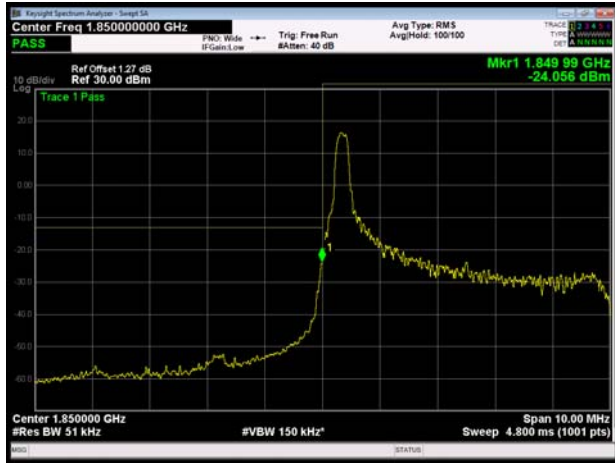

LTE Band 2 5MHz 16QAM 1RB CH-High

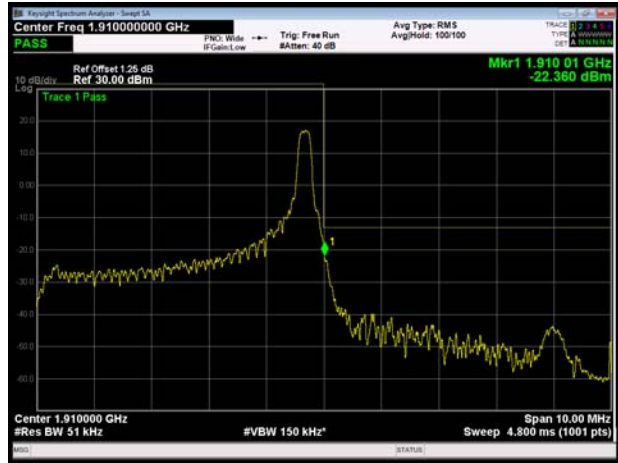

LTE Band 2 5MHz 16QAM 100%RB CH-Low

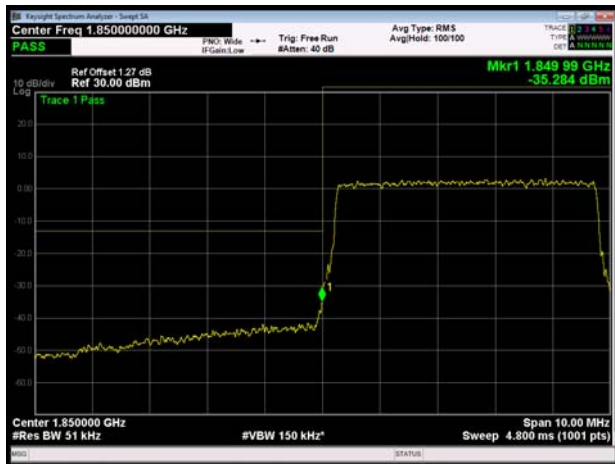

LTE Band 2 5MHz 16QAM 100%RB CH-High



LTE Band 2 10MHz 16QAM 1RB CH-Low

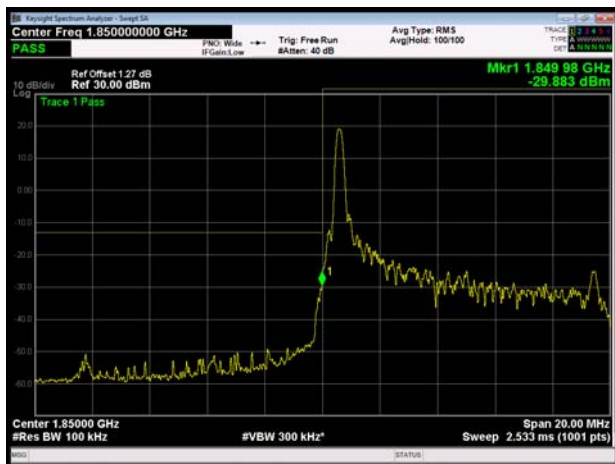

LTE Band 2 10MHz 16QAM 1RB CH-High

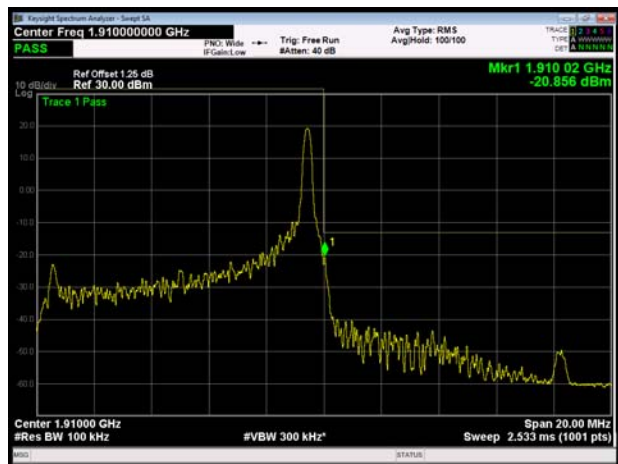



LTE Band 2 10MHz 16QAM 100%RB CH-Low



LTE Band 2 10MHz 16QAM 100%RB CH-High



LTE Band 2 15MHz 16QAM 1RB CH-Low

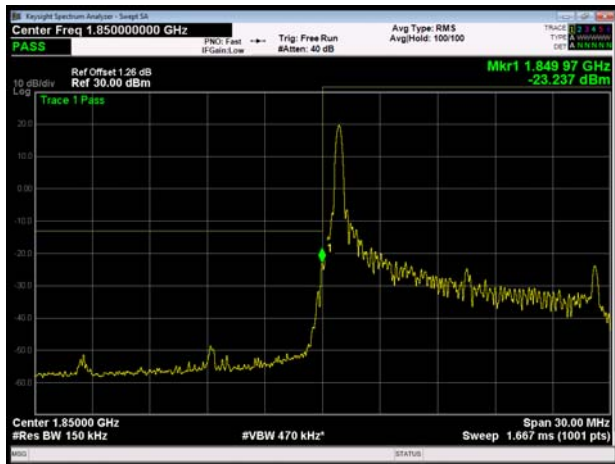

LTE Band 2 15MHz 16QAM 1RB CH-High

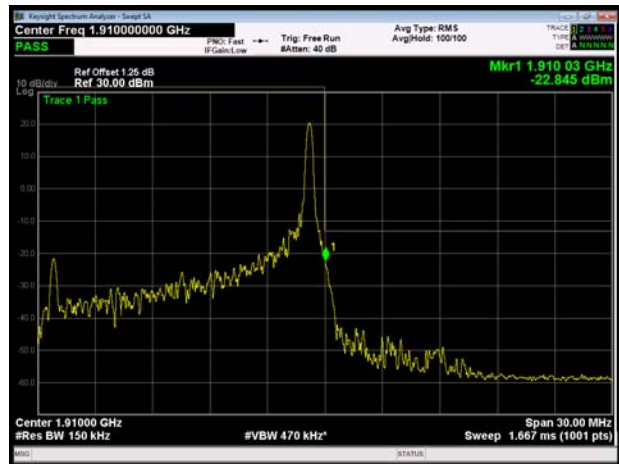

LTE Band 2 15MHz 16QAM 100%RB CH-Low

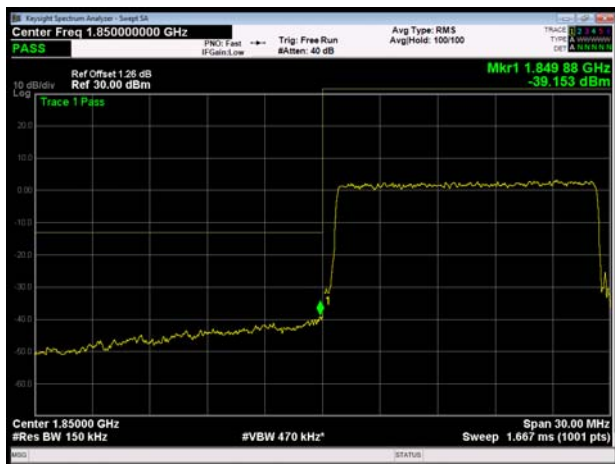

LTE Band 2 15MHz 16QAM 100%RB CH-High

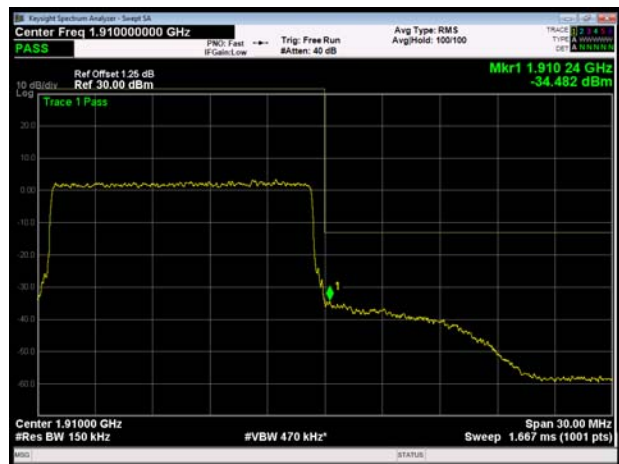



LTE Band 2 20MHz 16QAM 1RB CH-Low

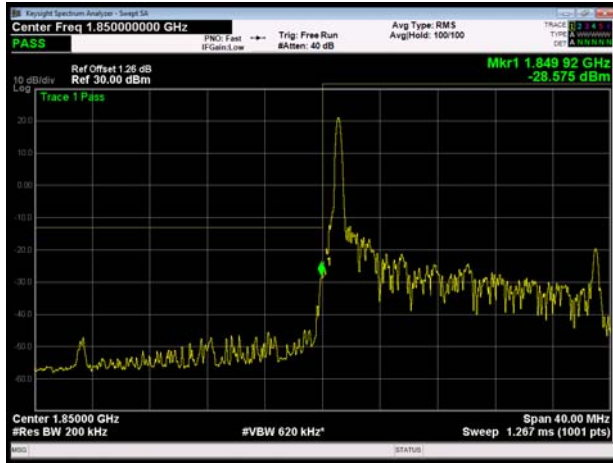

LTE Band 2 20MHz 16QAM 1RB CH-High

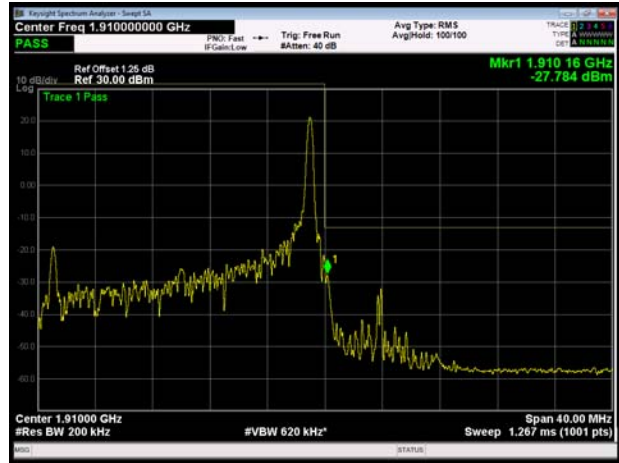

LTE Band 2 20MHz 16QAM 100%RB CH-Low

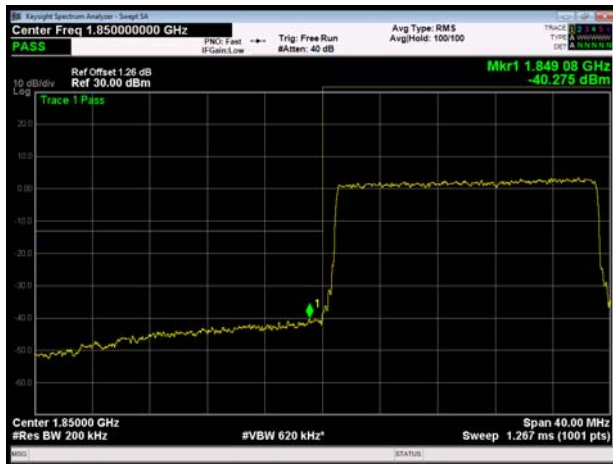

LTE Band 2 20MHz 16QAM 100%RB CH-High



6.4. Peak-to-Average Power Ratio (PAPR)

Mode	Channel	Frequency (MHz)	Peak(dBm)	Avg(dBm)	PAPR(dB)	Limit(dB)	Conclusion
GSM 1900 (GMSK)	512	1850.2	30.48	27.87	2.61	≤13	PASS
	661	1880	29.32	26.71	2.61	≤13	PASS
	810	1909.8	28.78	26.15	2.63	≤13	PASS
GPRS 1900 (GMSK)	512	1850.2	30.54	27.93	2.61	≤13	PASS
	661	1880	29.37	26.76	2.61	≤13	PASS
	810	1909.8	28.78	26.15	2.63	≤13	PASS
EGPRS 1900 (8PSK)	512	1850.2	29.84	24.58	5.26	≤13	PASS
	661	1880	29.42	24.30	5.12	≤13	PASS
	810	1909.8	28.39	23.18	5.21	≤13	PASS
WCDMA Band II (RMC)	9262	1852.4	26.31	23.32	2.99	≤13	PASS
	9400	1880	25.24	22.45	2.79	≤13	PASS
	9538	1907.6	24.41	21.89	2.52	≤13	PASS

LTE Band 2								
Modulation	Bandwidth (MHz)	Channel	Frequency (MHz)	Peak (dBm)	Avg (dBm)	PAPR (dB)	Limit (dB)	Conclusion
QPSK	1.4	18607	1850.7	27.00	21.80	5.20	≤13	PASS
		18900	1880.0	26.65	21.98	4.67	≤13	PASS
		19193	1909.3	25.67	22.00	3.67	≤13	PASS
	3	18615	1851.5	26.96	21.75	5.21	≤13	PASS
		18900	1880	26.62	21.90	4.72	≤13	PASS
		19185	1908.5	25.84	21.89	3.95	≤13	PASS
	5	18625	1852.5	27.00	21.72	5.28	≤13	PASS
		18900	1880	26.60	21.97	4.63	≤13	PASS
		19175	1907.5	26.11	21.93	4.18	≤13	PASS
	10	18650	1855	27.12	21.83	5.29	≤13	PASS
		18900	1880	26.72	21.99	4.73	≤13	PASS
		19150	1905	26.67	21.92	4.75	≤13	PASS
	15	18675	1857.5	27.52	21.88	5.64	≤13	PASS
		18900	1880	27.09	21.95	5.14	≤13	PASS
		19125	1902.5	27.15	21.94	5.21	≤13	PASS
	20	18700	1860	27.31	21.86	5.45	≤13	PASS
		18900	1880	27.06	21.89	5.17	≤13	PASS
		19100	1900	27.16	21.95	5.21	≤13	PASS
16QAM	1.4	18607	1850.7	26.94	21.03	5.91	≤13	PASS



		18900	1880.0	26.49	20.97	5.52	≤13	PASS
		19193	1909.3	25.66	21.12	4.54	≤13	PASS
	3	18615	1851.5	26.94	20.86	6.08	≤13	PASS
		18900	1880	26.56	20.99	5.57	≤13	PASS
		19185	1908.5	25.90	21.18	4.72	≤13	PASS
	5	18625	1852.5	26.89	20.90	5.99	≤13	PASS
		18900	1880	26.54	21.06	5.48	≤13	PASS
		19175	1907.5	26.08	20.94	5.14	≤13	PASS
	10	18650	1855	27.01	20.93	6.08	≤13	PASS
		18900	1880	26.55	20.94	5.61	≤13	PASS
		19150	1905	26.65	21.08	5.57	≤13	PASS
	15	18675	1857.5	27.17	21.03	6.14	≤13	PASS
		18900	1880	26.85	21.05	5.80	≤13	PASS
		19125	1902.5	26.89	21.06	5.83	≤13	PASS
	20	18700	1860	27.23	21.09	6.14	≤13	PASS
		18900	1880	26.89	20.97	5.92	≤13	PASS
		19100	1900	26.94	20.95	5.99	≤13	PASS

6.5. Frequency Stability

GSM1900						
Condition		Freq.Error (Hz)	Freq.Error (Hz)	Frequency Stability (ppm)	Frequency Stability (ppm)	Verdict
Temperature	Voltage	GMSK	8PSK	GMSK	8PSK	
Normal (25°C)	Normal	8.12	16.05	0.00432	0.00854	PASS
Extreme (50°C)		8.09	4.29	0.00430	0.00228	PASS
Extreme (40°C)		3.26	2.90	0.00173	0.00154	PASS
Extreme (30°C)		4.28	5.91	0.00228	0.00315	PASS
Extreme (20°C)		2.97	11.76	0.00158	0.00625	PASS
Extreme (10°C)		11.44	16.00	0.00609	0.00851	PASS
Extreme (0°C)		12.63	17.22	0.00672	0.00916	PASS
Extreme (-10°C)		8.26	5.59	0.00439	0.00298	PASS
Extreme (-20°C)		4.43	14.85	0.00236	0.00790	PASS
Extreme (-30°C)		7.71	16.71	0.00410	0.00889	PASS
25°C	LV	5.81	12.57	0.00309	0.00669	PASS
	HV	10.50	2.42	0.00559	0.00129	PASS

WCDMA Band II						
Condition		Freq.Error (Hz)	Freq.Error (Hz)	Frequency Stability (ppm)	Frequency Stability (ppm)	Verdict
Temperature	Voltage	QPSK	BPSK	QPSK	BPSK	
Normal (25°C)	Normal	2.79	17.64	0.00148	0.00938	PASS
Extreme (50°C)		12.02	17.33	0.00640	0.00922	PASS
Extreme (40°C)		11.92	13.77	0.00634	0.00733	PASS
Extreme (30°C)		7.83	13.67	0.00416	0.00727	PASS
Extreme (20°C)		17.57	10.06	0.00935	0.00535	PASS
Extreme (10°C)		6.03	17.38	0.00321	0.00925	PASS
Extreme (0°C)		7.89	2.41	0.00420	0.00128	PASS
Extreme (-10°C)		16.91	3.66	0.00899	0.00195	PASS
Extreme (-20°C)		12.05	4.61	0.00641	0.00245	PASS
Extreme (-30°C)		4.50	1.08	0.00239	0.00057	PASS
25°C	LV	8.95	16.38	0.00476	0.00871	PASS
	HV	14.85	1.24	0.00790	0.00066	PASS



LTE Band 2						
Condition		Freq.Error (Hz)	Freq.Error (Hz)	Frequency Stability (ppm)	Frequency Stability (ppm)	Verdict
BANDWIDTH	1.4MHz	16QAM	QPSK	16QAM	QPSK	
Temperature	Voltage					
Normal (25°C)	Normal	14.34	12.35	0.00763	0.00657	PASS
Extreme (50°C)		14.17	8.54	0.00754	0.00454	PASS
Extreme (40°C)		12.50	17.83	0.00665	0.00948	PASS
Extreme (30°C)		14.90	13.35	0.00792	0.00710	PASS
Extreme (20°C)		13.83	9.62	0.00736	0.00512	PASS
Extreme (10°C)		10.67	6.41	0.00568	0.00341	PASS
Extreme (0°C)		12.94	4.67	0.00688	0.00248	PASS
Extreme (-10°C)		8.46	7.26	0.00450	0.00386	PASS
Extreme (-20°C)		7.60	8.97	0.00405	0.00477	PASS
Extreme (-30°C)		6.89	10.82	0.00367	0.00576	PASS
25°C	LV	16.50	8.13	0.00878	0.00433	PASS
	HV	13.23	9.32	0.00704	0.00496	PASS
Condition		Freq.Error (Hz)	Freq.Error (Hz)	Frequency Stability (ppm)	Frequency Stability (ppm)	Verdict
BANDWIDTH	3MHz	16QAM	QPSK	16QAM	QPSK	
Temperature	Voltage					
Normal (25°C)	Normal	13.51	17.05	0.00719	0.00907	PASS
Extreme (50°C)		9.02	3.06	0.00480	0.00163	PASS
Extreme (40°C)		11.79	5.91	0.00627	0.00314	PASS
Extreme (30°C)		6.67	9.65	0.00355	0.00513	PASS
Extreme (20°C)		14.53	5.07	0.00773	0.00269	PASS
Extreme (10°C)		13.30	12.93	0.00707	0.00688	PASS
Extreme (0°C)		6.04	9.60	0.00322	0.00510	PASS
Extreme (-10°C)		2.92	4.15	0.00155	0.00221	PASS
Extreme (-20°C)		2.14	9.07	0.00114	0.00482	PASS
Extreme (-30°C)		7.34	5.60	0.00390	0.00298	PASS
25°C	LV	4.54	12.11	0.00242	0.00644	PASS
	HV	2.71	4.19	0.00144	0.00223	PASS
Condition		Freq.Error (Hz)	Freq.Error (Hz)	Frequency Stability (ppm)	Frequency Stability (ppm)	Verdict
BANDWIDTH	5MHz	16QAM	QPSK	16QAM	QPSK	
Temperature	Voltage					
Normal (25°C)	Normal	5.06	14.75	0.00269	0.00785	PASS
Extreme (50°C)		10.53	16.86	0.00560	0.00897	PASS
Extreme (40°C)		4.37	14.46	0.00232	0.00769	PASS



Extreme (30°C)		9.88	15.08	0.00525	0.00802	PASS
Extreme (20°C)		12.71	16.49	0.00676	0.00877	PASS
Extreme (10°C)		2.07	2.53	0.00110	0.00134	PASS
Extreme (0°C)		15.05	12.61	0.00801	0.00671	PASS
Extreme (-10°C)		17.44	1.45	0.00928	0.00077	PASS
Extreme (-20°C)		1.49	4.54	0.00079	0.00242	PASS
Extreme (-30°C)		14.28	3.61	0.00759	0.00192	PASS
25°C	LV	6.12	15.75	0.00326	0.00838	PASS
	HV	9.02	7.45	0.00480	0.00396	PASS
Condition		Freq.Error (Hz)	Freq.Error (Hz)	Frequency Stability (ppm)	Frequency Stability (ppm)	Verdict
BANDWIDTH	10MHz					
Temperature	Voltage	16QAM	QPSK	16QAM	QPSK	
Normal (25°C)	Normal	3.69	10.36	0.00196	0.00551	
Extreme (50°C)		3.89	16.57	0.00207	0.00881	PASS
Extreme (40°C)		17.44	2.97	0.00928	0.00158	PASS
Extreme (30°C)		3.01	16.79	0.00160	0.00893	PASS
Extreme (20°C)		15.58	16.45	0.00829	0.00875	PASS
Extreme (10°C)		3.31	5.83	0.00176	0.00310	PASS
Extreme (0°C)		10.07	17.23	0.00536	0.00916	PASS
Extreme (-10°C)		10.25	16.32	0.00545	0.00868	PASS
Extreme (-20°C)		1.22	16.30	0.00065	0.00867	PASS
Extreme (-30°C)		5.56	2.76	0.00296	0.00147	PASS
25°C	LV	15.75	6.02	0.00838	0.00320	PASS
	HV	15.10	9.27	0.00803	0.00493	PASS
Condition		Freq.Error (Hz)	Freq.Error (Hz)	Frequency Stability (ppm)	Frequency Stability (ppm)	Verdict
BANDWIDTH	15MHz					
Temperature	Voltage	16QAM	QPSK	16QAM	QPSK	
Normal (25°C)	Normal	7.75	5.77	0.00412	0.00307	
Extreme (50°C)		2.97	6.49	0.00158	0.00345	PASS
Extreme (40°C)		11.60	4.55	0.00617	0.00242	PASS
Extreme (30°C)		17.36	3.37	0.00924	0.00179	PASS
Extreme (20°C)		14.20	14.35	0.00755	0.00763	PASS
Extreme (10°C)		9.48	6.06	0.00504	0.00322	PASS
Extreme (0°C)		1.24	16.37	0.00066	0.00871	PASS
Extreme (-10°C)		17.54	13.21	0.00933	0.00703	PASS
Extreme (-20°C)		13.01	15.28	0.00692	0.00813	PASS
Extreme (-30°C)		15.99	10.79	0.00851	0.00574	PASS
25°C	LV	1.94	13.00	0.00103	0.00692	PASS
	HV	1.18	15.66	0.00063	0.00833	PASS



Condition		Freq.Error (Hz)	Freq.Error (Hz)	Frequency Stability (ppm)	Frequency Stability (ppm)	Verdict
BANDWIDTH	20MHz					
Temperature	Voltage	16QAM	QPSK	16QAM	QPSK	
Normal (25°C)	Normal	15.92	6.97	0.00847	0.00371	PASS
Extreme (50°C)		16.98	17.03	0.00903	0.00906	PASS
Extreme (40°C)		8.51	7.89	0.00453	0.00420	PASS
Extreme (30°C)		12.84	16.34	0.00683	0.00869	PASS
Extreme (20°C)		11.19	4.99	0.00595	0.00265	PASS
Extreme (10°C)		8.15	3.63	0.00434	0.00193	PASS
Extreme (0°C)		4.89	12.10	0.00260	0.00644	PASS
Extreme (-10°C)		16.92	12.17	0.00900	0.00647	PASS
Extreme (-20°C)		5.54	13.64	0.00295	0.00726	PASS
Extreme (-30°C)		15.83	9.88	0.00842	0.00526	PASS
25°C	LV	2.12	3.82	0.00113	0.00203	PASS
	HV	14.93	15.61	0.00794	0.00830	PASS

6.6. Spurious Emissions at Antenna Terminals

Sweep the whole frequency band through the range from 9kHz to the 10th harmonic of the carrier, the emissions more than 20 dB below the limit are not reported. The signal beyond the limit is carrier.

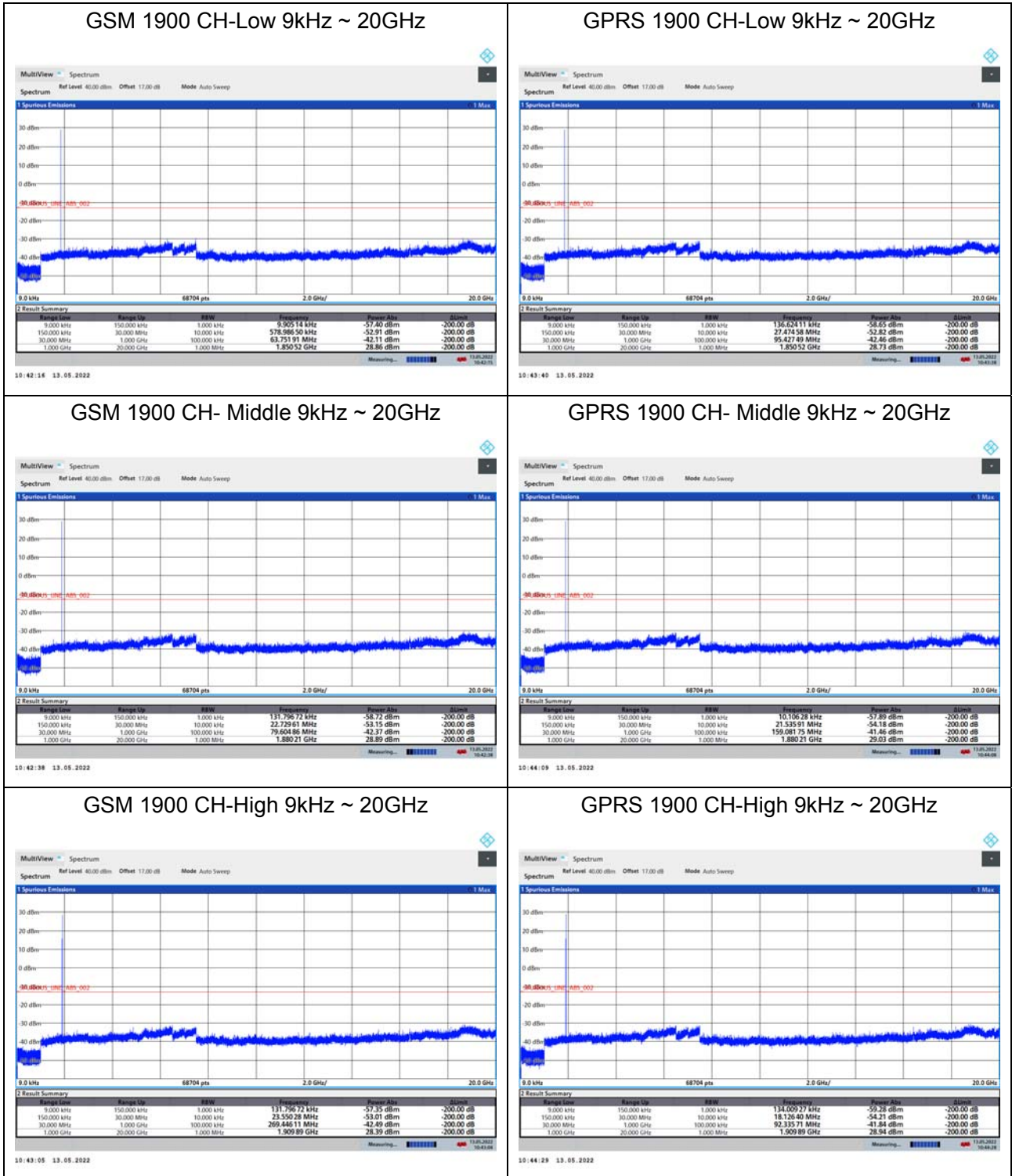



EGPRS 1900 CH-Low 9kHz ~ 20GHz

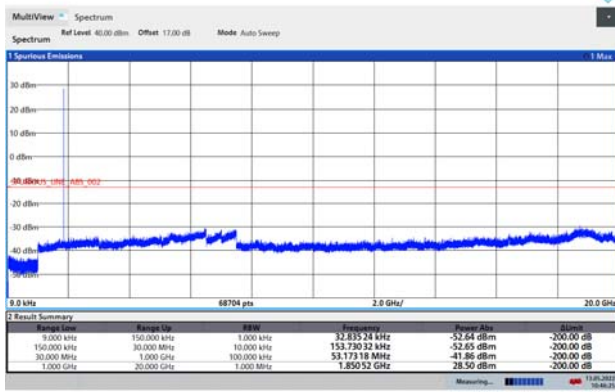

10:44:28 13.05.2022

WCDMA BAND II CH-Low 9kHz ~ 20GHz

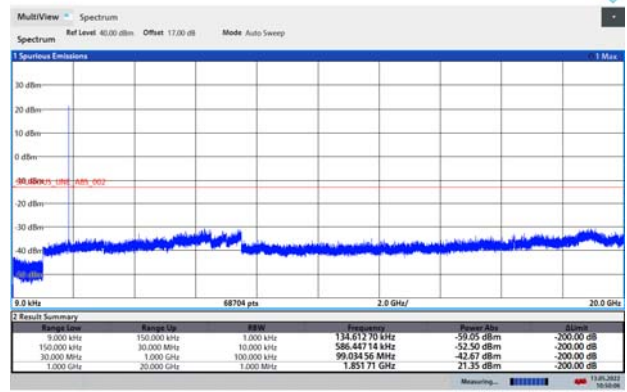

10:50:07 13.05.2022

EGPRS 1900 CH- Middle 9kHz ~ 20GHz

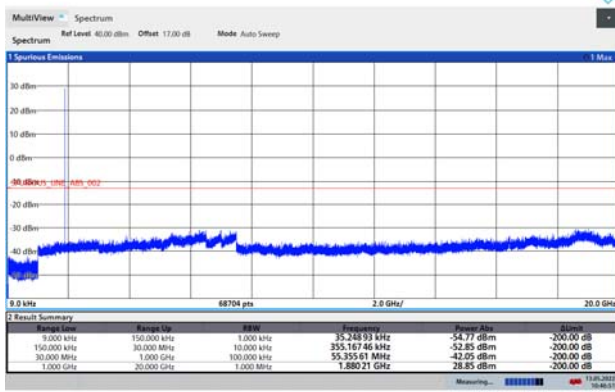

10:44:51 13.05.2022

WCDMA BAND II CH- Middle 9kHz ~ 20GHz

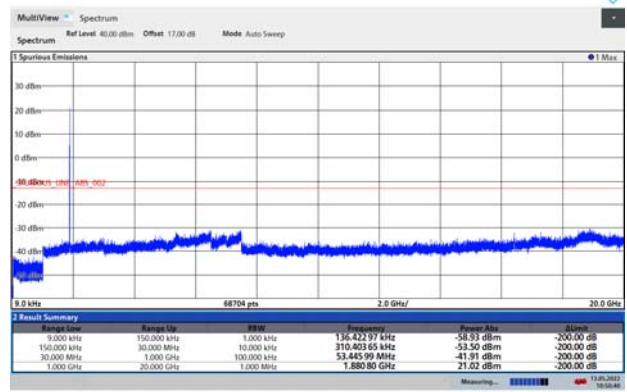

10:50:41 13.05.2022

EGPRS 1900 CH-High 9kHz ~ 20GHz

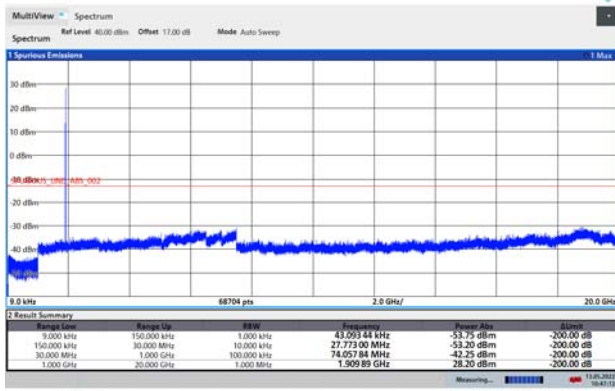

10:47:13 13.05.2022

WCDMA BAND II CH-High 9kHz ~ 20GHz

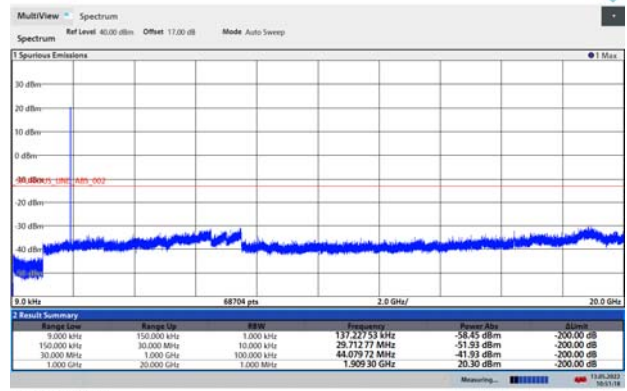

10:51:18 13.05.2022

LTE Band 2 1.4MHz CH-Low 9kHz~20GHz

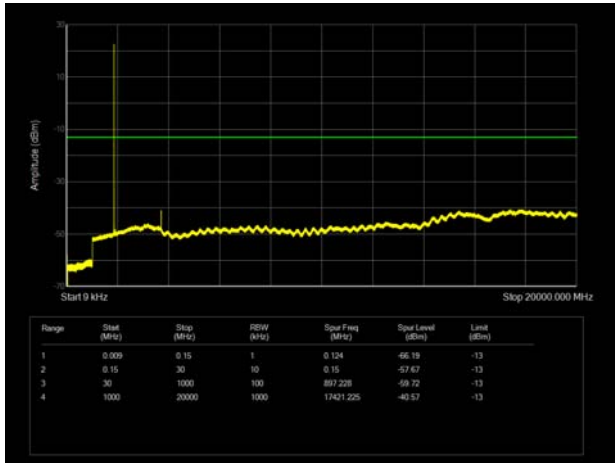

LTE Band 2 3MHz CH-Low 9kHz~20GHz

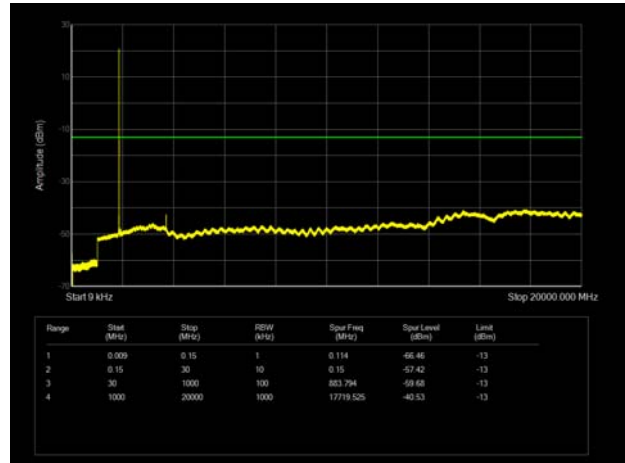

LTE Band 2 1.4MHz CH-Middle 9kHz~20GHz

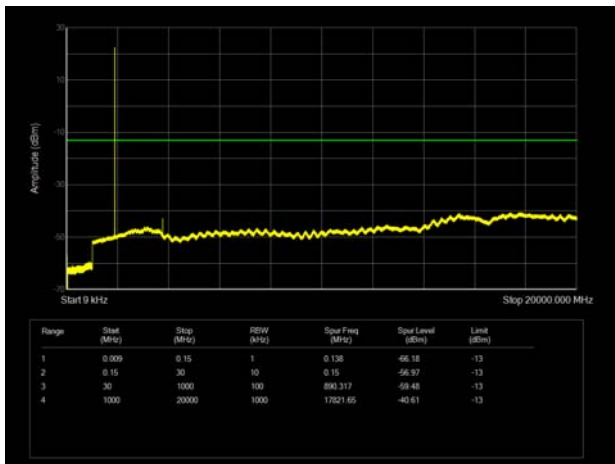

LTE Band 2 3MHz CH-Middle 9kHz~20GHz

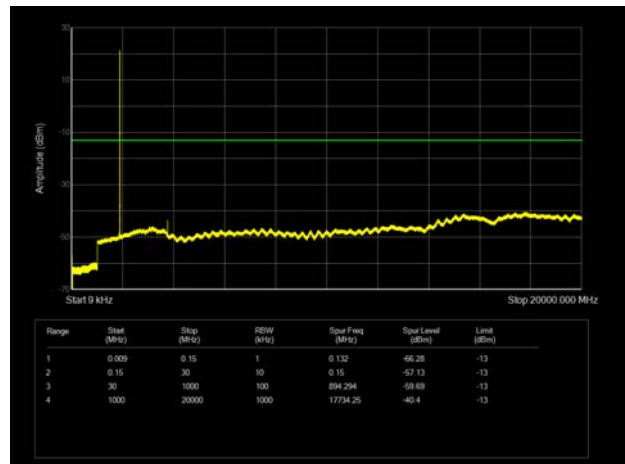

LTE Band 2 1.4MHz CH-High 9kHz~20GHz

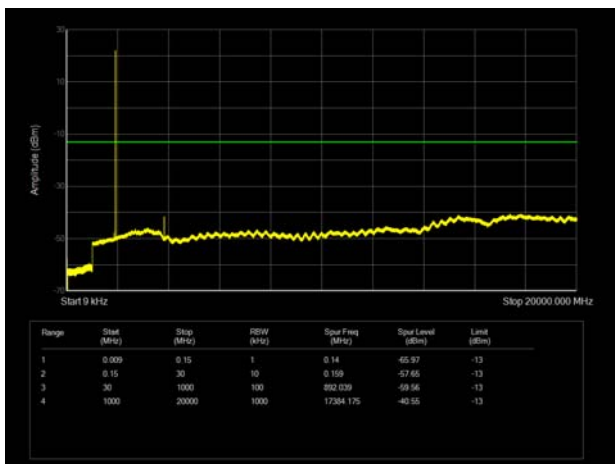

LTE Band 2 3MHz CH-High 9kHz~20GHz

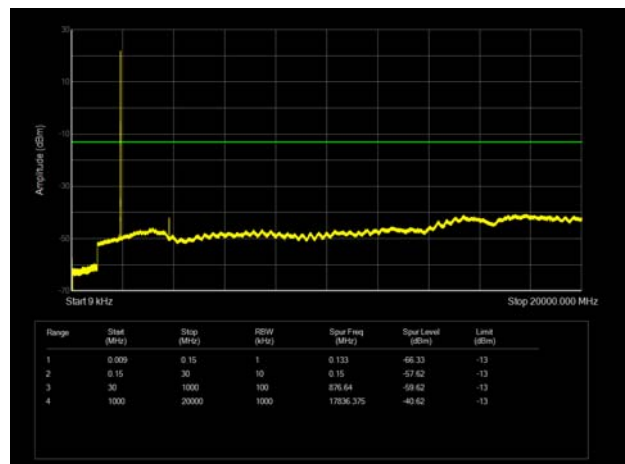

LTE Band 2 5MHz CH-Low 9kHz~20GHz

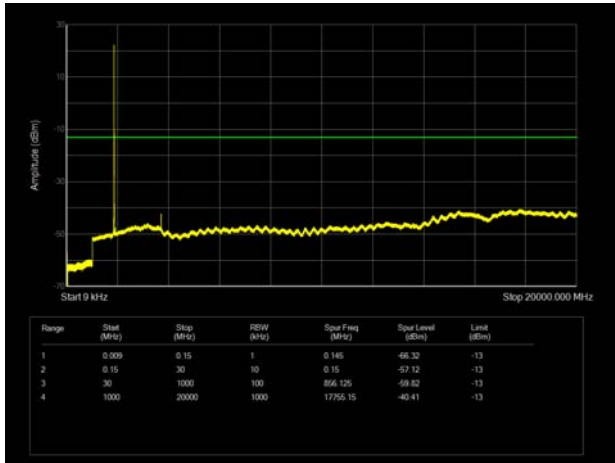

LTE Band 2 10MHz CH-Low 9kHz~20GHz

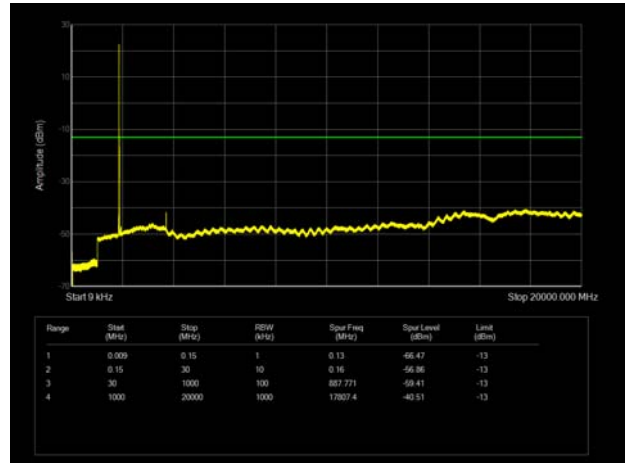

LTE Band 2 5MHz CH-Middle 9kHz~20GHz

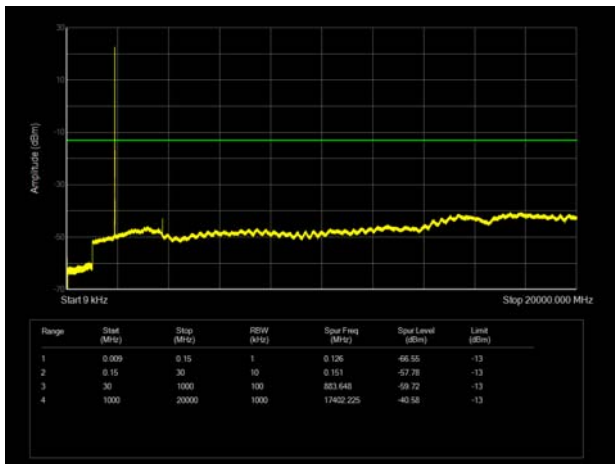

LTE Band 2 10MHz CH-Middle 9kHz~20GHz

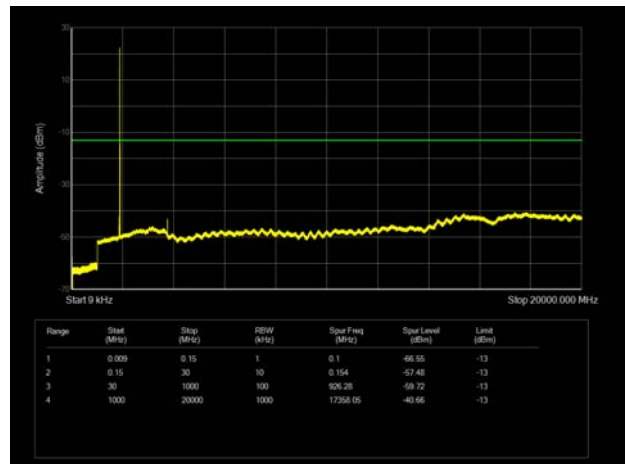

LTE Band 2 5MHz CH-High 9kHz~20GHz

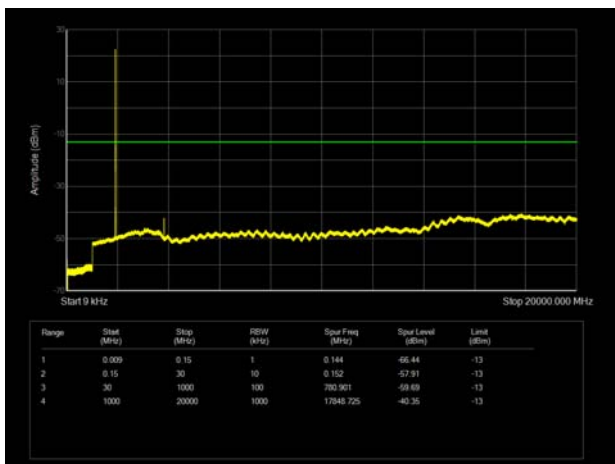

LTE Band 2 10MHz CH-High 9kHz~20GHz

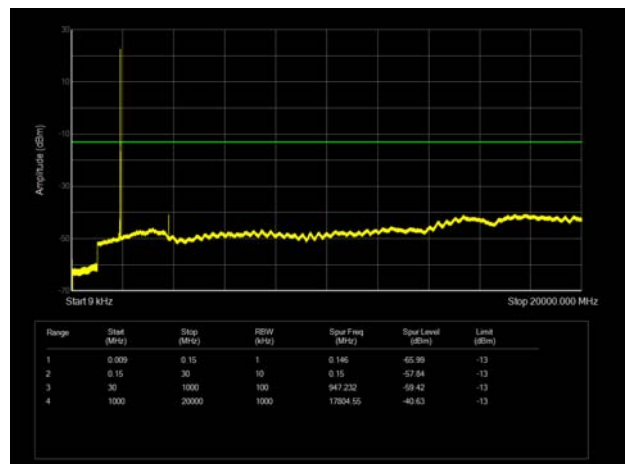

LTE Band 2 15MHz CH-Low 9kHz~20GHz

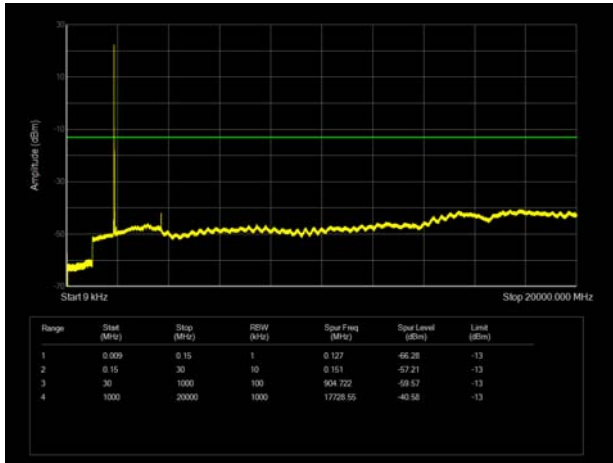

LTE Band 2 20MHz CH-Low 9kHz~20GHz

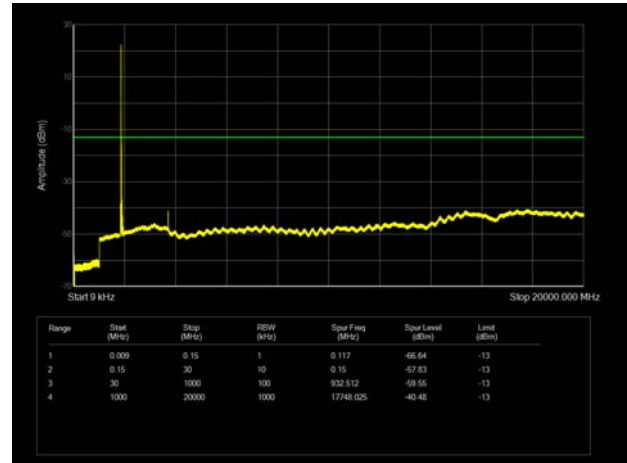

LTE Band 2 15MHz CH-Middle 9kHz~20GHz

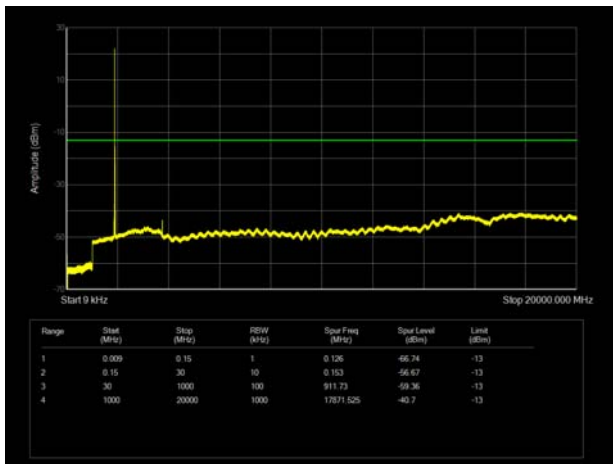

LTE Band 2 20MHz CH-Middle 9kHz~20GHz

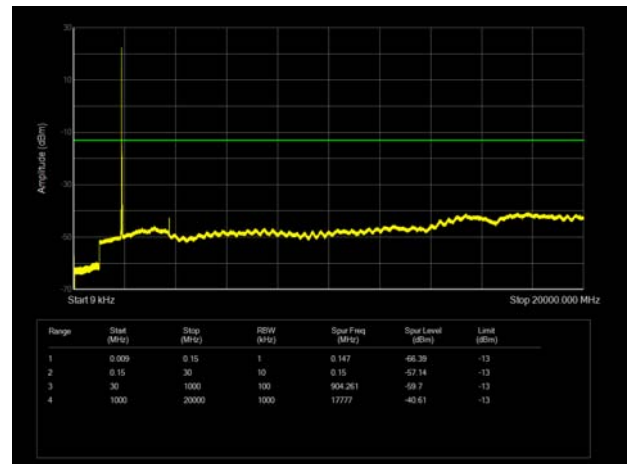

LTE Band 2 15MHz CH-High 9kHz~20GHz

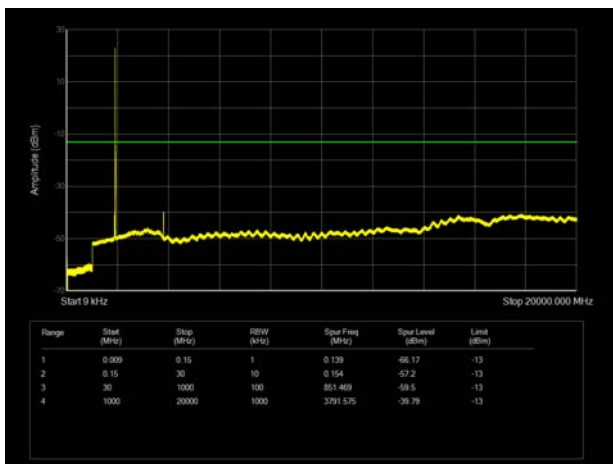

LTE Band 2 20MHz CH-High 9kHz~20GHz

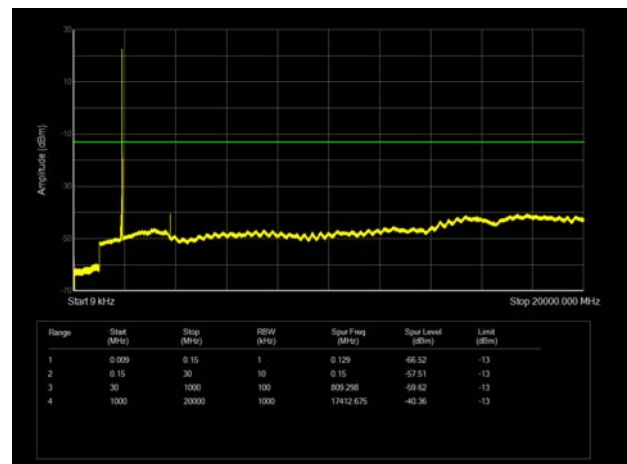

6.7. Radiates Spurious Emission

Sweep the whole frequency band through the range from 9kHz to the 10th harmonic of the carrier, the emissions below the noise floor will not be recorded in the report.

GSM 1900 CH-Middle

Harmonic	Frequency (MHz)	SG (dBm)	Cable Loss (dB)	Gain (dBi)	Antenna Polarization	EIRP Level (dBm)	Limit (dBm)	Margin (dB)	Azimuth (deg)
2	3760.00	-61.91	2.60	12.50	Horizontal	-52.01	-13.00	39.01	0
3	5640.00	-62.93	3.30	12.50	Horizontal	-53.73	-13.00	40.73	45
4	7520.00	-56.17	4.20	12.20	Horizontal	-48.17	-13.00	35.17	90
5	9400.00	-53.97	4.30	11.10	Horizontal	-47.17	-13.00	34.17	45
6	11280.00	-50.73	5.90	11.90	Horizontal	-44.73	-13.00	31.73	0
7	13160.00	-51.78	5.70	14.00	Horizontal	-43.48	-13.00	30.48	225
8	15040.00	-51.74	5.80	13.10	Horizontal	-44.44	-13.00	31.44	45
9	16920.00	-50.94	6.10	14.60	Horizontal	-42.44	-13.00	29.44	0
10	18800.00	-	-	-	-	-	-	-	-

Note: 1. The other Spurious RF Radiated emissions level is no more than noise floor.
 2. The worst emission was found in the antenna is Horizontal position.

WCDMA Band II CH-Middle

Harmonic	Frequency (MHz)	SG (dBm)	Cable Loss (dB)	Gain (dBi)	Antenna Polarization	EIRP Level (dBm)	Limit (dBm)	Margin (dB)	Azimuth (deg)
2	3760.00	-63.82	2.60	12.50	Horizontal	-53.92	-13.00	40.92	45
3	5640.00	-65.84	3.30	12.50	Horizontal	-56.64	-13.00	43.64	270
4	7520.00	-51.39	4.20	12.20	Horizontal	-43.39	-13.00	30.39	90
5	9400.00	-53.39	4.30	11.10	Horizontal	-46.59	-13.00	33.59	315
6	11280.00	-50.49	5.90	11.90	Horizontal	-44.49	-13.00	31.49	0
7	13160.00	-52.20	5.70	14.00	Horizontal	-43.90	-13.00	30.90	45
8	15040.00	-51.69	5.80	13.10	Horizontal	-44.39	-13.00	31.39	180
9	16920.00	-50.30	6.10	14.60	Horizontal	-41.80	-13.00	28.80	90
10	18800.00	-	-	-	-	-	-	-	-

Note: 1. The other Spurious RF Radiated emissions level is no more than noise floor.
 2. The worst emission was found in the antenna is Horizontal position.



LTE Band 2 1.4MHz CH-Middle

Harmonic	Frequency (MHz)	SG (dBm)	Cable Loss (dB)	Gain (dBi)	Antenna Polarization	EIRP Level (dBm)	Limit (dBm)	Margin (dB)	Azimuth (deg)
2	3759.00	-64.00	2.60	12.50	Vertical	-54.10	-13.00	41.10	0
3	5638.88	-62.21	3.30	12.50	Vertical	-53.01	-13.00	40.01	45
4	7520.00	-51.08	4.20	12.20	Vertical	-43.08	-13.00	30.08	0
5	9400.00	-54.50	4.30	11.10	Vertical	-47.70	-13.00	34.70	135
6	11280.00	-50.96	5.90	11.90	Vertical	-44.96	-13.00	31.96	0
7	13160.00	-53.61	5.70	14.00	Vertical	-45.31	-13.00	32.31	45
8	15040.00	-53.80	5.80	13.10	Vertical	-46.50	-13.00	33.50	225
9	16920.00	-51.63	6.10	14.60	Vertical	-43.13	-13.00	30.13	45
10	18800.00	-	-	-	-	-	-	-	-

Note: 1. The other Spurious RF Radiated emissions level is no more than noise floor.
2. The worst emission was found in the antenna is Vertical position.

LTE Band 2 5MHz CH-Middle

Harmonic	Frequency (MHz)	SG (dBm)	Cable Loss (dB)	Gain (dBi)	Antenna Polarization	EIRP Level (dBm)	Limit (dBm)	Margin (dB)	Azimuth (deg)
2	3755.63	-62.75	2.60	12.50	Vertical	-52.85	-13.00	39.85	45
3	5633.63	-61.30	3.30	12.50	Vertical	-52.10	-13.00	39.10	0
4	7520.00	-54.61	4.20	12.20	Vertical	-46.61	-13.00	33.61	225
5	9400.00	-53.13	4.30	11.10	Vertical	-46.33	-13.00	33.33	45
6	11280.00	-45.92	5.90	11.90	Vertical	-39.92	-13.00	26.92	90
7	13160.00	-53.39	5.70	14.00	Vertical	-45.09	-13.00	32.09	45
8	15040.00	-52.34	5.80	13.10	Vertical	-45.04	-13.00	32.04	0
9	16920.00	-51.84	6.10	14.60	Vertical	-43.34	-13.00	30.34	90
10	18800.00	-	-	-	-	-	-	-	-

Note: 1. The other Spurious RF Radiated emissions level is no more than noise floor.
2. The worst emission was found in the antenna is Vertical position.



LTE Band 2 20MHz CH-Middle

Harmonic	Frequency (MHz)	SG (dBm)	Cable Loss (dB)	Gain (dBi)	Antenna Polarization	EIRP Level (dBm)	Limit (dBm)	Margin (dB)	Azimuth (deg)
2	3742.13	-63.61	2.60	12.50	Vertical	-53.71	-13.00	40.71	45
3	5613.38	-61.90	3.30	12.50	Vertical	-52.70	-13.00	39.70	0
4	7484.63	-50.50	4.20	12.20	Vertical	-42.50	-13.00	29.50	225
5	9400.00	-56.77	4.30	11.10	Vertical	-49.97	-13.00	36.97	45
6	11280.00	-51.59	5.90	11.90	Vertical	-45.59	-13.00	32.59	0
7	13160.00	-53.56	5.70	14.00	Vertical	-45.26	-13.00	32.26	45
8	15040.00	-52.51	5.80	13.10	Vertical	-45.21	-13.00	32.21	0
9	16920.00	-51.76	6.10	14.60	Vertical	-43.26	-13.00	30.26	90
10	18800.00	-	-	-	-	-	-	-	-

Note: 1. The other Spurious RF Radiated emissions level is no more than noise floor.

2. The worst emission was found in the antenna is Vertical position.



7. Main Test Instruments

Date of Testing: May 9, 2022 ~ May 13, 2022

Name	Manufacturer	Type	Serial Number	Calibration Date	Expiration Date
Wireless Communication Tester	Anritsu	MT8000A	6261844783	2021-05-15	2022-05-14
Wireless Communication Tester	Anritsu	MT8821C	6201538758	2021-05-15	2022-05-14
Climate Chamber	WEISS	VT 4002	58226119450010	2021-05-15	2022-05-14
Universal Radio Communication Tester	R&S	CMW500	150415	2021-05-15	2022-05-14
Spectrum Analyzer	Keysight	N9020A	MY52330084	2021-05-15	2022-05-14
Universal Radio Communication Tester	Agilent	E5515C	GB444400275	2021-05-15	2022-05-14
Universal Radio Communication Tester	StarPoint	SP9500	SP9500-20440	2021-05-15	2022-05-14
Spectrum Analyzer	R&S	FSV3030	101411	2021-12-12	2022-12-11
Spectrum Analyzer	R&S	FSV30	104028	2021-12-12	2022-12-11

Date of Testing: May 22, 2022

Name	Manufacturer	Type	Serial Number	Calibration Date	Expiration Date
Radiates Spurious Emission					
TRILOG Broadband Antenna	Schwarzbeck	VULB 9163	01111	2019-09-12	2022-09-11
Horn Antenna	Schwarzbeck	BBHA 9120D	1594	2020-12-17	2023-12-16
Loop Antenna	R&S	HM020E	101140	2021-06-07	2024-06-06
Horn Antenna	STEATITE	QSH-SL-26-40-K-15	16779	2019-12-24	2022-12-23
Software	R&S	EMC32	10.35.10	/	/

*****END OF REPORT *****



ANNEX A: The EUT Appearance

The EUT Appearance is submitted separately.



ANNEX B: Test Setup Photos

The Test Setup Photos is submitted separately.