

MONSTER®

ACHIEVE100 | AIRLINKS

Model No.:MH11901



Quick Guide

* please read this manual carefully and keep it for future use.

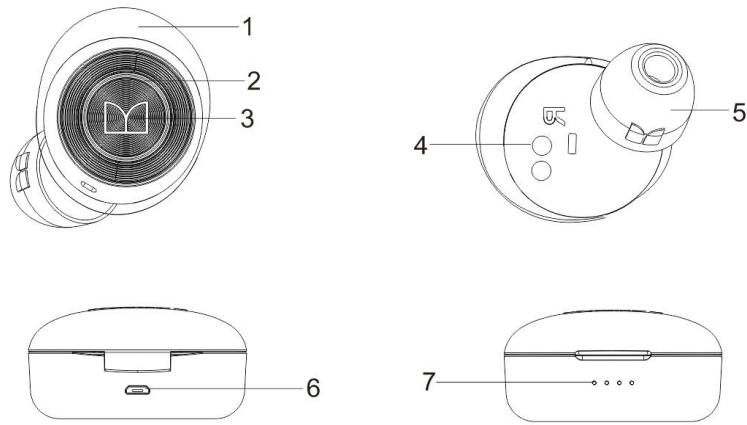

Product Overview:

- * Wireless Earbuds x 2 (Left & Right)
- * Charging Case
- * Earwings x 3 Pairs
- * Eartips x 3 Pairs
- * Micro USB Cable
- * User Manual & Letter of Guarantee

1. Ear fins
2. Multi-function Button (MFB)
3. LED Indicator Light
4. Charging Point
5. Eartips
6. Charging Case Charging Port
7. Charging Case LED

Power On/Off

Take the earbuds out of the charging case, and the earbuds will be automatically power on. When the earbuds is power on, put the earbuds into the charging case, and the earbuds can be power off and charging.

To try different sizes of ear tips to find comfortable sizes

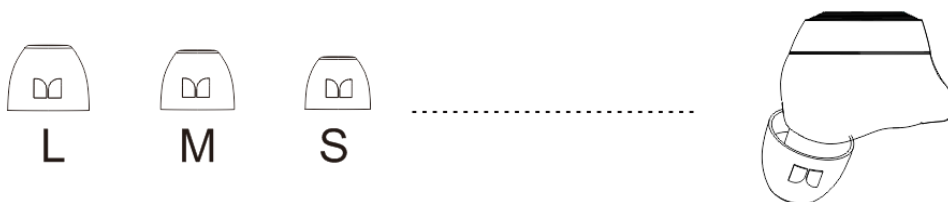

Rotate the earphone to wear the angle to make it wearable and comfortable

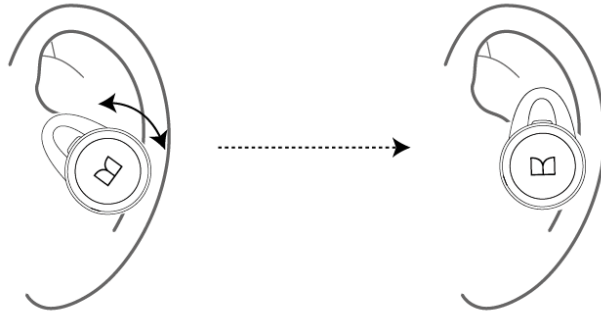

Pairing

Take out the left and right earbuds from the charging box, the earbuds will start automatically, and the L/R ears will entry pairing mode automatically. Then wait a few seconds, the L/R earbuds will connect with each other automatically , at the same time, you can hear the voice prompt of "pairing", then open the bluetooth of the phone, search device name "Clarity 102 AirLinks" to connection.

Volume Control

Double press Multi Function Buttons (R) to turn volume up.

Double press Multi Function Buttons (L) to turn volume down.

Calling

Answer/End Call: Short press MFB button to answer/end the phone call.

Reject Call: Long press MFB button about 2 seconds to reject phone call.

Music

Play/Pause Music: Short press MFB button to play/pause music.

Previous Track(Left earbud): Long press MFB button to 2 seconds.

Next Track(Right earbud): Long press MFB button 2 seconds.

Voice Control

Connected with the mobile phone, quick double click the MFB button to enter into the voice state

LED Indicator guide

Status	Description	Voice Prompt
Power On	Blue LED flash light about 1 second	"Power On"
Power Off	Red LED flash light about 1 second	"Power Off"
Pairing	Blue&Red LED flashes alternately	"Pairing"
Connect	Blue LED flash every 6 seconds	"Connected"
Charging	Red LED is bright when the earphone is charging	N/A

Attention Please

FULLY CHARGE before use.

DO NOT PRESS ANY KEY for pairing. Earbuds will go to pairing mode

Automatically after took out.

Put the earbuds in CORRECT POSITION for charging.

*If the battery is not replaced properly, there will be explosion risk. The battery can only be replaced with the same type or equivalent type of battery. It is not recommended to replace the battery without permission, but can be returned to the manufacturer for replacement.

*Batteries [battery packs or combination batteries] shall not be exposed to such conditions as lighting, baking, or similar overheating.

FCC Statement

FCC ID: 2AT2J-MH11901

Changes or modifications not expressly approved by the party responsible for compliance could void the user's authority to operate the equipment.

This equipment has been tested and found to comply with the limits for a Class B digital device, pursuant to Part 15 of the FCC Rules. These limits are designed to provide reasonable protection against harmful interference in a residential installation. This equipment generates uses and can radiate radio frequency energy and, if not installed and used in accordance with the instructions, may cause harmful interference to radio communications. However, there is no guarantee that interference will not occur in a particular installation. If this equipment does cause harmful interference to radio or television reception, which can be determined by turning the equipment off and on, the user is encouraged to try to correct the interference by one or more of the following measures:

- Reorient or relocate the receiving antenna.
- Increase the separation between the equipment and receiver.
- Connect the equipment into an outlet on a circuit different from that to which the receiver is connected.
- Consult the dealer or an experienced radio/TV technician for help

This device complies with part 15 of the FCC rules. Operation is subject to the following two conditions (1) this device may not cause harmful interference, and (2) this device must accept any interference received, including interference that may cause undesired operation.