



FCC PART 15.247 TEST REPORT

For

Shenzhen Adreamer Elite Co., Ltd.

Floor 4th, Fuannan industrial park, No. 1 Qingning road, Qinghu, Longhua Dist,
Shenzhen, China.

FCC ID: 2AT2FP206A

Report Type: Original Report	Product Type: Netbook
Report Number:	RSZ190603001-00B
Report Date:	2019-07-08
Reviewed By:	Nancy Wang  RF Engineer
Prepared By:	Bay Area Compliance Laboratories Corp. (Shenzhen) 6/F., West Wing, Third Phase of Wanli Industrial Building, Shihua Road, Futian Free Trade Zone, Shenzhen, Guangdong, China Tel: +86-755-33320018 Fax: +86-755-33320008 www.baclcorp.com.cn

Note: This report must not be used by the customer to claim product certification, approval, or endorsement by A2LA* or any agency of the Federal Government. * This report may contain data that are not covered by the A2LA accreditation and are marked with an asterisk “*”.

The information marked # is provided by the applicant, the laboratory is not responsible for its authenticity.

TABLE OF CONTENTS

GENERAL INFORMATION	4
PRODUCT DESCRIPTION FOR EQUIPMENT UNDER TEST (EUT).....	4
OBJECTIVE	4
RELATED SUBMITTAL(S)/GRANT(S).....	4
TEST METHODOLOGY	4
MEASUREMENT UNCERTAINTY.....	5
TEST FACILITY	5
SYSTEM TEST CONFIGURATION	6
DESCRIPTION OF TEST CONFIGURATION	6
EUT EXERCISE SOFTWARE	6
SPECIAL ACCESSORIES.....	6
EQUIPMENT MODIFICATIONS	6
BLOCK DIAGRAM OF TEST SETUP	7
SUMMARY OF TEST RESULTS	8
TEST EQUIPMENT LIST	9
FCC§15.247 (i), §1.1307 (b) (1) &§2.1093 – RF EXPOSURE	11
APPLICABLE STANDARD	11
FCC §15.203 – ANTENNA REQUIREMENT	12
APPLICABLE STANDARD	12
ANTENNA CONNECTOR CONSTRUCTION	12
FCC §15.207 (a) – AC LINE CONDUCTED EMISSIONS	13
APPLICABLE STANDARD	13
EUT SETUP	13
EMI TEST RECEIVER SETUP.....	13
TEST PROCEDURE	13
CORRECTED FACTOR & MARGIN CALCULATION	14
TEST RESULTS SUMMARY	14
TEST DATA	14
FCC §15.205, §15.209 & §15.247(d) – RADIATED EMISSIONS	17
APPLICABLE STANDARD	17
EUT SETUP	17
EMI TEST RECEIVER & SPECTRUM ANALYZER SETUP	18
TEST PROCEDURE	18
CORRECTED AMPLITUDE & MARGIN CALCULATION	18
TEST RESULTS SUMMARY	18
TEST DATA	19
FCC §15.247(a) (1)-CHANNEL SEPARATION TEST	25
APPLICABLE STANDARD	25
TEST PROCEDURE	25
TEST DATA	25

FCC §15.247(a) (1) – 20 dB EMISSION BANDWIDTH.....32
 APPLICABLE STANDARD32
 TEST PROCEDURE32
 TEST DATA32

FCC §15.247(a) (1) (iii)-QUANTITY OF HOPPING CHANNEL TEST38
 APPLICABLE STANDARD38
 TEST PROCEDURE38
 TEST DATA38

FCC §15.247(a) (1) (iii) - TIME OF OCCUPANCY (DWELL TIME).....41
 APPLICABLE STANDARD41
 TEST PROCEDURE41
 TEST DATA41

FCC §15.247(b) (1) - PEAK OUTPUT POWER MEASUREMENT57
 APPLICABLE STANDARD57
 TEST PROCEDURE57
 TEST DATA57

FCC §15.247(d) - BAND EDGES TESTING58
 APPLICABLE STANDARD58
 TEST PROCEDURE58
 TEST DATA58

GENERAL INFORMATION

Product Description for Equipment under Test (EUT)

Product	Netbook
Tested Model	P206
Frequency Range	Bluetooth: 2402~2480MHz
Transmit Power	Bluetooth: 5.45dBm
Modulation Technique	Bluetooth: GFSK, $\pi/4$ -DQPSK, 8DPSK
Antenna Specification	FPC Antenna: 4.5dBi
Voltage Range	DC 7.6 V from battery or DC 12V from adapter
Date of Test	2019-06-18~2019-07-05
Sample serial number	190603001
Received date	2019-06-03
Sample/EUT Status	Good condition
Adapter information	Model: JHD-AP024U-120200BA-A Input: AC 100-240V, 50/60Hz, 0.45A Output: DC 12V, 2000mA

Objective

This test report is prepared on behalf of *ShenzhenAdreamerEliteCo.,Ltd.* in accordance with Part 2-Subpart J, Part 15-Subparts A and C of the Federal Communication Commissions rules.

The tests were performed in order to determine compliance with FCC Part 15, Subpart C, section 15.203, 15.205, 15.207, 15.209 and 15.247 rules.

Related Submittal(s)/Grant(s)

FCC Part 15.247 DTS and Part 15.407 NII submissions with FCC ID: 2AT2FP206A.

Test Methodology

All measurements contained in this report were conducted with ANSI C63.10-2013, American National Standard of Procedures for Compliance Testing of Unlicensed Wireless Devices.

And KDB 558074 D01 15.247 Meas Guidance v05r02.

All emissions measurement was performed at Bay Area Compliance Laboratories Corp. (Shenzhen). The radiated testing was performed at an antenna-to-EUT distance of 3 meters.

Measurement Uncertainty

Parameter		Uncertainty
Occupied Channel Bandwidth		±5%
RF Output Power with Power meter		±0.73dB
RF conducted test with spectrum		±1.6dB
AC Power Lines Conducted Emissions		±1.95dB
Emissions, Radiated	Below 1GHz	±4.75dB
	Above 1GHz	±4.88dB
Temperature		±1°C
Humidity		±6%
Supply voltages		±0.4%

Note: Otherwise required by the applicant or Product Regulations, Decision Rule in this report did not consider the uncertainty.

Test Facility

The Test site used by Bay Area Compliance Laboratories Corp. (Shenzhen) to collect test data is located on the 6/F., West Wing, Third Phase of Wanli Industrial Building, Shihua Road, Futian Free Trade Zone, Shenzhen, Guangdong, China.

The test site has been approved by the FCC under the KDB 974614 D01 and is listed in the FCC Public Access Link (PAL) database, FCC Registration No.: 342867, the FCC Designation No.: CN1221.

The test site has been registered with ISED Canada under ISED Canada Registration Number 3062B.

SYSTEM TEST CONFIGURATION

Description of Test Configuration

The system was configured for testing in an engineering mode.

EUT Exercise Software

Exercise software DRTU.EXE was made to the EUT tested, and the power level is default.

Special Accessories

No special accessory.

Equipment Modifications

No modification was made to the EUT tested.

Support Equipment List and Details :

Manufacturer	Description	Model	Serial Number
N/A	Earphone	N/A	N/A
Kingston	SD Card	1 GB	201
SAMSUNG	Monitor	225MS	CR22HVZP401073M
DELL	Monitor	ST2420Lb	CN-0X0K27-74261-2AF-090U
Microsoft	Keyboard	1406	0200706128743
DELL	Mouse	1405	MOC5UO

External I/O Cable

Cable Description	Length (m)	From/Port	To
Un-Shielding Detachable DC Cable	2.0	Adapter	EUT
Un-shielding Detachable HDMI Cable	1.2	Monitor(HDMI)	EUT

Block Diagram of Test Setup

For conducted emission

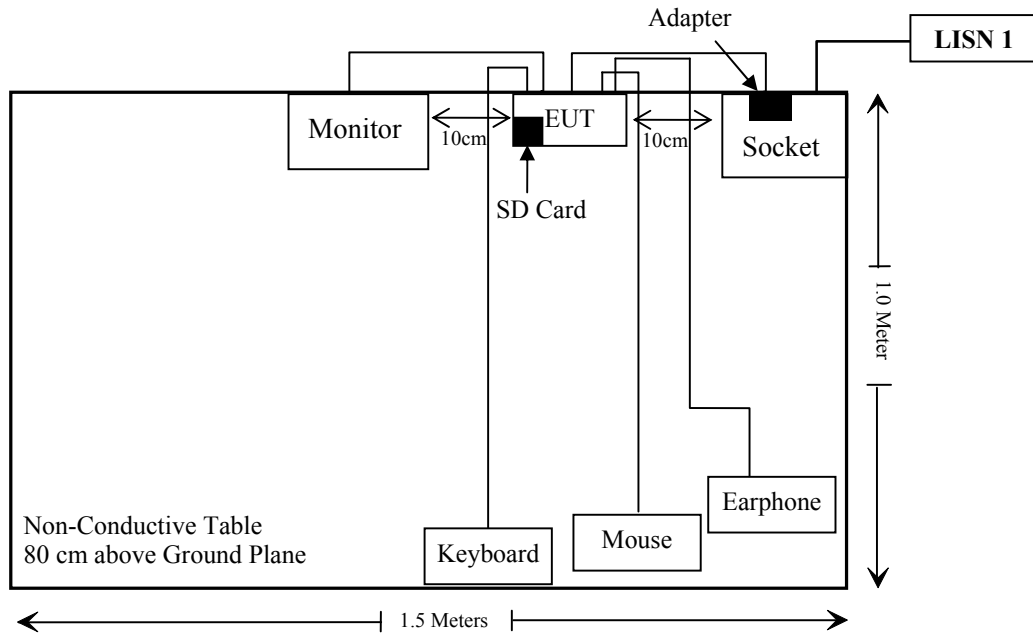

SUMMARY OF TEST RESULTS

FCC Rules	Description of Test	Result
§15.247 (i), §1.1307 (b) (1)& §2.1093	RF Exposure	Compliance
§15.203	Antenna Requirement	Compliance
§15.207(a)	AC Line Conducted Emissions	Compliance
§15.205, §15.209 & §15.247(d)	Radiated Emissions	Compliance
§15.247(a)(1)	20 dB Emission Bandwidth	Compliance
§15.247(a)(1)	Channel Separation Test	Compliance
§15.247(a)(1)(iii)	Time of Occupancy (Dwell Time)	Compliance
§15.247(a)(1)(iii)	Quantity of hopping channel Test	Compliance
§15.247(b)(1)	Peak Output Power Measurement	Compliance
§15.247(d)	Band edges	Compliance

TEST EQUIPMENT LIST

Manufacturer	Description	Model	Serial Number	Calibration Date	Calibration Due Date
Conducted Emissions Test					
Rohde & Schwarz	EMI Test Receiver	ESCS30	100176	2018-07-11	2019-07-11
Rohde & Schwarz	LISN	ENV216	3560.6650.12-101613-Yb	2019-01-25	2020-01-25
Rohde & Schwarz	Transient Limiter	ESH3Z2	DE25985	2019-03-02	2020-03-02
Rohde & Schwarz	CE Test software	EMC 32	V8.53.0	NCR	NCR
Un-known	Conducted Emission Cable	78652	UF A210B-1-0720-504504	2018-11-12	2019-11-12
Radiated Emission Test					
A.H. System	Horn Antenna	SAS-200/571	135	2018-09-01	2021-08-31
Rohde & Schwarz	Signal and Spectrum Analyzer	FSV40-N	102259	2019-06-22	2020-06-22
Sunol Sciences	Broadband Antenna	JB1	A040904-1	2017-12-22	2020-12-21
COM-POWER	Pre-amplifier	PA-122	181919	2018-11-12	2019-11-12
Sonoma Instrument	Amplifier	310N	186238	2018-11-12	2019-11-12
Rohde & Schwarz	EMI Test Receiver	ESR	1316.3003K03-101746-zn	2018-07-11	2019-07-11
Ducommun technologies	RF Cable	UFA147A-2362-100100	MFR64639-231029-003	2018-11-12	2019-11-12
Ducommun technologies	RF Cable	104PEA	218124002	2018-11-12	2019-11-12
Ducommun technologies	RF Cable	RG-214	1	2018-11-12	2019-11-12
Ducommun technologies	RF Cable	RG-214	2	2018-11-12	2019-11-12
Ducommun Technologies	Horn Antenna	ARH-4223-02	1007726-04	2017-12-29	2020-12-28
Heatsink Required	Amplifier	QLW-18405536-J0	15964001002	2018-11-12	2019-11-12
Sinoscite	Notch Filter	BSF2402-2480MN-0898-001	99632	2018-11-12	2019-11-12
Rohde & Schwarz	Auto test software	EMC 32	V9.10	NCR	NCR

Manufacturer	Description	Model	Serial Number	Calibration Date	Calibration Due Date
RF Conducted Test					
Agilent	USB wideband power meter	U2021XA	MY54250003	2018-06-23	2019-06-23
WEINSCHTEL	3dB Attenuator	6231	666	Each Time	
Rohde & Schwarz	Spectrum Analyzer	FSU26	200120	2019-03-02	2020-03-01
Ducommun technologies	RF Cable	RG-214	3	Each Time	

* **Statement of Traceability:** Bay Area Compliance Laboratories Corp. (Shenzhen) attests that all calibrations have been performed in accordance to requirements that traceable to National Primary Standards and International System of Units (SI).

FCC§15.247 (i), §1.1307 (b) (1) &§2.1093 – RF EXPOSURE

Applicable Standard

According to FCC §2.1093 and §1.1307(b) (1), systems operating under the provisions of this section shall be operated in a manner that ensure that the public is not exposed to radio frequency energy level in excess of the Commission’s guideline.

According to KDB 447498 D01 General RF Exposure Guidance

The 1-g and 10-g SAR test exclusion thresholds for 100 MHz to 6 GHz at test separation distances ≤ 50 mm are determined by:

$$[(\text{max. power of channel, including tune-up tolerance, mW})/(\text{min. test separation distance, mm})] \cdot [\sqrt{f(\text{GHz})}] \leq 3.0 \text{ for 1-g SAR and } \leq 7.5 \text{ for 10-g extremity SAR, where}$$

1. f(GHz) is the RF channel transmit frequency in GHz.
2. Power and distance are rounded to the nearest mW and mm before calculation.
3. The result is rounded to one decimal place for comparison.
4. When the minimum test separation distance is < 5 mm, a distance of 5 mm is applied to determine SAR test Exclusion.

For worst case:

Frequency (MHz)	Maximum Tune-up power		Calculated Distance (mm)	Calculated Value	Threshold (1-g SAR)	SAR Test Exclusion
	(dBm)	(mW)				
2480	5.5	3.55	5	1.1	3.0	Yes

Result: No Standalone SAR test is required

FCC §15.203 – ANTENNA REQUIREMENT

Applicable Standard

According to FCC § 15.203, an intentional radiator shall be designed to ensure that no antenna other than that furnished by the responsible party shall be used with the device. The use of a permanently attached antenna or of an antenna that uses a unique coupling to the intentional radiator shall be considered sufficient to comply with the provisions of this Section. The manufacturer may design the unit so that a broken antenna can be replaced by the user, but the use of a standard antenna jack or electrical connector is prohibited.

Antenna Connector Construction

The EUT has one internal antenna arrangement, which was permanently attached and the antenna gain is 4.5 dBi, fulfill the requirement of this section. Please refer to the EUT photos.

Result: Compliance.

FCC §15.207 (a) – AC LINE CONDUCTED EMISSIONS

Applicable Standard

FCC §15.207(a)

EUT Setup

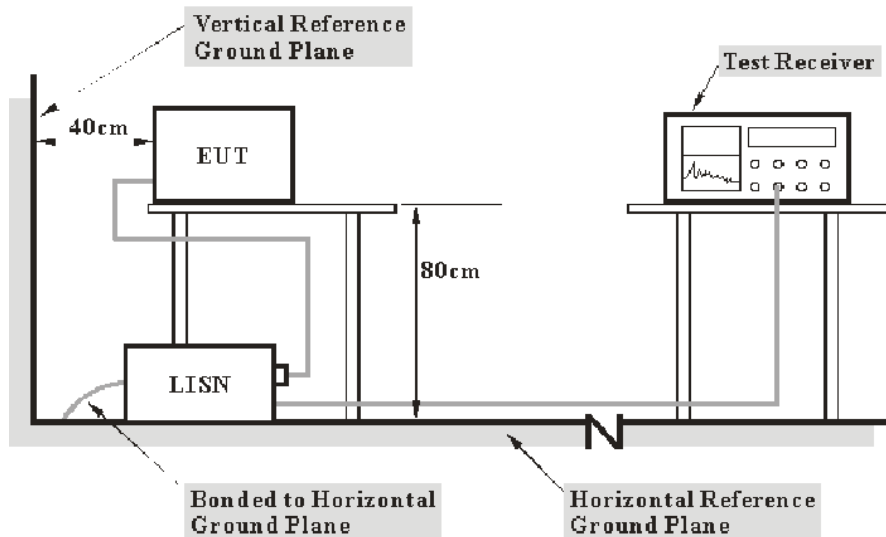

- Note: 1. Support units were connected to second LISN.
 2. Both of LISNs (AMN) 80 cm from EUT and at the least 80 cm from other units and other metal planes support units.

The measurement procedure of EUT setup is according with ANSI C63.10-2013. The related limit was specified in FCC Part 15.207.

The spacing between the peripherals was 10 cm.

EMI Test Receiver Setup

The EMI test receiver was set to investigate the spectrum from 150 kHz to 30 MHz.

During the conducted emission test, the EMI test receiver was set with the following configurations:

Frequency Range	IF B/W
150 kHz – 30 MHz	9 kHz

Test Procedure

During the conducted emission test, the adapter was connected to the outlet of the LISN.

Maximizing procedure was performed on the six (6) highest emissions of the EUT.

All final data was recorded in the Quasi-peak and average detection mode.

Corrected Factor & Margin Calculation

The Corrected factor is calculated by adding LISN VDF (Voltage Division Factor), Cable Loss and Transient Limiter Attenuation. The basic equation is as follows:

$$\text{Correction Factor} = \text{LISN VDF} + \text{Cable Loss} + \text{Transient Limiter Attenuation}$$

The “**Margin**” column of the following data tables indicates the degree of compliance with the applicable limit. For example, a margin of 7 dB means the emission is 7 dB below the limit. The equation for margin calculation is as follows:

$$\text{Margin} = \text{Limit} - \text{Corrected Amplitude}$$

Test Results Summary

According to the recorded data in following table, the EUT complied with the FCC Part 15.207,

Refer to CISPR16-4-2:2011 and CISPR 16-4-1:2009, the measured level complies with the limit if

$$L_m + U_{(L_m)} \leq L_{\text{lim}} + U_{\text{cispr}}$$

In BACL, $U_{(L_m)}$ is less than U_{cispr} , if L_m is less than L_{lim} , it implies that the EUT complies with the limit.

Test Data

Environmental Conditions

Temperature:	25 °C
Relative Humidity:	50 %
ATM Pressure:	101.0 kPa

The testing was performed by Haiguo Li on 2019-06-18.

EUT operation mode: Transmitting & charging (the worst case is GFSK Mode, High channel)

AC 120V/60 Hz, Line

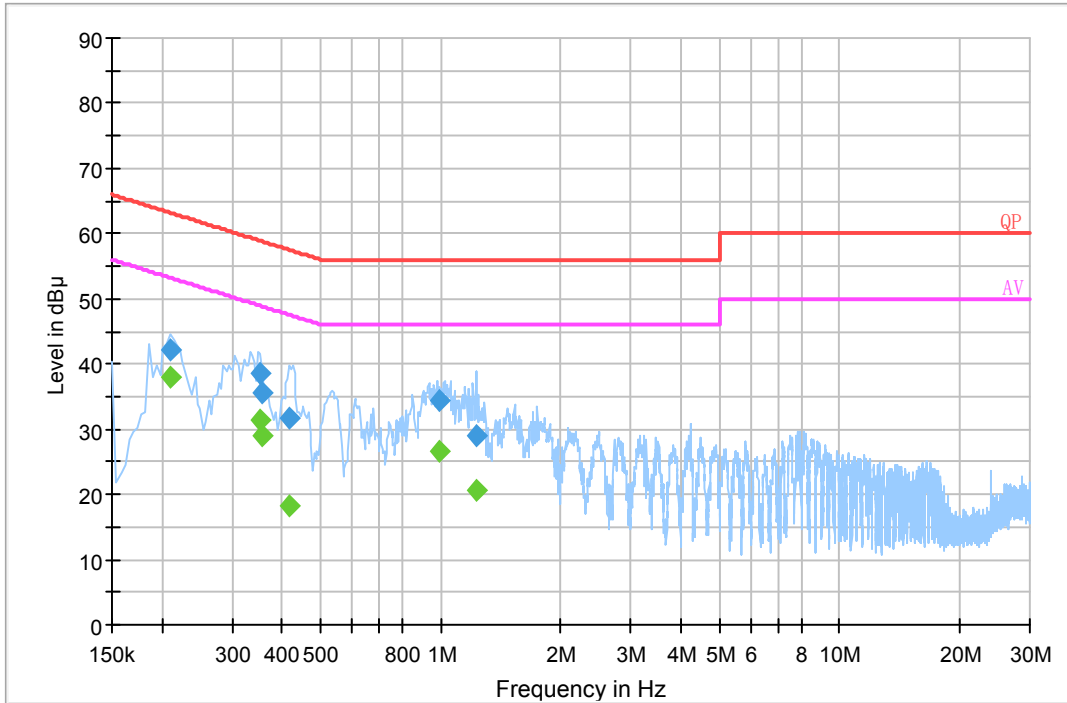

Frequency (MHz)	Corrected Amplitude (dBµV)	Correction Factor (dB)	Limit (dBµV)	Margin (dB)	Detector (PK/Ave./QP)
0.209500	42.2	19.8	63.2	21.0	QP
0.352750	38.5	19.9	58.9	20.4	QP
0.356690	35.6	19.9	58.8	23.2	QP
0.419610	31.8	19.9	57.5	25.7	QP
0.991270	34.5	19.9	56.0	21.5	QP
1.227550	29.0	19.8	56.0	27.0	QP
0.209500	38.0	19.8	53.2	15.2	Ave.
0.352750	31.4	19.9	48.9	17.5	Ave.
0.356690	29.0	19.9	48.8	19.8	Ave.
0.419610	18.3	19.9	47.5	29.2	Ave.
0.991270	26.7	19.9	46.0	19.3	Ave.
1.227550	20.8	19.8	46.0	25.2	Ave.

AC 120V/60 Hz, Neutral

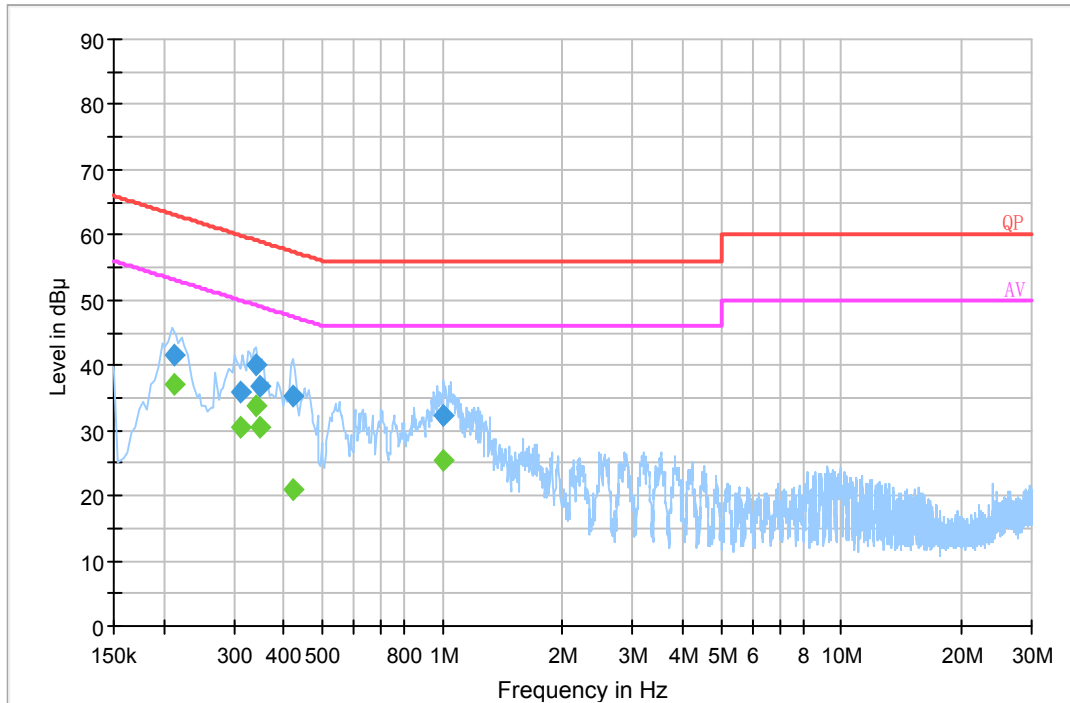

Frequency (MHz)	Corrected Amplitude (dBμV)	Correction Factor (dB)	Limit (dBμV)	Margin (dB)	Detector (PK/Ave./QP)
0.213500	41.5	19.8	63.1	21.6	QP
0.313290	35.8	19.7	59.9	24.1	QP
0.340870	40.0	19.8	59.2	19.2	QP
0.348690	36.6	19.9	59.0	22.4	QP
0.423670	35.3	19.8	57.4	22.1	QP
1.006910	32.2	19.8	56.0	23.8	QP
0.213500	37.2	19.8	53.1	15.9	Ave.
0.313290	30.3	19.7	49.9	19.6	Ave.
0.340870	33.7	19.8	49.2	15.5	Ave.
0.348690	30.5	19.9	49.0	18.5	Ave.
0.423670	20.8	19.8	47.4	26.6	Ave.
1.006910	25.5	19.8	46.0	20.5	Ave.

Note:

- 1) Correction Factor = LISN VDF (Voltage Division Factor) + Cable Loss + Transient Limiter Attenuation
- 2) Corrected Amplitude = Reading + Correction Factor
- 3) Margin = Limit – Corrected Amplitude

FCC §15.205, §15.209 & §15.247(d) – RADIATED EMISSIONS

Applicable Standard

FCC §15.205; §15.209; §15.247(d)

EUT Setup

Below 1 GHz:

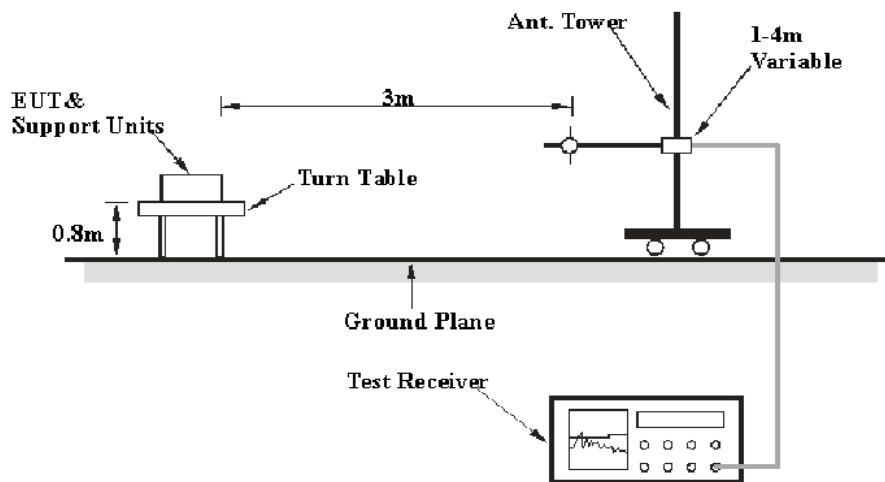

Above 1GHz:

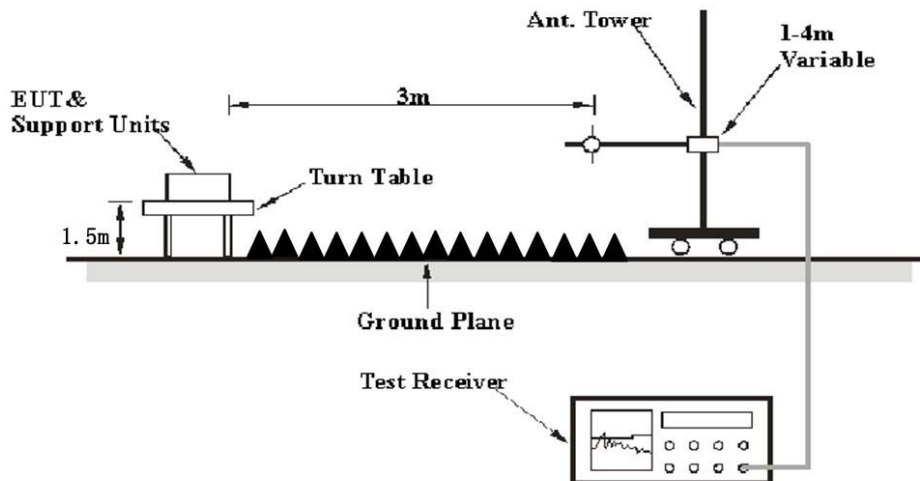

The radiated emission tests were performed in the 3 meters, using the setup accordance with the ANSI C63.10-2013. The specification used was the FCC 15.209 and FCC 15.247 limits.

EMI Test Receiver & Spectrum Analyzer Setup

The system was investigated from 30 MHz to 25 GHz.

During the radiated emission test, according to the DA 00-705 Released March 30, 2000, the EMI test receiver & Spectrum Analyzer Setup were set with the following configurations:

Frequency Range	RBW	Video B/W	IF B/W	Measurement
30 MHz – 1000 MHz	100 kHz	300 kHz	120 kHz	QP
Above 1 GHz	1 MHz	3 MHz	/	PK
	1 MHz	10 Hz	/	Average

Test Procedure

Maximizing procedure was performed on the highest emissions to ensure that the EUT complied with all installation combinations.

All final data was recorded in Quasi-peak detection mode for frequency range of 30 MHz -1 GHz and peak and Average detection modes for frequencies above 1 GHz.

Corrected Amplitude & Margin Calculation

The Corrected Amplitude is calculated by adding the Antenna Factor and Cable Loss, and subtracting the Amplifier Gain from the Meter Reading. The basic equation is as follows:

$$\text{Corrected Amplitude} = \text{Meter Reading} + \text{Antenna Factor} + \text{Cable Loss} - \text{Amplifier Gain}$$

The “**Margin**” column of the following data tables indicates the degree of compliance with the applicable limit. For example, a margin of 7dB means the emission is 7dB below the limit. The equation for margin calculation is as follows:

$$\text{Margin} = \text{Limit} - \text{Corrected Amplitude}$$

Test Results Summary

According to the recorded data in following table, the EUT complied with the FCC Title 47, Part 15, Subpart C, section 15.205, 15.209 and 15.247.

Refer to CISPR16-4-2:2011 and CISPR 16-4-1:2009, the measured level complies with the limit if

$$L_m + U_{(L_m)} \leq L_{\text{lim}} + U_{\text{cispr}}$$

In BAEL, $U_{(L_m)}$ is less than U_{cispr} , if L_m is less than L_{lim} , it implies that the EUT complies with the limit.

Test Data

Environmental Conditions

Temperature:	25 °C
Relative Humidity:	56 %
ATM Pressure:	101.0 kPa

The testing was performed by Andy Yu and Alan He on 2019-06-21 and 2019-06-24.

EUT operation mode: Transmitting (Scan with GFSK, $\pi/4$ -DQPSK, 8DPSK mode, the worst case is GFSK Mode)

30 MHz~1 GHz: (the worst case is GFSK Mode, High channel)

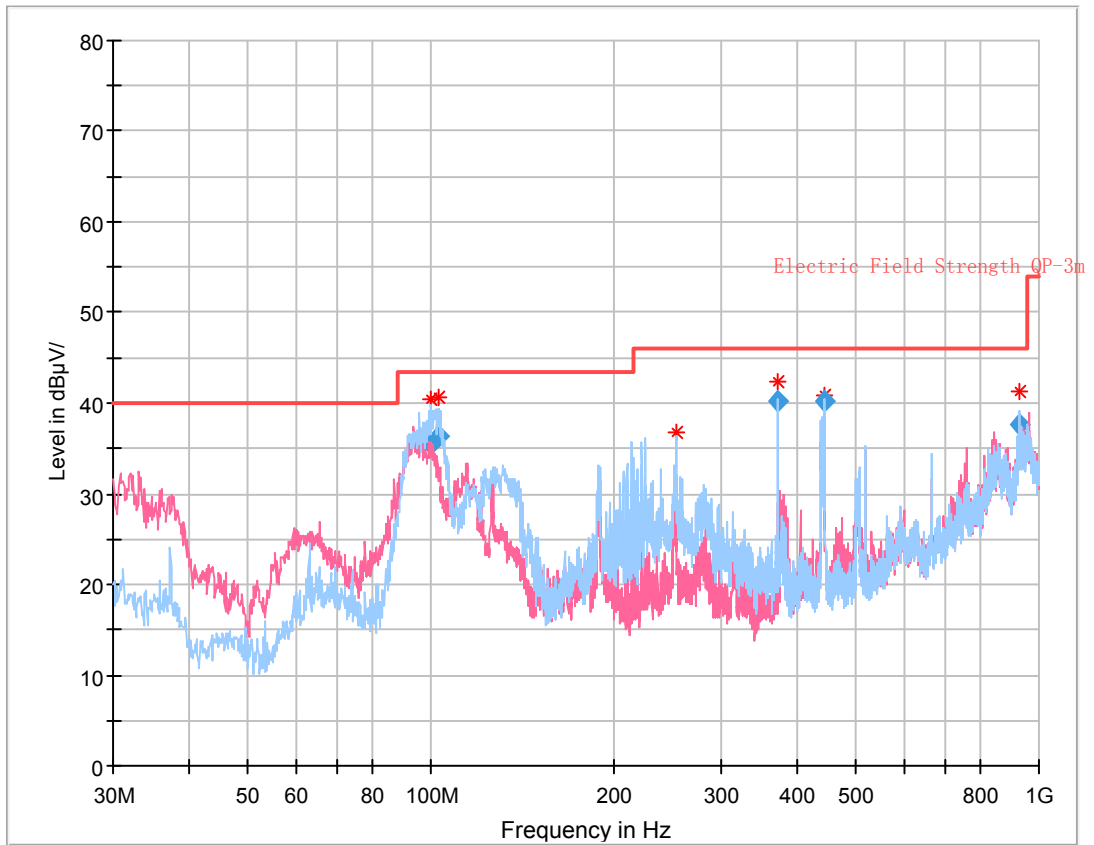

Frequency (MHz)	Corrected Amplitude (dBμV/m)	Antenna height (cm)	Antenna Polarity	Turntable position (degree)	Correction Factor (dB/m)	Limit (dBμV/m)	Margin (dB)
100.140875	35.42	176.0	H	232.0	-17.2	43.50	8.08
102.869250	36.24	235.0	H	242.0	-16.7	43.50	7.26
253.942250	25.98	122.0	H	136.0	-13.8	46.00	20.02
370.882500	40.13	109.0	H	212.0	-10.6	46.00	5.87
443.657875	40.14	126.0	H	277.0	-8.5	46.00	5.86
927.159000	37.55	172.0	H	242.0	7.3	46.00	8.45

1 GHz - 25 GHz:

Frequency (MHz)	Receiver		Turntable Degree	Rx Antenna		Corrected Factor (dB/m)	Corrected Amplitude (dBμV/m)	Limit (dBμV/m)	Margin (dB)
	Reading (dBμV)	PK/QP/Ave.		Height (m)	Polar (H/V)				
Low Channel (2402 MHz)									
2358.10	28.37	PK	264	1.6	H	31.77	60.14	74	13.86
2358.10	13.94	Ave.	264	1.6	H	31.77	45.71	54	8.29
2494.74	29.27	PK	12	2.4	H	32.13	61.40	74	12.60
2494.74	13.75	Ave.	12	2.4	H	32.13	45.88	54	8.12
4804.00	43.68	PK	316	2.4	H	6.28	49.96	74	24.04
4804.00	28.15	Ave.	316	2.4	H	6.28	34.43	54	19.57
Middle Channel (2441 MHz)									
4882.00	43.35	PK	68	2.2	H	6.76	50.11	74	23.89
4882.00	27.75	Ave.	68	2.2	H	6.76	34.51	54	19.49
High Channel (2480 MHz)									
2310.98	28.87	PK	30	1.5	H	31.64	60.51	74	13.49
2310.98	13.65	Ave.	30	1.5	H	31.64	45.29	54	8.71
2486.81	28.90	PK	348	1.0	H	32.13	61.03	74	12.97
2486.81	13.91	Ave.	348	1.0	H	32.13	46.04	54	7.96
4960.00	43.42	PK	356	2.1	H	6.80	50.22	74	23.78
4960.00	28.19	Ave.	356	2.1	H	6.80	34.99	54	19.01

Note:

Corrected Factor = Antenna factor (RX) + Cable Loss – Amplifier Factor

Corrected Amplitude = Corrected Factor + Reading

Margin = Limit - Corrected. Amplitude

The other spurious emission which is 20dB to the limit was not recorded.

And for the pre-scan is performed with the 2400-2483.5MHz band filter.

**Pre-scan with High channel Peak
Horizontal**

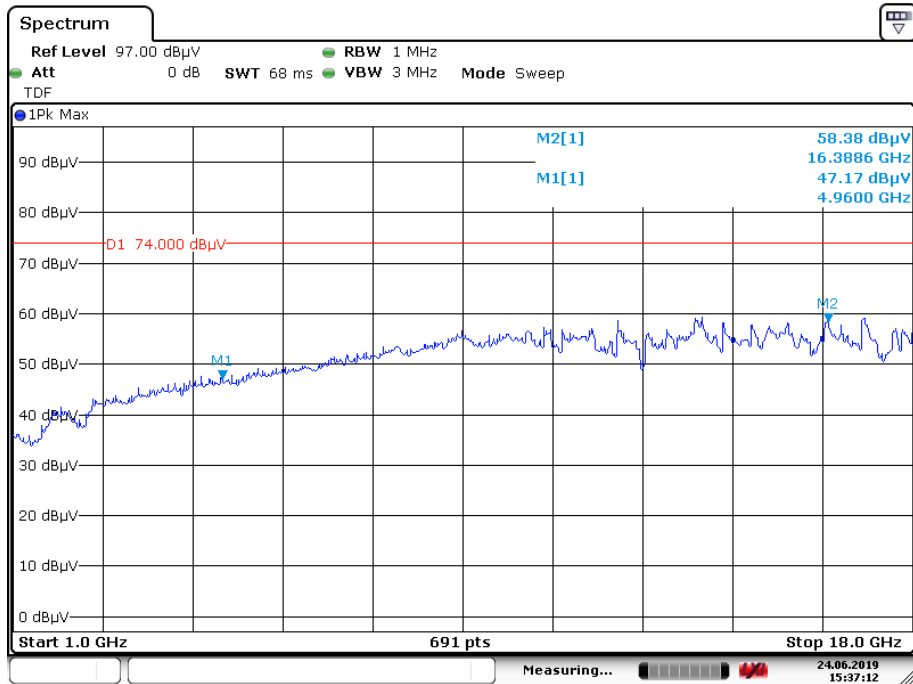

Date: 24.JUN.2019 15:37:12

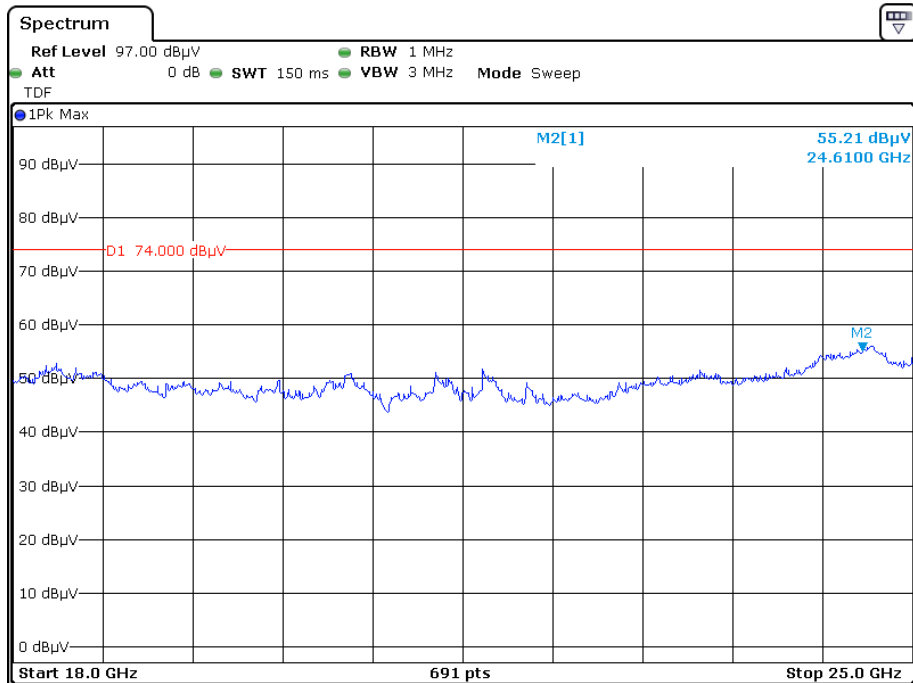

Date: 24.JUN.2019 16:28:39

Vertical

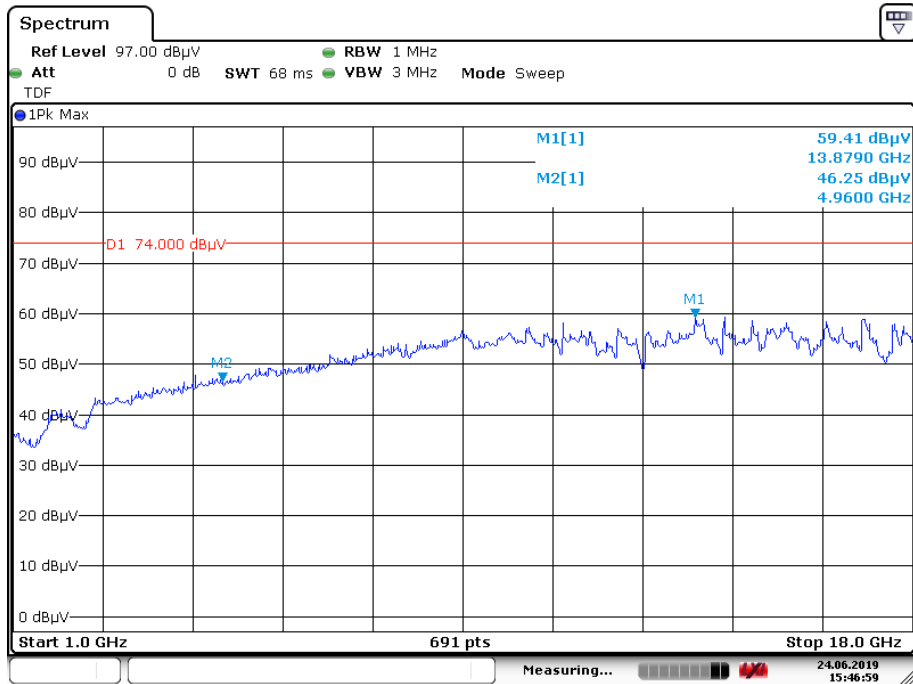

Date: 24.JUN.2019 15:46:58

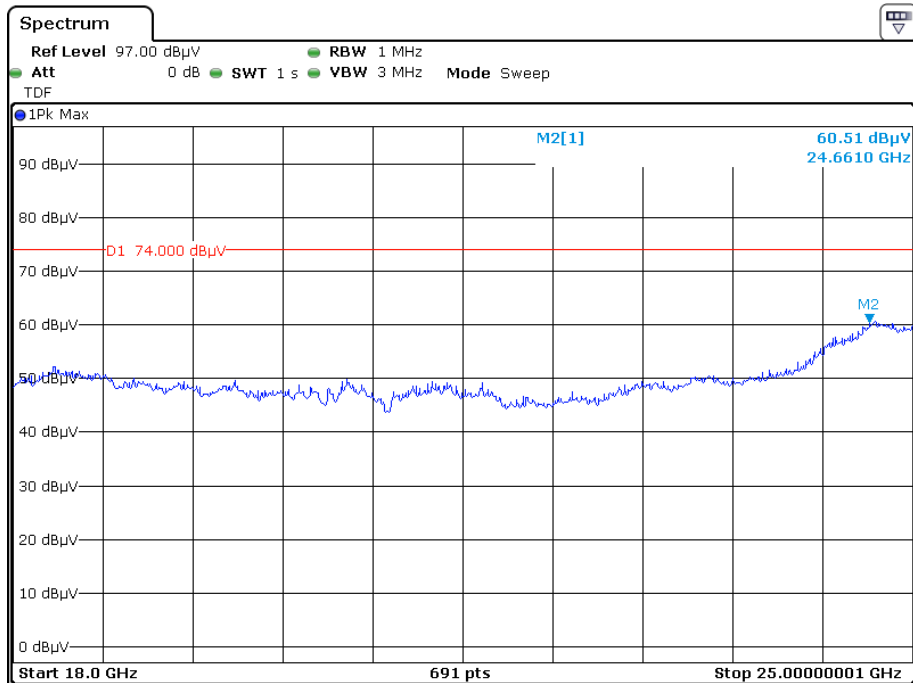

Date: 24.JUN.2019 16:41:47

Pre-scan for Average Horizontal

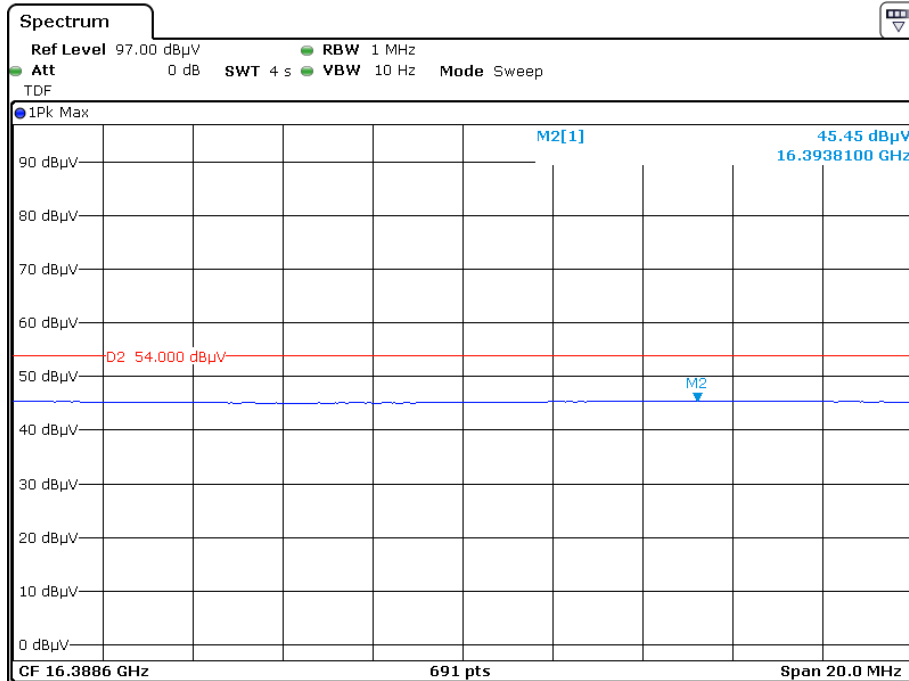

Date: 24.JUN.2019 15:42:22

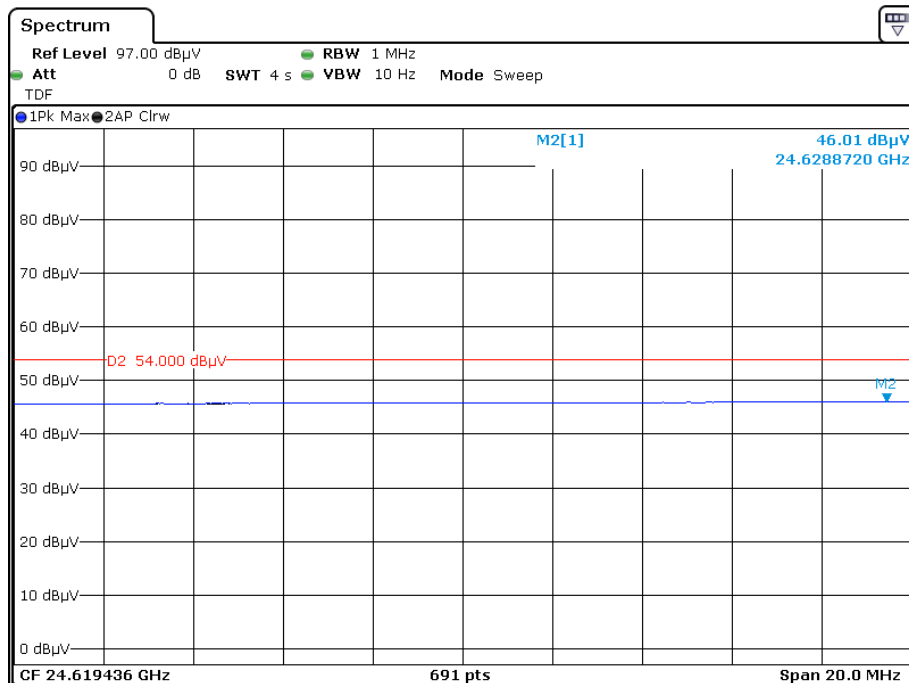

Date: 24.JUN.2019 16:36:13

Vertical

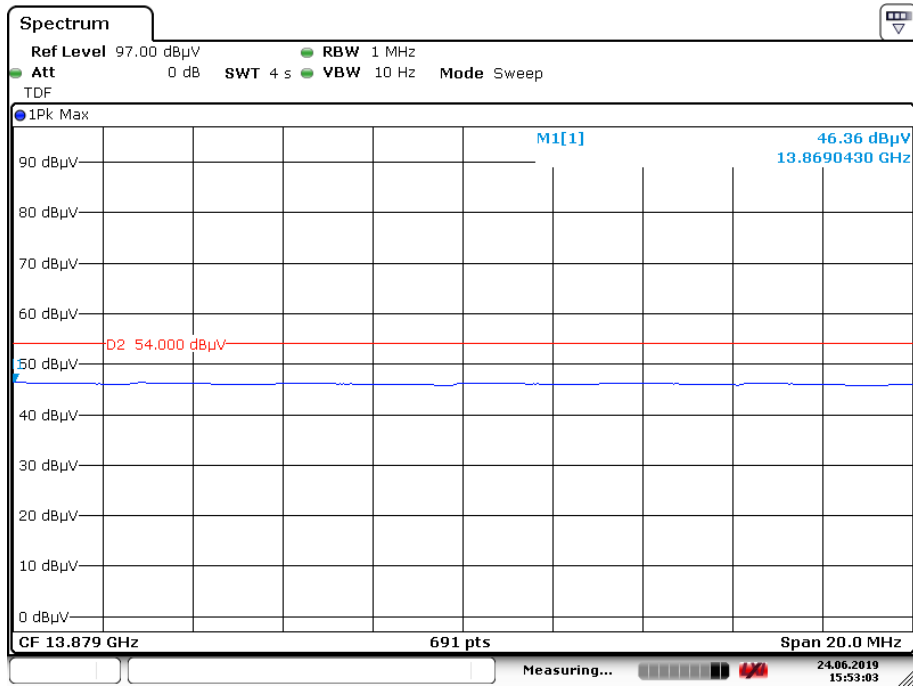

Date: 24.JUN.2019 15:53:03

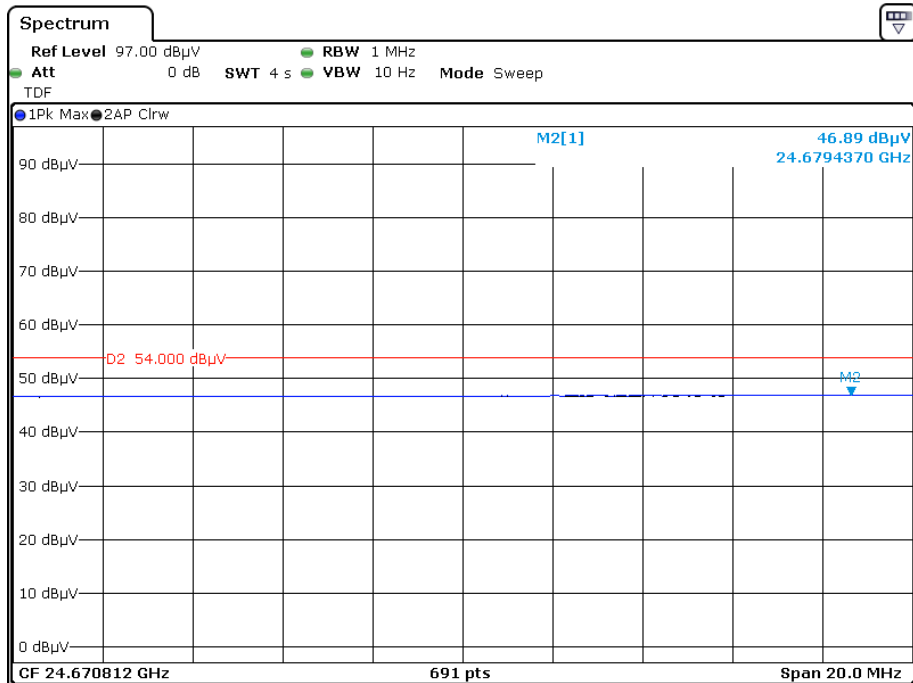

Date: 24.JUN.2019 16:48:11

FCC §15.247(a) (1)-CHANNEL SEPARATION TEST

Applicable Standard

Frequency hopping systems shall have hopping channel carrier frequencies separated by a minimum of 25 kHz or the 20 dB bandwidth of the hopping channel, whichever is greater. Alternatively, frequency hopping systems operating in the 2400-2483.5 MHz band may have hopping channel carrier frequencies that are separated by 25 kHz or two-thirds of the 20 dB bandwidth of the hopping channel, whichever is greater provided the systems operate with an output power no greater than 125 mW. The system shall hop to channel frequencies that are selected at the system hopping rate from a pseudo randomly ordered list of hopping frequencies. Each frequency must be used equally on the average by each transmitter. The system receivers shall have input bandwidths that match the hopping channel bandwidths of their corresponding transmitters and shall shift frequencies in synchronization with the transmitted signals.

Test Procedure

1. Set the EUT in transmitting mode, maxhold the channel.
2. Set the adjacent channel of the EUT and maxhold another trace.
3. Measure the channel separation.

Test Data

Environmental Conditions

Temperature:	25°C
Relative Humidity:	55 %
ATM Pressure:	101.0 kPa

The testing was performed by Leo Huang on 2019-06-19.

EUT operation mode: Transmitting

Test Result: Compliance. Please refer to following table and plots.

Channel	Channel Separation (MHz)	20 dBc BW (MHz)	Two-thirds of the 20 dB bandwidth (MHz)	Channel Separation Limit	Result
BDR(GFSK)					
Low	1.004	0.929	0.619	> two-thirds of the 20 dB bandwidth	Compliance
Middle	0.988	0.927	0.618	> two-thirds of the 20 dB bandwidth	Compliance
High	1.000	0.934	0.623	> two-thirds of the 20 dB bandwidth	Compliance
EDR($\pi/4$-DQPSK)					
Low	0.992	1.450	0.967	> two-thirds of the 20 dB bandwidth	Compliance
Middle	0.996	1.455	0.970	> two-thirds of the 20 dB bandwidth	Compliance
High	1.008	1.455	0.970	> two-thirds of the 20 dB bandwidth	Compliance
EDR(8DPSK)					
Low	0.992	1.458	0.972	> two-thirds of the 20 dB bandwidth	Compliance
Middle	1.008	1.455	0.970	> two-thirds of the 20 dB bandwidth	Compliance
High	1.008	1.460	0.973	> two-thirds of the 20 dB bandwidth	Compliance

Please refer to the following plots.

BDR (GFSK): Low Channel

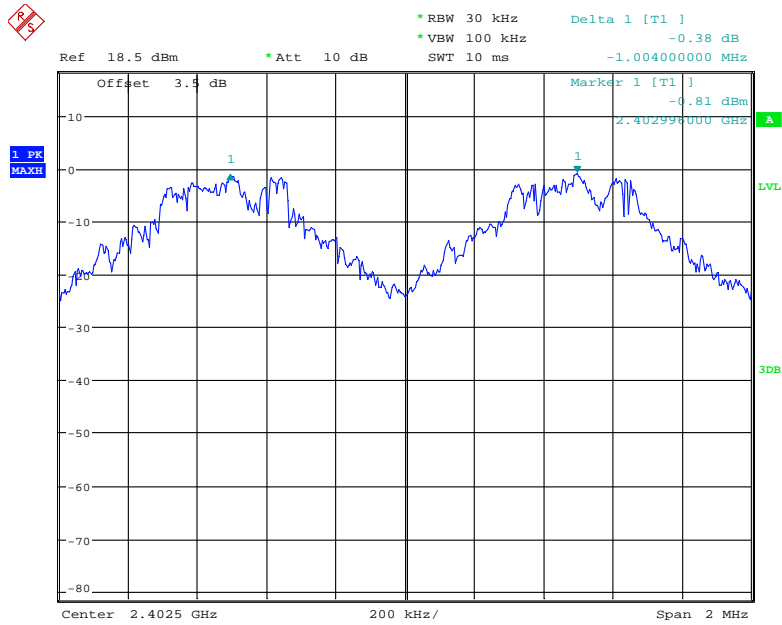

Date: 19.JUN.2019 15:49:23

BDR (GFSK): Middle Channel

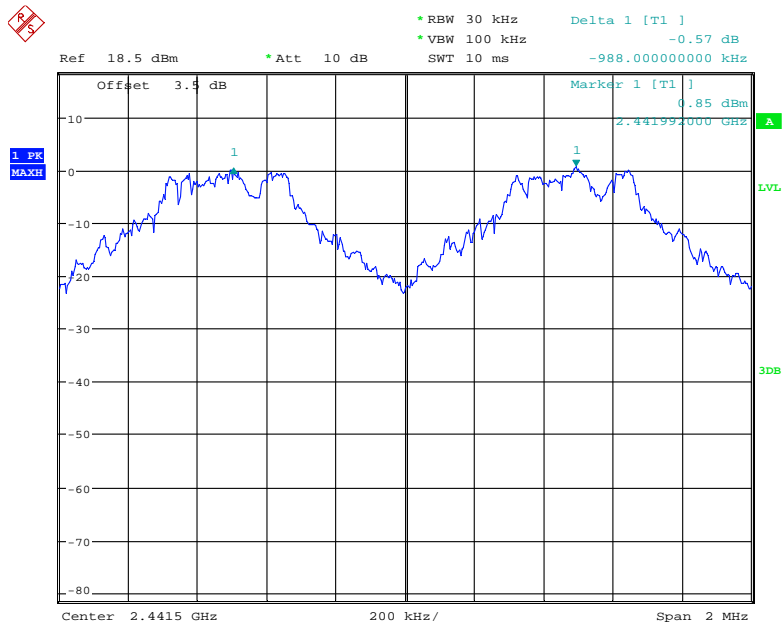

Date: 19.JUN.2019 15:24:25

BDR (GFSK): High Channel

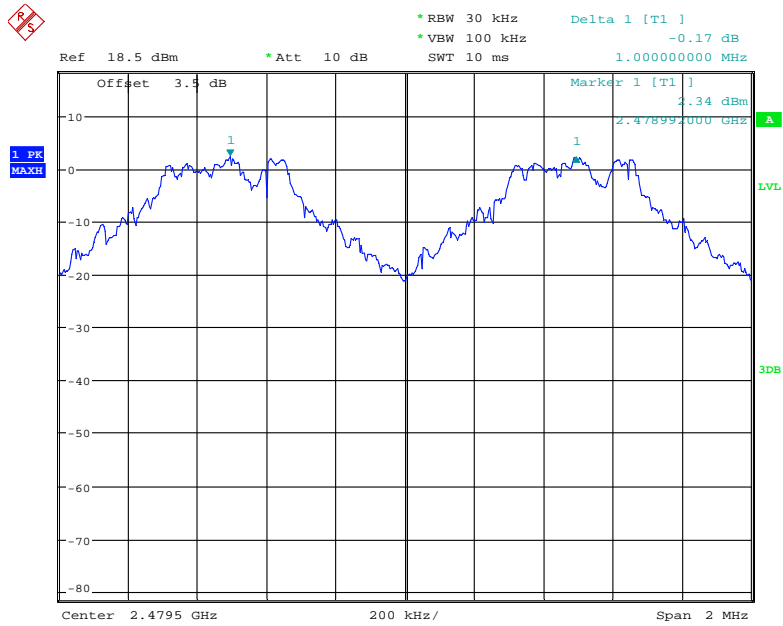

Date: 19.JUN.2019 15:19:46

EDR ($\pi/4$ -DQPSK): Low Channel

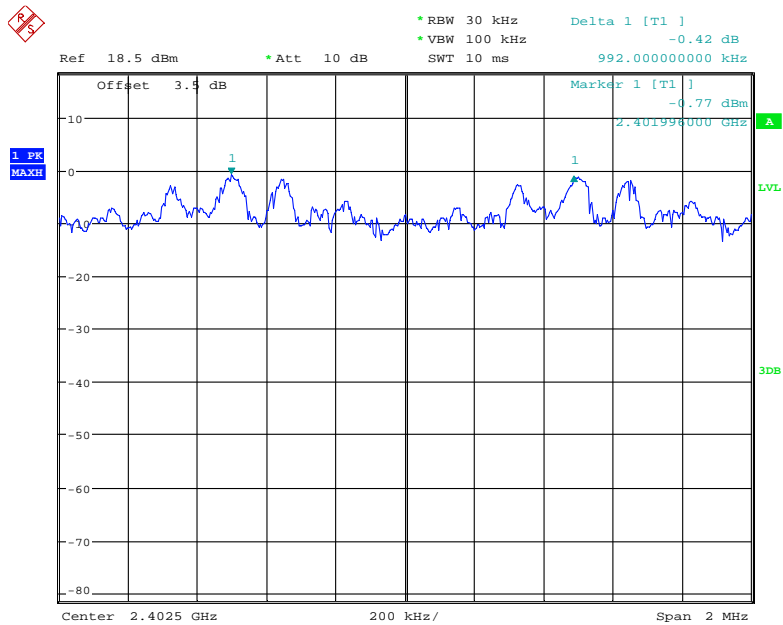

Date: 19.JUN.2019 15:30:02

EDR ($\pi/4$ -DQPSK): Middle Channel

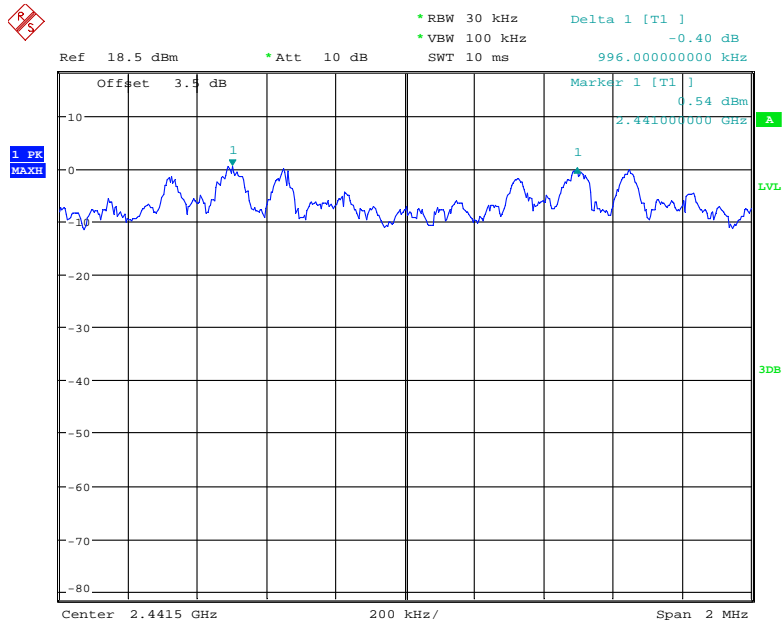

Date: 19.JUN.2019 15:33:17

EDR ($\pi/4$ -DQPSK): High Channel

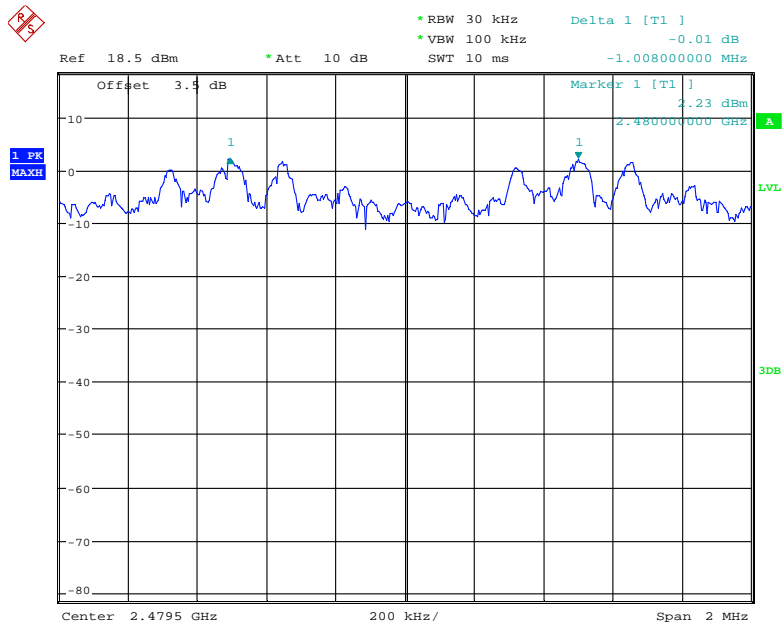

Date: 19.JUN.2019 15:36:15

EDR (8DPSK): Low Channel

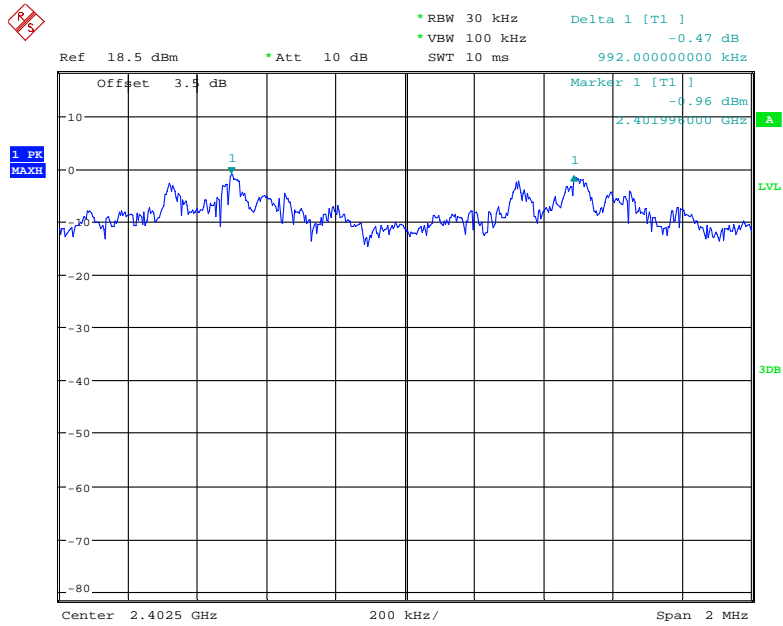

Date: 19.JUN.2019 15:45:45

EDR (8DPSK): Middle Channel

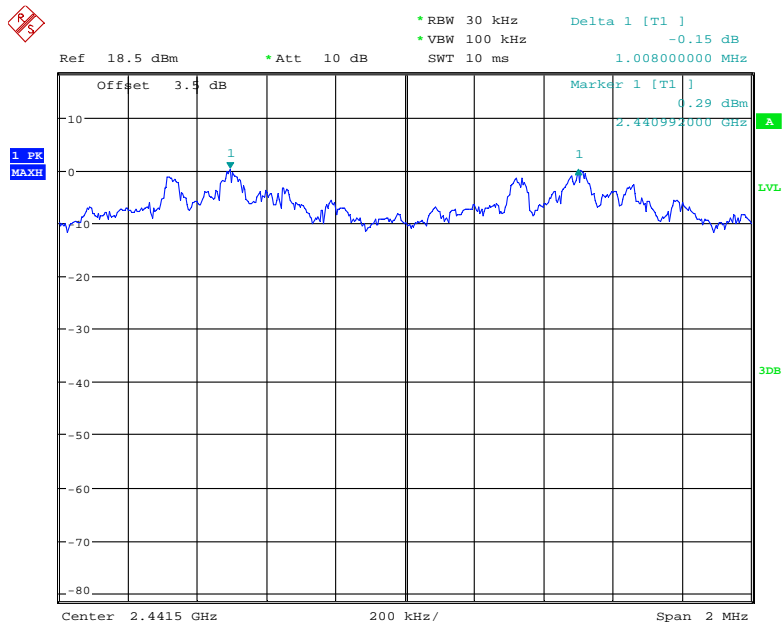

Date: 19.JUN.2019 15:42:14

EDR (8DPSK): High Channel

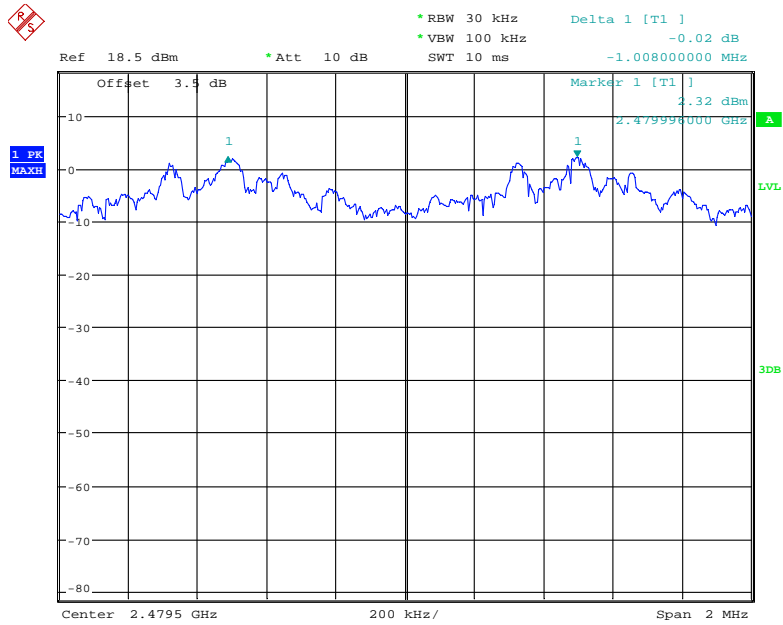

Date: 19.JUN.2019 15:39:20

FCC §15.247(a) (1) – 20 dB EMISSION BANDWIDTH

Applicable Standard

Alternatively, frequency hopping systems operating in the 2400–2483.5 MHz band may have hopping channel carrier frequencies that are separated by 25 kHz or two-thirds of the 20 dB bandwidth of the hopping channel, whichever is greater, provided the systems operate with an output power no greater than 125 mW.

Test Procedure

1. Check the calibration of the measuring instrument using either an internal calibrator or a known signal from an external generator.
2. Position the EUT without connection to measurement instrument. Turn on the EUT and connect it to measurement instrument. Then set it to any one convenient frequency within its operating range. Set a reference level on the measuring instrument equal to the highest peak value.
3. Measure the frequency difference of two frequencies that were attenuated 20 dB from the reference level. Record the frequency difference as the emission bandwidth.
4. Repeat above procedures until all frequencies measured were complete.

Test Data

Environmental Conditions

Temperature:	25 °C
Relative Humidity:	56 %
ATM Pressure:	101.0 kPa

The testing was performed by Leo Huang on 2019-06-19.

EUT operation mode: Transmitting

Test Result: Compliance. Please refer to following table and plots.

Mode	Channel	Frequency (MHz)	20 dB Emission Bandwidth (MHz)
BDR (GFSK)	Low	2402	0.929
	Middle	2441	0.927
	High	2480	0.934
EDR ($\pi/4$-DQPSK)	Low	2402	1.450
	Middle	2441	1.455
	High	2480	1.455
EDR (8DPSK)	Low	2402	1.458
	Middle	2441	1.455
	High	2480	1.460

BDR (GFSK): Low Channel

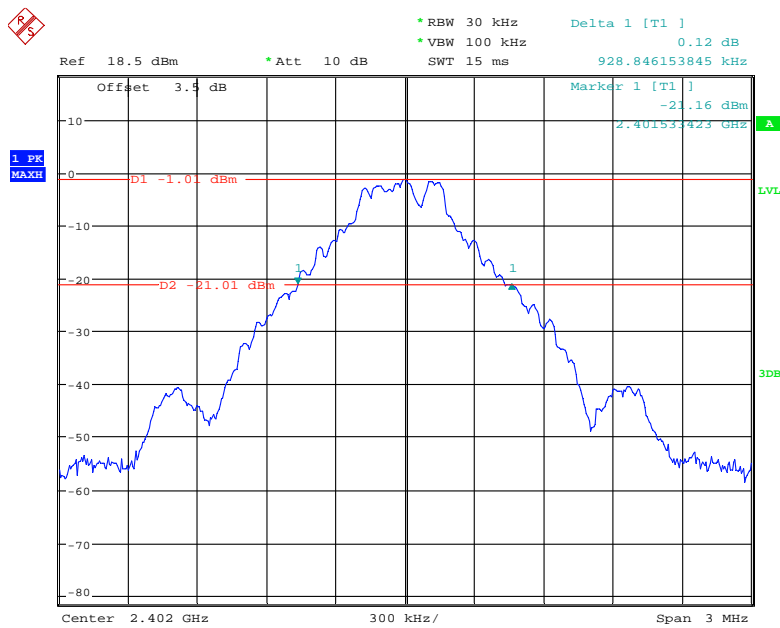

Date: 19.JUN.2019 16:39:27

BDR (GFSK): Middle Channel

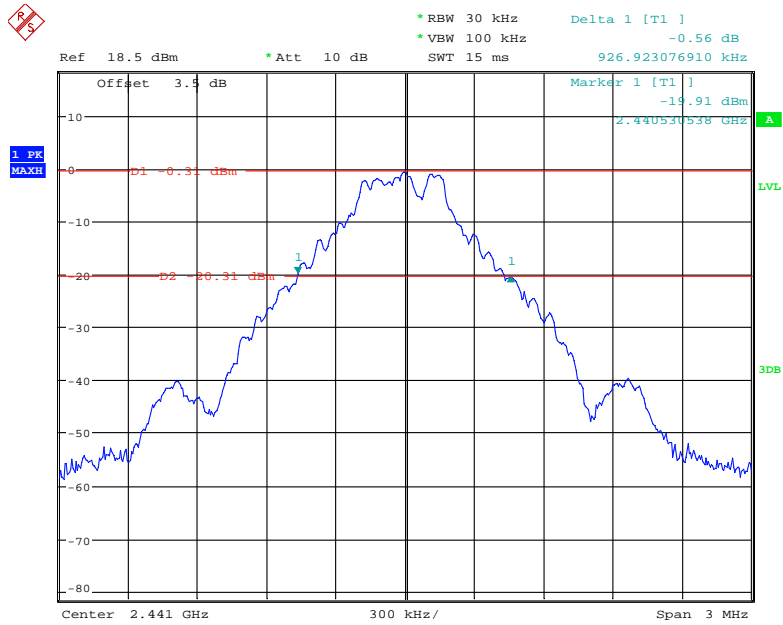

Date: 19.JUN.2019 16:40:48

BDR (GFSK): High Channel

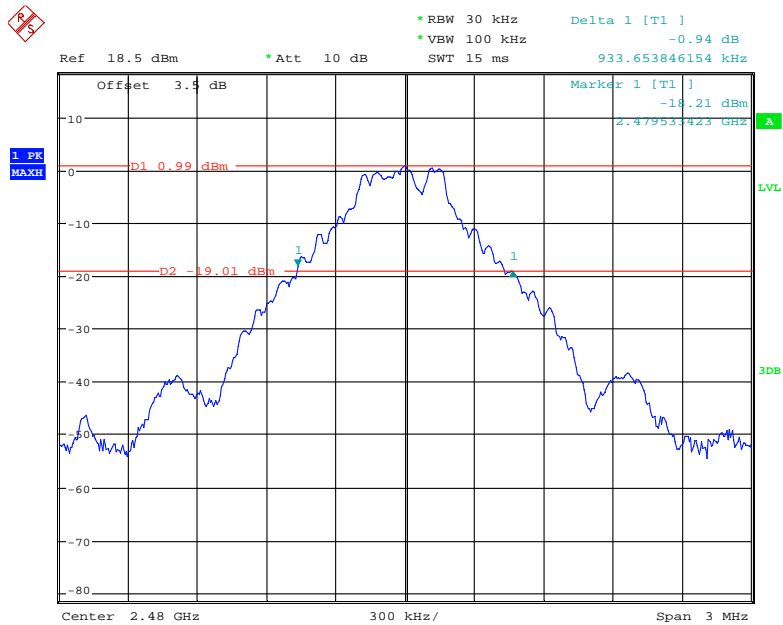

Date: 19.JUN.2019 16:42:23

EDR ($\pi/4$ -DQPSK): Low Channel

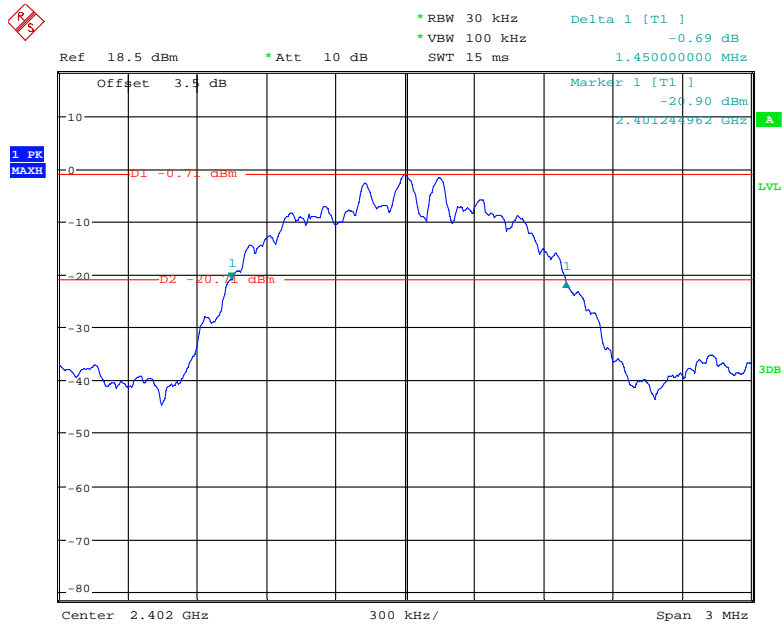

Date: 19.JUN.2019 16:37:40

EDR ($\pi/4$ -DQPSK): Middle Channel

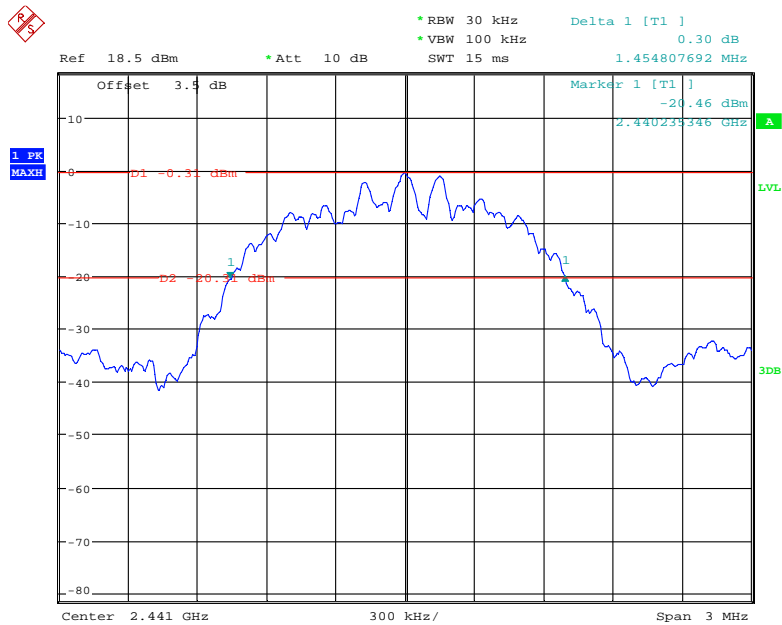

Date: 19.JUN.2019 16:36:13

EDR ($\pi/4$ -DQPSK): High Channel

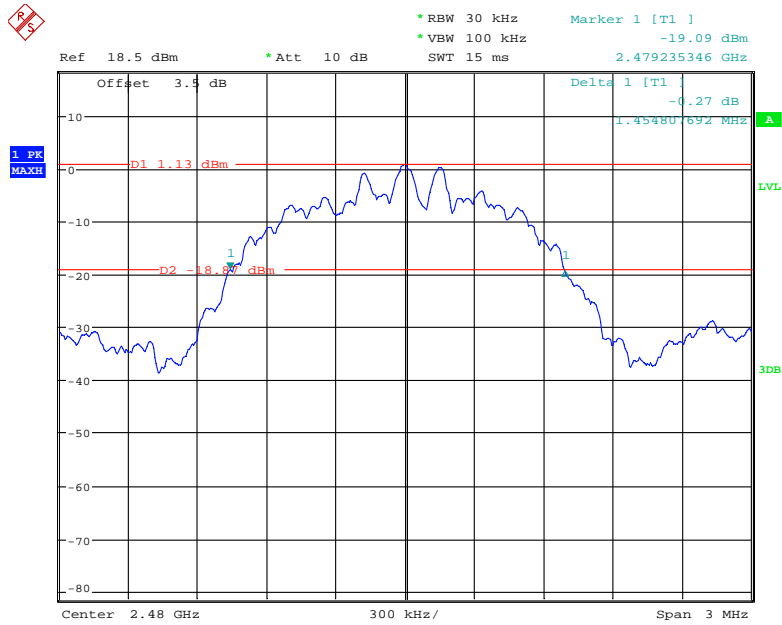

Date: 19.JUN.2019 16:33:52

EDR (8DPSK): Low Channel

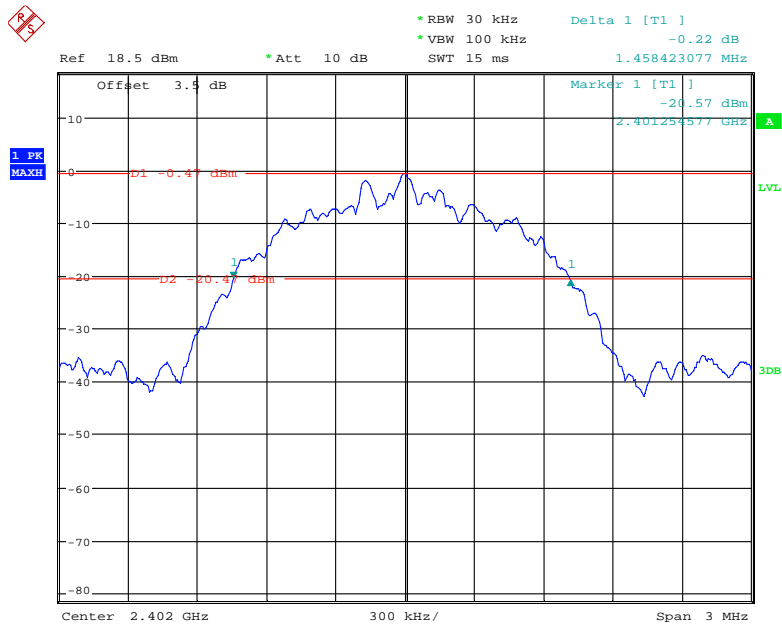

Date: 19.JUN.2019 16:27:15

EDR (8DPSK): Middle Channel

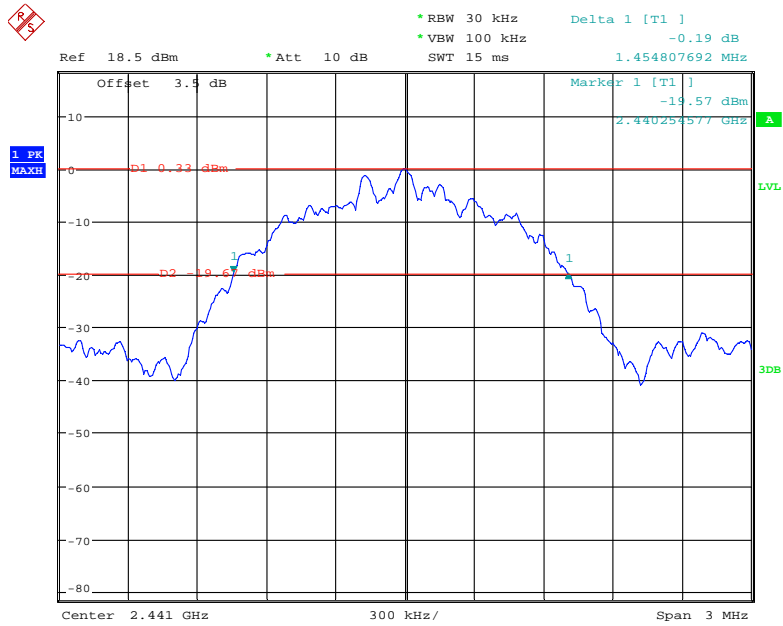

Date: 19.JUN.2019 16:29:18

EDR (8DPSK): High Channel

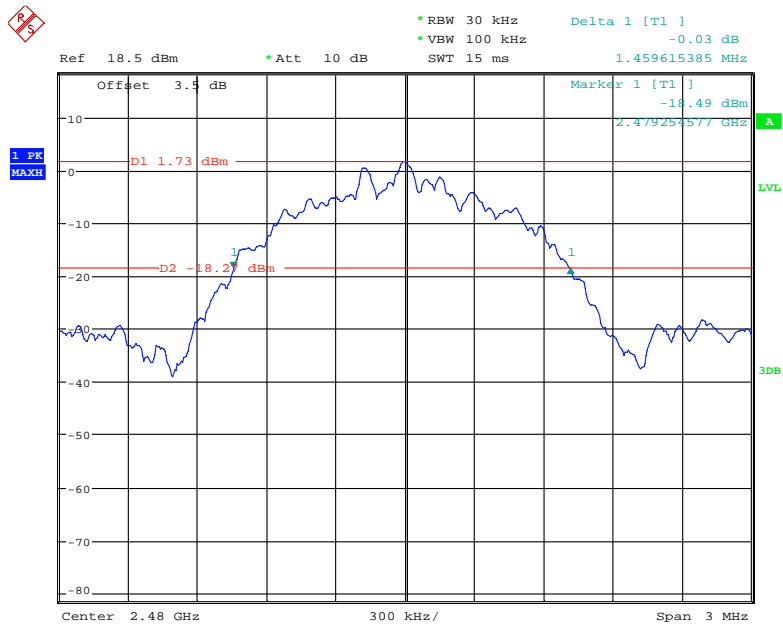

Date: 19.JUN.2019 16:31:35

FCC §15.247(a) (1) (iii)-QUANTITY OF HOPPING CHANNEL TEST

Applicable Standard

Frequency hopping systems in the 2400–2483.5 MHz band shall use at least 15 channels. The average time of occupancy on any channel shall not be greater than 0.4 seconds within a period of 0.4 seconds multiplied by the number of hopping channels employed. Frequency hopping systems may avoid or suppress transmissions on a particular hopping frequency provided that a minimum of 15 channels are used.

Test Procedure

1. Check the calibration of the measuring instrument (SA) using either an internal calibrator or a known signal from an external generator.
2. Set the EUT in hopping mode from first channel to last.
3. By using the max-hold function record the quantity of the channel.

Test Data

Environmental Conditions

Temperature:	25 °C
Relative Humidity:	56 %
ATM Pressure:	101.0 kPa

The testing was performed by Leo Huang on 2019-06-19.

EUT operation mode: Transmitting

Test Result: Compliance. Please refer to following table and plots.

Mode	Frequency Range (MHz)	Number of Hopping Channel (CH)	Limit (CH)
BDR (GFSK)	2400-2483.5	79	≥15
EDR (π/4-DQPSK)	2400-2483.5	79	≥15
EDR (8DPSK)	2400-2483.5	79	≥15

BDR (GFSK): Number of Hopping Channels

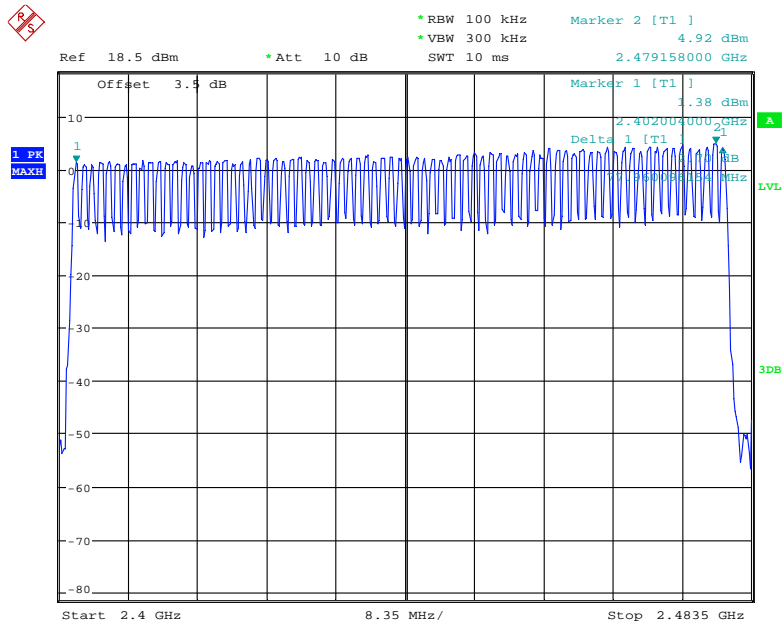

Date: 19.JUN.2019 15:55:51

EDR ($\pi/4$ -DQPSK): Number of Hopping Channels

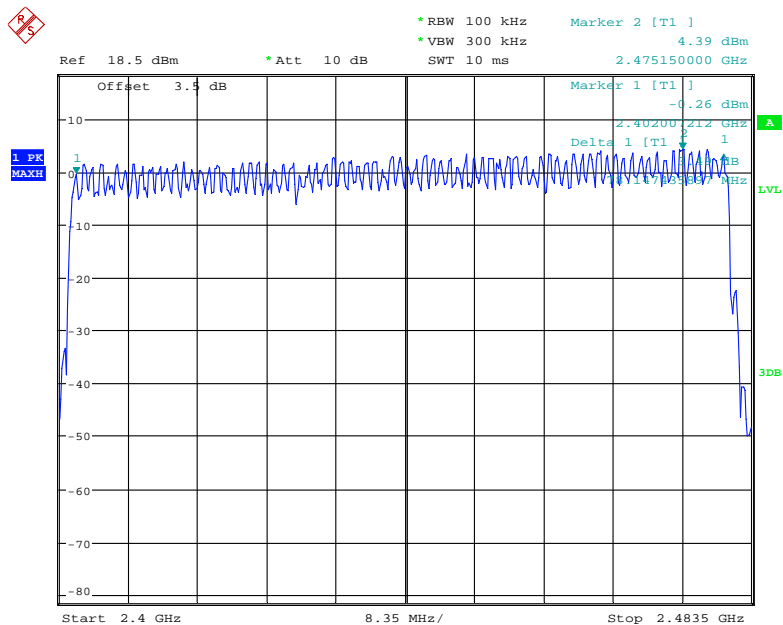

Date: 19.JUN.2019 15:58:13

EDR (8DPSK): Number of Hopping Channels

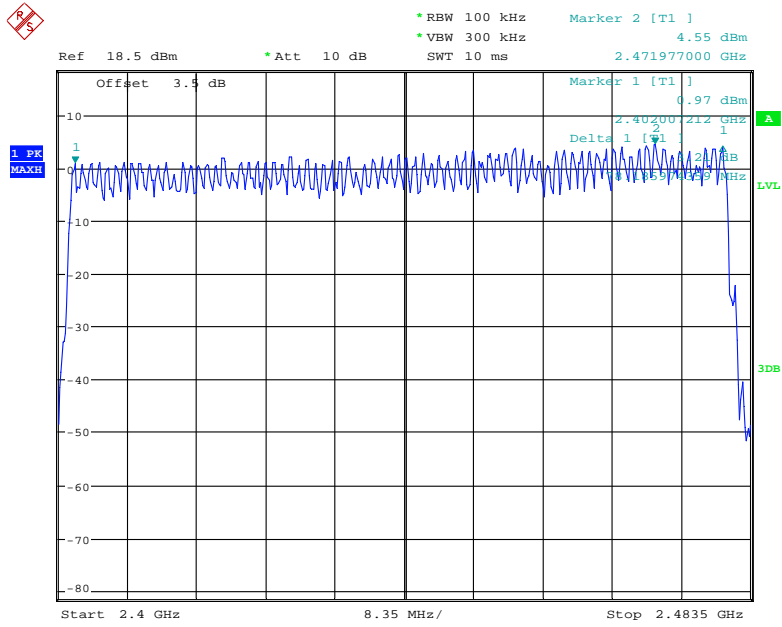

Date: 19.JUN.2019 16:00:11

FCC §15.247(a) (1) (iii) - TIME OF OCCUPANCY (DWELL TIME)

Applicable Standard

Frequency hopping systems in the 2400-2483.5 MHz shall use at least 15 channels. The average time of occupancy on any channel shall not be greater than 0.4 seconds within a period of 0.4 seconds multiplied by the number of hopping channels employed. Frequency hopping systems may avoid or suppress transmissions on a particular hopping frequency provided that a minimum of 15 channels are used.

Test Procedure

1. The EUT was worked in channel hopping.
2. Set the RBW to: 1MHz.
3. Set the VBW $\geq 3 \times$ RBW.
4. Set the span to 0Hz.
5. Detector = peak.
6. Sweep time = auto couple.
7. Trace mode = max hold.
8. Allow trace to fully stabilize.
9. Recorded the time of single pulses

Test Data

Environmental Conditions

Temperature:	25~27 °C
Relative Humidity:	56~58 %
ATM Pressure:	100.0~101.0 kPa

The testing was performed by Leo Huang on 2019-06-20 and 2019-07-05.

EUT operation mode: Transmitting

Test Result: Compliance. Please refer to following table and plots

Mode		Channel	Pulse Width (ms)	Dwell Time (S)	Limit (S)	Result
BDR (GFSK)	DH 1	Low	0.459	0.147	0.4	Pass
		Middle	0.459	0.147	0.4	Pass
		High	0.459	0.147	0.4	Pass
		Note: DH1:Dwell time = Pulse time*(1600/2/79)*31.6S				
	DH 3	Low	1.737	0.278	0.4	Pass
		Middle	1.737	0.278	0.4	Pass
		High	1.737	0.278	0.4	Pass
		Note: DH3:Dwell time = Pulse time*(1600/4/79)*31.6S				
	DH 5	Low	2.985	0.318	0.4	Pass
		Middle	2.985	0.318	0.4	Pass
		High	2.985	0.318	0.4	Pass
		Note: DH5:Dwell time = Pulse time*(1600/6/79)*31.6S				
	EDR (π/4-DQPSK)	2DH 1	Low	0.467	0.149	0.4
Middle			0.467	0.149	0.4	Pass
High			0.467	0.149	0.4	Pass
Note: 2DH1:Dwell time = Pulse time*(1600/2/79)*31.6S						
2DH 3		Low	1.737	0.278	0.4	Pass
		Middle	1.737	0.278	0.4	Pass
		High	1.737	0.278	0.4	Pass
		Note: 2DH3:Dwell time = Pulse time*(1600/4/79)*31.6S				
2DH 5		Low	2.985	0.318	0.4	Pass
		Middle	2.985	0.318	0.4	Pass
		High	2.985	0.318	0.4	Pass
		Note:2DH5:Dwell time = Pulse time*(1600/6/79)*31.6S				
EDR (8DPSK)		3DH 1	Low	0.467	0.149	0.4
	Middle		0.467	0.149	0.4	Pass
	High		0.467	0.149	0.4	Pass
	Note: 3DH1:Dwell time = Pulse time*(1600/2/79)*31.6S					
	3DH 3	Low	1.737	0.278	0.4	Pass
		Middle	1.737	0.278	0.4	Pass
		High	1.737	0.278	0.4	Pass
		Note: 3DH3:Dwell time = Pulse time*(1600/4/79)*31.6S				
	3DH 5	Low	3.001	0.320	0.4	Pass
		Middle	3.001	0.320	0.4	Pass
		High	3.001	0.320	0.4	Pass
		Note: 3DH5:Dwell time = Pulse time*(1600/6/79)*31.6S				

BDR (GFSK): Pulse time, Low Channel, DH1

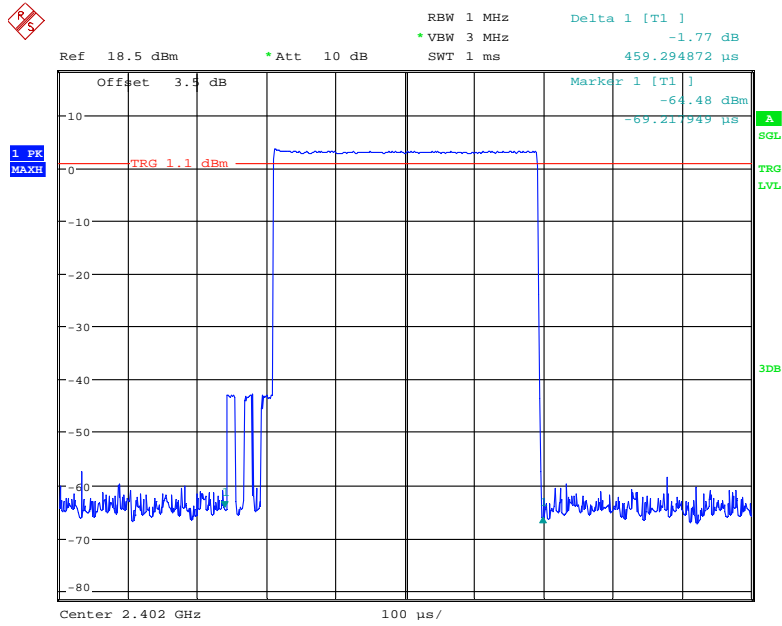

Date: 20.JUN.2019 10:15:49

Pulse time, Middle Channel, DH1

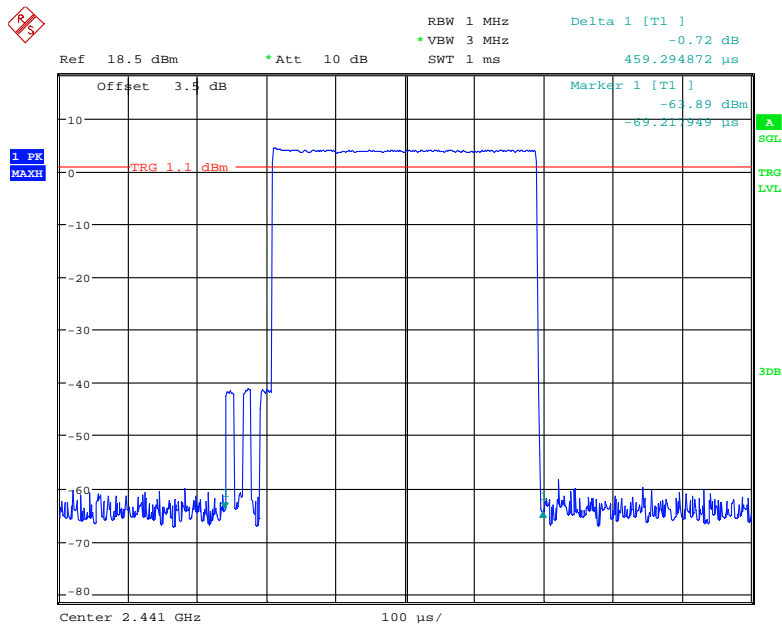

Date: 20.JUN.2019 10:15:26

Pulse time, High Channel, DH1

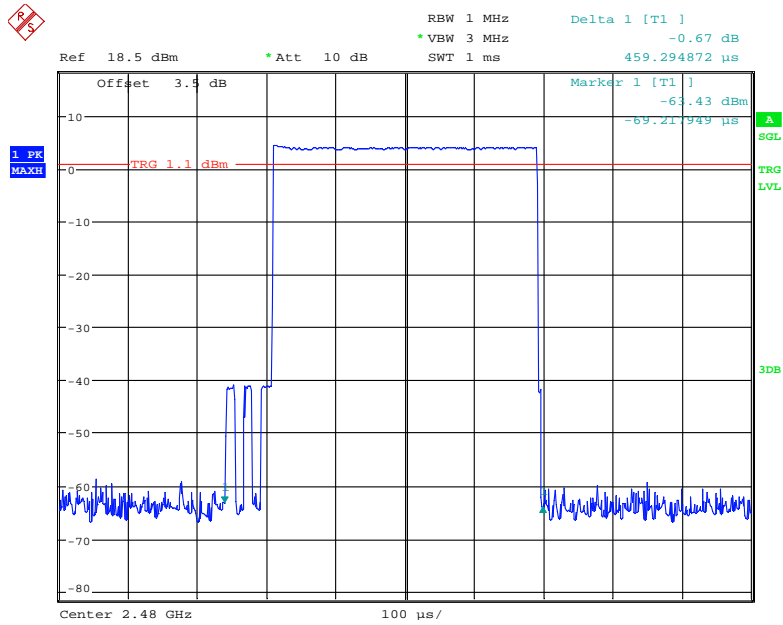

Date: 20.JUN.2019 10:14:44

Pulse time, Low Channel, DH3

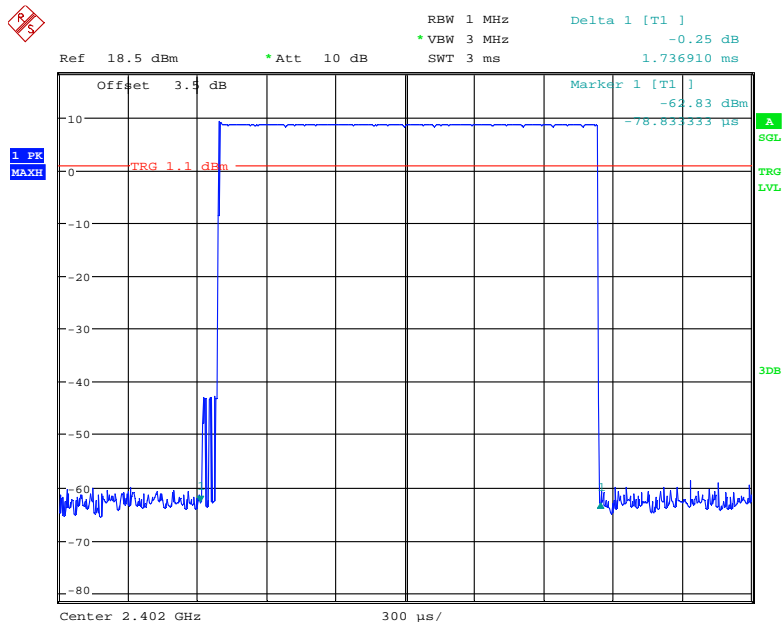

Date: 20.JUN.2019 10:41:38

Pulse time, Middle Channel, DH3

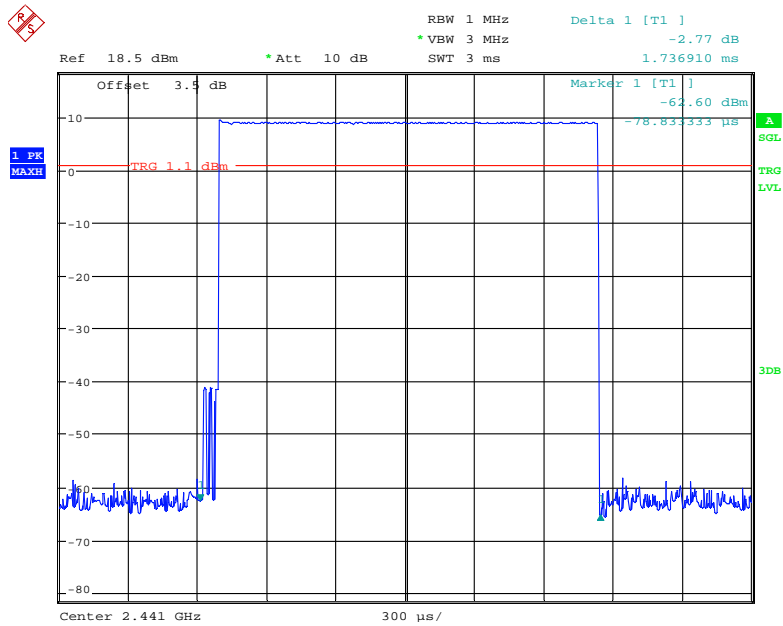

Date: 20.JUN.2019 10:43:11

Pulse time, High Channel, DH3

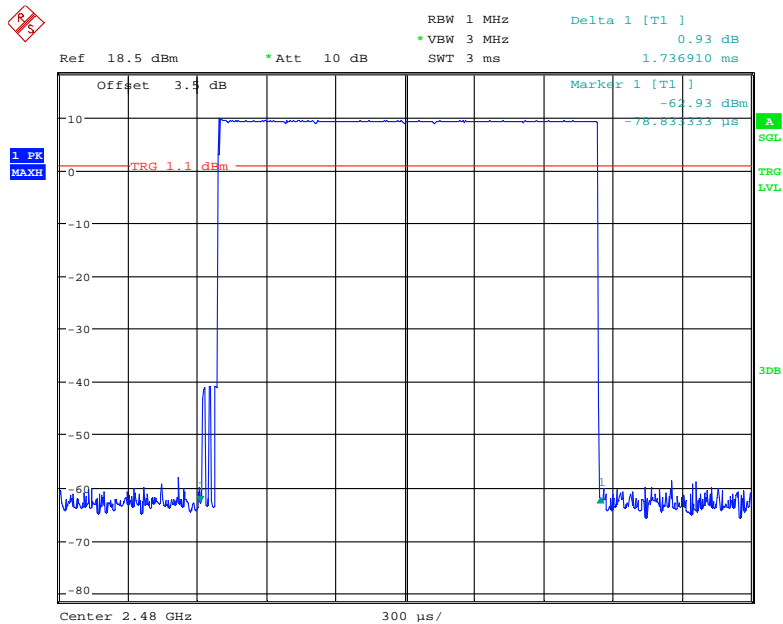

Date: 20.JUN.2019 10:43:50

Pulse time, Low Channel, DH5

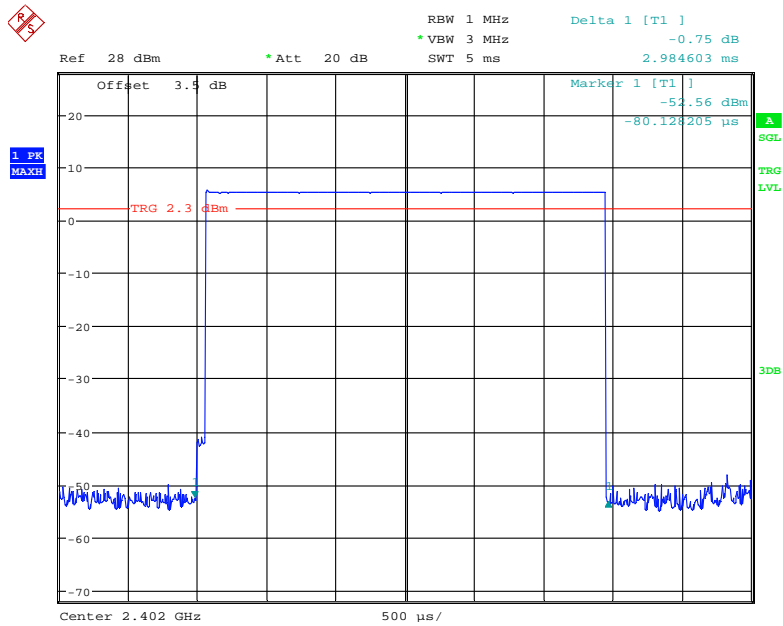

Date: 5.JUL.2019 14:32:23

Pulse time, Middle Channel, DH5

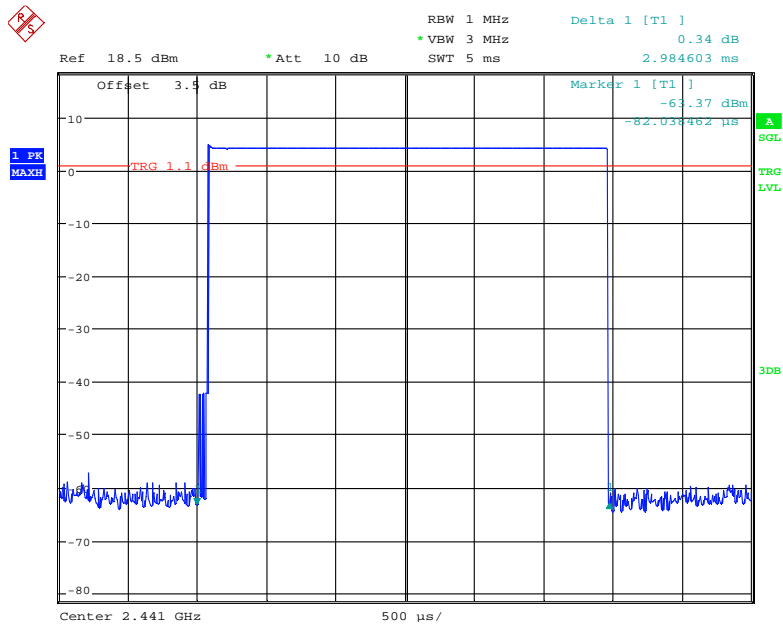

Date: 20.JUN.2019 10:52:41

Pulse time, High Channel, DH5

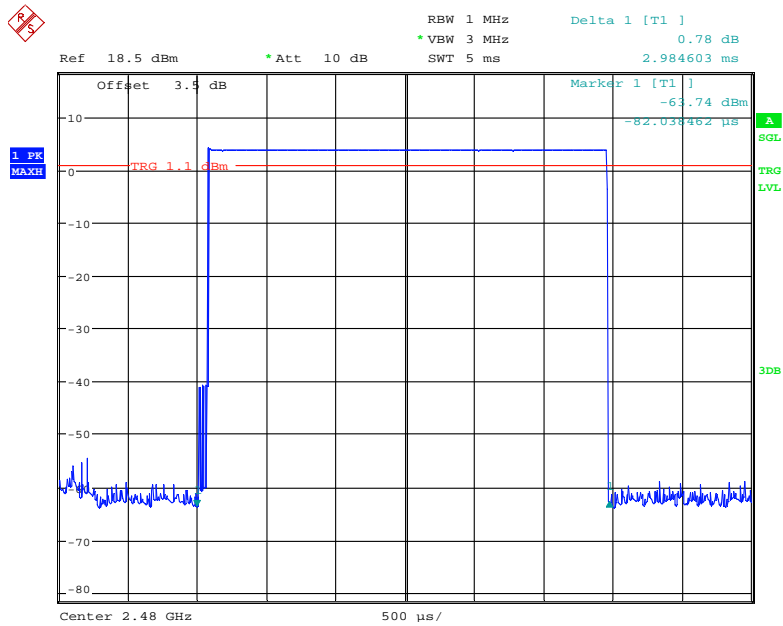

Date: 20.JUN.2019 10:53:00

EDR ($\pi/4$ -DQPSK):

Pulse time, Low Channel, 2DH1

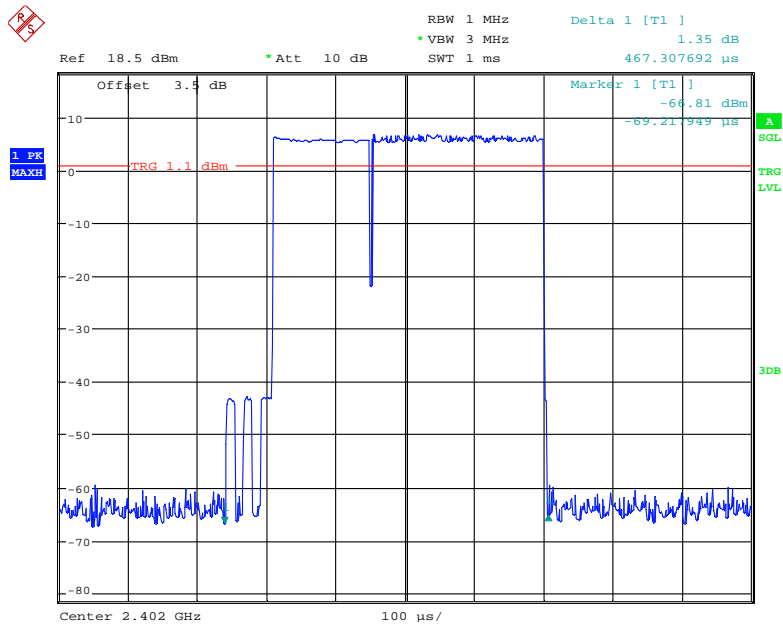

Date: 20.JUN.2019 10:16:56

Pulse time, Middle Channel, 2DH1

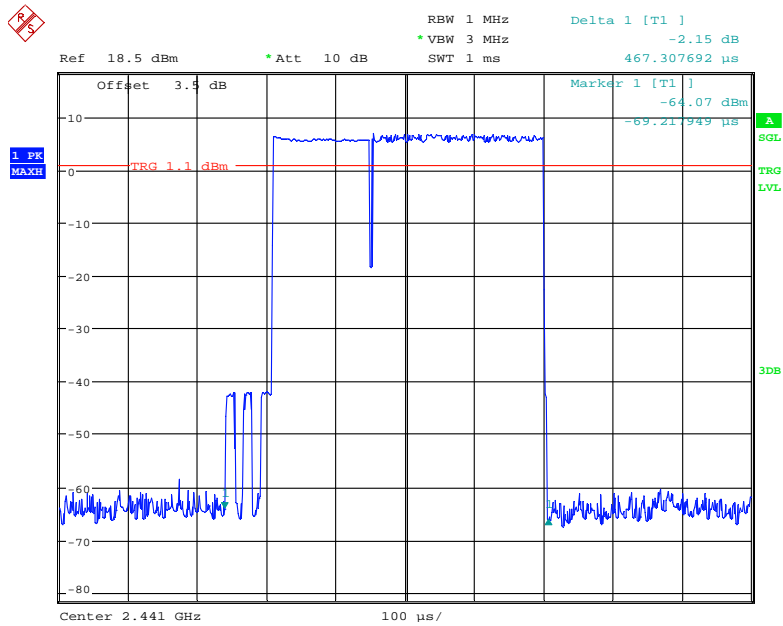

Date: 20.JUN.2019 10:17:18

Pulse time, High Channel, 2DH1

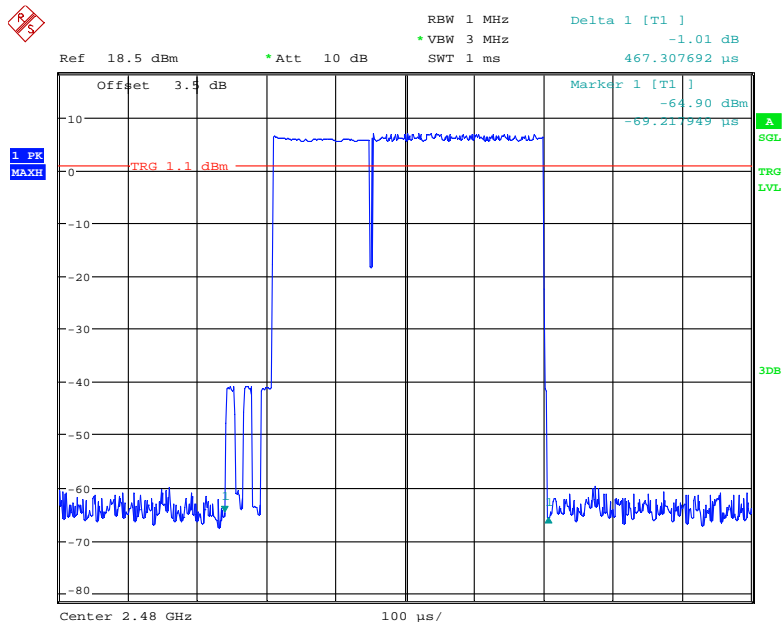

Date: 20.JUN.2019 10:36:16

Pulse time, Low Channel, 2DH3

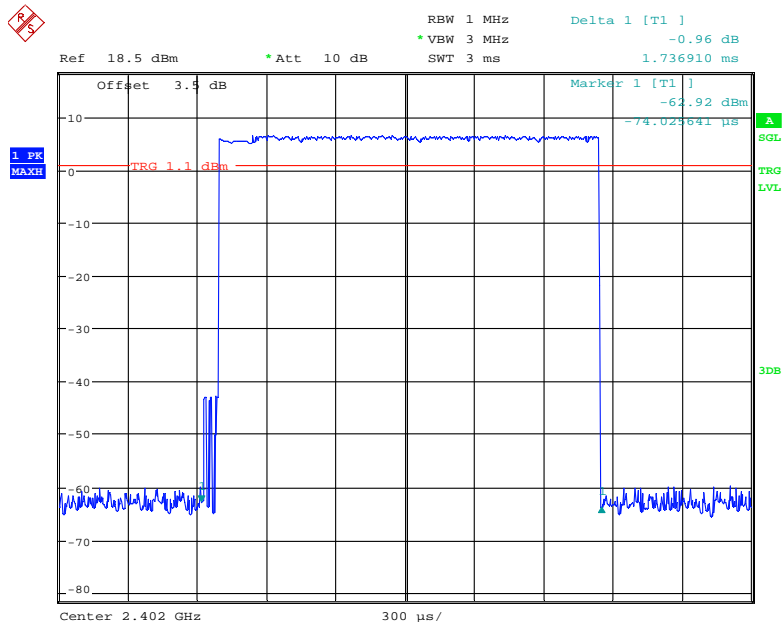

Date: 20.JUN.2019 10:47:42

Pulse time, Middle Channel, 2DH3

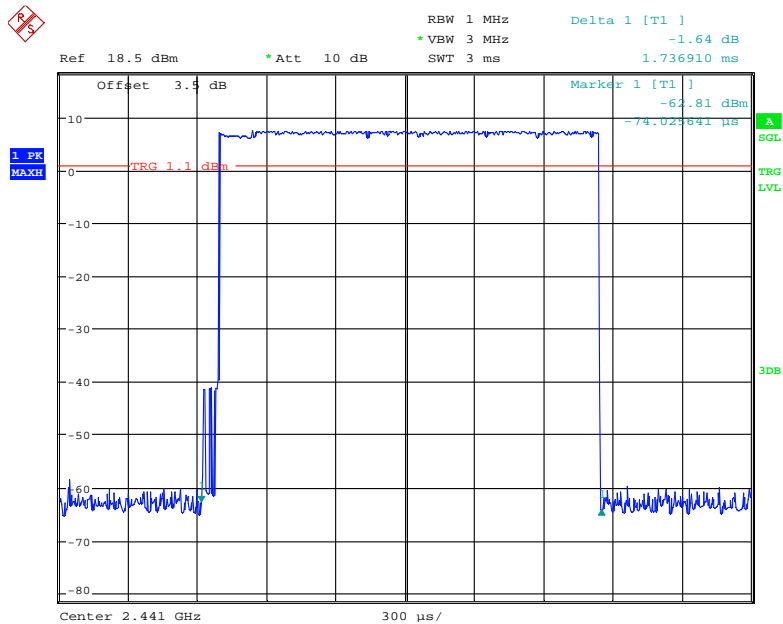

Date: 20.JUN.2019 10:47:14

Pulse time, High Channel, 2DH3

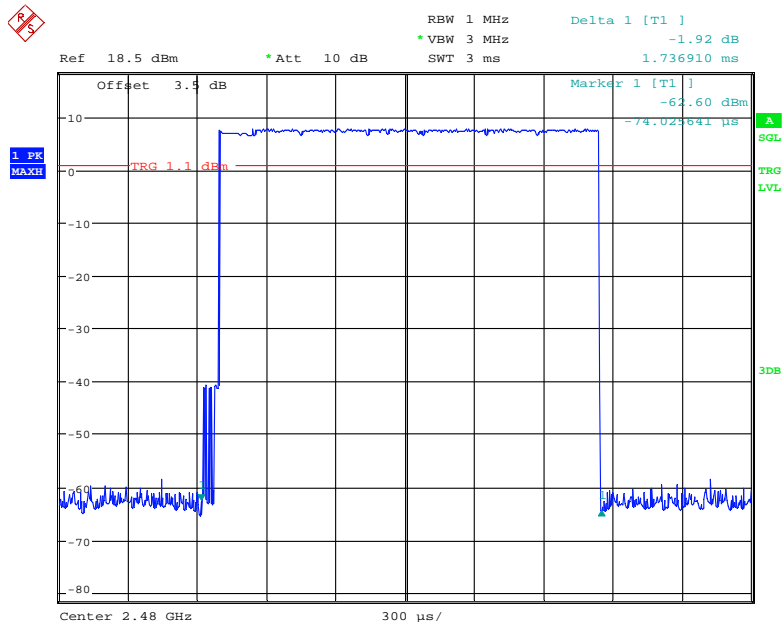

Date: 20.JUN.2019 10:46:42

Pulse time, Low Channel, 2DH5

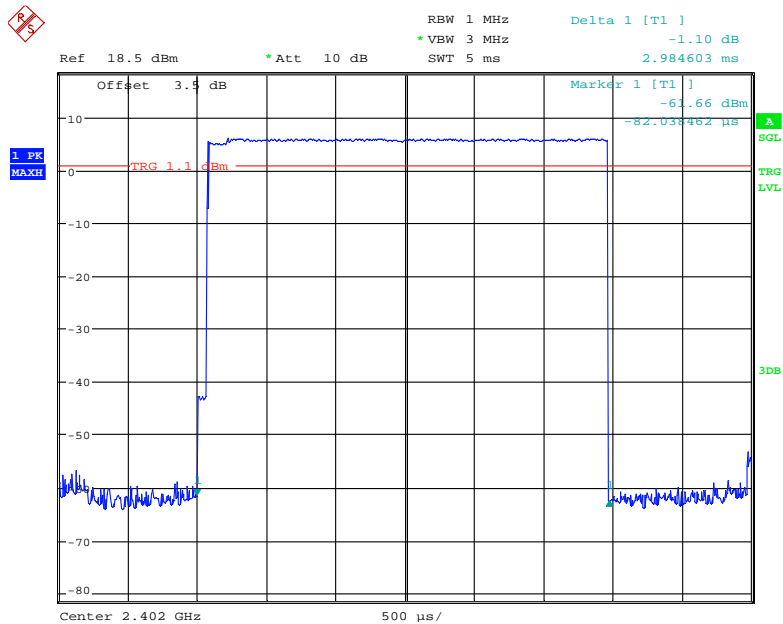

Date: 20.JUN.2019 10:54:44

Pulse time, Middle Channel, 2DH5

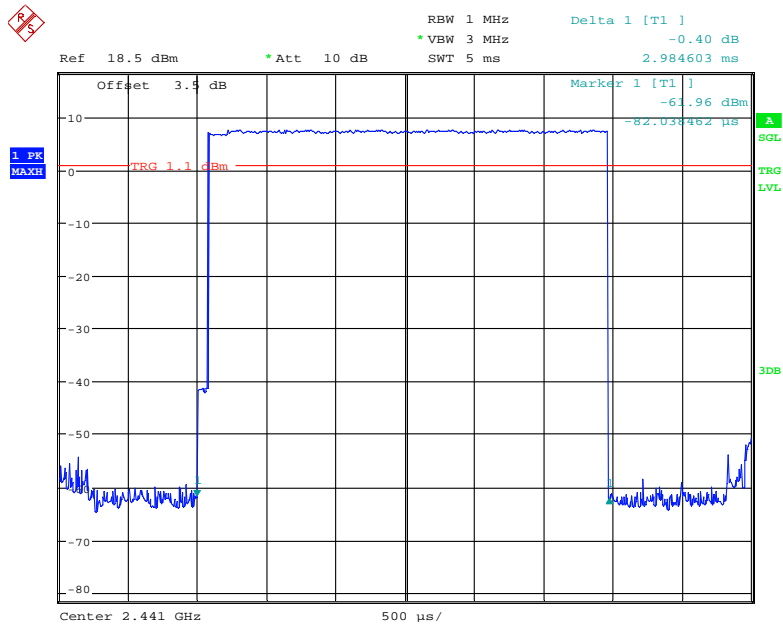

Date: 20.JUN.2019 10:54:27

Pulse time, High Channel, 2DH5

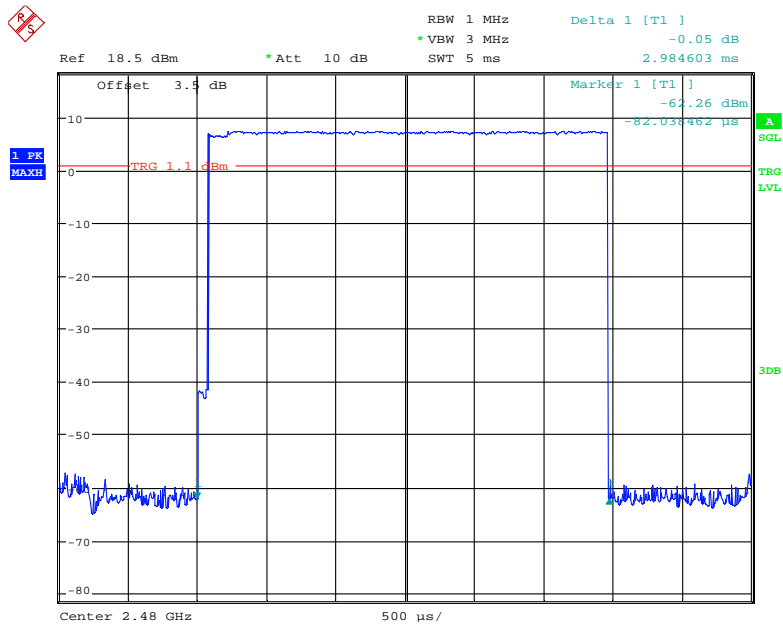

Date: 20.JUN.2019 10:53:54

EDR (8DPSK): Pulse time, Low Channel, 3DH1

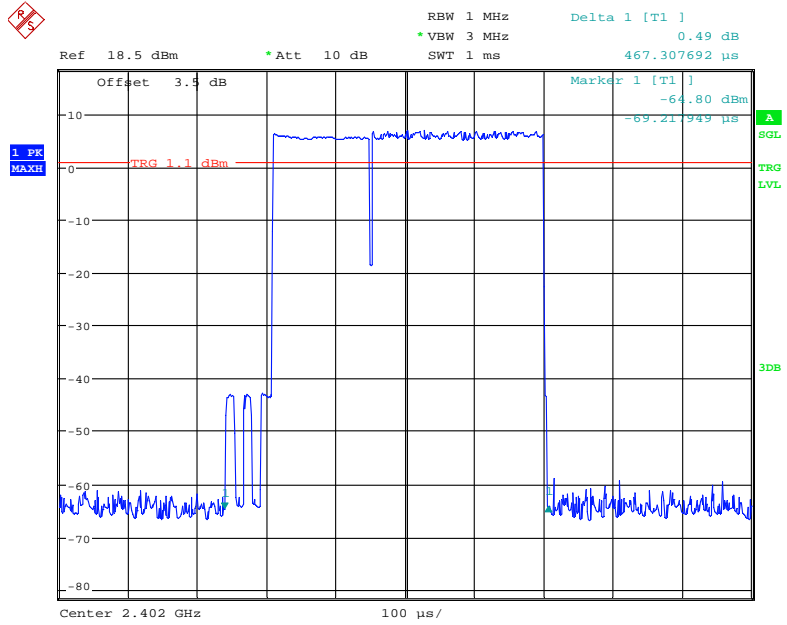

Date: 20.JUN.2019 10:38:41

Pulse time, Middle Channel, 3DH1

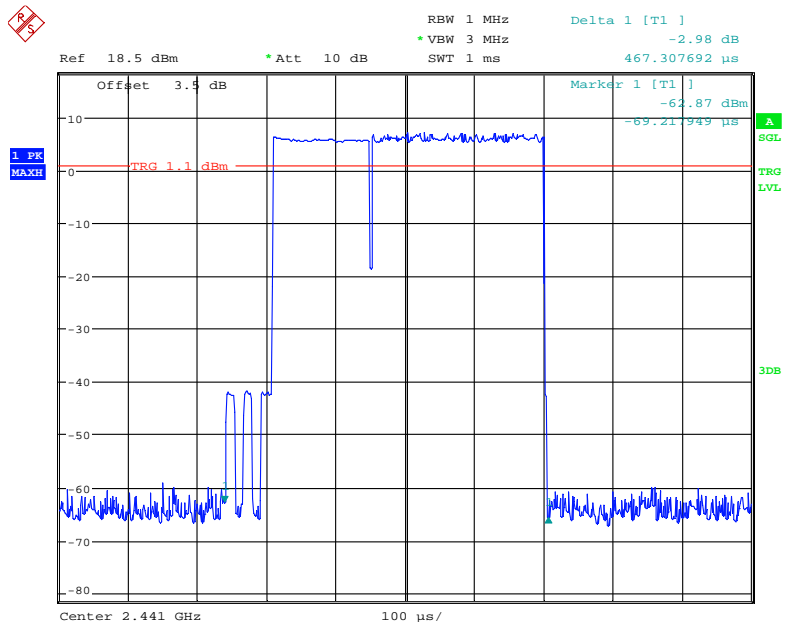

Date: 20.JUN.2019 10:38:20

Pulse time, High Channel, 3DH1

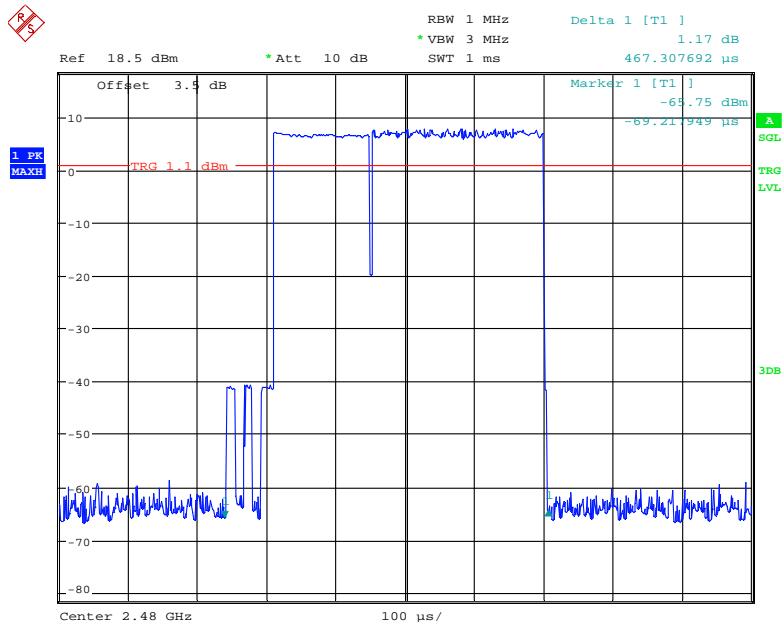

Date: 20.JUN.2019 10:37:33

Pulse time, Low Channel, 3DH3

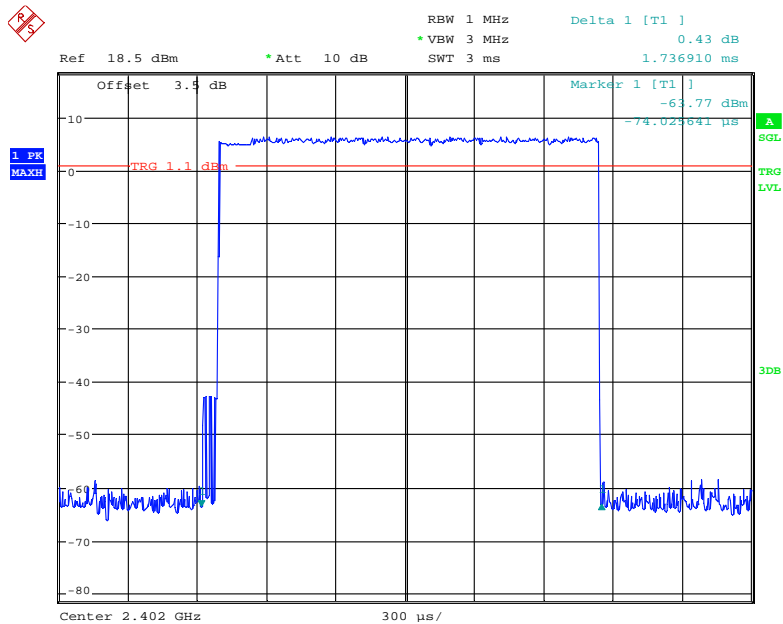

Date: 20.JUN.2019 10:49:06

Pulse time, Middle Channel, 3DH3

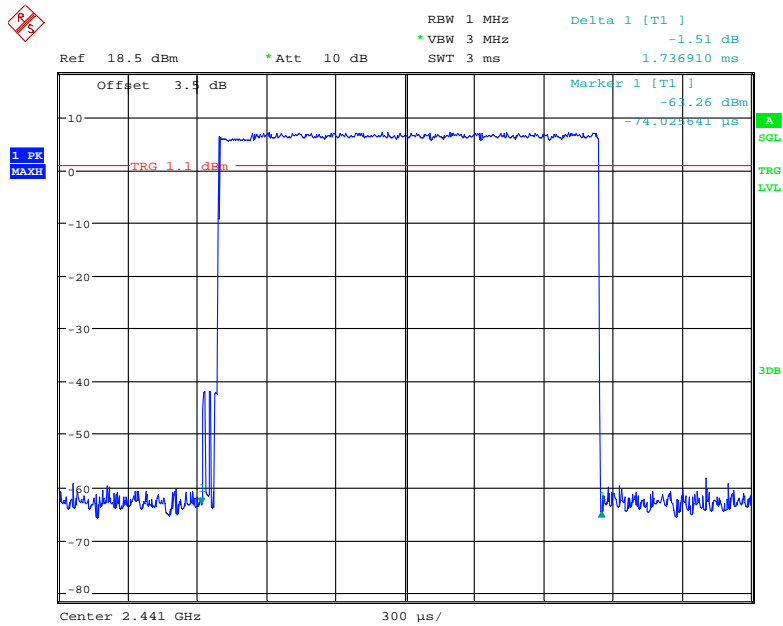

Date: 20.JUN.2019 10:49:52

Pulse time, High Channel, 3DH3

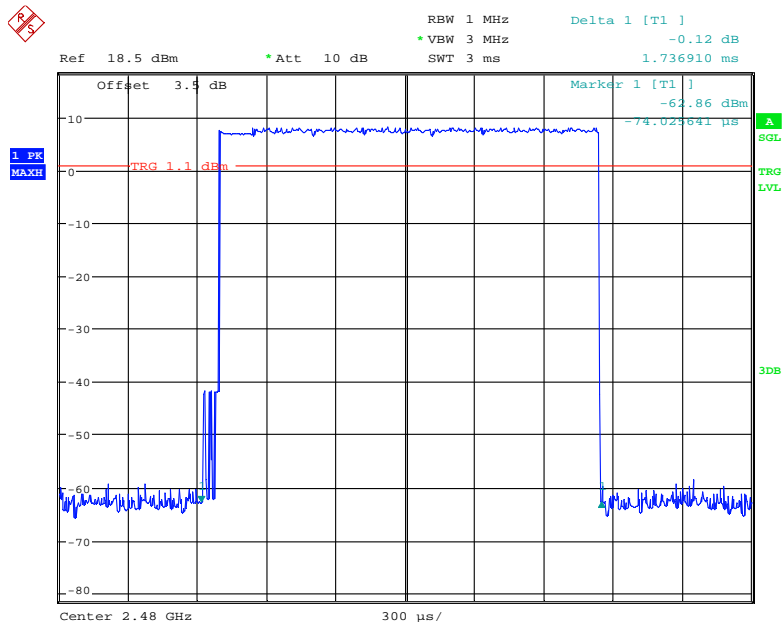

Date: 20.JUN.2019 10:50:08

Pulse time, Low Channel, 3DH5

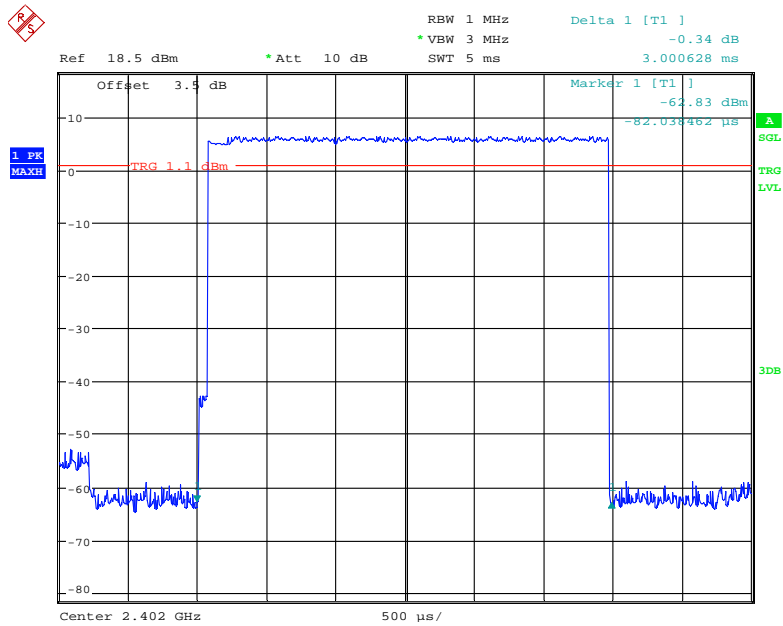

Date: 20.JUN.2019 10:57:18

Pulse time, Middle Channel, 3DH5

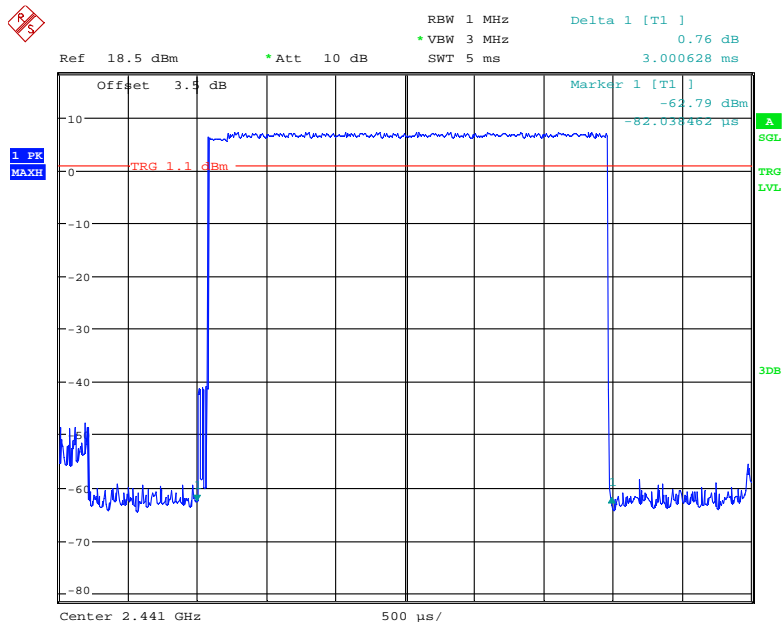

Date: 20.JUN.2019 10:57:54

Pulse time, High Channel, 3DH5

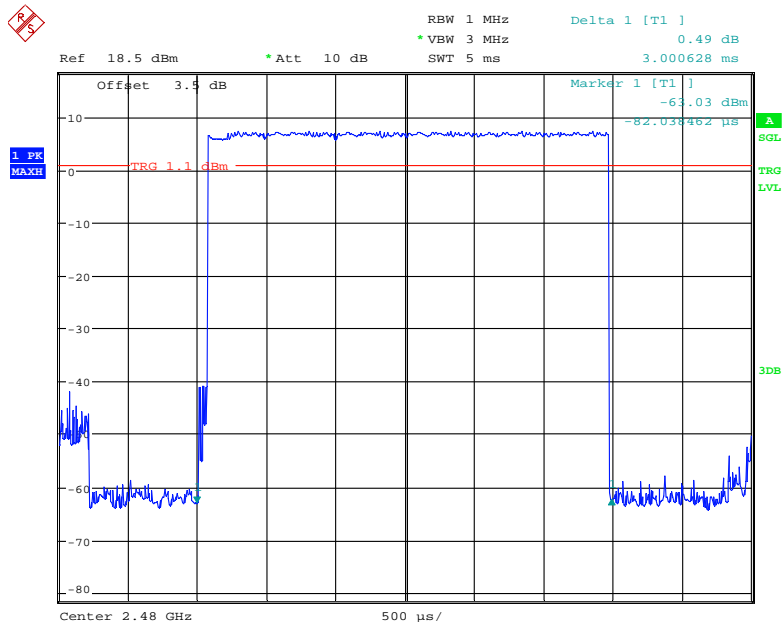

Date: 20.JUN.2019 10:58:16

FCC §15.247(b) (1) - PEAK OUTPUT POWER MEASUREMENT

Applicable Standard

According to §15.247(b) (1), for frequency hopping systems operating in the 2400–2483.5 MHz band employing at least 75 non-overlapping hopping channels, and all frequency hopping systems in the 5725–5850 MHz band: 1 watt. And for all other frequency hopping systems in the 2400–2483.5 MHz band: 0.125 watts.

Test Procedure

1. Place the EUT on a bench and set in transmitting mode.
2. Remove the antenna from the EUT and then connect a low loss RF cable from the antenna port to one test equipment.
3. Add a correction factor to the display.

Test Data

Environmental Conditions

Temperature:	25 °C
Relative Humidity:	56 %
ATM Pressure:	101.0 kPa

The testing was performed by Leo Huang on 2019-06-19.

EUT operation mode: Transmitting

Test Result: Compliance. Please refer to following table.

Mode	Channel	Frequency (MHz)	Peak Output Power		Limit (mW)
			(dBm)	(mW)	
BDR (GFSK)	Low	2402	2.82	1.91	125
	Middle	2441	3.18	2.08	125
	High	2480	4.56	2.86	125
	Max	2479	4.99	3.16	125
EDR ($\pi/4$-DQPSK)	Low	2402	4.23	2.65	125
	Middle	2441	4.40	2.75	125
	High	2480	5.37	3.44	125
	Max	2475	5.41	3.48	125
EDR (8DPSK)	Low	2402	4.37	2.74	125
	Middle	2441	4.47	2.80	125
	High	2480	5.40	3.47	125
	Max	2472	5.45	3.51	125

FCC §15.247(d) - BAND EDGES TESTING

Applicable Standard

In any 100 kHz bandwidth outside the frequency band in which the spread spectrum or digitally modulated intentional radiator is operating, the radio frequency power that is produced by the intentional radiator shall be at least 20 dB below that in the 100 kHz bandwidth within the band that contains the highest level of the desired power, based on either an RF conducted or a radiated measurement, provided the transmitter demonstrates compliance with the peak conducted power limits. If the transmitter complies with the conducted power limits based on the use of RMS averaging over a time interval, as permitted under paragraph (b)(3) of this section, the attenuation required under this paragraph shall be 30 dB instead of 20 dB. Attenuation below the general limits specified in §15.209(a) is not required. In addition, radiated emissions which fall in the restricted bands, as defined in §15.205(a), must also comply with the radiated emission limits specified in §15.209(a) (see §15.205(c)).

Test Procedure

1. Check the calibration of the measuring instrument using either an internal calibrator or a known signal from an external generator.
2. Remove the antenna from the EUT and then connect to a low loss RF cable from the antenna port to a EMI test receiver, then turn on the EUT and make it operate in transmitting mode. Then set it to Low Channel and High Channel within its operating range, and make sure the instrument is operated in its linear range.
3. Set RBW of spectrum analyzer to 100 kHz with a convenient frequency span including 100 kHz bandwidth from band edge.
4. Measure the highest amplitude appearing on spectral display and set it as a reference level. Plot the graph with marking the highest point and edge frequency.
5. Repeat above procedures until all measured frequencies were complete.

Test Data

Environmental Conditions

Temperature:	25 °C
Relative Humidity:	56 %
ATM Pressure:	101.0 kPa

The testing was performed by Leo Huang from 2019-06-19 to 2019-07-05.

EUT operation mode: Transmitting

Test Result: Compliance. Please refer to following plots.

BDR (GFSK): Band Edge-Left Side

Hopping

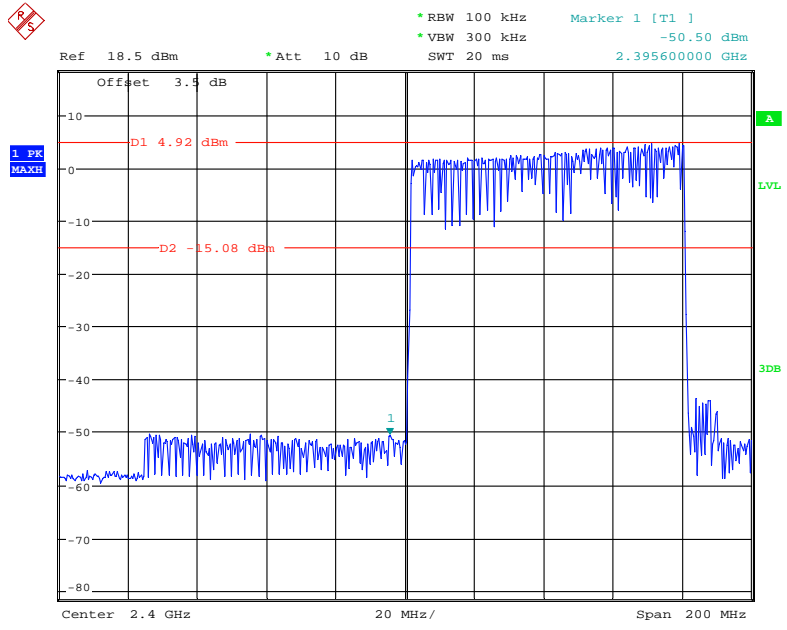

Date: 19.JUN.2019 16:14:12

Single

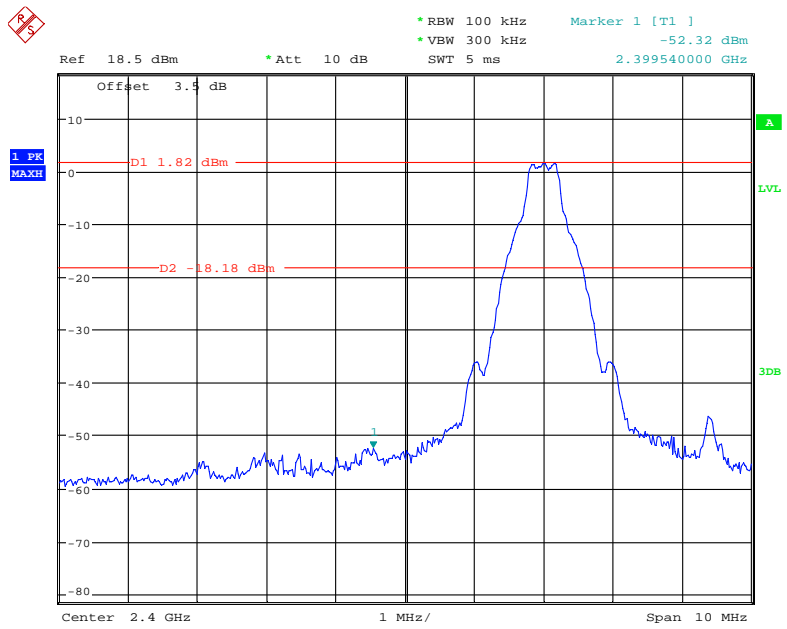

Date: 19.JUN.2019 16:20:12

BDR (GFSK): Band Edge-Right Side Hopping

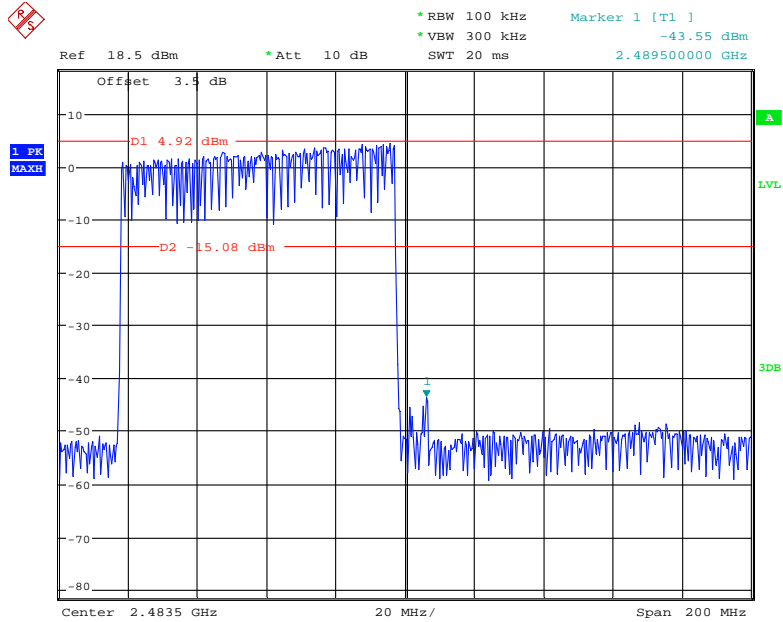

Date: 19.JUN.2019 16:16:18

Single

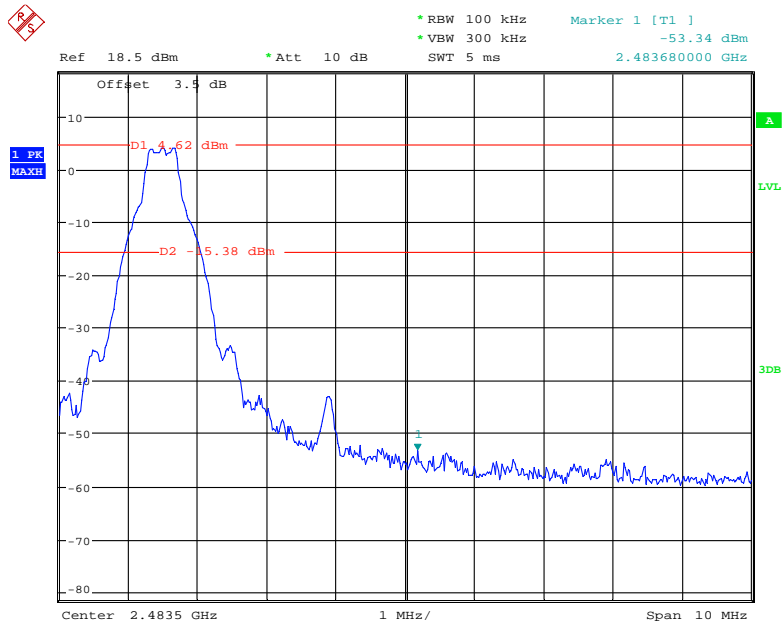

Date: 19.JUN.2019 16:17:48

EDR ($\pi/4$ -DQPSK): Band Edge-Left Side Hopping

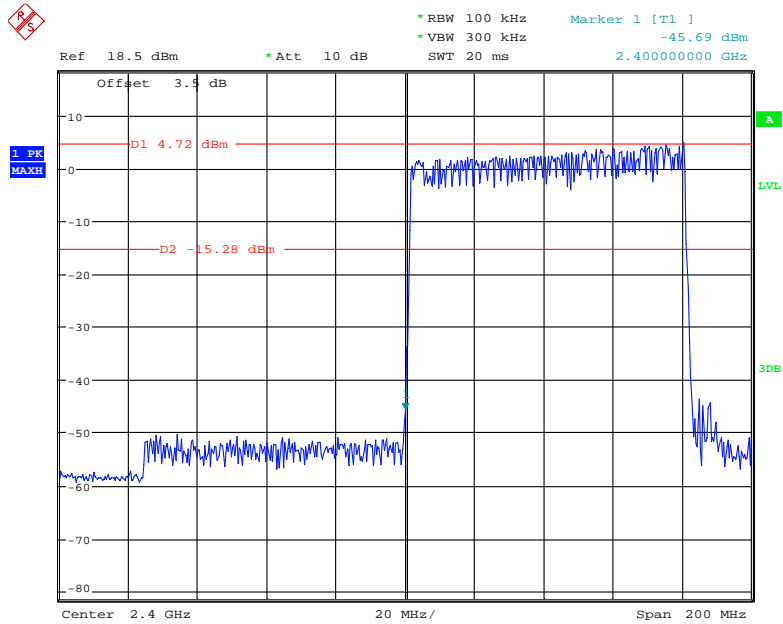

Date: 19.JUN.2019 16:11:03

Single

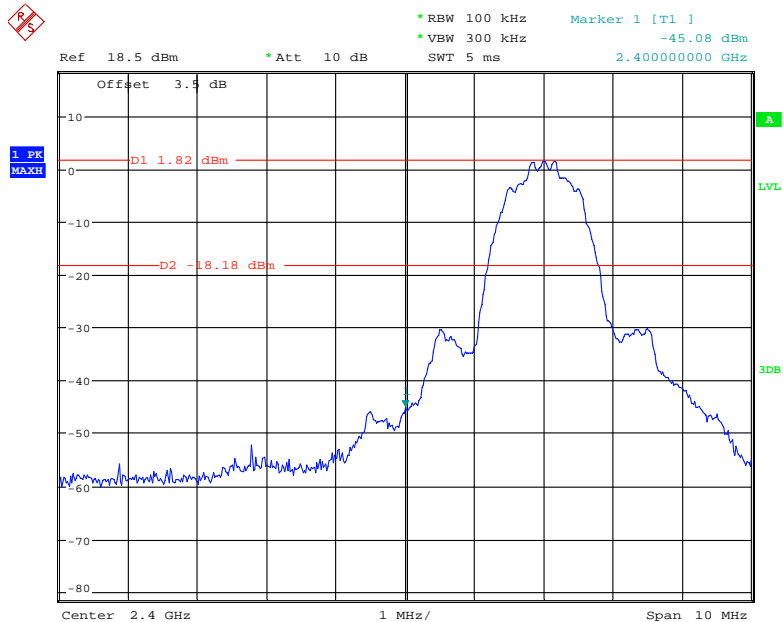

Date: 19.JUN.2019 16:21:12

EDR ($\pi/4$ -DQPSK): Band Edge-Right Side Hopping

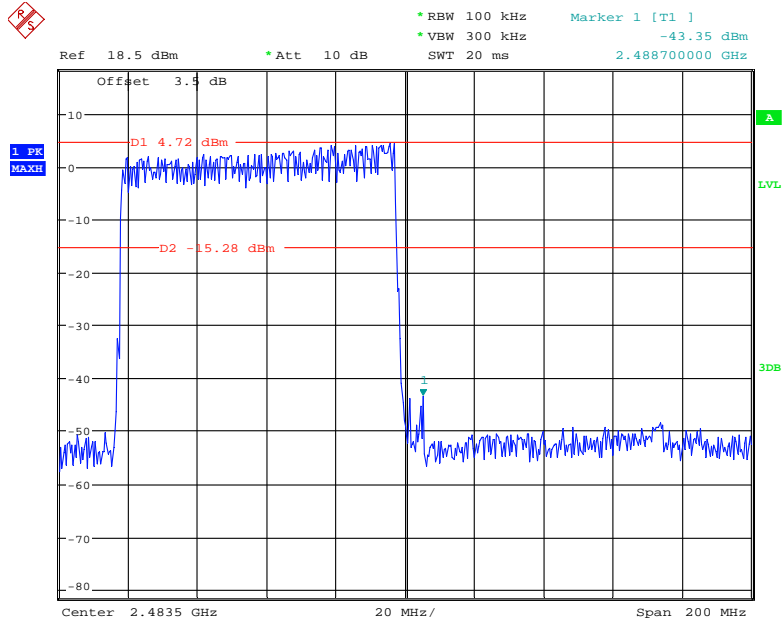

Date: 19.JUN.2019 16:08:42

Single

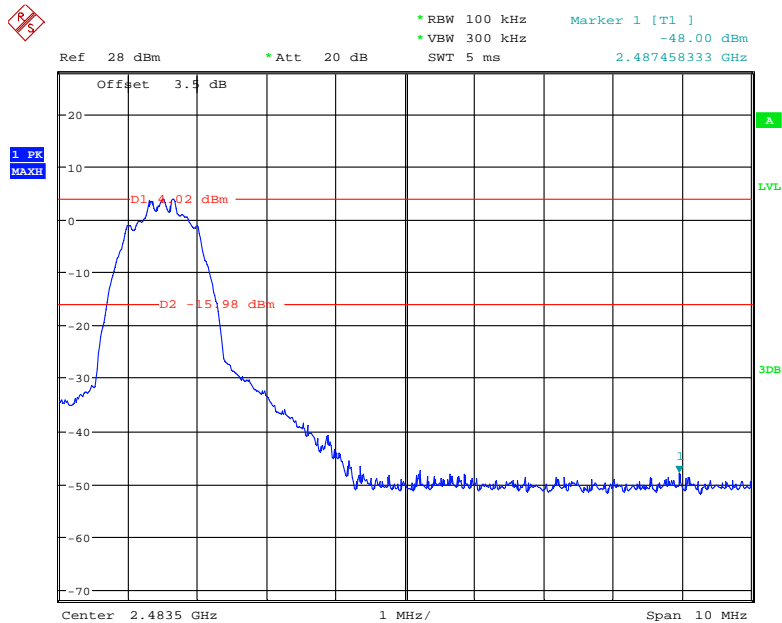

Date: 5.JUL.2019 14:25:51

EDR (8DPSK): Band Edge-Left Side Hopping

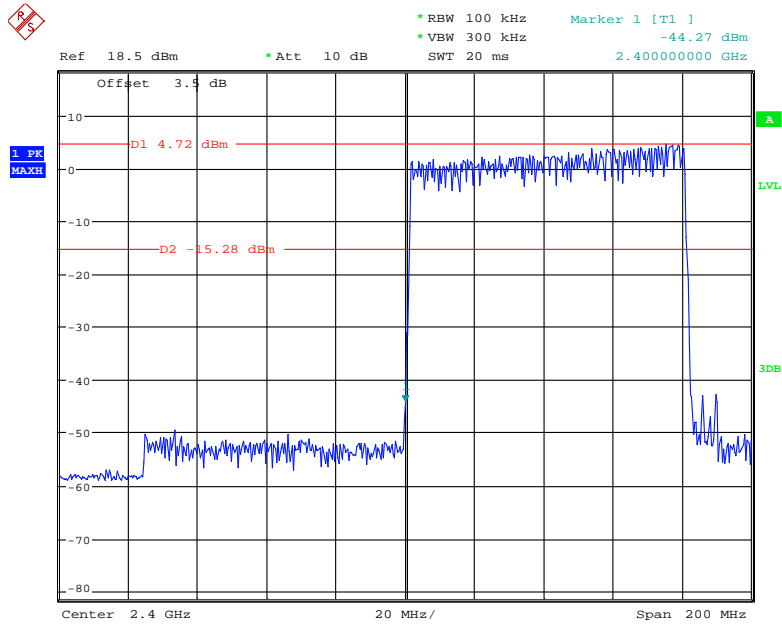

Date: 19.JUN.2019 16:03:57

Single

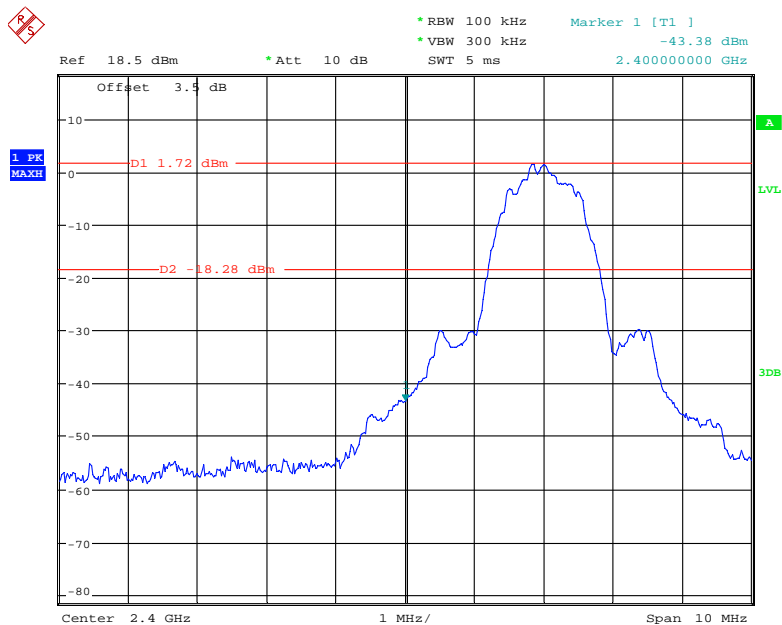

Date: 19.JUN.2019 16:24:45

EDR (8DPSK): Band Edge-Right Side Hopping

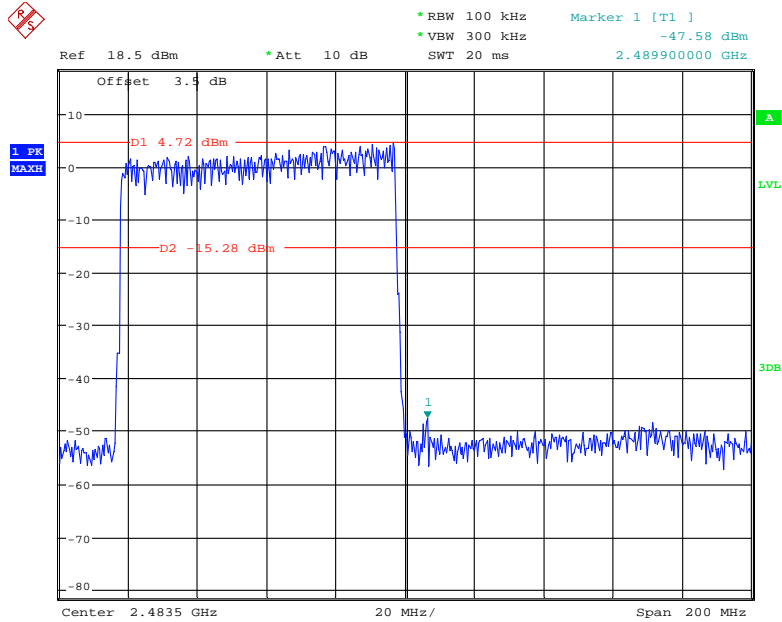

Date: 19.JUN.2019 16:06:25

Single

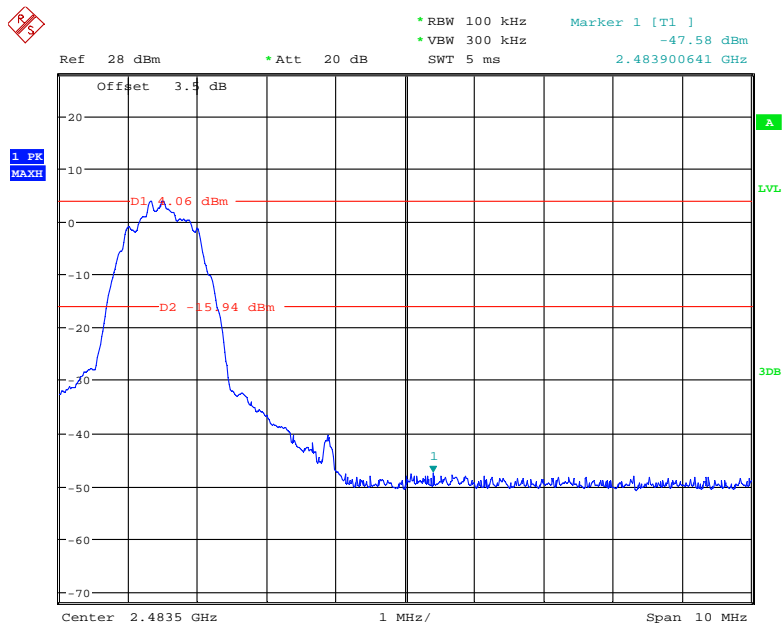

Date: 5.JUL.2019 14:28:24

***** END OF REPORT *****