



The ISAAC InMetrics is a stand-alone data recorder for ISAAC Instruments' vehicle telemetry and a wireless Internet access point.

It captures and transmits the data collected from sensors and the vehicle's CAN bus to the vehicle telemetry server, and also provides wireless connectivity for external devices such as the ISAAC InControl rugged tablet and ISAAC InView camera solution.

The built-in components of the ISAAC InMetrics feature a GNSS, and allow for cellular, Wi-Fi and Bluetooth communication.

The ISAAC InMetrics allows connecting a communication module (ex. satellite – Iridium), IDN modules (ISAAC Device Network) and 4 digital inputs.

Features

- Resistant to extreme environment:
 - High vibration and shockproof
 - Water and humidity resistance
 - Wide operating temperature range (-40° to 85°C)
 - SAE J1455 compliant design guidelines
- Wide voltage operating range – 9 V to 32 V, cold cranking tolerant (6.5 V)
- Excellent immunity to radio frequency interference, electrostatic discharge and high voltage transient
- 1.5 GB memory – data retention in case of power loss
- Low power consumption with configurable sleep and wake up timer
- FCC, IC and PTCRB certified
- Over-the-air (OTA) software updates
- Wi-Fi – WLAN 802.11 b/g/n
- Cellular communication
 - North America
 - 2 SIM cards
 - LTE (4G)
 - Fallback 3G
- Positioning
 - GNSS (GPS, GLONASS, Galileo, Beidou)
 - High sensitivity tracking, small time to first fix
- Compatible with ISAAC Instruments:
 - ISAAC Device Network modules (IDNxxx)
 - External satellite communication modules (COMSA1)
 - ISAAC InView camera solution

Internal sensors

- 3 accelerometers and gyroscopes for measuring forces on lateral, longitudinal and vertical axes
- Temperature and voltage.

External ports

- Diagnostic ports
 - 3 CAN bus ports (HS-CAN 2.0A/B)
 - 1 SAE J1708 bus port
 - Communication RS232 Port (COM), allows for an alternate mode of communication (ex. satellite)
- 4 digital inputs
- Tablet recharge port

Operation Details

Circuit Protection

The recorder features built-in fuses that provide circuit protection to the entire system and peripherals. The recorder also includes protection against reverse polarity and supply over-voltage. In the event of reverse polarity (≤ 70 V) or voltage outside operating range (32 – 70 V), the recorder automatically shuts down to avoid damage, and resumes operation when voltage returns to operating range.

EMI/RFI and Electrostatic Discharge Protection

All power and signal wires connected to the system are shielded and filtered against electromagnetic/radio frequency interference to offer excellent data collection in highly radiated environments. ISAAC Instruments recorders and peripherals undergo rigorous EMI/RFI testing to ensure system reliability in the harshest environments.

Vehicle Data Ports (CAN)

The CAN 2.0 A/2.0B ports are capable of recording information from:

- Diagnostic on CAN (ISO 15765)
- OBD on CAN SAE J1979
- SAE J1939
- CAN Bus compatible electronic devices
- Single frame broadcast messages with standard (11 bit) or extended (29 bit) identifiers

The SAE J1708 port is capable of recording information from SAE J1708/SAE J1587 and SAE J1922 data links.

Note: only 3 diagnostic ports can be activated simultaneously

Internal Accelerometers and Gyroscopes

The 3 accelerometers and gyroscopes measure the longitudinal, lateral and vertical forces the recorder is subjected to.

Digital Inputs

The input measures the state of an input.

The recorder can be configured to apply pull-up (default) or pull-down resistance:

- Use *pull-up* when signal input switches to 0 V (GND)
- Use *pull-down* when signal input switches to +V

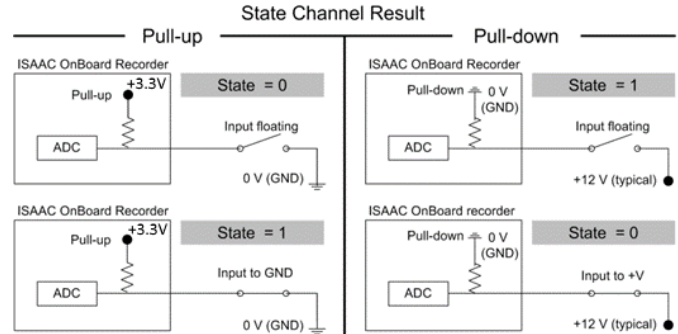

Shutdown Timer

The recorder features a shutdown timer that can be used to automatically power off the recorder after a set amount of time, in order to avoid battery drainage. The shutdown timer delay is configurable.

Shutdown timer logic:

- When ground or an open signal is detected to the SHTDWN cable, the countdown to power shutdown begins. (Shutdown power consumption is less than 1 μ A.)
- When a high signal level (3 to 35 Vdc) is detected on the SHTDWN cable, the timer is reset, and the recorder is powered on.

Wake-up Feature

The recorder includes a wake-up timer feature that can be used to communicate with the system server at regular intervals.

Designed to work in conjunction with the shutdown timer, the wake-up feature lets system users know that the recorder is still functional, although it has been shut down. The wake-up time interval and duration are configurable.

Automatic Over-the-air (OTA) software updates

Configuration and firmware updates are completed over-the-air (OTA).

Specifications

Description	Min	Typical	Max	Unit
Electrical Specifications				
VDP (Vehicle Data and Power)				
Input voltage - V_{in}^1	9		32	V
Input current @ 12.0 V				
Router mode		280		mA
Router mode – Cellular disabled		220		mA
Client mode – Wi-Fi		240		mA
IDN (ISAAC Device Network)				
Output voltage	V_{in}		V_{in}	V
Total output current	0.5		500	mA
Environmental Specifications				
Operating temperature	-40 (-40)		85 (185)	°C (°F)
Storage temperature	-40 (-40)		85 (185)	°C (°F)
External Antenna connectors				
Wi-Fi	Fakra (pastel green) 50 Ohm			
Cellular	Fakra (magenta) 50 Ohm			
GPS	Fakra (blue) 50 Ohm			
Diagnostic Ports				
HSCAN Interface				
Standard		ISO 11898-2		
Bit Rate	10		1000	Kbit/sec
DC voltage at pin CANH/CANL	-27		40	V
Transient voltage at pin CANH/CANL	-200		200	V
SAE J1708 Interface				
Bit rate		9.6		Kbit/sec
DC voltage at pin A	-10		15	V
DC voltage at pin B	-10		15	V
Internal accelerometer				
±2G resolution X, Y and Z		0.00195		g/bit
Internal temperature sensor				
Accuracy over measuring range ²		±2		C
Resolution		0.12207		C/bit
Digital Inputs (A1-A4)				
Digital input low voltage	-35		1	V
Digital input high voltage	2.3		35	V
Internal pull-up resistor		1		MΩ
Cellular transceiver				
LTE Cat 1				
Upload		5		Mbps
Download		10		Mbps
Frequencies				
LTE 4G band	B2(1900), B4(AWS1700), B12(700)			MHz
3G band	B2(1900), B4(AWS1700), B5(850)			MHz
Wi-Fi transceiver				
Standard	IEEE 802.11 b/g/n			
Protocols	WAP, WEP, WPA-II			
RF frequency range	2412		2472	MHz
RF data rate	1	802.11 b/g/n rates supported	65	Mbps

¹ Cold cranking tolerant (6.5 V)

² Sensor measures the recorder's internal temperature which exceeds the ambient temperature by 10° Celsius on average.

Description	Min	Typical	Max	Unit
GNSS receiver (GPS, GLONASS, Galileo, Beidou)				
Sensitivity				
Tracking		-167		dBm
Cold start		-148		dBm
Differential GPS	RTCM, SBAS (WAAS, EGNOS, MSAS, GAGAN, QZSS)			
Update rate		1		Hz
Position accuracy (CEP)				
GPS + GLONASS		2.5		m
Time to first fix - (with nominal GPS signal levels -130dBm)				
Cold start		26		s
Hot start		1		s
Certifications / testing method				
Electrical				
Operating voltage input	SAE J1455			
Radiated immunity	ISO11452-2 (2004)			
Magnetic field immunity	ISO11452-8 (2008)			
Bulk current injection immunity (BCI)	ISO11452-4 (2011)			
Electrostatic discharge immunity	ISO10605 (2008)			
Conducted transient immunity	SAE J1113-11 (2012)			
Environmental				
Ingress protection	IP64 / SAE J1455			
Low temperature	-40°C - MIL-STD 810G – method 502.5 / SAE J1455			
High temperature	85°C - MIL-STD 810G – method 501.5 / SAE J1455			
Thermal shock	-40°C to 85°C - MIL-STD 810G – method 503.5 / SAE J1455			
Mechanical				
Mechanical shock / crash test	75 g - MIL-STD 810G – method 516.7 / SAE J1455			
Random vibration	8 grms - MIL-STD 810G – method 514.7 / SAE J1455			
Radiofrequency				
Cellular	PTCRB			
Approved carriers	Bell and AT&T			
Intentional emitters	FCC (Federal Communication Commission) and IC (Industry Canada)			
Mechanical Specifications				
Height		41 (1.6)		mm (in)
Depth – recorder only, no attached harness		111 (4.4142)		mm (in)
Width		142 (5.6)		mm (in)
Weight		225 (0.5)		g (lbs)

LED description



STAT.	
No LED	Unit is powered off
Blinking LED	Not recording
Solid LED	Recording
CODE	
Solid LED	System update in progress
1 blink - pause	Low voltage detected
2 blinks - pause	Recorder not level (> 0.1g)
4 blinks - pause	Internal communication fault
Wi-Fi / BT	
No LED	Wi-Fi / BT starting
Solid LED	No Wi-Fi / BT module connected
Blinking LED	Wi-Fi / BT module connected
SERV.	
Solid LED	No communication with ISAAC server
Blinking LED	Communication with ISAAC server is active
LTE	
No LED	Cellular starting
Solid LED	No communication with cellular network
Blinking LED	Communication with cellular network active
GPS	
No LED	No position received
Blinking LED	Valid position received

Certification

FCC Interference Notice

This device complies with Part 15 of the FCC Rules. Operation is subject to the following two conditions:

1. This device may not cause harmful interference, and
2. This device must accept any interference received, including interference that may cause undesired operation.

Industry Canada Notice

3. This device complies with Industry Canada license-exempt RSS standard(s). Operation is subject to the following two conditions: (1) this device may not cause interference, and (2) this device must accept any interference, including interference that may cause undesired operation of the device.

Le présent appareil est conforme aux CNR d'Industrie Canada applicable aux appareils radio exempts de licence. L'exploitation est autorisée aux deux conditions suivantes : (1) l'appareil ne doit pas produire de brouillage, et (2) l'utilisateur de l'appareil doit accepter tout brouillage radioélectrique subi, même si le brouillage est susceptible d'en compromettre le fonctionnement.

Device label :

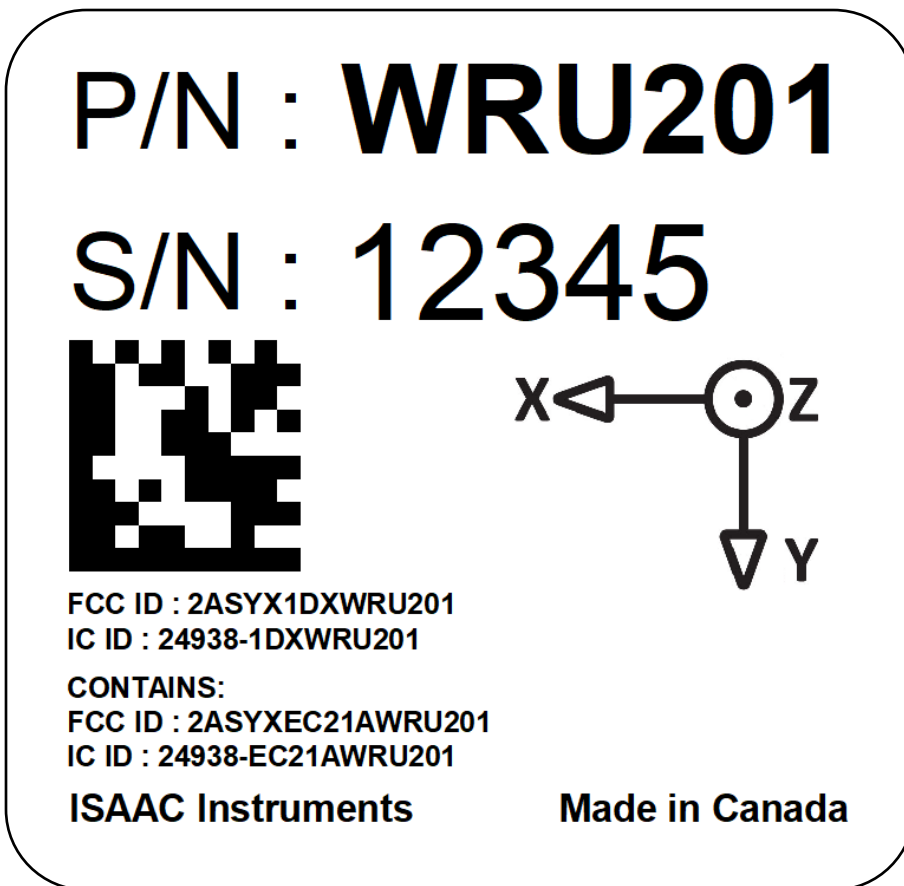

P/N : WRU201

S/N : 12345

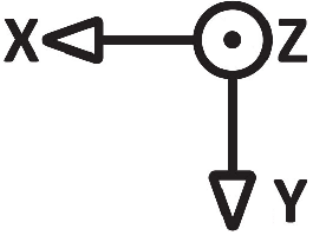
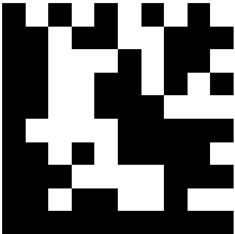

FCC ID : 2ASYX1DXWRU201
IC ID : 24938-1DXWRU201

CONTAINS:
FCC ID : 2ASYXEC21AWRU201
IC ID : 24938-EC21AWRU201

ISAAC Instruments **Made in Canada**

Antenna limitation

The Wifi radio transmitter IC: **24938-1DXWRU201** has been approved by Innovation, Science and Economic Development Canada (ISED) to operate with the antenna types listed below, with the maximum permissible gain indicated.

Antennas type not included in this list that have a gain greater than the maximum gain indicated for any type listed are strictly prohibited for use with this device.

ISAAC Part number	Antenna type	Impedance (Ohm)	Peak gain (dBi)	Photos
WRLWFI-F01	Omnidirectional external	50	3.5	
WRLWFI-F04	Omnidirectional external	50	2.6	