



FCC REPORT

For WCDMA



Report No. : **CHTEW23100033** Report Verification: 

Project No...... : **SHT2309044601EW**

FCC ID..... : **2ASWW-FLIPK**

Applicant : **XINCHUANGXIN INTERNATIONAL CO.,LTD**

Address..... : **ROOM 605 6/F, FA YUEN COMMERCIAL BUILDING, 75-77 FA YUEN STREET MONGKOK KL**

Product Name : **Feature phone**

Trade Mark : **CORN**

Model No. : **Flip K**

Listed Model(s) : **-**

Standard : **FCC CFR Title 47 Part 2**
FCC CFR Title 47 Part 22 Subpart H
FCC CFR Title 47 Part 24 Subpart E

Date of receipt of test sample..... : **Sep. 14, 2023**

Date of testing..... : **Sep. 14, 2023- Oct. 10, 2023**

Date of issue..... : **Oct. 13, 2023**

Result..... : **Pass**

Compiled by
 (position+printedname+signature)....: File administrators Xiaodong Zhao 

Supervised by
 (position+printedname+signature)....: Project Engineer Xiaodong Zhao 

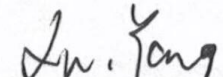
Approved by
 (position+printedname+signature)....: Manager Xu Yang 

Testing Laboratory Name : **Shenzhen Huatongwei International Inspection Co., Ltd.**

Address..... : **1/F, Bldg 3, Hongfa Hi-tech Industrial Park, Genyu Road, Tianliao, Gongming, Shenzhen, China**

Shenzhen Huatongwei International Inspection Co., Ltd. All rights reserved.

This publication may be reproduced in whole or in part for non-commercial purposes as long as the Shenzhen Huatongwei International Inspection Co., Ltd. is acknowledged as copyright owner and source of the material. Shenzhen Huatongwei International Inspection Co., Ltd. takes no responsibility for and will not assume liability for damages resulting from the reader's interpretation of the reproduced material due to its placement and context.

The test report merely correspond to the test sample.

Contents

1.	TEST STANDARDS AND REPORT VERSION	3
1.1.	Applicable Standards	3
1.2.	Report version information	3
2.	TEST DESCRIPTION	4
3.	SUMMARY	5
3.1.	Client Information	5
3.2.	Product Description	5
3.3.	Radio Specification Description	5
3.4.	Testing Laboratory Information	6
4.	TEST CONFIGURATION	7
4.1.	Test frequency list	7
4.2.	Test mode	7
4.3.	Test sample information	7
4.4.	Support unit used in test configuration and system	8
4.5.	Testing environmental condition	8
4.6.	Statement of the measurement uncertainty	8
4.7.	Equipments Used during the Test	9
5.	TEST CONDITIONS AND RESULTS	10
5.1.	Conducted Output Power	10
5.2.	Peak-Average Ratio	11
5.3.	99% Occupied Bandwidth & 26 dB Bandwidth	12
5.4.	Band Edge	13
5.5.	Conducted Spurious Emissions	14
5.6.	Frequency stability VS Temperature measurement	15
5.7.	Frequency stability VS Voltage measurement	16
5.8.	ERP and EIRP	17
5.9.	Radiated Spurious Emission	18
6.	TEST SETUP PHOTOS OF THE EUT	24
7.	EXTERNAL AND INTERNAL PHOTOS OF THE EUT	24
8.	APPENDIX REPORT	24

1. TEST STANDARDS AND REPORT VERSION

1.1. Applicable Standards

The tests were performed according to following standards:

[FCC CFR Title 47 Part 2](#): Frequency Allocations and Radio Treaty Matters; General Rules and Regulations

[FCC CFR Title 47 Part 22 Subpart H](#): Cellular Radiotelephone Service

[FCC CFR Title 47 Part 24 Subpart E](#): Broadband PCS

[ANSI C63.26-2015](#): American National Standard for Compliance Testing of Transmitters Used in Licensed Radio Services

[KDB 971168 D01 Power Meas License Digital Systems v03](#): MEASUREMENT GUIDANCE FOR CERTIFICATION OF LICENSED DIGITAL TRANSMITTERS

1.2. Report version information

Revision No.	Date of issue	Description
N/A	2023-10-13	Original

2. TEST DESCRIPTION

Section	Test Item	Section in CFR 47	Result #1	Test Engineer
5.1	Conducted Output Power	Part 2.1046 Part 22.913(a) Part 24.232(c)	Pass	Xiaodong Zhao
5.2	Peak-to-Average Ratio	Part 24.232	Pass	Xiaodong Zhao
5.3	99% Occupied Bandwidth & 26 dB Bandwidth	Part 2.1049 Part 22.917(b) Part 24.238(b)	Pass	Xiaodong Zhao
5.4	Band Edge	Part 2.1051 Part 22.917 Part 24.238	Pass	Xiaodong Zhao
5.5	Conducted Spurious Emissions	Part 2.1051 Part 22.917 Part 24.238	Pass	Xiaodong Zhao
5.6	Frequency stability vs temperature	Part 2.1055(a)(1)(b) Part 22.355 Part 24.235	Pass	Xiaodong Zhao
5.7	Frequency stability vs voltage	Part 2.1055(d)(1)(2) Part 22.355 Part 24.235	Pass	Xiaodong Zhao
5.8	ERP and EIRP	Part 22.913(a) Part 24.232(b)	Pass	Xiaodong Zhao
5.9	Radiated Spurious Emissions	Part 2.1053 Part 22.917 Part 24.238	Pass	Yifan Wang

Note:

#1: The test result does not include measurement uncertainty value

3. SUMMARY

3.1. Client Information

Applicant:	XINCHUANGXIN INTERNATIONAL CO.,LTD
Address:	ROOM 605 6/F, FA YUEN COMMERCIAL BUILDING, 75-77 FA YUEN STREET MONGKOK KL
Manufacturer:	Shenzhen Chiteng Technology Co.,LTD
Address:	Second Floor,Area A, Building 4, Huiye Technology Workshop, Guangang Road, Tangjia Community, Gongming Street, Guangming New District, Shenzhen, Guangdong

3.2. Product Description

Main unit information:	
Product Name:	Feature phone
Trade Mark:	CORN
Model No.:	Flip K
Listed Model(s):	-
Power supply:	DC 3.7V from Li-ion Battery
Hardware version:	ZS586TF_MB_V1.0
Software version:	ZS586TF_240320_F24401_FLIP_K_CORN_EnFrPoSp_V01
Accessory unit information:	
Battery information:	BL-4C Voltage: 3.7V Capacity: 800mAh 3.7V Li-ion BATTERY 2.96Wh 3.7V Li-ion BATERIA 2.96Wh
Adapter information:	Model: FSF-01 INPUT: 100-240V~50/60Hz 0.15A OUTPUT: DC 5.0V, 500mA

3.3. Radio Specification Description

Support Operating Band:	<input checked="" type="checkbox"/> Band II <input type="checkbox"/> Band IV <input checked="" type="checkbox"/> Band V
Operating Frequency Range:	Please refer to note #2
Support Type:	<input checked="" type="checkbox"/> WCDMA <input checked="" type="checkbox"/> HSDPA <input checked="" type="checkbox"/> HSUPA <input type="checkbox"/> DC-HSUPA
Modulation Type:	<input checked="" type="checkbox"/> QPSK <input type="checkbox"/> 16QAM
Power Class:	<input checked="" type="checkbox"/> Class 3 <input type="checkbox"/> Class 4
Antenna type:	Internal
Antenna gain #3:	Band II: 0.82dBi Band V: -1.23dBi

Note:

- : means that this feature is supported; : means that this feature is not supported
- #2: Operating frequency range is as follow:

WCDMA Band	Uplink frequency	Downlink frequency
Band II	1852.40~1907.60MHz	1932.40~1987.60MHz
Band V	826.40~846.60MHz	871.40~891.60MHz

- #3: The antenna gain is provided by the applicant, and the applicant should be responsible for its authenticity, HTW lab has not verified the authenticity of its information

3.4. Testing Laboratory Information

Laboratory Name	Shenzhen Huatongwei International Inspection Co., Ltd.	
Laboratory Location	1/F, Bldg 3, Hongfa Hi-tech Industrial Park, Genyu Road, Tianliao, Gongming, Shenzhen, China	
Connect information:	Tel: 86-755-26715499 E-mail: cs@szhtw.com.cn http://www.szhtw.com.cn	
Qualifications	Type	Accreditation Number
	FCC	762235

4. TEST CONFIGURATION

4.1. Test frequency list

FDD Band II		FDD Band V	
Channel	Frequency (MHz)	Channel	Frequency (MHz)
9262	1852.40	4132	826.40
9400	1880.00	4182	836.40
9538	1907.60	4233	846.60

4.2. Test mode

Test mode	Link mode
-----------	-----------

- 1) Antenna port conducted and radiated test items were performed according to KDB 971168 D01 Power Meas. License Digital Systems and ANSI C63.26 with maximum output power.
- 2) Radiated measurements were performed with rotating EUT in different three orthogonal test planes to find the maximum emission.

All modes and data rates and positions were investigated, test modes are chosen to be reported as the worst case configuration below:

Band	Radiated test items	Conducted test items
WCDMA Band V	RMC 12.2Kbps Link	RMC 12.2Kbps Link
WCDMA Band II	RMC 12.2Kbps Link	RMC 12.2Kbps Link

4.3. Test sample information

Test item	HTW sample no.
Conducted test items	Please refer to the description in the appendix report
Radiated test items	YPHT23090446001

Note:

Conducted test items: Conducted Output Power, Peak-Average Ratio, 99% Occupied Bandwidth & 26 dB Bandwidth, Band Edge, Conducted Spurious Emissions, Frequency stability, ERP and EIRP

Radiated test items: Radiated Spurious Emission

4.4. Support unit used in test configuration and system

The EUT has been associated with peripherals and configuration operated in a manner tended to maximize its emission characteristics in a typical application.

The following peripheral devices and interface cables were connected during the measurement:

Whether support unit is used?				
✓ No				
Item	Equipment	Trade Name	Model No.	Other
1				
2				

4.5. Testing environmental condition

Voltage	VN=Nominal Voltage	DC 3.70V
	VL=Lower Voltage	DC 3.33V
	VH=Higher Voltage	DC 4.07V
Temperature	TN=Normal Temperature	25 °C
	Extreme Temperature	From -30°C to + 50°C
Humidity	30~60 %	
Air Pressure	950-1050 hPa	

4.6. Statement of the measurement uncertainty

No.	Test Items	Measurement Uncertainty
1	Conducted Output Power	0.66
2	Peak-to-Average Ratio	-
3	99% Occupied Bandwidth & 26 dB Bandwidth	0.002%
4	Band Edge	1.68dB
5	Conducted Spurious Emissions	1.68dB
6	Frequency stability	0.02ppm
7	Radiated Spurious Emission	4.54dB for 30MHz-1GHz 5.10dB for above 1GHz

This uncertainty represents an expanded uncertainty expressed at approximately the 95% confidence level using a coverage factor of k=1.96.

4.7. Equipments Used during the Test

● RF Conducted test item							
Used	Test Equipment	Manufacturer	Equipment No.	Model No.	Serial No.	Last Cal. Date (YY-MM-DD)	Next Cal. Date (YY-MM-DD)
●	Spectrum Analyzer	Agilent	HTWE0286	N9020A	MY50510187	2023/08/22	2024/08/21
●	Radio communication tester	R&S	HTWE0287	CMW500	137688-Lv	2023/08/25	2024/08/24
●	Test software	Tonscend	N/A	JS1120	N/A	N/A	N/A
●	T-Cock	Weinschel	HTWE0289	1580	SC329	2023/08/22	2024/08/21

● Auxiliary Equipment							
Used	Test Equipment	Manufacturer	Equipment No.	Model No.	Serial No.	Last Cal. Date (YY-MM-DD)	Next Cal. Date (YY-MM-DD)
●	Climate chamber	ESPEC	HTWS0715	GPL-2	N/A	2023/08/21	2024/08/20
●	DC Power Supply	Gwinstek	HTWE0274	SPS-2415	GER835793	N/A	N/A

● Radiated Spurious Emission							
Used	Test Equipment	Manufacturer	Equipment No.	Model No.	Serial No.	Last Cal. Date (YY-MM-DD)	Next Cal. Date (YY-MM-DD)
●	Semi-Anechoic Chamber	Albatross projects	HTWE0122	SAC-3m-01	C11121	2023/4/17	2026/4/16
●	Spectrum Analyzer	R&S	HTWE0098	FSP40	100597	2023/08/22	2024/08/21
●	Spectrum Analyzer	R&S	HTWE0385	N9020A	MY54486658	2023/08/22	2024/08/21
●	Ultra-Broadband Antenna	SCHWARZBECK	HTWE0123	VULB9163	538	2021/4/6	2024/4/5
●	Horn Antenna	SCHWARZBECK	HTWE0126	BBHA 9120D	1011	2023/2/14	2026/2/13
●	Pre-Amplifier	CD	HTWE0071	PAP-0102	12004	2023/5/25	2024/5/24
●	Broadband Pre-amplifier	SCHWARZBECK	HTWE0201	BBV 9718	9718-248	2023/5/25	2024/5/24
●	Test Software	Audix	N/A	E3	N/A	N/A	N/A

● Auxiliary Equipment							
Used	Test Equipment	Manufacturer	Equipment No.	Model No.	Serial No.	Last Cal. Date (YY-MM-DD)	Next Cal. Date (YY-MM-DD)
●	Radio communication tester	R&S	HTWE0287	CMW500	137688-Lv	2023/08/25	2024/08/24
●	High pass filter	Wainwright	HTWE0297	WHKX3.0/18G-10SS	38	2023/05/15	2024/05/14
○	Band Stop filter	-	HTWE0039	N/A	N/A	2023/01/26	2024/01/25

5. TEST CONDITIONS AND RESULTS

5.1. Conducted Output Power

LIMIT

N/A

TEST CONFIGURATION

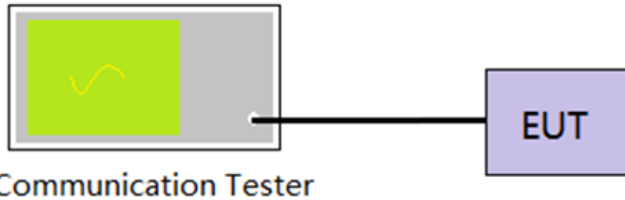

TEST PROCEDURE

1. The EUT output port was connected to communication tester.
2. Set EUT at maximum power through communication tester.
3. Select lowest, middle, and highest channels for each band and different modulation.
4. Measure the maximum burst average power.

TEST MODE

Please refer to the clause 4.2

TEST RESULTS

Passed Not Applicable

TEST DATA

Refer to the appendix report

5.2. Peak-Average Ratio

LIMIT

13dB

TEST CONFIGURATION

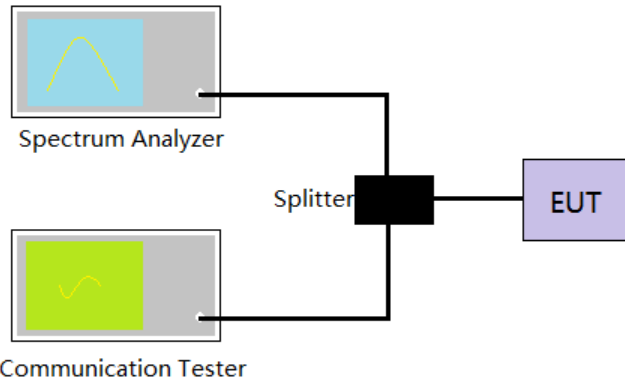

TEST PROCEDURE

1. The EUT was connected to the spectrum analyzer and communication tester via a power splitter
2. Set EUT in maximum power output.
3. Center Frequency = Carrier frequency, RBW > Emission bandwidth of signal
4. The signal analyzer was set to collect one million samples to generate the CCDF curve
5. The measurement interval was set depending on the type of signal analyzed.
 - i. For continuous signals (>98% duty cycle), the measurement interval was set to 1ms.
 - ii. For burst transmissions, the spectrum analyzer is set to use an internal " RF Burst" trigger that issynced with an incoming pulse and the measurement interval is set to less than the durationof the " on time" of one burst to ensure that energy is only captured during a time in whichthetransmitter is operating at maximum power
6. Record the maximum PAPR level associated with a probability of 0.1%.

TEST MODE

Please refer to the clause 4.2

TEST RESULTS

Passed Not Applicable

TEST DATA

Refer to the appendix report

5.3. 99% Occupied Bandwidth & 26 dB Bandwidth

LIMIT

N/A

TEST CONFIGURATION

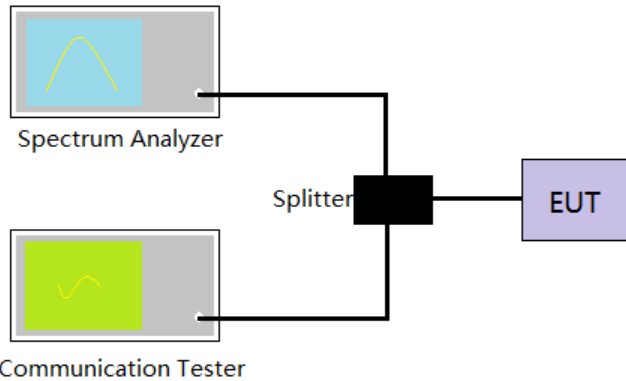

TEST PROCEDURE

1. The EUT was connected to the spectrum analyzer and communication tester via a power splitter
2. Set EUT in maximum power output.
3. Spectrum analyzer setting as follow:
Center Frequency= Carrier frequency, RBW=1% to 5% of anticipated OBW, VBW= 3 * RBW,
Detector=Peak, Trace maximum hold.
4. Record the value of 99% Occupied bandwidth and -26dB bandwidth.

TEST MODE

Please refer to the clause 4.2

TEST RESULTS

Passed Not Applicable

TEST DATA

Refer to the appendix report

5.4. Band Edge

LIMIT

Part 24.238 and Part 22.917 specify that the power of any emission outside of the authorized operating frequency ranges must be attenuated below the transmitting power (P) by a factor of at least $43 + 10 \log(P)$ dB.

The specification that emissions shall be attenuated below the transmitter power (P) by at least $43 + 10 \log(P)$ dB, translates in the relevant power range (1 to 0.001 W) to -13 dBm. At 1 W the specified minimum attenuation becomes 43 dB and relative to a 30 dBm (1 W) carrier becomes a limit of -13 dBm. At 0.001 W (0 dBm) the minimum attenuation is 13 dB, which again yields a limit of -13 dBm. In this way a translation of the specification from relative to absolute terms is carried out.

TEST CONFIGURATION

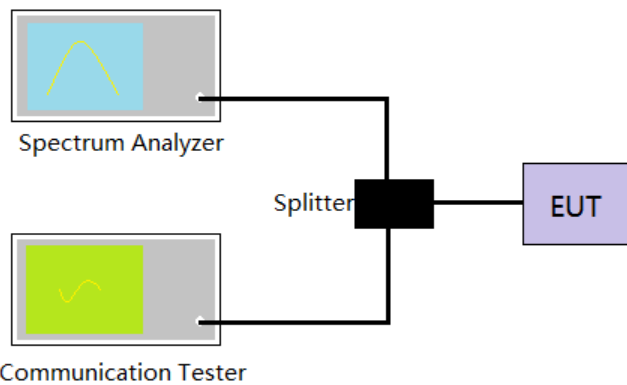

TEST PROCEDURE

1. The EUT was connected to the spectrum analyzer and communication tester via a power splitter
2. Set EUT in maximum power output.
3. The band edges of low and high channels were measured.
4. Spectrum analyzer setting as follow:
RBW=100KHz, VBW = 300KHz, Sweep time= Auto
5. Record the test plot.

TEST MODE

Please refer to the clause 4.2

TEST RESULTS

Passed Not Applicable

TEST DATA

Refer to the appendix report

5.5. Conducted Spurious Emissions

LIMIT

Part 24.238 and Part 22.917 specify that the power of any emission outside of the authorized operating frequency ranges must be attenuated below the transmitting power (P) by a factor of at least $43 + 10 \log(P)$ dB.

The specification that emissions shall be attenuated below the transmitter power (P) by at least $43 + 10 \log(P)$ dB, translates in the relevant power range (1 to 0.001 W) to -13 dBm. At 1 W the specified minimum attenuation becomes 43 dB and relative to a 30 dBm (1 W) carrier becomes a limit of -13 dBm. At 0.001 W (0 dBm) the minimum attenuation is 13 dB, which again yields a limit of -13 dBm. In this way a translation of the specification from relative to absolute terms is carried out.

TEST CONFIGURATION

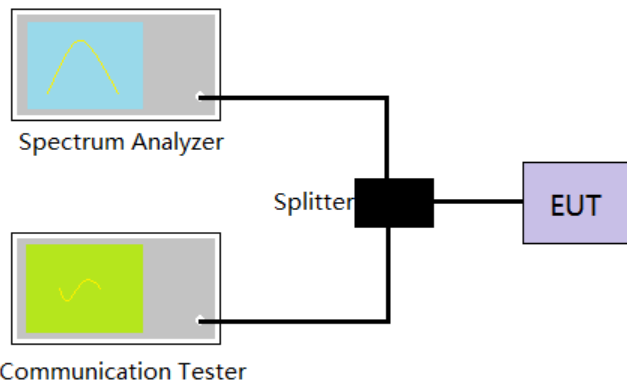

TEST PROCEDURE

1. The EUT was connected to the spectrum analyzer and communication tester via a power splitter
2. Set EUT in maximum power output.
3. Spectrum analyzer setting as follow:
Below 1GHz, RBW=100KHz, VBW = 300KHz, Detector=Peak, Sweep time= Auto
Above 1GHz, RBW=1MHz, VBW=3MHz, Detector=Peak, Sweep time= Auto
Scan frequency range up to 10th harmonic.
4. Record the test plot.

TEST MODE

Please refer to the clause 4.2

TEST RESULTS

Passed Not Applicable

TEST DATA

Refer to the appendix report

5.6. Frequency stability VS Temperature measurement

LIMIT

2.5ppm

TEST CONFIGURATION

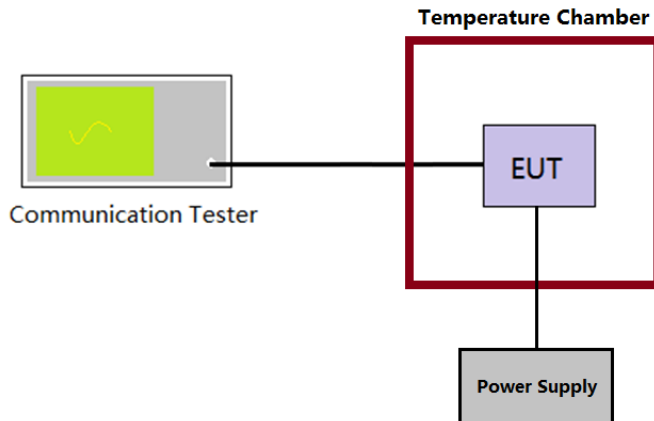

TEST PROCEDURE

1. The equipment under test was connected to an external DC power supply and input rated voltage.
2. The EUT output port was connected to communication tester.
3. The EUT was placed inside the temperature chamber.
4. Turn EUT off and set the chamber temperature to -30°C . After the temperature stabilized for approximately 30 minutes recorded the frequency.
5. Repeat step 4 measure with 10°C increased per stage until the highest temperature of $+50^{\circ}\text{C}$ reached.

TEST MODE

Please refer to the clause 4.2

TEST RESULTS

Passed Not Applicable

TEST DATA

Refer to the appendix report

5.7. Frequency stability VS Voltage measurement

LIMIT

2.5ppm

TEST CONFIGURATION

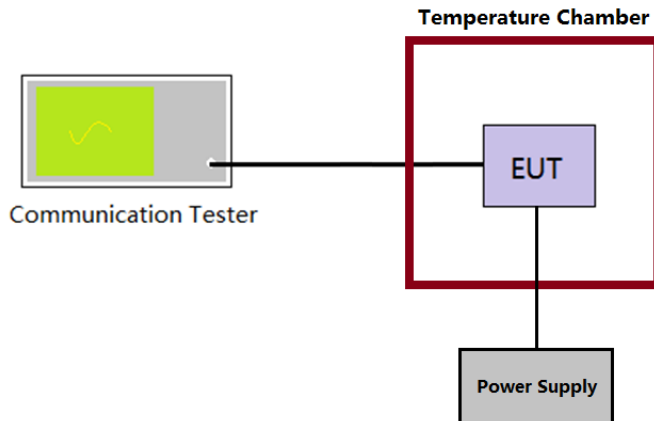

TEST PROCEDURE

1. The equipment under test was connected to an external DC power supply and input rated voltage.
2. The EUT output port was connected to communication tester.
3. The EUT was placed inside the temperature chamber at 25°C
4. The power supply voltage to the EUT was varied $\pm 15\%$ of the nominal value measured at the input to the EUT
5. Record the maximum frequency change.

TEST MODE

Please refer to the clause 4.2

TEST RESULTS

Passed Not Applicable

TEST DATA

Refer to the appendix report

5.8. ERP and EIRP

LIMIT

WCDMA Band V: 7W (38.45dBm) ERP

WCDMA Band II: 2W (33dBm) EIRP

TEST PROCEDURE

1. According to the power tested in section 5.1, select the maximum power in each mode, and use the following formula to calculate the corresponding ERP/EIRP.
2. $ERP = \text{conducted power} + \text{Gain(dBd)}$
3. $EIRP = \text{conducted power} + \text{Gain(dBi)}$
 $ERP = EIRP - 2.15$

TEST RESULTS

Passed Not Applicable

TEST DATA

Refer to the appendix report

5.9. Radiated Spurious Emission

LIMIT

-13dBm

TEST CONFIGURATION

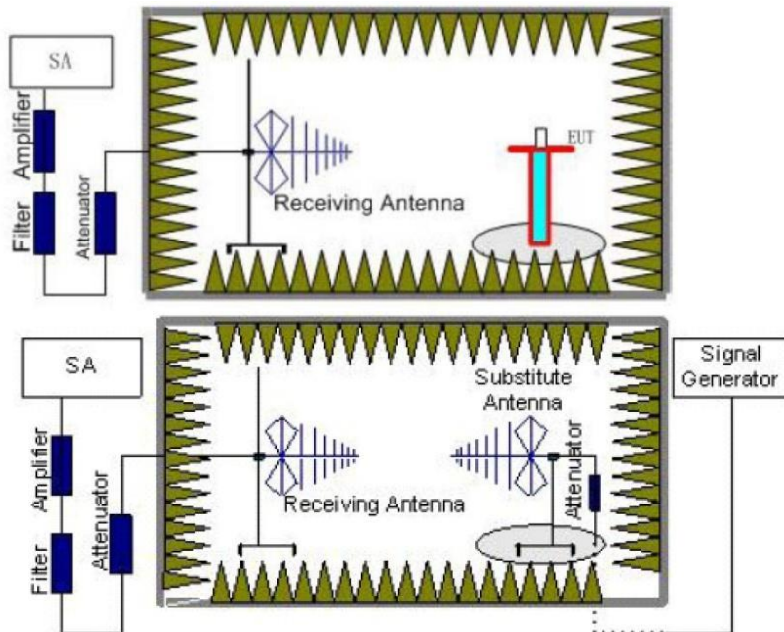

TEST PROCEDURE

- Place the EUT in the center of the turntable.
 - For radiated emissions measurements performed at frequencies less than or equal to 1 GHz, the EUT shall be placed on a RF-transparent table at a nominal height of 80 cm above the reference ground plane
 - For radiated measurements performed at frequencies above 1 GHz, the EUT shall be placed on an RF transparent table at a nominal height of 1.5 m above the ground plane.
- Unless the EUT uses an integral antenna, the EUT shall be terminated with a non-radiating transmitter load. In cases where the EUT uses an adjustable antenna, the antenna shall be adjusted through typical positions and lengths to maximize emissions levels.
- The EUT shall be tested while operating on the frequency per manufacturer specification. Set the transmitter to operate in continuous transmit mode.
- Receiver or Spectrum set as follow:
Below 1GHz, RBW=100kHz, VBW=300kHz, Detector=Peak, Sweep time=Auto
Above 1GHz, RBW=1MHz, VBW=3MHz, Detector=Peck, Sweep time=Auto
- Each emission under consideration shall be evaluated:
 - Raise and lower the measurement antenna from 1 m to 4 m, as necessary to enable detection of the maximum emission amplitude relative to measurement antenna height.
 - Rotate the EUT through 360° to determine the maximum emission level relative to the axial position.
 - Return the turntable to the azimuth where the highest emission amplitude level was observed.
 - Vary the measurement antenna height again through 1 m to 4 m again to find the height associated with the maximum emission amplitude.
 - Record the measured emission amplitude level and frequency
- Repeat step 5 for each emission frequency with the measurement antenna oriented in both the horizontal and vertical polarizations to determine the orientation that gives the maximum emissions amplitude.
- Set-up the substitution measurement with the reference point of the substitution antenna located as near

as possible to where the center of the EUT radiating element was located during the initial EUT measurement.

8. Maintain the previous measurement instrument settings and test set-up, with the exception that the EUT is removed and replaced by the substitution antenna.
9. Connect a signal generator to the substitution antenna; locate the signal generator so as to minimize any potential influences on the measurement results. Set the signal generator to the frequency where emissions are detected, and set an output power level such that the radiated signal can be detected by the measurement instrument, with sufficient dynamic range relative to the noise floor.
10. For each emission that was detected and measured in the initial test
 - a) Vary the measurement antenna height between 1 m to 4 m to maximize the received (measured) signal amplitude.
 - b) Adjust the signal generator output power level until the amplitude detected by the measurement instrument equals the amplitude level of the emission previously measured directly in step 5 and step 6.
 - c) Record the output power level of the signal generator when equivalence is achieved in step b).
11. Repeat step 8 through step 10 with the measurement antenna oriented in the opposite polarization.
12. Calculate the emission power in dBm referenced to a half-wave dipole using the following equation:
$$P_e = P_s(\text{dBm}) - \text{cable loss (dB)} + \text{antenna gain (dBd)}$$
where
 P_e = equivalent emission power in dBm
 P_s = source (signal generator) power in dBm
NOTE—dBd refers to the measured antenna gain in decibels relative to a half-wave dipole.
13. Correct the antenna gain of the substitution antenna if necessary to reference the emission power to a half-wave dipole. When using measurement antennas with the gain specified in dBi, the equivalent dipole-referenced gain can be determined from:
$$\text{gain (dBd)} = \text{gain (dBi)} - 2.15 \text{ dB.}$$
If necessary, the antenna gain can be calculated from calibrated antenna factor information
14. Provide the complete measurement results as a part of the test report.

TEST MODE

Please refer to the clause 4.2

TEST RESULTS

Passed **Not Applicable**

WCDMA Band II										
Test channel:		9262			Polarization:			Horizontal		
Mark	Frequency MHz	Reading dBm	Antenna dB	Cable dB	Preamp dB	Level dBm	Limit dBm	Over limit	Remark	
1	43.71	-78.39	26.09	1.21	30.55	-81.64	-13.00	-68.64	Peak	
2	948.05	-73.77	29.40	6.35	29.27	-67.29	-13.00	-54.29	Peak	
3	3786.01	-64.97	42.20	5.20	37.10	-54.67	-13.00	-41.67	Peak	
4	5448.41	-66.84	43.99	6.59	35.33	-51.59	-13.00	-38.59	Peak	
5	7413.73	-66.32	48.49	7.84	34.22	-44.21	-13.00	-31.21	Peak	
6	10971.98	-68.04	52.84	9.99	35.91	-41.12	-13.00	-28.12	Peak	
Test channel:		9262			Polarization:			Vertical		
Mark	Frequency MHz	Reading dBm	Antenna dB	Cable dB	Preamp dB	Level dBm	Limit dBm	Over limit	Remark	
1	97.78	-80.70	25.78	1.85	30.65	-83.72	-13.00	-70.72	Peak	
2	773.13	-75.56	29.21	5.67	29.49	-70.17	-13.00	-57.17	Peak	
3	3893.52	-62.94	41.79	5.30	37.10	-52.95	-13.00	-39.95	Peak	
4	5546.36	-65.34	43.96	6.49	35.25	-50.14	-13.00	-37.14	Peak	
5	7781.10	-65.68	48.53	7.82	33.73	-43.06	-13.00	-30.06	Peak	
6	10888.51	-66.21	52.69	9.95	35.93	-39.50	-13.00	-26.50	Peak	

Test channel:		9400			Polarization:			Horizontal		
Mark	Frequency MHz	Reading dBm	Antenna dB	Cable dB	Preamp dB	Level dBm	Limit dBm	Over limit	Remark	
1	39.75	-79.85	27.74	1.15	30.61	-81.57	-13.00	-68.57	Peak	
2	773.13	-78.87	29.57	5.67	29.49	-73.12	-13.00	-60.12	Peak	
3	4181.16	-65.53	42.18	5.61	36.73	-54.47	-13.00	-41.47	Peak	
4	5420.74	-66.55	44.04	6.55	35.37	-51.33	-13.00	-38.33	Peak	
5	7921.00	-66.17	48.03	7.95	33.71	-43.90	-13.00	-30.90	Peak	
6	11457.21	-66.53	52.97	10.33	36.13	-39.36	-13.00	-26.36	Peak	
Test channel:		9400			Polarization:			Vertical		
Mark	Frequency MHz	Reading dBm	Antenna dB	Cable dB	Preamp dB	Level dBm	Limit dBm	Over limit	Remark	
1	90.82	-79.71	25.88	1.78	30.69	-82.74	-13.00	-69.74	Peak	
2	812.15	-79.46	29.64	5.81	29.53	-73.54	-13.00	-60.54	Peak	
3	3700.26	-62.94	42.32	5.19	37.04	-52.47	-13.00	-39.47	Peak	
4	5022.19	-65.52	44.44	6.10	35.61	-50.59	-13.00	-37.59	Peak	
5	7800.94	-65.45	48.56	7.81	33.75	-42.83	-13.00	-29.83	Peak	
6	11933.47	-67.20	52.99	10.66	36.37	-39.92	-13.00	-26.92	Peak	

Test channel:		9538			Polarization:		Horizontal		
Mark	Frequency MHz	Reading dBm	Antenna dB	Cable dB	Preamp dB	Level dBm	Limit dBm	Over limit	Remark
1	39.75	-79.25	27.74	1.15	30.61	-80.97	-13.00	-67.97	Peak
2	948.05	-75.83	29.40	6.35	29.27	-69.35	-13.00	-56.35	Peak
3	3903.44	-64.31	41.69	5.31	37.01	-54.32	-13.00	-41.32	Peak
4	5164.81	-65.24	44.02	6.32	35.30	-50.20	-13.00	-37.20	Peak
5	7860.74	-65.84	47.96	7.90	33.74	-43.72	-13.00	-30.72	Peak
6	11963.89	-67.09	52.59	10.68	36.38	-40.20	-13.00	-27.20	Peak

Test channel:		9538			Polarization:		Vertical		
Mark	Frequency MHz	Reading dBm	Antenna dB	Cable dB	Preamp dB	Level dBm	Limit dBm	Over limit	Remark
1	94.74	-79.98	25.82	1.82	30.67	-83.01	-13.00	-70.01	Peak
2	823.65	-80.29	29.80	5.85	29.34	-73.98	-13.00	-60.98	Peak
3	3719.15	-65.11	42.26	5.20	36.98	-54.63	-13.00	-41.63	Peak
4	5689.36	-67.35	44.00	6.58	35.28	-52.05	-13.00	-39.05	Peak
5	7941.19	-66.39	47.89	7.97	33.82	-44.35	-13.00	-31.35	Peak
6	11399.03	-68.62	53.13	10.29	36.10	-41.30	-13.00	-28.30	Peak

WCDMA Band V										
Test channel:		4132			Polarization:			Horizontal		
Mark	Frequency MHz	Reading dBm	Antenna dB	Cable dB	Preamp dB	Level dBm	Limit dBm	Over limit	Remark	
1	39.75	-79.95	27.74	1.15	30.61	-81.67	-13.00	-68.67	Peak	
2	767.71	-76.91	29.39	5.64	29.46	-71.34	-13.00	-58.34	Peak	
3	3342.04	-64.98	40.09	4.88	37.79	-57.80	-13.00	-44.80	Peak	
4	6283.16	-67.95	45.67	7.03	34.58	-49.83	-13.00	-36.83	Peak	
5	9759.59	-70.01	50.44	9.46	33.66	-43.77	-13.00	-30.77	Peak	
6	10860.83	-69.23	52.57	9.93	35.94	-42.67	-13.00	-29.67	Peak	

Test channel:		4132			Polarization:			Vertical		
Mark	Frequency MHz	Reading dBm	Antenna dB	Cable dB	Preamp dB	Level dBm	Limit dBm	Over limit	Remark	
1	94.74	-79.15	25.82	1.82	30.67	-82.18	-13.00	-69.18	Peak	
2	948.05	-73.86	29.13	6.35	29.27	-67.65	-13.00	-54.65	Peak	
3	3192.37	-67.01	41.46	4.80	37.43	-58.18	-13.00	-45.18	Peak	
4	4559.15	-67.36	43.40	6.36	36.14	-53.74	-13.00	-40.74	Peak	
5	8002.06	-69.52	47.61	8.00	33.88	-47.79	-13.00	-34.79	Peak	
6	10805.68	-68.86	52.61	9.91	35.96	-42.30	-13.00	-29.30	Peak	

Test channel:		4183			Polarization:			Horizontal		
Mark	Frequency MHz	Reading dBm	Antenna dB	Cable dB	Preamp dB	Level dBm	Limit dBm	Over limit	Remark	
1	40.74	-80.12	27.43	1.16	30.59	-82.12	-13.00	-69.12	Peak	
2	773.13	-72.01	29.57	5.67	29.49	-66.26	-13.00	-53.26	Peak	
3	3176.16	-64.81	41.33	4.73	37.24	-55.99	-13.00	-42.99	Peak	
4	5151.68	-66.89	44.05	6.28	35.32	-51.88	-13.00	-38.88	Peak	
5	8002.06	-69.28	48.12	8.00	33.88	-47.04	-13.00	-34.04	Peak	
6	10916.26	-67.43	52.71	9.96	35.92	-40.68	-13.00	-27.68	Peak	

Test channel:		4183			Polarization:			Vertical		
Mark	Frequency MHz	Reading dBm	Antenna dB	Cable dB	Preamp dB	Level dBm	Limit dBm	Over limit	Remark	
1	96.76	-79.21	25.79	1.84	30.66	-82.24	-13.00	-69.24	Peak	
2	773.13	-75.07	29.21	5.67	29.49	-69.68	-13.00	-56.68	Peak	
3	4014.29	-66.65	41.60	5.59	36.99	-56.45	-13.00	-43.45	Peak	
4	5204.40	-69.00	43.92	6.31	35.50	-54.27	-13.00	-41.27	Peak	
5	7394.88	-69.46	48.59	7.78	34.45	-47.54	-13.00	-34.54	Peak	
6	10805.68	-68.60	52.61	9.91	35.96	-42.04	-13.00	-29.04	Peak	

Test channel:		4233			Polarization:		Horizontal		
Mark	Frequency MHz	Reading dBm	Antenna dB	Cable dB	Preamp dB	Level dBm	Limit dBm	Over limit	Remark
1	41.75	-80.24	26.96	1.18	30.58	-82.68	-13.00	-69.68	Peak
2	767.71	-75.70	29.39	5.64	29.46	-70.13	-13.00	-57.13	Peak
3	3824.76	-66.51	42.07	5.32	37.03	-56.15	-13.00	-43.15	Peak
4	5204.40	-69.01	43.95	6.31	35.50	-54.25	-13.00	-41.25	Peak
5	8042.90	-70.34	47.97	8.19	33.75	-47.93	-13.00	-34.93	Peak
6	10916.26	-69.75	52.71	9.96	35.92	-43.00	-13.00	-30.00	Peak
Test channel:		4233			Polarization:		Vertical		
Mark	Frequency MHz	Reading dBm	Antenna dB	Cable dB	Preamp dB	Level dBm	Limit dBm	Over limit	Remark
1	97.78	-79.97	25.78	1.85	30.65	-82.99	-13.00	-69.99	Peak
2	773.13	-75.45	29.21	5.67	29.49	-70.06	-13.00	-57.06	Peak
3	3543.55	-65.72	41.78	5.18	37.42	-56.18	-13.00	-43.18	Peak
4	4700.57	-68.73	43.57	5.88	36.00	-55.28	-13.00	-42.28	Peak
5	7860.74	-70.16	48.27	7.90	33.74	-47.73	-13.00	-34.73	Peak
6	10860.83	-69.36	52.66	9.93	35.94	-42.71	-13.00	-29.71	Peak

6. TEST SETUP PHOTOS OF THE EUT

Refer to the test report No.: CHTEW23100032

7. EXTERNAL AND INTERNAL PHOTOS OF THE EUT

Refer to the test report No.: CHTEW23100032

8. APPENDIX REPORT