

H158V-S

WIFI Module V3.0 模组规格书

WIFI Module V3.0 Module Datasheet



H158V-S 模组规格书

H158A-S Module Datasheet

办公室: 广东省深圳市宝安区航城大道骏翔 U8 智造 U6 栋 6 楼

工厂: 湖南省长沙市浏阳经济技术开发区利通路 8 号

电话: +86-755-2955-8186

网址: www.fn-link.com

Office: 6 Floor, Building U6, Junxiang U8 Park,
Hangcheng Avenue, Bao'an District,
Shenzhen City, CHINA

Factory: No.8, Litong Road, Liuyang Economic & Technical
Development Zone, Changsha, Hunan, CHINA

TEL: +86-755-2955-8186

Website: www.fn-link.com

客户承认 : _____ 公司

_____ 标题

_____ 签名

_____ 日期

_____ 欧智通

修订履历

Revision History

版本 Version	日期 Date	修改记录 Revision content	编辑 Draft	核准 Approved
1.0	2021/3/24	初版发行 New version	Lxy	SZS
1.1	2021/4/22	增加英文说明 Added EN version	Lxy	SZS
1.2	2021/6/10	增加模组天线应用注意事项 Added antenna area clearance description	Lxy	Lgp

目录 Contents

1 概述 Overview	1
1.1 简介 Introduction.....	1
1.2 特性 Features.....	1
1.3 方框图 Block Diagram.....	1
1.4 通用规格 General Specification.....	2
1.5 推荐工作条件 Recommended Operating Rating.....	2
1.6 电流功耗 Current informations.....	3
※1.7 EEPROM information.....	3
2 射频规格 WiFi Specification	3
2.1 Wi-Fi 射频规格 2.4G band Specification.....	3
3 引脚定义 Pin Assignments	5
3.1 引脚示意图 Pin Outline.....	5
3.2 引脚定义 Pin Definition.....	5
4 尺寸 Dimensions	6
4.1 产品图例 Module Picture.....	6
4.2 丝印信息 Marking Description.....	7
4.3 模组尺寸 Physical Dimensions.....	7
4.4 推荐封装尺寸 Layout Reference.....	8
6 时序要求 Host Interface Timing Diagram	9
6.1 SDIO 引脚概述 SDIO Pin Description.....	9
6.2 默认模式时序 SDIO Default Mode Timing Diagram.....	10
6.3 SDIO 上电时序 SDIO Power-on sequence.....	10
7 参考电路 Reference Design	13
8 订购信息 Ordering Information	15
9 关键器件列表 Key Material List	15
10 环境要求 Environmental Requirements	15
10.1 推荐回流曲线 Recommended Reflow Profile.....	15
10.2 使用说明 The notice before installed.....	16
11 包装 Package	17
11.1 编带 Reel.....	17
11.2 包装详情 Packaging Detail.....	18
12.3 湿敏特性 Moisture sensitivity.....	19

1 概述 Overview

1.1 简介 Introduction

H158V-S 是一款具有高集成度，优越性能的无线模组，支持 SDIO2.0 协议，基于南方硅谷 SV6158 方案，自带 PCB 板载天线。支持 802.11b/g/n 标准。

H158V-S is an excellent performance WLAN SDIO2.0 network interface device. Based on iCOMM chipset SV6158. support 802.11b/g/n standard. Module integrated PCB printed antenna.

1.2 特性 Features

- 工作在 2.4GHz 频段
Operate at ISM 2.4GHz frequency bands
- 单发单收支持最大速率 150Mbps
Wi-Fi 1 T 1 R allow data rates supporting up to 150 Mbps PHY rates
- SDIO 时钟最高支持 50Mhz
SDIO clock up to 50Mhz
- 模组尺寸 23x21mm
Module size is 23x21mm
- 模组自带 PCB 板载天线
Module have integrated PCB printed antenna

1.3 方框图 Block Diagram

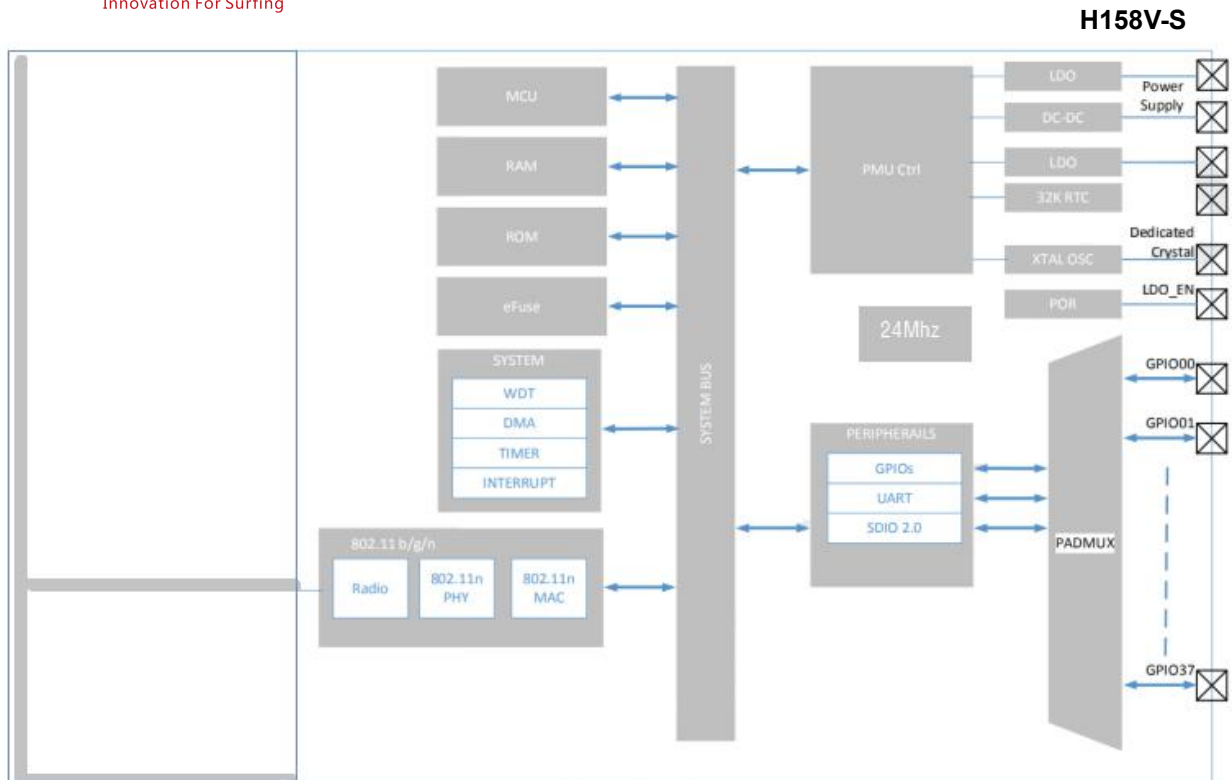

1.4 通用规格 General Specification

型号 Model	H158V-S
描述 Description	Wi-Fi module
尺寸 Dimension	长 x 宽 x 高: 23 x 21 x 2.4 mm
Wi-Fi 接口 Interface	SDIO V2.0
工作温度 Operating temperature	-10°C to 70°C
存储温度 Storage temperature	-40°C to +85°C
RoHS	符合欧盟 RoHS 指令 All hardware components are fully compliant with EU RoHS directive

1.5 推荐工作条件 Recommended Operating Rating

	最小值 Min.	典型值 Typ.	最大值 Max.	单位 Unit
工作温度 Operating Temperature	-10	25	70	° C

VBAT	3.0	3.3	3.6	V
VDDIO	1.7	1.8 or 3.3	3.6	V

1.6 电流功耗 Current informations

Vcc=3.3V, Ta=25° C, unit: mA	
电流 Current	平均值 Average
11b 11Mbps TX mode	186.6
11g 54Mbps TX mode	158
11n HT20 MCS7 TX mode	159.4
11n HT40 MCS7 TX mode	161
RX mode	35.7
Saving mode DTIM3	0.21
BLE TX	90.3
BLE RX	33

※1.7 EEPROM information

NA

2 射频规格 WiFi Specification

2.1 Wi-Fi 射频规格 2.4G band Specification

功能 Feature	描述 Description
无线标准 WLAN Standard	IEEE 802.11 b/g/n Wi-Fi compliant
频率范围 Frequency Range	2.400 GHz ~ 2.4835 GHz (2.4 GHz ISM Band)
支持信道 Number of Channel	2.4GHz: Ch1 ~ Ch14
频谱模板 Spectrum Mask	符合 IEEE 标准 compliant with IEEE Standard
频率误差 Freq. Tolerance	±20PPM
输出功率 Output Power	11b /11M : 17± 2 dBm EVM ≤ -9dB
	11g /54M : 15± 2 dBm EVM ≤ -26dB
	11n /MCS7: 15± 2 dBm EVM ≤ -28dB

	其他速率对应功率由驱动配置 Other rate power setting by driver	
接收灵敏度 Sensitivity	典型值 Typical value	标准值 Standard value
11b,20MHz@8% PER	- 1M @ -94 dBm	≤-83
	- 2M @ -92 dBm	≤-80
	- 5.5M @ -91 dBm	≤-79
	- 11M @ -89 dBm	≤-76
11g,20MHz@10% PER	- 6M @ -89 dBm	≤-85
	- 9M @ -88 dBm	≤-84
	- 12M @ -87 dBm	≤-82
	- 18M @ -84 dBm	≤-80
	- 24M @ -81 dBm	≤-77
	- 36M @ -78 dBm	≤-73
	- 48M @ -73 dBm	≤-69
	- 54M @ -71 dBm	≤-68
11n,20MHz@10% PER	- MCS0 @ -89 dBm	≤-85
	- MCS1 @ -86 dBm	≤-82
	- MCS2 @ -84 dBm	≤-80
	- MCS3 @ -80 dBm	≤-77
	- MCS4 @ -77 dBm	≤-73
	- MCS5 @ -72 dBm	≤-69
	- MCS6 @ -71 dBm	≤-68
	- MCS7 @ -70 dBm	≤-67
11n ,40MHz@10% PER	- MCS0 @ -89 dBm	≤-82
	- MCS1 @ -85 dBm	≤-79
	- MCS2 @ -83 dBm	≤-77
	- MCS3 @ -80 dBm	≤-74
	- MCS4 @ -76 dBm	≤-70
	- MCS5 @ -71 dBm	≤-66
	- MCS6 @ -70 dBm	≤-65
	- MCS7 @ -68 dBm	≤-64
最大输入电平 Maximum Input Level	802.11b : -10 dBm 802.11g/n : -20 dBm	
天线 Antenna reference	增益 ≤2 dBi antennas with 0~2 dBi peak gain	

3 引脚定义 Pin Assignments

3.1 引脚示意图 Pin Outline

<顶视图>
<Top view>

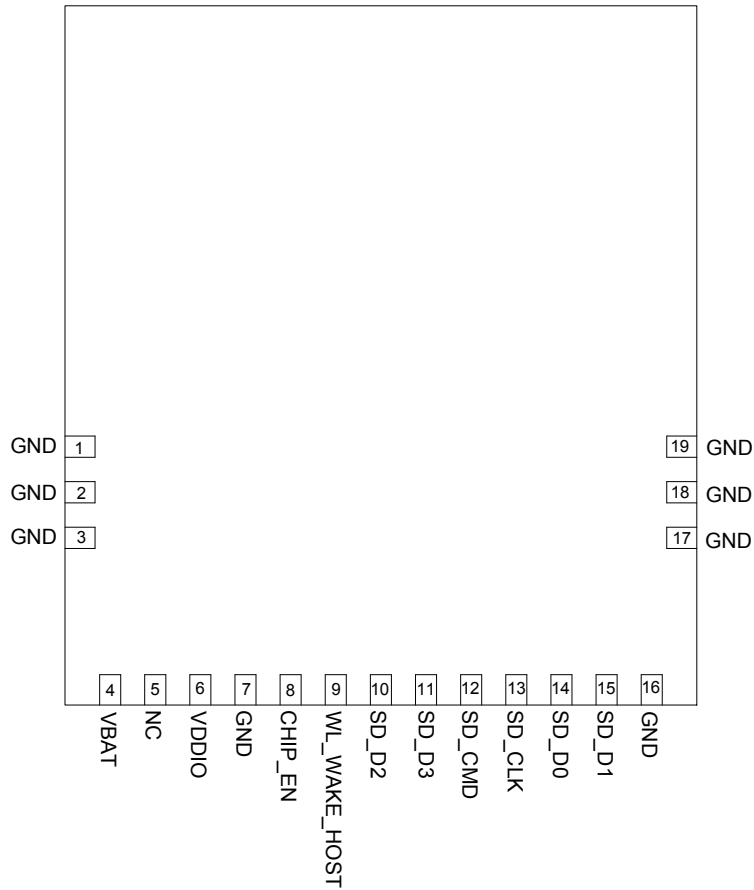

3.2 引脚定义 Pin Definition

序号 PIN#	名称 NAME	类型 TYP	描述 Description	电平 Voltage
1	GND		GND connection	
2	GND		GND connection	
3	GND		GND connection	
4	VBAT	P	DC input 3.3V	3.3V
5	NC		No connection	

6	VDDIO	P	DC input 1.8V or 3.3V	1.8V or 3.3V
7	GND		GND connection	
8	CHIP_EN	I	Enable module, default internal pull high with 10K	VDDIO
9	WL_WAKE_HOST	I/O	Module wake up host	VDDIO
10	SD_D2	I/O	SDIO Data line 2	VDDIO
11	SD_D3	I/O	SDIO Data line 3	VDDIO
12	SD_CMD	I/O	SDIO Command	VDDIO
13	SD_CLK	I	SDIO Clock	VDDIO
14	SD_D0	I/O	SDIO Data line 0	VDDIO
15	SD_D1	I/O	SDIO Data line 1	VDDIO
16	GND		GND connection	
17	GND		GND connection	
18	GND		GND connection	
19	GND		GND connection	

P:POWER I:INPUT O:OUTPUT

4 尺寸 Dimensions

4.1 产品图例 Module Picture

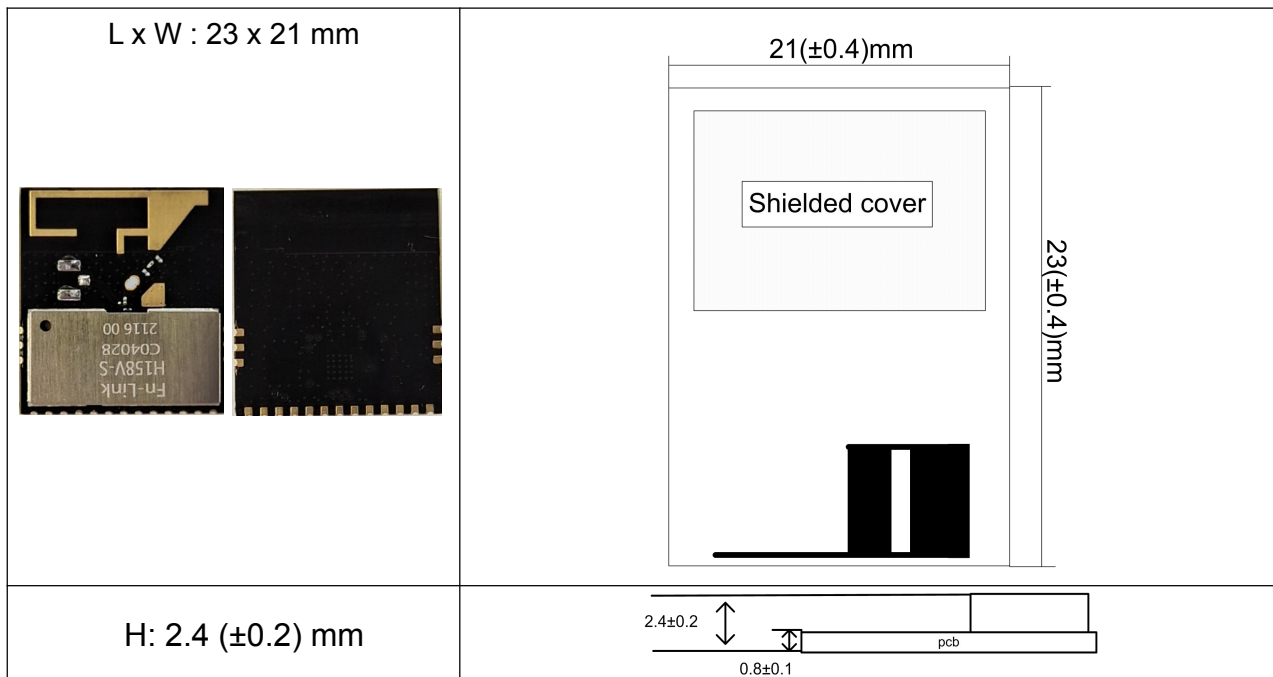

Weight	1.53g
--------	-------

4.2 丝印信息 Marking Description

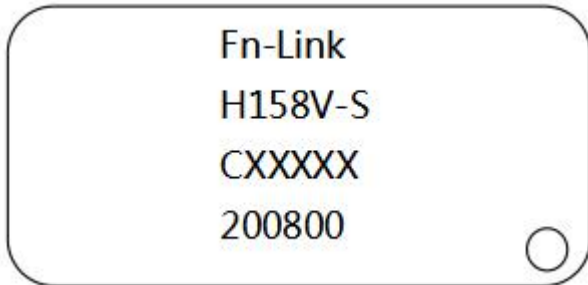

4.3 模组尺寸 Physical Dimensions

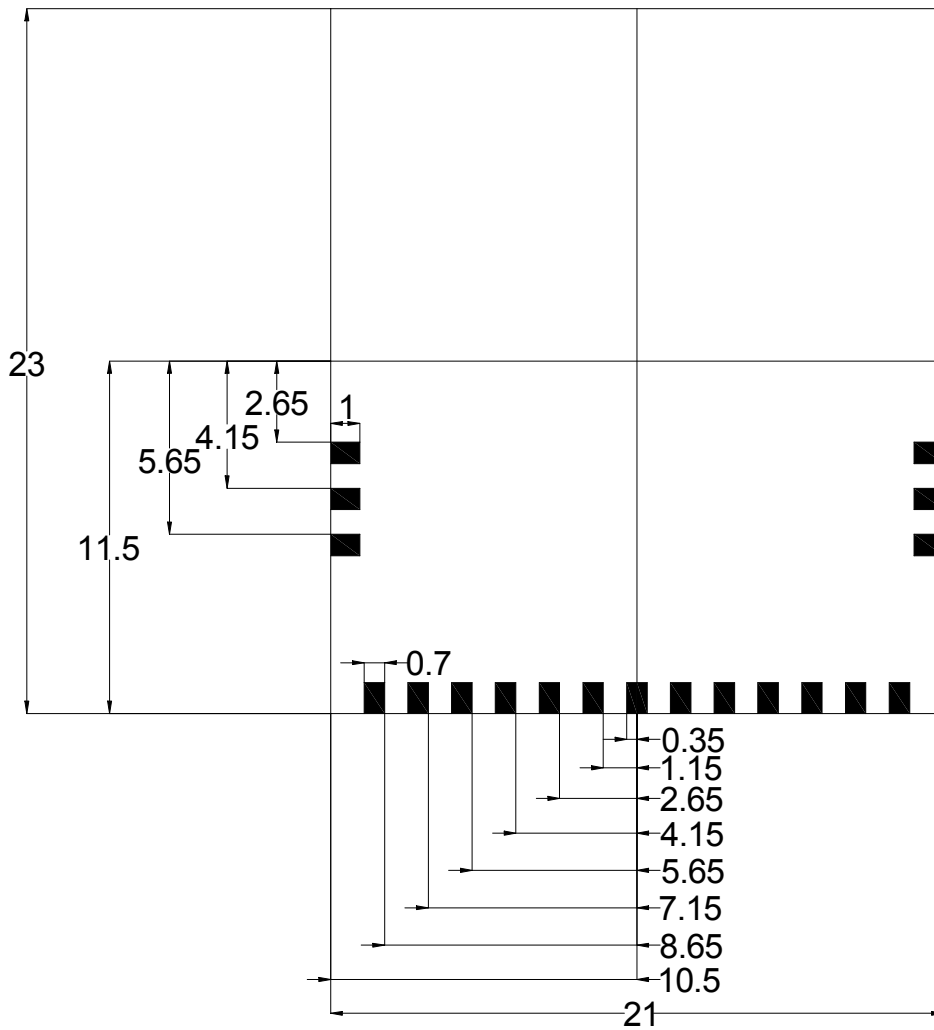

4.4 推荐封装尺寸 Layout Reference

(unit: mm)

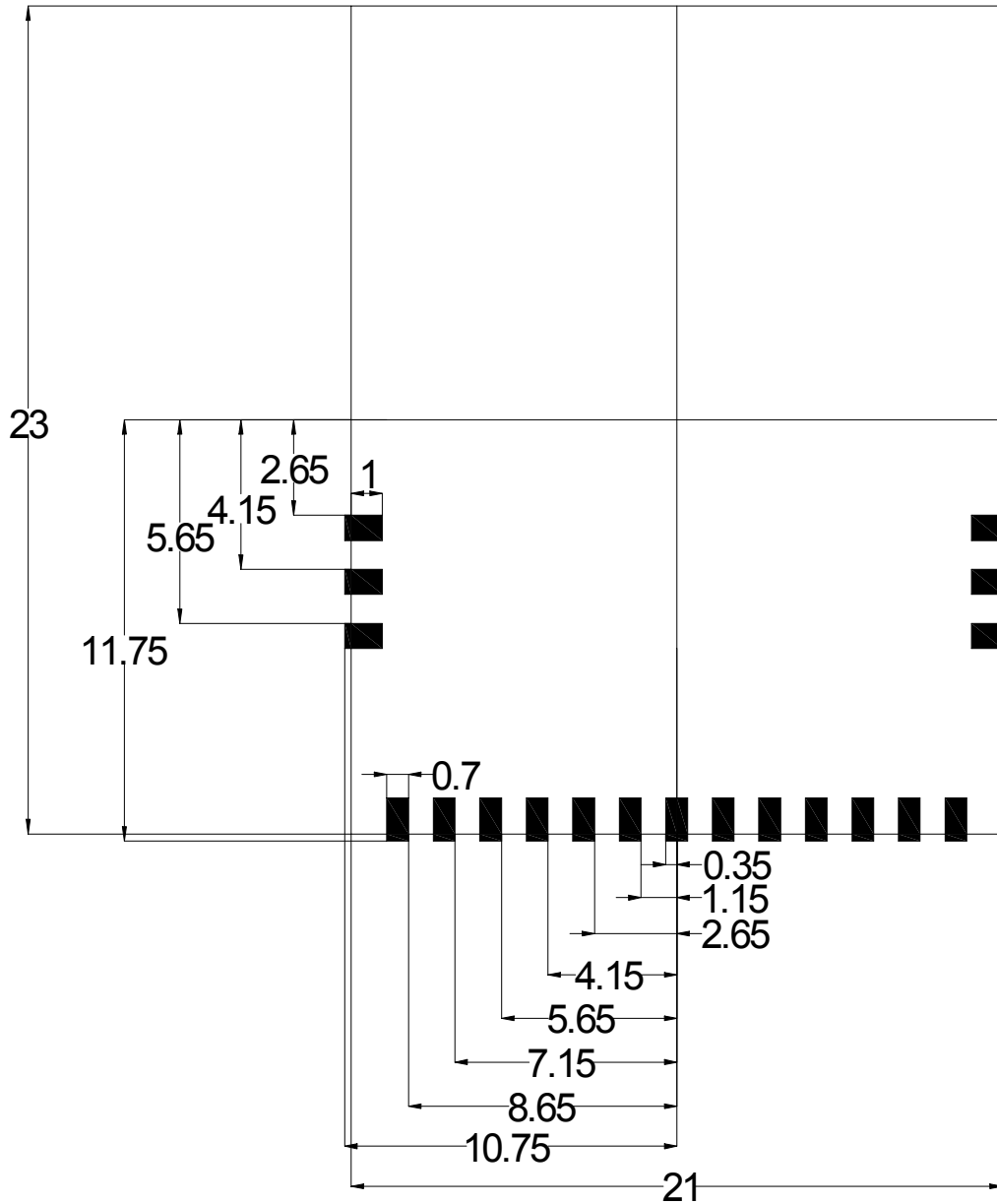

6 时序要求 Host Interface Timing Diagram

6.1 SDIO 引脚概述 SDIO Pin Description

模组支持 SDIO V2.0 版本，1.8V 和 3.3V 电平。

Module with SDIO V2.0 interface, support 1.8V and 3.3V voltage level

SDIO 4-Bit Mode	
DATA0	Data Line 0
DATA1	Data Line 1
DATA2	Data Line 2
DATA3	Data Line 3
CLK	Clock
CMD	Command Line

6.2 默认模式时序 SDIO Default Mode Timing Diagram

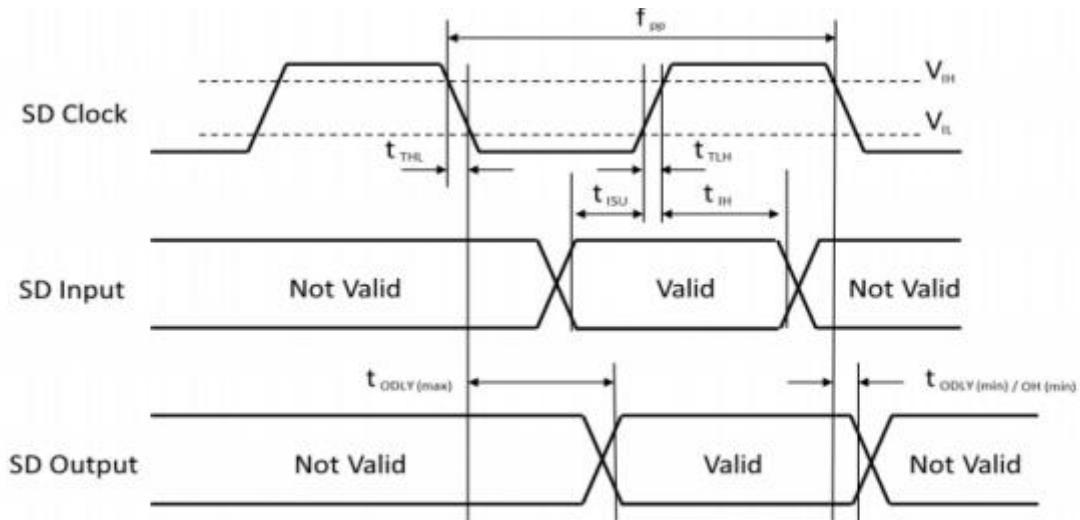

SDIO TIMING WAVEFORM

SDIO version 2.0 Timing Specifications

Symbol	Parameter	Min.	Typ.	Max.	Unit
Clock CLK (All values are referred to min(V_{IH}) and max(V_{IL}).					
f _{PP}	Clock frequency Data Transfer Mode	0		50	MHz
t _{TLH}	Clock rise time			3	ns
t _{THL}	Clock fall time			3	ns
Inputs CMD, DAT (reference to CLK)					
t _{ISU}	Input set-up time	6			ns
t _{IH}	Input hold time	2			ns
Outputs CMD, DAT (reference to CLK)					
t _{ODLY}	Output Delay time during Data Transfer Mode			14	ns
t _{OH}	Output Hold time	2.5			Ns

6.3 SDIO 上电时序 SDIO Power-on sequence

图 4 显示从上电到驱动加载上电顺序，包括由 LDO_EN 引发的初始化设备上电复位。LDO_EN 输入电平必须保持与 VDDIO 电压电平相同。在初始通电后，LDO_EN 信号可以保持在低电平以关闭模组，或者脉冲低电平以引导随后的复位。在 LDO_EN 被拉高并且主机启动模组的上电时序如下：

1. 在 1.3 毫秒内，将完成内部上电复位（POR）。主机可以下载 DPLL 设置的固件代码，如果晶体不是默认设置 26MHz。内部运行时钟就是晶体频率。
2. 经过 100us 的 DPLL 设置时间后，主机可以将内部时钟设置为全速，完成所有固件代

码的下载。

Figure 4 shows the power-on sequence of the module from power-up to firmware download, including the initial device power-on reset evoked by LDO_EN signal. The LDO_EN input level must be kept the same as VDDIO voltage level. After initial power-on, the LDO_EN signal can be held low to turn off the SV6158 or pulsed low to induce a subsequent reset. After LDO_EN is assert and host starts the power-on sequence of the SV6158. From that point, the typical SV6158 power-on sequence is shown below:

1. Within 1.3 millisecond, the internal power-on reset (POR) will be done. And host could download firmware code of DPLL setting if the crystal is not default setting, 26MHz. The internal running clock is crystal frequency.
2. After 100us of DPLL settling time, host could set internal clock to full speed and finish all the downloading of firmware code.

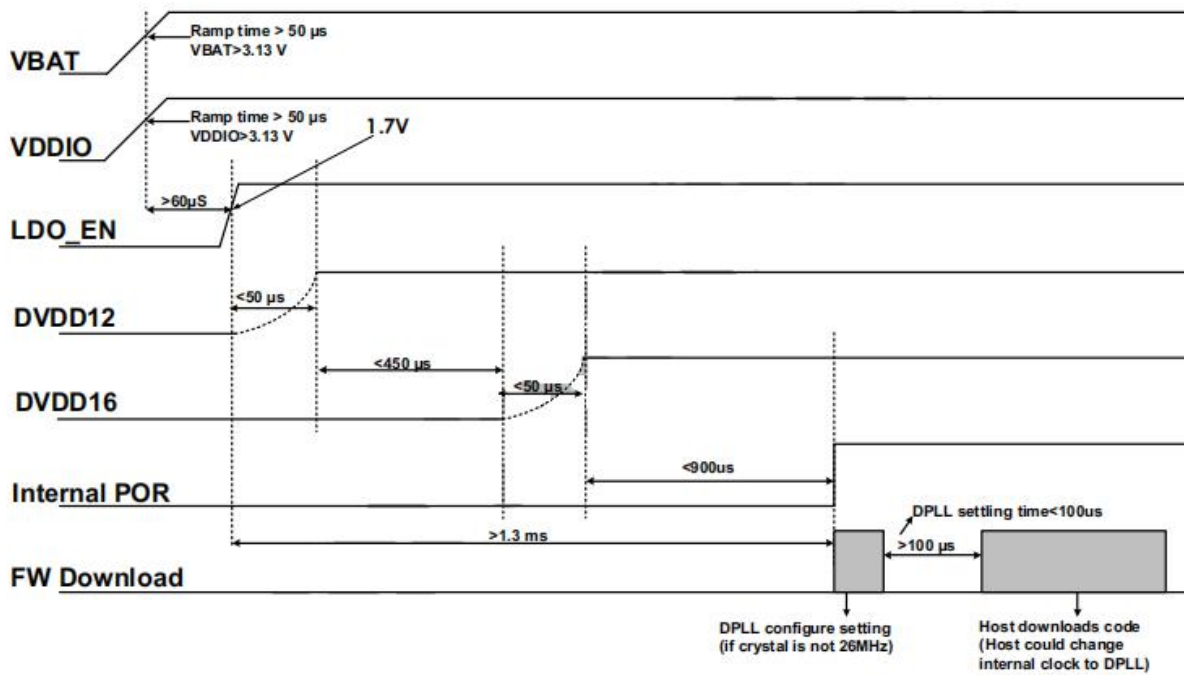

Figure 4 : Power-on sequence

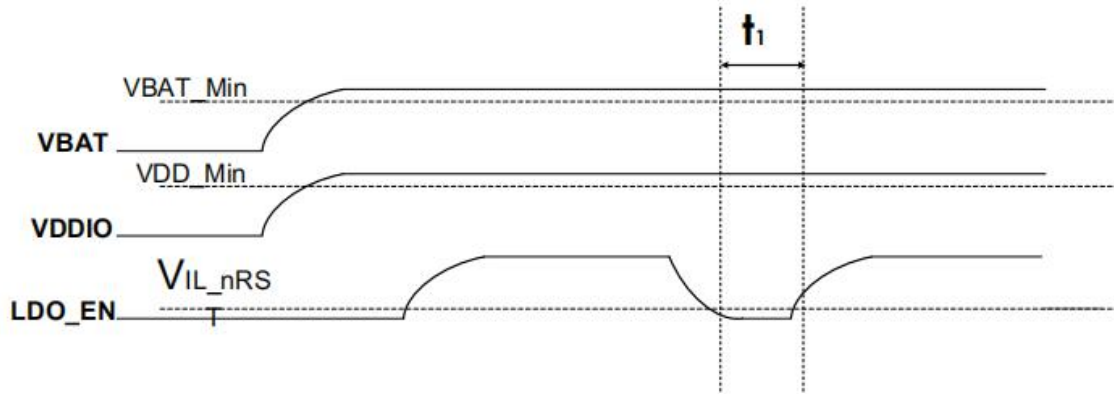

Figure 5 : Reset Timing

Table 2 : Reset Timing Parameters

Parameters	Description	Min.	Unit
t1	Duration of LDO_EN signal level < VIL_nRST to reset the chip	30	us

模组 LDO_EN 引脚可用于完全复位整个芯片。此信号复位解除后，芯片处于关闭模式，等待主机通信。在此之前，MAC、BB 和 SOC 断电，所有模块保持复位。一旦主机启动了通信，芯片就会打开时钟晶体，然后再打开 DPLL。待时钟稳定运行后，所有模块的复位完成。

The SV6158 LDO_EN pin can be used to completely reset the entire chip. After this signal has been de-asserted, the SV6158 is in off mode waits for host communication. Until then, the MAC, BB, and SOC blocks are powered off and all modules are held in reset. Once the host has initiated communication, the SV615XP turns on its crystal and later on DPLL. After all clocks are stable and running, the resets to all blocks are automatically de-asserted.

7 参考电路 Reference Design

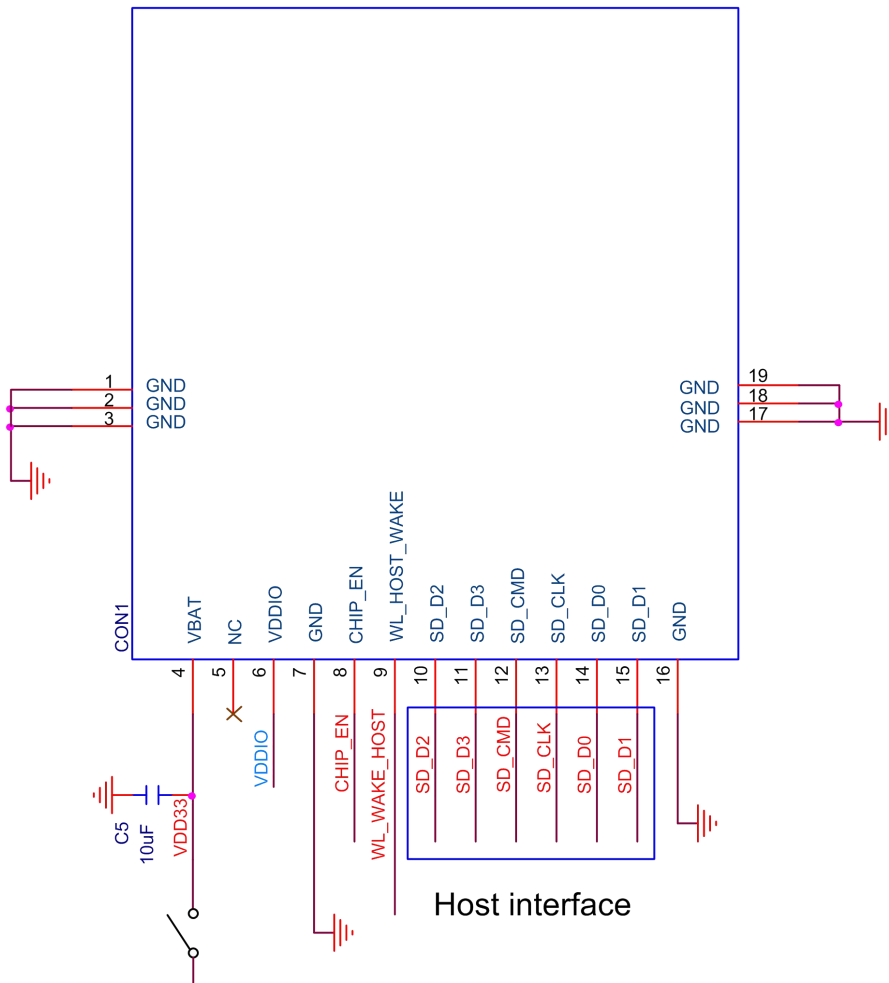

备注 Note:

天线区域保持尽可能多净空区间，至少需以下图为例做设计。

Antenna keep as more as possible clean space.

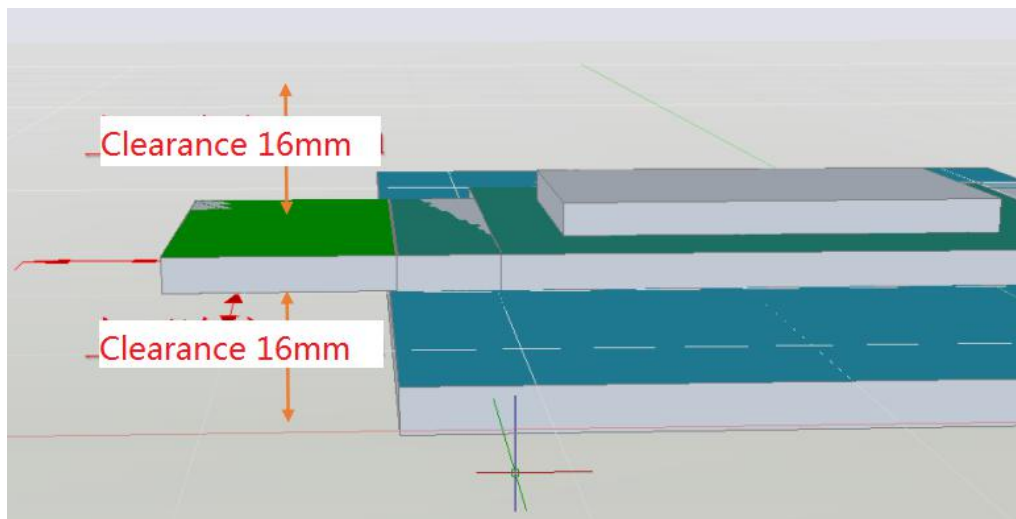
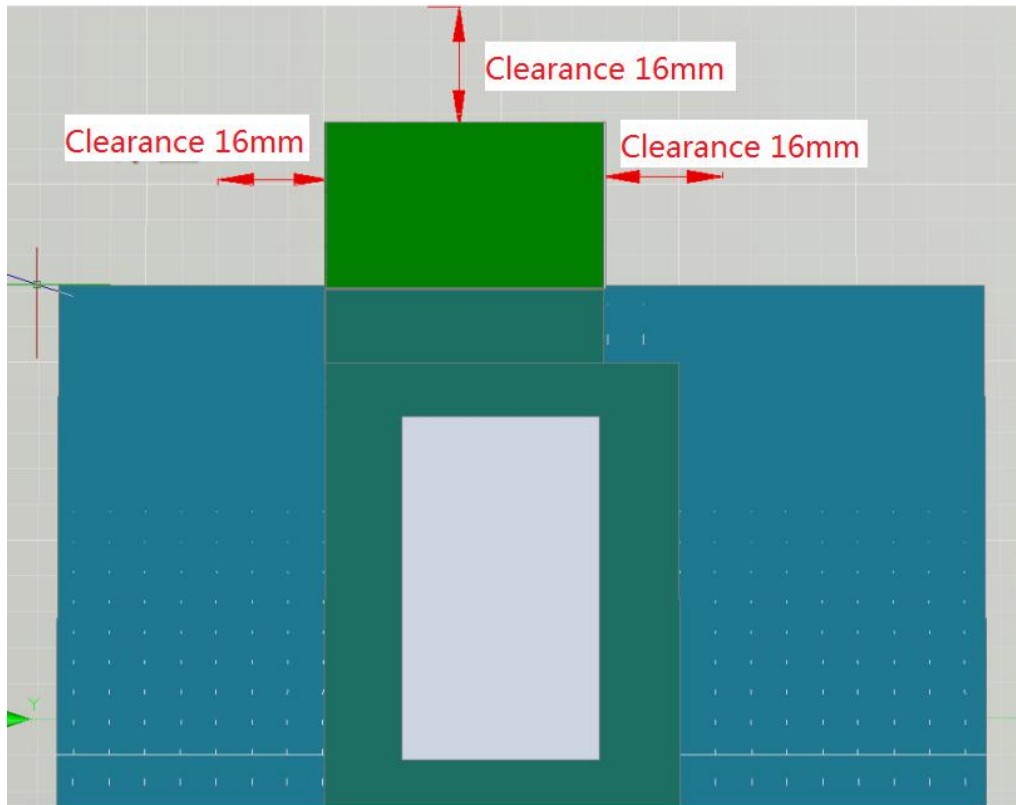

8 订购信息 Ordering Information

Part No.	Description
FGH158VSXX-00	SV6158P,b/g/n,WiFi,1T1R,SDIO,23x21mm,带天线,带屏蔽盖

9 关键器件列表 Key Material List

名称	描述	厂商
Crystal	3225,24MHZ,CL=12pF,10ppm	ECEC,HOSONIC,TKD,JWT
PCB	H158V-S-V1.0,black,4L,23X21X0.8mm	XY-PCB,LX-PCB,SL-PCB,Sunlord
Chipset	SV6158,11b/g/n,SDIOWiFi,4x4mm,QFN32	iCOMMSEMI
Inductor	0603 4.7uH,20%,400mA	Sunlord,cenke,ceaiya,Microgate
Shielding	H158V-S-V1.0 shielding	Suntech,Jlitong
TVS	0201 ESD	WAY-ON,Murata,Sunlord

10 环境要求 Environmental Requirements

10.1 推荐回流曲线 Recommended Reflow Profile

Referred to IPC/JEDEC standard.

Peak Temperature : <250°C

Number of Times : ≤2 times

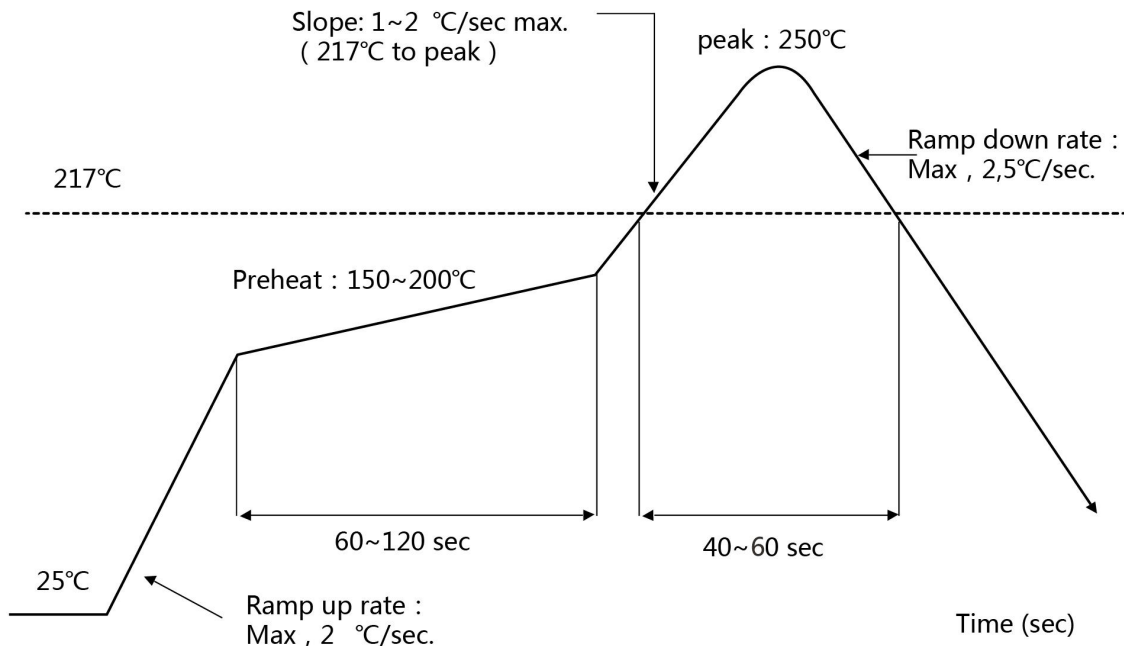

10.2 使用说明 The notice before installed

贴装 Wi-Fi 模块注意：

- 1 使用 WIFI 模块，请确保静电防护措施。
- 2.回流焊温度应综合根据客户产品而定，如客户主板的温度设定为 $250+5^{\circ}\text{C}$ 。

关于模块的包装、存放和使用注意事项如下：

1 卷装模块及真空包装贮存寿命：1)。保质期：8 个月，储存环境条件：温度： $<40^{\circ}\text{C}$ ，相对湿度： $<90\%r.h$ 。

2 组件真空包装一旦打开，组装时限：

卡片：

1)检查湿度显示值应小于 30%（蓝色），如：30%~40%（粉色），或大于 40%（红色）的模块已被吸湿。

2.) 工厂环境温湿度控制： $\leq 30^{\circ}\text{C}$ ，相对湿度 $\leq 60\%$ 。。

3). 车间一经开放，就可以保存 168 小时的生命。

3. 一旦打开，如 168 小时内未用完：

1). 必须再次拆卸模块，以去除模块的吸湿性。

2). 烘烤温度： 125°C ，8 小时。

3). 烘烤后，放入适量干燥剂密封包装。

Wi-Fi module installed note:

1. Take and use the WIFI module, please insure the electrostatic protective measures.
2. Reflow soldering temperature should be according to the customer the main size of the products, such as the temperature set at $250 + 5 \text{ }^{\circ}\text{C}$ for the MID motherboard.

About the module packaging, storage and use of matters needing attention are as follows:

1. The module of the reel and storage life of vacuum packing: 1). Shelf life: 8 months, storage environment conditions: temperature in: $< 40 \text{ }^{\circ}\text{C}$, relative humidity: $< 90\%$ r.h.
2. The module vacuum packing once opened, time limit of the assembly:
Card:1) check the humidity display value should be less than 30% (in blue), such as: 30% ~ 40% (pink), or greater than 40% (red) the module have been moisture absorption.
2.) factory environmental temperature humidity control: $\leq -30 \text{ }^{\circ}\text{C}$, $\leq 60\%$ r.h..
3). Once opened, the workshop the preservation of life for 168 hours.
3. Once opened, such as when not used up within 168 hours:
 - 1). The module must be again to remove the module moisture absorption.
 - 2). The baking temperature: $125 \text{ }^{\circ}\text{C}$, 8 hours.
 - 3). After baking, put the right amount of desiccant to seal packages.

11 包装 Package

11.1 编带 Reel

A roll of 350pcs

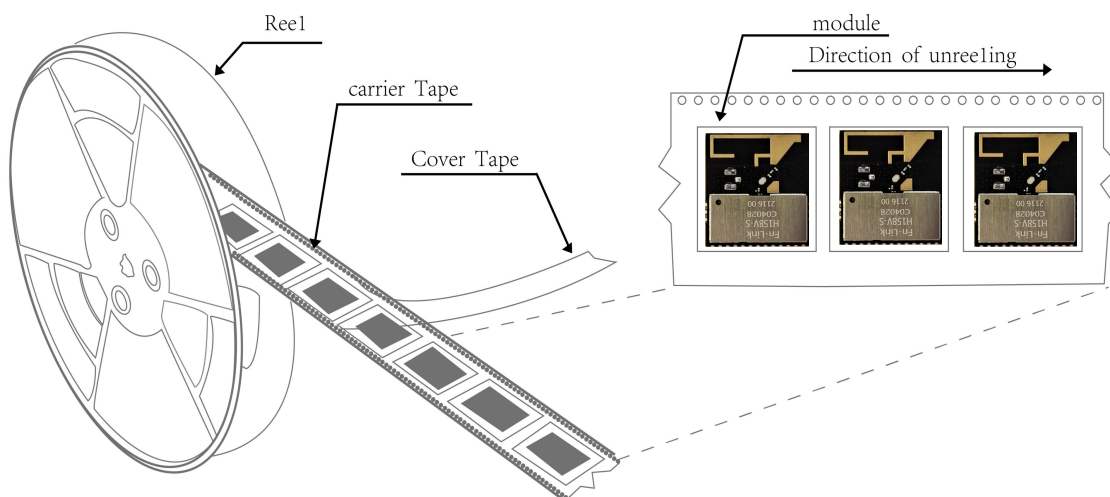

11.2 包装详情 Packaging Detail

编带和胶盘包装 the take-up package



Using self-adhesive tape

Size of black tape:24mm*32.6m the cover tape :21.3mm*32.6m

Color of plastic disc:blue

A roll of 350pcs



NY bag size:420mm*450mm



size : 335*335*55mm



The packing case size:335*255*360mm

12.3 湿敏特性 Moisture sensitivity

根据 IPC/JEDEC J-STD-020 标准，模块为 3 级湿度敏感设备，请小心使用这种组件的所有相关要求。

此外，客户必须注意以下情况：

- a) 密封袋中的计算保质期：在<40° C 和<90%相对湿度（RH）下 12 个月。
- b) 生产过程中的环境条件：根据 IPC/JEDEC J-STD-033A 第 5 段，30° C/60%RH。
- c) 如果条件允许，打开密封袋和回流过程之间的最长时间必须为 168 小时
- b) 遵守“IPC/JEDEC J-STD-033A 第 5.2 段”
- d) 如果不遵守条件 b) 或 c) ，则需要烘烤
- e) 如果袋内湿度指示器指示相对湿度大于等于 10%，则需要烘烤

The Modules is a Moisture Sensitive Device level 3, in according with standard IPC/JEDEC J-STD-020, take care

all the relatives requirements for using this kind of components.

Moreover, the customer has to take care of the following conditions:

- a) Calculated shelf life in sealed bag: 12 months at <40°C and <90% relative humidity (RH).
- b) Environmental condition during the production: 30°C / 60% RH according to IPC/JEDEC J-STD-033A paragraph 5.
- c) The maximum time between the opening of the sealed bag and the reflow process must be 168 hours if condition
- b) “IPC/JEDEC J-STD-033A paragraph 5.2” is respected
- d) Baking is required if conditions b) or c) are not respected
- e) Baking is required if the humidity indicator inside the bag indicates 10% RH or more

FCC MODULAR APPROVAL INFORMATION EXAMPLES for Manual

This device complies with Part 15 of the FCC Rules. Operation is subject to the following two conditions:

- (1) This device may not cause harmful interference.
- (2) This device must accept any interference received, including interference that may cause undesired operation.

CAUTION: Changes or modifications not expressly approved by the party responsible for compliance could void the user's authority to operate the equipment.

NOTE: This equipment has been tested and found to comply with the limits for a Class B digital device, pursuant to Part 15 of the FCC Rules. These limits are designed to provide reasonable protection against harmful interference in a residential installation. This equipment generates uses and can radiate radio frequency energy and, if not installed and used in accordance with the instructions, may cause harmful interference to radio communications. However, there is no guarantee that interference will not occur in a particular installation. If this equipment does cause harmful interference to radio or television reception, which can be determined by turning the equipment off and on, the user is encouraged to try to correct the interference by one or more of the following measures:

- Reorient or relocate the receiving antenna.
- Increase the separation between the equipment and receiver.
- Connect the equipment into an outlet on a circuit different from that to which the receiver is connected.
- Consult the dealer or an experienced radio/TV technician for help.

FCC Radiation Exposure Statement:

This equipment complies with FCC radiation exposure limits set forth for an uncontrolled environment. This equipment should be installed and operated with minimum distance 20cm between the radiator & your body.

OEM INTEGRATION INSTRUCTIONS:

This device is intended only for OEM integrators under the following conditions:

The module must be installed in the host equipment such that 20 cm is maintained between the antenna and users, and the transmitter module may not be co-located with any other transmitter or antenna. The module shall be only used with the internal on-board antenna that has been originally tested and certified with this module. External antennas are not supported. As long as these 3 conditions above are met, further transmitter test will not be required.

However, the OEM integrator is still responsible for testing their end-product for any additional compliance requirements required with this module installed (for example, digital device emissions, PC peripheral requirements, etc.). The end-product may need Verification testing, Declaration of Conformity testing, a Permissive Class II Change or new Certification. Please involve a FCC certification specialist in order to determine what will be exactly applicable for the end-product.

Validity of using the module certification:

In the event that these conditions cannot be met (for example certain laptop configurations or co-location with another transmitter), then the FCC authorization for this module in combination with the host equipment is no longer considered valid and the FCC ID of the module cannot be used on the final product. In these circumstances, the OEM integrator will be responsible for re-evaluating the end product (including the transmitter) and obtaining a separate FCC authorization. In such cases, please involve a FCC certification specialist in order to determine if a Permissive Class II Change or new Certification is required.

Upgrade Firmware:

The software provided for firmware upgrade will not be capable to affect any RF parameters as certified for the FCC for this module, in order to prevent compliance issues.

End product labeling:

This transmitter module is authorized only for use in device where the antenna may be installed such that 20 cm may be maintained between the antenna and users. The final end product must be labeled in a visible area with the following: "Contains FCC ID: 2ASV9-H158VS".

Information that must be placed in the end user manual:

The OEM integrator has to be aware not to provide information to the end user regarding how to install or remove this RF module in the user's manual of the end product which integrates this module. The end user manual shall include all required regulatory information/warning as show in this manual.

FCC MODULAR APPROVAL INFORMATION EXAMPLES for Manual

This device complies with Part 15 of the FCC Rules. Operation is subject to the following two conditions:

- (1) This device may not cause harmful interference.
- (2) This device must accept any interference received, including interference that may cause undesired operation.

CAUTION: Changes or modifications not expressly approved by the party responsible for compliance could void the user's authority to operate the equipment.

NOTE: This equipment has been tested and found to comply with the limits for a Class B digital device, pursuant to Part 15 of the FCC Rules. These limits are designed to provide reasonable protection against harmful interference in a residential installation. This equipment generates uses and can radiate radio frequency energy and, if not installed and used in accordance with the instructions, may cause harmful interference to radio communications. However, there is no guarantee that interference will not occur in a particular installation. If this equipment does cause harmful interference to radio or television reception, which can be determined by turning the equipment off and on, the user is encouraged to try to correct the interference by one or more of the following measures:

- Reorient or relocate the receiving antenna.
- Increase the separation between the equipment and receiver.
- Connect the equipment into an outlet on a circuit different from that to which the receiver is connected.
- Consult the dealer or an experienced radio/TV technician for help.

WARNING

Changes or modifications not expressly approved by the manufacturer could void the user's authority to operate the equipment.

“CAUTION : Exposure to Radio Frequency Radiation.

Antenna shall be mounted in such a manner to minimize the potential for human contact during normal operation. The antenna should not be contacted during operation to avoid the possibility of exceeding the FCC radio frequency exposure limit.

IC Information

This device complies with Industry Canada license-exempt RSS standard(s). Operation is subject to the following two conditions:

- (1) this device may not cause interference, and
- (2) this device must accept any interference, including interference that may cause undesired operation of the device.

Cet appareil est conforme avec Industrie Canada exempts de licence standard RSS (s). L'opération est soumise aux deux conditions suivantes:

- (1) cet appareil ne peut causer d'interférences, et*
- (2) cet appareil doit accepter toute interférence, y compris les interférences qui peuvent causer un mauvais fonctionnement de l'appareil.*

The end product must be labeled to display the Industry Canada certification number of the module.

Contains transmitter module IC: 24909-H158VS

Le dispositif d'accueil doivent être étiquetés pour afficher le numéro de certification d'Industrie Canada du module.

Contient module émetteur IC: 24909-H158VS

Information for OEM Integrator

This device is intended only for OEM integrators under the following conditions:

- 1) The antenna must be installed such that 20 cm is maintained between the antenna and users, and
- 2) The transmitter module may not be co-located with any other transmitter or antenna.

End product labelling

The label for end product must include

“Contains FCC ID: 2ASV9-H158VS, Contains IC: 24909-H158VS”.

“CAUTION: Exposure to Radio Frequency Radiation.

This equipment complies with FCC radiation exposure limits set forth for an uncontrolled environment. This equipment should be installed and operated with minimum distance of 20cm between the radiator and your body. This transmitter module is authorized only for use in device where the antenna may be installed such that 20 cm may be maintained between the antenna and users.”

Requirement per KDB996369 D03

2.2 List of applicable FCC rules

List the FCC rules that are applicable to the modular transmitter. These are the rules that specifically establish the bands of operation, the power, spurious emissions, and operating fundamental frequencies. DO NOT list compliance to unintentional-radiator rules (Part 15 Subpart B) since that is not a condition of a module grant that is extended to a host manufacturer. See also Section 2.10 below concerning the need to notify host manufacturers that further testing is required.³

Explanation: This module meets the requirements of FCC part 15C(15.247).

2.3 Summarize the specific operational use conditions

Describe use conditions that are applicable to the modular transmitter, including for example any limits on antennas, etc. For example, if point-to-point antennas are used that require reduction in power or compensation for cable loss, then this information must be in the instructions. If the use condition limitations extend to professional users, then instructions must state that this information also extends to the host manufacturer's instruction manual. In addition, certain information may also be needed, such as peak gain per frequency band and minimum gain.

Explanation: The EUT has a PCB Antenna, and the antenna use a permanently attached antenna which is not replaceable.

2.4 Limited module procedures

If a modular transmitter is approved as a "limited module," then the module manufacturer is responsible for approving the host environment that the limited module is used with. The manufacturer of a limited module must describe, both in the filing and in the installation instructions, the alternative means that the limited module manufacturer uses to verify that the host meets the necessary requirements to satisfy the module limiting conditions.

A limited module manufacturer has the flexibility to define its alternative method to address the conditions that limit the initial approval, such as: shielding, minimum signaling amplitude, buffered modulation/data inputs, or power supply regulation. The alternative method could include that the limited module manufacturer reviews detailed test data or host designs prior to giving the host manufacturer approval.

This limited module procedure is also applicable for RF exposure evaluation when it is necessary to demonstrate compliance in a specific host. The module manufacturer must state how control of the product into which the modular transmitter will be installed will be maintained such that full compliance of the product is always ensured. For additional hosts other than the specific host originally granted with a limited module, a Class II permissive change is required on the module grant to register the additional host as a specific host also approved with the module.

Explanation: The module is not a limited module.

2.5 Trace antenna designs

For a modular transmitter with trace antenna designs, see the guidance in Question 11 of KDB Publication 996369 D02 FAQ – Modules for Micro-Strip Antennas and traces. The integration information shall include for the TCB review the integration instructions for the following aspects:

layout of trace design, parts list (BOM), antenna, connectors, and isolation requirements.

- a) Information that includes permitted variances (e.g., trace boundary limits, thickness, length, width, shape(s), dielectric constant, and impedance as applicable for each type of antenna);
- b) Each design shall be considered a different type (e.g., antenna length in multiple(s) of frequency, the wavelength, and antenna shape (traces in phase) can affect antenna gain and must be considered);
- c) The parameters shall be provided in a manner permitting host manufacturers to design the printed circuit (PC) board layout;
- d) Appropriate parts by manufacturer and specifications;
- e) Test procedures for design verification; and
- f) Production test procedures for ensuring compliance.

The module grantee shall provide a notice that any deviation(s) from the defined parameters of the antenna trace, as described by the instructions, require that the host product manufacturer must notify the module grantee that they wish to change the antenna trace design. In this case, a Class II permissive change application is required to be filed by the grantee, or the host manufacturer can take responsibility through the change in FCC ID (new application) procedure followed by a Class II permissive change application.

Explanation: Yes, The module with trace antenna designs, and This manual has been shown the layout of trace design, antenna, connectors, and isolation requirements.

2.6 RF exposure considerations

It is essential for module grantees to clearly and explicitly state the RF exposure conditions that permit a host product manufacturer to use the module. Two types of instructions are required for RF exposure information: (1) to the host product manufacturer, to define the application conditions (mobile, portable – xx cm from a person's body); and (2) additional text needed for the host product manufacturer to provide to end users in their end-product manuals. If RF exposure statements and use conditions are not provided, then the host product manufacturer is required to take responsibility of the module through a change in FCC ID (new application).

Explanation: This module complies with FCC RF radiation exposure limits set forth for an uncontrolled environment, This equipment should be installed and operated with a minimum distance of 20 centimeters between the radiator and your body." This module is designed to comply with the FCC statement, FCC ID is: 2ASV9-H158VS.

2.7 Antennas

A list of antennas included in the application for certification must be provided in the instructions. For modular transmitters approved as limited modules, all applicable professional installer instructions must be included as part of the information to the host product manufacturer. The antenna list shall also identify the antenna types (monopole, PIFA, dipole, etc. (note that for example an “omni-directional antenna” is not considered to be a specific “antenna type”)).

For situations where the host product manufacturer is responsible for an external connector, for example with an RF pin and antenna trace design, the integration instructions shall inform the installer that unique antenna connector must be used on the Part 15 authorized transmitters used in the host product. The module manufacturers shall provide a list of acceptable unique connectors.

Explanation: The EUT has a PCB Antenna, and the antenna use a permanently attached antenna which is unique.

2.8 Label and compliance information

Grantees are responsible for the continued compliance of their modules to the FCC rules. This includes advising host product manufacturers that they need to provide a physical or e-label stating “Contains FCC ID” with their finished product. See Guidelines for Labeling and User Information for RF Devices – KDB Publication 784748.

Explanation:The host system using this module, should have label in a visible area indicated the following texts: “Contains FCC ID: 2ASV9-H158VS, Contains IC: 24909-H158VS”

2.9 Information on test modes and additional testing requirements

Additional guidance for testing host products is given in KDB Publication 996369 D04 Module Integration Guide. Test modes should take into consideration different operational conditions for a stand-alone modular transmitter in a host, as well as for multiple simultaneously transmitting modules or other transmitters in a host product.

The grantee should provide information on how to configure test modes for host product evaluation for different operational conditions for a stand-alone modular transmitter in a host, versus with multiple, simultaneously transmitting modules or other transmitters in a host.

Grantees can increase the utility of their modular transmitters by providing special means, modes, or instructions that simulates or characterizes a connection by enabling a transmitter. This can greatly simplify a host manufacturer’s determination that a module as installed in a host complies with FCC requirements.

Explanation: Top band can increase the utility of our modular transmitters by providing instructions that simulates or characterizes a connection by enabling a transmitter.

2.10 Additional testing, Part 15 Subpart B disclaimer

The grantee should include a statement that the modular transmitter is only FCC authorized for the specific rule parts (i.e., FCC transmitter rules) listed on the grant, and that the host product manufacturer is responsible for compliance to any other FCC rules that apply to the host not covered by the modular transmitter grant of certification. If the grantee markets their product as being Part 15 Subpart B compliant (when it also contains unintentional-radiator digital circuitry), then the grantee shall provide a notice stating that the final host product still requires Part 15 Subpart B compliance testing with the modular transmitter installed.

Explanation: The module without unintentional-radiator digital circuitry, so the module does not require an evaluation by FCC Part 15 Subpart B. The host should be evaluated by the FCC Subpart B.