

TEST REPORT

Report No.: BCTC2212116652-2E

Applicant: Ningbo Pelican Smart Fishing Tackle Co., Ltd

Product Name: CatchX Pro

Model/Type
reference: CN-0000B1AP01

Tested Date: 2022-12-19 to 2023-01-09

Issued Date: 2023-01-11



Shenzhen BCTC Testing Co., Ltd.



FCC ID: 2ASTRCN-0000B1

Product Name: CatchX Pro
Trademark: N/A
Model/Type reference: CN-0000B1AP01
Prepared For: Ningbo Pelican Smart Fishing Tackle Co., Ltd
Address: No.16, Yongchang Road, Chengdong Industrial Park, Xiangshan County, Ningbo City, Zhejiang Province, China
Manufacturer: Ningbo Pelican Smart Fishing Tackle Co., Ltd
Address: No.16, Yongchang Road, Chengdong Industrial Park, Xiangshan County, Ningbo City, Zhejiang Province, China
Prepared By: Shenzhen BCTC Testing Co., Ltd.
Address: 1-2/F., Building B, Pengzhou Industrial Park, No.158, Fuyuan 1st Road, Zhancheng, Fuhai Subdistrict, Bao'an District, Shenzhen, Guangdong, China
Sample Received Date: 2022-12-19
Sample tested Date: 2022-12-19 to 2023-01-09
Issue Date: 2023-01-11
Report No.: BCTC2212116652-2E
FCC Part15 15.407
Test Standards: ANSI C63.10-2013
KDB 662911 D01 v02r01
KDB 789033 D02 v02r01
Test Results: PASS
Remark: This is WIFI-5GHz band radio test report.

Tested by:

Eric Yang/Project Handler

Approved by:

Zero Zhou/Reviewer

The test report is effective only with both signature and specialized stamp. This result(s) shown in this report refer only to the sample(s) tested. Without written approval of Shenzhen BCTC Testing Co., Ltd, this report can't be reproduced except in full. The tested sample(s) and the sample information are provided by the client.



Table Of Content

	Page
Test Report Declaration	
1. Version	5
2. Test Summary	6
3. Measurement Uncertainty	7
4. Product Information And Test Setup	8
4.1 Product Information	8
4.2 Test Setup Configuration	9
4.3 Support Equipment	9
4.4 Channel List	10
4.5 Test Mode	11
4.6 Table Of Parameters Of Text Software Setting	11
4.7 Antenna	11
5. Test Facility And Test Instrument Used	12
5.1 Test Facility	12
5.2 Test Instrument Used	12
6. Conducted Emissions	14
6.1 Block Diagram Of Test Setup	14
6.2 Limit	14
6.3 Test procedure	14
6.4 EUT operating Conditions	14
6.5 Test Result	15
7. Radiated Emissions	17
7.1 Block Diagram Of Test Setup	17
7.2 Limit	18
7.3 Test procedure	19
7.4 EUT operating Conditions	20
7.5 Test Result	20
8. Power Spectral Density Test	26
8.1 Block Diagram Of Test Setup	26
8.2 Limit	26
8.3 Test procedure	27
8.4 EUT operating Conditions	27
8.5 Test Result	28
9. 26dB & 6dB & 99% Emission Bandwidth	33
9.1 Block Diagram Of Test Setup	33
9.2 Limit	33
9.3 Test procedure	33
9.4 EUT operating Conditions	34
9.5 Test Result	34
10. Maximum Conducted Output Power	43
10.1 Block Diagram Of Test Setup	43
10.2 Limit	43
10.3 Test procedure	43
10.4 EUT operating Conditions	44
10.5 Test Result	45
11. Out Of Band Emissions	46

BCTC
 3C
 PPR
 检测

11.1	Block Diagram Of Test Setup.....	46
11.2	Limit	46
11.3	Test procedure	46
11.4	EUT operating Conditions	46
11.5	Test Result	47
12.	Spurious RF Conducted Emissions.....	50
12.1	Block Diagram Of Test Setup.....	50
12.2	Limit	50
12.3	Test procedure	50
12.4	Test Result	50
13.	Frequency Stability Measurement	55
13.1	Block Diagram Of Test Setup.....	55
13.2	Limit	55
13.3	Test procedure	55
13.4	Test Result	56
14.	Antenna Requirement	59
14.1	Limit	59
14.2	Test Antenna.....	59
15.	EUT Photographs.....	60
16.	EUT Test Setup Photographs.....	61

(Note: N/A Means Not Applicable)

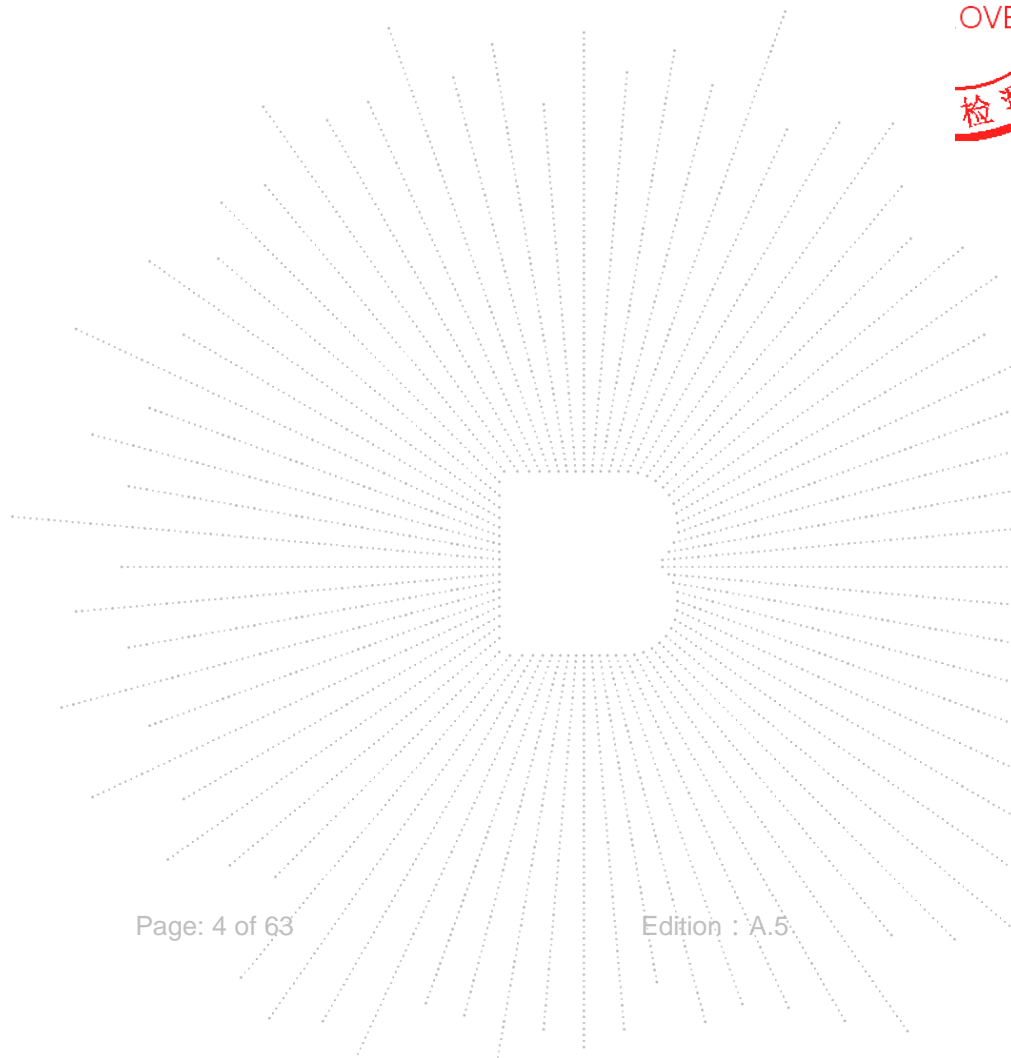

TEC
TC
OVER
檢

1. Version

Report No.	Issue Date	Description	Approved
BCTC2212116652-2E	2023-01-11	Original	Valid

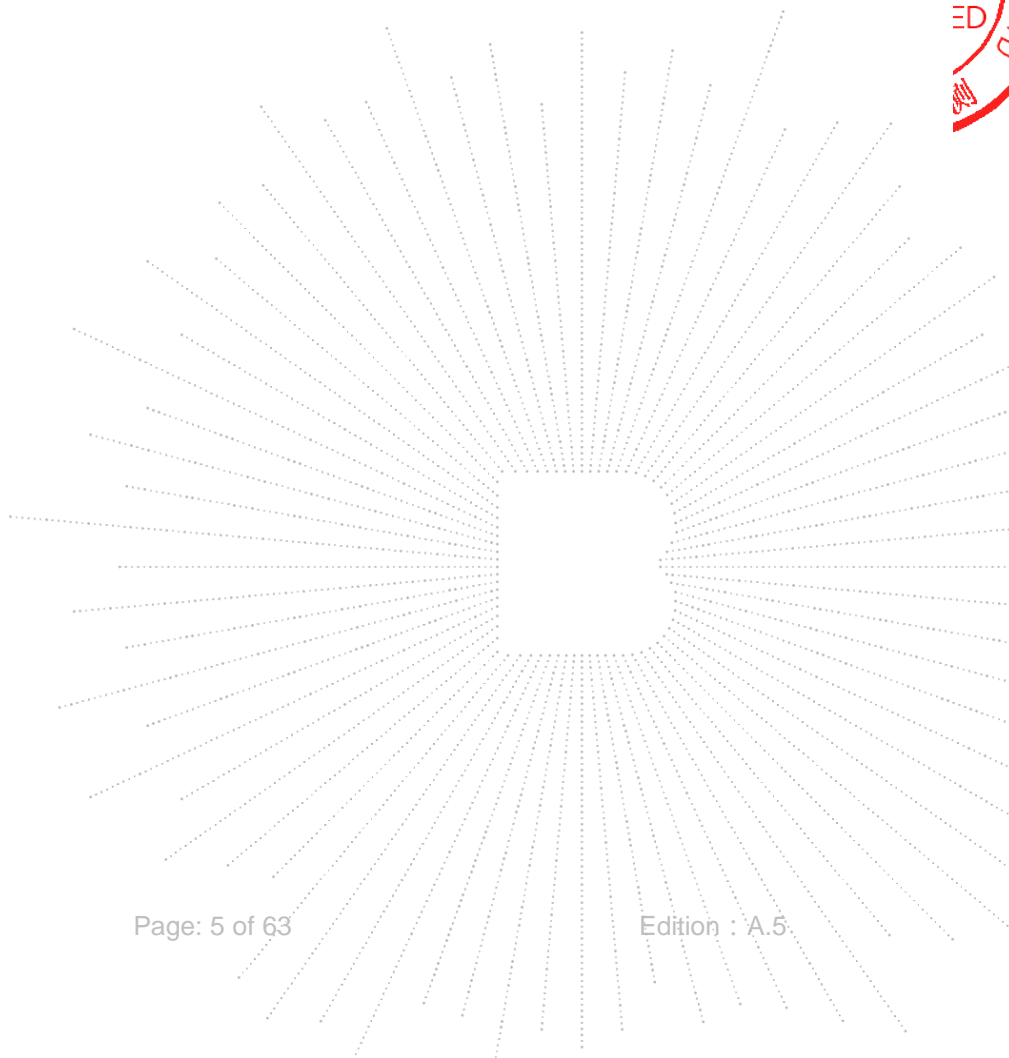

2. Test Summary

The Product has been tested according to the following specifications:

1	Test Parameter	Clause No.	Results
1	Spurious Radiated Emissions	15.209(a), 15.407 (b)(1) 15.407 (b)(4) 15.407 (b)(8)	PASS
2	Conducted Emission	15.207	PASS
3	26 dB and 99% Emission Bandwidth	15.407 (a)(12) 15.1049	PASS
4	Minimum 6 dB bandwidth	15.407(e)	PASS
5	Maximum Conducted Output Power	15.407 (a)(1) 15.407 (a)(3)	PASS
6	Band Edge	2.1051, 15.407(b)(1) 15.407(b)(4)	PASS
7	Power Spectral Density	15.407 (a)(1) 15.407 (a)(3)	PASS
8	Spurious Emissions at Antenna Terminals	2.1051, 15.407(b)	PASS
9	Antenna Requirement	15.203	PASS

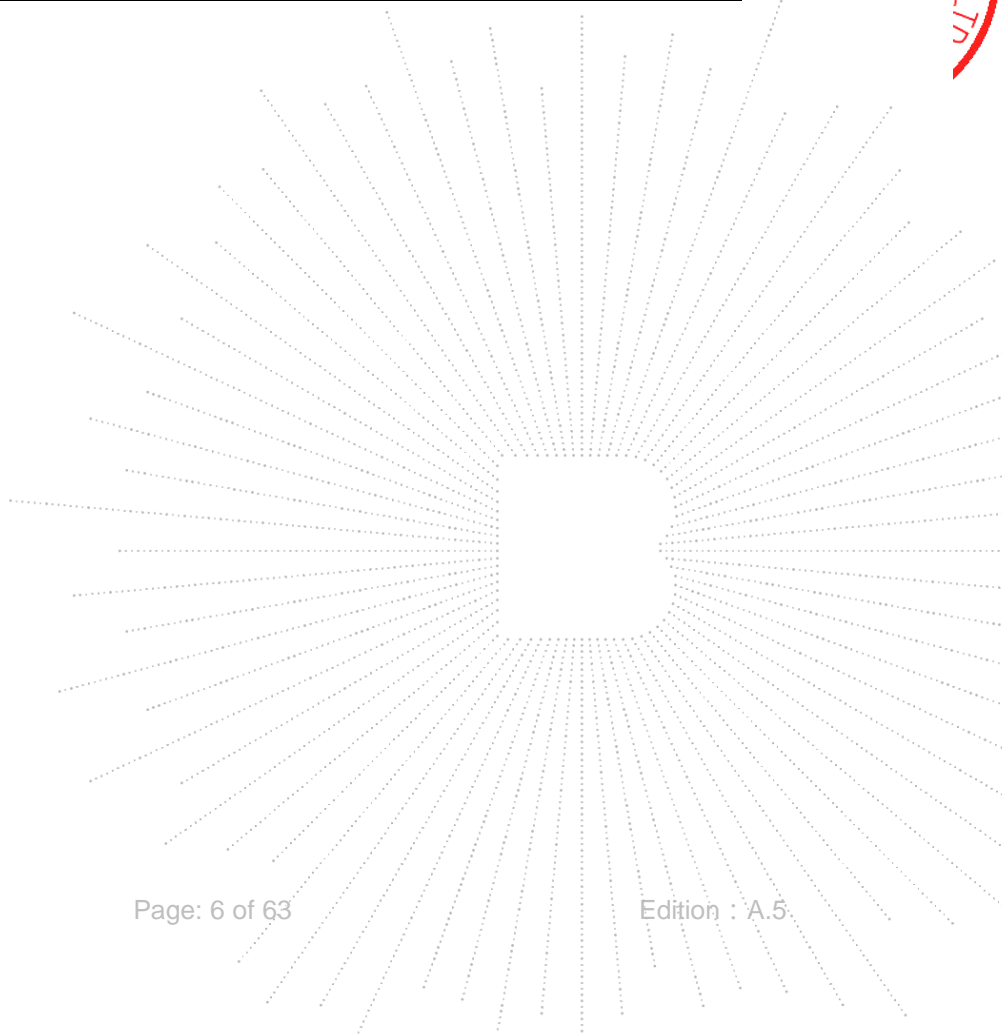
3. Measurement Uncertainty

Where relevant, the following measurement uncertainty levels have been estimated for tests performed on the Product as specified in CISPR 16-4-2. This uncertainty represents an expanded uncertainty expressed at approximately the 95% confidence level using a coverage factor of k=2.

No.	Item	Uncertainty
1	3m chamber Radiated spurious emission(30MHz-1GHz)	U=4.3dB
2	3m chamber Radiated spurious emission(9KHz-30MHz)	U=3.7dB
3	3m chamber Radiated spurious emission(1GHz-18GHz)	U=4.5dB
4	3m chamber Radiated spurious emission(18GHz-40GHz)	U=3.34dB
5	Conducted Emission (150kHz-30MHz)	U=3.20dB
6	Conducted Adjacent channel power	U=1.38dB
7	Conducted output power uncertainty Above 1G	U=1.576dB
8	Conducted output power uncertainty below 1G	U=1.28dB
9	humidity uncertainty	U=5.3%
10	Temperature uncertainty	U=0.59°C

4. Product Information And Test Setup

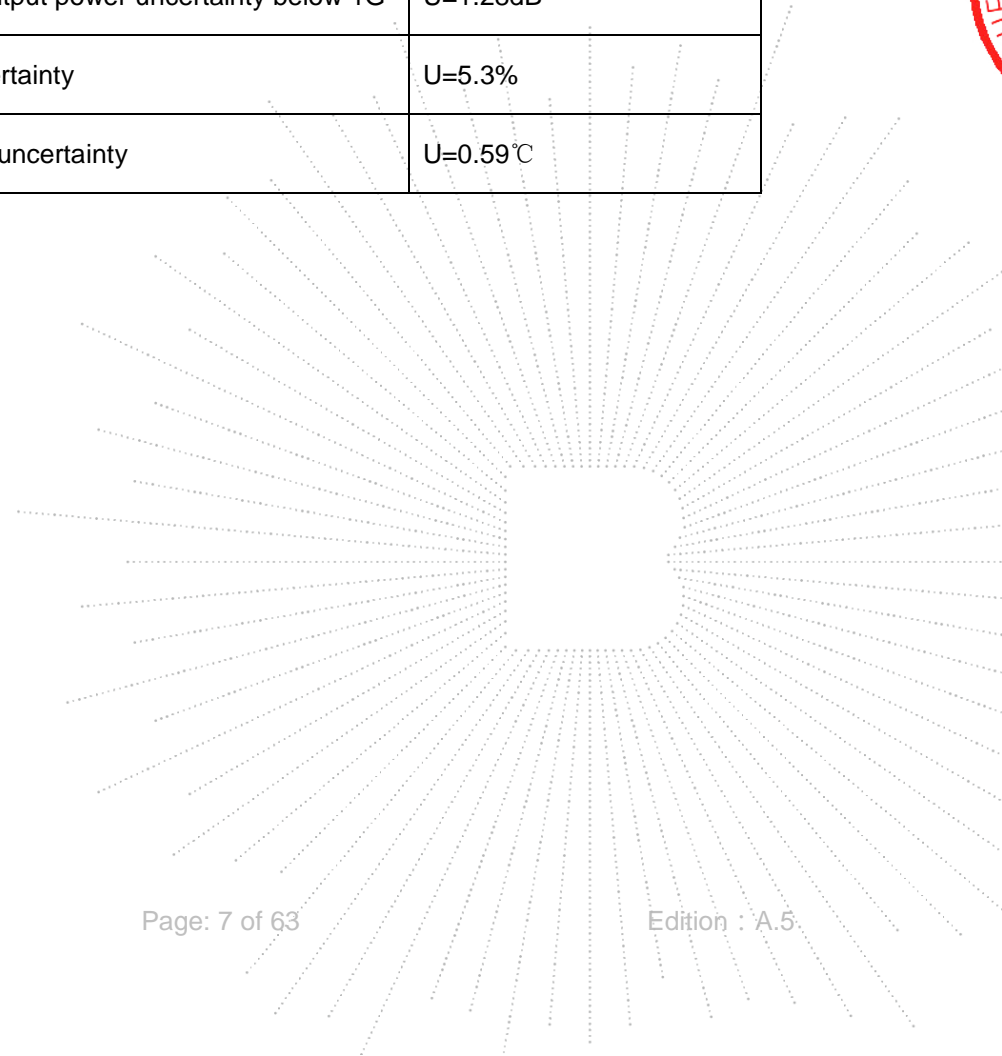
4.1 Product Information

Model/Type reference:	CN-0000B1AP01
Model differences:	N/A
IEEE 802.11 WLAN Mode Supported:	802.11a/n (20MHz channel bandwidth) 802.11n (40MHz channel bandwidth)
Operation Frequency:	5745-5825 MHz for 802.11a/n(HT20); 5755-5795 MHz for 802.11a/n(HT40).
Data Rate:	802.11a: 6,9,12,18,24,36,48,54Mbps; 802.11n(HT20/HT40):MCS0-MCS15.
Type of Modulation:	OFDM with BPSK/QPSK/16QAM/64QAM/256QAM for 802.11a/n.
Number Of Channel:	5 channels for 802.11a/n20 in the 5745-5825MHz band ; 2 channels for 802.11 n40 in the 5755-5795MHz band.
Antenna installation:	External antenna *2
Antenna Gain:	A&B: 2.84 dBi
Ratings:	DC 11.1V From Battery, DC 12.6V From Adapter
Adapter:	MODEL: JN-84W-126500 INPUT: 100-240V~ 50/60Hz 2.0A OUTPUT: DC 12.6V 5A



4.2 Test Setup Configuration

See test photographs attached in *EUT TEST SETUP PHOTOGRAPHS* for the actual connections between Product and support equipment.

Conducted Emission:

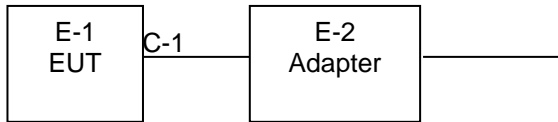

Radiated Spurious Emission

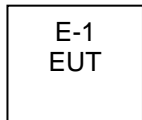

4.3 Support Equipment

No.	Device Type	Brand	Model	Series No.	Note
E-2	Adapter	N/A	JN-84W-126500	N/A	

Item	Shielded Type	Ferrite Core	Length	Note
C-1	N/A	N/A	1.1M	DC cable unshielded

Notes:

- All the equipment/cables were placed in the worst-case configuration to maximize the emission during the test.
- Grounding was established in accordance with the manufacturer's requirements and conditions for the intended use.

4.4 Channel List

Frequency and Channel list for 802.11a/n20 (5745-5825MHz):

802.11a/n (20MHz) Carrier Frequency Channel							
Channel	Frequency (MHz)	Channel	Frequency (MHz)	Channel	Frequency (MHz)	Channel	Frequency (MHz)
149	5745	153	5765	157	5785	161	5805
165	5825	-	-	-	-	-	-

802.11n (40MHz) Carrier Frequency Channel							
Channel	Frequency (MHz)	Channel	Frequency (MHz)	Channel	Frequency (MHz)	Channel	Frequency (MHz)
151	5755	159	5795	-	-	-	-

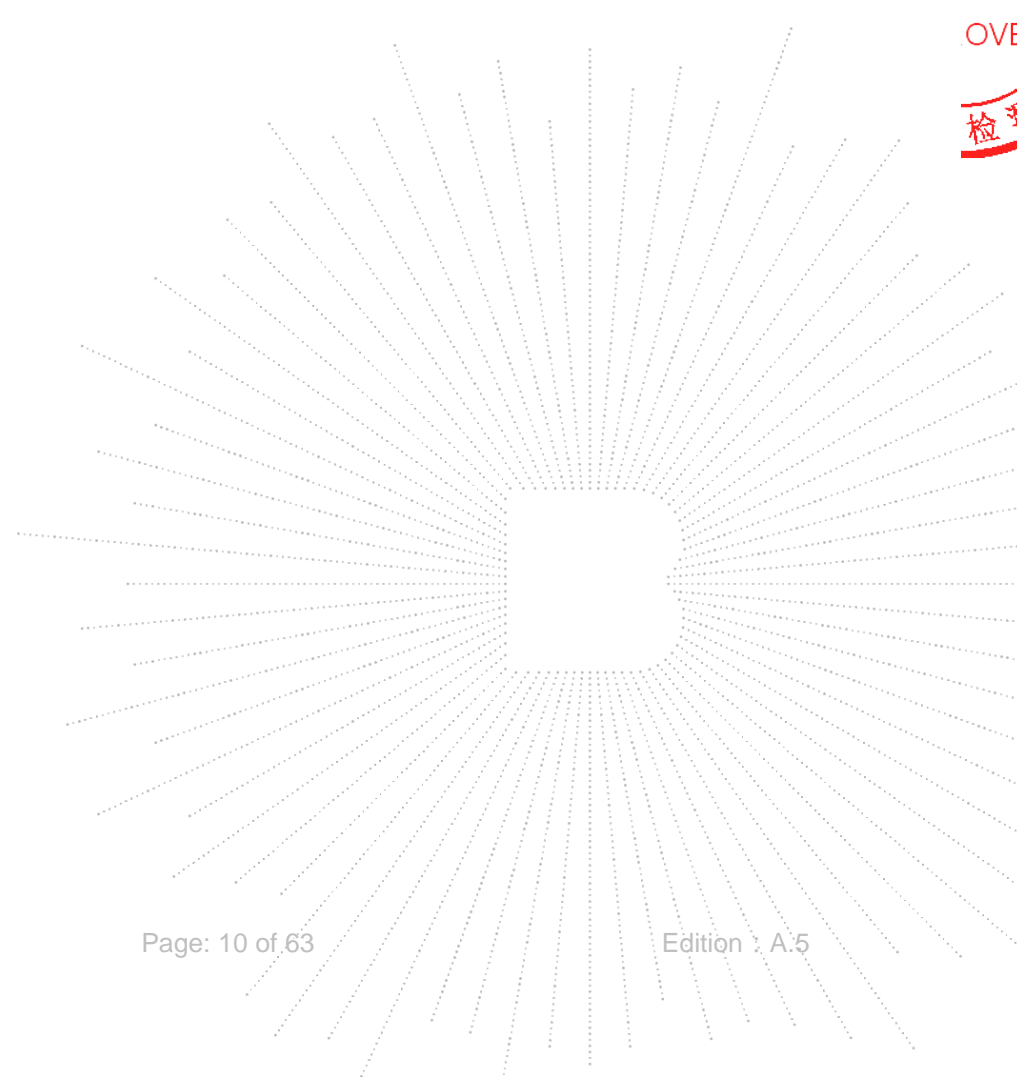

検査
 OVER
 TC
 TE

4.5 Test Mode

To investigate the maximum EMI emission characteristics generates from EUT, the test system was pre-scanning tested base on the consideration of following EUT operation mode or test configuration mode which possible have effect on EMI emission level. Each of these EUT operation mode(s) or test configuration mode(s) mentioned above was evaluated respectively.

Pretest Mode	Description
Mode 1	802.11a /n20 CH149/ CH157/ CH 165
Mode 2	802.11n40 CH 151 / CH 159
Mode 3	Link mode (Radiated emission)
Mode 4	Charging (Conducted emission)

Note: The measurements are performed at all Bit Rate of Transmitter, the worst data was reported.

4.6 Table Of Parameters Of Text Software Setting

During testing channel & power controlling software provided by the customer was used to control the operating channel as well as the output power level. The RF output power selection is for the setting of RF output power expected by the customer and is going to be fixed on the firmware of the final end product power parameters

Test software Version	CMD		
Parameters	DEF	DEF	DEF

4.7 Antenna

Table for External antenna

Ant.	Brand	Model Name	Antenna Type	Gain (dBi)	NOTE
A	N/A	N/A	External antenna	2.84	5.8GHz
B	N/A	N/A	External antenna	2.84	5.8GHz

EUT has two External antennas with Max gain GANT 2.84dBi on every antenna, CDD device with two spatial streams, also can operat with one spatial streams according to KDB662911 D01 v02r01, Directional gain= GANT + Array Gain, where Array Gain is as follows.

- 1)For power spectral density(PSD) measurements,
 $\text{Array Gain} = 10\log(\text{NANT}/\text{NSS})\text{dB} = 10\log(2/1) = 3.01\text{dB}$,
 So the directional gain for PSD is 5.85dBi
- 2)For power measurements,
 The Array gain=0 dB for $\text{NANT} \leq 4$,
 So the directional gain for Power measurements is 2.84dBi

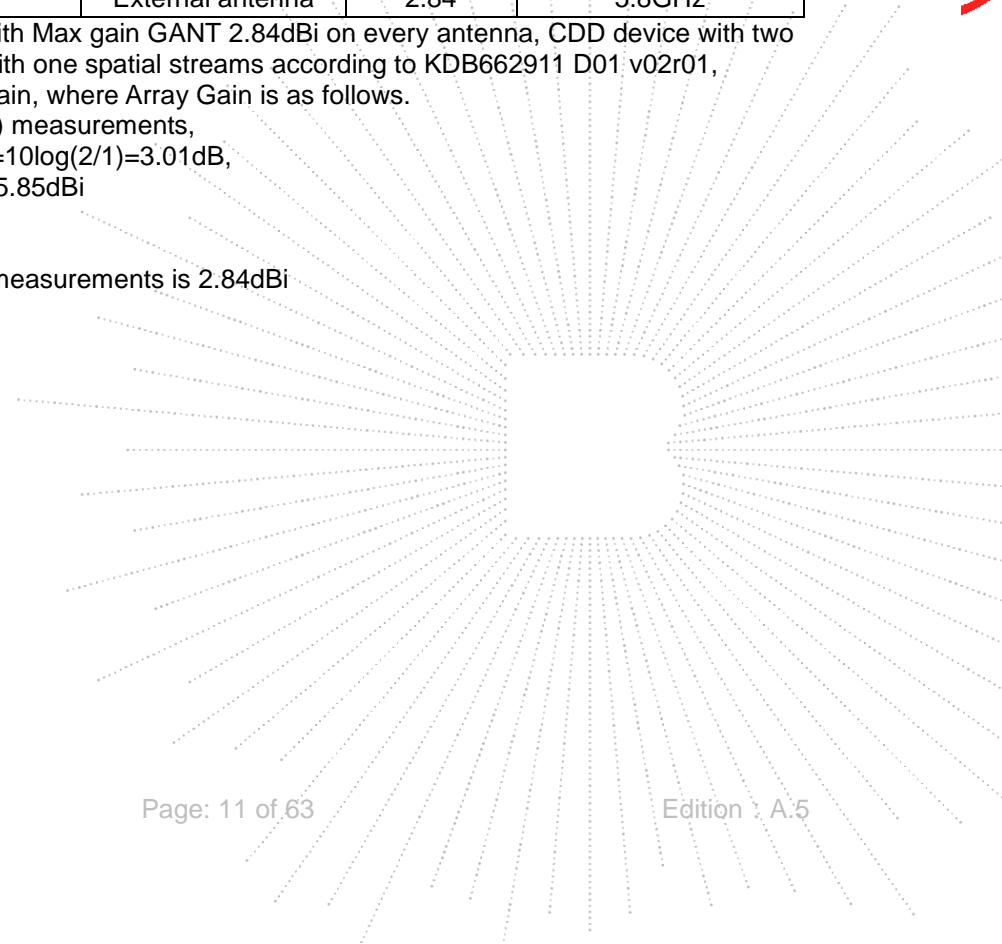

5. Test Facility And Test Instrument Used

5.1 Test Facility

All measurement facilities used to collect the measurement data are located at Shenzhen BCTC Testing Co., Ltd. Address:1-2/F., Building B, Pengzhou Industrial Park, No.158, Fuyuan 1st Road, Zhancheng, Fuhai Subdistrict, Bao'an District, Shenzhen, Guangdong, China. The site and apparatus are constructed in conformance with the requirements of ANSI C63.4 and CISPR 16-1-1 other equivalent standards.

FCC Test Firm Registration Number: 712850

IC Registered No.: 23583

5.2 Test Instrument Used

Conducted Emissions Test					
Equipment	Manufacturer	Model#	Serial#	Last Cal.	Next Cal.
Receiver	R&S	ESR3	102075	May 24, 2022	May 23, 2023
LISN	R&S	ENV216	101375	May 24, 2022	May 23, 2023
Software	Frad	EZ-EMC	EMC-CON 3A1	\	\
Attenuator	\	10dB C-6GHz	1650	May 24, 2022	May 23, 2023

RF Conducted Test					
Equipment	Manufacturer	Model#	Serial#	Last Cal.	Next Cal.
Power Meter	Keysight	E4419	\	May 24, 2022	May 23, 2023
Power Sensor (AV)	Keysight	E9300A	\	May 24, 2022	May 23, 2023
Signal Analyzer20kHz-26.5GHz	Keysight	N9020A	MY49100060	May 24, 2022	May 23, 2023
Spectrum Analyzer9kHz-40GHz	R&S	FSP40	100363	May 24, 2022	May 23, 2023
Radio frequency control box	MAIWEI	MW100-RFC B	\	\	\
Software	MAIWEI	MTS 8310	\	\	\

Radiated Emissions Test (966 Chamber01)					
Equipment	Manufacturer	Model#	Serial#	Last Cal.	Next Cal.
966 chamber	ChengYu	966 Room	966	Jun. 06. 2020	Jun. 05, 2023
Receiver	R&S	ESR3	102075	May 24, 2022	May 23, 2023
Receiver	R&S	ESRP	101154	May 24, 2022	May 23, 2023
Amplifier	Schwarzbeck	BBV9744	9744-0037	May 24, 2022	May 23, 2023
TRILOG Broadband Antenna	Schwarzbeck	VULB9163	942	May 26, 2022	May 25, 2023
Loop Antenna(9KHz -30MHz)	Schwarzbeck	FMZB1519B	00014	May 26, 2022	May 25, 2023
Amplifier	SKET	LAPA_01G18 G-45dB	\	May 24, 2022	May 23, 2023
Horn Antenna	Schwarzbeck	BBHA9120D	1541	Jun. 06, 2022	Jun. 05, 2023
Amplifier(18G Hz-40GHz)	MITEQ	TTA1840-35-HG	2034381	May 26, 2022	May 25, 2023
Horn Antenn(18GHz-40GHz)	Schwarzbeck	BBHA9170	00822	Jun. 06, 2022	Jun. 05, 2023
Spectrum Analyzer9kHz-40GHz	R&S	FSP40	100363	May 24, 2022	May 23, 2023
Software	Frad	EZ-EMC	FA-03A2 RE	\	\

SHENZHEN

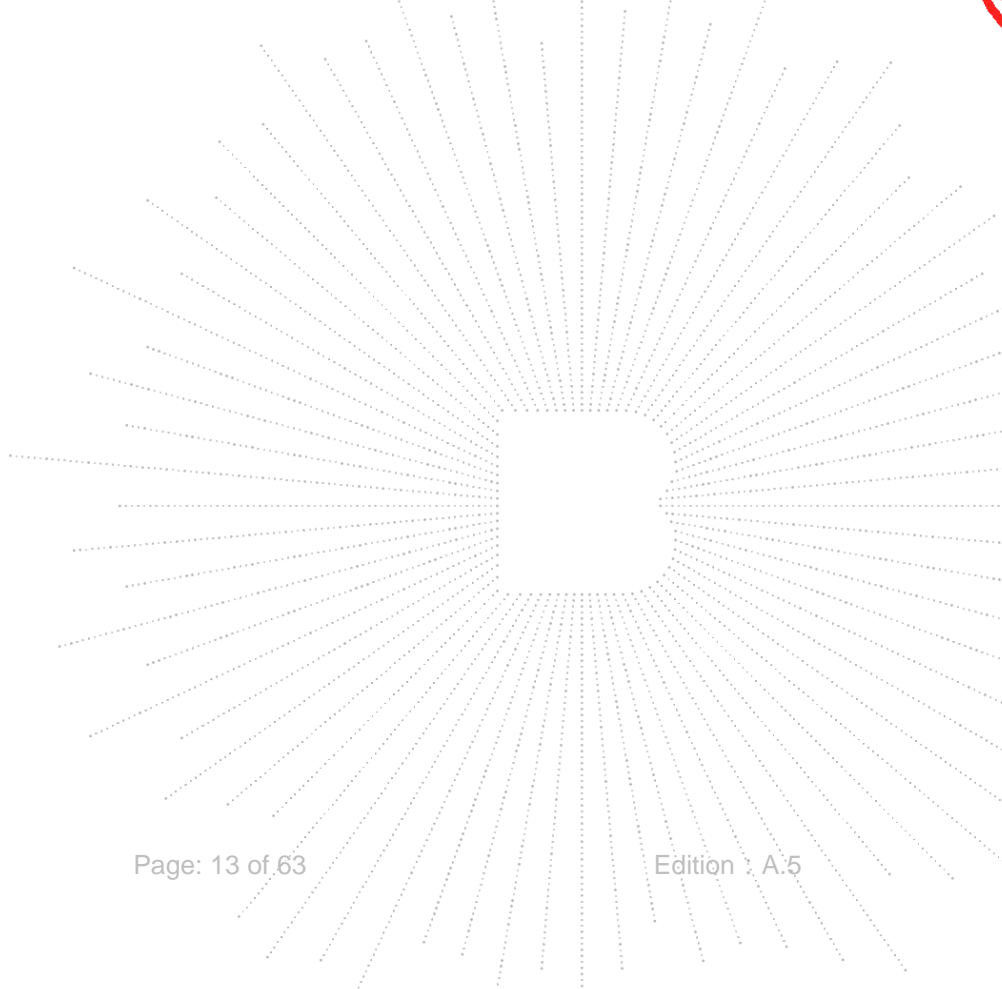

6. Conducted Emissions

6.1 Block Diagram Of Test Setup

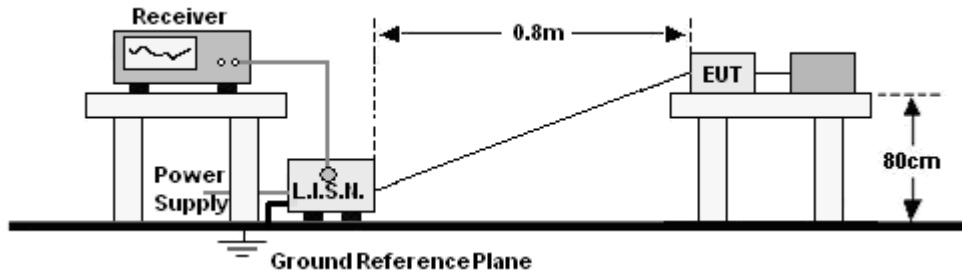

6.2 Limit

Frequency (MHz)	Limit (dBuV)	
	Quas-peak	Average
0.15 -0.5	66 - 56 *	56 - 46 *
0.50 -5.0	56.00	46.00
5.0 -30.0	60.00	50.00

Notes:

- *Decreasing linearly with logarithm of frequency.
- The lower limit shall apply at the transition frequencies.

6.3 Test procedure

Receiver Parameters	Setting
Attenuation	10 dB
Start Frequency	0.15 MHz
Stop Frequency	30 MHz
IF Bandwidth	9 kHz

- The Product was placed on a nonconductive table 0.8 m above the horizontal ground reference plane, and 0.4 m from the vertical ground reference plane, and connected to the main through Line Impedance Stability Network (L.I.S.N).
- The RBW of the receiver was set at 9 kHz in 150 kHz ~ 30MHz with Peak and AVG detector in Max Hold mode. Run the receiver's pre-scan to record the maximum disturbance generated from Product in all power lines in the full band.
- For each frequency whose maximum record was higher or close to limit, measure its QP and AVG values and record.

6.4 EUT operating Conditions

The EUT was configured for testing in a typical fashion (as a customer would normally use it). The EUT has been programmed to continuously transmit during test. This operating condition was tested and used to collect the included data.

We pretest AC 120V and AC 240V, the worst voltage was AC 120V and the data recording in the report.

6.5 Test Result

Temperature:	26 °C	Relative Humidity:	54%
Pressure:	101KPa	Test Voltage :	AC120V/60Hz
Test Mode:	Mode 4	Polarization :	L

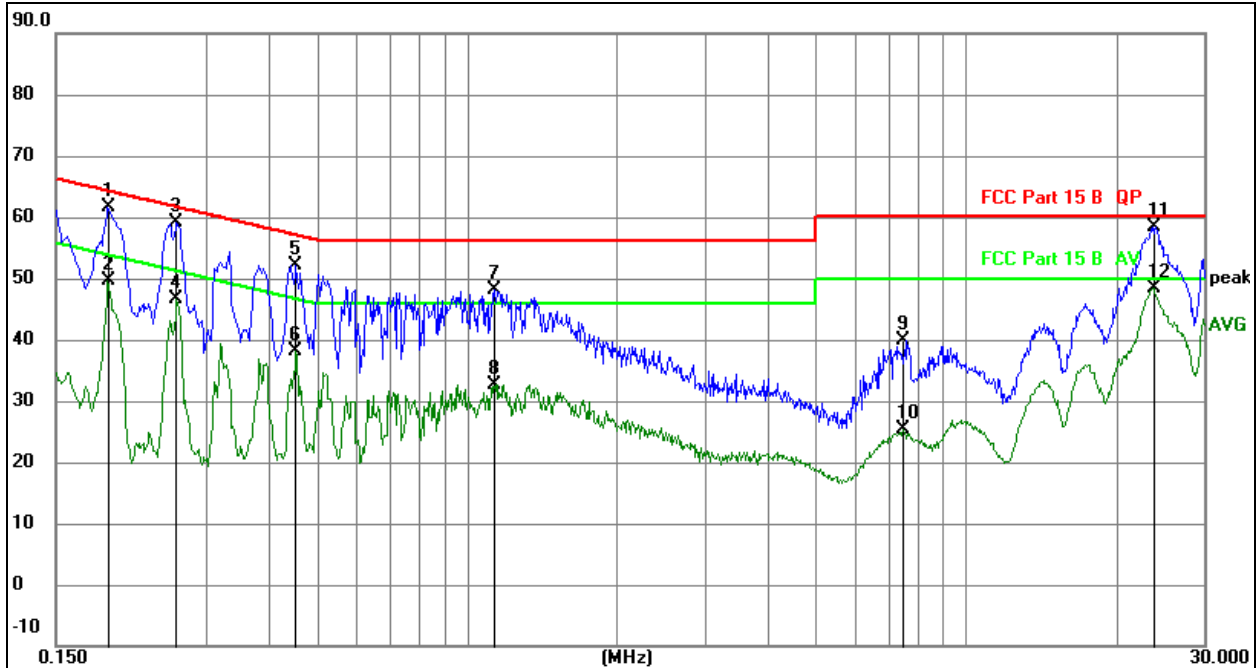

Remark:

1. All readings are Quasi-Peak and Average values.
2. Factor = Insertion Loss + Cable Loss.
3. Measurement = Reading Level + Correct Factor
4. Over = Measurement - Limit

No.	Mk.	Freq. MHz	Reading Level	Correct Factor dB	Measure- ment dBuV	Limit dBuV	Over dB	Detector
1		0.1904	41.84	19.78	61.62	64.02	-2.40	QP
2		0.1904	29.92	19.78	49.70	54.02	-4.32	AVG
3		0.2615	39.34	19.78	59.12	61.38	-2.26	QP
4		0.2615	26.82	19.78	46.60	51.38	-4.78	AVG
5		0.4539	32.33	19.73	52.06	56.80	-4.74	QP
6		0.4539	18.37	19.73	38.10	46.80	-8.70	AVG
7		1.1352	28.31	19.78	48.09	56.00	-7.91	QP
8		1.1352	12.97	19.78	32.75	46.00	-13.25	AVG
9		7.4860	19.75	20.20	39.95	60.00	-20.05	QP
10		7.4860	5.06	20.20	25.26	50.00	-24.74	AVG
11	*	23.6361	37.83	20.52	58.35	60.00	-1.65	QP
12		23.6361	27.76	20.52	48.28	50.00	-1.72	AVG

Temperature:	26 °C	Relative Humidity:	54%
Pressure:	101KPa	Test Voltage :	AC120V/60Hz
Test Mode:	Mode 4	Polarization :	N

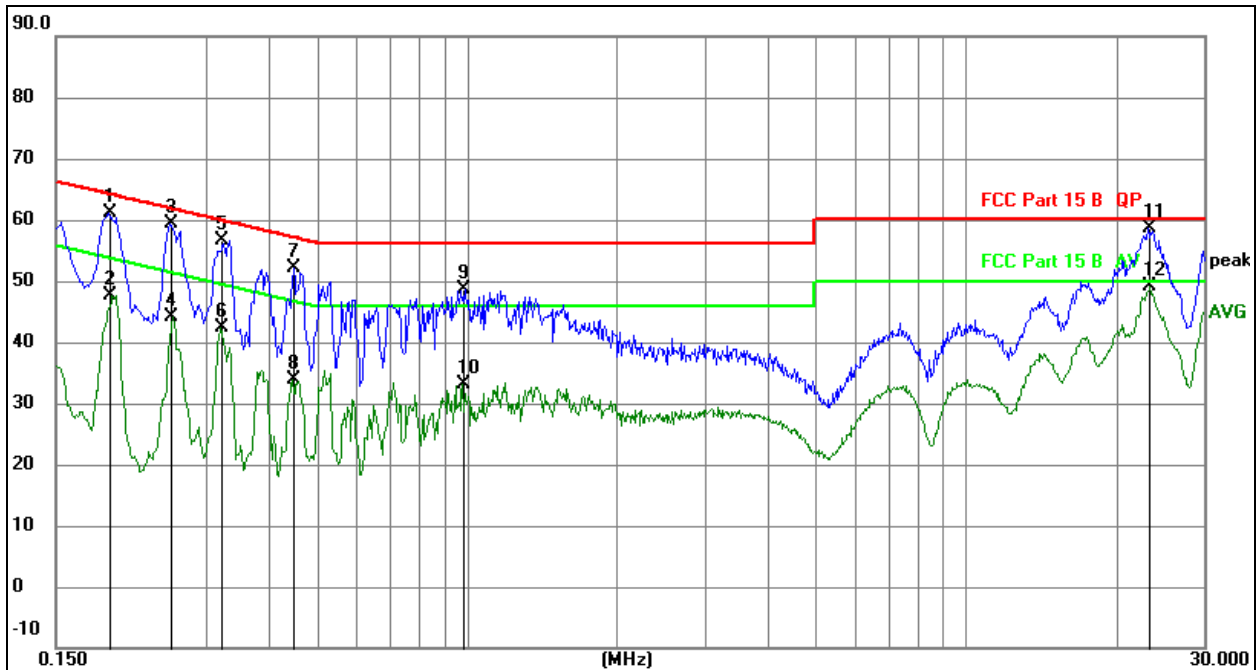
Remark:

1. All readings are Quasi-Peak and Average values.
2. Factor = Insertion Loss + Cable Loss.
3. Measurement = Reading Level + Correct Factor
4. Over = Measurement - Limit

No.	Mk.	Freq. MHz	Reading Level	Correct Factor dB	Measure- ment dBuV	Limit dBuV	Over dB	Detector
1		0.1914	41.29	19.78	61.07	63.98	-2.91	QP
2		0.1914	27.95	19.78	47.73	53.98	-6.25	AVG
3		0.2535	39.68	19.79	59.47	61.64	-2.17	QP
4		0.2535	24.26	19.79	44.05	51.64	-7.59	AVG
5		0.3209	36.96	19.77	56.73	59.68	-2.95	QP
6		0.3209	22.52	19.77	42.29	49.68	-7.39	AVG
7		0.4470	32.44	19.73	52.17	56.93	-4.76	QP
8		0.4470	14.12	19.73	33.85	46.93	-13.08	AVG
9		0.9825	28.76	19.76	48.52	56.00	-7.48	QP
10		0.9825	13.37	19.76	33.13	46.00	-12.87	AVG
11		23.1785	38.07	20.52	58.59	60.00	-1.41	QP
12	*	23.1785	28.54	20.52	49.06	50.00	-0.94	AVG

検査
 OVER
 TC
 TE

7. Radiated Emissions

7.1 Block Diagram Of Test Setup

(A) Radiated Emission Test-Up Frequency Below 30MHz

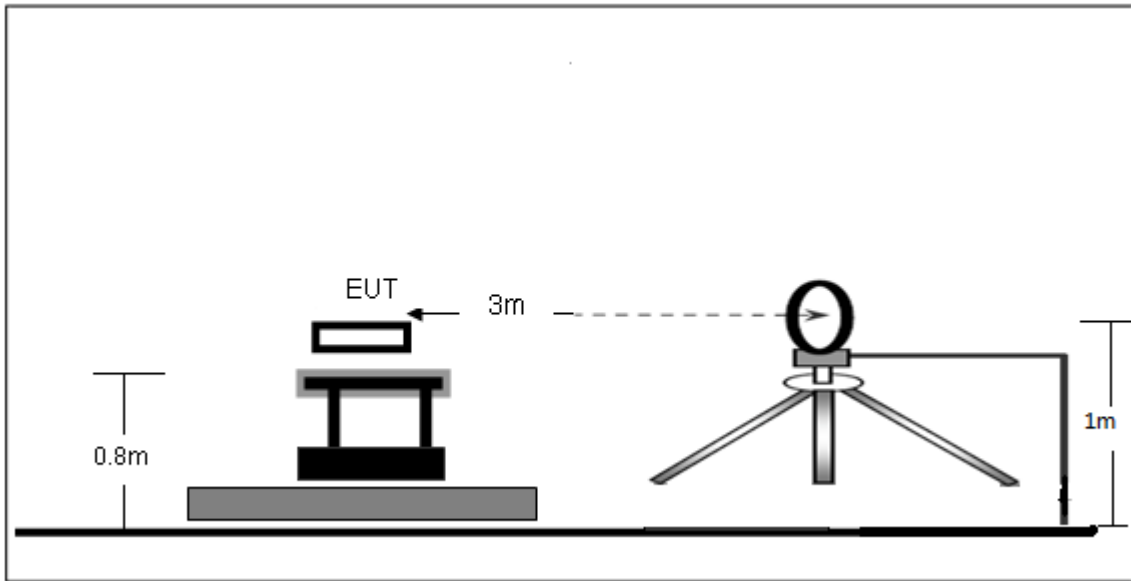

(B) Radiated Emission Test-Up Frequency 30MHz~1GHz

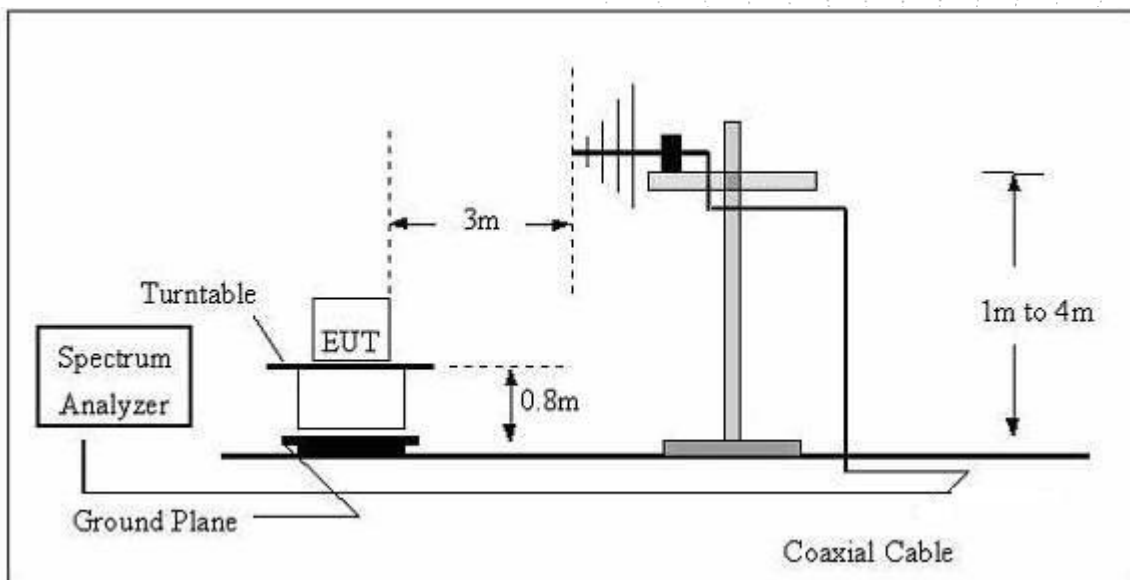

(C) Radiated Emission Test-Up Frequency Above 1GHz

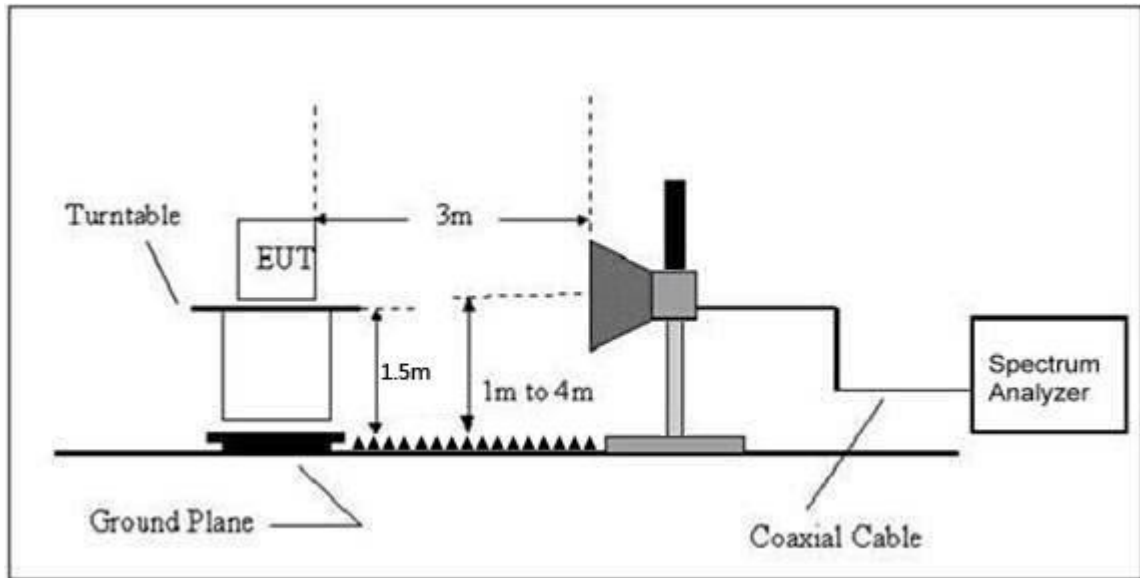
7.2 Limit

20dBc in any 100 kHz bandwidth outside the operating frequency band. In case the emission fall within the restricted band specified on 15.205(a), then the 15.209(a) limit in the table below has to be followed.

Frequency (MHz)	Field Strength uV/m	Distance (m)	Field Strength Limit at 3m Distance	
			uV/m	dBuV/m
0.009 ~ 0.490	2400/F(kHz)	300	$10000 * 2400/F(\text{kHz})$	$20\log^{(2400/F(\text{kHz}))} + 80$
0.490 ~ 1.705	24000/F(kHz)	30	$100 * 24000/F(\text{kHz})$	$20\log^{(24000/F(\text{kHz}))} + 40$
1.705 ~ 30	30	30	$100 * 30$	$20\log^{(30)} + 40$
30 ~ 88	100	3	100	$20\log^{(100)}$
88 ~ 216	150	3	150	$20\log^{(150)}$
216 ~ 960	200	3	200	$20\log^{(200)}$
Above 960	500	3	500	$20\log^{(500)}$

Limits Of Radiated Emission Measurement (Above 1000MHz)

Frequency (MHz)	Limit (dBuV/m) (at 3M)	
	Peak	Average
Above 1000	74	54

Notes:

- (1) The limit for radiated test was performed according to FCC PART 15C.
- (2) The tighter limit applies at the band edges.
- (3) Emission level (dBuV/m) = $20\log$ Emission level (uV/m).

7.3 Test procedure

The test site semi-anechoic chamber has met the requirement of NSA tolerance 4 dB according to the standards: ANSI C63.10-2013. The test distance is 3m. The setup is according to the requirements in Section 13.1.4.1 of ANSI C63.10-2013 and CAN/CSA-CEI/IEC CISPR 22.

This test is required for any spurious emission that falls in a Restricted Band, as defined in Section 15.205.

It must be performed with the highest gain of each type of antenna proposed for use with the EUT. Use the following spectrum analyzer settings:

Spectrum Parameter	Setting
Attenuation	Auto
Start Frequency	1000 MHz
Stop Frequency	10th carrier harmonic
RB / VB (emission in restricted band)	1 MHz / 1 MHz for Peak, 1 MHz / 10Hz for Average

Receiver Parameter	Setting
Attenuation	Auto
Start ~ Stop Frequency	9kHz~150kHz / RB 200Hz for QP
Start ~ Stop Frequency	150kHz~30MHz / RB 9kHz for QP
Start ~ Stop Frequency	30MHz~1000MHz / RB 120kHz for QP

- The measuring distance of at 3 m shall be used for measurements at frequency up to 1GHz. For frequencies above 1GHz, any suitable measuring distance may be used.
- The EUT was placed on the top of a rotating table 0.8 m for below 1GHz and 1.5m for above 1GHz the ground at a 3 meter. The table was rotated 360 degrees to determine the position of the highest radiation.
- The height of the equipment or of the substitution antenna shall be 0.8 m for below 1GHz and 1.5m for above 1GHz; the height of the test antenna shall vary between 1 m to 4 m. Both horizontal and vertical polarizations of the antenna are set to make the measurement.
- The initial step in collecting conducted emission data is a spectrum analyzer peak detector mode pre-scanning the measurement frequency range. Significant peaks are then marked and then Quasi Peak detector mode re-measured.
- If the Peak Mode measured value compliance with and lower than Quasi Peak Mode Limit, the EUT shall be deemed to meet QP Limits and then no additional QP Mode measurement performed.
- For the actual test configuration, please refer to the related Item –EUT Test Photos.

Note:

Both horizontal and vertical antenna polarities were tested and performed pretest to three orthogonal axis. The worst case emissions were reported

During the radiated emission test, the Spectrum Analyzer was set with the following configurations:

Frequency Band (MHz)	Function	Resolution bandwidth	Video Bandwidth
30 to 1000	QP	120 kHz	300 kHz
Above 1000	Peak	1 MHz	1 MHz
	Average	1 MHz	10 Hz

Note: for the frequency ranges below 30 MHz, a narrower RBW is used for these ranges but the measured value should add a RBW correction factor (RBWCF) where $RBWCF [dB] = 10 \cdot \lg(100 [kHz] / \text{narrower RBW [kHz]})$. , the narrower RBW is 1 kHz and RBWCF is 20 dB for the frequency 9 kHz to 150 kHz, and the narrower RBW is 10 kHz and RBWCF is 10 dB for the frequency 150 kHz to 30 MHz.

7.4 EUT operating Conditions

The EUT was configured for testing in a typical fashion (as a customer would normally use it). The EUT has been programmed to continuously transmit during test. This operating condition was tested and used to collect the included data.

7.5 Test Result

Below 30MHz

Temperature:	26 °C	Relative Humidity:	54%
Pressure:	101KPa	Test Voltage :	DC 11.1V
Test Mode:	Mode 4	Polarization :	---

Freq. (MHz)	Reading (dBuV/m)	Limit (dBuV/m)	Margin (dB)	State P/F
--	--	--	--	PASS
--	--	--	--	PASS

Note:

The amplitude of spurious emissions which are attenuated by more than 20dB below the permissible value has no need to be reported.

Distance extrapolation factor = $40 \log(\text{specific distance}/\text{test distance})(\text{dB})$;

Limit line = specific limits(dBuV) + distance extrapolation factor.

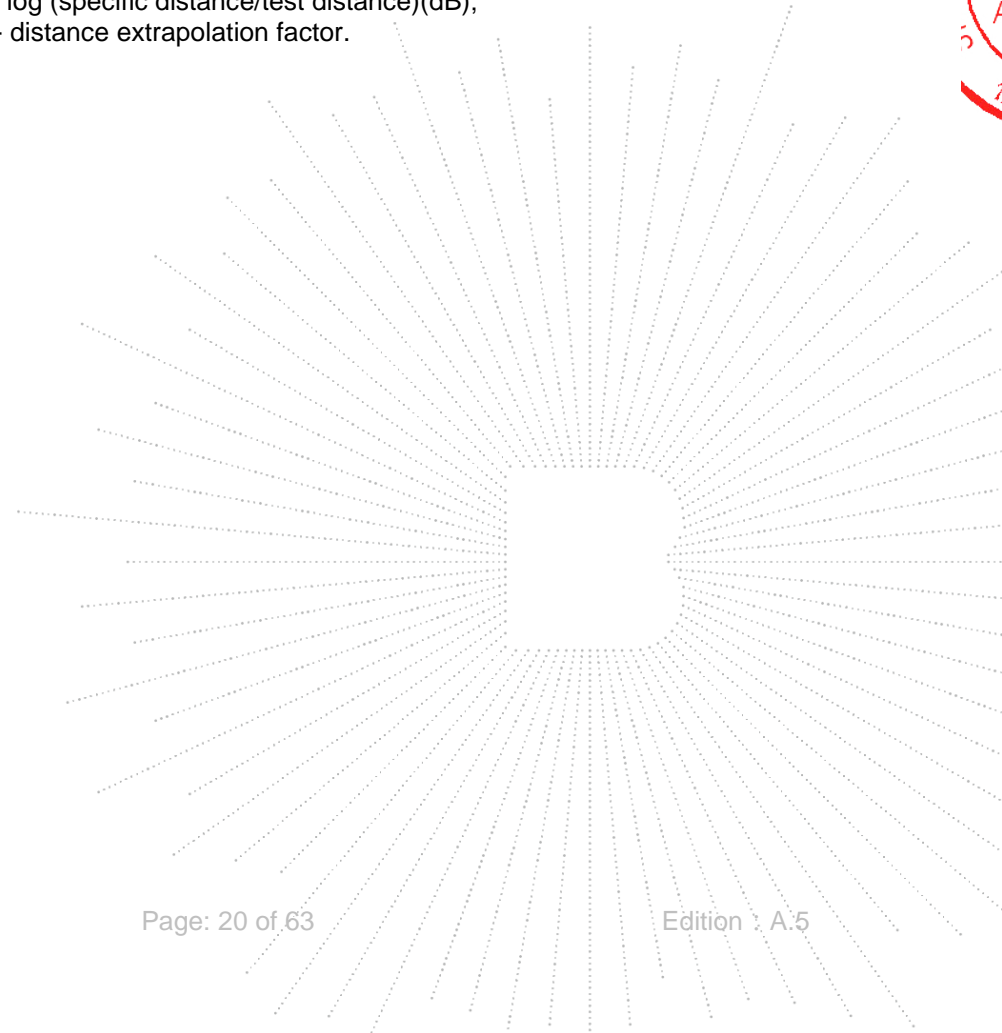

Temperature:	26 °C	Relative Humidity:	54%
Pressure:	101KPa	Test Voltage :	DC 11.1V
Test Mode:	Mode 4	Polarization :	Horizontal

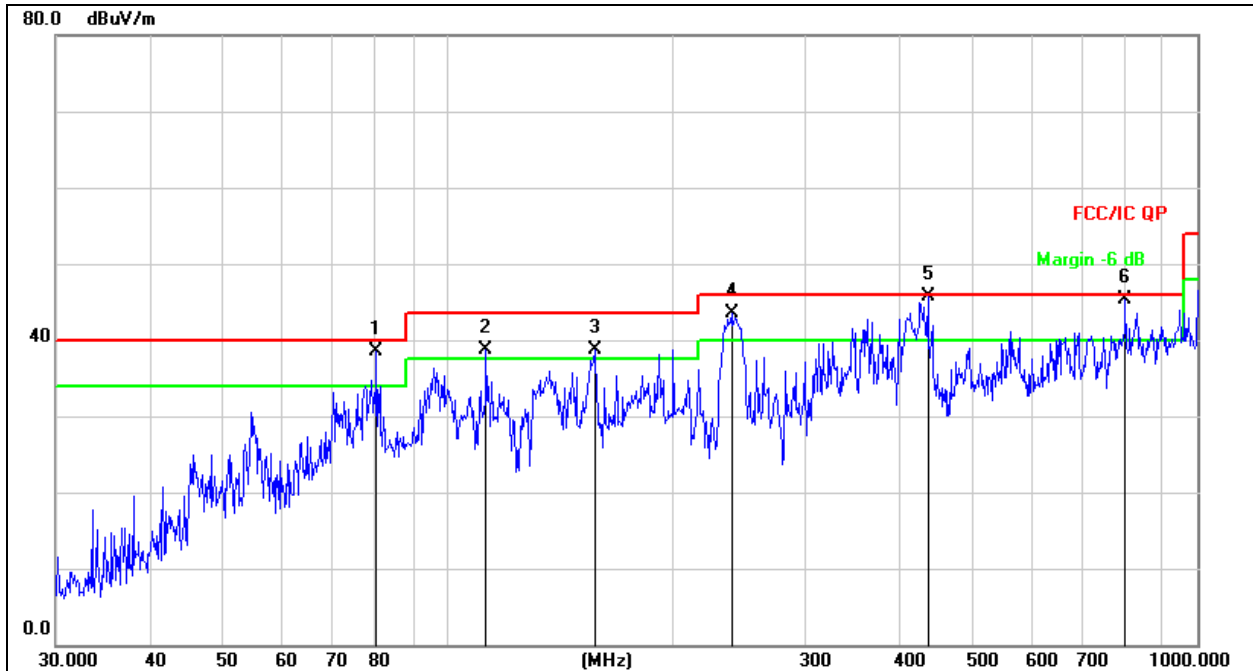
Remark:

1. Factor = Antenna Factor + Cable Loss – Pre-amplifier.
2. Measurement = Reading Level + Correct Factor
3. Over = Measurement - Limit

No.	Mk.	Freq. MHz	Reading Level dBuV	Correct Factor dB	Measure- ment dBuV/m	Limit dB/m	Over dB	Detector
1	!	80.3619	59.92	-21.48	38.44	40.00	-1.56	QP
2	!	112.5241	57.22	-18.58	38.64	43.50	-4.86	QP
3	!	157.0072	59.32	-20.53	38.79	43.50	-4.71	QP
4	!	239.1473	59.68	-16.16	43.52	46.00	-2.48	QP
5	*	437.1197	57.34	-11.68	45.66	46.00	-0.34	QP
6	!	801.7862	50.85	-5.55	45.30	46.00	-0.70	QP

Temperature:	26 °C	Relative Humidity:	54%
Pressure:	101KPa	Test Voltage :	DC 11.1V
Test Mode:	Mode 4	Polarization :	Vertical

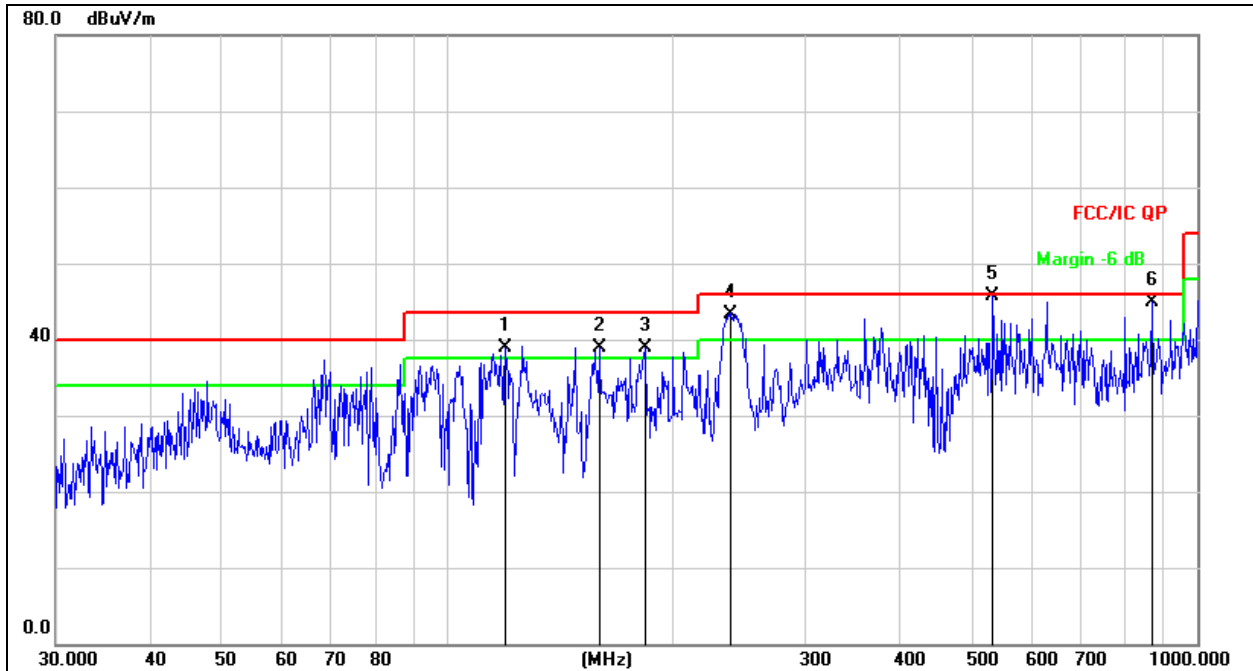

Remark:
 1. Factor = Antenna Factor + Cable Loss – Pre-amplifier.
 2. Measurement = Reading Level + Correct Factor
 3. Over = Measurement - Limit

No.	Mk.	Freq.	Reading Level	Correct Factor	Measurement	Limit	Over	Detector
		MHz	dBuV	dB	dBuV/m	dB/m	dB	
1	!	119.4360	58.01	-19.04	38.97	43.50	-4.53	QP
2	!	159.2249	59.37	-20.37	39.00	43.50	-4.50	QP
3	!	183.2005	57.58	-18.61	38.97	43.50	-4.53	QP
4	!	238.3102	59.59	-16.19	43.40	46.00	-2.60	QP
5	*	533.8318	55.49	-9.76	45.73	46.00	-0.27	QP
6	!	869.1300	49.82	-4.94	44.88	46.00	-1.12	QP

Test Mode:	TX(5.8G) - 802.11a
------------	--------------------

Polar (H/V)	Frequency	Meter Reading	Cable loss	Antenna Factor	Preamp Factor	Emission Level	Limits	Margin	Detector Type
	(MHz)	(dBuV)	(dB)	dB/m	(dB)	(dBuV/m)	(dBuV/m)	(dB)	
Low Channel (5745 MHz)-Above 1G									
V	4679.005	56.81	5.94	35.40	44.00	54.15	74	-19.85	PK
V	4679.005	43.25	5.94	35.40	44.00	40.59	54	-13.41	AV
V	11490.118	54.29	8.46	39.75	44.50	58.00	68.2	-10.20	PK
V	11490.118	43.92	8.46	39.75	44.50	47.63	54	-6.37	AV
V	17235.071	59.93	10.12	38.80	44.10	64.75	68.2	-3.45	PK
V	17235.071	43.70	10.12	38.80	42.70	49.92	54	-4.08	AV
H	4679.009	57.98	5.94	35.18	44.00	55.10	74	-18.90	PK
H	4679.009	43.36	5.94	35.18	44.00	40.48	54	-13.52	AV
H	11490.094	53.54	8.46	38.71	44.50	56.21	68.2	-11.99	PK
H	11490.094	41.87	8.46	38.71	44.50	44.54	54	-9.46	AV
H	17235.094	51.74	10.12	38.38	44.10	56.14	68.2	-12.06	PK
H	17235.094	42.16	10.12	38.38	44.10	46.56	54	-7.44	AV
Middle Channel (5785 MHz)-Above 1G									
V	4592.037	55.14	6.48	36.35	44.05	53.92	74	-20.08	PK
V	4592.037	43.01	6.48	36.35	44.05	41.79	54	-12.21	AV
V	11570.060	59.60	8.47	37.88	44.51	61.44	68.2	-6.76	PK
V	11570.060	43.23	8.47	37.88	44.51	45.07	54	-8.93	AV
V	17355.133	56.42	10.12	38.80	44.10	61.24	68.2	-6.96	PK
V	17355.133	39.20	10.12	38.80	42.70	45.42	54	-8.58	AV
H	4592.050	56.11	6.48	36.37	44.05	54.91	74	-19.09	PK
H	4592.050	43.87	6.48	36.37	44.05	42.67	54	-11.33	AV
H	11570.051	50.00	8.47	38.64	44.50	52.61	68.2	-15.59	PK
H	11570.051	40.08	8.47	38.64	44.50	42.69	54	-11.31	AV
H	17355.173	51.00	10.12	38.38	44.10	55.40	68.2	-12.80	PK
H	17355.173	43.64	10.12	38.38	44.10	48.04	54	-5.96	AV
High Channel (5825 MHz)-Above 1G									
V	6039.120	58.01	7.10	37.24	43.50	58.85	68.2	-9.35	PK
V	6039.120	43.36	7.10	37.24	43.50	44.20	54	-9.80	AV
V	11650.030	59.19	8.46	37.68	44.50	60.83	74	-13.17	PK
V	11650.030	43.40	8.46	37.68	44.50	45.04	54	-8.96	AV
V	17475.079	57.06	10.12	38.80	44.10	61.88	68.2	-6.32	PK
V	17475.079	43.39	10.12	38.80	42.70	49.61	54	-4.39	AV
H	6039.178	56.45	7.10	37.24	43.50	57.29	68.2	-10.91	PK
H	6039.178	43.99	7.10	37.24	43.50	44.83	54	-9.17	AV
H	11650.103	51.32	8.46	38.57	44.50	53.85	74	-20.15	PK
H	11650.103	41.67	8.46	38.57	44.50	44.20	54	-9.80	AV
H	17475.069	51.13	10.12	38.38	44.10	55.53	68.2	-12.67	PK
H	17475.069	42.51	10.12	38.38	44.10	46.91	54	-7.09	AV

Note: PK value is lower than the Average value limit, So average didn't record.
 The 26.5-40G amplitude of spurious emissions that are attenuated by more than 20dB below the permissible value has no need to be reported.
 Emission level (dBuV/m) = 20 log Emission level (uV/m).
 Corrected Reading: Antenna Factor + Cable Loss + Read Level - Preamp Factor = Level.
 The worst case is Antenna A.



Test Mode:	TX(5.8G) - 802.11n-HT20
------------	-------------------------

Polar (H/V)	Frequency	Meter Reading	Cable loss	Antenna Factor	Preamp Factor	Emission Level	Limits	Margin	Detector Type
	(MHz)	(dBuV)	(dB)	dB/m	(dB)	(dBuV/m)	(dBuV/m)	(dB)	
Low Channel (5745 MHz)-Above 1G									
V	4679.101	60.50	5.94	35.40	44.00	57.84	74	-16.16	PK
V	4679.101	43.42	5.94	35.40	44.00	40.76	54	-13.24	AV
V	11490.082	53.40	8.46	39.75	44.50	57.11	68.2	-11.09	PK
V	11490.082	43.75	8.46	39.75	44.50	47.46	54	-6.54	AV
V	17235.182	59.22	10.12	38.80	44.10	64.04	68.2	-4.16	PK
V	17235.182	43.71	10.12	38.80	42.70	49.93	54	-4.07	AV
H	4679.040	56.11	5.94	35.18	44.00	53.23	74	-20.77	PK
H	4679.040	43.43	5.94	35.18	44.00	40.55	54	-13.45	AV
H	11490.132	50.35	8.46	38.71	44.50	53.02	68.2	-15.18	PK
H	11490.132	43.75	8.46	38.71	44.50	46.42	54	-7.58	AV
H	17235.184	51.52	10.12	38.38	44.10	55.92	68.2	-12.28	PK
H	17235.184	42.34	10.12	38.38	44.10	46.74	54	-7.26	AV
Middle Channel (5785 MHz)-Above 1G									
V	4592.155	62.70	6.48	36.35	44.05	61.48	74	-12.52	PK
V	4592.155	43.47	6.48	36.35	44.05	42.25	54	-11.75	AV
V	11570.153	54.93	8.47	37.88	44.51	56.77	68.2	-11.43	PK
V	11570.153	43.30	8.47	37.88	44.51	45.14	54	-8.86	AV
V	17355.179	60.56	10.12	38.80	44.10	65.38	68.2	-2.82	PK
V	17355.179	43.90	10.12	38.80	42.70	50.12	54	-3.88	AV
H	4592.048	56.38	6.48	36.37	44.05	55.18	74	-18.82	PK
H	4592.048	43.56	6.48	36.37	44.05	42.36	54	-11.64	AV
H	11570.199	51.17	8.47	38.64	44.50	53.78	68.2	-14.42	PK
H	11570.199	41.63	8.47	38.64	44.50	44.24	54	-9.76	AV
H	17355.164	54.47	10.12	38.38	44.10	58.87	68.2	-9.33	PK
H	17355.164	43.86	10.12	38.38	44.10	48.26	54	-5.74	AV
High Channel (5825 MHz)-Above 1G									
V	6039.199	59.33	7.10	37.24	43.50	60.17	68.2	-8.03	PK
V	6039.199	43.39	7.10	37.24	43.50	44.23	54	-9.77	AV
V	11650.118	58.30	8.46	37.68	44.50	59.94	74	-14.06	PK
V	11650.118	43.17	8.46	37.68	44.50	44.81	54	-9.19	AV
V	17475.010	55.32	10.12	38.80	44.10	60.14	68.2	-8.06	PK
V	17475.010	43.63	10.12	38.80	42.70	49.85	54	-4.15	AV
H	6039.190	57.19	7.10	37.24	43.50	58.03	68.2	-10.17	PK
H	6039.190	43.32	7.10	37.24	43.50	44.16	54	-9.84	AV
H	11650.031	50.37	8.46	38.57	44.50	52.90	74	-21.10	PK
H	11650.031	40.31	8.46	38.57	44.50	42.84	54	-11.16	AV
H	17475.019	52.52	10.12	38.38	44.10	56.92	68.2	-11.28	PK
H	17475.019	44.48	10.12	38.38	44.10	48.88	54	-5.12	AV

Note: PK value is lower than the Average value limit, So average didn't record.
 The 26.5-40G amplitude of spurious emissions that are attenuated by more than 20dB below the permissible value has no need to be reported.
 Emission level (dBuV/m) = 20 log Emission level (uV/m).
 Corrected Reading: Antenna Factor + Cable Loss + Read Level - Preamp Factor = Level.
 Test Mode is MIMO Mode.

CO.LTD

Test Mode:	TX(5.8G) - 802.11n-HT40
------------	-------------------------

Polar (H/V)	Frequency	Meter Reading	Cable loss	Antenna Factor	Preamp Factor	Emission Level	Limits	Margin	Detector Type
	(MHz)	(dBuV)	(dB)	dB/m	(dB)	(dBuV/m)	(dBuV/m)	(dB)	
Low Channel (5755 MHz)-Above 1G									
V	4679.058	56.06	5.94	35.40	44.00	53.40	74	-20.60	PK
V	4679.058	43.67	5.94	35.40	44.00	41.01	54	-12.99	AV
V	11510.020	56.70	8.46	39.75	44.50	60.41	74	-13.59	PK
V	11510.020	43.34	8.46	39.75	44.50	47.05	54	-6.95	AV
V	17265.018	58.13	10.12	38.80	44.10	62.95	68.2	-5.25	PK
V	17265.018	2.00	10.12	38.80	42.70	8.22	54	-45.78	AV
H	4679.043	57.35	5.94	35.18	44.00	54.47	74	-19.53	PK
H	4679.043	43.99	5.94	35.18	44.00	41.11	54	-12.89	AV
H	11510.019	50.43	8.46	38.71	44.50	53.10	74	-20.90	PK
H	11510.019	43.99	8.46	38.71	44.50	46.66	54	-7.34	AV
H	17265.010	50.88	10.12	38.38	44.10	55.28	68.2	-12.92	PK
H	17265.010	41.84	10.12	38.38	44.10	46.24	54	-7.76	AV
High Channel (5795 MHz)-Above 1G									
V	6039.084	57.72	6.48	36.35	44.05	56.50	68.2	-11.70	PK
V	6039.084	43.93	6.48	36.35	44.05	42.71	54	-11.29	AV
V	11590.036	56.14	8.47	37.88	44.51	57.98	74	-16.02	PK
V	11590.036	43.82	8.47	37.88	44.51	45.66	54	-8.34	AV
V	17385.099	55.70	10.12	38.80	44.10	60.52	68.2	-7.68	PK
V	17385.099	41.75	10.12	38.80	42.70	47.97	54	-6.03	AV
H	6039.112	60.55	6.48	36.37	44.05	59.35	68.2	-8.85	PK
H	6039.112	43.81	6.48	36.37	44.05	42.61	54	-11.39	AV
H	11590.183	53.46	8.47	38.64	44.50	56.07	74	-17.93	PK
H	11590.183	42.21	8.47	38.64	44.50	44.82	54	-9.18	AV
H	17385.186	53.84	10.12	38.38	44.10	58.24	68.2	-9.96	PK
H	17385.186	44.78	10.12	38.38	44.10	49.18	54	-4.82	AV

Note: PK value is lower than the Average value limit, So average didn't record.

The 26.5-40G amplitude of spurious emissions that are attenuated by more than 20dB below the permissible value has no need to be reported.

Emission level (dBuV/m) = 20 log Emission level (uV/m).

Corrected Reading: Antenna Factor + Cable Loss + Read Level - Preamp Factor = Level.

Test Mode is MIMO Mode.



8. Power Spectral Density Test

8.1 Block Diagram Of Test Setup



8.2 Limit

For the band 5.15-5.25 GHz,

(i) For an outdoor Wifi Repeater operating in the band 5.15-5.25 GHz, the maximum power spectral density shall not exceed 17 dBm in any 1 megahertz band. If transmitting antennas of directional gain greater than 6 dBi are used, both the maximum conducted output power and the maximum power spectral density shall be reduced by the amount in dB that the directional gain of the antenna exceeds 6 dBi. The maximum e.i.r.p. at any elevation angle above 30 degrees as measured from the horizon must not exceed 125 mW (21 dBm).

(ii) For an indoor Wifi Repeater operating in the band 5.15-5.25 GHz, the maximum power spectral density shall not exceed 17 dBm in any 1 megahertz band. If transmitting antennas of directional gain greater than 6 dBi are used, both the maximum conducted output power and the maximum power spectral density shall be reduced by the amount in dB that the directional gain of the antenna exceeds 6 dBi.

(iii) For fixed point-to-point Wifi Repeaters operating in the band 5.15-5.25 GHz, the maximum power spectral density shall not exceed 17 dBm in any 1 megahertz band. Fixed point-to-point U-NII devices may employ antennas with directional gain up to 23 dBi without any corresponding reduction in the maximum conducted output power or maximum power spectral density. For fixed point-to-point transmitters that employ a directional antenna gain greater than 23 dBi, a 1 dB reduction in maximum conducted output power and maximum power spectral density is required for each 1 dB of antenna gain in excess of 23 dBi. Fixed, point-to-point operations exclude the use of point-to-multipoint systems, omnidirectional applications, and multiple collocated transmitters transmitting the same information. The operator of the U-NII device, or if the equipment is professionally installed, the installer, is responsible for ensuring that systems employing high gain directional antennas are used exclusively for fixed, point-to-point operations.

(iv) For client devices in the 5.15-5.25 GHz band, the maximum power spectral density shall not exceed 11 dBm in any 1 megahertz band. If transmitting antennas of directional gain greater than 6 dBi are used, both the maximum conducted output power and the maximum power spectral density shall be reduced by the amount in dB that the directional gain of the antenna exceeds 6 dBi.

For the band 5.725-5.85 GHz

(3) For the band 5.725-5.85 GHz, the maximum power spectral density shall not exceed 30 dBm in any 500-kHz band. If transmitting antennas of directional gain greater than 6 dBi are used, both the maximum conducted output power and the maximum power spectral density shall be reduced by the amount in dB that the directional gain of the antenna exceeds 6 dBi.



8.3 Test procedure

For devices operating in the bands 5.15-5.25 GHz, 5.25-5.35 GHz, and 5.47-5.725 GHz, the above procedures make use of 1 MHz RBW to satisfy directly the 1 MHz reference bandwidth specified in § 15.407(a)(5). For devices operating in the band 5.725-5.85 GHz, the rules specify a measurement bandwidth of 500 kHz. Many spectrum analyzers do not have 500 kHz RBW, thus a narrower RBW may need to be used. The rules permit the use of a RBWs less than 1 MHz, or 500 kHz, “provided that the measured power is integrated over the full reference bandwidth” to show the total power over the specified measurement bandwidth (i.e., 1 MHz, or 500 kHz). If measurements are performed using a reduced resolution bandwidth (< 1 MHz, or < 500 kHz) and integrated over 1 MHz, or 500 KHz bandwidth, the following adjustments to the procedures apply:

- a) Set $RBW \geq 1/T$, where T is defined in section II.B.I.a).
- b) Set $VBW \geq 3 RBW$.
- c) If measurement bandwidth of Maximum PSD is specified in 500 kHz, add $10\log(500\text{kHz}/RBW)$ to the measured result, whereas RBW (< 500 KHz) is the reduced resolution bandwidth of the spectrum analyzer set during measurement.
- d) If measurement bandwidth of Maximum PSD is specified in 1 MHz, add $10\log(1\text{MHz}/RBW)$ to the measured result, whereas RBW (< 1 MHz) is the reduced resolution bandwidth of spectrum analyzer set during measurement.
- e) Care must be taken to ensure that the measurements are performed during a period of continuous transmission or are corrected upward for duty cycle.

Note: As a practical matter, it is recommended to use reduced RBW of 100 KHz for the sections 5.c) and 5.d) above, since RBW=100 KHZ is available on nearly all spectrum analyzers.

8.4 EUT operating Conditions

The EUT was configured for testing in a typical fashion (as a customer would normally use it). The EUT has been programmed to continuously transmit during test. This operating condition was tested and used to collect the included data.

8.5 Test Result

Temperature:	26 °C	Relative Humidity:	54%
Pressure:	101KPa	Test Voltage:	DC 11.1V
Test Mode:	TX Frequency U-NII-3 (5745-5825MHz)		

Condition	Mode	Frequency (MHz)	Conducted PSD (dBm)		Total (dBm)	Limit (dBm)	Verdict
			Ant A	Ant B			
NVNT	a	5745	0.89	2.91	/	30	Pass
NVNT	a	5785	0.96	0.88	/	30	Pass
NVNT	a	5825	0.67	-0.27	/	30	Pass
NVNT	n20	5745	0.18	1.05	3.65	30	Pass
NVNT	n20	5785	-0.77	-1.27	2.00	30	Pass
NVNT	n20	5825	-0.38	-2.27	1.79	30	Pass
NVNT	n40	5755	-4.15	-2.81	-0.42	30	Pass
NVNT	n40	5795	-5.11	-5.11	-2.10	30	Pass

TEST
 TO
 OVER
 檢

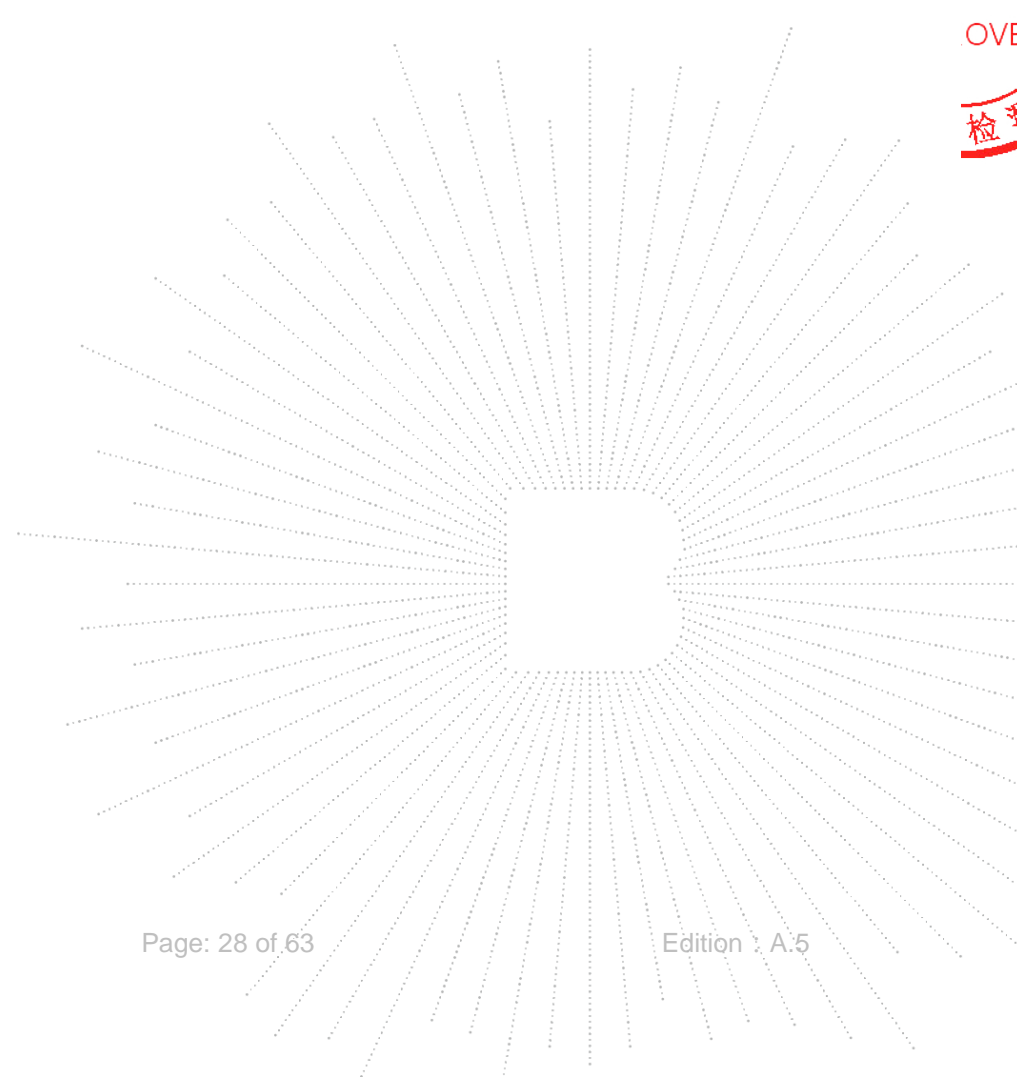

Note: A(B) Represent the value of antenna A and B, The worst data is Antenna B, only shown Antenna B Plot.

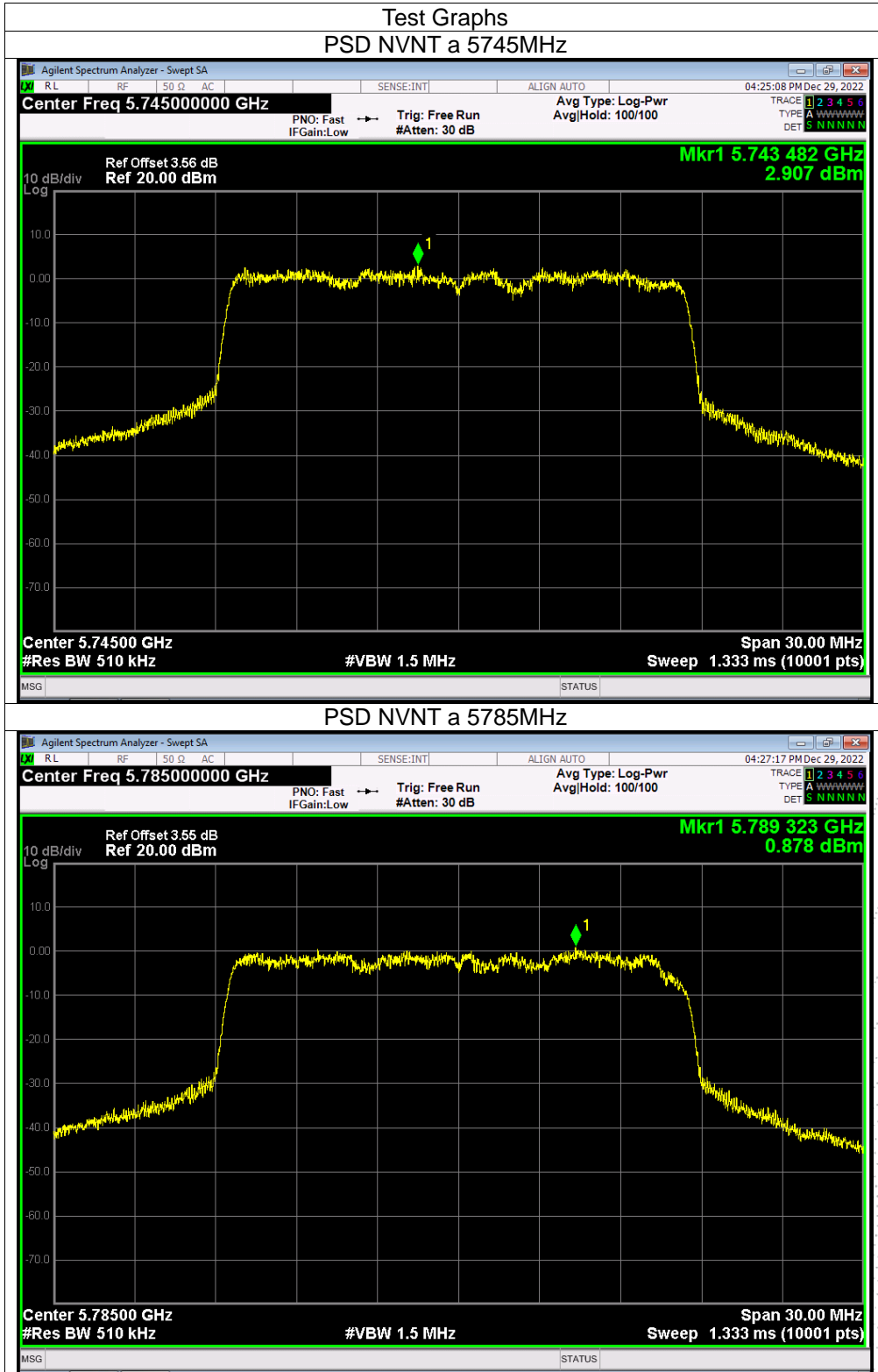

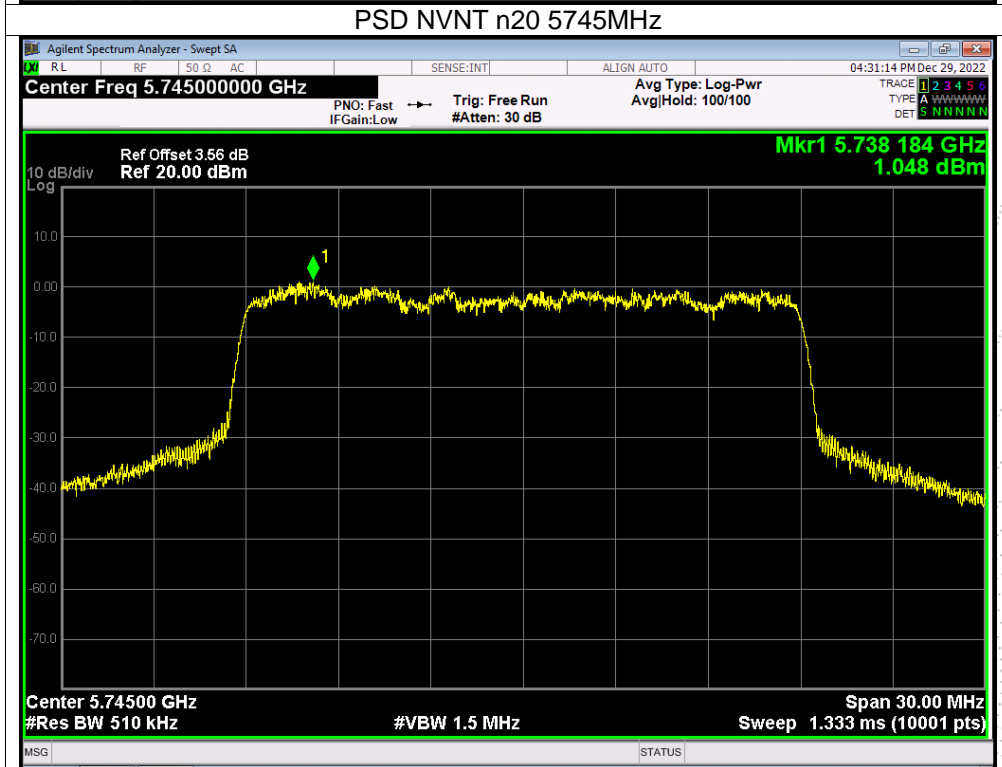
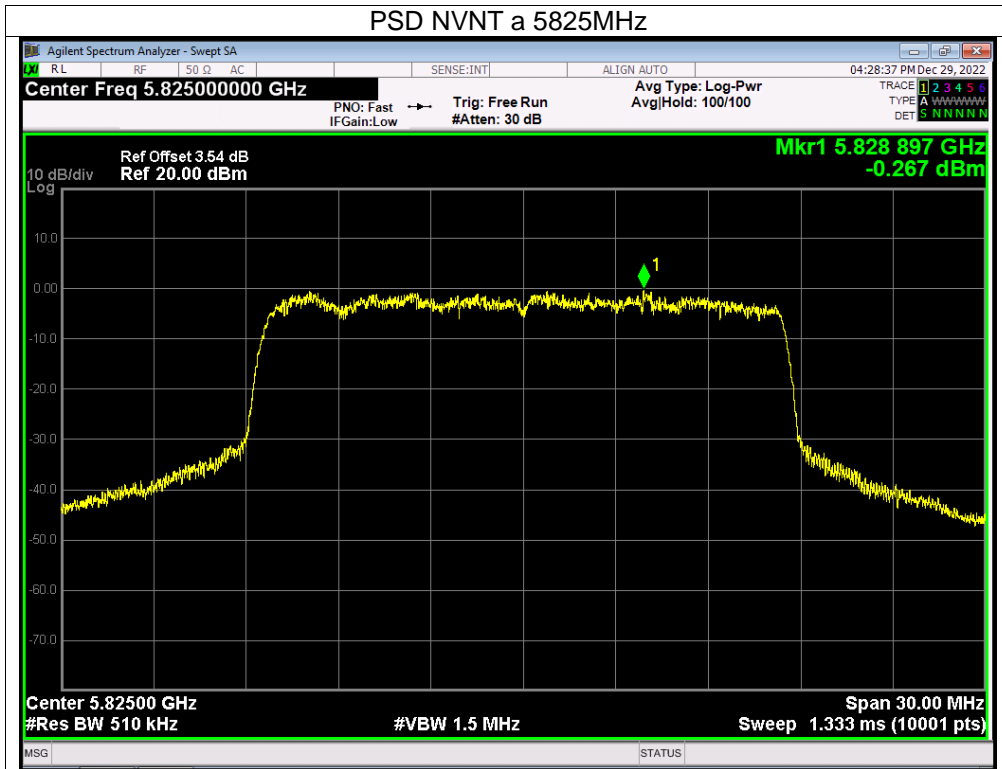

CO., LTD

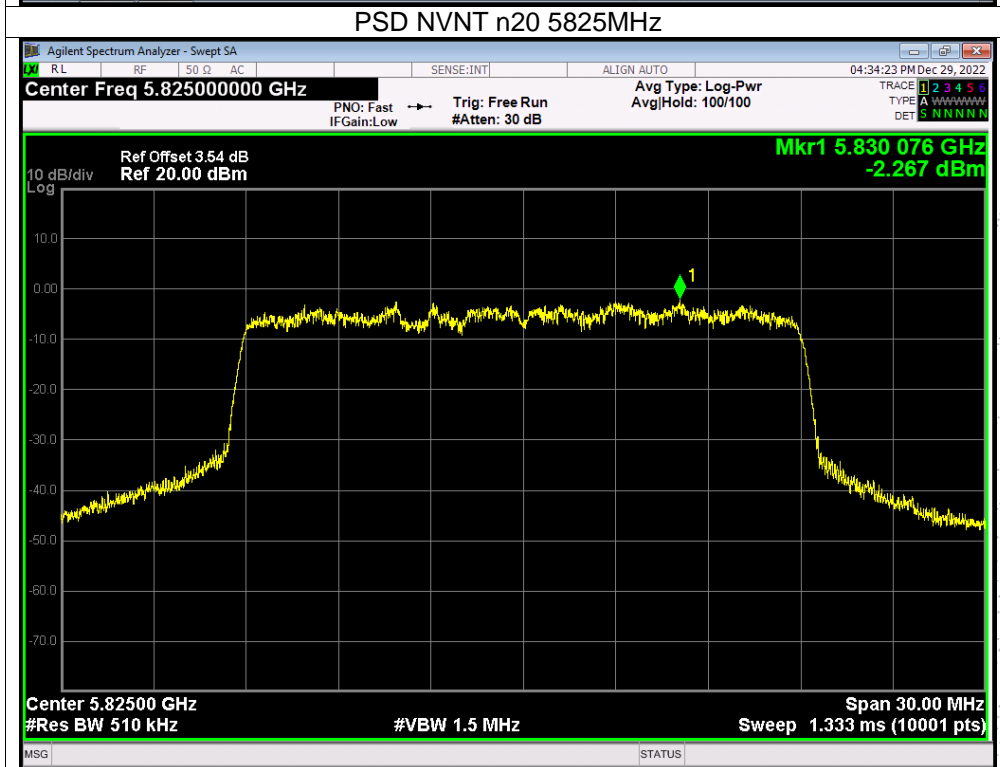
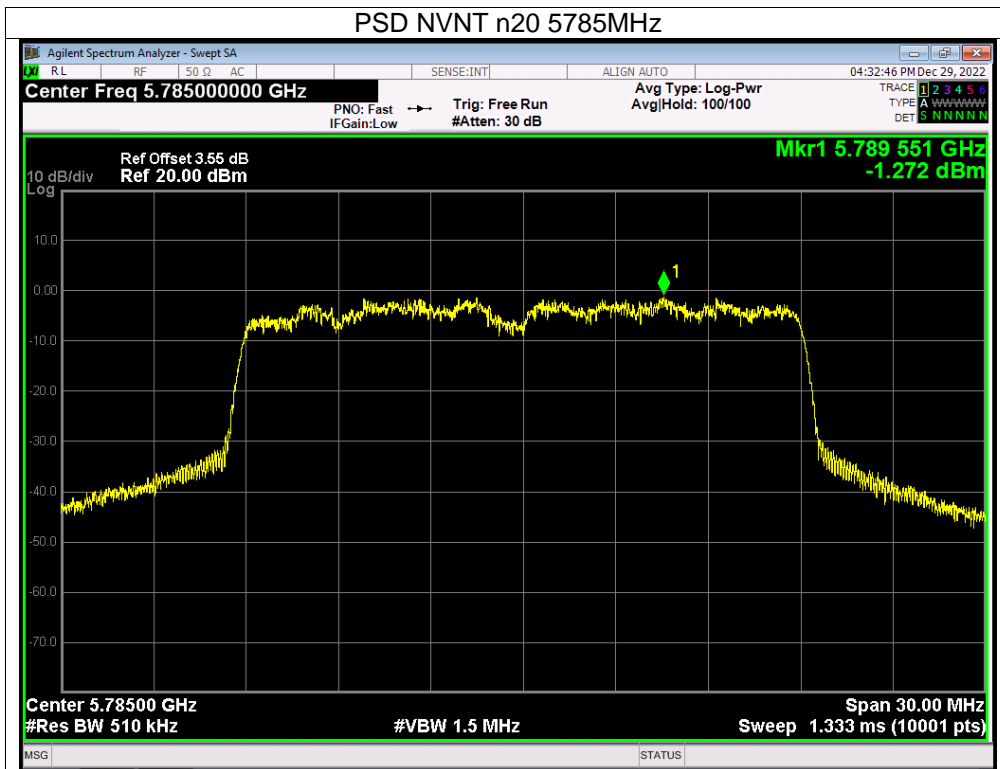

SHENZHEN

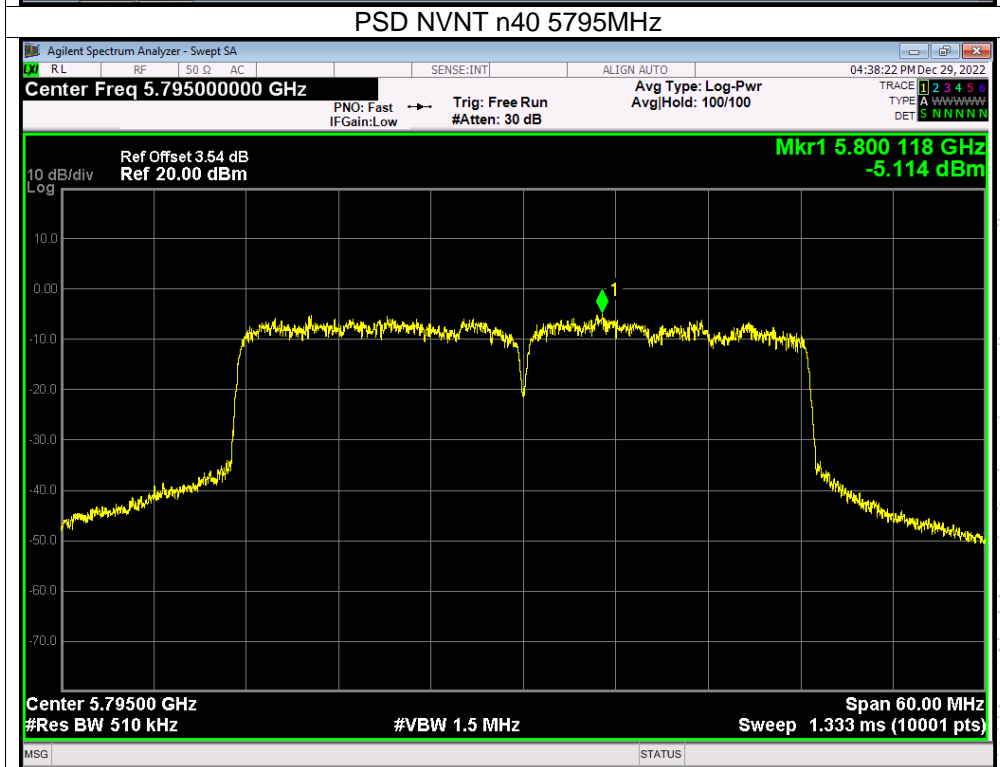
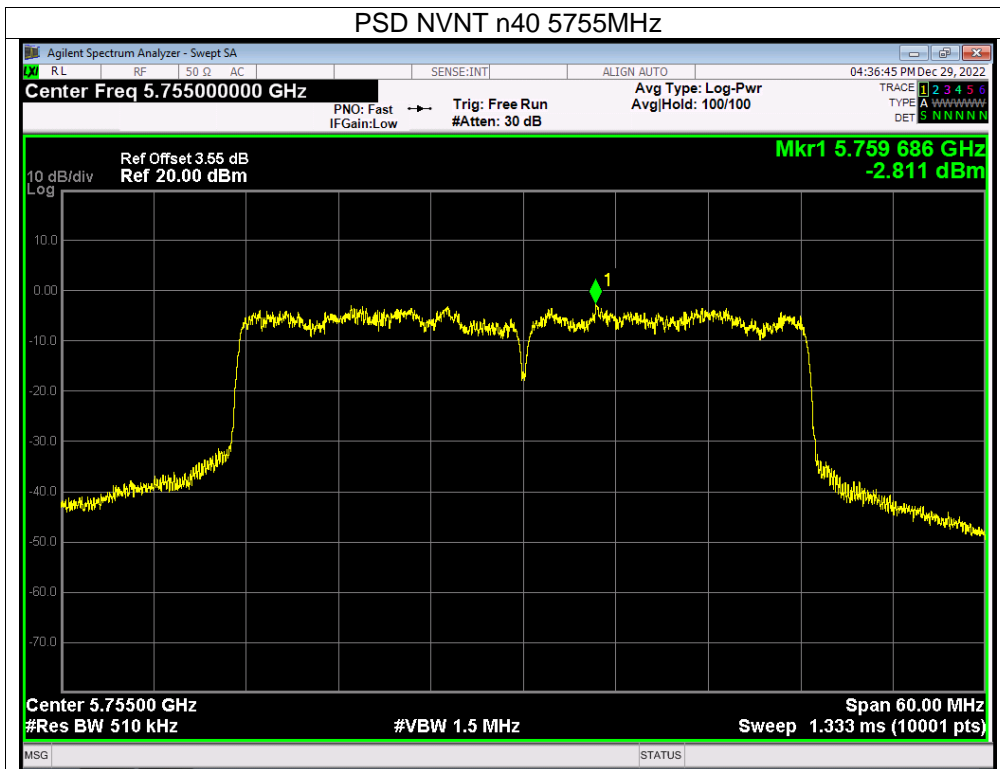

9. 26dB & 6dB & 99% Emission Bandwidth

9.1 Block Diagram Of Test Setup

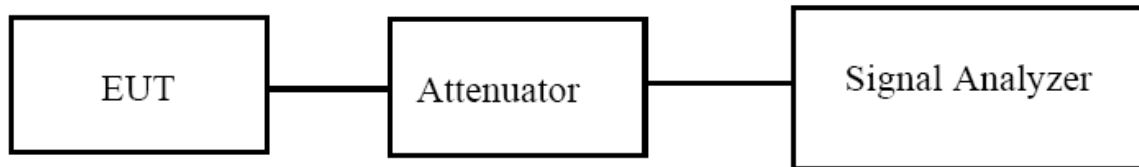

9.2 Limit

The maximum power spectral density is measured as a conducted emission by direct connection of a calibrated test instrument to the equipment under test. If the device cannot be connected directly, alternative techniques acceptable to the Commission may be used. Measurements in the 5.725-5.85 GHz band are made over a reference bandwidth of 500 kHz or the 26 dB emission bandwidth of the device, whichever is less. Measurements in the 5.15-5.25 GHz, 5.25-5.35 GHz, and the 5.47-5.725 GHz bands are made over a bandwidth of 1 MHz or the 26 dB emission bandwidth of the device, whichever is less. A narrower resolution bandwidth can be used, provided that the measured power is integrated over the full reference bandwidth.

9.3 Test procedure

- a) Set RBW = approximately 1% of the emission bandwidth.
- b) Set the VBW > RBW.
- c) Detector = Peak.
- d) Trace mode = max hold.
- e) Measure the maximum width of the emission that is 26 dB down from the maximum of the emission. Compare this with the RBW setting of the analyzer. Readjust RBW and repeat measurement as needed until the RBW/EBW ratio is approximately 1%.
The following procedure shall be used for measuring (99 %) power bandwidth:
 1. Set center frequency to the nominal EUT channel center frequency.
 2. Set span = 1.5 times to 5.0 times the OBW.
 3. Set RBW = 1 % to 5 % of the OBW
 4. Set VBW $\geq 3 \cdot$ RBW
 5. Video averaging is not permitted. Where practical, a sample detection and single sweep mode shall be used. Otherwise, peak detection and max hold mode (until the trace stabilizes) shall be used.
 6. Use the 99 % power bandwidth function of the instrument (if available).
 7. If the instrument does not have a 99 % power bandwidth function, the trace data points are recovered and directly summed in power units. The recovered amplitude data points, beginning at the lowest frequency, are placed in a running sum until 0.5 % of the total is reached; that frequency is recorded as the lower frequency. The process is repeated until 99.5 % of the total is reached; that frequency is recorded as the upper frequency. The 99% occupied bandwidth is the difference between these two frequencies.

9.4 EUT operating Conditions

The EUT was configured for testing in a typical fashion (as a customer would normally use it). The EUT has been programmed to continuously transmit during test. This operating condition was tested and used to collect the included data.

9.5 Test Result

Temperature:	26 °C	Relative Humidity:	54%
Pressure:	101KPa	Test Voltage:	DC 11.1V
Test Mode:	TX Frequency U-NII-3 (5745-5825MHz)		

Condition	Mode	Frequency (MHz)	-6 dB Bandwidth (MHz)		Limit -6 dB Bandwidth (MHz)	Verdict
			Ant A	Ant B		
NVNT	a	5745	16.320	16.340	0.5	Pass
NVNT	a	5785	16.330	16.325	0.5	Pass
NVNT	a	5825	16.384	16.331	0.5	Pass
NVNT	n20	5745	17.160	17.257	0.5	Pass
NVNT	n20	5785	17.571	17.527	0.5	Pass
NVNT	n20	5825	17.136	17.257	0.5	Pass
NVNT	n40	5755	35.720	35.719	0.5	Pass
NVNT	n40	5795	35.913	35.726	0.5	Pass

Condition	Mode	Frequency (MHz)	99% OBW (MHz)	
			Ant A	Ant B
NVNT	a	5745	16.590	16.559
NVNT	a	5785	16.578	16.583
NVNT	a	5825	16.559	16.570
NVNT	n20	5745	17.682	17.702
NVNT	n20	5785	17.735	17.688
NVNT	n20	5825	17.673	17.652
NVNT	n40	5755	36.360	36.365
NVNT	n40	5795	36.280	36.313

TEST
 TO
 OVER
 檢

Note: A(B) Represent the value of antenna A and B, The worst data is Antenna B, only shown Antenna B Plot.

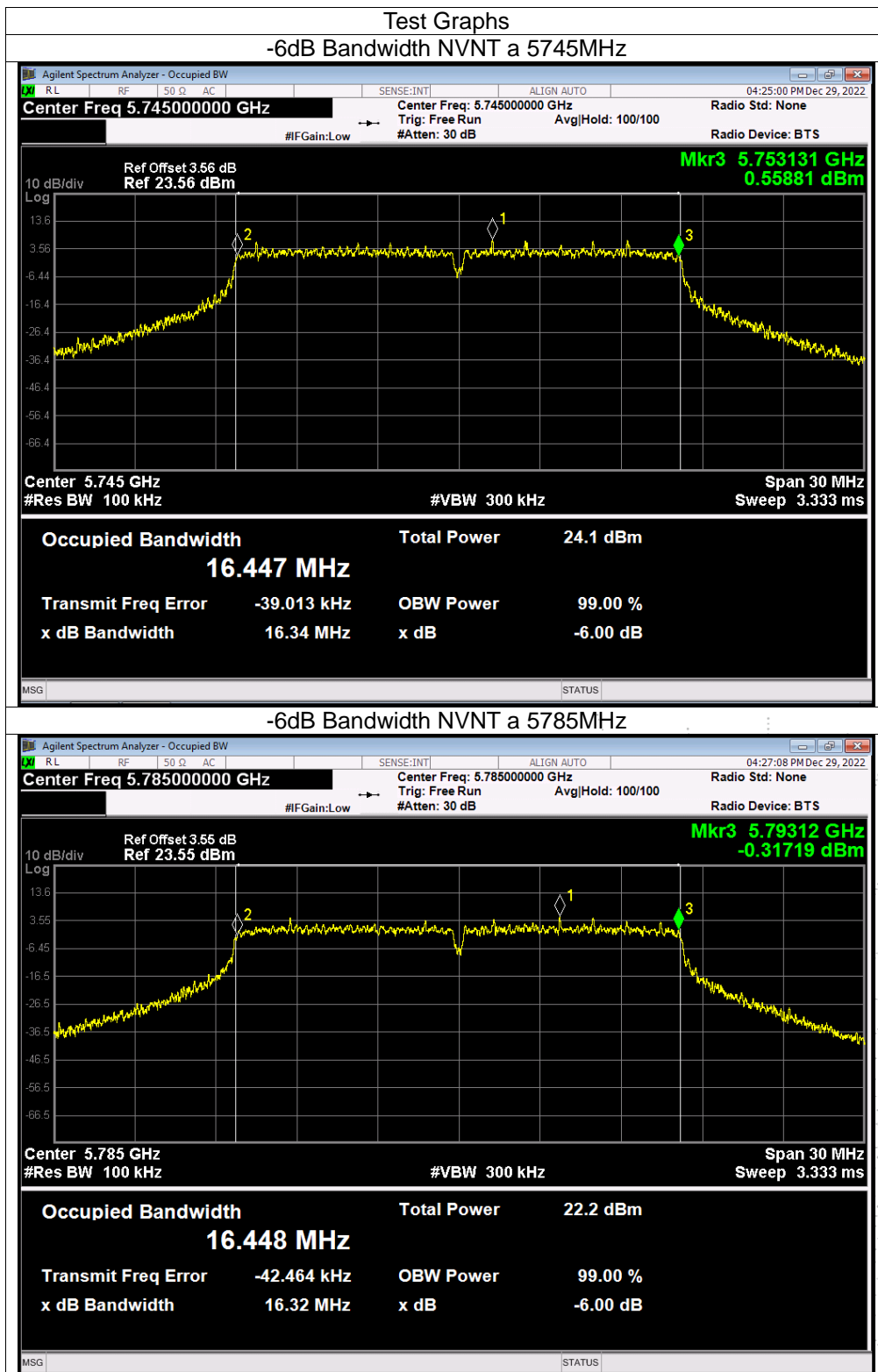

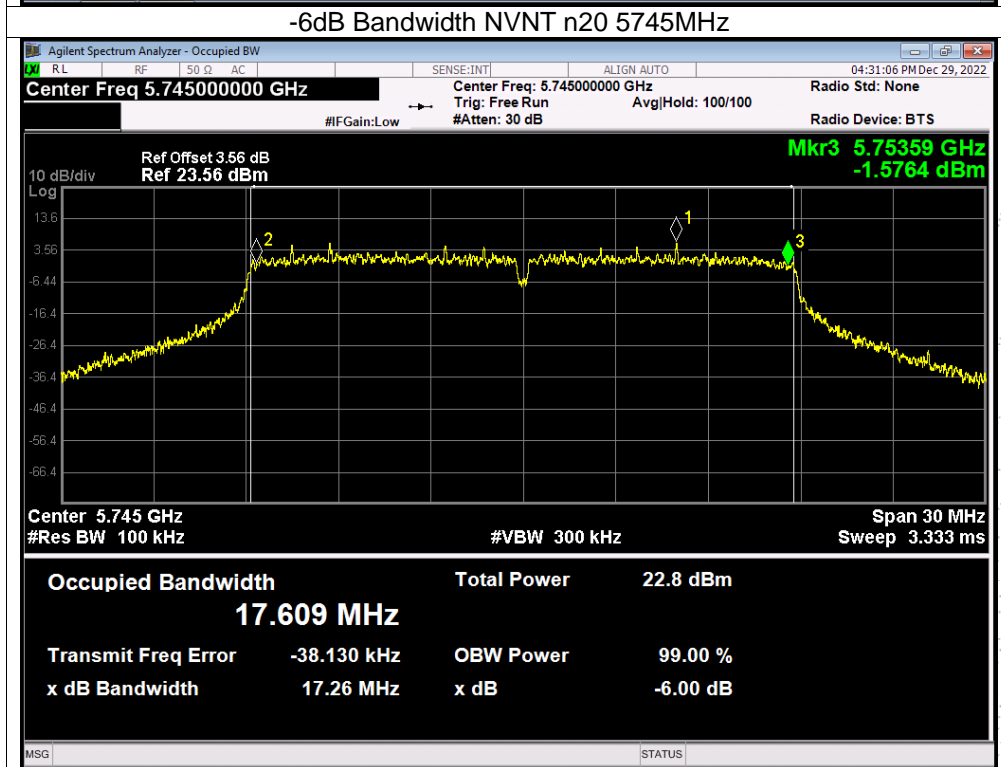
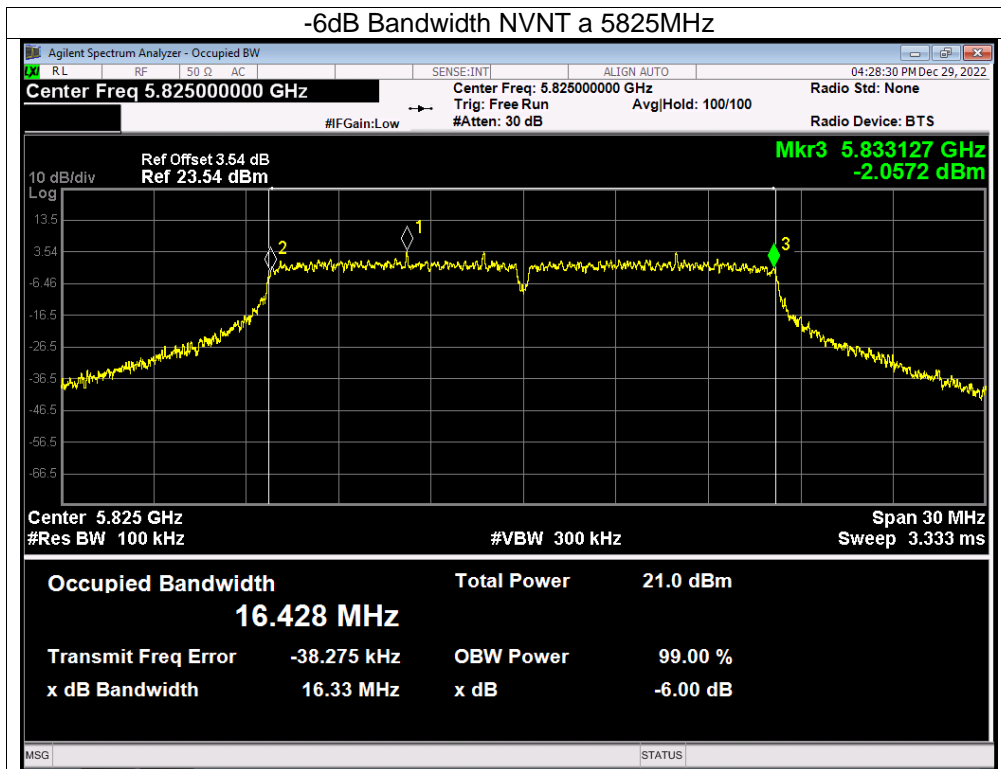

CO., LTD

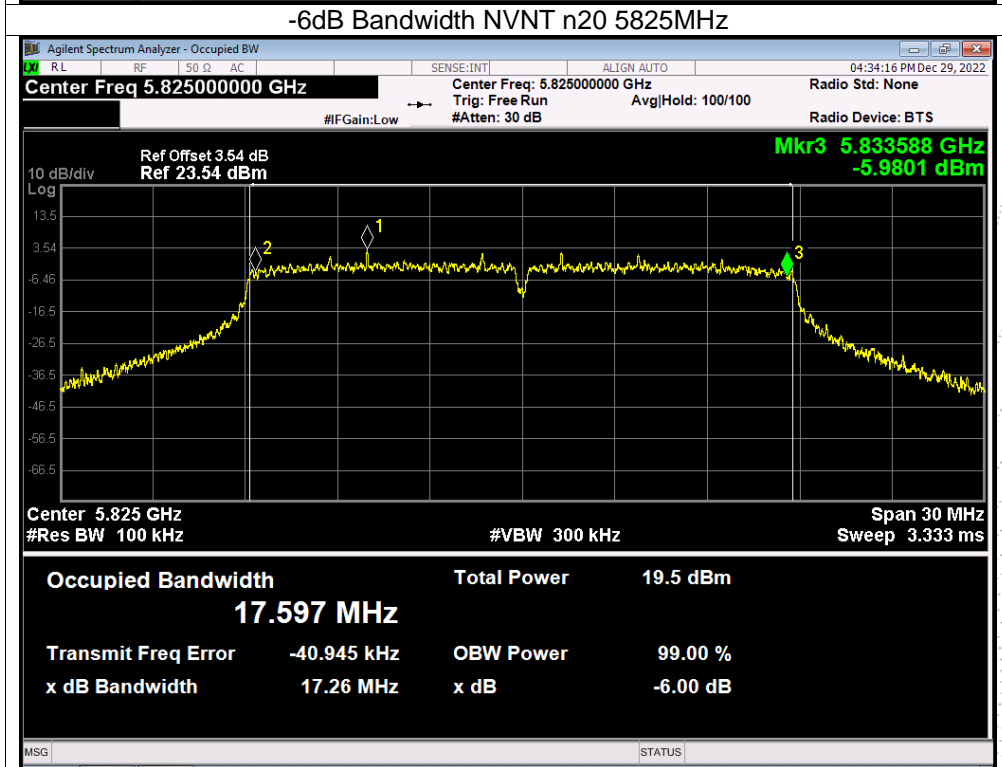
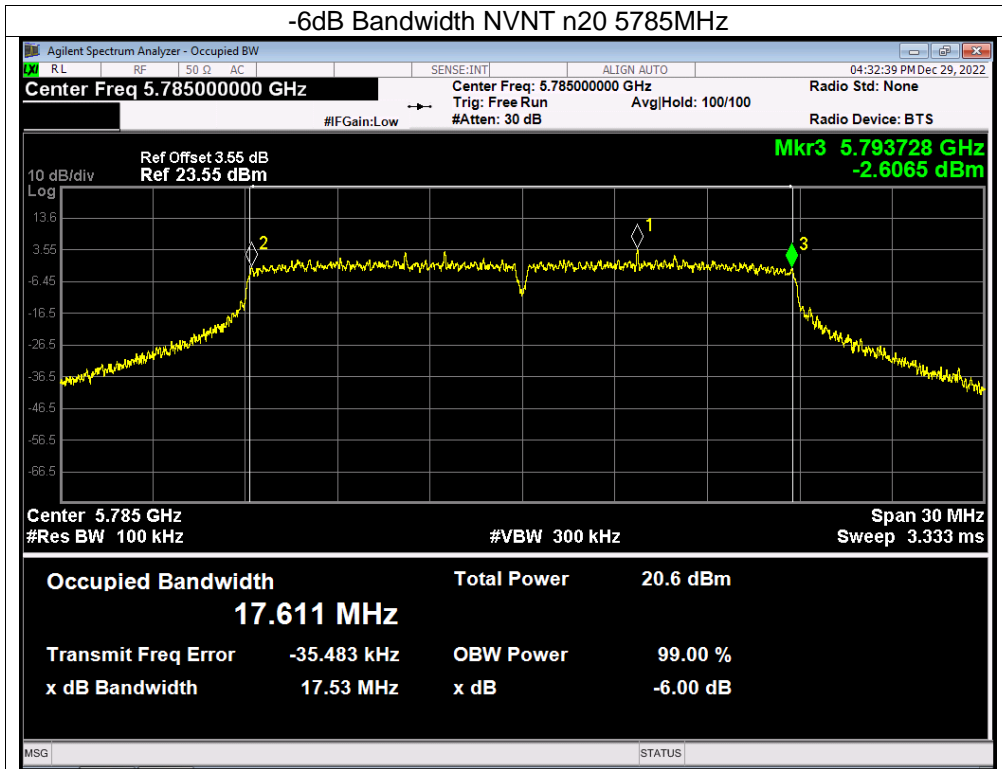

CHENZHEN

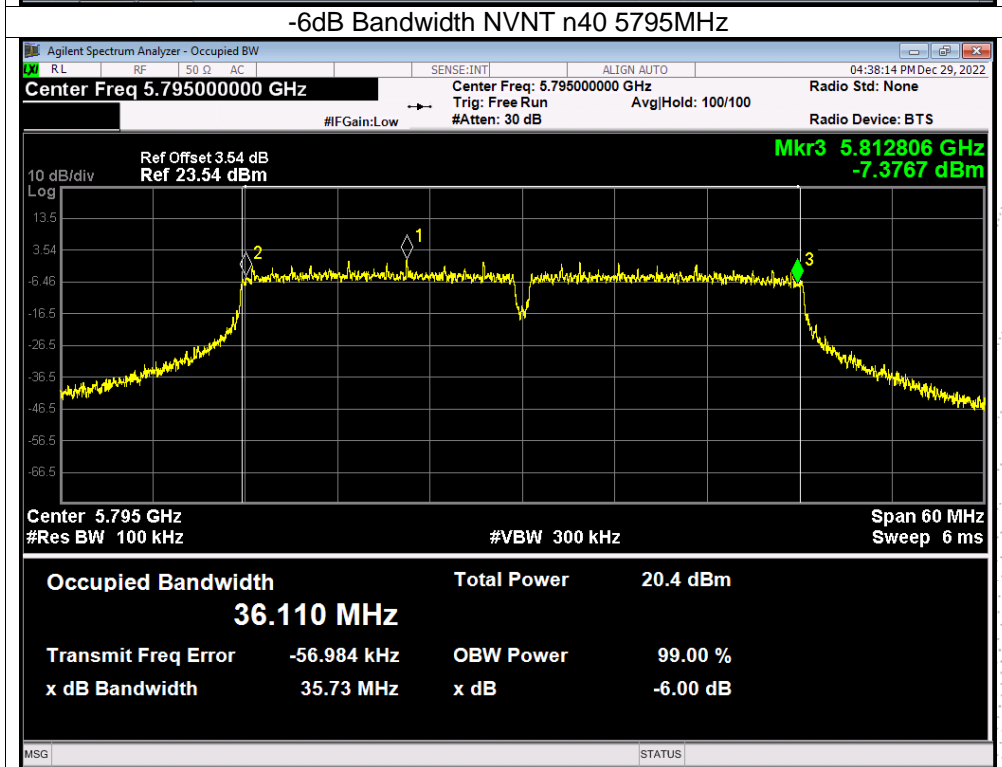
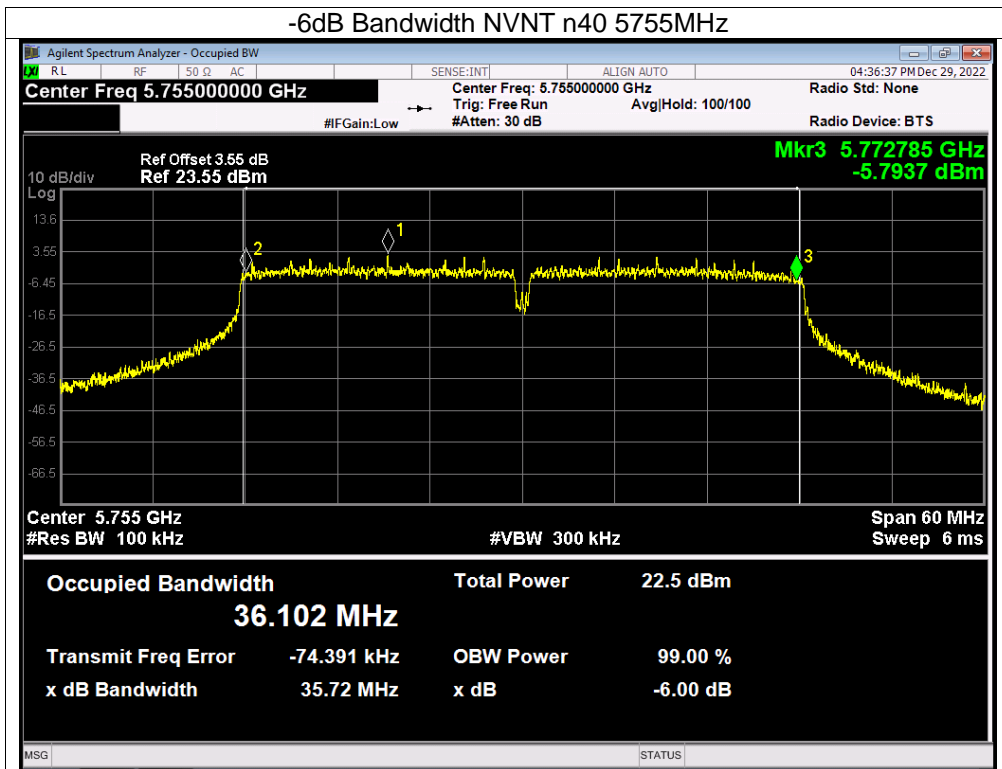

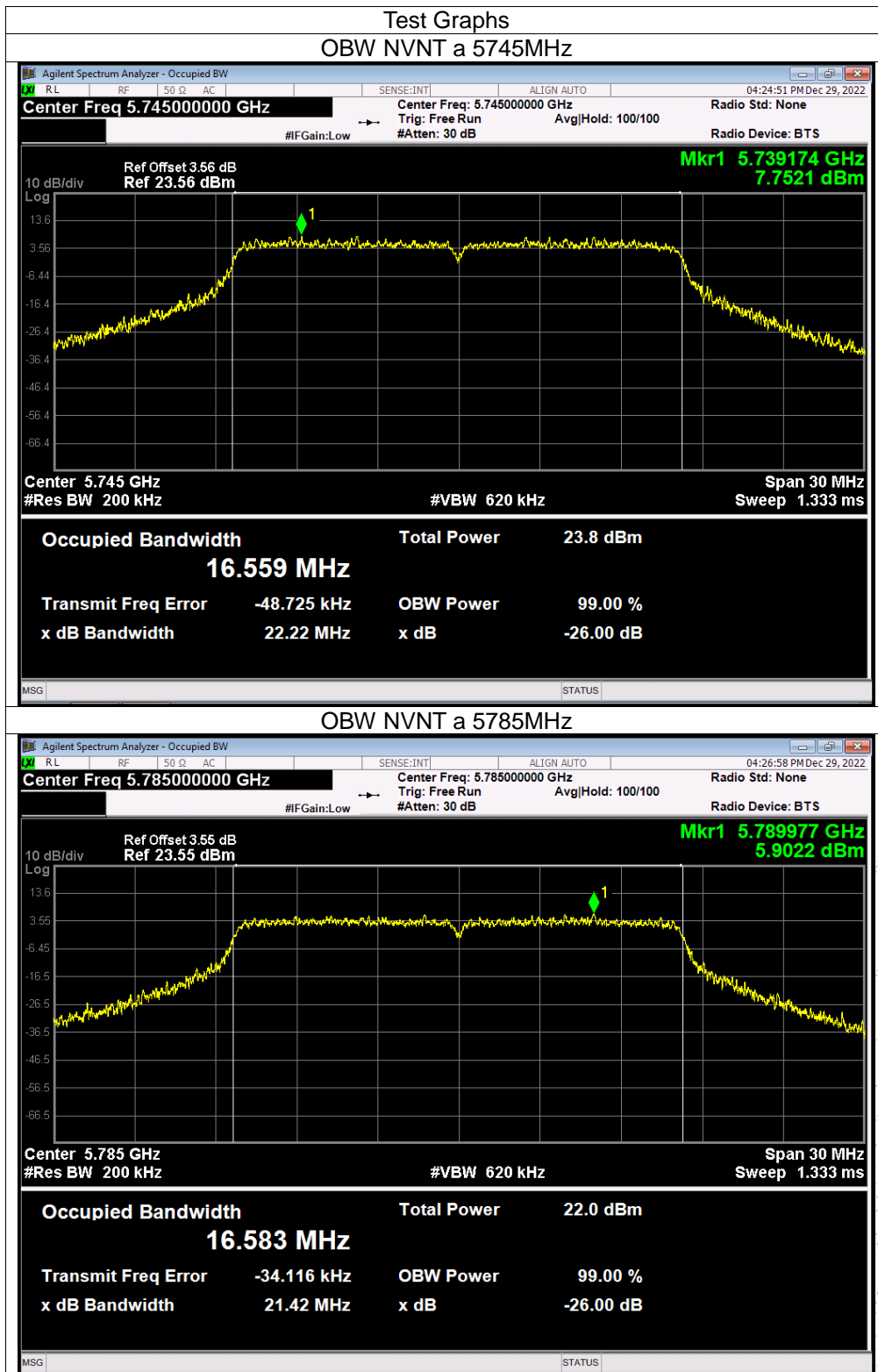

BCTC
 3C
 PPR
 本測

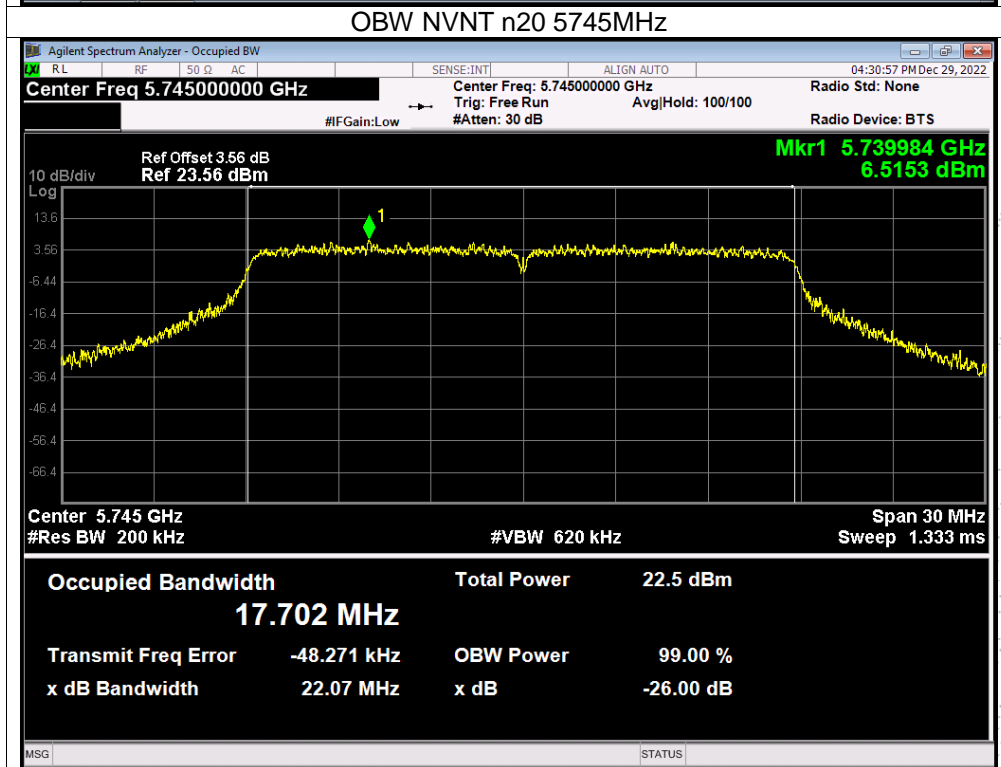
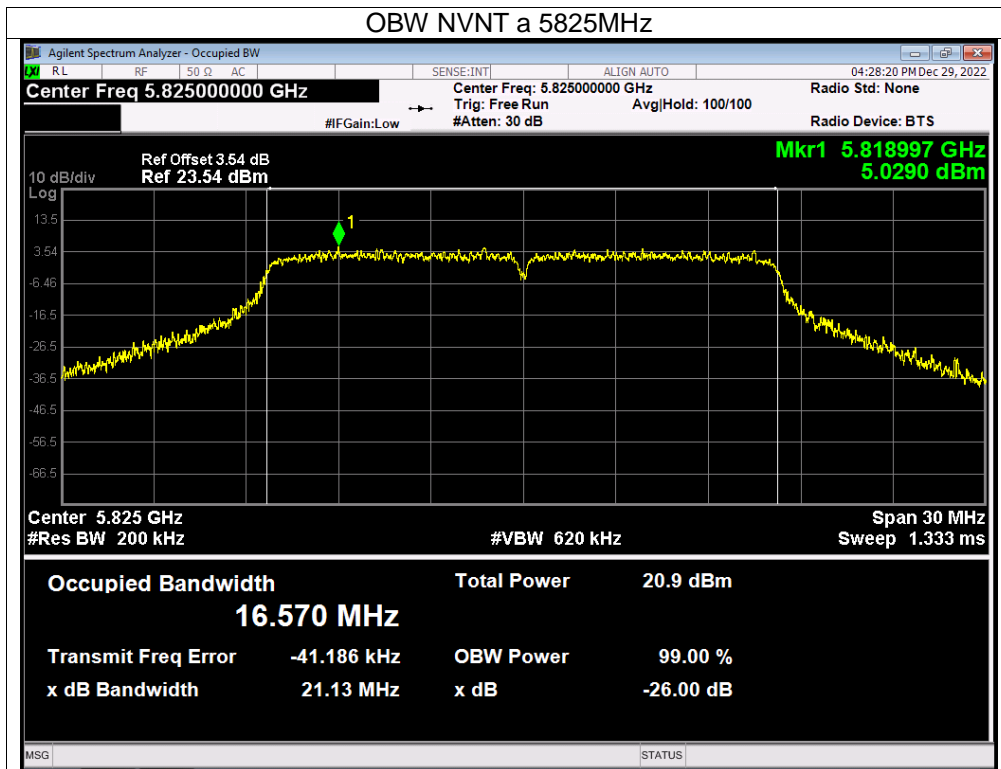

検査
 OVER
 TO
 TEST

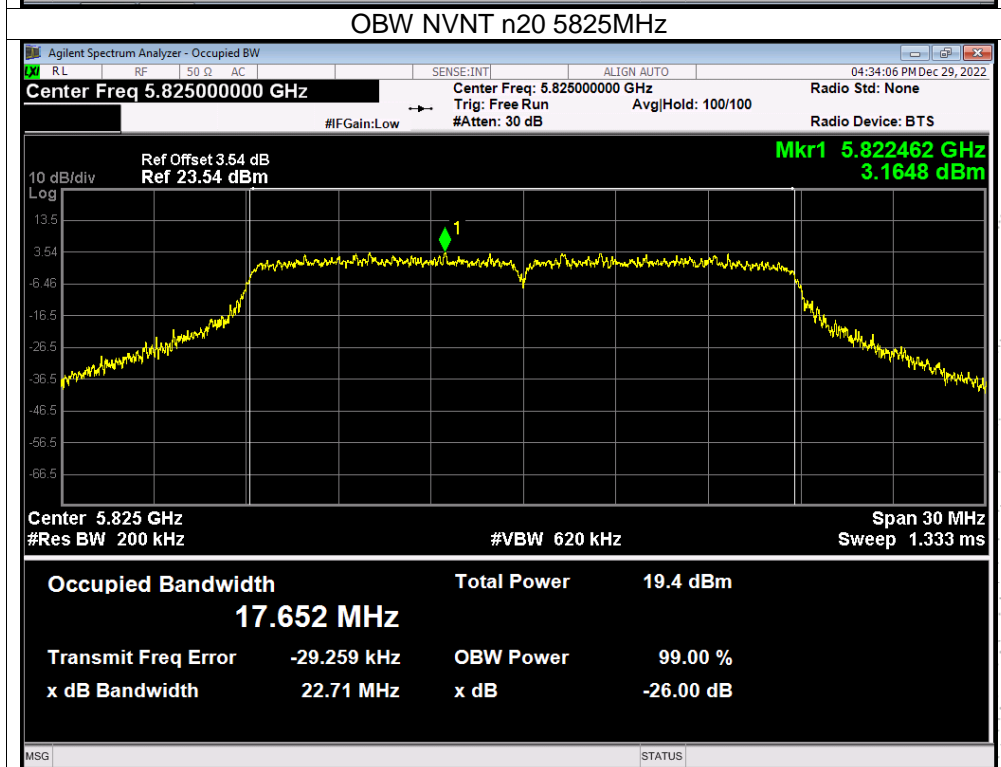
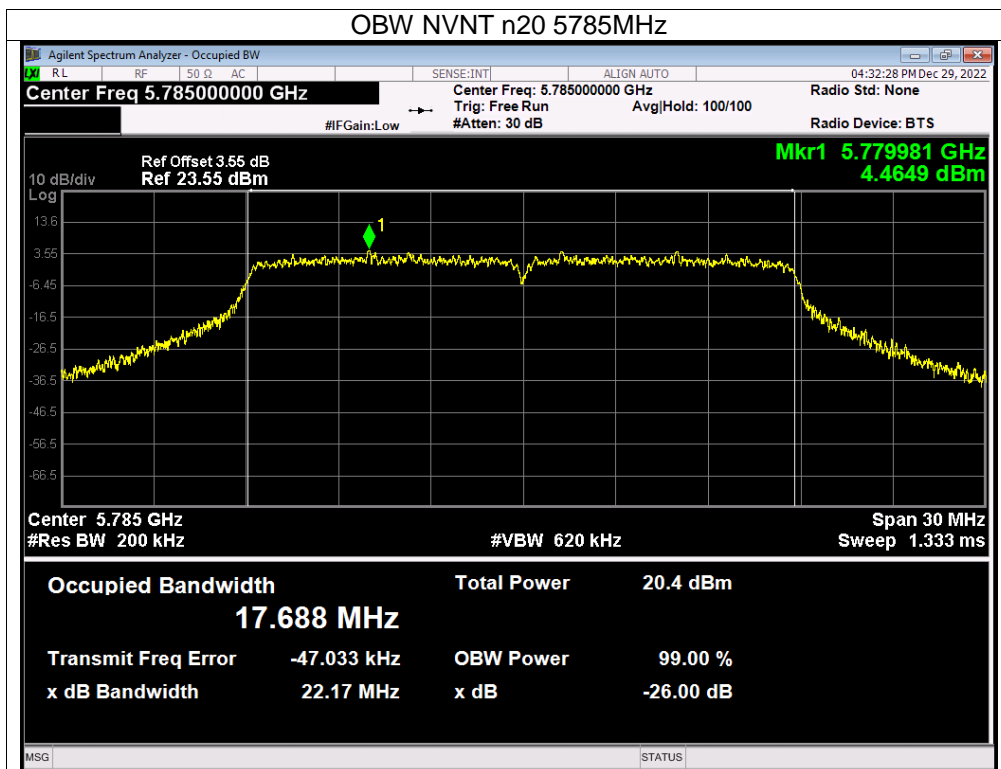

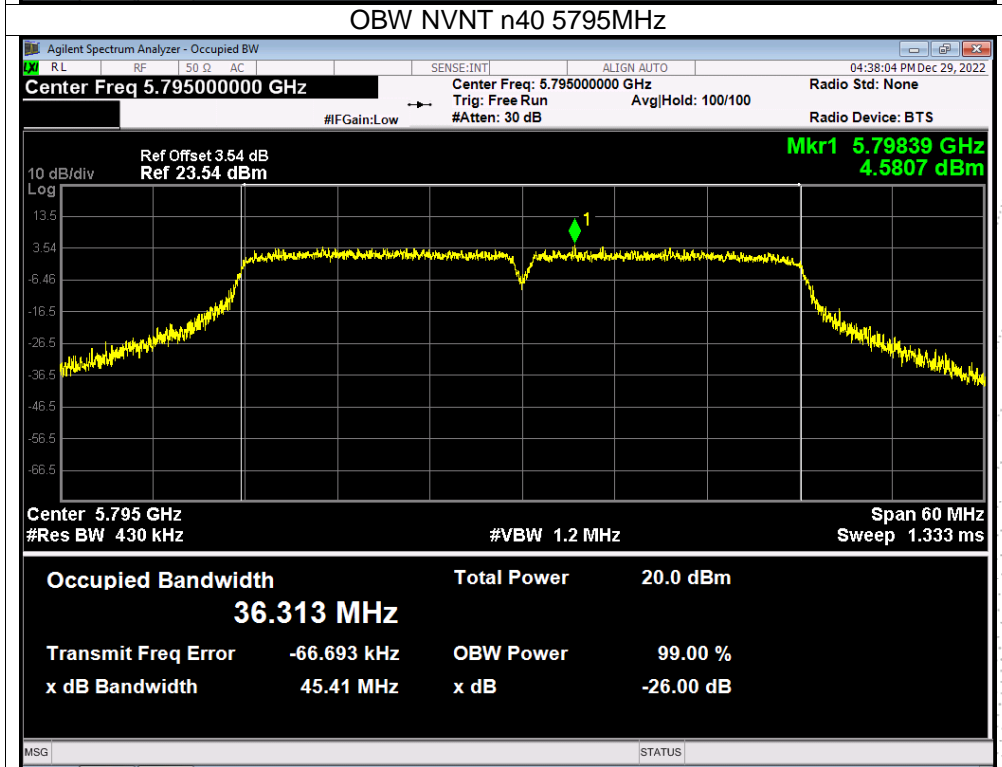
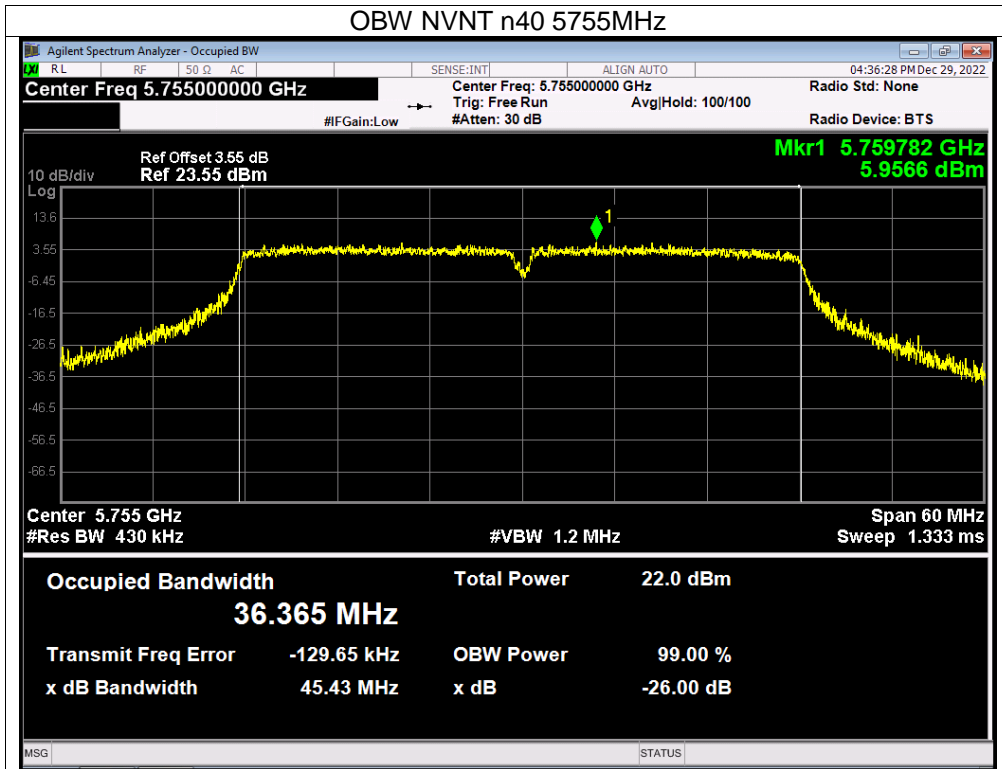

CO., LTD

10. Maximum Conducted Output Power

10.1 Block Diagram Of Test Setup



10.2 Limit

According to FCC §15.407

The maximum conducted output power should not exceed:

Frequency Band(MHz)	Limit
5150~5250	1W
5725~5850	1W

10.3 Test procedure

Maximum conducted output power may be measured using a spectrum analyzer/EMI receiver or an RF power meter.

1. Device Configuration

If possible, configure or modify the operation of the EUT so that it transmits continuously at its maximum power control level (see section II.B.).

a) The intent is to test at 100 percent duty cycle; however a small reduction in duty cycle (to no lower than 98 percent) is permitted if required by the EUT for amplitude control purposes. Manufacturers are expected to provide software to the test lab to permit such continuous operation.

b) If continuous transmission (or at least 98 percent duty cycle) cannot be achieved due to hardware limitations (e.g., overheating), the EUT shall be operated at its maximum power control level with the transmit duration as long as possible and the duty cycle as high as possible.

2. Measurement using a Spectrum Analyzer or EMI Receiver (SA)

Measurement of maximum conducted output power using a spectrum analyzer requires integrating the spectrum across a frequency span that encompasses, at a minimum, either the EBW or the 99-percent occupied bandwidth of the signal.¹ However, the EBW must be used to determine bandwidth dependent limits on maximum conducted output power in accordance with § 15.407(a).

a) The test method shall be selected as follows: (i) Method SA-1 or SA-1 Alternative (averaging with the EUT transmitting at full power throughout each sweep) shall be applied if either of the following conditions can be satisfied:

- The EUT transmits continuously (or with a duty cycle \geq 98 percent).
- Sweep triggering or gating can be implemented in a way that the device transmits at the maximum power control level throughout the duration of each of the instrument sweeps to be averaged. This condition can generally be achieved by triggering the instrument's sweep if the duration of the sweep (with the analyzer configured as in Method SA-1, below) is equal to or shorter than the duration T of each transmission from the EUT and if those transmissions exhibit full power throughout their durations.

(ii) Method SA-2 or SA-2 Alternative (averaging across on and off times of the EUT transmissions, followed by duty cycle correction) shall be applied if the conditions of (i) cannot be achieved and the

transmissions exhibit a constant duty cycle during the measurement duration. Duty cycle will be considered to be constant if variations are less than ± 2 percent.

(iii) Method SA-3 (RMS detection with max hold) or SA-3 Alternative (reduced VBW with max hold) shall be applied if the conditions of (i) and (ii) cannot be achieved.

b) Method SA-1 (trace averaging with the EUT transmitting at full power throughout each sweep): (i) Set span to encompass the entire emission bandwidth (EBW) (or, alternatively, the entire 99% occupied bandwidth) of the signal.

(ii) Set RBW = 1 MHz.

(iii) Set VBW ≥ 3 MHz.

(iv) Number of points in sweep ≥ 2 Span / RBW. (This ensures that bin-to-bin spacing is \leq RBW/2, so that narrowband signals are not lost between frequency bins.)

(v) Sweep time = auto.

(vi) Detector = RMS (i.e., power averaging), if available. Otherwise, use sample detector mode.

(vii) If transmit duty cycle < 98 percent, use a video trigger with the trigger level set to enable triggering only on full power pulses. Transmitter must operate at maximum power control level for the entire duration of every sweep. If the EUT transmits continuously (i.e., with no off intervals) or at duty cycle ≥ 98 percent, and if each transmission is entirely at the maximum power control level, then the trigger shall be set to "free run".

(viii) Trace average at least 100 traces in power averaging (i.e., RMS) mode.

(ix) Compute power by integrating the spectrum across the EBW (or, alternatively, the entire 99% occupied bandwidth) of the signal using the instrument's band power measurement function with band limits set equal to the EBW (or occupied bandwidth) band edges. If the instrument does not have a band power function, sum the spectrum

10.4 EUT operating Conditions

The EUT was configured for testing in a typical fashion (as a customer would normally use it). The EUT has been programmed to continuously transmit during test. This operating condition was tested and used to collect the included data.



10.5 Test Result

Temperature:	26 °C	Relative Humidity:	54%
Pressure:	101KPa	Test Voltage:	DC 11.1V
Test Mode:	TX (5.8G) Mode Frequency U-NII-3 5745-5825MHz		

Condition	Mode	Frequency (MHz)	Conducted Power (dBm)		Total(dBm)	Limit (dBm)	Verdict
			Ant A	Ant B			
NVNT	a	5745	16.87	18.23	/	30	Pass
NVNT	a	5785	16.62	16.44	/	30	Pass
NVNT	a	5825	16.11	15.12	/	30	Pass
NVNT	n20	5745	16.01	16.91	19.49	30	Pass
NVNT	n20	5785	15.35	14.90	18.14	30	Pass
NVNT	n20	5825	15.03	13.88	17.50	30	Pass
NVNT	n40	5755	15.18	16.26	18.76	30	Pass
NVNT	n40	5795	14.69	14.27	17.50	30	Pass

BCTC
 3C
 PPR
 检测

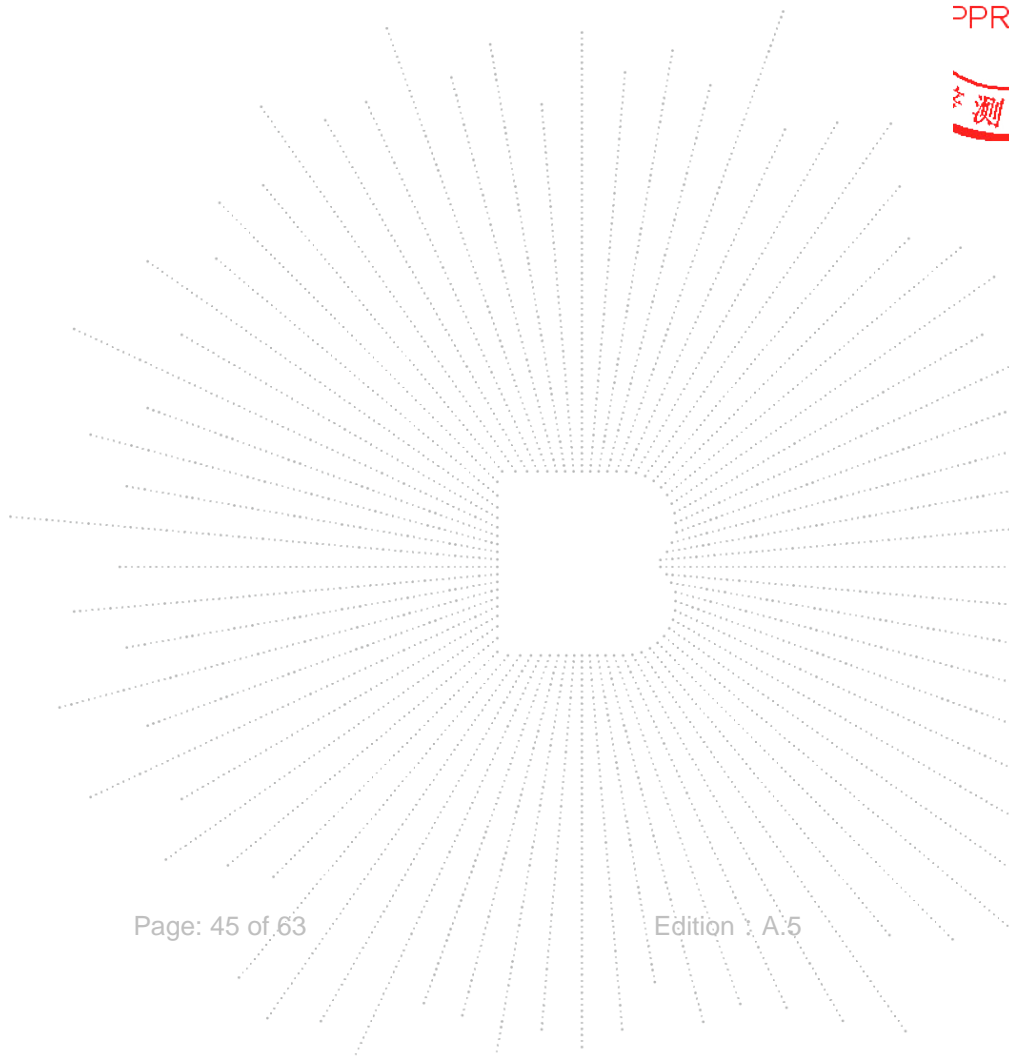

11. Out Of Band Emissions

11.1 Block Diagram Of Test Setup



11.2 Limit

According to FCC §15.407(b)

Undesirable emission limits. Except as shown in paragraph (b)(7) of this section, the maximum emissions outside of the frequency bands of operation shall be attenuated in accordance with the following limits:

(1) For transmitters operating in the 5.15-5.25 GHz band: All emissions outside of the 5.15-5.35 GHz band shall not exceed an e.i.r.p. of -27 dBm/MHz.

(2) All emissions shall be limited to a level of -27 dBm/MHz at 75 MHz or more above or below the band edge increasing linearly to 10 dBm/MHz at 25 MHz above or below the band edge, and from 25 MHz above or below the band edge increasing linearly to a level of 15.6 dBm/MHz at 5 MHz above or below the band edge, and from 5 MHz above or below the band edge increasing linearly to a level of 27 dBm/MHz at the band edge.

11.3 Test procedure

1. Check the calibration of the measuring instrument using either an internal calibrator or a known signal from an external generator.
2. Position the EUT without connection to measurement instrument. Turn on the EUT and connect its antenna terminal to measurement instrument via a low loss cable. Then set it to any one measured frequency within its operating range, and make sure the instrument is operated in its linear range.
3. Set RBW of spectrum analyzer to 1 MHz with a convenient frequency span.
4. Measure the highest amplitude appearing on spectral display and set it as a reference level. Plot the graph with marking the highest point and edge frequency.
5. Repeat above procedures until all measured frequencies were complete.

11.4 EUT operating Conditions

The EUT was configured for testing in a typical fashion (as a customer would normally use it). The EUT has been programmed to continuously transmit during test. This operating condition was tested and used to collect the included data

11.5 Test Result

Note: A(B) Represent the value of antenna A and B, The worst data is Antenna A, only shown Antenna A Plot.



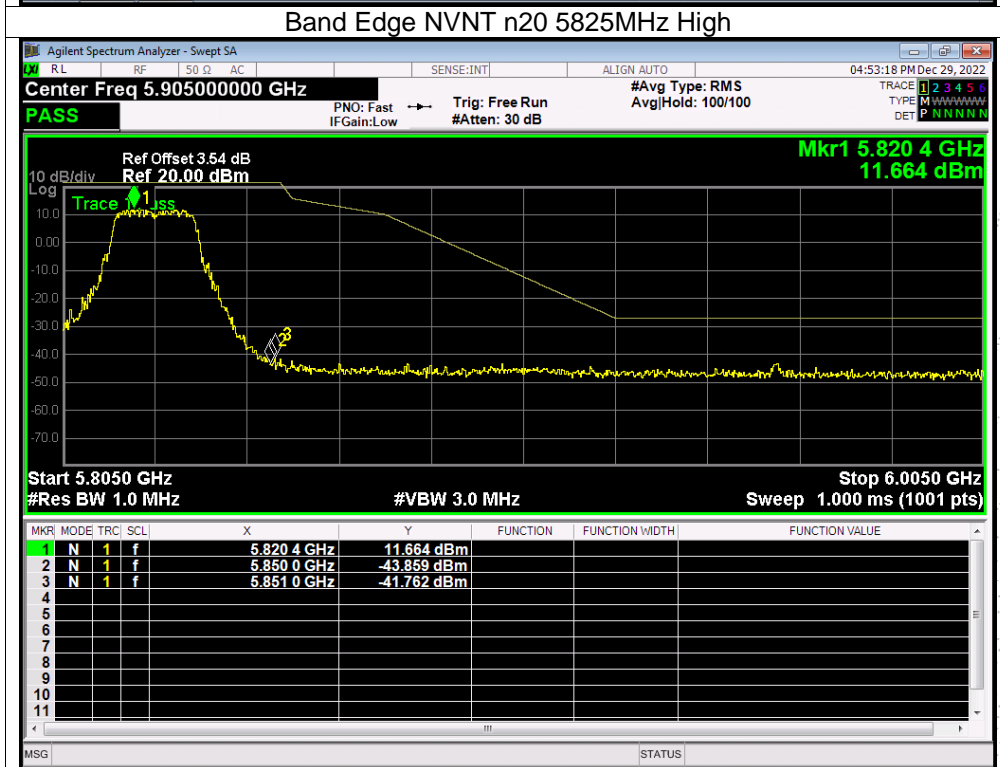
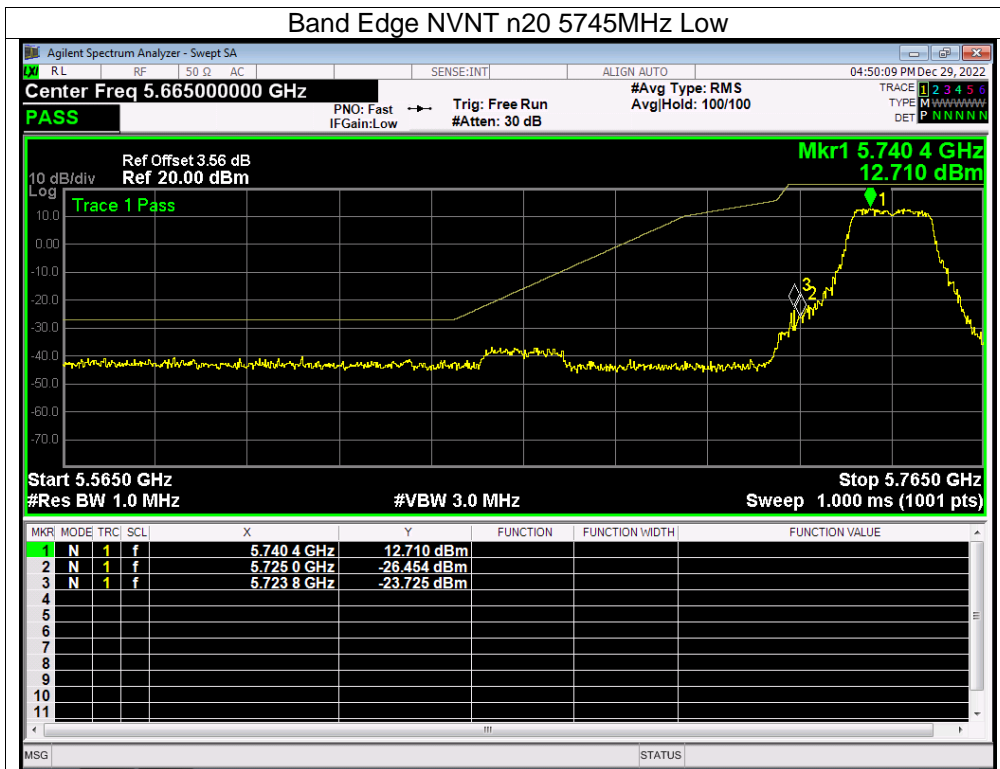

CO., LTD

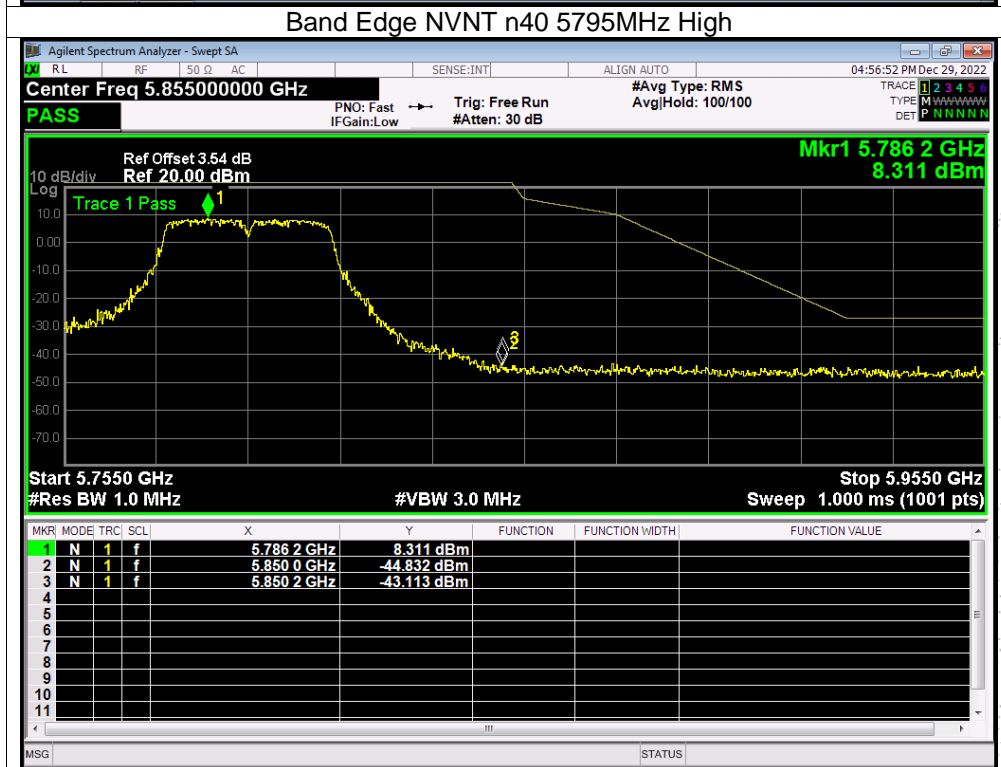
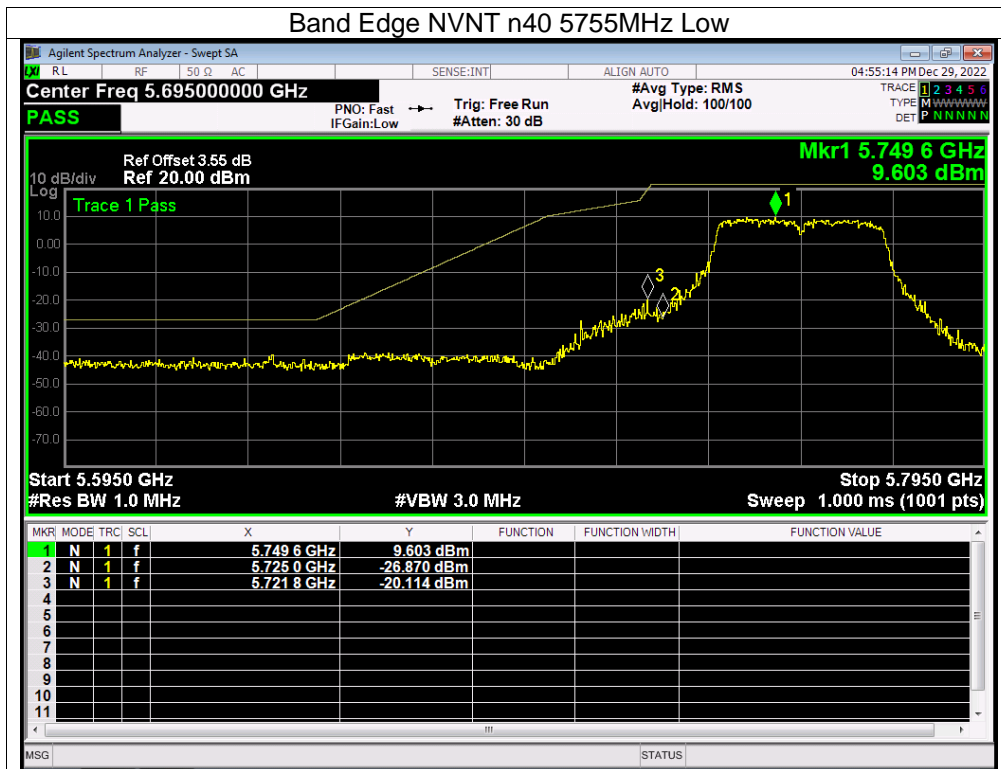

CHENZHEN

12. Spurious RF Conducted Emissions

12.1 Block Diagram Of Test Setup



12.2 Limit

Undesirable emission limits. Except as shown in paragraph (b)(7) of this section, the maximum emissions outside of the frequency bands of operation shall be attenuated in accordance with the following limits:

(1) For transmitters operating in the 5.15-5.25 GHz band: All emissions outside of the 5.15-5.35 GHz band shall not exceed an e.i.r.p. of -27 dBm/MHz.

(2) For transmitters operating in the 5.725-5.85 GHz band(i) All emissions shall be limited to a level of -27 dBm/MHz at 75 MHz or more above or below the band edge increasing linearly to 10 dBm/MHz at 25 MHz above or below the band edge, and from 25 MHz above or below the band edge increasing linearly to a level of 15.6 dBm/MHz at 5 MHz above or below the band edge, and from 5 MHz above or below the band edge increasing linearly to a level of 27 dBm/MHz at the band edge.

12.3 Test procedure

1. Check the calibration of the measuring instrument using either an internal calibrator or a known signal from an external generator.
2. Position the EUT without connection to measurement instrument. Turn on the EUT and connect its antenna terminal to measurement instrument via a low loss cable. Then set it to any one measured frequency within its operating range, and make sure the instrument is operated in its linear range.
3. Set RBW of spectrum analyzer to 1 MHz with a convenient frequency span.
4. Measure the highest amplitude appearing on spectral display and set it as a reference level. Plot the graph with marking the highest point and edge frequency.
5. Repeat above procedures until all measured frequencies were complete.

12.4 Test Result

Remark: The measurement frequency range is from 9KHz to the 10th harmonic of the fundamental frequency. The lowest, middle and highest channels are tested to verify the spurious emissions and bandege measurement data.

About: 26.5GHz-40GHz, The amplitude of spurious emissions which are attenuated by more than 20dB below the permissible value has no need to be reported.

Note: A(B) Represent the value of antenna A and B, The worst data is Antenna B, only shown Antenna B Plot.

Note: A(B) Represent the value of antenna A and B, The worst data is Antenna A, only shown Antenna A Plot.



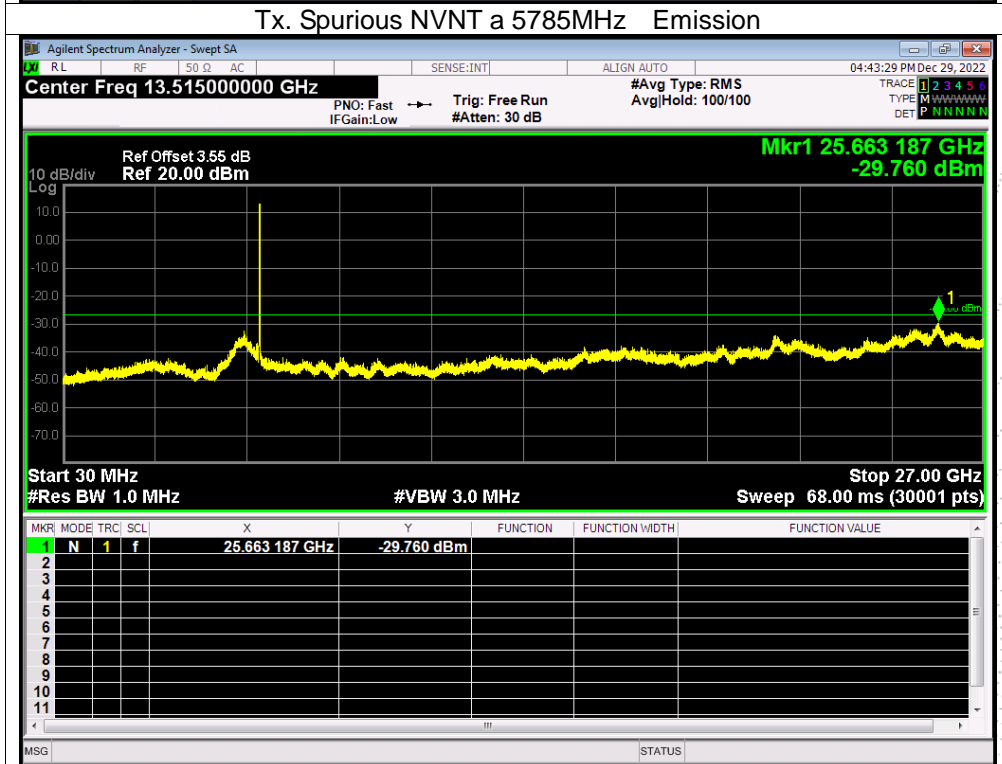
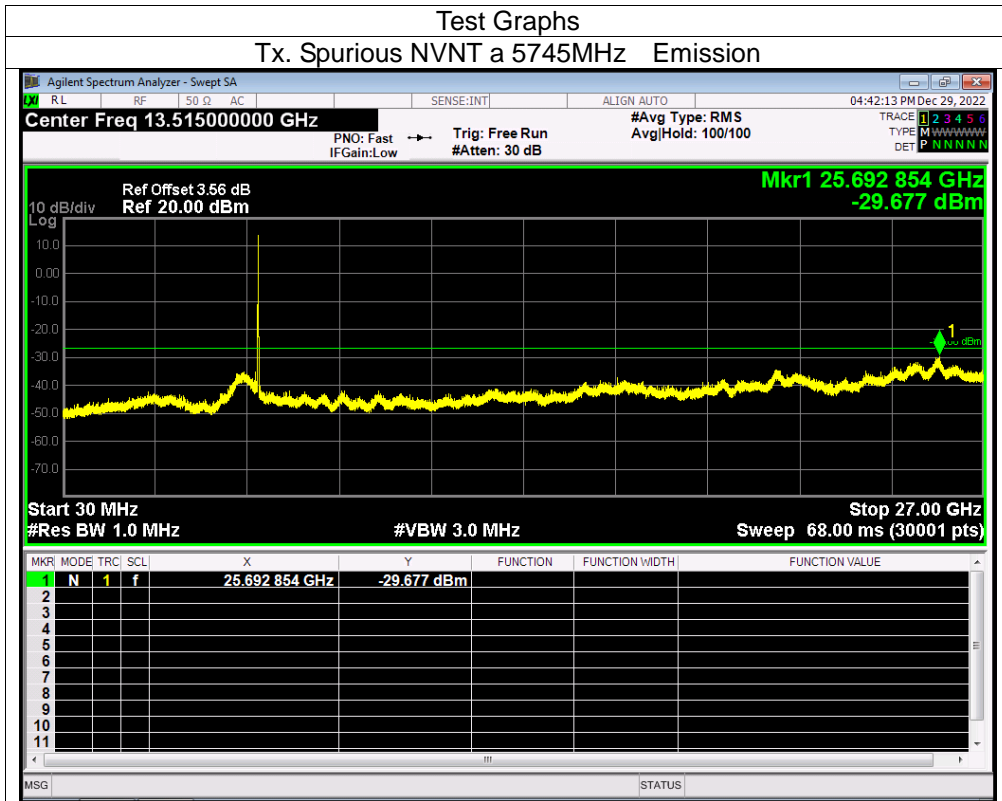

BCTC
 BCTC
 PPR
 本測

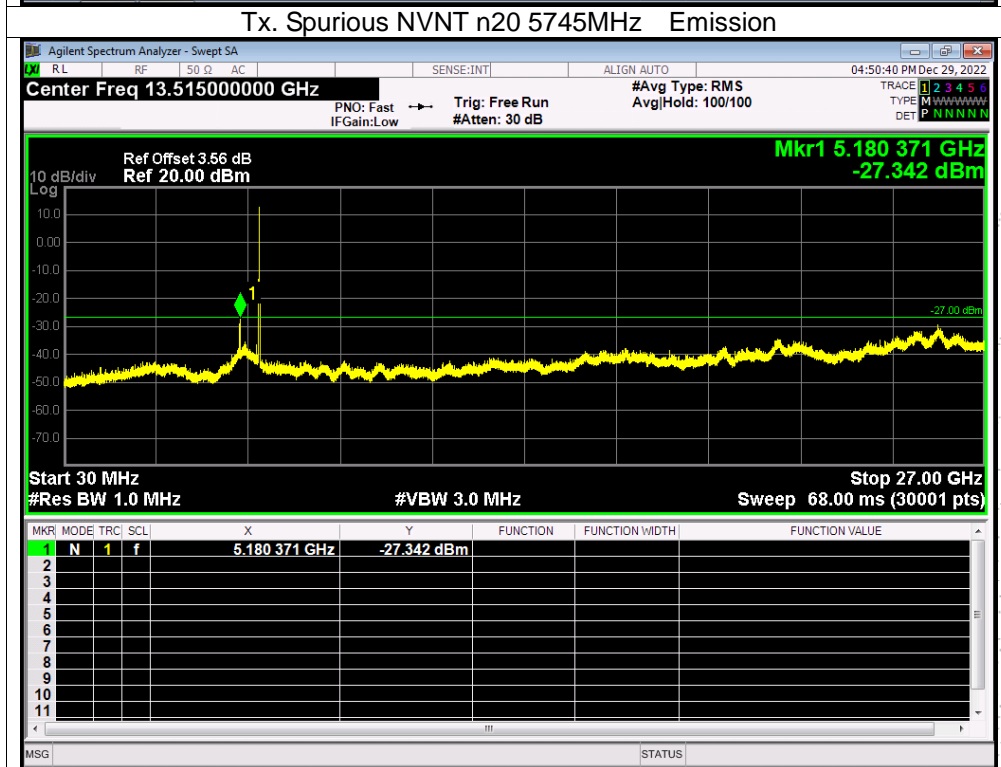
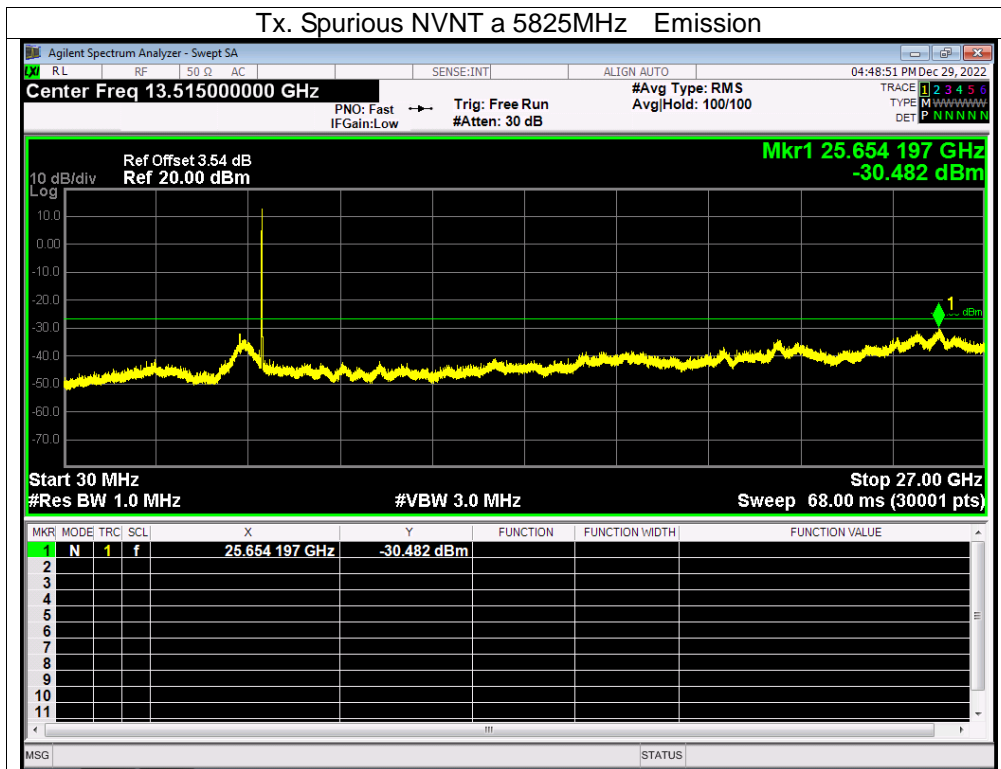

検査
 OVER
 TO
 TEST

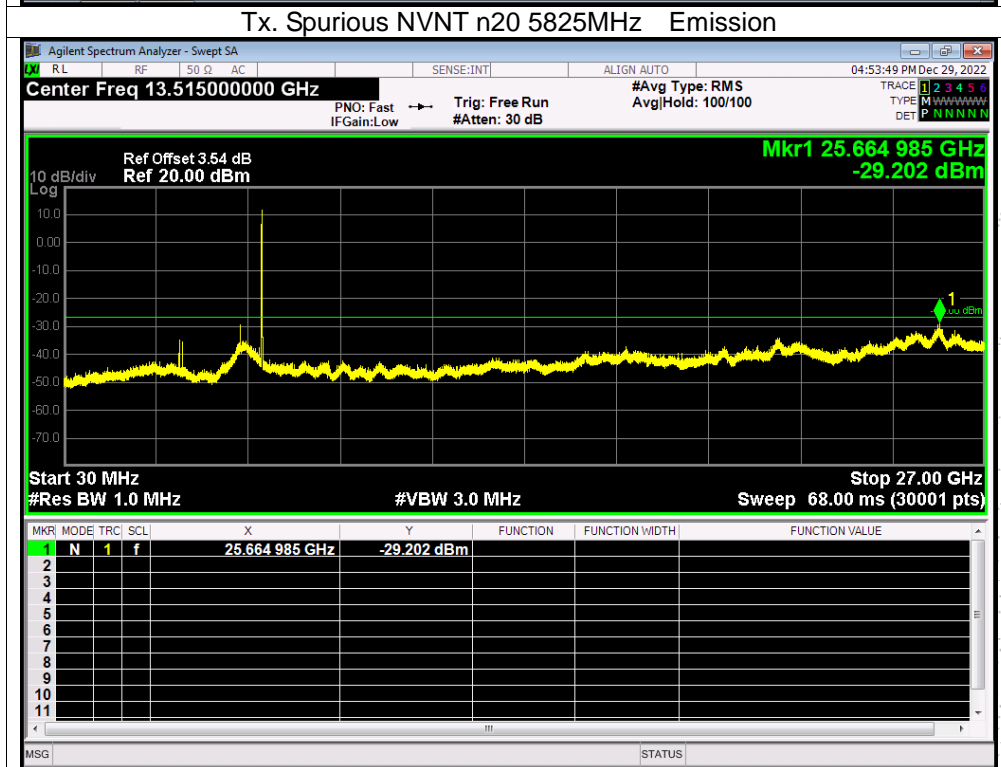
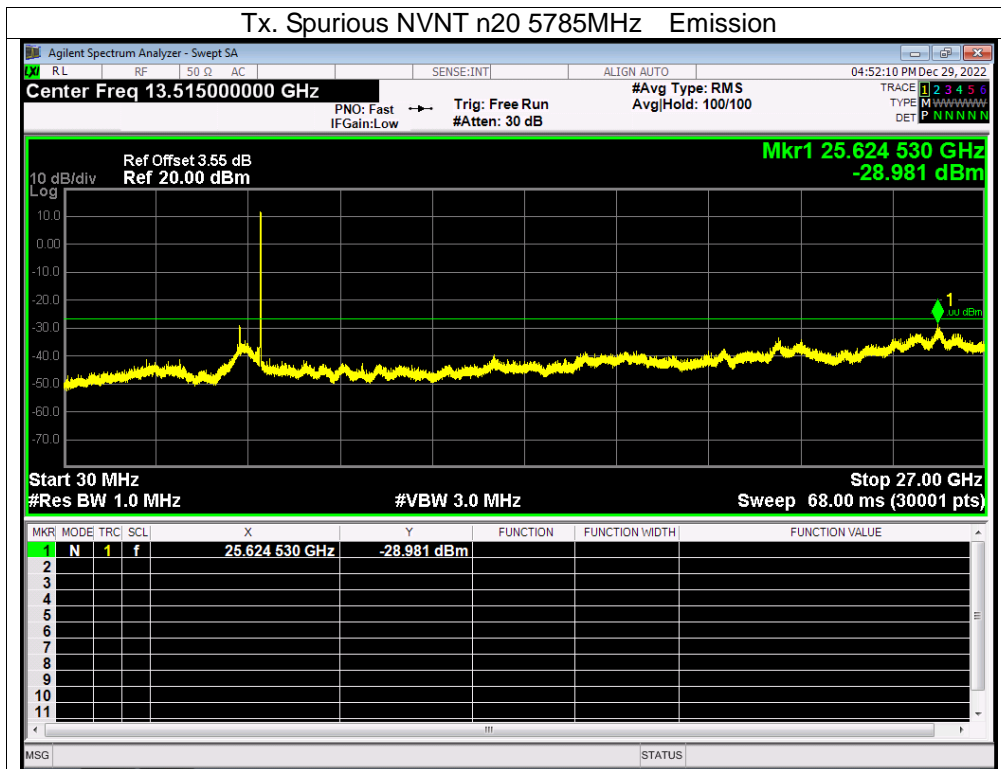

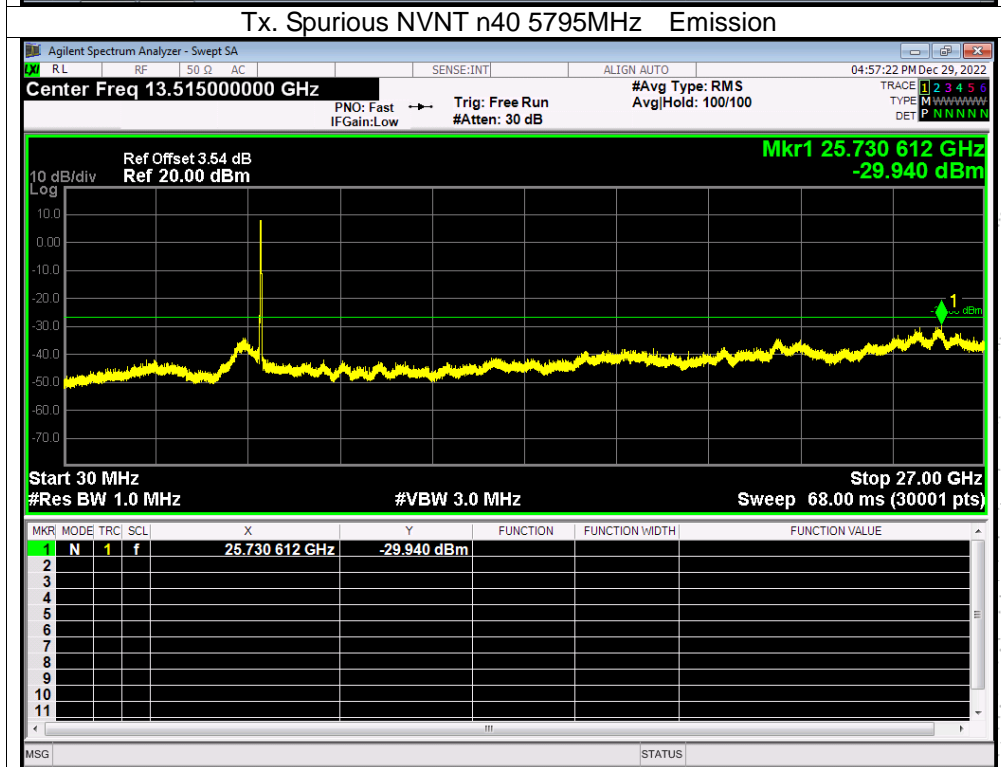
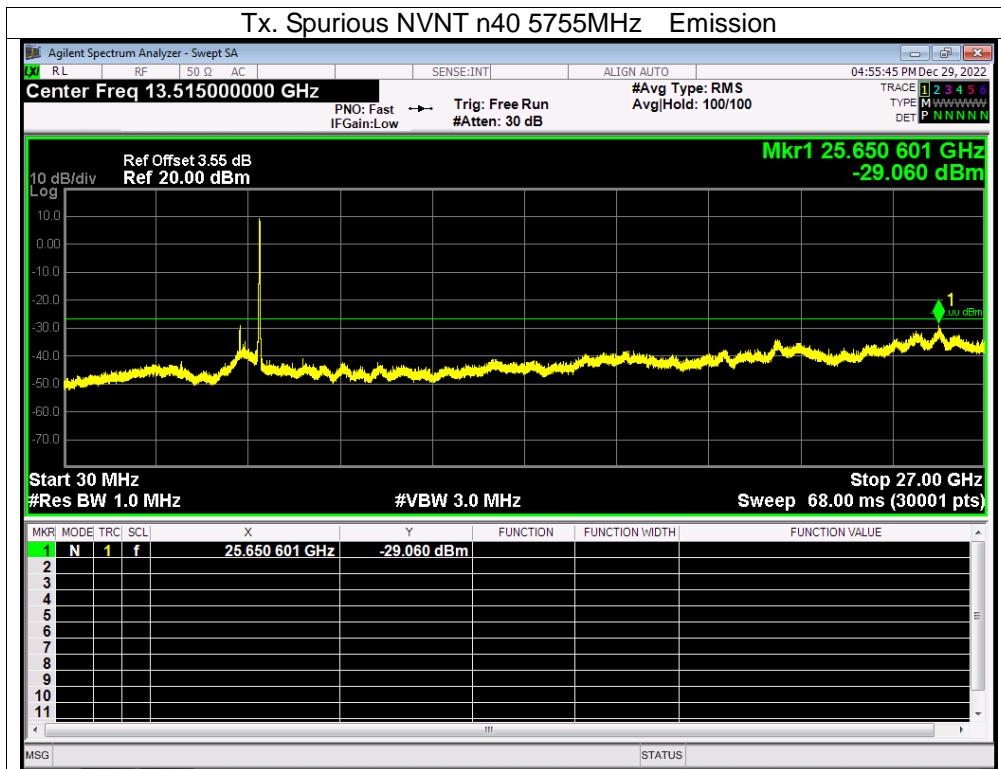

CO., LTD

13. Frequency Stability Measurement

13.1 Block Diagram Of Test Setup



13.2 Limit

Manufactures of U-NII devices are responsible for ensuring frequency stability such that an emission is maintained within the band of operation under all conditions of normal operation as specified in the user's manual.

The transmitter center frequency tolerance shall be ± 20 ppm maximum for the 5 GHz band (IEEE 802.11n specification).

13.3 Test procedure

1. The transmitter output (antenna port) was connected to the spectrum analyzer.
2. EUT have transmitted absence of modulation signal and fixed channelize.
3. Set the spectrum analyzer span to view the entire absence of modulation emissions bandwidth.
4. Set RBW = 10 kHz, VBW = 10 kHz with peak detector and maxhold settings.
5. f_c is declaring of channel frequency. Then the frequency error formula is $(f_c - f) / f_c \times 10^6$ ppm and he limit is less than ± 20 ppm (IEEE 802.11n specification).
6. The test extreme voltage is to change the primary supply voltage from 85 to 115 percent of the nominal value
7. Extreme temperature is $-20^\circ\text{C} \sim 70^\circ\text{C}$.

13.4 Test Result

Temperature:	26 °C	Relative Humidity:	54%
Pressure:	101KPa	Test Voltage:	DC 11.1V
Test Mode:	TX (5.8G) Mode Frequency U-NII-3 (5745-5825MHz)		

Voltage vs. Frequency Stabilit

TEST CONDITIONS				Reference Frequency: 5745MHz			
				f	fc	Max. Deviation (MHz)	Max. Deviation (ppm)
T nom (°C)	20	V nom (V)	120.00	5745.00626	5745	0.00626	1.0895
		V max (V)	138.00	5745.00155	5745	0.00155	0.2693
		V min (V)	102.00	5745.00971	5745	0.00971	1.6902
Limits				5725-5850 MHz			
Result				Complies			

Temperature vs. Frequency Stability

TEST CONDITIONS				Reference Frequency: 5745MHz			
				f	fc	Max. Deviation (MHz)	Max. Deviation (ppm)
V nom (V)	120	T (°C)	-20	5745.00961	5745	0.00961	1.6723
		T (°C)	-10	5745.00582	5745	0.00582	1.0123
		T (°C)	0	5745.00332	5745	0.00332	0.5772
		T (°C)	10	5745.00376	5745	0.00376	0.6553
		T (°C)	20	5745.00187	5745	0.00187	0.3261
		T (°C)	30	5745.00460	5745	0.00460	0.8010
		T (°C)	40	5745.00887	5745	0.00887	1.5443
		T (°C)	50	5745.00078	5745	0.00078	0.1360
		T (°C)	60	5745.00447	5745	0.00447	0.7780
		T (°C)	70	5745.00759	5745	0.00759	1.3212
Limits				5725-5850 MHz			
Result				Complies			

Voltage vs. Frequency Stability

TEST CONDITIONS				Reference Frequency: 5785MHz			
				f	fc	Max. Deviation (MHz)	Max. Deviation (ppm)
T nom (°C)	20	V nom (V)	120.00	5785.00484	5785	0.00484	0.8359
		V max (V)	138.00	5785.00112	5785	0.00112	0.1943
		V min (V)	102.00	5785.00520	5785	0.00520	0.8985
Limits				5725-5850 MHz			
Result				Complies			

Temperature vs. Frequency Stability

TEST CONDITIONS				Reference Frequency: 5785MHz			
				f	fc	Max. Deviation (MHz)	Max. Deviation (ppm)
V nom (V)	120	T (°C)	-20	5785.00636	5785	0.00636	1.0996
		T (°C)	-10	5785.00884	5785	0.00884	1.5288
		T (°C)	0	5785.00953	5785	0.00953	1.6481
		T (°C)	10	5785.00986	5785	0.00986	1.7036
		T (°C)	20	5785.01323	5785	0.01323	2.2876
		T (°C)	30	5785.00285	5785	0.00285	0.4934
		T (°C)	40	5785.00654	5785	0.00654	1.1304
		T (°C)	50	5785.00435	5785	0.00435	0.7517
		T (°C)	60	5785.01125	5785	0.01125	1.9443
		T (°C)	70	5785.00161	5785	0.00161	0.2775
Limits				5725-5850 MHz			
Result				Complies			

Voltage vs. Frequency Stability

TEST CONDITIONS				Reference Frequency: 5825MHz			
				f	fc	Max. Deviation (MHz)	Max. Deviation (ppm)
T nom (°C)	20	V nom (V)	120.00	5825.00619	5825	0.00619	1.0624
		V max (V)	138.00	5825.00179	5825	0.00179	0.3081
		V min (V)	102.00	5825.01274	5825	0.01274	2.1879
Limits				5725-5850 MHz			
Result				Complies			

Temperature vs. Frequency Stability

TEST CONDITIONS				Reference Frequency: 5825MHz			
				f	fc	Max. Deviation (MHz)	Max. Deviation (ppm)
V nom (V)	120	T (°C)	-20	5825.00021	5825	0.00021	0.0357
		T (°C)	-10	5825.01043	5825	0.01043	1.7898
		T (°C)	0	5825.00876	5825	0.00876	1.5035
		T (°C)	10	5825.00657	5825	0.00657	1.1279
		T (°C)	20	5825.00487	5825	0.00487	0.8355
		T (°C)	30	5825.01313	5825	0.01313	2.2544
		T (°C)	40	5825.00931	5825	0.00931	1.5986
		T (°C)	50	5825.00611	5825	0.00611	1.0487
		T (°C)	60	5825.00042	5825	0.00042	0.0714
		T (°C)	70	5825.01128	5825	0.01128	1.9370
Limits				5725-5850 MHz			
Result				Complies			

14. Antenna Requirement

14.1 Limit

15.203 requirement: For intentional device, according to 15.203: an intentional radiator shall be designed to ensure that no antenna other than that furnished by the responsible party shall be used with the device.

14.2 Test Antenna

The EUT antenna is External antenna. It comply with the standard requirement.

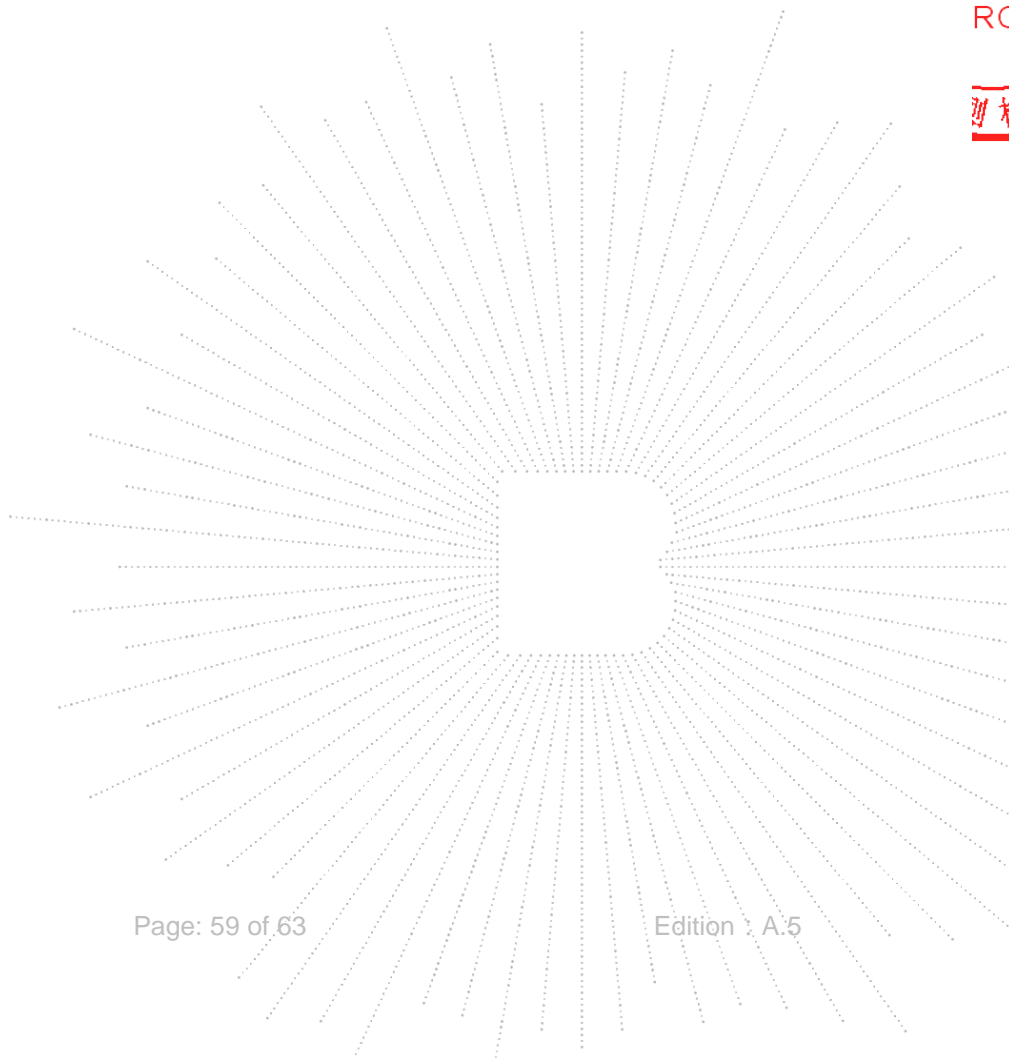

15. EUT Photographs

EUT Photo



Appendix-Photographs Of EUT Constructional Details

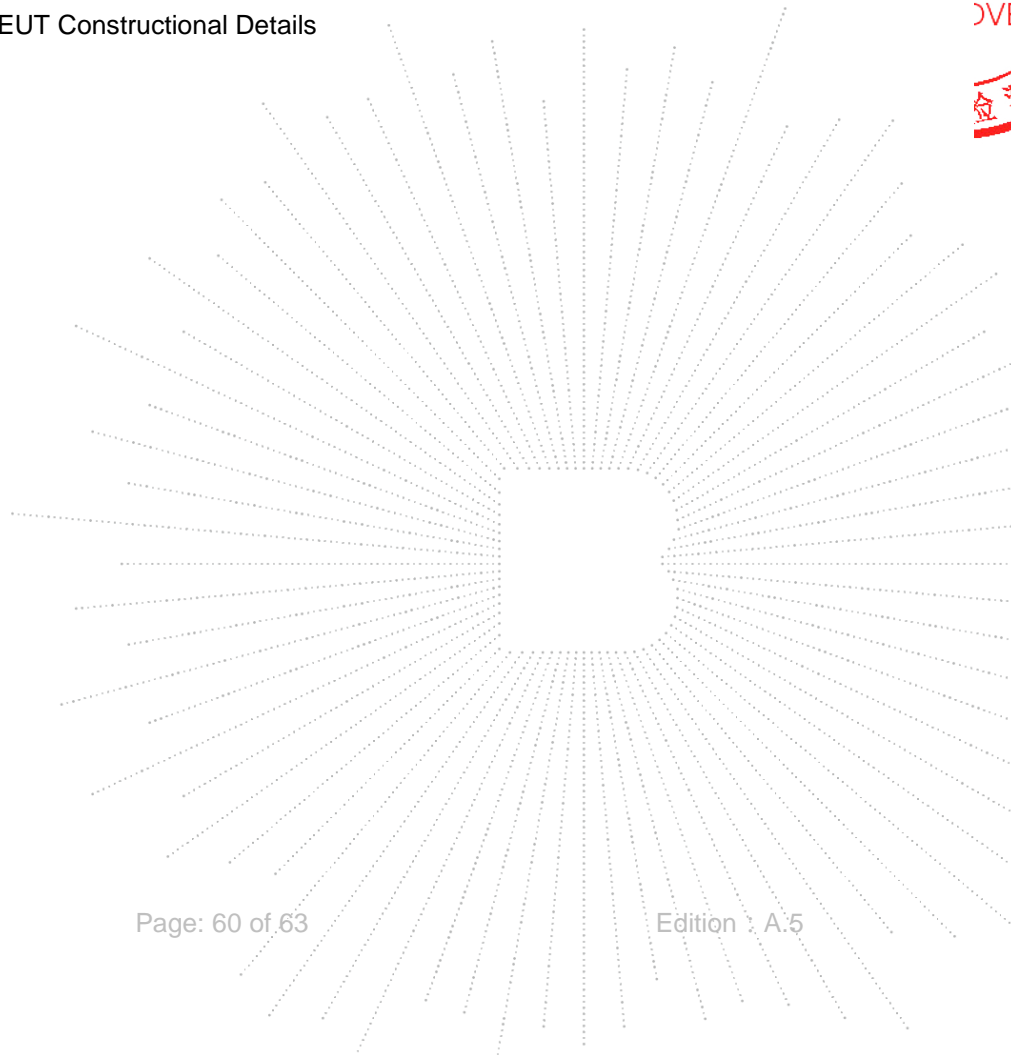

16. EUT Test Setup Photographs

Conducted emissions



Radiated Measurement Photos

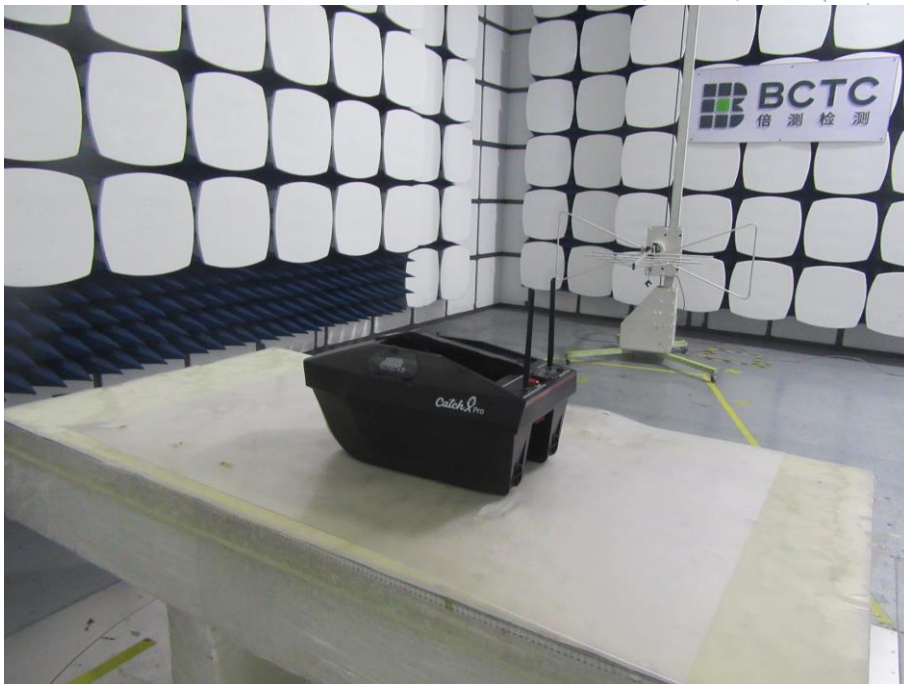

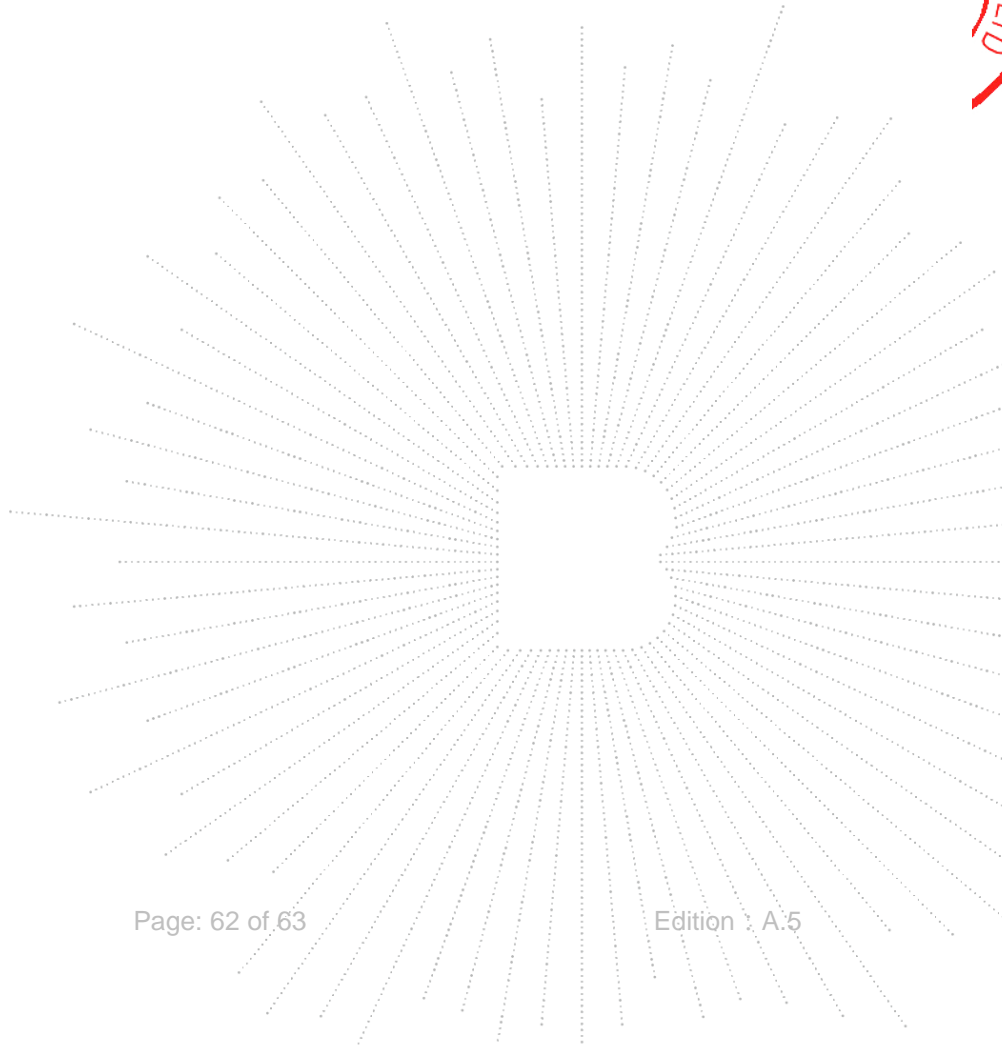
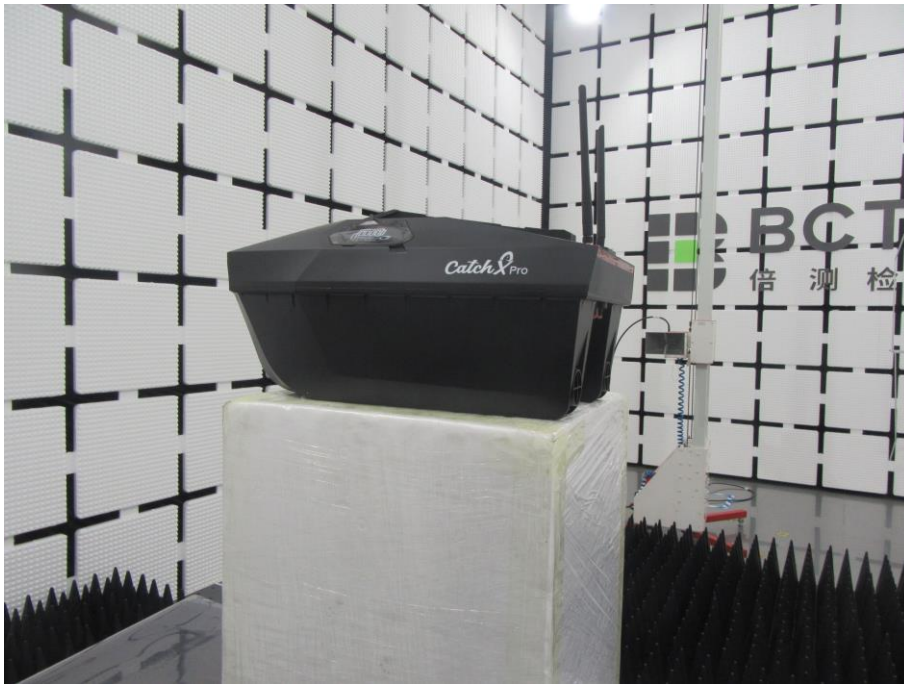

STATEMENT

1. The equipment lists are traceable to the national reference standards.
2. The test report can not be partially copied unless prior written approval is issued from our lab.
3. The test report is invalid without the "special seal for inspection and testing".
4. The test report is invalid without the signature of the approver.
5. The test process and test result is only related to the Unit Under Test.
6. Sample information is provided by the client and the laboratory is not responsible for its authenticity.
7. The test report without CMA mark is only used for scientific research, teaching, enterprise product development and internal quality control purposes.
8. The quality system of our laboratory is in accordance with ISO/IEC17025.
9. If there is any objection to this test report, the client should inform issuing laboratory within 15 days from the date of receiving test report.

Address:

1-2/F., Building B, Pengzhou Industrial Park, No.158, Fuyuan 1st Road, Zhancheng, Fuhai Subdistrict, Bao'an District, Shenzhen, Guangdong, China

TEL : 400-788-9558

P.C.: 518103

FAX : 0755-33229357

Website : <http://www.chnbctc.com>E-Mail : bctc@bctc-lab.com.cn******* END *******

2017