

Test Report

Report No.: MTi240430007-01E1

Date of issue: 2024-05-29

Applicant: Zhuhai Quin Technology Co., Ltd.

Product: Multifunctional Portable Label Maker

Model(s): M220, M220 Pro, M333, M333 Pro, M324, M324 Pro, M325, M325 Pro, M200, M200 Pro, M330, M330 Pro, M208, M208 Pro, M331, M331 Pro, M209, M209 Pro, M332, M332 Pro, M221, M221 Pro, M334, M334 Pro, M321, M321 Pro, M335, M335 Pro, M322, M322 Pro, M336, M336 Pro, M326, M326 Pro, M327, M327 Pro, M250, M323, M323 Pro, M337, M337 Pro, M260

FCC ID: 2ASRB-3INCH

Shenzhen Microtest Co., Ltd.

<http://www.mtitest.cn>

The test report is only used for customer scientific research, teaching, internal quality control and other purposes, and is for internal reference only.



Instructions

1. This test report shall not be partially reproduced without the written consent of the laboratory.
2. The test results in this test report are only responsible for the samples submitted
3. This test report is invalid without the seal and signature of the laboratory.
4. This test report is invalid if transferred, altered, or tampered with in any form without authorization.
5. Any objection to this test report shall be submitted to the laboratory within 15 days from the date of receipt of the report.

Table of contents

1	General Description	5
1.1	Description of the EUT	5
1.2	Description of test modes	5
1.3	Environmental Conditions	7
1.4	Description of support units	7
1.5	Measurement uncertainty	7
2	Summary of Test Result	8
3	Test Facilities and accreditations	9
3.1	Test laboratory	9
4	List of test equipment.....	10
5	Evaluation Results (Evaluation).....	11
5.1	Antenna requirement	11
6	Radio Spectrum Matter Test Results (RF)	12
6.1	Conducted Emission at AC power line	12
6.2	Occupied Bandwidth	18
6.3	Maximum Conducted Output Power.....	20
6.4	Channel Separation	22
6.5	Number of Hopping Frequencies.....	23
6.6	Dwell Time	24
6.7	RF conducted spurious emissions and band edge measurement	26
6.8	Band edge emissions (Radiated)	27
6.9	Radiated emissions (below 1GHz)	30
6.10	Radiated emissions (above 1GHz).....	37
	Photographs of the test setup	41
	Photographs of the EUT.....	42
	Appendix A: 20dB Emission Bandwidth	43
	Appendix B: Maximum conducted output power.....	46
	Appendix C: Carrier frequency separation	49
	Appendix D: Time of occupancy	51
	Appendix E: Number of hopping channels.....	56
	Appendix F: Band edge measurements.....	58
	Appendix G: Conducted Spurious Emission.....	61

Test Result Certification	
Applicant:	Zhuhai Quin Technology Co., Ltd.
Address:	ROOM 103-029(CENTRALIZED OFFICE AREA), 1F, BUILDING 1, NO. 18 FUTIAN ROAD, XIANGZHOU DISTRICT, ZHUHAI CITY, CHINA
Manufacturer:	Zhuhai Quin Technology Co., Ltd.
Address:	ROOM 103-029(CENTRALIZED OFFICE AREA), 1F, BUILDING 1, NO. 18 FUTIAN ROAD, XIANGZHOU DISTRICT, ZHUHAI CITY, CHINA
Product description	
Product name:	Multifunctional Portable Label Maker
Trade mark:	N/A
Model name:	M220
Series Model(s):	M220 Pro, M333, M333 Pro, M324, M324 Pro, M325, M325 Pro, M200, M200 Pro, M330, M330 Pro, M208, M208 Pro, M331, M331 Pro, M209, M209 Pro, M332, M332 Pro, M221, M221 Pro, M334, M334 Pro, M321, M321 Pro, M335, M335 Pro, M322, M322 Pro, M336, M336 Pro, M326, M326 Pro, M327, M327 Pro, M250, M323, M323 Pro, M337, M337 Pro, M260
Standards:	47 CFR Part 15.247
Test Method:	ANSI C63.10-2020 KDB 558074 D01 15.247 Meas Guidance v05r02
Date of Test	
Date of test:	2024-05-23 to 2024-05-27
Test result:	Pass

Test Engineer	:	<i>Letter Lan.</i>
		(Letter Lan)
Reviewed By	:	<i>David Lee</i>
		(David Lee)
Approved By	:	<i>Leon Chen</i>
		(Leon Chen)

1 General Description

1.1 Description of the EUT

Product name:	Multifunctional Portable Label Maker
Model name:	M220
Series Model(s):	M220 Pro, M333, M333 Pro, M324, M324 Pro, M325, M325 Pro, M200, M200 Pro, M330, M330 Pro, M208, M208 Pro, M331, M331 Pro, M209, M209 Pro, M332, M332 Pro, M221, M221 Pro, M334, M334 Pro, M321, M321 Pro, M335, M335 Pro, M322, M322 Pro, M336, M336 Pro, M326, M326 Pro, M327, M327 Pro, M250, M323, M323 Pro, M337, M337 Pro, M260
Model difference:	All the models are the same circuit and module, except the model name appearance and color.
Electrical rating:	Input: 5VDC 2A Battery: 7.4VDC 2200mAh
Accessories:	Cable: USB-A to Type-c cable 0.8m
Hardware version:	Q198_A
Software version:	2.0.5
Test sample(s) number:	MTi240430007-01S1001(RF Conducted test) (Model: M220) MTi240430007-01S2001(Radiated test) (Model: M220) MTi240430007-02S1001(AC Conducted test+ Radiated test (30- 1000MHz) (Model: M200) MTi240430007-02S2001(AC Conducted test+ Radiated test (30- 1000MHz) (Model: M221) MTi240430007-02S3001(AC Conducted test+ Radiated test (30- 1000MHz) (Model: M260) MTi240430007-02S4001(AC Conducted test+ Radiated test (30- 1000MHz) (Model: M250) MTi240430007-02S5001(AC Conducted test) (Model: M220)
RF specification	
Bluetooth version:	V5.3
Operating frequency range:	2402-2480MHz
Channel number:	79
Modulation type:	GFSK, $\pi/4$ -DQPSK
Antenna(s) type:	PCB
Antenna(s) gain:	-0.58dBi

1.2 Description of test modes

No.	Emission test modes
Mode1	TX-GFSK
Mode2	TX- $\pi/4$ -DQPSK

1.2.1 Operation channel list

Channel	Frequency (MHz)	Channel	Frequency (MHz)	Channel	Frequency (MHz)	Channel	Frequency (MHz)
0	2402	20	2422	40	2442	60	2462

1	2403	21	2423	41	2443	61	2463
2	2404	22	2424	42	2444	62	2464
3	2405	23	2425	43	2445	63	2465
4	2406	24	2426	44	2446	64	2466
5	2407	25	2427	45	2447	65	2467
6	2408	26	2428	46	2448	66	2468
7	2409	27	2429	47	2449	67	2469
8	2410	28	2430	48	2450	68	2470
9	2411	29	2431	49	2451	69	2471
10	2412	30	2432	50	2452	70	2472
11	2413	31	2433	51	2453	71	2473
12	2414	32	2434	52	2454	72	2474
13	2415	33	2435	53	2455	73	2475
14	2416	34	2436	54	2456	74	2476
15	2417	35	2437	55	2457	75	2477
16	2418	36	2438	56	2458	76	2478
17	2419	37	2439	57	2459	77	2479
18	2420	38	2440	58	2460	78	2480
19	2421	39	2441	59	2461	-	-

Test Channel List

Operation Band: 2400-2483.5 MHz

Bandwidth (MHz)	Lowest Channel (LCH) (MHz)	Middle Channel (MCH) (MHz)	Highest Channel (HCH) (MHz)
1	2402	2441	2480

Note: The test software provided by manufacturer is used to control EUT for working in engineering mode, that enables selectable channel, and capable of continuous transmitting mode.

Test Software: FCC Assist 1.0.2.2

For power setting, refer to below table.

Mode	2402MHz	2441MHz	2480MHz
GFSK	10	10	10
$\pi/4$ -DQPSK	10	10	10

1.3 Environmental Conditions

During the measurement the environmental conditions were within the listed ranges:

Temperature:	15°C ~ 35°C
Humidity:	20% RH ~ 75% RH
Atmospheric pressure:	98 kPa ~ 101 kPa

1.4 Description of support units

The EUT has been tested as an independent unit together with other necessary accessories or support units. The following support units or accessories were used to form a representative test configuration during the tests.

Support equipment list			
Description	Model	Serial No.	Manufacturer
MI CHARGE(33W)	MDY-11-EX	SA623116200029J	MI
Support cable list			
Description	Length (m)	From	To
/	/	/	/

1.5 Measurement uncertainty

Measurement	Uncertainty
Conducted emissions (AMN 150kHz~30MHz)	±3.1dB
Occupied channel bandwidth	±3 %
RF output power, conducted	±1 dB
Time	±1 %
Unwanted Emissions, conducted	±1 dB
Radiated spurious emissions (above 1GHz)	±5.3dB
Radiated spurious emissions (9kHz~30MHz)	±4.3dB
Radiated spurious emissions (30MHz~1GHz)	±4.7dB
Temperature	±1 °C
Humidity	± 5 %

This uncertainty represents an expanded uncertainty expressed at approximately the 95% confidence level using a coverage factor of k=2.

2 Summary of Test Result

No.	Item	Standard	Requirement	Result
1	Antenna requirement	47 CFR Part 15.247	47 CFR 15.203	Pass
2	Conducted Emission at AC power line	47 CFR Part 15.247	47 CFR 15.207(a)	Pass
3	Occupied Bandwidth	47 CFR Part 15.247	47 CFR 15.215(c)	Pass
4	Maximum Conducted Output Power	47 CFR Part 15.247	47 CFR 15.247(b)(1)	Pass
5	Channel Separation	47 CFR Part 15.247	47 CFR 15.247(a)(1)	Pass
6	Number of Hopping Frequencies	47 CFR Part 15.247	47 CFR 15.247(a)(1)(iii)	Pass
7	Dwell Time	47 CFR Part 15.247	47 CFR 15.247(a)(1)(iii)	Pass
8	RF conducted spurious emissions and band edge measurement	47 CFR Part 15.247	47 CFR 15.247(d), 15.209, 15.205	Pass
9	Band edge emissions (Radiated)	47 CFR Part 15.247	47 CFR 15.247(d), 15.209, 15.205	Pass
10	Radiated emissions (below 1GHz)	47 CFR Part 15.247	47 CFR 15.247(d), 15.209, 15.205	Pass
11	Radiated emissions (above 1GHz)	47 CFR Part 15.247	47 CFR 15.247(d), 15.209, 15.205	Pass

3 Test Facilities and accreditations

3.1 Test laboratory

Test laboratory:	Shenzhen Microtest Co., Ltd.
Test site location:	101, No.7, Zone 2, Xinxing Industrial Park, Fuhai Avenue, Xinhe Community, Fuhai Street, Bao'an District, Shenzhen, Guangdong, China
Telephone:	(86-755)88850135
Fax:	(86-755)88850136
CNAS Registration No.:	CNAS L5868
FCC Registration No.:	448573
IC Registration No.:	21760
CABID:	CN0093

4 List of test equipment

No.	Equipment	Manufacturer	Model	Serial No.	Cal. date	Cal. Due
Conducted Emission at AC power line						
1	EMI Test Receiver	Rohde&schwarz	ESCI3	101368	2024-03-20	2025-03-19
2	Artificial mains network	Schwarzbeck	NSLK 8127	183	2024-03-21	2025-03-20
3	Artificial Mains Network	Rohde & Schwarz	ESH2-Z5	100263	2024-03-20	2025-03-19
Occupied Bandwidth Maximum Conducted Output Power Channel Separation Number of Hopping Frequencies Dwell Time Emissions in non-restricted frequency bands						
1	Wideband Radio Communication Tester	Rohde&schwarz	CMW500	149155	2024-03-20	2025-03-19
2	ESG Series Analog Ssignal Generator	Agilent	E4421B	GB40051240	2024-03-21	2025-03-20
3	PXA Signal Analyzer	Agilent	N9030A	MY51350296	2024-03-21	2025-03-20
4	Synthesized Sweeper	Agilent	83752A	3610A01957	2024-03-21	2025-03-20
5	MXA Signal Analyzer	Agilent	N9020A	MY50143483	2024-03-21	2025-03-20
6	RF Control Unit	Tonscend	JS0806-1	19D8060152	2024-03-21	2025-03-20
7	Band Reject Filter Group	Tonscend	JS0806-F	19D8060160	2024-03-21	2025-03-20
8	ESG Vector Signal Generator	Agilent	N5182A	MY50143762	2024-03-20	2025-03-19
9	DC Power Supply	Agilent	E3632A	MY40027695	2024-03-21	2025-03-20
Band edge emissions (Radiated) Emissions in frequency bands (above 1GHz)						
1	EMI Test Receiver	Rohde&schwarz	ESCI7	101166	2024-03-20	2025-03-19
2	Double Ridged Broadband Horn Antenna	schwarabeck	BBHA 9120 D	2278	2023-06-17	2025-06-16
3	Amplifier	Agilent	8449B	3008A01120	2024-03-20	2025-03-19
4	MXA signal analyzer	Agilent	N9020A	MY54440859	2024-03-21	2025-03-20
5	PXA Signal Analyzer	Agilent	N9030A	MY51350296	2024-03-21	2025-03-20
6	Horn antenna	Schwarzbeck	BBHA 9170	00987	2023-06-17	2025-06-16
7	Pre-amplifier	Space-Dtronics	EWLAN1840 G	210405001	2024-03-21	2025-03-20
Emissions in frequency bands (below 1GHz)						
1	EMI Test Receiver	Rohde&schwarz	ESCI7	101166	2024-03-20	2025-03-19
2	TRILOG Broadband Antenna	schwarabeck	VULB 9163	9163-1338	2023-06-11	2025-06-10
3	Active Loop Antenna	Schwarzbeck	FMZB 1519 B	00066	2024-03-23	2025-03-22
4	Amplifier	Hewlett-Packard	8447F	3113A06184	2024-03-20	2025-03-19

5 Evaluation Results (Evaluation)

5.1 Antenna requirement

Test Requirement:	Refer to 47 CFR Part 15.203, an intentional radiator shall be designed to ensure that no antenna other than that furnished by the responsible party shall be used with the device. The use of a permanently attached antenna or of an antenna that uses a unique coupling to the intentional radiator shall be considered sufficient to comply with the provisions of this section.
-------------------	---

5.1.1 Conclusion:

The antenna of the EUT is permanently attached. The EUT complies with the requirement of FCC PART 15.203.
--

6 Radio Spectrum Matter Test Results (RF)

6.1 Conducted Emission at AC power line

Test Requirement:	Refer to 47 CFR 15.207(a), Except as shown in paragraphs (b) and (c) of this section, for an intentional radiator that is designed to be connected to the public utility (AC) power line, the radio frequency voltage that is conducted back onto the AC power line on any frequency or frequencies, within the band 150 kHz to 30 MHz, shall not exceed the limits in the following table, as measured using a 50 μ H/50 ohms line impedance stabilization network (LISN).		
Test Limit:	Frequency of emission (MHz)	Conducted limit (dB μ V)	
		Quasi-peak	Average
	0.15-0.5	66 to 56*	56 to 46*
	0.5-5	56	46
	5-30	60	50
	*Decreases with the logarithm of the frequency.		
Test Method:	ANSI C63.10-2020 section 6.2		
Procedure:	Refer to ANSI C63.10-2020 section 6.2, standard test method for ac power-line conducted emissions from unlicensed wireless devices		

6.1.1 E.U.T. Operation:

Operating Environment:					
Temperature:	15.5 °C	Humidity:	38.4 %	Atmospheric Pressure:	99 kPa
Pre test mode:	Mode1, Mode2				
Final test mode:	All of the listed pre-test mode were tested, only the data of the worst mode (Mode1) is recorded in the report				

6.1.2 Test Setup Diagram:

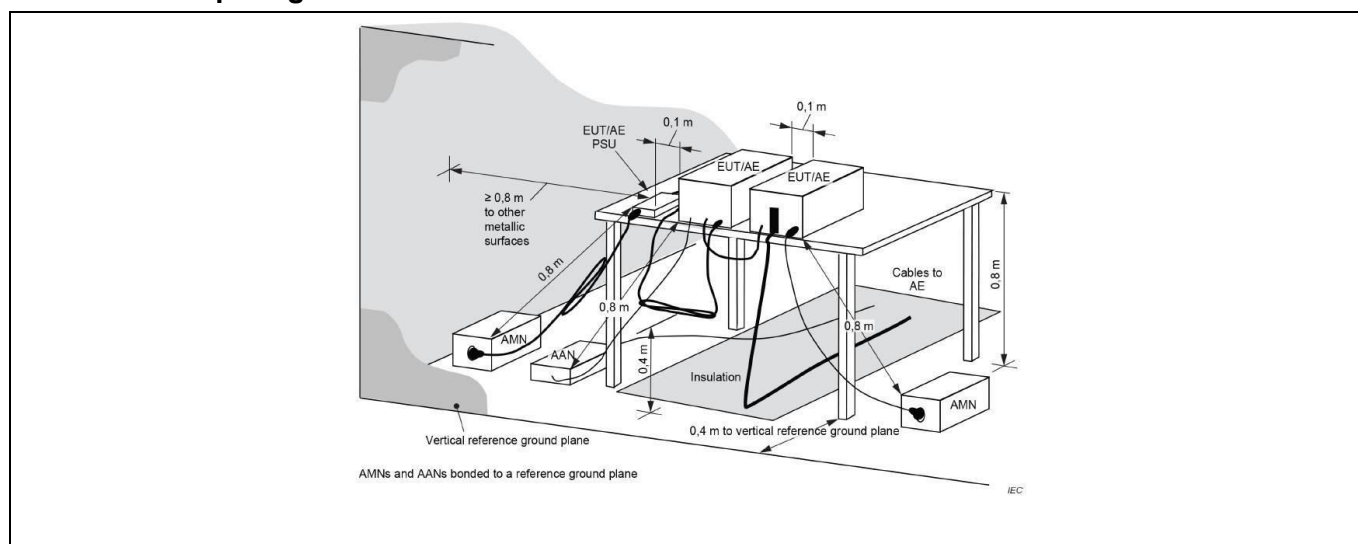

6.1.3 Test Data:

M200

Mode1 / Line: Line / CH: L

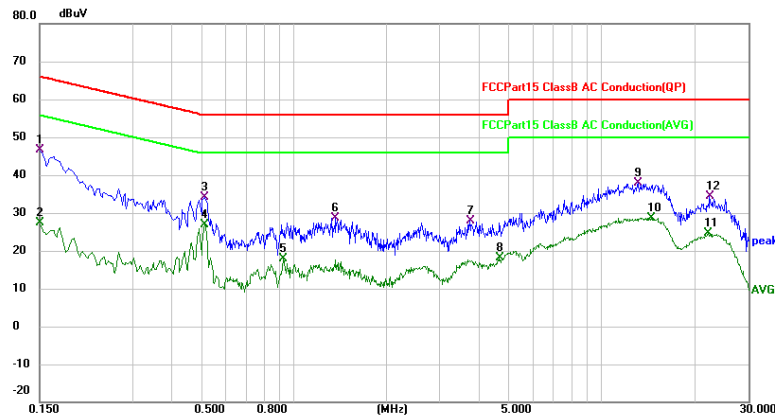

No.	Mk.	Freq.	Reading Level	Correct Factor	Measurement	Limit	Over	Detector	Comment
		MHz	dBuV	dB	dBuV	dBuV	dB		
1		0.1500	36.28	10.29	46.57	66.00	-19.43	QP	
2		0.1500	17.12	10.29	27.41	56.00	-28.59	AVG	
3		0.5140	22.85	11.34	34.19	56.00	-21.81	QP	
4	*	0.5140	15.65	11.34	26.99	46.00	-19.01	AVG	
5		0.9260	5.56	12.20	17.76	46.00	-28.24	AVG	
6		1.3700	15.58	13.13	28.71	56.00	-27.29	QP	
7		3.7420	17.48	10.28	27.76	56.00	-28.24	QP	
8		4.6819	7.94	10.28	18.22	46.00	-27.78	AVG	
9		13.1779	27.48	10.42	37.90	60.00	-22.10	QP	
10		14.5419	18.23	10.48	28.71	50.00	-21.29	AVG	
11		22.2700	13.81	10.74	24.55	50.00	-25.45	AVG	
12		22.5220	23.69	10.74	34.43	60.00	-25.57	QP	

Mode1 / Line: Neutral / CH: L

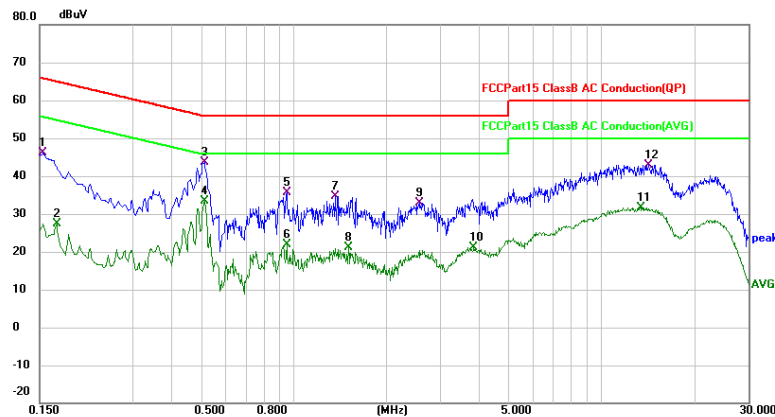

No.	Mk.	Freq.	Reading Level	Correct Factor	Measurement	Limit	Over	Detector	Comment
		MHz	dBuV	dB	dBuV	dBuV	dB		
1		0.1539	35.79	10.28	46.07	65.79	-19.72	QP	
2		0.1700	17.02	10.28	27.30	54.96	-27.66	AVG	
3	*	0.5140	32.23	11.34	43.57	56.00	-12.43	QP	
4		0.5140	21.99	11.34	33.33	46.00	-12.67	AVG	
5		0.9500	23.25	12.31	35.56	56.00	-20.44	QP	
6		0.9500	9.52	12.31	21.83	46.00	-24.17	AVG	
7		1.3619	21.70	12.99	34.69	56.00	-21.31	QP	
8		1.5100	8.00	13.22	21.22	46.00	-24.78	AVG	
9		2.5780	22.77	10.16	32.93	56.00	-23.07	QP	
10		3.8700	10.88	10.27	21.15	46.00	-24.85	AVG	
11		13.4380	21.13	10.47	31.60	50.00	-18.40	AVG	
12		14.2500	32.48	10.49	42.97	60.00	-17.03	QP	

M220

Mode1 / Line: Line / CH: L

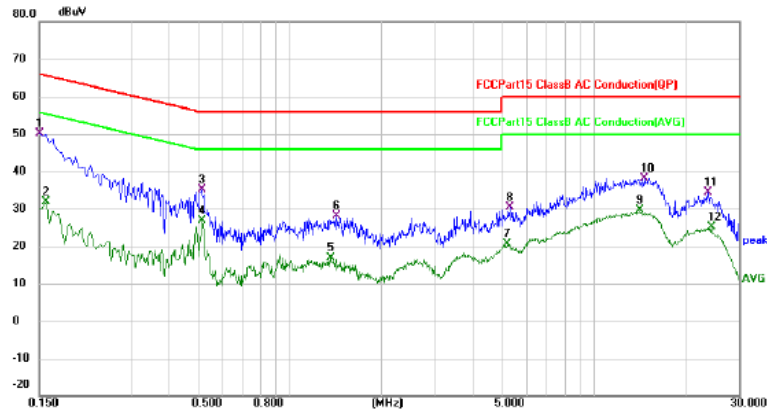

No.	Mk.	Freq.	Reading Level	Correct Factor	Measurement	Limit	Over	Detector	Comment
		MHz	dBuV	dB	dBuV	dBuV	dB		
1	*	0.1500	39.94	10.29	50.23	66.00	-15.77	QP	
2		0.1580	21.66	10.28	31.94	55.57	-23.63	AVG	
3		0.5140	23.82	11.34	35.16	56.00	-20.84	QP	
4		0.5140	15.57	11.34	26.91	46.00	-19.09	AVG	
5		1.3660	3.64	13.13	16.77	46.00	-29.23	AVG	
6		1.4180	14.82	13.23	28.05	56.00	-27.95	QP	
7		5.2179	10.44	10.27	20.71	50.00	-29.29	AVG	
8		5.2938	20.13	10.27	30.40	60.00	-29.60	QP	
9		14.2100	19.06	10.46	29.52	50.00	-20.48	AVG	
10		14.7100	27.76	10.48	38.24	60.00	-21.76	QP	
11		23.6700	23.73	10.76	34.49	60.00	-25.51	QP	
12		24.2939	14.27	10.77	25.04	50.00	-24.96	AVG	

Mode1 / Line: Neutral / CH: L

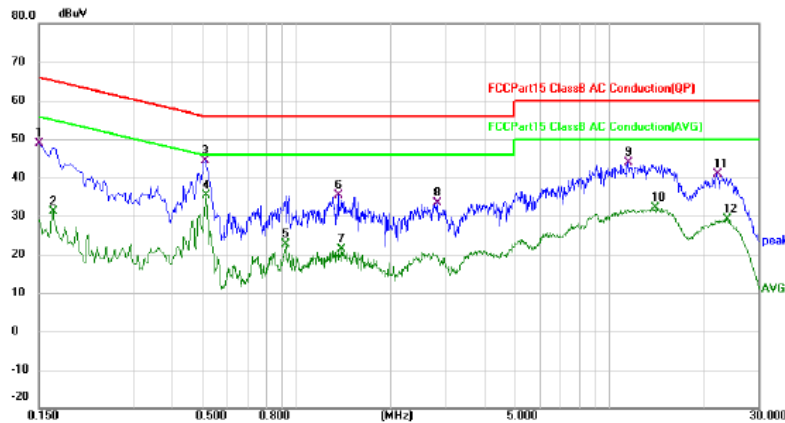

No.	Mk.	Freq.	Reading Level	Correct Factor	Measurement	Limit	Over	Detector	Comment
		MHz	dBuV	dB	dBuV	dBuV	dB		
1		0.1500	38.61	10.28	48.89	66.00	-17.11	QP	
2		0.1660	20.87	10.28	31.15	55.16	-24.01	AVG	
3		0.5100	33.12	11.34	44.46	56.00	-11.54	QP	
4	*	0.5140	23.92	11.34	35.26	46.00	-10.74	AVG	
5		0.9260	10.43	12.25	22.68	46.00	-23.32	AVG	
6		1.3619	22.39	12.99	35.38	56.00	-20.62	QP	
7		1.3900	8.36	13.03	21.39	46.00	-24.61	AVG	
8		2.8260	23.08	10.23	33.31	56.00	-22.69	QP	
9		11.4420	33.42	10.43	43.85	60.00	-16.15	QP	
10		14.0580	21.60	10.49	32.09	50.00	-17.91	AVG	
11		22.1620	30.18	10.71	40.89	60.00	-19.11	QP	
12		23.7180	18.27	10.74	29.01	50.00	-20.99	AVG	

M221

Mode1 / Line: Line / CH: L

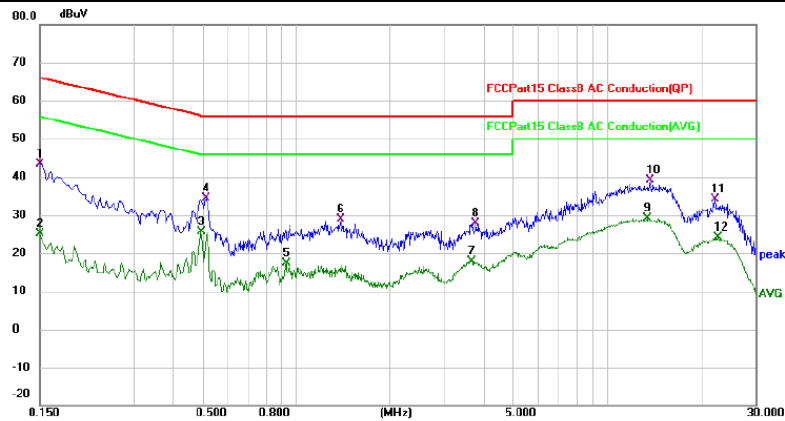

No.	Mk.	Freq.	Reading Level	Correct Factor	Measurement	Limit	Over	Detector	Comment
		MHz	dBuV	dB	dBuV	dBuV	dB		
1		0.1500	33.10	10.28	43.38	66.00	-22.62	QP	
2		0.1500	14.82	10.28	25.10	56.00	-30.90	AVG	
3	*	0.4940	14.33	11.30	25.63	46.10	-20.47	AVG	
4		0.5140	22.97	11.34	34.31	56.00	-21.69	QP	
5		0.9300	5.10	12.26	17.36	46.00	-28.64	AVG	
6		1.3900	15.75	13.03	28.78	56.00	-27.22	QP	
7		3.6700	7.64	10.27	17.91	46.00	-28.09	AVG	
8		3.7820	17.54	10.27	27.81	56.00	-28.19	QP	
9		13.4620	18.65	10.47	29.12	50.00	-20.88	AVG	
10		13.7620	28.72	10.49	39.21	60.00	-20.79	QP	
11		22.2700	23.37	10.72	34.09	60.00	-25.91	QP	
12		22.7740	13.37	10.72	24.09	50.00	-25.91	AVG	

Mode1 / Line: Neutral / CH: L

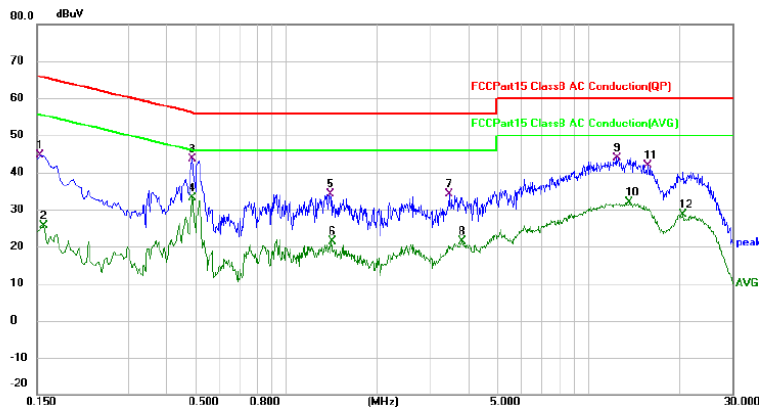

No.	Mk.	Freq.	Reading Level	Correct Factor	Measurement	Limit	Over	Detector	Comment
		MHz	dBuV	dB	dBuV	dBuV	dB		
1		0.1539	34.23	10.28	44.51	65.79	-21.28	QP	
2		0.1580	15.23	10.28	25.51	55.57	-30.06	AVG	
3	*	0.4900	32.43	11.30	43.73	56.17	-12.44	QP	
4		0.4900	21.83	11.30	33.13	46.17	-13.04	AVG	
5		1.3980	21.16	13.04	34.20	56.00	-21.80	QP	
6		1.4180	8.36	13.08	21.44	46.00	-24.56	AVG	
7		3.4660	23.95	10.27	34.22	56.00	-21.78	QP	
8		3.8300	11.19	10.27	21.46	46.00	-24.54	AVG	
9		12.4339	33.50	10.45	43.95	60.00	-16.05	QP	
10		13.6900	21.31	10.49	31.80	50.00	-18.20	AVG	
11		15.7339	31.45	10.53	41.98	60.00	-18.02	QP	
12		20.6380	17.97	10.67	28.64	50.00	-21.36	AVG	

M250

Mode1 / Line: Line / CH: L

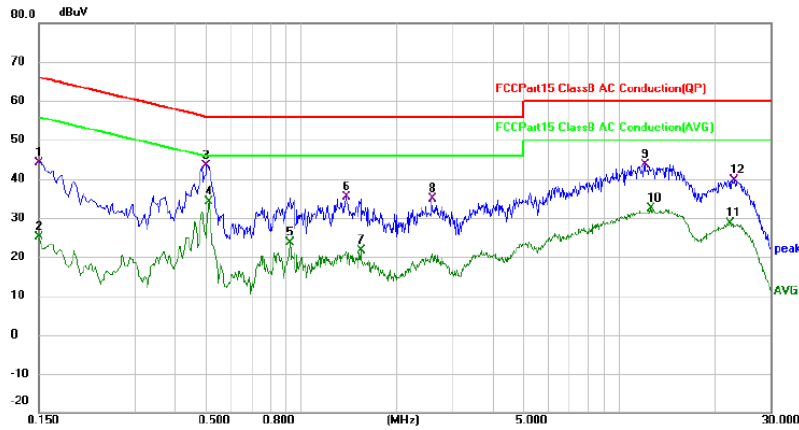

No.	Mk.	Freq.	Reading Level	Correct Factor	Measurement	Limit	Over	Detector	Comment
		MHz	dBuV	dB	dBuV	dBuV	dB		
1		0.1500	33.78	10.28	44.06	66.00	-21.94	QP	
2		0.1500	14.96	10.28	25.24	56.00	-30.76	AVG	
3		0.5060	32.07	11.34	43.41	56.00	-12.59	QP	
4	*	0.5140	22.69	11.34	34.03	46.00	-11.97	AVG	
5		0.9260	11.33	12.25	23.58	46.00	-22.42	AVG	
6		1.3860	22.23	13.03	35.26	56.00	-20.74	QP	
7		1.5460	8.37	13.29	21.66	46.00	-24.34	AVG	
8		2.5820	24.83	10.16	34.99	56.00	-21.01	QP	
9		12.0778	33.12	10.45	43.57	60.00	-16.43	QP	
10		12.5819	22.02	10.47	32.49	50.00	-17.51	AVG	
11		22.5060	17.81	10.71	28.52	50.00	-21.48	AVG	
12		23.1020	28.96	10.72	39.68	60.00	-20.32	QP	

Mode1 / Line: Neutral / CH: L

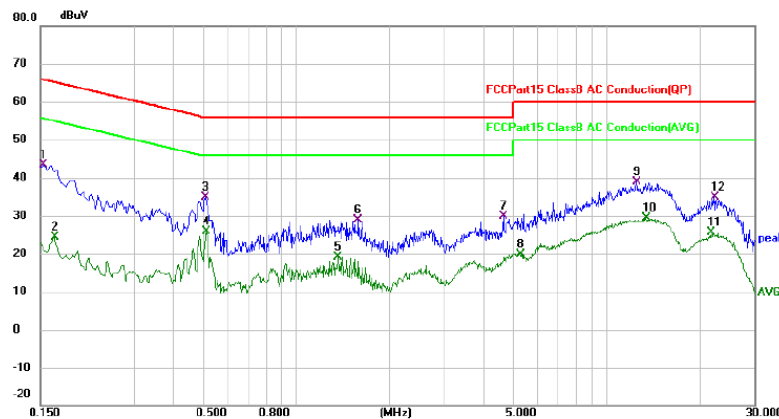

No.	Mk.	Freq.	Reading Level	Correct Factor	Measurement	Limit	Over	Detector	Comment
		MHz	dBuV	dB	dBuV	dBuV	dB		
1		0.1539	32.98	10.28	43.26	65.79	-22.53	QP	
2		0.1660	14.21	10.26	24.47	55.16	-30.69	AVG	
3		0.5100	23.54	11.34	34.88	56.00	-21.12	QP	
4	*	0.5140	14.58	11.34	25.92	46.00	-20.08	AVG	
5		1.3700	5.99	13.13	19.12	46.00	-26.88	AVG	
6		1.5900	15.31	13.60	28.91	56.00	-27.09	QP	
7		4.6700	19.60	10.28	29.88	56.00	-26.12	QP	
8		5.2660	9.72	10.27	19.99	50.00	-30.01	AVG	
9		12.4780	28.41	10.39	38.80	60.00	-21.20	QP	
10		13.4020	18.88	10.43	29.31	50.00	-20.69	AVG	
11		21.8180	14.90	10.73	25.63	50.00	-24.37	AVG	
12		22.1940	24.06	10.74	34.80	60.00	-25.20	QP	

M260

Mode1 / Line: Line / CH: L

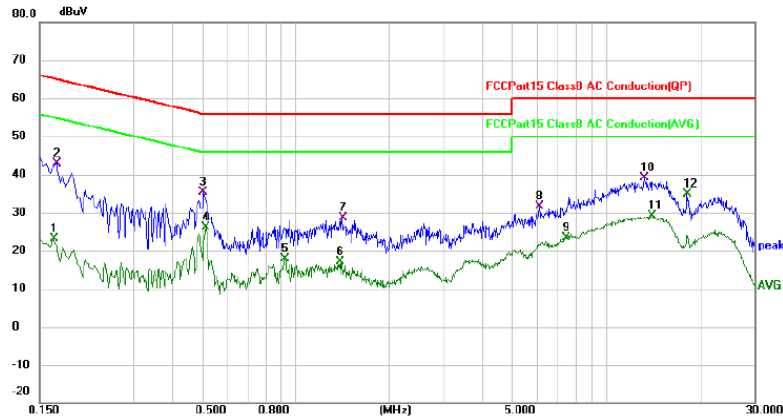

No.	Mk.	Freq.	Reading Level	Correct Factor	Measurement	Limit	Over	Detector	Comment
		MHz	dBuV	dB	dBuV	dBuV	dB		
1		0.1660	12.90	10.26	23.16	55.16	-32.00	AVG	
2		0.1700	32.73	10.26	42.99	64.96	-21.97	QP	
3		0.5060	23.94	11.34	35.28	56.00	-20.72	QP	
4		0.5140	14.88	11.34	26.22	46.00	-19.78	AVG	
5		0.9260	5.80	12.20	18.00	46.00	-28.00	AVG	
6		1.3900	3.91	13.16	17.07	46.00	-28.93	AVG	
7		1.4180	15.38	13.23	28.61	56.00	-27.39	QP	
8		6.0979	21.38	10.28	31.66	60.00	-28.34	QP	
9		7.4339	13.01	10.29	23.30	50.00	-26.70	AVG	
10		13.2939	28.67	10.43	39.10	60.00	-20.90	QP	
11		13.9659	18.67	10.45	29.12	50.00	-20.88	AVG	
12	*	18.2259	24.24	10.62	34.86	50.00	-15.14	AVG	

Mode1 / Line: Neutral / CH: L

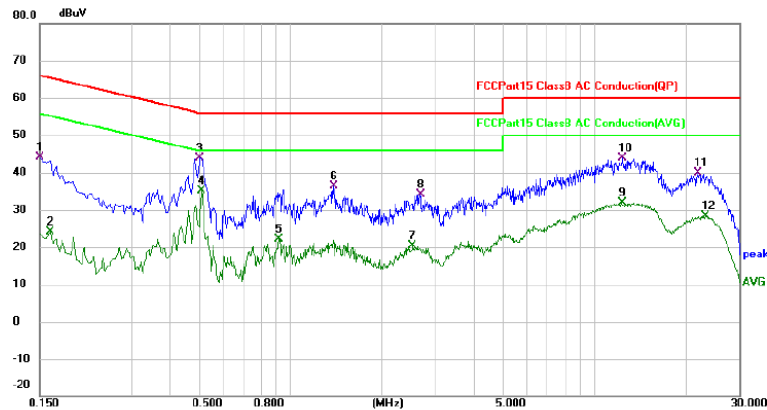

No.	Mk.	Freq.	Reading Level	Correct Factor	Measurement	Limit	Over	Detector	Comment
		MHz	dBuV	dB	dBuV	dBuV	dB		
1		0.1500	33.80	10.29	44.09	66.00	-21.91	QP	
2		0.1620	13.79	10.27	24.06	55.36	-31.30	AVG	
3		0.5060	32.50	11.34	43.84	56.00	-12.16	QP	
4	*	0.5100	23.88	11.34	35.22	46.00	-10.78	AVG	
5		0.9220	9.90	12.18	22.08	46.00	-23.92	AVG	
6		1.3860	23.22	13.16	36.38	56.00	-19.62	QP	
7		2.5300	10.06	10.38	20.44	46.00	-25.56	AVG	
8		2.6780	23.78	10.35	34.13	56.00	-21.87	QP	
9		12.3060	21.39	10.39	31.78	50.00	-18.22	AVG	
10		12.4379	33.48	10.39	43.87	60.00	-16.13	QP	
11		21.9860	29.04	10.74	39.78	60.00	-20.22	QP	
12		23.2420	17.71	10.76	28.47	50.00	-21.53	AVG	

6.2 Occupied Bandwidth

Test Requirement:	47 CFR 15.215(c)
Test Limit:	Refer to 47 CFR 15.215(c), intentional radiators operating under the alternative provisions to the general emission limits, as contained in §§ 15.217 through 15.257 and in subpart E of this part, must be designed to ensure that the 20 dB bandwidth of the emission, or whatever bandwidth may otherwise be specified in the specific rule section under which the equipment operates, is contained within the frequency band designated in the rule section under which the equipment is operated.
Test Method:	ANSI C63.10-2020, section 7.8.7, For occupied bandwidth measurements, use the procedure in 6.9.2. KDB 558074 D01 15.247 Meas Guidance v05r02
Procedure:	<p>a) The spectrum analyzer center frequency is set to the nominal EUT channel center frequency. The span range for the EMI receiver or spectrum analyzer shall be between two times and five times the OBW.</p> <p>b) The nominal IF filter bandwidth (3 dB RBW) shall be in the range of 1% to 5% of the OBW and video bandwidth (VBW) shall be approximately three times RBW, unless otherwise specified by the applicable requirement.</p> <p>c) Set the reference level of the instrument as required, keeping the signal from exceeding the maximum input mixer level for linear operation. In general, the peak of the spectral envelope shall be more than $[10 \log (OBW/RBW)]$ below the reference level. Specific guidance is given in 4.1.5.2.</p> <p>d) Steps a) through c) might require iteration to adjust within the specified tolerances.</p> <p>e) The dynamic range of the instrument at the selected RBW shall be more than 10 dB below the target “-xx dB down” requirement; that is, if the requirement calls for measuring the -20 dB OBW, the instrument noise floor at the selected RBW shall be at least 30 dB below the reference value.</p> <p>f) Set detection mode to peak and trace mode to max hold.</p> <p>g) Determine the reference value: Set the EUT to transmit an unmodulated carrier or modulated signal, as applicable. Allow the trace to stabilize. Set the spectrum analyzer marker to the highest level of the displayed trace (this is the reference value).</p> <p>h) Determine the “-xx dB down amplitude” using $[(\text{reference value}) - xx]$. Alternatively, this calculation may be made by using the marker-delta function of the instrument.</p> <p>i) If the reference value is determined by an unmodulated carrier, then turn the EUT modulation ON, and either clear the existing trace or start a new trace on the spectrum analyzer and allow the new trace to stabilize. Otherwise, the trace from step g) shall be used for step j).</p> <p>j) Place two markers, one at the lowest frequency and the other at the highest frequency of the envelope of the spectral display, such that each marker is at or slightly below the “-xx dB down amplitude” determined in step h). If a marker is below this “-xx dB down amplitude” value, then it shall be as close as possible to this value. The occupied bandwidth is the frequency difference between the two markers. Alternatively, set a marker at the lowest frequency of the envelope of the spectral display, such that the marker is at or slightly below the “-xx dB down amplitude” determined in step h). Reset the marker-delta function and move the marker to the other side of the emission until the delta marker amplitude is at the same level as the reference marker amplitude. The marker-delta frequency reading at this point is the specified emission bandwidth.</p> <p>k) The occupied bandwidth shall be reported by providing plot(s) of the measuring instrument display; the plot axes and the scale units per division shall be clearly labeled. Tabular data may be reported in addition to the</p>

	plot(s).
--	----------

6.2.1 E.U.T. Operation:

Operating Environment:					
Temperature:	25 °C	Humidity:	56 %	Atmospheric Pressure:	100 kPa
Pre test mode:	Mode1, Mode2				
Final test mode:	Mode1, Mode2				

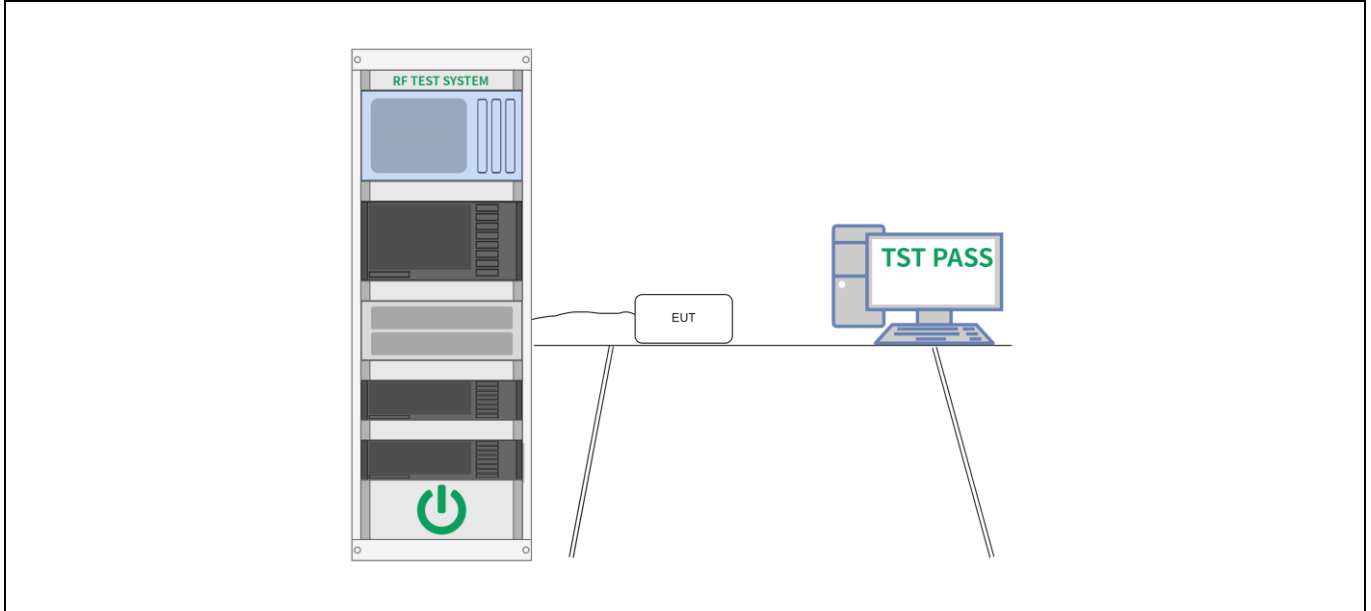
6.2.2 Test Setup Diagram:

6.2.3 Test Data:

Please Refer to Appendix for Details.

6.3 Maximum Conducted Output Power

Test Requirement:	47 CFR 15.247(b)(1)
Test Limit:	Refer to 47 CFR 15.247(b)(1), For frequency hopping systems operating in the 2400-2483.5 MHz band employing at least 75 non-overlapping hopping channels, and all frequency hopping systems in the 5725-5850 MHz band: 1 watt. For all other frequency hopping systems in the 2400-2483.5 MHz band: 0.125 watts.
Test Method:	ANSI C63.10-2020, section 7.8.5 KDB 558074 D01 15.247 Meas Guidance v05r02
Procedure:	<p>This is an RF-conducted test to evaluate maximum peak output power. Use a direct connection between the antenna port of the unlicensed wireless device and the spectrum analyzer, through suitable attenuation. The hopping shall be disabled for this test:</p> <p>a) Use the following spectrum analyzer settings:</p> <ol style="list-style-type: none"> 1) Span: Approximately five times the 20 dB bandwidth, centered on a hopping channel. 2) RBW > 20 dB bandwidth of the emission being measured. 3) VBW >= RBW. 4) Sweep: Auto. 5) Detector function: Peak. 6) Trace: Max hold. <p>b) Allow trace to stabilize.</p> <p>c) Use the marker-to-peak function to set the marker to the peak of the emission.</p> <p>d) The indicated level is the peak output power, after any corrections for external attenuators and cables.</p> <p>e) A plot of the test results and setup description shall be included in the test report.</p> <p>NOTE—A peak responding power meter may be used, where the power meter and sensor system video bandwidth is greater than the occupied bandwidth of the unlicensed wireless device, rather than a spectrum analyzer.</p>

6.3.1 E.U.T. Operation:

Operating Environment:			
Temperature:	25 °C	Humidity:	56 %
Atmospheric Pressure:		100 kPa	
Pre test mode:	Mode1, Mode2		
Final test mode:	Mode1, Mode2		

6.3.2 Test Setup Diagram:

--

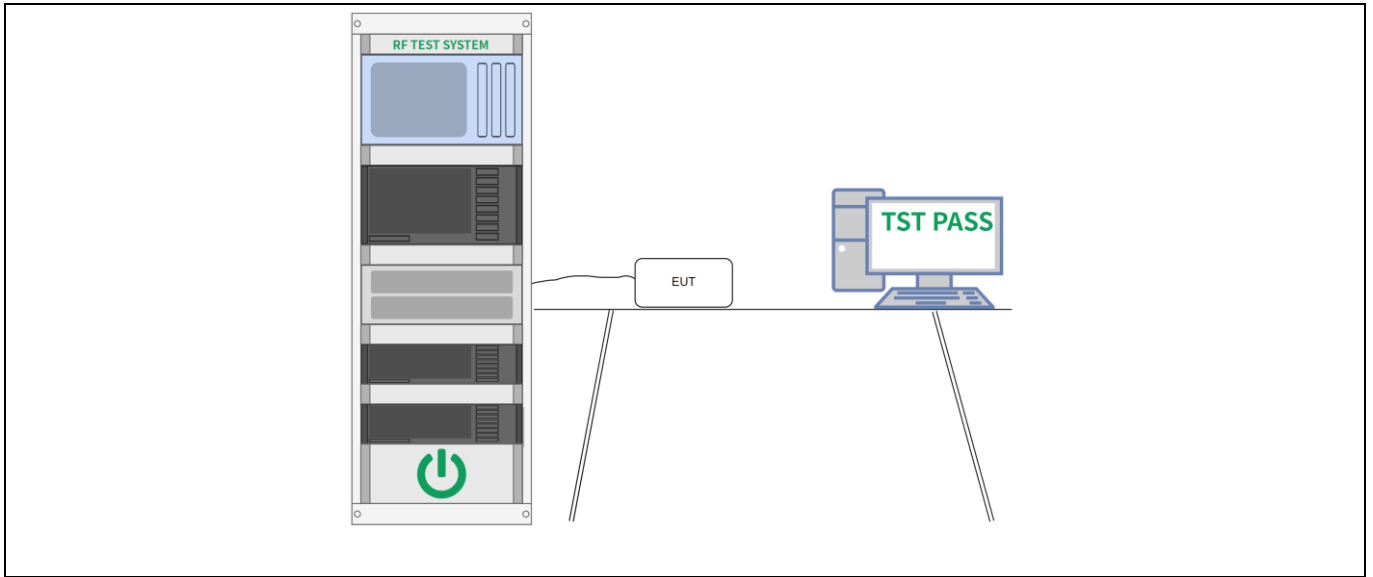

6.3.3 Test Data:

Please Refer to Appendix for Details.

6.4 Channel Separation

Test Requirement:	47 CFR 15.247(a)(1)
Test Limit:	Refer to 47 CFR 15.247(a)(1), Frequency hopping systems shall have hopping channel carrier frequencies separated by a minimum of 25 kHz or the 20 dB bandwidth of the hopping channel, whichever is greater. Alternatively, frequency hopping systems operating in the 2400-2483.5 MHz band may have hopping channel carrier frequencies that are separated by 25 kHz or two-thirds of the 20 dB bandwidth of the hopping channel, whichever is greater, provided the systems operate with an output power no greater than 125 mW.
Test Method:	ANSI C63.10-2020, section 7.8.2 KDB 558074 D01 15.247 Meas Guidance v05r02
Procedure:	The EUT shall have its hopping function enabled. Use the following spectrum analyzer settings: a) Span: Wide enough to capture the peaks of two adjacent channels. b) RBW: Start with the RBW set to approximately 30% of the channel spacing; adjust as necessary to best identify the center of each individual channel. c) Video (or average) bandwidth (VBW) \geq RBW. d) Sweep: Auto. e) Detector function: Peak. f) Trace: Max hold. g) Allow the trace to stabilize. Use the marker-delta function to determine the separation between the peaks of the adjacent channels. Compliance of an EUT with the appropriate regulatory limit shall be determined. A plot of the data shall be included in the test report.

6.4.1 E.U.T. Operation:

Operating Environment:					
Temperature:	25 °C	Humidity:	56 %	Atmospheric Pressure:	100 kPa
Pre test mode:	Mode1, Mode2				
Final test mode:	Mode1, Mode2				

6.4.2 Test Setup Diagram:

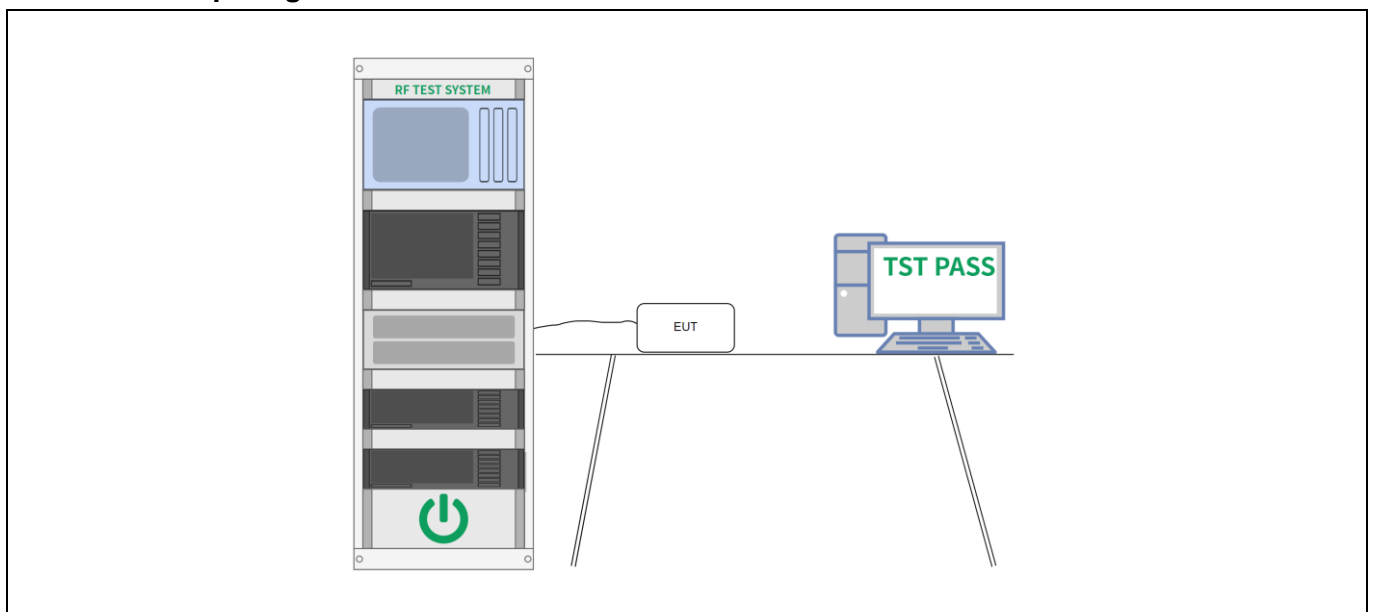

6.4.3 Test Data:

Please Refer to Appendix for Details.

6.5 Number of Hopping Frequencies

Test Requirement:	47 CFR 15.247(a)(1)(iii)
Test Limit:	Refer to 47 CFR 15.247(a)(1)(iii), Frequency hopping systems in the 2400-2483.5 MHz band shall use at least 15 channels. The average time of occupancy on any channel shall not be greater than 0.4 seconds within a period of 0.4 seconds multiplied by the number of hopping channels employed. Frequency hopping systems may avoid or suppress transmissions on a particular hopping frequency provided that a minimum of 15 channels are used.
Test Method:	ANSI C63.10-2020, section 7.8.3 KDB 558074 D01 15.247 Meas Guidance v05r02
Procedure:	<p>The EUT shall have its hopping function enabled. Use the following spectrum analyzer settings:</p> <ul style="list-style-type: none"> a) Span: The frequency band of operation. Depending on the number of channels the device supports, it may be necessary to divide the frequency range of operation across multiple spans, to allow the individual channels to be clearly seen. b) RBW: To identify clearly the individual channels, set the RBW to less than 30% of the channel spacing or the 20 dB bandwidth, whichever is smaller. c) VBW \geq RBW. d) Sweep: Auto. e) Detector function: Peak. f) Trace: Max hold. g) Allow the trace to stabilize. <p>It might prove necessary to break the span up into subranges to show clearly all of the hopping frequencies. Compliance of an EUT with the appropriate regulatory limit shall be determined for the number of hopping channels. A plot of the data shall be included in the test report.</p>

6.5.1 E.U.T. Operation:

Operating Environment:					
Temperature:	25 °C	Humidity:	56 %	Atmospheric Pressure:	100 kPa
Pre test mode:	Mode1, Mode2				
Final test mode:	Mode1, Mode2				

6.5.2 Test Setup Diagram:

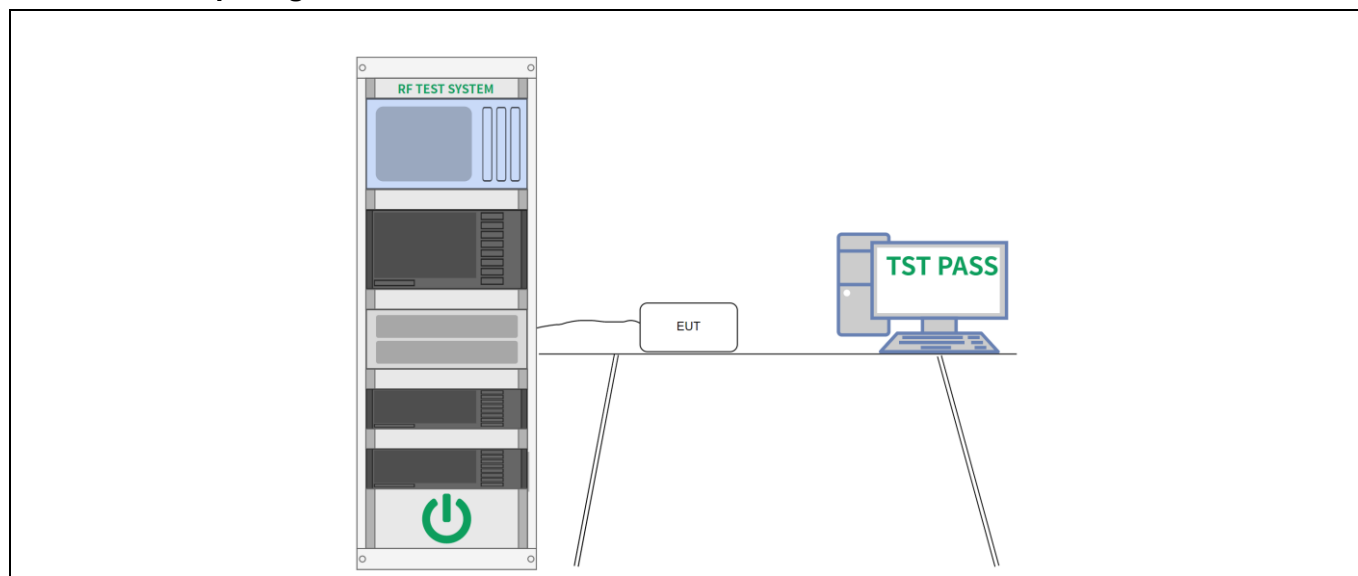

6.5.3 Test Data:

Please Refer to Appendix for Details.

6.6 Dwell Time

Test Requirement:	47 CFR 15.247(a)(1)(iii)
Test Limit:	Refer to 47 CFR 15.247(a)(1)(iii), Frequency hopping systems in the 2400-2483.5 MHz band shall use at least 15 channels. The average time of occupancy on any channel shall not be greater than 0.4 seconds within a period of 0.4 seconds multiplied by the number of hopping channels employed. Frequency hopping systems may avoid or suppress transmissions on a particular hopping frequency provided that a minimum of 15 channels are used.
Test Method:	ANSI C63.10-2020, section 7.8.4 KDB 558074 D01 15.247 Meas Guidance v05r02
Procedure:	<p>The EUT shall have its hopping function enabled. Use the following spectrum analyzer settings:</p> <p>a) Span: Zero span, centered on a hopping channel.</p> <p>b) RBW shall be \leq channel spacing and where possible RBW should be set $\gg 1 / T$, where T is the expected dwell time per channel.</p> <p>c) Sweep: As necessary to capture the entire dwell time per hopping channel; where possible use a video trigger and trigger delay so that the transmitted signal starts a little to the right of the start of the plot. The trigger level might need slight adjustment to prevent triggering when the system hops on an adjacent channel; a second plot might be needed with a longer sweep time to show two successive hops on a channel.</p> <p>d) Detector function: Peak.</p> <p>e) Trace: Max hold.</p> <p>Use the marker-delta function to determine the transmit time per hop. If this value varies with different modes of operation (data rate, modulation format, number of hopping channels, etc.), then repeat this test for each variation in transmit time.</p> <p>Repeat the measurement using a longer sweep time to determine the number of hops over the period specified in the requirements. The sweep time shall be equal to, or less than, the period specified in the requirements. Determine the number of hops over the sweep time and calculate the total number of hops in the period specified in the requirements, using the following equation:</p> $(\text{Number of hops in the period specified in the requirements}) = (\text{number of hops on spectrum analyzer}) \times (\text{period specified in the requirements} / \text{analyzer sweep time})$ <p>The average time of occupancy is calculated from the transmit time per hop multiplied by the number of hops in the period specified in the requirements. If the number of hops in a specific time varies with different modes of operation (data rate, modulation format, number of hopping channels, etc.), then repeat this test for each variation.</p> <p>The measured transmit time and time between hops shall be consistent with the values described in the operational description for the EUT.</p>

6.6.1 E.U.T. Operation:

Operating Environment:					
Temperature:	25 °C	Humidity:	56 %	Atmospheric Pressure:	100 kPa
Pre test mode:	Mode1, Mode2				
Final test mode:	Mode1, Mode2				

6.6.2 Test Setup Diagram:

--

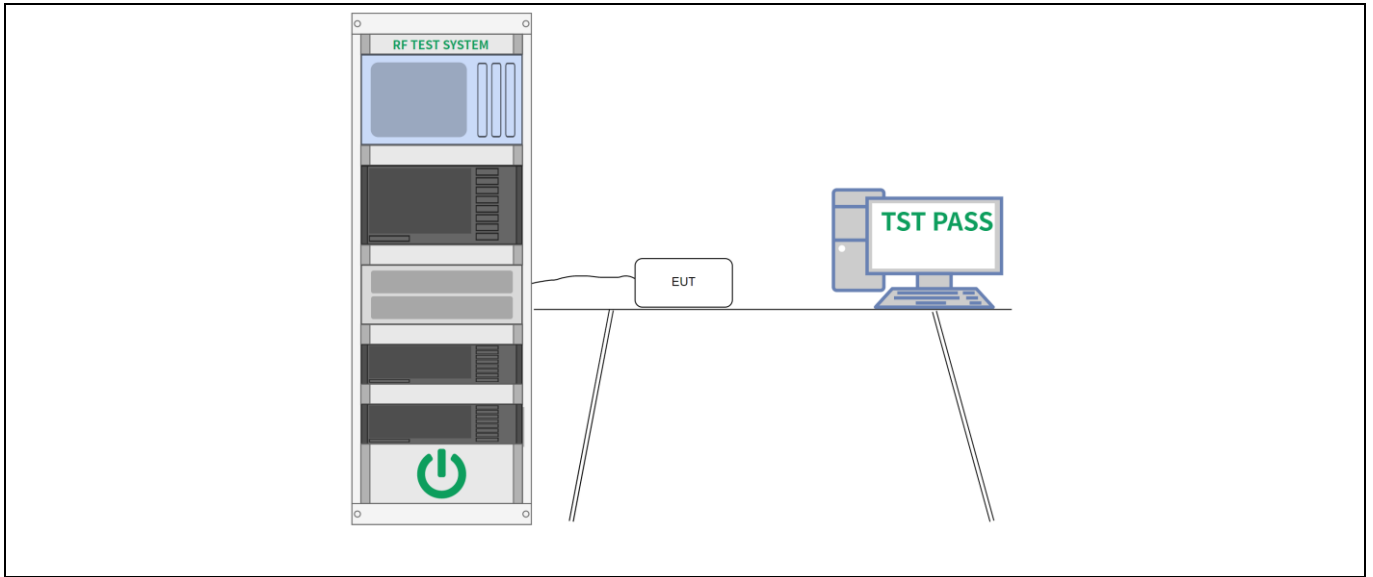

6.6.3 Test Data:

Please Refer to Appendix for Details.

6.7 RF conducted spurious emissions and band edge measurement

Test Requirement:	47 CFR 15.247(d), 15.209, 15.205
Test Limit:	Refer to 47 CFR 15.247(d), In any 100 kHz bandwidth outside the frequency band in which the spread spectrum or digitally modulated intentional radiator is operating, the radio frequency power that is produced by the intentional radiator shall be at least 20 dB below that in the 100 kHz bandwidth within the band that contains the highest level of the desired power, based on either an RF conducted or a radiated measurement, provided the transmitter demonstrates compliance with the peak conducted power limits. If the transmitter complies with the conducted power limits based on the use of RMS averaging over a time interval, as permitted under paragraph (b)(3) of this section, the attenuation required under this paragraph shall be 30 dB instead of 20 dB. Attenuation below the general limits specified in § 15.209(a) is not required.
Test Method:	ANSI C63.10-2020 section 7.8.8 KDB 558074 D01 15.247 Meas Guidance v05r02
Procedure:	Conducted spurious emissions shall be measured for the transmit frequency, per 5.5 and 5.6, and at the maximum transmit powers. Connect the primary antenna port through an attenuator to the spectrum analyzer input; in the results, account for all losses between the unlicensed wireless device output and the spectrum analyzer. The instrument shall span 30 MHz to 10 times the operating frequency in GHz, with a resolution bandwidth of 100 kHz, video bandwidth of 300 kHz, and a coupled sweep time with a peak detector. The band 30 MHz to the highest frequency may be split into smaller spans, as long as the entire spectrum is covered.

6.7.1 E.U.T. Operation:

Operating Environment:			
Temperature:	25 °C	Humidity:	56 %
Atmospheric Pressure:		100 kPa	
Pre test mode:	Mode1, Mode2		
Final test mode:	Mode1, Mode2		

6.7.2 Test Setup Diagram:

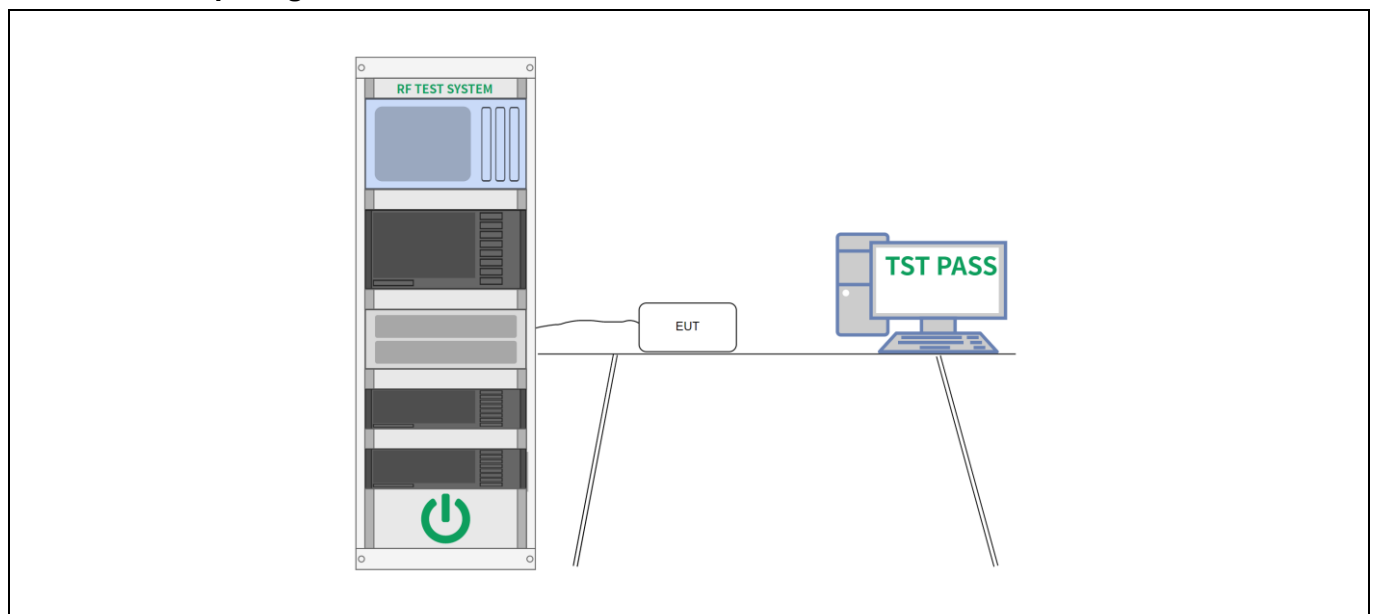

6.7.3 Test Data:

Please Refer to Appendix for Details.

6.8 Band edge emissions (Radiated)

Test Requirement:	Refer to 47 CFR 15.247(d), In addition, radiated emissions which fall in the restricted bands, as defined in § 15.205(a), must also comply with the radiated emission limits specified in § 15.209(a)(see § 15.205(c)).`		
Test Limit:	Frequency (MHz)	Field strength (microvolts/meter)	Measurement distance (meters)
	0.009-0.490	2400/F(kHz)	300
	0.490-1.705	24000/F(kHz)	30
	1.705-30.0	30	30
	30-88	100 **	3
	88-216	150 **	3
	216-960	200 **	3
	Above 960	500	3
	** Except as provided in paragraph (g), fundamental emissions from intentional radiators operating under this section shall not be located in the frequency bands 54-72 MHz, 76-88 MHz, 174-216 MHz or 470-806 MHz. However, operation within these frequency bands is permitted under other sections of this part, e.g., §§ 15.231 and 15.241. In the emission table above, the tighter limit applies at the band edges. The emission limits shown in the above table are based on measurements employing a CISPR quasi-peak detector except for the frequency bands 9–90 kHz, 110–490 kHz and above 1000 MHz. Radiated emission limits in these three bands are based on measurements employing an average detector.		
Test Method:	ANSI C63.10-2020 section 6.10 KDB 558074 D01 15.247 Meas Guidance v05r02		
Procedure:	ANSI C63.10-2020 section 6.10.5.2		

6.8.1 E.U.T. Operation:

Operating Environment:			
Temperature:	24 °C	Humidity:	54 %
		Atmospheric Pressure:	101 kPa
Pre test mode:	Mode1, Mode2		
Final test mode:	All of the listed pre-test mode were tested, only the data of the worst mode (Mode2) is recorded in the report		
Note:	The amplitude of spurious emissions which are attenuated more than 20 dB below the limits are not reported.		

6.8.2 Test Setup Diagram:

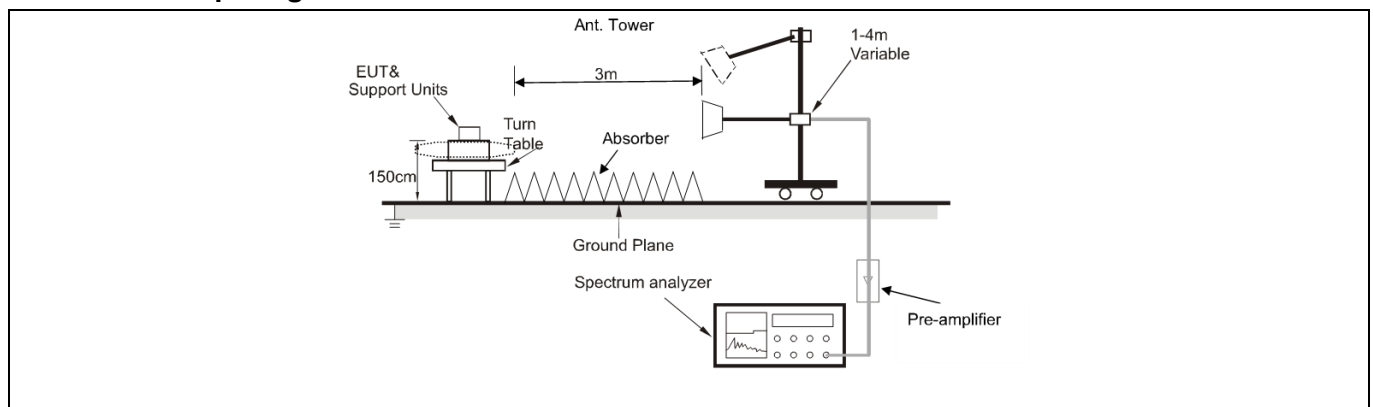

6.8.3 Test Data:

Mode2 / Polarization: Horizontal / CH: L

No. Mk.	Freq.	Reading Level	Correct Factor	Measurement	Limit	Over	Detector
	MHz	dBuV	dB	dBuV/m	dBuV/m	dB	
1	2310.000	52.69	-12.92	39.77	74.00	-34.23	peak
2	2310.000	41.64	-12.92	28.72	54.00	-25.28	AVG
3	2390.000	56.03	-12.49	43.54	74.00	-30.46	peak
4 *	2390.000	46.08	-12.49	33.59	54.00	-20.41	AVG

Mode2 / Polarization: Vertical / CH: L

No. Mk.	Freq.	Reading Level	Correct Factor	Measurement	Limit	Over	Detector
	MHz	dBuV	dB	dBuV/m	dBuV/m	dB	
1	2310.000	50.73	-12.92	37.81	74.00	-36.19	peak
2	2310.000	42.57	-12.92	29.65	54.00	-24.35	AVG
3	2390.000	55.05	-12.49	42.56	74.00	-31.44	peak
4 *	2390.000	44.75	-12.49	32.26	54.00	-21.74	AVG

Mode2 / Polarization: Horizontal / CH: H

No. Mk.	Freq.	Reading Level	Correct Factor	Measurement	Limit	Over	Detector
	MHz	dBuV	dB	dBuV/m	dBuV/m	dB	
1	2483.500	56.11	-12.50	43.61	74.00	-30.39	peak
2	2483.500	43.57	-12.50	31.07	54.00	-22.93	AVG
3	2500.000	53.79	-12.41	41.38	74.00	-32.62	peak
4 *	2500.000	43.88	-12.41	31.47	54.00	-22.53	AVG

Mode2 / Polarization: Vertical / CH: H

No. Mk.	Freq.	Reading Level	Correct Factor	Measurement	Limit	Over	Detector
	MHz	dBuV	dB	dBuV/m	dBuV/m	dB	
1	2483.500	60.45	-12.50	47.95	74.00	-26.05	peak
2	2483.500	43.77	-12.50	31.27	54.00	-22.73	AVG
3	2500.000	55.59	-12.41	43.18	74.00	-30.82	peak
4 *	2500.000	45.35	-12.41	32.94	54.00	-21.06	AVG

6.9 Radiated emissions (below 1GHz)

Test Requirement:	Refer to 47 CFR 15.247(d), In addition, radiated emissions which fall in the restricted bands, as defined in § 15.205(a), must also comply with the radiated emission limits specified in § 15.209(a)(see § 15.205(c)).`		
Test Limit:	Frequency (MHz)	Field strength (microvolts/meter)	Measurement distance (meters)
	0.009-0.490	2400/F(kHz)	300
	0.490-1.705	24000/F(kHz)	30
	1.705-30.0	30	30
	30-88	100 **	3
	88-216	150 **	3
	216-960	200 **	3
	Above 960	500	3
	** Except as provided in paragraph (g), fundamental emissions from intentional radiators operating under this section shall not be located in the frequency bands 54-72 MHz, 76-88 MHz, 174-216 MHz or 470-806 MHz. However, operation within these frequency bands is permitted under other sections of this part, e.g., §§ 15.231 and 15.241. In the emission table above, the tighter limit applies at the band edges. The emission limits shown in the above table are based on measurements employing a CISPR quasi-peak detector except for the frequency bands 9–90 kHz, 110–490 kHz and above 1000 MHz. Radiated emission limits in these three bands are based on measurements employing an average detector.		
Test Method:	ANSI C63.10-2020 section 6.6.4 KDB 558074 D01 15.247 Meas Guidance v05r02		
Procedure:	ANSI C63.10-2020 section 6.6.4		

6.9.1 E.U.T. Operation:

Operating Environment:			
Temperature:	24 °C	Humidity:	54 %
		Atmospheric Pressure:	101 kPa
Pre test mode:	Mode1, Mode2		
Final test mode:	All of the listed pre-test mode were tested, only the data of the worst mode (Mode2) is recorded in the report		
Note:	The amplitude of spurious emissions which are attenuated more than 20 dB below the limits are not reported. All modes of operation of the EUT were investigated, and only the worst-case results are reported. There were no emissions found below 30MHz within 20dB of the limit.		

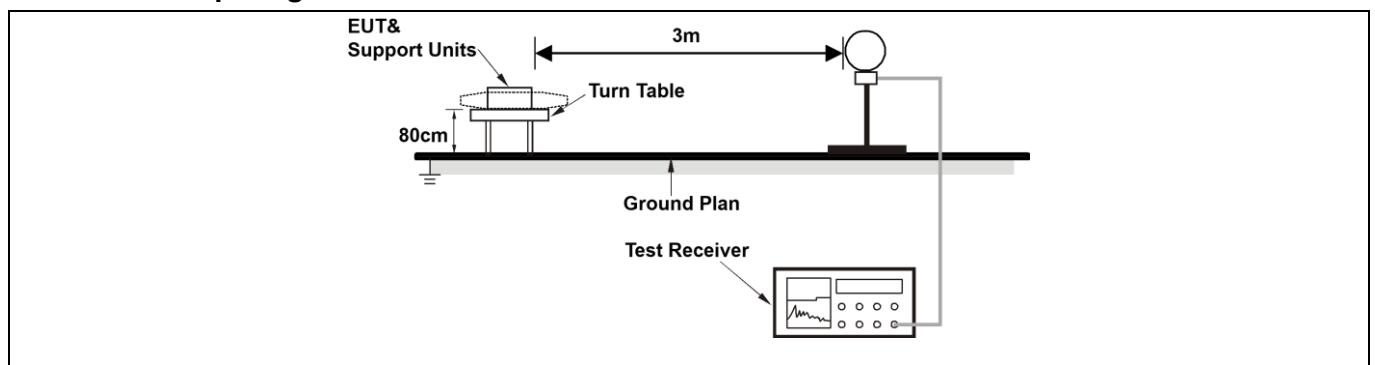
6.9.2 Test Setup Diagram:

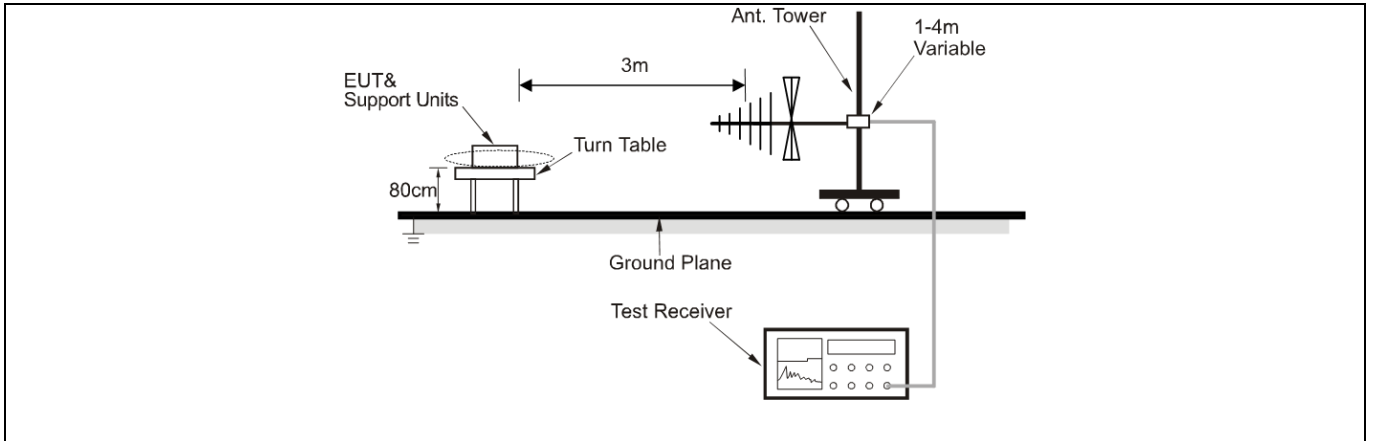

6.9.3 Test Data:

M200

Mode2 / Polarization: Horizontal / CH: H

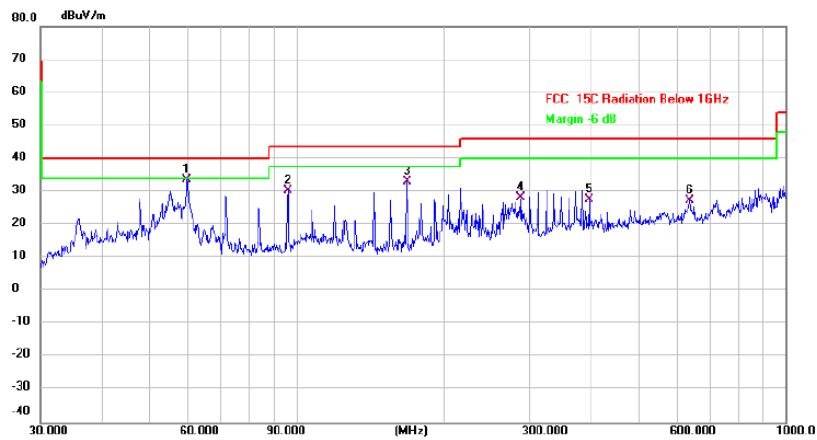

No.	Mk.	Freq.	Reading Level	Correct Factor	Measurement	Limit	Over	Detector	Comment
		MHz	dBuV	dB	dBuV/m	dBuV/m	dB		
1	*	59.8588	43.41	-9.79	33.62	40.00	-6.38	QP	
2		96.0986	41.01	-10.55	30.46	43.50	-13.04	QP	
3		167.8243	44.17	-11.01	33.16	43.50	-10.34	QP	
4		287.9904	33.70	-5.60	28.10	46.00	-17.90	QP	
5		396.2415	32.64	-4.97	27.67	46.00	-18.33	QP	
6		636.1340	27.46	-0.14	27.32	46.00	-18.68	QP	

Mode2 / Polarization: Vertical / CH: H

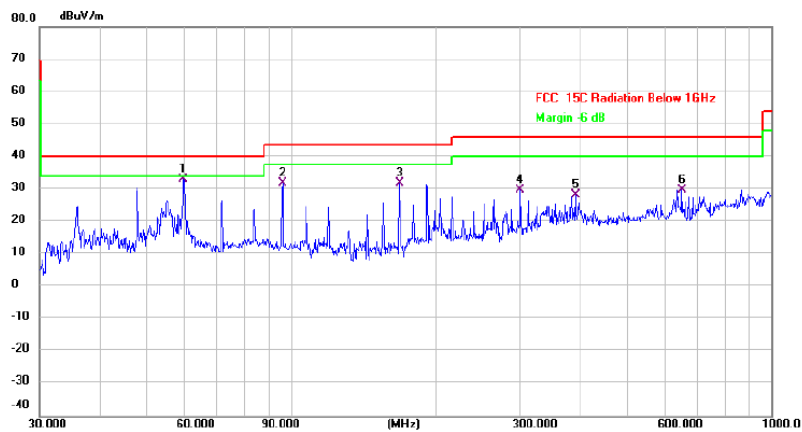

No.	Mk.	Freq.	Reading Level	Correct Factor	Measurement	Limit	Over	Detector	Comment
		MHz	dBuV	dB	dBuV/m	dBuV/m	dB		
1	*	59.8588	42.88	-9.79	33.09	40.00	-6.91	QP	
2		96.0986	42.29	-10.55	31.74	43.50	-11.76	QP	
3		167.8243	42.81	-11.01	31.80	43.50	-11.70	QP	
4		300.3672	34.63	-4.75	29.88	46.00	-16.12	QP	
5		390.7226	32.94	-4.71	28.23	46.00	-17.77	QP	
6		649.6597	31.64	-1.88	29.76	46.00	-16.24	QP	

M220

Mode2 / Polarization: Horizontal / CH: H

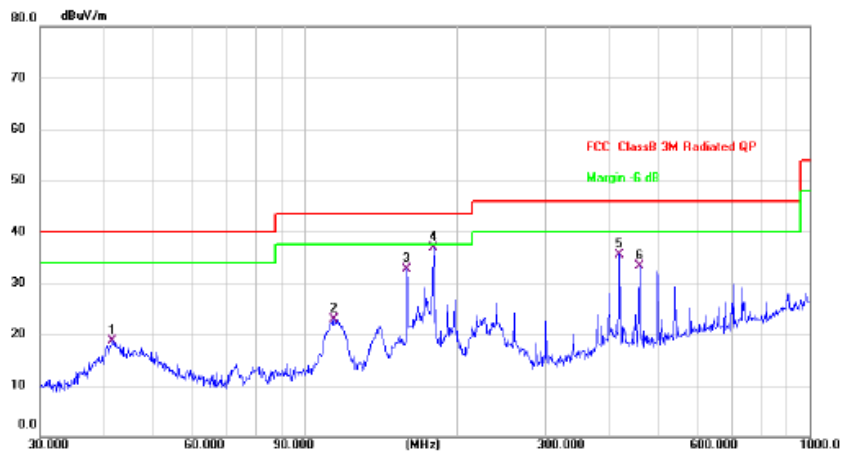

No.	Mk.	Freq.	Reading Level	Correct Factor	Measurement	Limit	Over	Detector	Comment
		MHz	dBuV	dB	dBuV/m	dBuV/m	dB		
1		41.7129	31.67	-12.99	18.68	40.00	-21.32	QP	
2		114.5146	36.97	-14.08	22.89	43.50	-20.61	QP	
3		159.7844	47.85	-15.12	32.73	43.50	-10.77	QP	
4	*	180.0164	51.76	-14.86	36.90	43.50	-6.60	QP	
5		420.5803	44.09	-8.49	35.60	46.00	-10.40	QP	
6		460.7271	40.86	-7.58	33.28	46.00	-12.72	QP	

Mode2 / Polarization: Vertical / CH: H

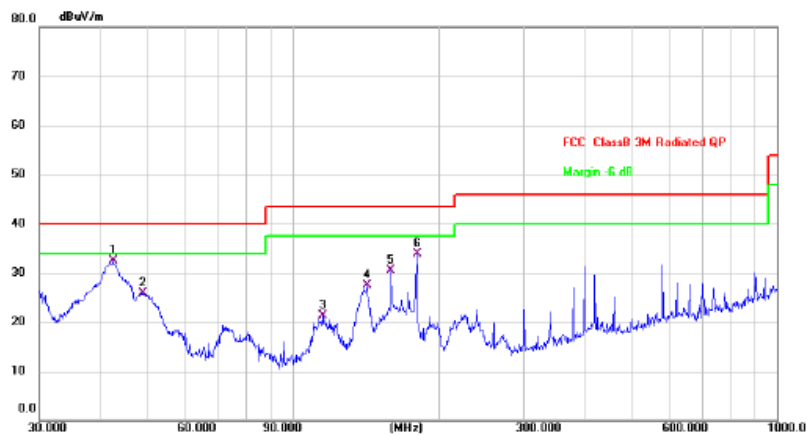

No.	Mk.	Freq.	Reading Level	Correct Factor	Measurement	Limit	Over	Detector	Comment
		MHz	dBuV	dB	dBuV/m	dBuV/m	dB		
1	*	42.6000	45.24	-12.72	32.52	40.00	-7.48	QP	
2		49.1865	38.11	-12.20	25.91	40.00	-14.09	QP	
3		115.3205	35.55	-14.20	21.35	43.50	-22.15	QP	
4		142.3243	41.69	-14.17	27.52	43.50	-15.98	QP	
5		159.7844	45.64	-15.12	30.52	43.50	-12.98	QP	
6		180.0165	48.82	-14.86	33.96	43.50	-9.54	QP	