



ZYXEL
ZoneDAS / SlimDAS
Remote Unit (RU)
Internal Antenna Specification
for
700 to 2700MHz

SUBJECT

- **SPECIFICATION**
 - **SPECIFICATION TABLE**
 - **DAS RU INTERNAL ANTENNA CONFIGURATION**
 - **VSWR**
 - **ANTENNA GAIN AND RADIATION PATTERN**
- 

SPECIFICATION

- Production Name: DAS RU Internal Antennas for
 - 698MHz to 960MHz,
 - 1710MHz to 2170MHz
 - 2300MHz to 2700MHz.
- LTE Operation frequency:
 - Band 1,2,3,4,5,6,7,8,9,
 - Band 10,12,13,14,17,18,19,
 - Band 20,23,25,26,27,28,
 - Band 33,34,35,36,37,38,39,
 - Band 40,41,44
- Feature:
 - 2-in-1 Metal Antenna with 1.37mm cable with IPEX connector
 - Combo with both Directional and Omni Antennas
 - Dimension: 80(L)*80(W)*20(H)mm

SPECIFICATION TABLE

Performance Specifications for 700-960MHz	
Parameter	Omni Antenna
Frequency Range	700-960MHz
Gain	Listed below
VSWR	4.0 Max@700-960MHz
Impedance	50Ω
Efficiency	≥ 30%@ 698MHz
	≥ 30%@ 704MHz
	≥ 45%@ 746MHz
	≥ 50%@ 760MHz
	≥ 50%@ 787MHz
	≥ 60%@ 824MHz
	≥ 60%@ 836MHz
	≥ 60%@ 849MHz
	≥ 50%@ 869MHz
	≥ 50%@ 880MHz
	≥ 50%@ 894MHz
	≥ 45%@ 915MHz
	≥ 45%@ 925MHz
	≥ 45%@ 940MHz
≥ 45%@ 960MHz	

Performance Specifications for 1710-2170MHz-1 Antennas		
Parameter	Directional Antenna	Omni Antenna
Frequency Range	1710-2170MHz	1710-2170MHz
Gain	Listed below	Listed below
VSWR	5.0 Max@1710-2170MHz	3.0 Max@1710-2170MHz
Impedance	50Ω	50Ω
Efficiency	≥ 60%@ 1710MHz	≥ 40%@ 1710MHz
	≥ 61%@ 1750MHz	≥ 40%@ 1750MHz
	≥ 60%@ 1785MHz	≥ 40%@ 1785MHz
	≥ 50%@ 1805MHz	≥ 40%@ 1805MHz
	≥ 50%@ 1840MHz	≥ 35%@ 1840MHz
	≥ 50%@ 1850MHz	≥ 30%@ 1850MHz
	≥ 50%@ 1880MHz	≥ 30%@ 1880MHz
	≥ 60%@ 1910MHz	≥ 35%@ 1910MHz
	≥ 60%@ 1920MHz	≥ 35%@ 1920MHz
	≥ 60%@ 1950MHz	≥ 40%@ 1950MHz
	≥ 60%@ 1960MHz	≥ 40%@ 1960MHz
	≥ 60%@ 1980MHz	≥ 40%@ 1980MHz
	≥ 60%@ 1990MHz	≥ 40%@ 1990MHz
	≥ 50%@ 2110MHz	≥ 45%@ 2110MHz
	≥ 50%@ 2140MHz	≥ 50%@ 2140MHz
	≥ 50%@ 2170MHz	≥ 50%@ 2170MHz

SPECIFICATION TABLE

Performance Specifications for 2300-2700MHz Antennas		
Parameter	Directional Antenna	Omni Antenna
Frequency Range	2300-2700MHz	2300-2700MHz
Gain	Listed below	Listed below
VSWR	2.5 Max@2300-2700MHz	2.5 Max@2300-2700MHz
Impedance	50Ω	50Ω
Efficiency	≥ 40%@ 2300MHz	≥ 45%@ 2300MHz
	≥ 50%@ 2400MHz	≥ 45%@ 2400MHz
	≥ 50%@ 2500MHz	≥ 40%@ 2500MHz
	≥ 35%@ 2570MHz	≥ 45%@ 2570MHz
	≥ 45%@ 2600MHz	≥ 45%@ 2600MHz
	≥ 45%@ 2620MHz	≥ 45%@ 2620MHz
	≥ 50%@ 2690MHz	≥ 45%@ 2690MHz

DAS RU Internal ANT Configuration

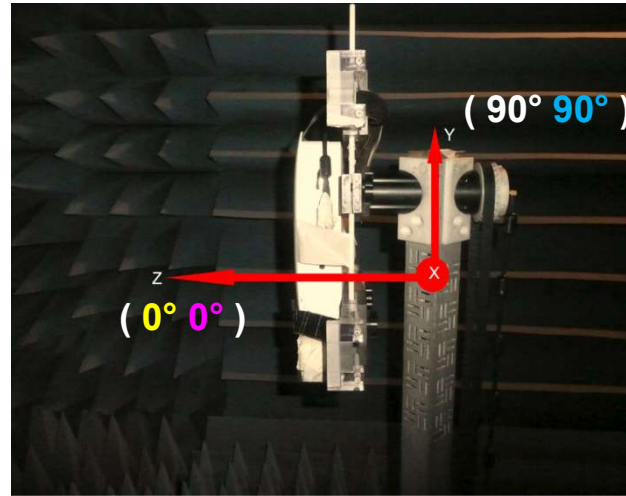
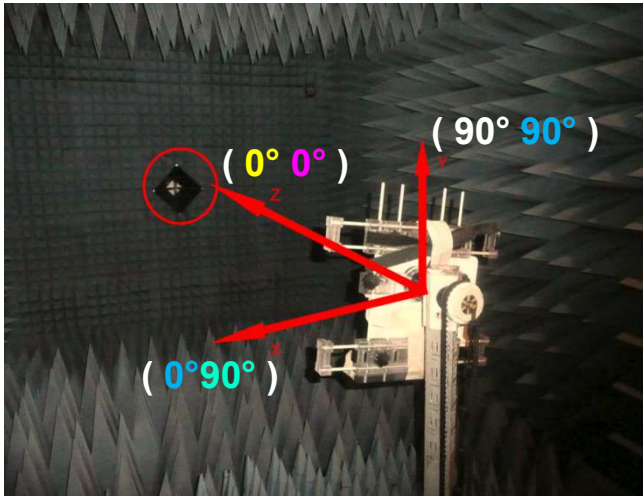

Directional ANT

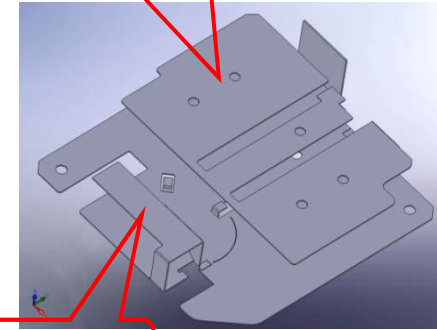

Omni ANT

1710-2170MHz

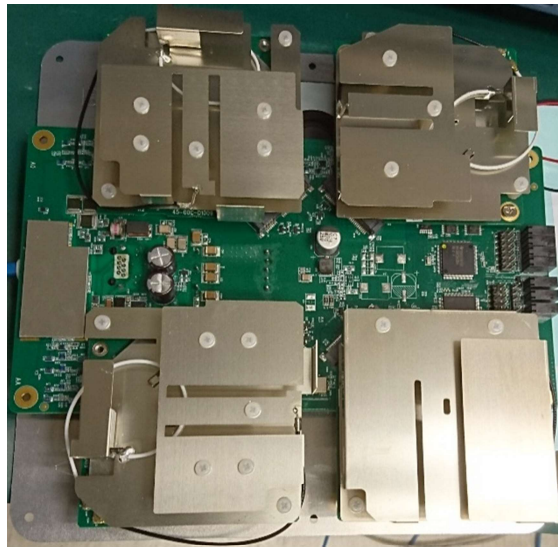

2300-2700MHz



1710-2170MHz-1



700-960MHz



VSWR

700 – 960MHz

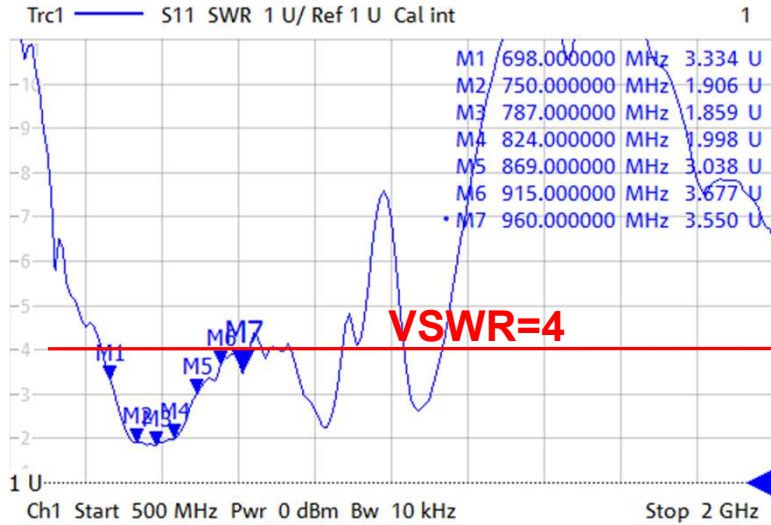

VSWR	
Frequency	698-960MHz
698	3.3
746	2
787	1.8
824	1.9
869	3
915	3.6
960	3.5

VSWR		
Frequency	1710-2170MHz	
	Directional	OMNI
1710	2.2	1.7
1805	1.3	1.4
1920	1.5	2.1
1960	1.6	1.9
2170	1.7	1.4

1710 – 2170MHz

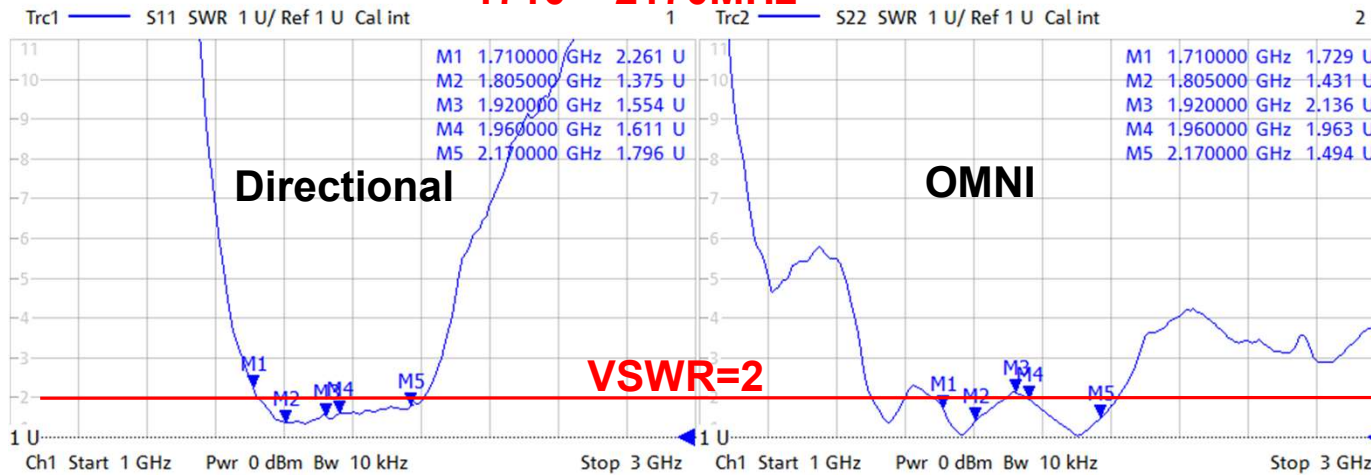

VSWR

1710 – 2170MHz-1



VSWR		
Frequency	1710-2170MHz	
	Directional	OMNI
1710	1.9	1.5
1805	1.4	1.6
1920	1.7	1.3
1960	1.8	1.4
2170	1.8	2.2

2300 – 2700MHz

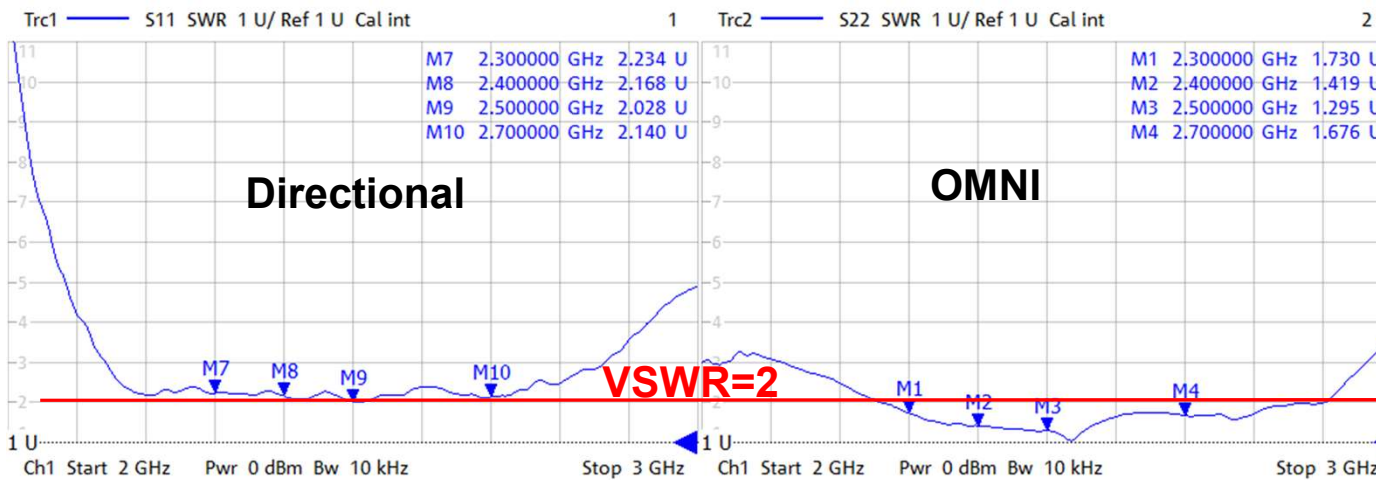

VSWR		
Frequency	2300-2700MHz	
	Directional	OMNI
2300	2.2	1.7
2400	2.1	1.4
2500	2	1.2
2700	2.1	1.6

ANTENNA GAIN

DAS-RU 700-960MHz									
Frequency	3D			V+H Avg. Gain			V+H Peak Gain		
	Efficiency(%)	Avg. Gain	Peak Gain	XY-plane	YZ-plane	ZX-plane	XY-plane	YZ-plane	ZX-plane
698	33	-4.8	0.3	-4.1	-4.8	-3.9	-0.5	0.5	-1.1
704	32	-4.9	0.2	-4.2	-5.1	-3.9	-0.7	0.3	-1.2
746	48	-3.2	1.1	-2.7	-3.0	-2.8	-0.3	0.8	0.6
760	60	-2.2	2.0	-1.8	-2.1	-1.8	0.6	1.5	1.6
787	58	-2.4	1.4	-1.8	-2.1	-2.0	0.1	0.8	1.3
824	74	-1.3	2.0	-0.6	-1.2	-1.0	0.8	1.3	2.1
836	62	-2.1	1.0	-1.3	-2.0	-1.8	-0.1	0.7	1.3
849	65	-1.9	1.2	-1.0	-1.8	-1.6	0.2	0.7	1.5
869	60	-2.3	0.8	-1.3	-2.2	-2.1	-0.1	0.3	1.1
880	59	-2.3	0.9	-1.2	-2.3	-2.3	0.0	0.1	1.2
894	54	-2.7	0.8	-1.5	-2.8	-2.8	-0.3	-0.6	0.9
915	48	-3.2	0.7	-2.0	-3.5	-3.2	-0.2	-0.5	0.5
925	46	-3.3	0.7	-2.2	-3.7	-3.2	-0.2	-0.3	0.3
940	47	-3.3	0.1	-2.2	-3.7	-3.1	0.2	0.2	-0.6
960	47	-3.3	2.2	-3.6	-2.5	-2.7	0.1	1.1	2.2

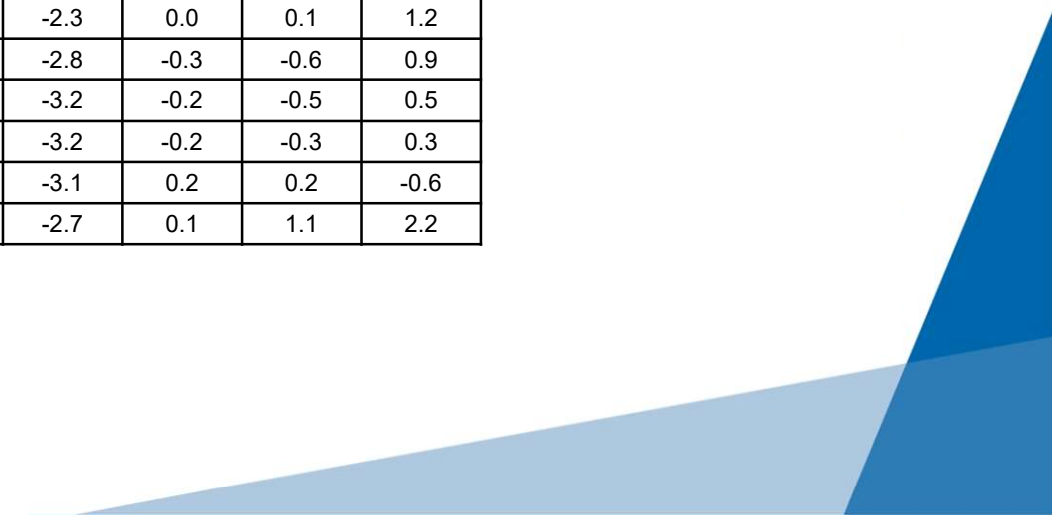
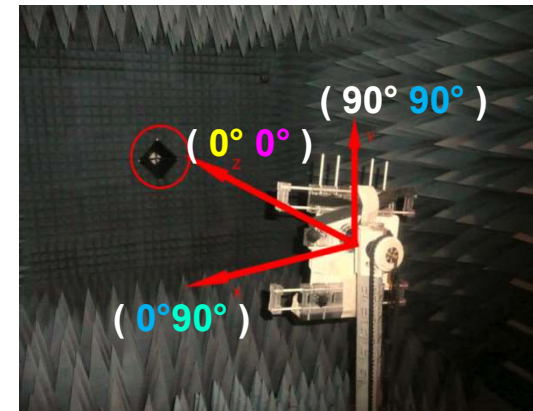

RADIATION PATTERN

2D radiation pattern_700-960MHz

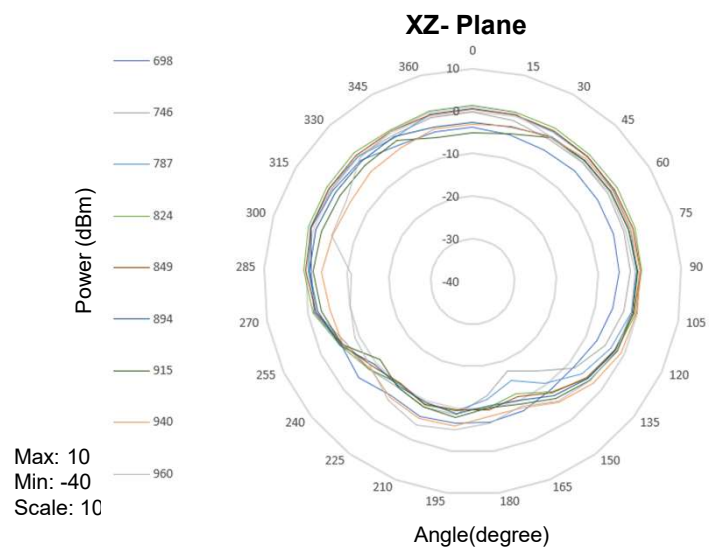
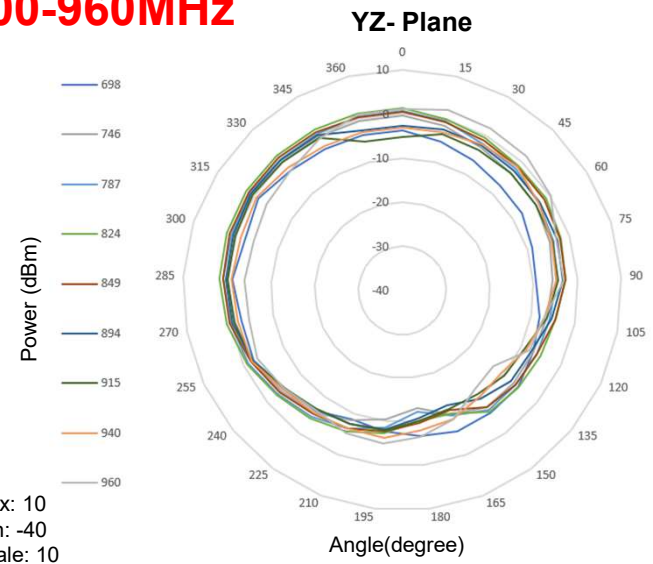
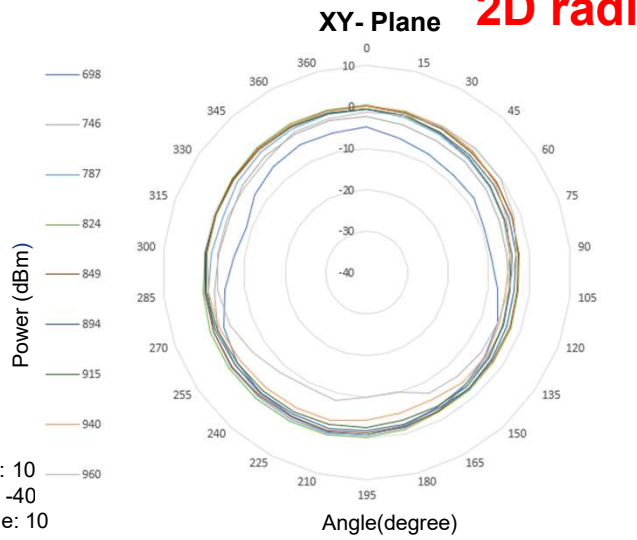

RADIATION PATTERN

3D radiation pattern_700-960MHz

Azimuth = 0.0
Elevation = 0.0
Roll = 0.0

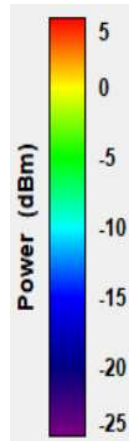
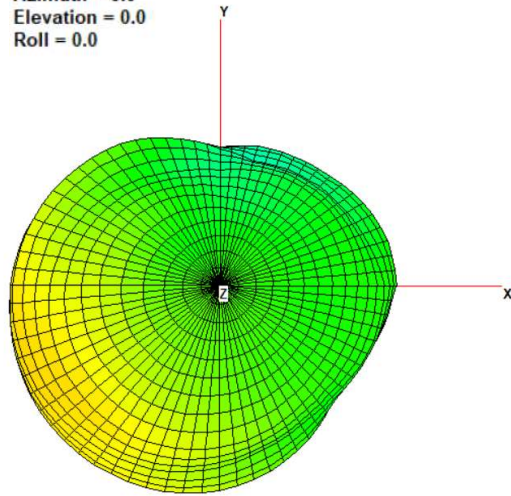

Azimuth = 90.4
Elevation = -0.2
Roll = -74.1

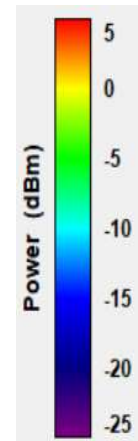
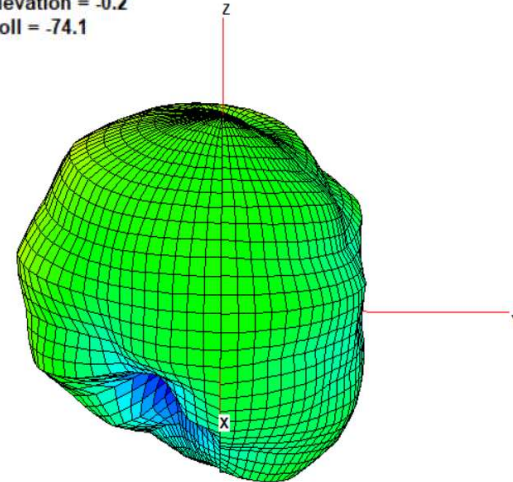

Azimuth = 1.1
Elevation = 54.0
Roll = -0.9

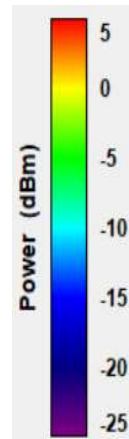
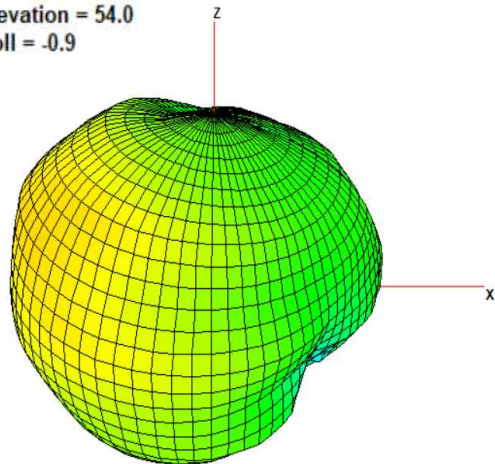

ANTENNA GAIN

DAS RU_1710-2170MHz_Directional antenna									
Frequency	3D			V+H Avg. Gain			V+H Peak Gain		
	Efficiency(%)	Avg. Gain	Peak Gain	XY-plane	YZ-plane	ZX-plane	XY-plane	YZ-plane	ZX-plane
1710	62	-2.1	4.4	-4.4	-1.9	-1.3	-0.7	2.9	3.4
1750	61	-2.1	4.0	-4.7	-1.4	-1.9	-0.7	3.2	2.6
1785	64	-1.9	4.3	-4.6	-0.9	-1.3	-0.9	4.1	3.6
1805	59	-2.3	4.4	-4.8	-1.3	-1.2	-1.7	4.1	3.7
1840	58	-2.4	4.7	-4.7	-1.1	-0.7	-2.2	4.7	4.7
1850	60	-2.2	5.0	-4.7	-1.0	-0.5	-2.2	5.0	5.0
1880	60	-2.2	5.1	-5.4	-1.1	-0.3	-2.2	4.9	4.7
1910	69	-1.6	4.9	-5.0	-0.8	0.1	-0.6	4.8	4.9
1920	73	-1.3	4.8	-4.8	-0.7	0.2	0.1	4.7	4.8
1950	77	-1.2	5.0	-4.5	-0.7	0.1	1.0	4.8	5.0
1960	70	-1.5	4.7	-4.8	-1.1	-0.3	0.6	4.6	4.7
1980	68	-1.7	5.0	-4.9	-1.1	-0.3	0.3	5.0	4.7
1990	65	-1.9	5.0	-5.1	-1.3	-0.3	0.1	5.0	4.6
2110	50	-3.0	4.9	-4.7	-2.5	-0.4	1.3	4.8	4.6
2140	50	-3.0	4.5	-4.6	-3.0	-0.1	2.1	4.2	4.5
2170	56	-2.5	4.7	-3.6	-2.9	0.3	2.8	3.8	4.4

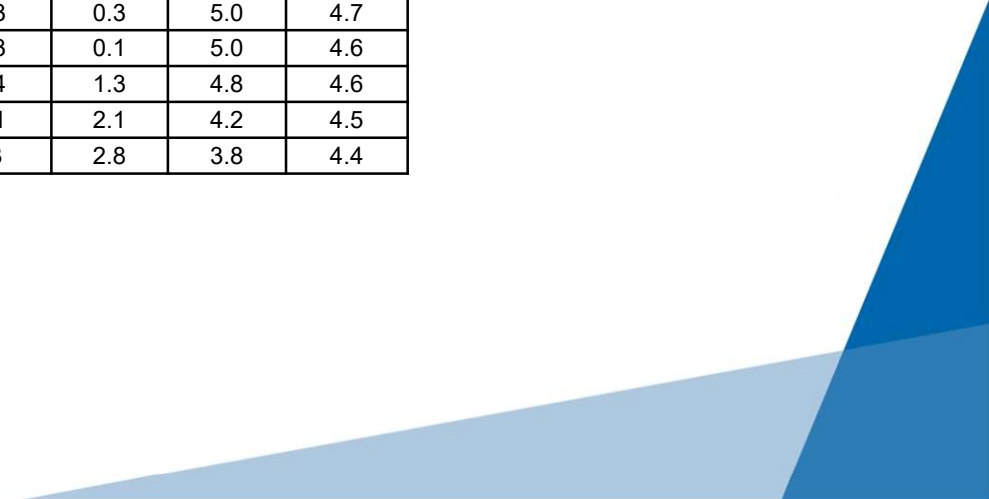
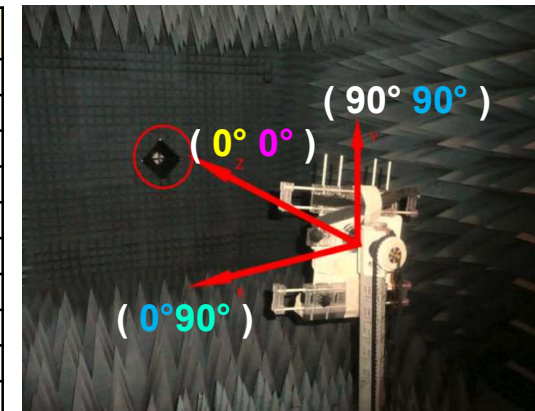

RADIATION PATTERN

2D radiation pattern_1710-2170MHz_Directional antenna

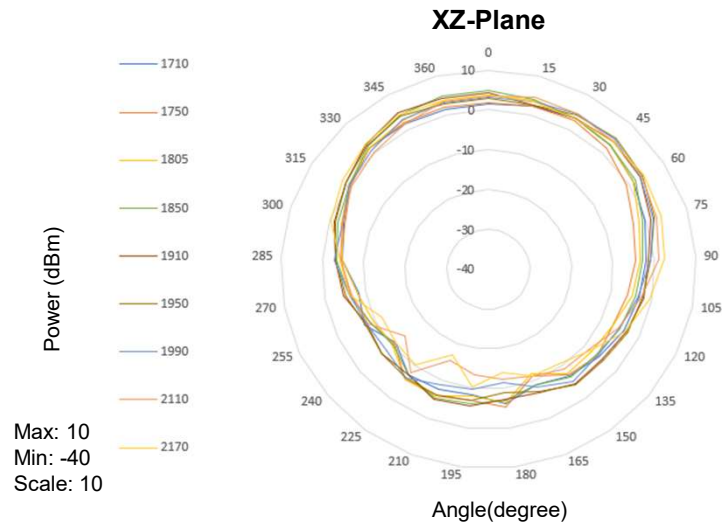
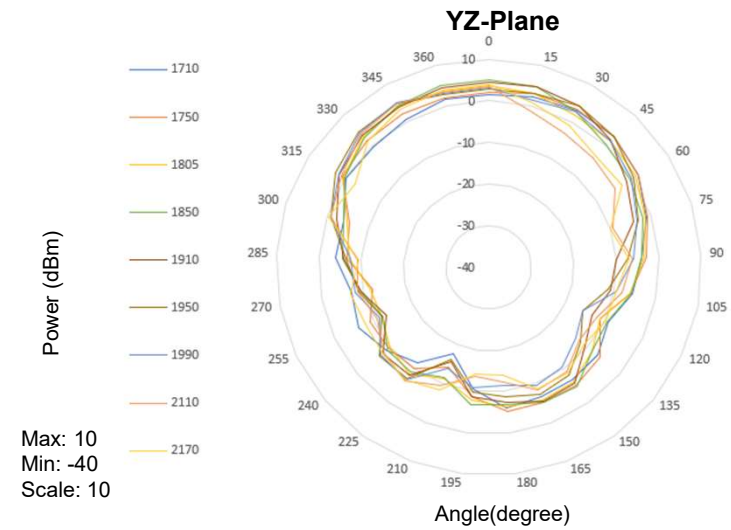
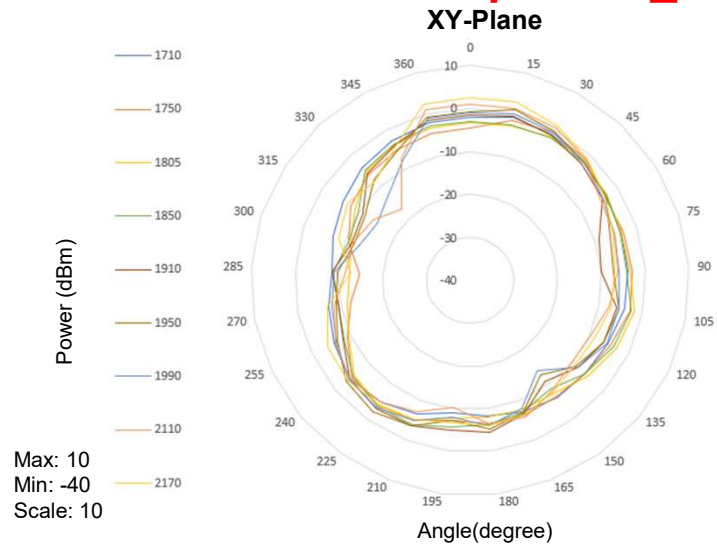

RADIATION PATTERN

3D radiation pattern_1710-2170MHz_Directional antenna

Azimuth = 0.0
Elevation = 0.0
Roll = 0.0

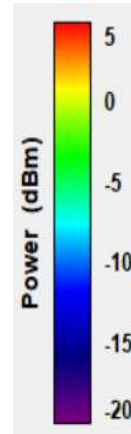
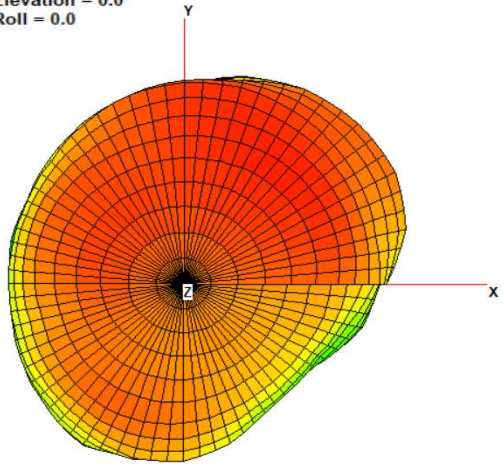

Azimuth = -113.1
Elevation = -41.3
Roll = 56.7

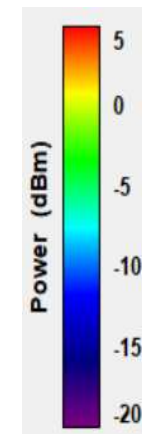
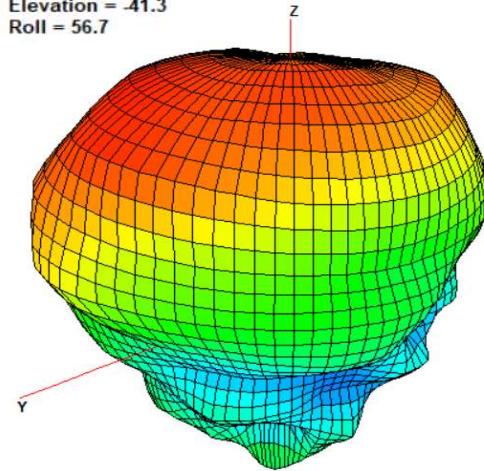

Azimuth = -33.9
Elevation = 70.1
Roll = 31.1

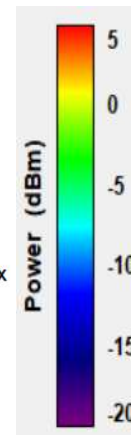
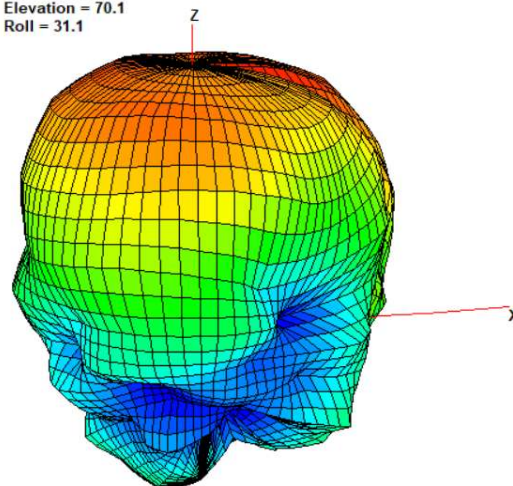

ANTENNA GAIN

DAS RU_1710-2170MHz_OMNI antenna									
Frequency	3D			V+H Avg. Gain			V+H Peak Gain		
	Efficiency(%)	Avg. Gain	Peak Gain	XY-plane	YZ-plane	ZX-plane	XY-plane	YZ-plane	ZX-plane
1710	43	-3.7	2.0	-5.0	-3.0	-3.4	-1.5	0.7	1.5
1750	42	-3.8	2.6	-5.5	-3.5	-3.4	-2.1	1.7	1.2
1785	42	-3.8	3.0	-5.6	-3.4	-2.5	-0.3	1.5	2.7
1805	42	-3.7	3.2	-5.3	-3.4	-1.8	0.7	1.5	3.1
1840	37	-4.4	3.0	-5.4	-4.2	-1.9	0.5	0.8	3.0
1850	34	-4.6	2.6	-5.5	-4.7	-2.3	0.1	-0.1	2.6
1880	33	-4.8	2.8	-5.7	-5.1	-2.8	-0.5	-1.7	2.1
1910	36	-4.4	3.6	-5.5	-4.8	-2.6	-1.6	-0.9	3.1
1920	35	-4.5	3.6	-5.8	-5.0	-2.7	-2.5	-1.1	3.4
1950	42	-3.8	4.0	-4.8	-4.9	-2.3	-1.5	-0.7	3.9
1960	41	-3.9	3.8	-4.7	-5.1	-2.4	-1.5	-0.8	3.6
1980	44	-3.5	3.4	-4.1	-4.9	-2.3	-0.9	-0.7	3.3
1990	41	-3.8	2.8	-4.3	-5.3	-2.7	-1.2	-1.3	2.7
2110	49	-3.1	2.3	-3.0	-3.4	-2.9	0.4	0.5	2.0
2140	50	-3.0	3.0	-3.2	-3.6	-2.8	-0.6	-1.0	3.0
2170	53	-2.8	2.7	-3.1	-2.96	-2.6	0.3	-0.23	2.7

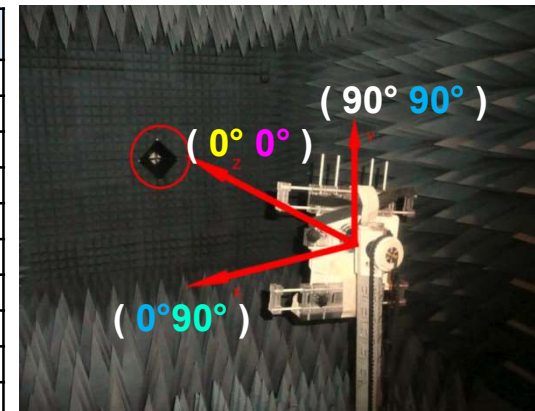

RADIATION PATTERN

2D radiation pattern_1710-2170MHz_OMNI antenna

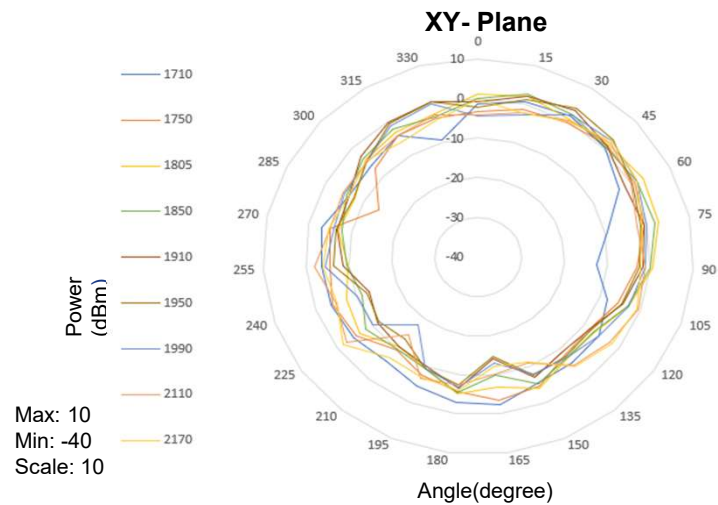
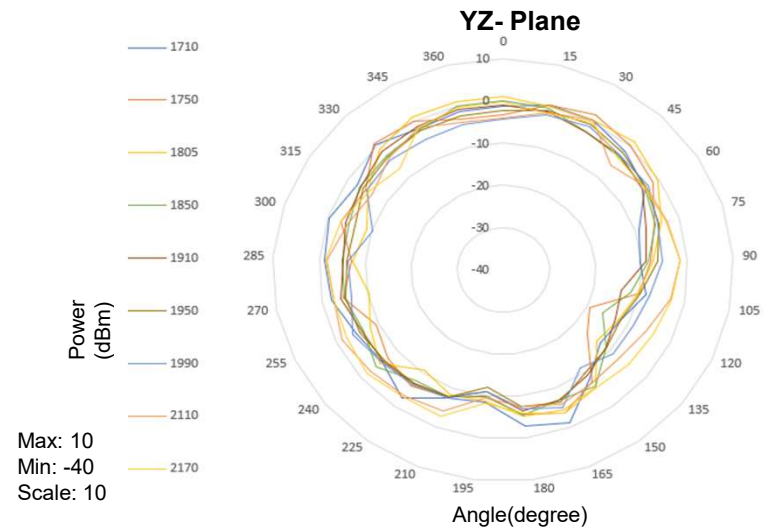
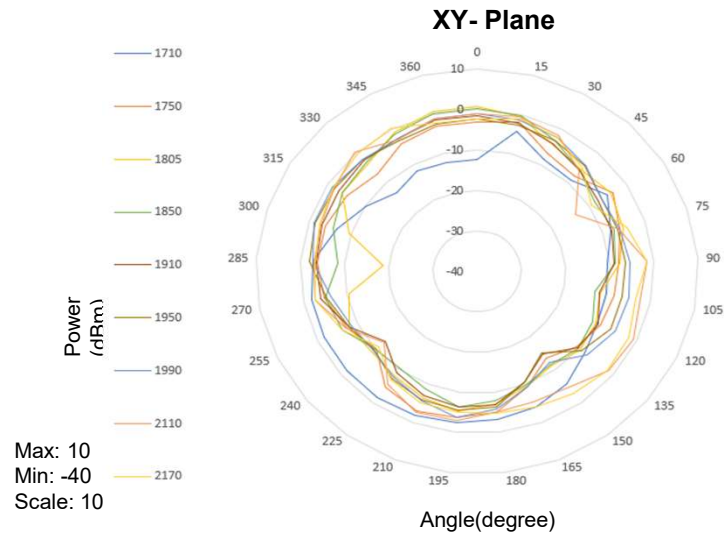

RADIATION PATTERN

3D radiation pattern_1710-2170MHz_OMNI antenna

Azimuth = 0.0
Elevation = 0.0
Roll = 0.0

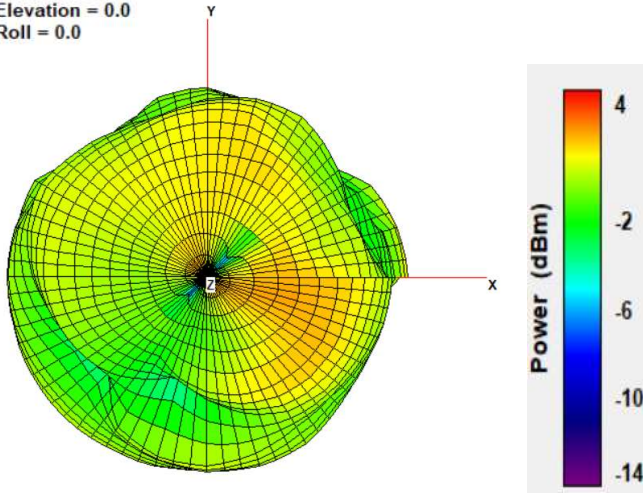

Azimuth = -92.5
Elevation = -27.0
Roll = 85.8

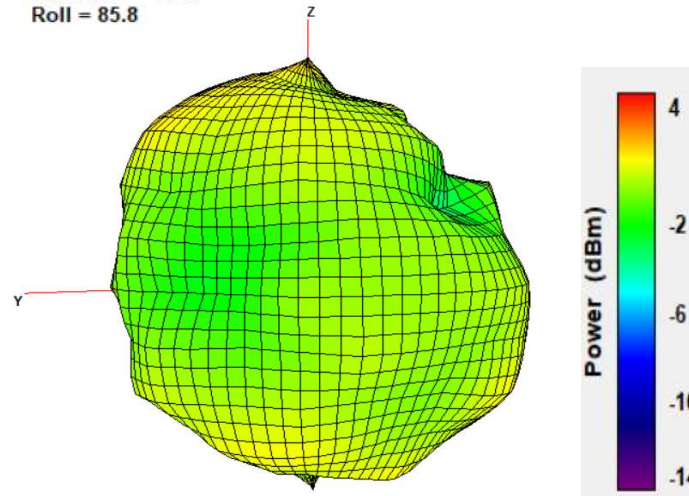

Azimuth = -52.8
Elevation = 83.1
Roll = 53.7

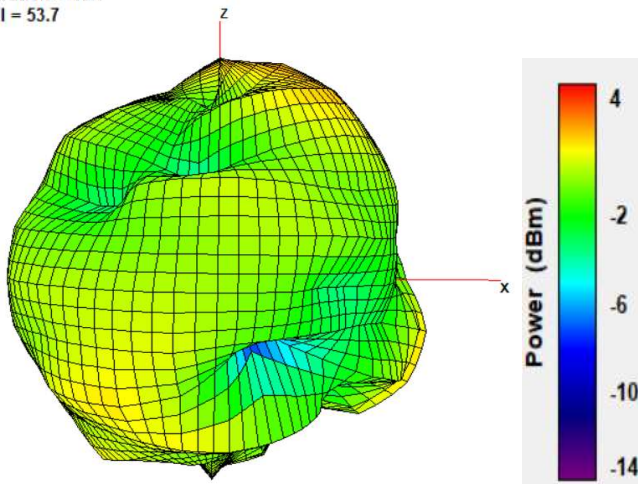

ANTENNA GAIN

2300-2700MHz_Diretcional antenna									
Frequency	3D			V+H Avg. Gain			V+H Peak Gain		
	Efficiency(%)	Avg. Gain	Peak Gain	XY-plane	YZ-plane	ZX-plane	XY-plane	YZ-plane	ZX-plane
2300	44	-3.6	4.9	-7.4	-2.3	-2.8	-3.1	4.5	4.2
2400	58	-2.3	6.2	-5.4	-1.2	-0.6	-2.5	6.2	6.2
2500	52	-2.9	6.0	-5.8	-2.2	-0.7	-1.2	4.4	6.0
2570	35	-4.5	4.7	-8.8	-3.5	-3.0	-5.3	1.3	4.7
2600	47	-3.2	5.7	-7.6	-2.0	-1.7	-3.9	3.4	5.7
2620	46	-3.4	5.3	-7.7	-2.0	-1.9	-3.9	3.7	5.3
2690	50	-3.0	5.0	-7.0	-1.8	-1.8	-2.8	4.9	4.7

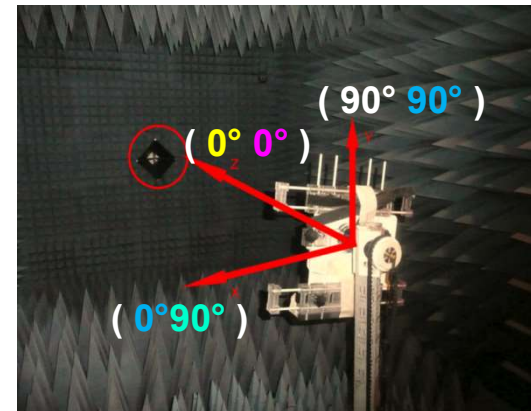

RADIATION PATTERN

2D radiation pattern_2300-2700MHz_Directional antenna

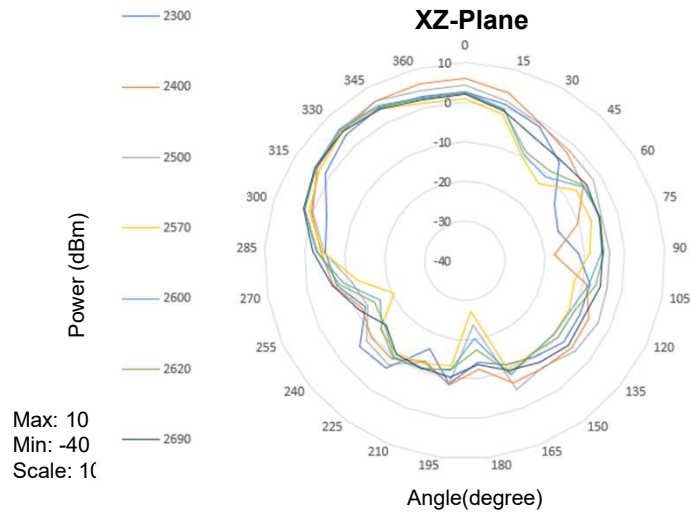
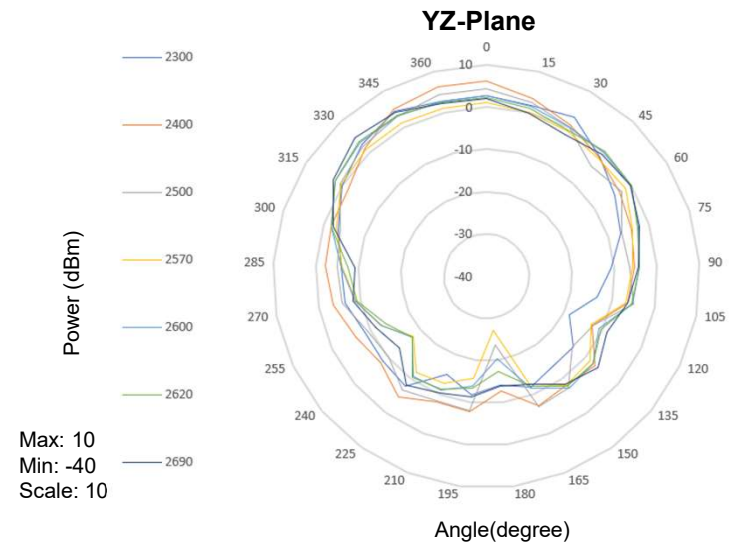
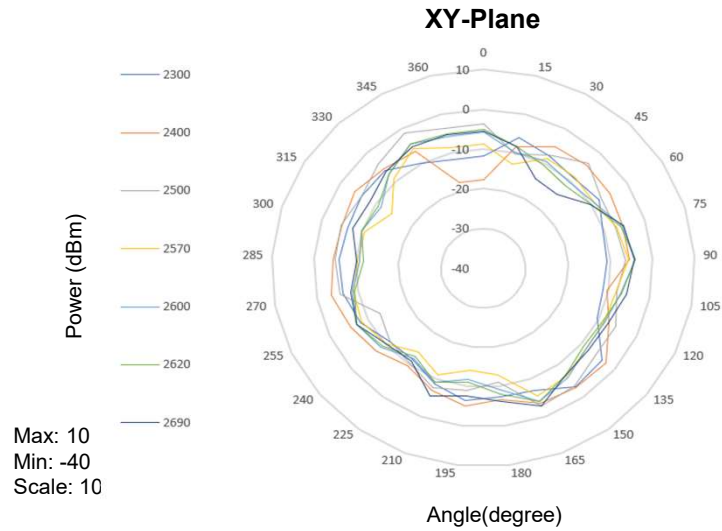

RADIATION PATTERN

3D radiation pattern_2300-2700MHz_Directional antenna

Azimuth = 0.0
Elevation = 0.0
Roll = 0.0

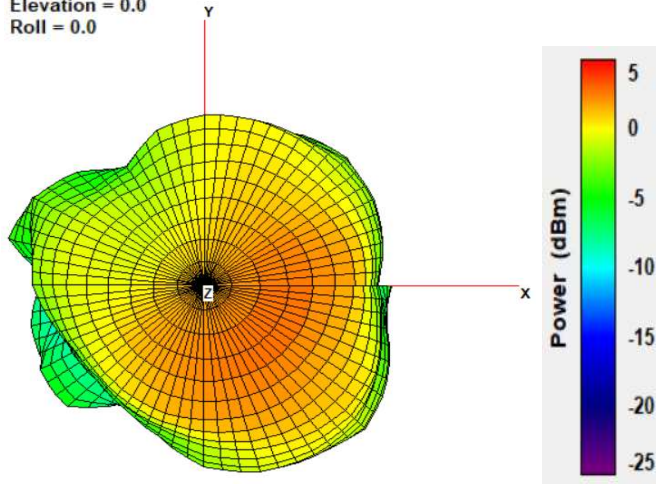

Azimuth = -90.2
Elevation = -6.0
Roll = 77.8

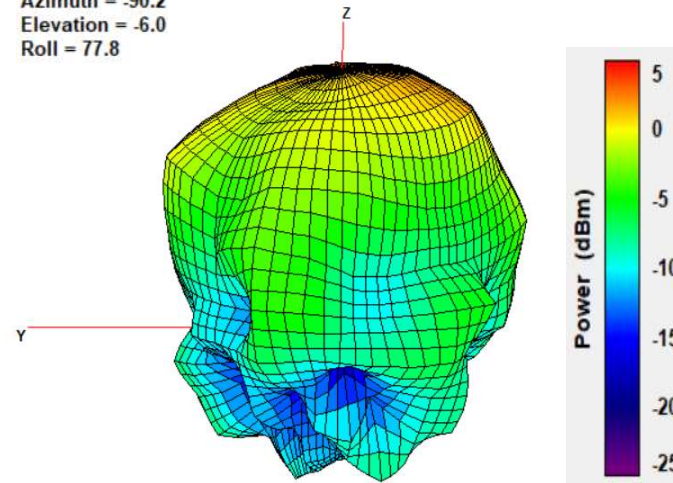

Azimuth = -20.4
Elevation = 70.0
Roll = 20.0

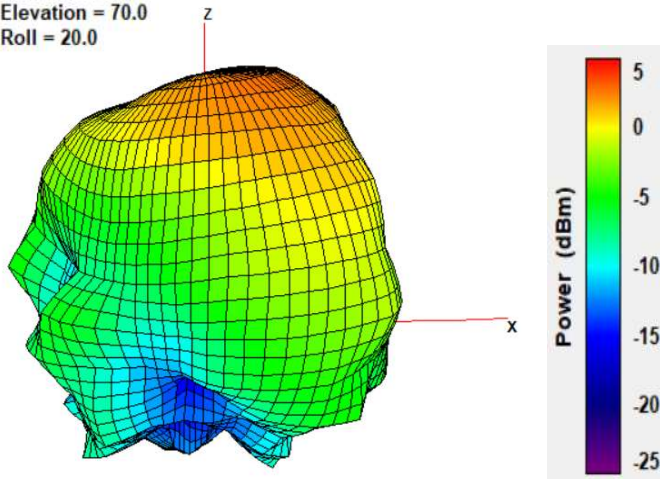

ANTENNA GAIN

2300-2700MHz_ OMNI antenna									
Frequency	3D			V+H Avg. Gain			V+H Peak Gain		
	Efficiency(%)	Avg. Gain	Peak Gain	XY-plane	YZ-plane	ZX-plane	XY-plane	YZ-plane	ZX-plane
2300	45	-3.4	2.2	-4.1	-2.4	-3.5	0.7	0.9	1.9
2400	48	-3.2	3.4	-5.6	-1.6	-3.6	-1.7	3.4	2.4
2500	44	-3.6	3.6	-5.5	-2.5	-3.9	-1.2	3.6	2.4
2570	48	-3.2	2.6	-5.7	-3.4	-3.2	-1.2	2.3	2.2
2600	48	-3.2	2.8	-6.0	-3.4	-3.0	-1.6	2.2	2.3
2620	48	-3.2	2.8	-6.1	-3.4	-3.0	-1.8	2.1	2.4
2690	49	-3.1	2.2	-5.2	-2.9	-2.9	-1.4	1.9	1.9

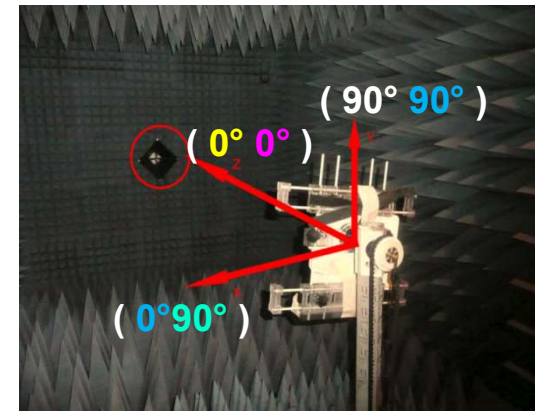

RADIATION PATTERN

2D radiation pattern_2300-2700MHz_OMNI antenna

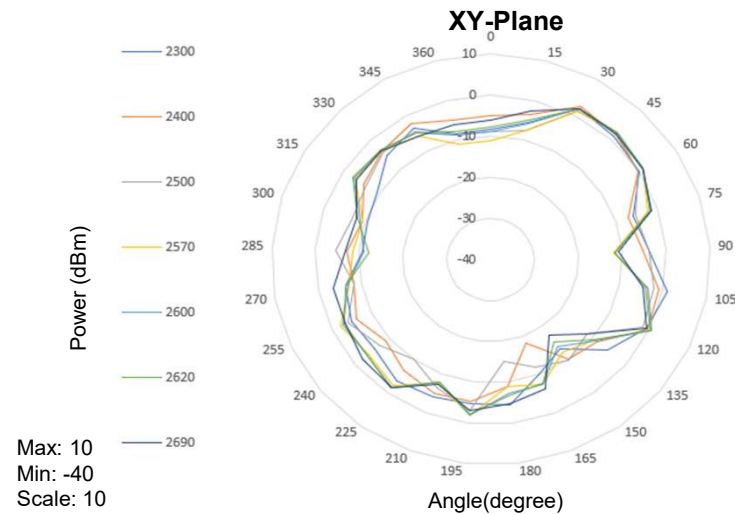
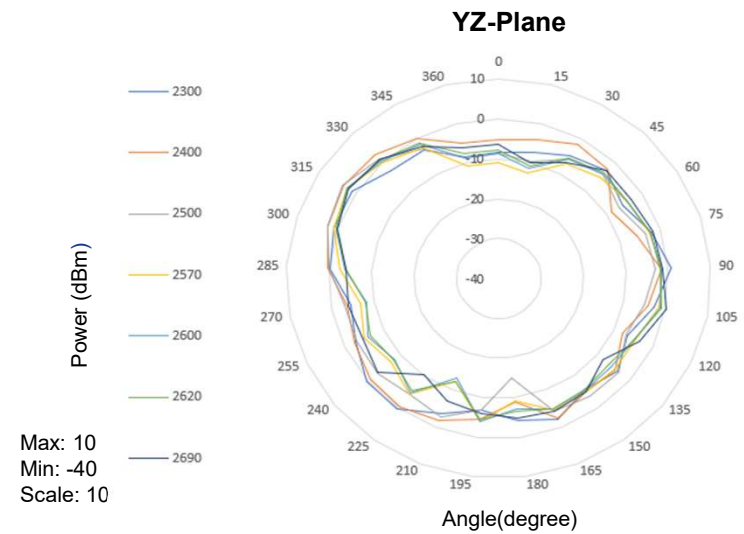
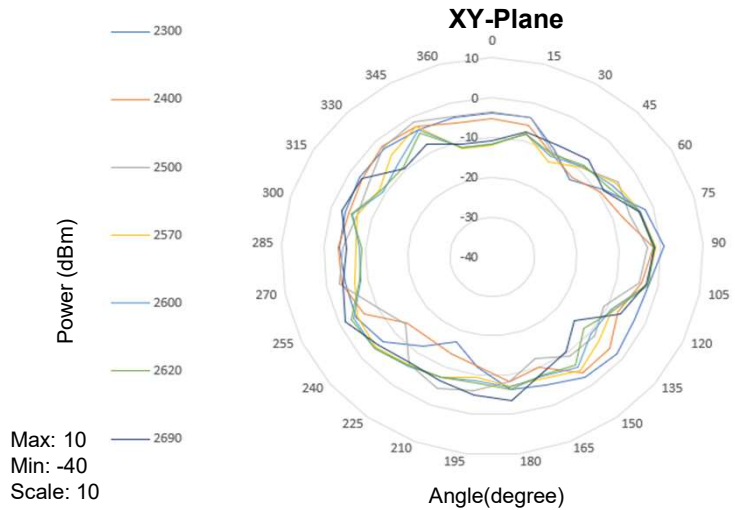

RADIATION PATTERN

3D radiation pattern_2300-2700MHz_OMNI antenna

Azimuth = 0.0
Elevation = 0.0
Roll = 0.0

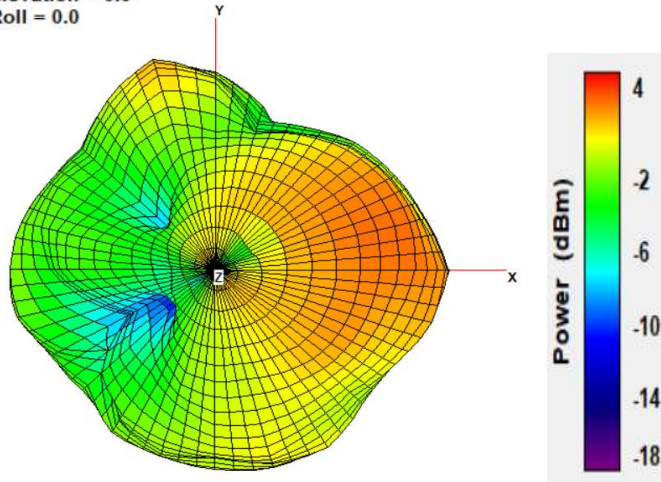

Azimuth = -89.7
Elevation = -7.3
Roll = 85.8

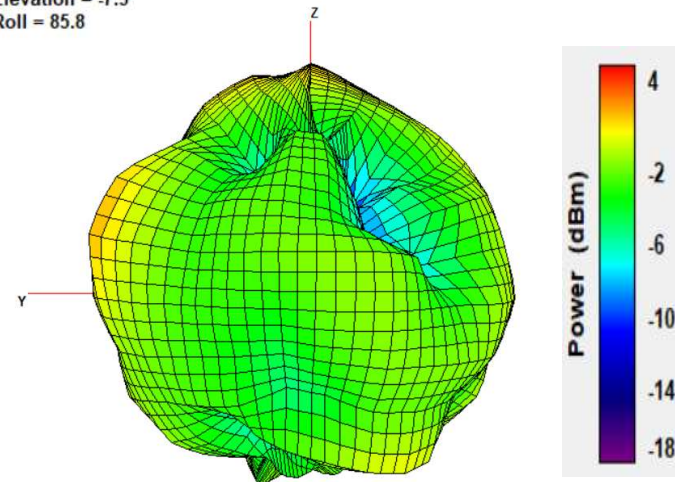

Azimuth = 69.2
Elevation = 81.3
Roll = -68.5

