

Elite Series

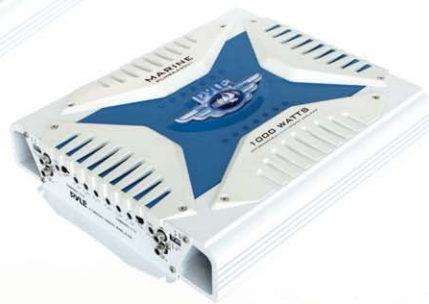

**Built-in
Bluetooth**



Car Amplifier

MODELS:

PLMRA410BT

PLMRA430BT

PLMRA830BT

PLMRA630BT

PLMAR630

PLMRA620



www.pyleUSA.com

Warnings

- Read these instructions and keep them for future reference.
- Carefully follow instructions and follow directions carefully.
- Keep the amplifier dry, as some liquids may contain minerals that corrode electronics circuitry.
- Clean amplifier housing only with a slightly damp cloth. No chemicals or solutions.
- Do not block any of the ventilation openings. Install in accordance with the manufacturer's instructions.
- Do not install near any heat source such as radiators, stoves, or other electrical devices that produce heat.
- Prevent any cables, wired or power cord from being walked on, bent, stretched or pinched, particularly at the plug or at the point where connects to the amplifier.
- When uncertain about specifications, please first consult the Pyle Audio website and see the FAQs.
- Ensure this unit is placed on a stable and flat surface and can accommodate the weight of this unit.
- Unplug this unit during lightning storms or when it is unused for an extended period of time.
- Do not leave this device unattended when powered on.
- Refer all servicing to qualified service personnel. Servicing is required when the device has been damaged or malfunctions in any manner. This would include damage to the power supply cord or plug.

If the unit is likely to undergo excess vibration through use, you must properly install the unit securely. Damage caused by insufficient support is not covered by the warranty. To prevent damage to the unit's panels, always use protective plastic cups or washers before tightening mounting bolts.



Service may be obtained from an authorized Pyle Audio service center. Contact Pyle Audio and make sure you have a receipt as proof of purchase along with the defective unit. You will be then instructed to send or deliver the malfunctioning unit to an authorized center. They will handle the necessary paperwork and repair. Remember to transport your unit in the original factory packaging.

PLEASE NOTE: Users must ensure that any type of smoke and related substances are not allowed to enter the amplifier. Smokey air is corrosive and prolonged exposure will cause irreparable damage to your amplifier. Take precaution before reconnecting to a power supply. Be aware that when any equipment is taken from a cold to humid location, condensation may occur inside. Always allow time for the equipment to attain the same temperature as its environment before reconnecting to a power supply.

Testing & Connections

After all the connections have been made. turn on your stereo and listen for the amplifier to turn on. If there are any unusual noises from the speakers then turn the system off and recheck all the wiring.

After you have connected your radio or equalizer to the amplifier, you may adjust the gain control to match the output level of your radio:

- (A) Set the volume control on your radio to 2/3 position.
- (B) Adjust the gain control for an average listening level.
- (C) Turn the radio volume all the way down and listen for background noise.
- (D) Start your vehicle and listen for electrical noise.
- (E) Making fine adjustments to the sensitivity can reduce background noise and some engine noise.
- (F) CAUTION: Never turn the sensitivity up any farther than you need to get clear sound at 2/ 3 volume.
- (G) This adjustment only needs to be made once.

NOTE: CARE MUST BE TAKEN AGAINST BATTERY OVER-DISCHARGE CAUSED BY LONG OPERATION OF THE SET AT A HIGH SOUND LEVEL WHEN THE ENGINE IS NOT RUNNING OR IDLING.

Maintenance

Keep the amplifier dry. If it gets wet, wipe it dry immediately. liquids can contain minerals that corrode electronic circuits.

Use the amplifier only in normal temperature environments. Temperature extremes of heat or cold can shorten the life of electronic devices and distort or melt plastic parts.

Handle the amplifier gently and carefully. Dropping it can damage circuit boards and cases and can cause the amplifier to work improperly.

Keep the amplifier away from dust and dirt. which can cause premature wear of parts.

Wipe the amplifier with a damp cloth occasionally to keep it looking new. Do not use harsh chemicals, cleaning solvents, or strong detergents to clean the amplifier.

After all the connections have been made. turn on your stereo and listen for the amplifier to turn on. If there are any unusual noises from the speakers then turn the system off and recheck all the wiring.

PLMRA210BT - System Layout

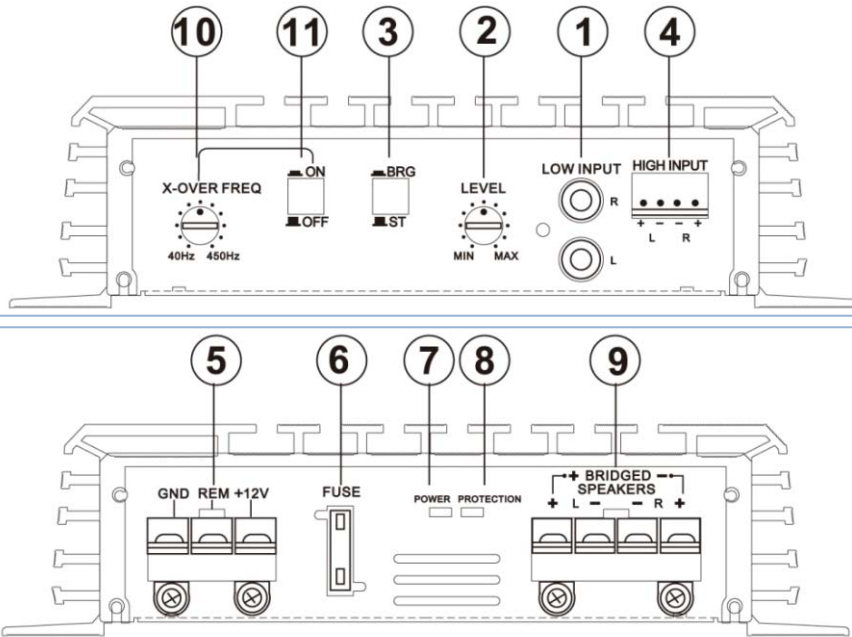

PLMRA210BT

1	RCA (Low Level Input)	This unit is provided with RCA Input jacks. Couple the RCA Input with the car stereo or equalizer outputs using RCA type connector cables.
2	Input Gain Control	These are NOT Your amplifiers volume controls. They are a sophisticated device which is to be utilized when matching the Input signal of your head unit or equalizer to their amplifier.
3	Bridging Capability	Can be bridged to a high power one channel unit. Make sure that you have a speaker or series of speakers on the bridged channel capable of handling at least 200 Watts of RMS power.
4	Speaker Connectors (High Level Input)	This unit is provided with terminal inputs. Couple the terminals with a standard car stereo output system with common ground to floating ground type originally output to speakers. The speaker wires of the car stereo should be connected to "L-" and "R-" terminals respectively. If the car stereo comes out with three wires only, connect the "COMMON" wire to both "L" and "R" input of the amplifier.
5	Power Supply Terminal	Connect the + 12V DC power supply into the terminal by lugs and screws accessible at the panel of this amplifier.

	BATT +12V	Connect+ 12V DC power supply wire into the terminal from the terminal of the fuse at battery. (Fuse preferably installed 1 foot within 1 foot from the battery).
	GROUND	Ground terminal connect the ground wire to the chassis of the automobile, boat or other vehicle.
	REMOTE	Remote terminal connects the control wire which provides remote turn-on and power off.
6	Power on LED	When the amp is properly grounded and has proper power and is receiving its remote power signal the green LED will light up indicating power conditions are correct.
7	Protection LED	This indicator is illuminated when built-in protection circuitry is activated.
8	Power Fuse	Power fuse protects both this amplifier and the automobile electrical system from wrong electrical conditions.
9	Speaker Terminals	The speaker terminals are silver-plated for high conductivity and minimum impedance loss. Be sure to strip just enough insulation off your speaker wires that will fit under the screw plate to help ensure against speaker wire short circuits. The amp can support an impedance load as low as 2 ohms per channel or 4 ohms in the bridged mode, though a 4 ohm stereo load and 8 ohms bridge load will greatly increase the life expectancy of the amplifier.
10	Crossover Frequency Circuit	Lets you adjust the crossover frequency from 40-450 Hz for both channels.
11	Crossover On/Off Switch	Allows for operation to run at full range or with built-in crossover use.

The Pyle Elite Series Amps feature options and configurations that vary among the various models in the amplifier line availability. Refer to the specific model number for detailed amplifier connection options and features. Visit us online for detailed specifications and more information.



www.pyleUSA.com



Stereo Input Connection

RCA Type Terminals
High Impedance
Low Level Inputs

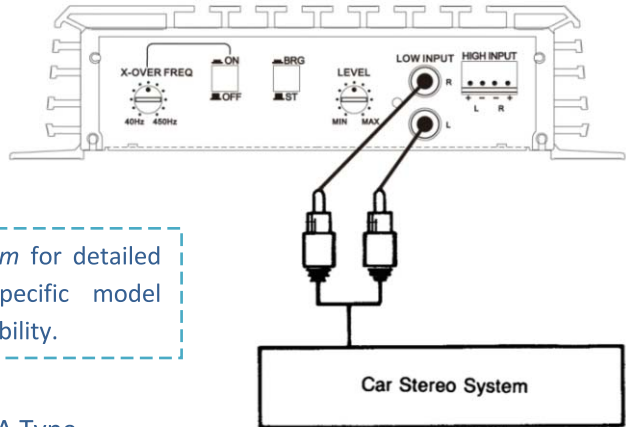

Stereo Input Connection - RCA Type

The Elite Series Amps feature plated RCA terminals for low level input connections to match radios and equalizers with line level output. Couple the RCA input with the car stereo/equalizer output using RCA type connector cables.

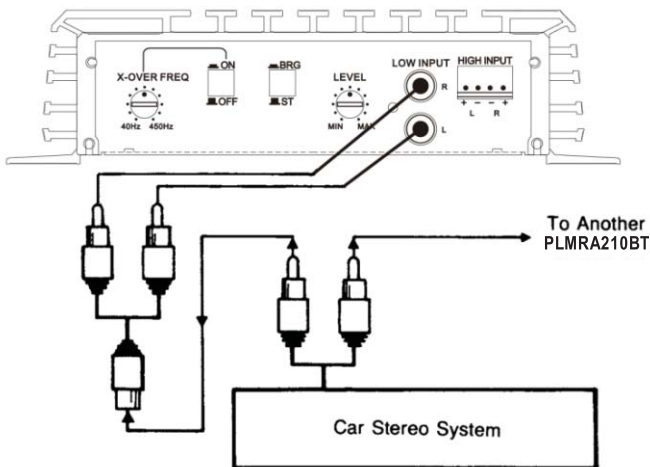

Mono Input Connection

RCA Type Terminals
Bridge-Ability

*Not available on all
PLMRA amp models.



Mono Input Connection - RCA Type

Select Elite Series Amps may easily be bridged for mono operation by feeding the same signal to both LEF T and RIGHT Input terminals. The simplest way to achieve this is by using a Y-adaptor to connecting your car stereo output.

Speaker Connection - Stereo Amp System

Connect the output terminals to the corresponding LEFT and RIGHT Speakers. (Fig. 1 below shows a pair of speakers connected in stereo)

Speaker Connection - Mono Amp System

Select Elite Series Amps may be bridgeable from a 2 channel amplifier to a one channel amplifier. The ideal speaker impedance for optimum operation is 4 ohms. The amplifier will provide stable operation when operated between 2 and 8 ohms loads. The minimum recommended speaker load is 2 ohms for each channel in normal operation. When operating in the bridged mode the minimum recommended speaker load is 4 ohms for each bridged channel. Operation of the amplifier below this impedance load can damage both the amplifier and your speaker and will void your warranty.

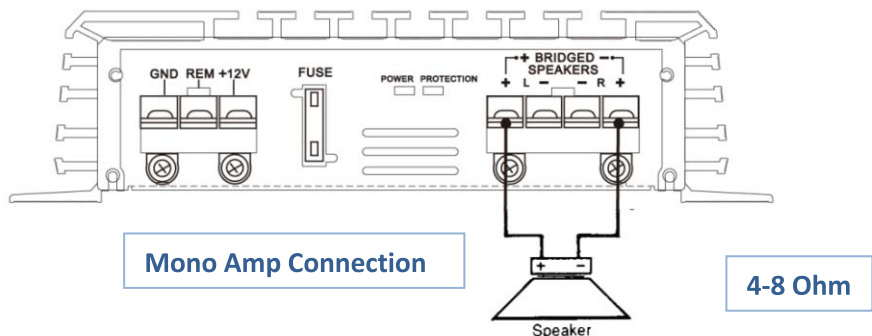
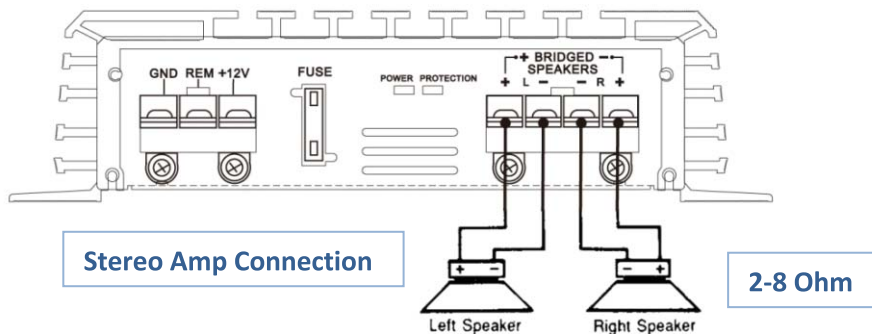

Speaker negative terminals on the amplifier are not used in the bridged mode. Bridging is done by using multiple channels of an amplifier to drive a common load. Bridging means that you will use more than one source of power to drive a load (speaker). The sources of power are the independent channels of the amplifier.

Some users may automatically set the gain to maximum because they want their music loud, by doing so, they are also increasing the chance of burning out their amplifiers. Please follow the instructions found in this manual to help match the signals correctly. Your system can also become extremely sensitive to noise conditions when you have a high signal level coming into the amplifier, from your connected source, which should be adjusted accordingly. Avoid problems and match your system levels correctly!

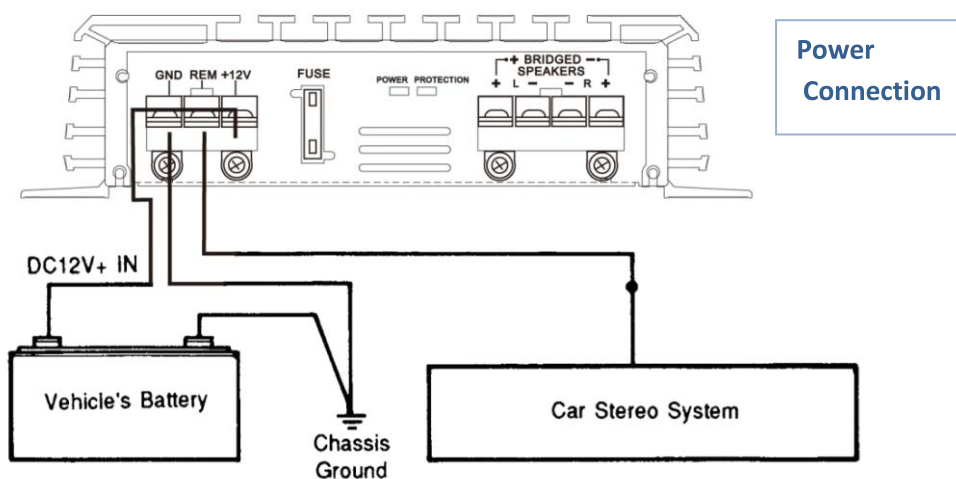

Power Connection

Connect the +12V of the amp to your vehicle's battery (+)

Connect the GND of the amp to your vehicle's battery (-), ground properly

Users may also reinforce the ground connection by adding another connection of gauged wire from the (-) negative battery terminal to the chassis of the stereo unit.

Connect the 'Remote' of the amp to your vehicle's external switch for a positive 12V ON/OFF connection. This may be connected to the receiver power antenna lead (Amp turn on) -- typically blue in color.

Visit www.PyleAudio.com for detailed model information and connection ability.
Models: PLMRA210BT, PLMRA410BT, PLMRA430BT, PLMRA630BT, PLMRA830BT

PLMRA210BT - Wiring

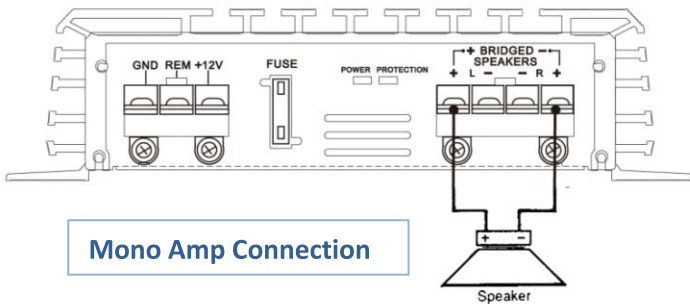
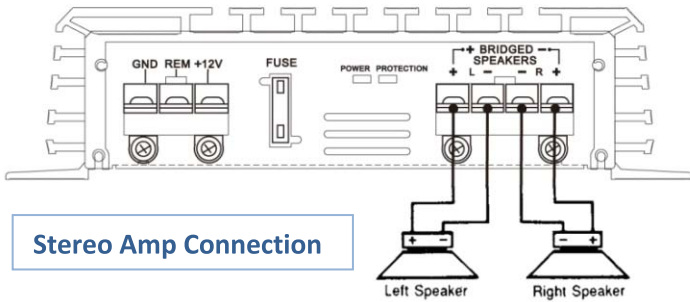

PLMRA410BT - Wiring

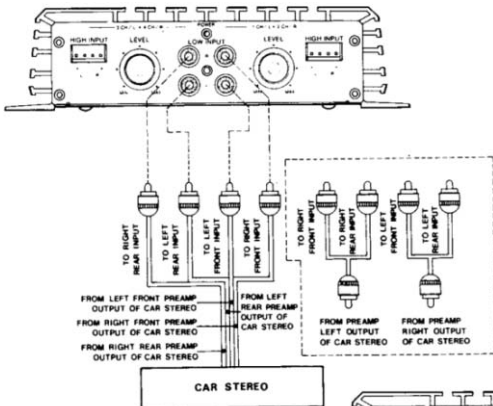

Stereo Input Connection
RCA Input

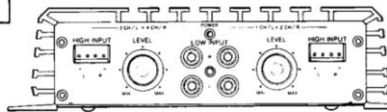

High Level - Speaker Level (BTL or Common Ground)
Four Speaker Output Mode
Floating Ground Type

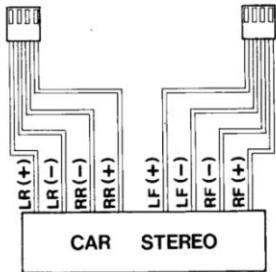

PLMRA410BT - Wiring

Common Ground Type

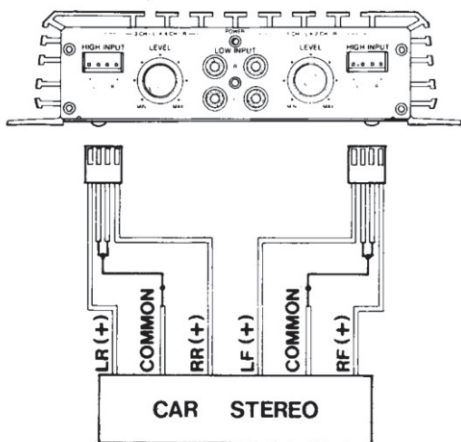

Two Speaker Output Mode
Floating Ground Type

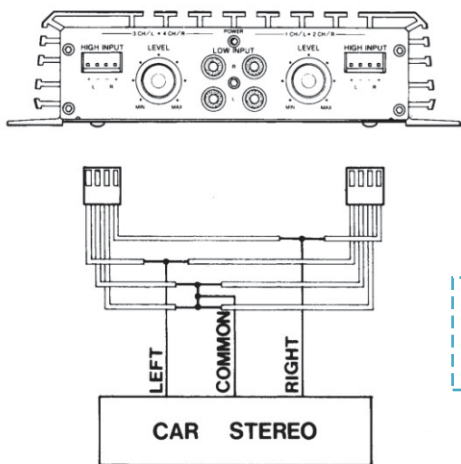
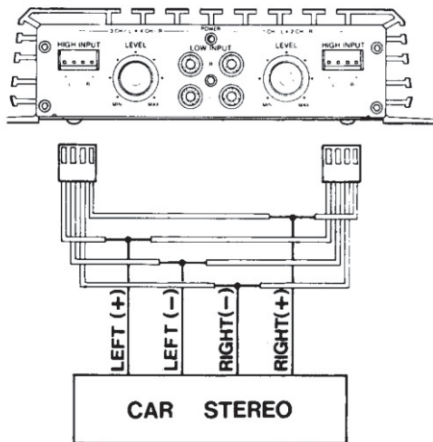

*High and Low impedance inputs cannot be used at the same time.

Note:

Elite Series Ampshave built-in short circuit protection. If you mistakenly connect any speaker wires to ground, or positive power (+) and (-) Wires short together, the protection circuit will operate automatically and cut-off output. In case of this, you must switch OFF the whole system immediately double check speaker wire connections and isolation before switching on the amplifier again.



PLMRA410BT - Wiring

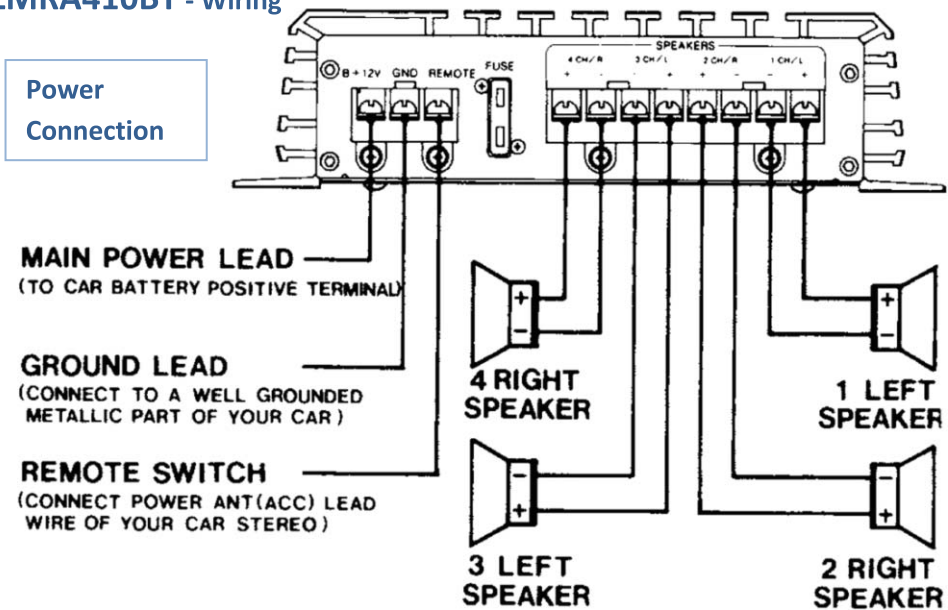

Connect the speaker output terminals to the corresponding speakers. The speakers must be high quality and capable of handling high power. Separated return paths and strong wires are required.

1. Connect the B+12V pole of power supply directly to the battery(+) position terminal (In-line fuse 1 foot from battery).
2. Connect the GND pole of power supply directly to the (-) negative ground battery terminal or vehicle chassis.
3. To make a good grounding and prevent motor boating noise problem connect another 12 gauge minimum wire from the (-) negative battery terminal to chassis of stereo unit.
4. Connect the 'Remote' pole to external switch for positive 12V ON/OFF. This may be connected to the receiver power antenna lead.

PLMRA430BT - Wiring

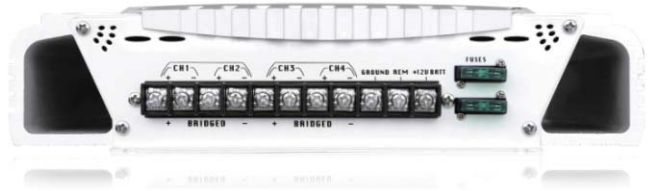
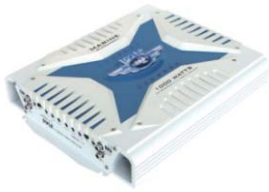

Power Connection

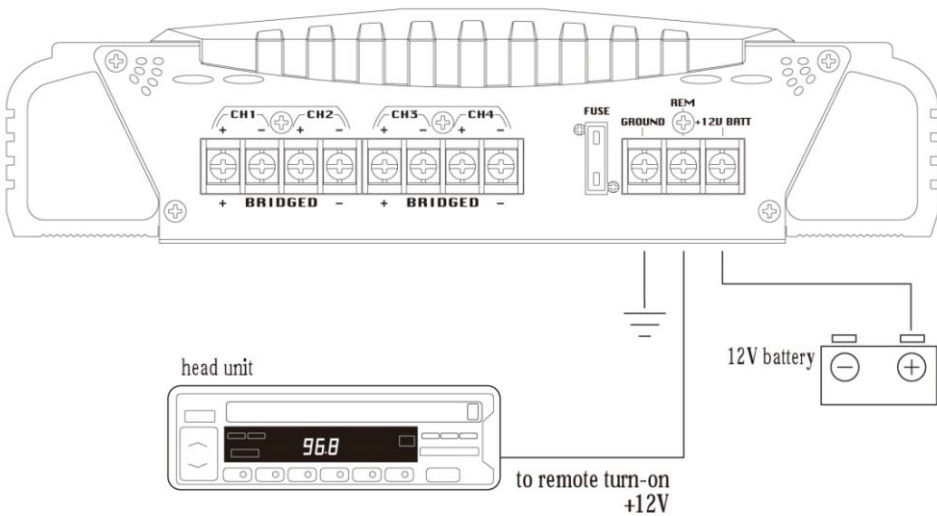

PLMRA430BT - Wiring

4 Channel Input Connection
Low Level Inputs

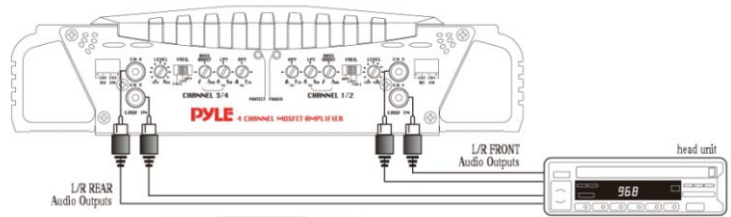

2 Channel Input Connection
Low Level Inputs

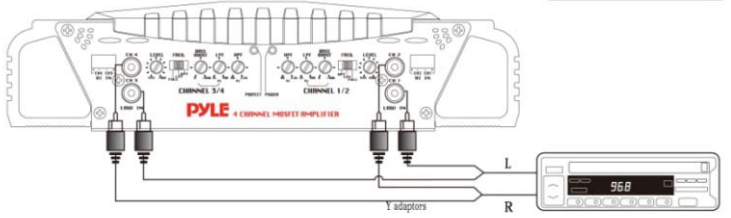

High Level Wiring

4 Channel Connection
Floating Ground

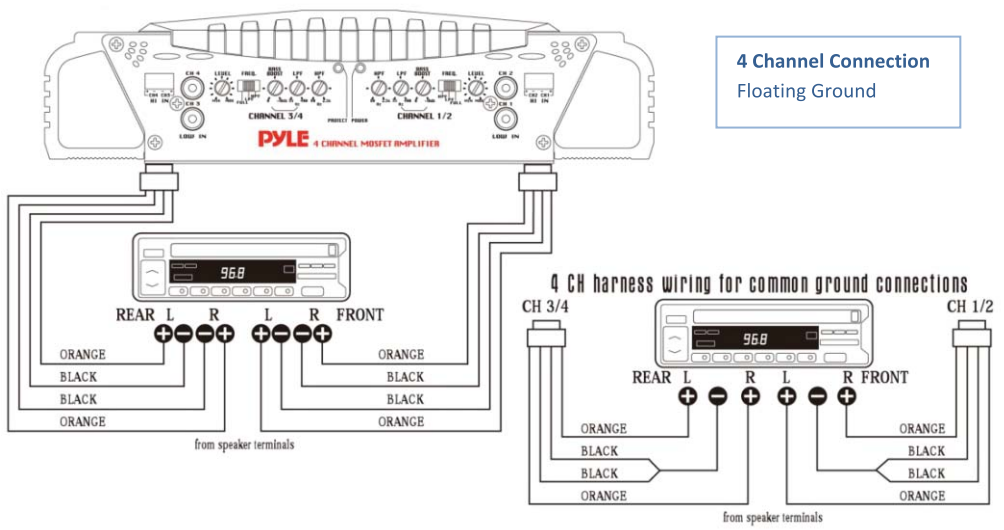

Visit www.PyleAudio.com for detailed model information, specific model wiring and connection ability.



PLMRA430BT - Wiring

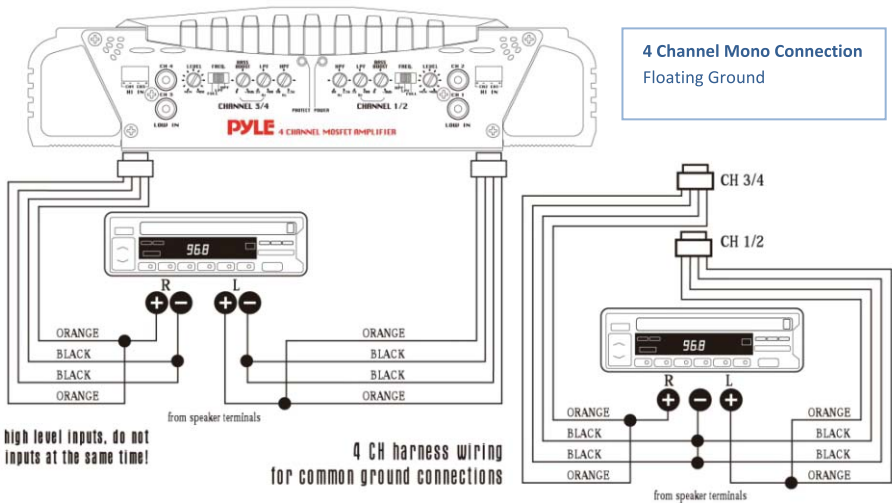
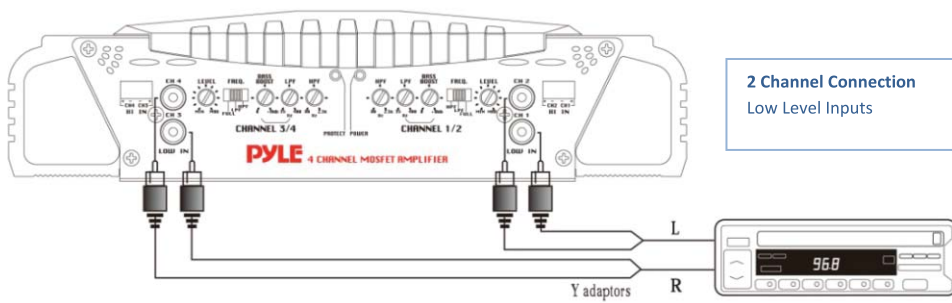
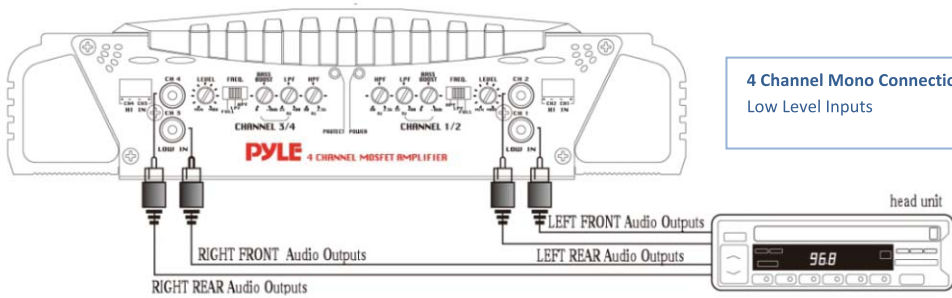

PLEASE NOTE! If using high level inputs, do not use the low level RCA inputs at the same time!

PLMRA430BT - Wiring

4 Channel Output Mode

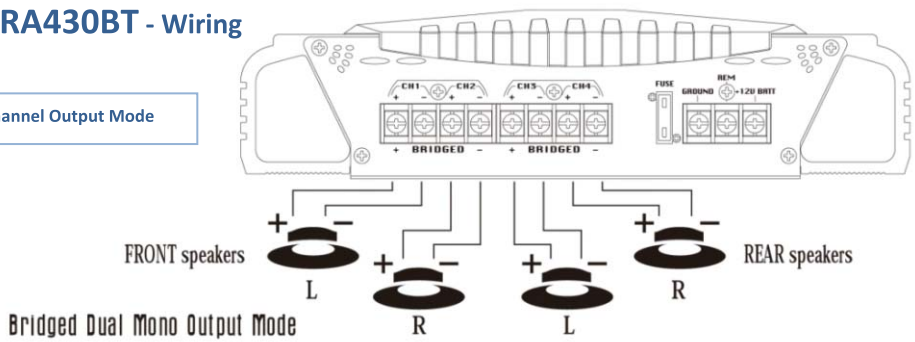

Bridged Dual Mono Output

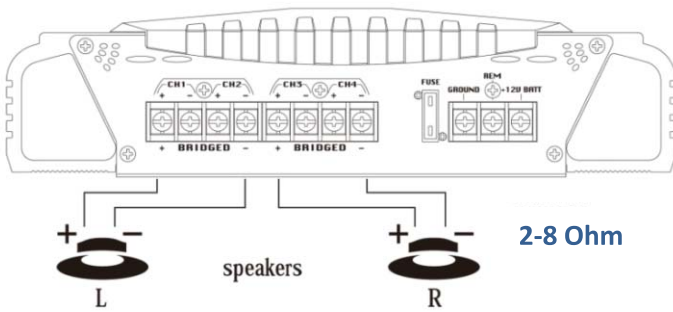

4 Channel Stereo Output Mode with Mono Bridged Subwoofer Output

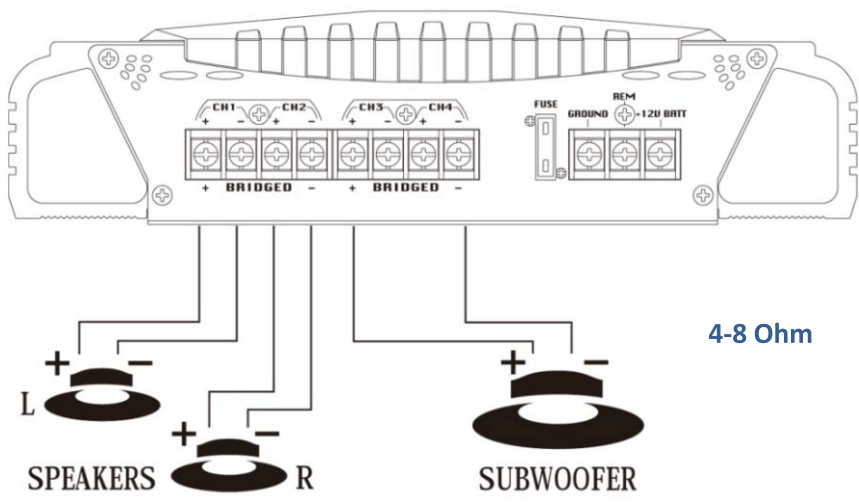

PLMRA630BT - Wiring

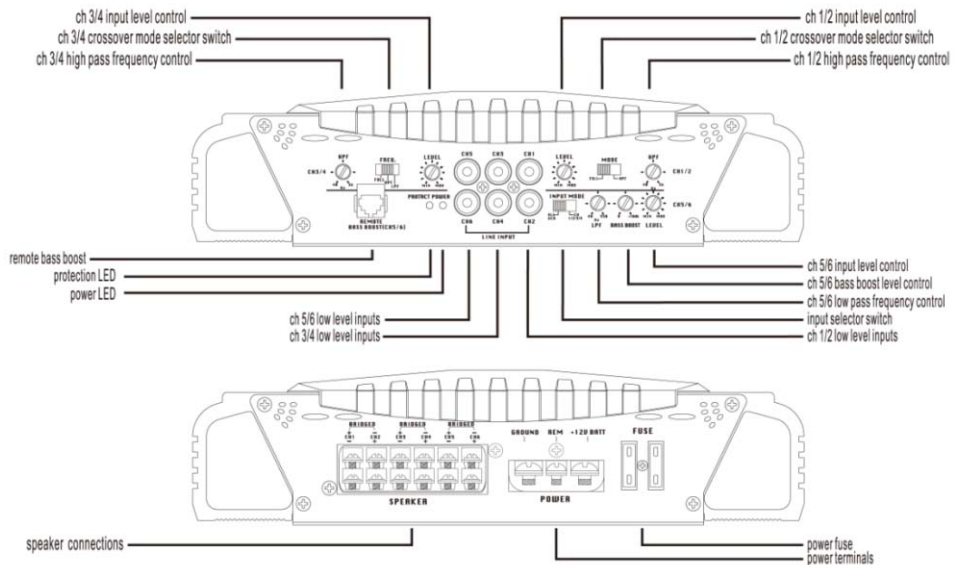

PLMRA630BT - Wiring

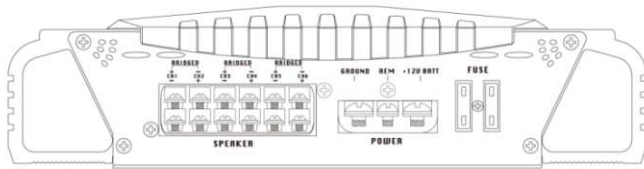

Electrical Connection

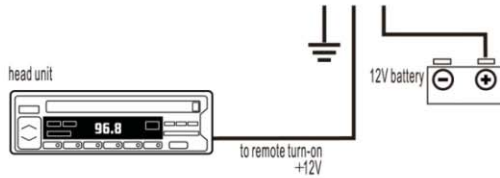

**4 Channel Inputs
RCA Low Level**

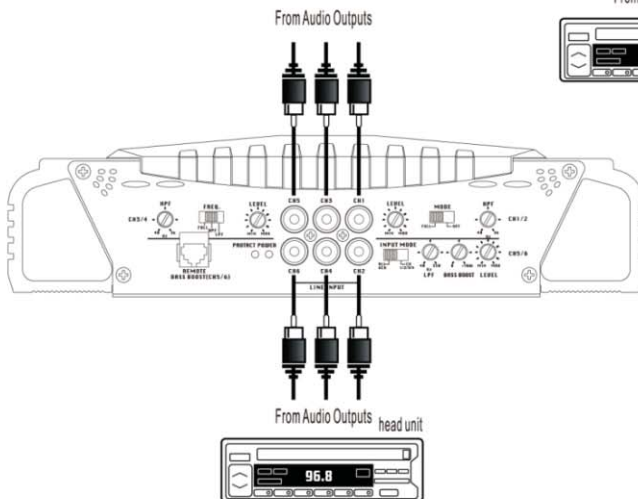
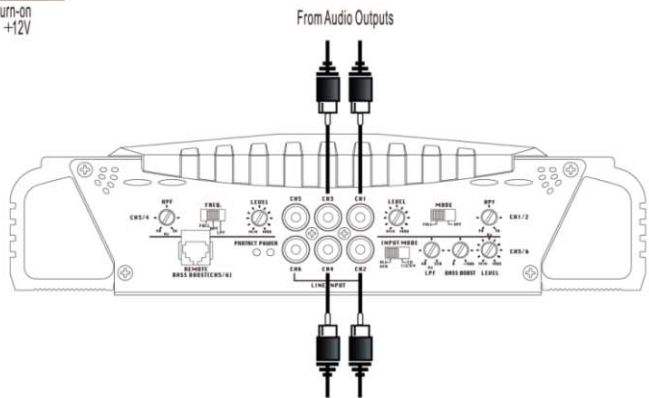

**Mono Input Connection
6 Channels**

PLMRA630BT - Wiring

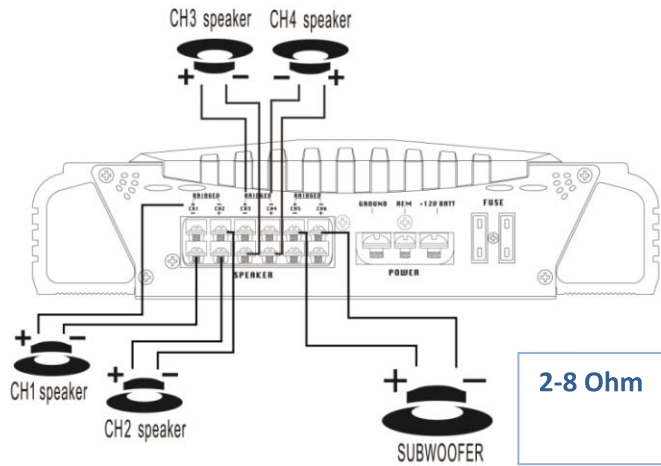
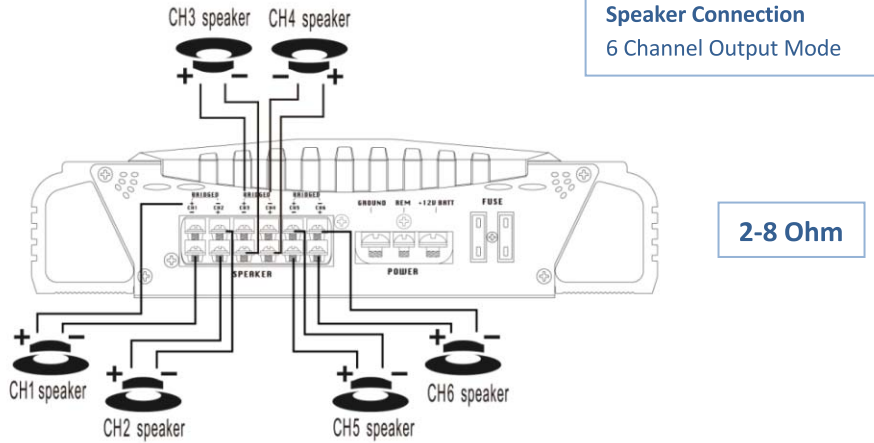

Speaker Connection
Mono Bridged Subwoofer Output

PLMRA830BT - Wiring

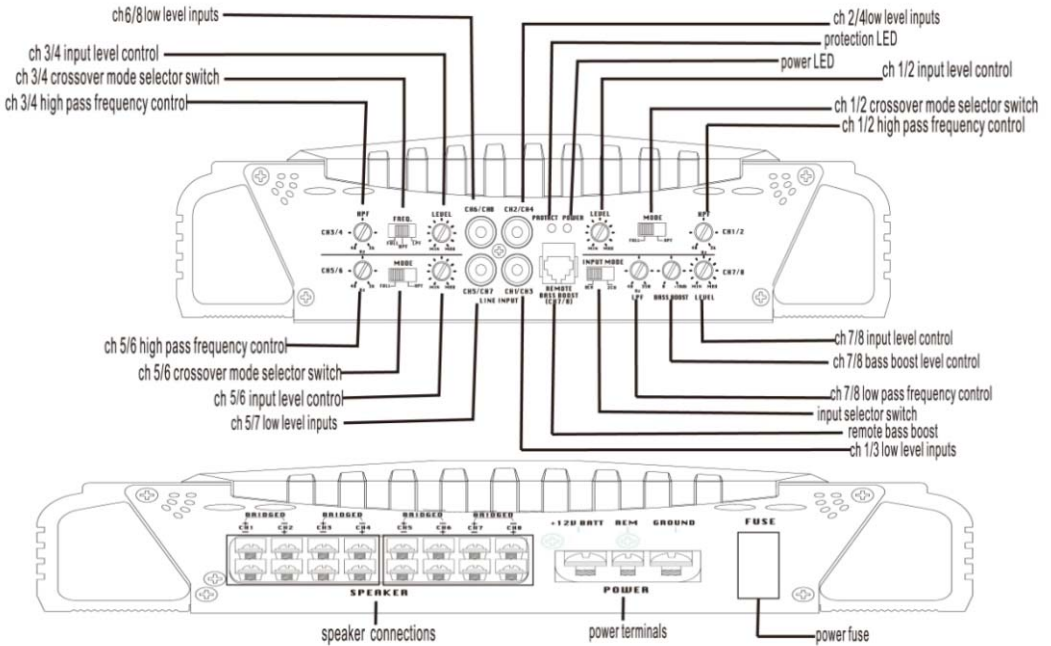
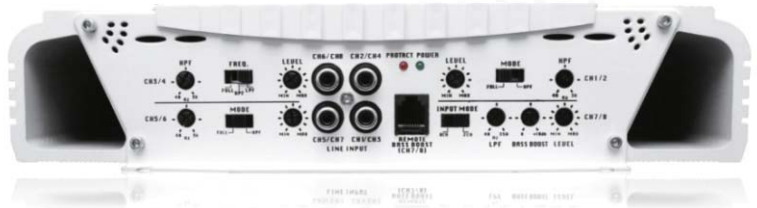

PLMRA830BT - Wiring

Electrical Connection

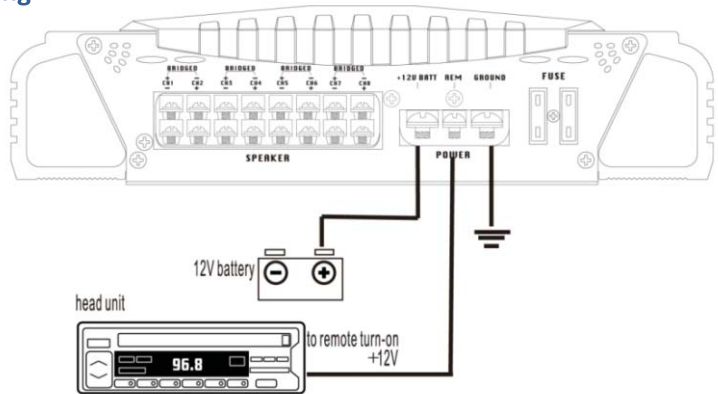

Multi Channel Input Connection

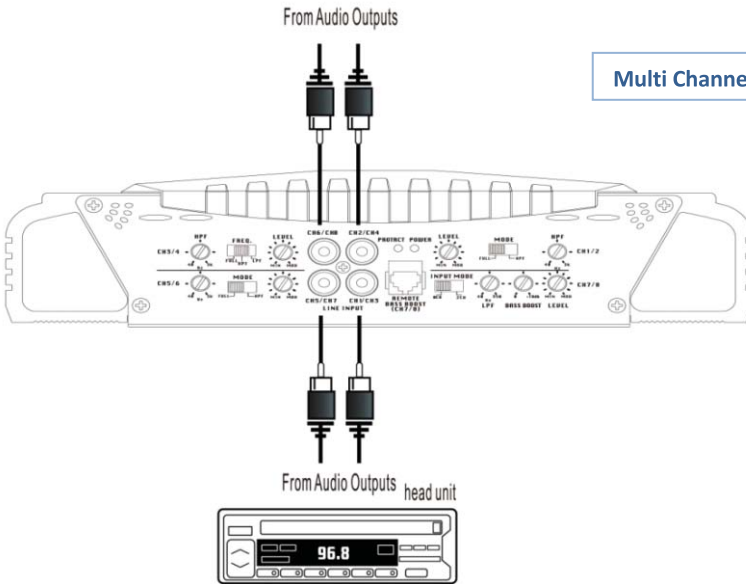

Visit www.PyleAudio.com for detailed model information, specific model wiring and connection ability.



PLMRA830BT - Wiring

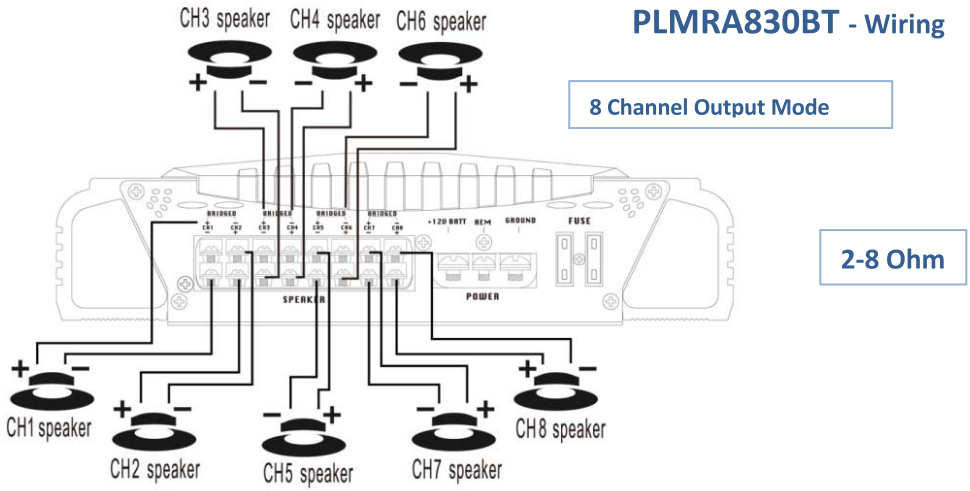

Mono Bridged Subwoofer Output

2-8 Ohm

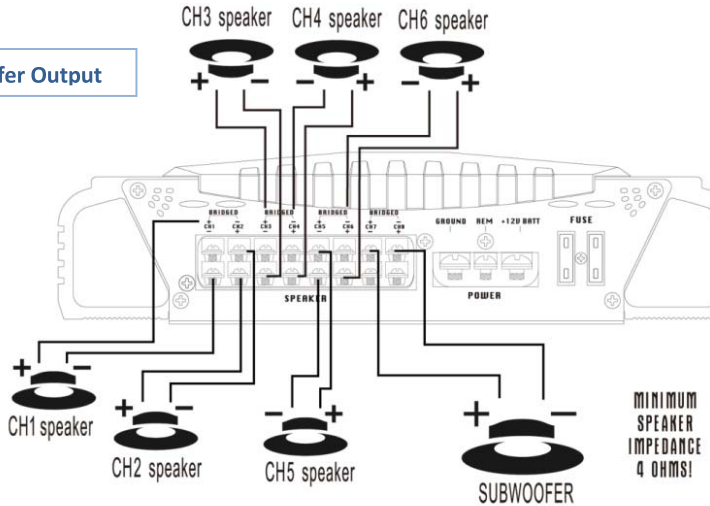

MINIMUM
SPEAKER
IMPEDANCE
4 OHMS!



Elite Series Bluetooth Connection

When searching for the amp via your smartphone or other Bluetooth-enabled device, the Bluetooth amp network name will appear as '**Pyle Amp**' in your device list. *The amp will not require a password to connect.* Once successfully paired with your compatible Bluetooth-enabled device, you will be able to control music streaming ability into the Pyle amp. Choose from streaming audio to adjusting volume controls -- all from your device.

Your amp comes with all required mounting hardware. When determining a suitable location in your vehicle for the amp, please remember that this is a high-power electronic device that is capable of generating high temperatures

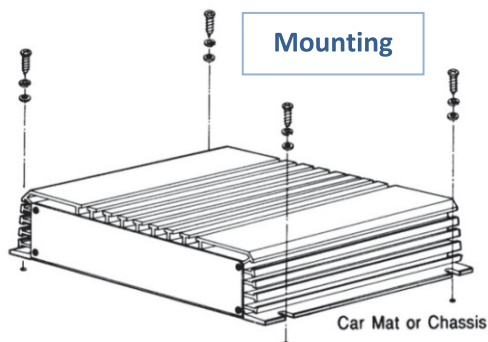

Mounting

Always choose a mounting location which will be susceptible to the least amount of vibration, provides adequate ventilation, free of dust and moisture. Be sure to mount the amp in such a manner as to allow reasonable airflow around the unit.

Mark the location for the mounting screw holes by positioning the amp in the desired location. Located on the outer edges of the amps, you will find notches in the heatsink that allow for the amp to be fastened. Mark the location for the mounting screw holes by positioning the amp where you wish to install it. Use a scribe (or one of the mounting screws) inserted in each of the mounting holes to mark the mounting surface. If the mounting surface is carpeted, measure the hole centers and mark with a felt tip pen.

Before attempting to drill the mounting holes and securing your amp, take note of any wires, lines or other devices within your vehicle which may be located behind the mounting surface. Be sure as to not interfere with any of your vehicle's safety features, wiring or other electrical systems. Then, drill the pilot holes in the mounting surface for the mounting screws. Tighten screws securely.

Mounting...

When making electrical connections with your amplifier and vehicle battery, please take precaution and have a professional, or install under the supervision of a professional.

Use the proper gauge wire for power and ground connections.

Wire the amplifier directly to the car battery.

For ground connection, use the shortest possible wire to a secure chassis ground.

Wire the remote connection to the auto start lead of your head unit, equalizer, or power antenna.

Circuitry Protection

Built-in fuse systems and circuitry protection protect both the amplifiers and your vehicle's electrical systems. If you ever need to replace the fuse, or feel your system has become faulty, please contact Pyle technical support, or consult the assistance of a trained professional. When replacing fuses, be sure to use **ONLY** a fuse of the exact same type and rating, otherwise may result in damage or fire.

The built-in protection circuitry in the amplifiers will disable the amplifier if it senses an input overload, a speaker short circuit, or extreme temperature conditions. When the protection circuit is activated by any of these conditions, the Protection LED will be illuminated. If this occurs, carefully inspect the system to determine the source of the problem.

- If the shutdown was a result of a thermal overload condition, allow the amplifier to cool down before attempting to restart.
- If the shutdown was a result of an input overload, or speaker short circuit, be sure to correct the condition before restarting. The amplifier can be restarted by turning the remote power OFF and then ON again.



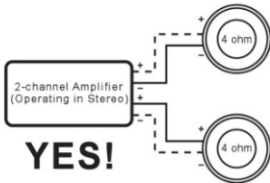

Two 4-ohm speakers, wired in stereo, will present a 4-ohm load to each channel of the amplifier. Most two-channel amplifiers will work well in this configuration.

SOUND AROUND, INC.
1600 63RD STREET, BROOKLYN, NY 11204

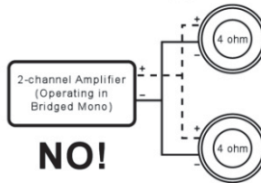

Two 4-ohm speakers, wired in parallel to a bridged two-channel amplifier, will present a 2-ohm mono load to the amplifier. **MOST TWO-CHANNEL AMPLIFIERS DO NOT SUPPORT 2-OHM MONO OPERATION! AMPLIFIER DAMAGE COULD RESULT!**

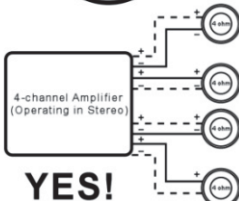

Four 4-ohm speakers, wired in stereo, will present a 4-ohm load to each channel of the amplifier. Most four-channel amplifiers will work well in this configuration.

SOUND AROUND, INC.
1600 63RD STREET, BROOKLYN, NY 11204

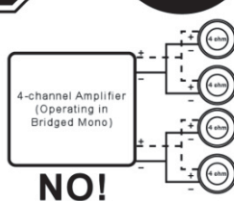

Four 4-ohm speakers, wired in parallel to a bridged four-channel amplifier, will present a 4-ohm mono load to the amplifier. **MOST FOUR-CHANNEL AMPLIFIERS DO NOT SUPPORT 2-OHM MONO OPERATION! AMPLIFIER DAMAGE COULD RESULT!**



FCC Caution:

This device complies with part 15 of the FCC Rules. Operation is subject to the following two conditions: (1) This device may not cause harmful interference, and (2) this device must accept any interference received, including interference that may cause undesired operation.

Any Changes or modifications not expressly approved by the party responsible for compliance could void the user's authority to operate the equipment.

Note: This equipment has been tested and found to comply with the limits for a Class B digital device, pursuant to part 15 of the FCC Rules. These limits are designed to provide reasonable protection against harmful interference in a residential installation. This equipment generates uses and can radiate radio frequency energy and, if not installed and used in accordance with the instructions, may cause harmful interference to radio communications. However, there is no guarantee that interference will not occur in a particular installation. If this equipment does cause harmful interference to radio or television reception, which can be determined by turning the equipment off and on, the user is encouraged to try to correct the interference by one or more of the following measures:

- Reorient or relocate the receiving antenna.
- Increase the separation between the equipment and receiver.
- Connect the equipment into an outlet on a circuit different from that to which the receiver is connected.
- Consult the dealer or an experienced radio/TV technician for help.

The device has been evaluated to meet general RF exposure requirement. The device can be used in portable exposure condition without restriction.