

# FCC TEST REPORT

Client Name : PLEVO LLC  
Address : 650 NE 64th Street, Miami FL 33138, United States  
Product Name : Plevo smart suitcase  
Date : Mar. 15, 2019

**Shenzhen Anbotech Compliance Laboratory Limited**

# Contents

1. General Information.....	5
1.1. Client Information.....	5
1.2. Description of Device (EUT).....	5
1.3. Auxiliary Equipment Used During Test.....	5
1.4. Description of Test Modes.....	6
1.5. List of channels.....	7
1.6. Description Of Test Setup.....	8
1.7. Test Equipment List.....	9
1.8. Measurement Uncertainty.....	10
1.9. Description of Test Facility.....	10
2. Summary of Test Results.....	11
3. Conducted Emission Test.....	12
3.1. Test Standard and Limit.....	12
3.2. Test Setup.....	12
3.3. Test Procedure.....	12
4. Radiation Spurious Emission and Band Edge.....	17
4.1. Test Standard and Limit.....	17
4.2. Test Setup.....	17
4.3. Test Procedure.....	18
4.4. Test Data.....	19
5. Maximum Peak Output Power Test.....	28
5.1. Test Standard and Limit.....	28
5.2. Test Setup.....	28
5.3. Test Procedure.....	28
5.4. Test Data.....	28
6. 6DB Occupy Bandwidth Test.....	32
6.1. Test Standard and Limit.....	32
6.2. Test Setup.....	32
6.3. Test Procedure.....	32
6.4. Test Data.....	32
7. Power Spectral Density Test.....	38
7.1. Test Standard and Limit.....	38
7.2. Test Setup.....	38
7.3. Test Procedure.....	38
7.4. Test Data.....	38
8. 100kHz Bandwidth of Frequency Band Edge Requirement.....	44
8.1. Test Standard and Limit.....	44
8.2. Test Setup.....	44

8.3. Test Procedure..... 44

8.4. Test Data..... 44

9. Antenna Requirement..... 53

9.1. Test Standard and Requirement..... 53

9.2. Antenna Connected Construction..... 53

APPENDIX I -- TEST SETUP PHOTOGRAPH..... 54

APPENDIX II -- PHOTOGRAPH..... 56

# TEST REPORT

Applicant : PLEVO LLC  
Manufacturer : PLEVO LLC  
Product Name : Plevo smart suitcase  
Model No. : Up, Runner, Infinite  
Trade Mark : Plevo  
Rating(s) : Input: DC 5V, 2A(with DC 3.6V, 600mAh Battery inside)  
**Test Standard(s) : FCC Part15 Subpart C 2018, Section 15.247**  
**Test Method(s) : ANSI C63.10: 2013, KDB558074 D01 DTS Meas Guidance v05**

The device described above is tested by Shenzhen Anbotek Compliance Laboratory Limited to determine the maximum emission levels emanating from the device and the severe levels of the device can endure and its performance criterion. The measurement results are contained in this test report and Shenzhen Anbotek Compliance Laboratory Limited is assumed full of responsibility for the accuracy and completeness of these measurements. Also, this report shows that the EUT (Equipment Under Test) is technically compliant with the FCC Part 15 Subpart C requirements.

This report applies to above tested sample only and shall not be reproduced in part without written approval of Shenzhen Anbotek Compliance Laboratory Limited.

Date of Receipt

Feb. 15, 2019

Date of Test

Feb. 15~Mar. 14, 2019

Prepared by



*Oliay Yang*

(Engineer / Oliay Yang)

Reviewer

*Snowy Meng*

(Supervisor / Snowy Meng)

Approved & Authorized Signer

*Sally Zhang*

(Manager / Sally Zhang)

## 1. General Information

### 1.1. Client Information

Applicant	:	PLEVO LLC
Address	:	650 NE 64th Street, Miami FL 33138, United States
Manufacturer	:	PLEVO LLC
Address	:	650 NE 64th Street, Miami FL 33138, United States
Manufacturer	:	DONGGUANSHI MEIERMEI TRAVELING APPLIANCE CO.LTD
Address	:	Tiegang Industrial Park Qishi Town Dongguan Guangdong China

### 1.2. Description of Device (EUT)

Product Name	:	Plevo smart suitcase	
Model No.	:	Up, Runner, Infinite (Note: All samples are the same except the Shell shape, size and color, so we prepare "Up" for test only.)	
Trade Mark	:	Plevo	
Test Power Supply	:	AC 240V, 60Hz for adapter/ AC 120V, 60Hz for adapter/ DC 3.6V Battery inside	
Test Sample No.	:	S1(Normal Sample), S2(Engineering Sample)	
Product Description	:	Operation Frequency:	802.11b/ g/ n(HT20) 2412-2462MHz
		Number of Channel:	11 Channels for 802.11b/ g/ n(HT20)
		Modulation Type:	802.11b CCK; 802.11g/n OFDM
		Antenna Type:	PIFA Antenna
		Antenna Gain(Peak):	3.86 dBi
<b>Remark:</b> 1)For a more detailed features description, please refer to the manufacturer's specifications or the User's Manual. 2)This report is for WIFI 2.4G.			

### 1.3. Auxiliary Equipment Used During Test

N/A	
-----	--

**1.4. Description of Test Modes**

To investigate the maximum EMI emission characteristics generates from EUT, the test system was pre-scanning tested base on the consideration of following EUT operation mode or test configuration mode which possible have effect on EMI emission level. Each of these EUT operation mode(s) or test configuration mode(s) mentioned above was evaluated respectively.

**RADIATED EMISSION TEST (BELOW 1GHz):**

Pre-Scan has been conducted to determine the worst-case mode from all possible combinations between available modulations, data rates, XYZ axis and antenna ports (if EUT with antenna diversity architecture).

Following channel(s) was (were) selected for the final test as listed below.

Mode	Available Channel	Test Channel	Modulation Tech.	Modulation Type	Data Rate (Mbps)
802.11b	1 to 11	1	CCK	DBPSK	1.0

For the test results, only the worst case was shown in test report.

**RADIATED EMISSION TEST (ABOVE 1GHz):**

Pre-Scan has been conducted to determine the worst-case mode from all possible combinations between available modulations, data rates, XYZ axis and antenna ports (if EUT with antenna diversity architecture).

Following channel(s) was (were) selected for the final test as listed below.

Mode	Available Channel	Test Channel	Modulation Tech.	Modulation Type	Data Rate (Mbps)
802.11b	1 to 11	1, 6, 11	CCK	DBPSK	1.0
802.11g	1 to 11	1, 6, 11	OFDM	BPSK	6.0
802.11n HT20	1 to 11	1, 6, 11	OFDM	BPSK	6.5

**POWER LINE CONDUCTED EMISSION TEST:**

The EUT was tested with the following mode

EUT configure mode	Test Mode
-	Keeping TX mode

**BANDEDGE MEASUREMENT:**

Pre-Scan has been conducted to determine the worst-case mode from all possible combinations between available modulations, data rates and antenna ports (if EUT with antenna diversity architecture).

Following channel(s) was (were) selected for the final test as listed below.

Mode	Available Channel	Test Channel	Modulation Tech.	Modulation Type	Data Rate (Mbps)
802.11b	1 to 11	1, 11	CCK	DBPSK	1.0
802.11g	1 to 11	1, 11	OFDM	BPSK	6.0

802.11n HT20	1 to 11	1, 11	OFDM	BPSK	6.5
--------------	---------	-------	------	------	-----

**ANTENNA PORT CONDUCTED MEASUREMENT:**

This item includes all test value of each mode, but only includes spectrum plot of worst value of each mode.

Pre-Scan has been conducted to determine the worst-case mode from all possible combinations between available modulations, data rates and antenna ports (if EUT with antenna diversity architecture).

Following channel(s) was (were) selected for the final test as listed below.

Mode	Available Channel	Test Channel	Modulation Tech.	Modulation Type	Data Rate (Mbps)
802.11b	1 to 11	1, 6, 11	CCK	DBPSK	1.0
802.11g	1 to 11	1, 6, 11	OFDM	BPSK	6.0
802.11n HT20	1 to 11	1, 6, 11	OFDM	BPSK	6.5

**1.5. List of channels**

Channel	Freq. (MHz)	Channel	Freq. (MHz)	Channel	Freq. (MHz)	Channel	Freq. (MHz)
01	2412	04	2427	07	2442	10	2457
02	2417	05	2432	08	2447	11	2462
03	2422	06	2437	09	2452		

### 1.6. Description Of Test Setup

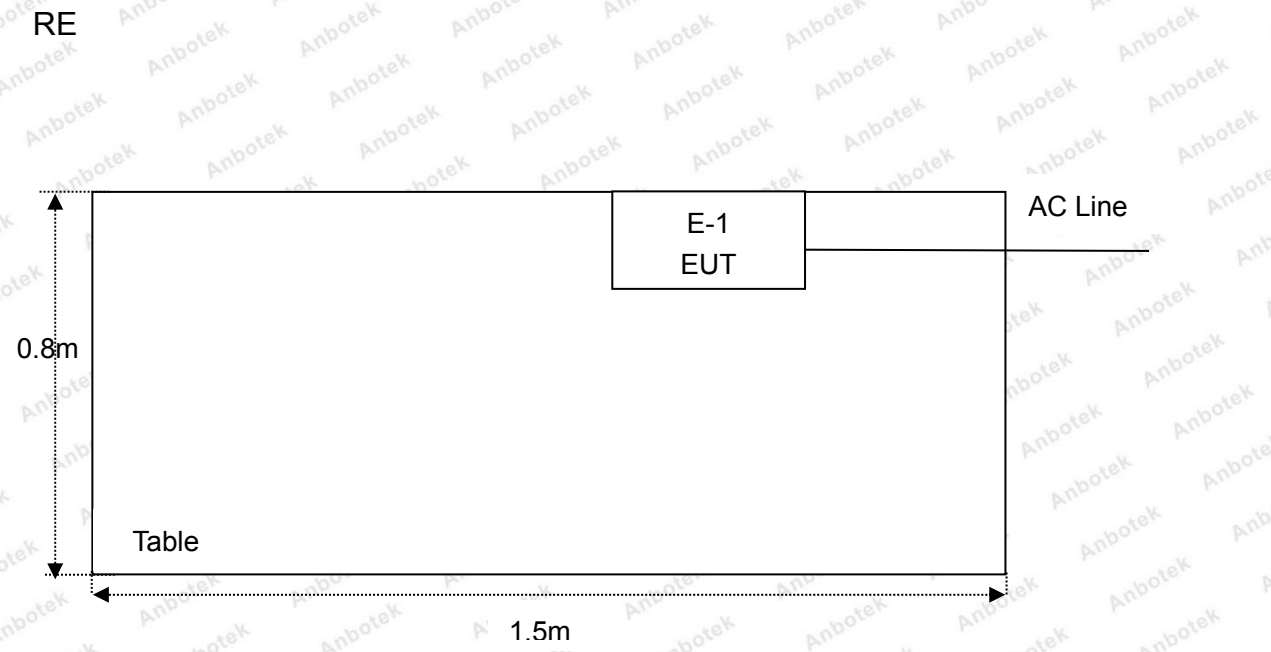
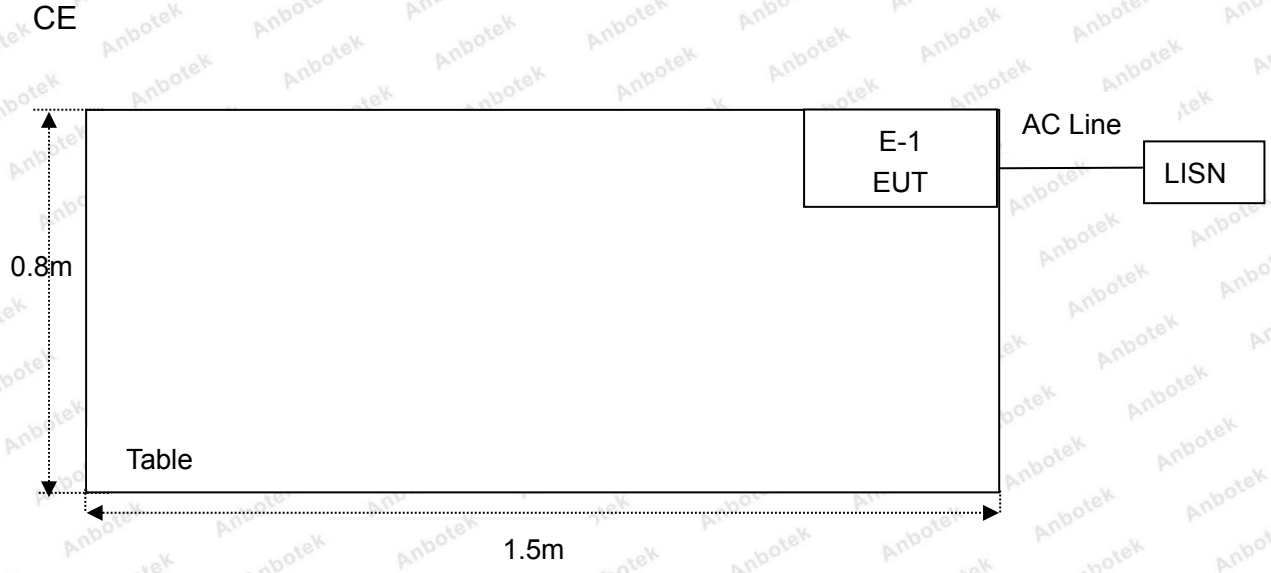



**1.7. Test Equipment List**

Item	Equipment	Manufacturer	Model No.	Serial No.	Last Cal.	Cal. Interval
1.	L.I.S.N. Artificial Mains Network	Rohde & Schwarz	ENV216	100055	Nov. 05, 2018	1 Year
2.	EMI Test Receiver	Rohde & Schwarz	ESPI3	101604	Nov. 05, 2018	1 Year
3.	RF Switching Unit	Compliance Direction	RSU-M2	38303	Nov. 05, 2018	1 Year
4.	Spectrum Analysis	Agilent	E4407B	US39390582	Nov. 05, 2018	1 Year
5.	MAX Spectrum Analysis	Agilent	N9020A	MY51170037	Nov. 05, 2018	1 Year
6.	Preamplifier	SKET Electronic	BK1G18G30D	KD17503	Nov. 05, 2018	1 Year
7.	Double Ridged Horn Antenna	Instruments corporation	GTH-0118	351600	Nov. 20, 2018	1 Year
8.	Bilog Broadband Antenna	Schwarzbeck	VULB9163	VULB 9163-289	Nov. 19, 2018	1 Year
9.	Loop Antenna	Schwarzbeck	FMZB1519B	00053	Nov. 20, 2018	1 Year
10.	Horn Antenna	A-INFO	LB-180400-K F	J211060628	Nov. 20, 2018	1 Year
11.	Pre-amplifier	SONOMA	310N	186860	Nov. 05, 2018	1 Year
12.	EMI Test Software EZ-EMC	SHURPLE	N/A	N/A	N/A	N/A
13.	RF Test Control System	YIHENG	YH3000	2017430	Nov. 05, 2018	1 Year
14.	Power Sensor	DAER	RPR3006W	15I00041SN045	Nov. 05, 2018	1 Year
15.	Power Sensor	DAER	RPR3006W	15I00041SN046	Nov. 05, 2018	1 Year
16.	MXA Spectrum Analysis	Agilent	N9020A	MY51170037	Nov. 05, 2018	1 Year
17.	MXG RF Vector Signal Generator	Agilent	N5182A	MY48180656	Nov. 05, 2018	1 Year
18.	Signal Generator	Agilent	E4421B	MY41000743	Nov. 05, 2018	1 Year
19.	DC Power Supply	IVYTECH	IV3605	1804D360510	Apr. 02, 2018	1 Year
20.	Constant Temperature Humidity Chamber	ZHONGJIAN	ZJ-KHWS80B	N/A	Nov. 01, 2018	1 Year

**1.8. Measurement Uncertainty**

Radiation Uncertainty	:	Ur = 3.9 dB (Horizontal)
		Ur = 3.8 dB (Vertical)
Conduction Uncertainty	:	Uc = 3.4 dB

**1.9. Description of Test Facility**

The test facility is recognized, certified, or accredited by the following organizations:

**FCC-Registration No.: 184111**

Shenzhen Anbotek Compliance Laboratory Limited, EMC Laboratory has been registered and fully described in a report filed with the (FCC) Federal Communications Commission. The acceptance letter from the FCC is maintained in our files. Registration No. 184111, July 31, 2017.

**ISED-Registration No.: 8058A-1**

Shenzhen Anbotek Compliance Laboratory Limited, EMC Laboratory has been registered and fully described in a report filed with the (ISED) Innovation, Science and Economic Development Canada. The acceptance letter from the ISED is maintained in our files. Registration 8058A-1, June 13, 2016.

**Test Location**

Shenzhen Anbotek Compliance Laboratory Limited.

1/F, Building D, Sogood Science and Technology Park, Sanwei community, Hangcheng Street, Bao'an District, Shenzhen, Guangdong, China.518102

## 2. Summary of Test Results

Standard Section	Test Item	Result
15.203/15.247(c)	Antenna Requirement	PASS
15.207	Conducted Emission	PASS
15.205/15.209	Spurious Emission	PASS
15.247(b)(3)	Conducted Peak Output Power	PASS
15.247(a)(2)	6dB Occupied Bandwidth	PASS
15.247(e)	Power Spectral Density	PASS
15.247(d)	Band Edge	PASS
<b>Remark:</b> "N/A" is an abbreviation for Not Applicable.		

### 3. Conducted Emission Test

#### 3.1. Test Standard and Limit

Test Standard	FCC Part15 Section 15.207		
Test Limit	Frequency	Maximum RF Line Voltage (dBuV)	
		Quasi-peak Level	Average Level
	150kHz~500kHz	66 ~ 56 *	56 ~ 46 *
	500kHz~5MHz	56	46
	5MHz~30MHz	60	50

**Remark:** (1) \*Decreasing linearly with logarithm of the frequency.  
 (2) The lower limit shall apply at the transition frequency.

#### 3.2. Test Setup

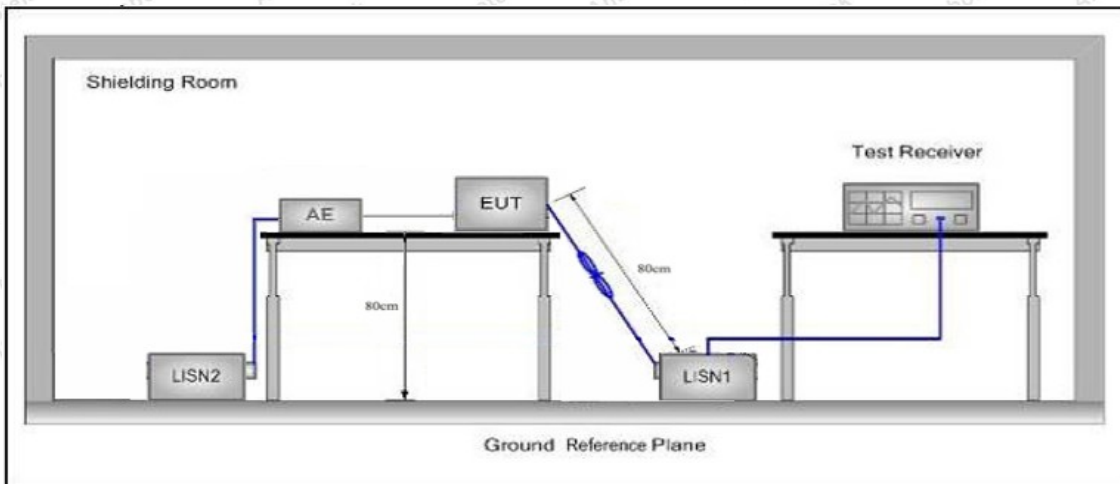

#### 3.3. Test Procedure

The EUT system is connected to the power mains through a line impedance stabilization network (L.I.S.N.). This provides a 50ohm coupling impedance for the EUT system. Please refer the block diagram of the test setup and photographs. Both sides of AC line are checked to find out the maximum conducted emission. In order to find the maximum emission levels, the relative positions of equipment and all of the interface cables shall be changed according to FCC ANSI C63.10-2013 on Conducted Emission Measurement.

The bandwidth of test receiver (ESCI) set at 9kHz.

The frequency range from 150kHz to 30MHz is checked.

#### 3.4. Test Data

During the test, pre-scan all modes, and found the 802.11b CH01 which is the worst case, only the worst case is recorded in the report.

### Conducted Emission Test Data

Test Site: 1# Shielded Room  
 Operating Condition: 802.11b CH01  
 Test Specification: AC 120V, 60Hz  
 Comment: Live Line  
 Tem.: 23.1°C Hum.: 57%

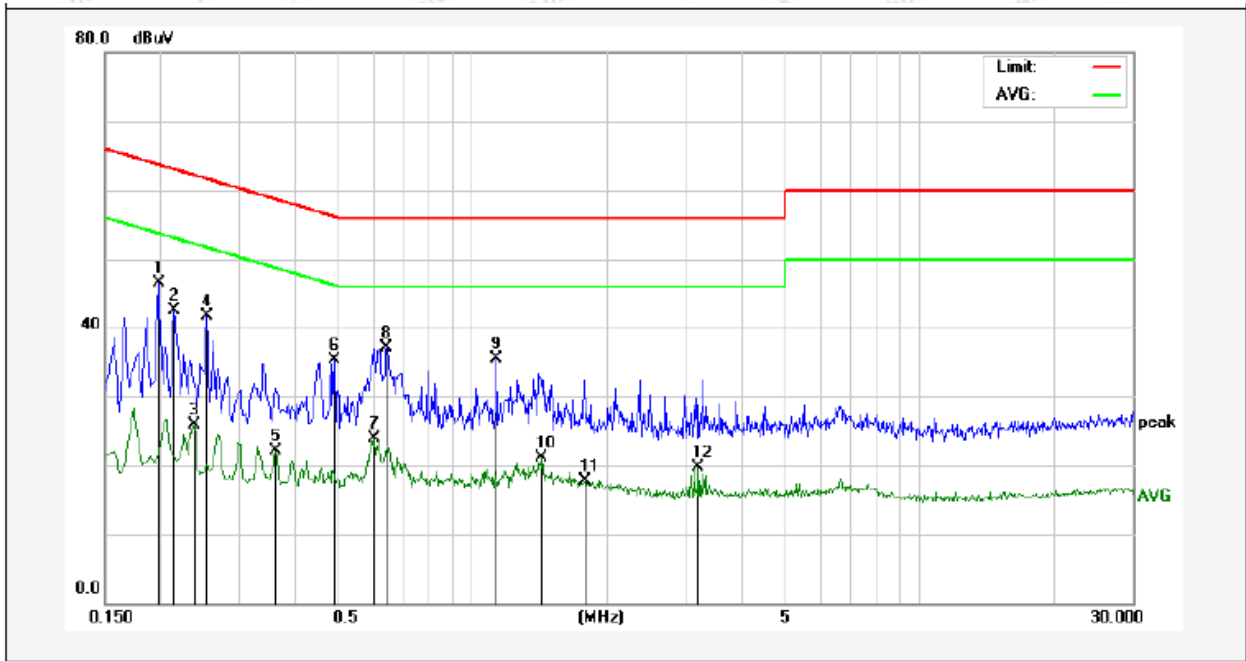

No.	Freq. (MHz)	Reading (dBuV)	Factor (dB)	Result (dBuV)	Limit dBuV	Over Limit (dB)	Detector	Remark
1	0.1980	26.69	19.90	46.59	63.69	-17.10	QP	
2	0.2140	22.54	19.90	42.44	63.04	-20.60	QP	
3	0.2380	5.95	19.89	25.84	52.16	-26.32	AVG	
4	0.2540	21.74	19.89	41.63	61.62	-19.99	QP	
5	0.3620	2.24	19.92	22.16	48.68	-26.52	AVG	
6	0.4900	15.23	19.98	35.21	56.17	-20.96	QP	
7	0.6020	3.92	20.01	23.93	46.00	-22.07	AVG	
8	0.6419	17.13	20.02	37.15	56.00	-18.85	QP	
9	1.1340	15.48	20.12	35.60	56.00	-20.40	QP	
10	1.4299	0.97	20.13	21.10	46.00	-24.90	AVG	
11	1.7820	-2.49	20.14	17.65	46.00	-28.35	AVG	
12	3.1980	-0.44	20.16	19.72	46.00	-26.28	AVG	

### Conducted Emission Test Data

Test Site: 1# Shielded Room  
 Operating Condition: 802.11b CH01  
 Test Specification: AC 120V, 60Hz  
 Comment: Neutral Line  
 Tem.: 23.1°C Hum.: 57%

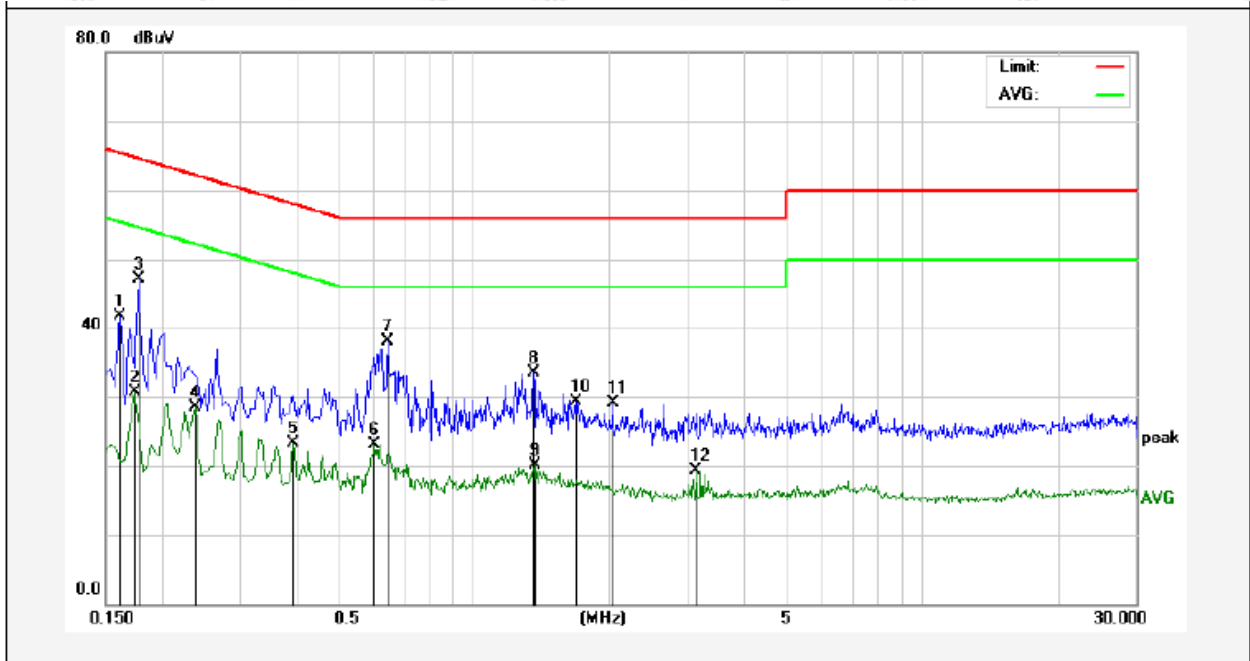

No.	Freq. (MHz)	Reading (dBuV)	Factor (dB)	Result (dBuV)	Limit dBuV	Over Limit (dB)	Detector	Remark
1	0.1620	21.87	19.90	41.77	65.36	-23.59	QP	
2	0.1740	10.88	19.90	30.78	54.76	-23.98	AVG	
3	0.1780	27.15	19.90	47.05	64.57	-17.52	QP	
4	0.2380	8.55	19.89	28.44	52.16	-23.72	AVG	
5	0.3940	3.33	19.93	23.26	47.98	-24.72	AVG	
6	0.5980	3.04	20.01	23.05	46.00	-22.95	AVG	
7	0.6419	18.06	20.02	38.08	56.00	-17.92	QP	
8	1.3580	13.38	20.13	33.51	56.00	-22.49	QP	
9	1.3660	0.01	20.13	20.14	46.00	-25.86	AVG	
10	1.6820	9.19	20.13	29.32	56.00	-26.68	QP	
11	2.0380	9.04	20.14	29.18	56.00	-26.82	QP	
12	3.1380	-0.91	20.16	19.25	46.00	-26.75	AVG	

### Conducted Emission Test Data

Test Site: 1# Shielded Room  
 Operating Condition: 802.11b CH01  
 Test Specification: AC 240V, 60Hz  
 Comment: Live Line  
 Tem.: 23.1°C Hum.: 57%

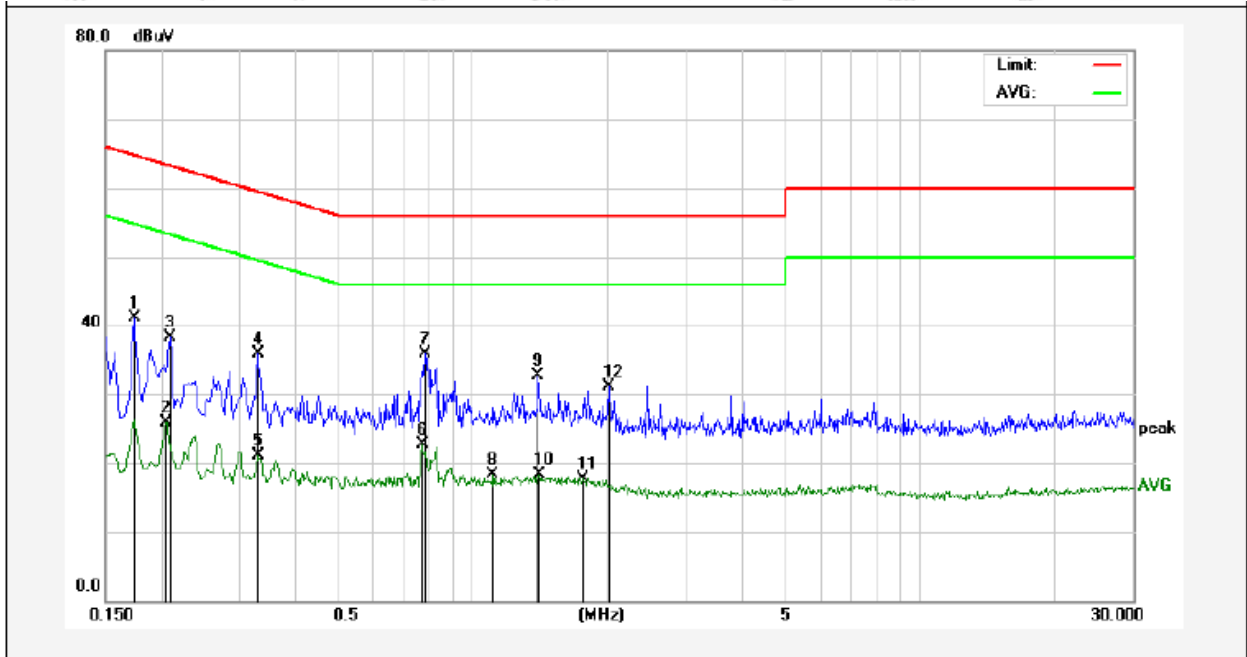

No.	Freq. (MHz)	Reading (dBuV)	Factor (dB)	Result (dBuV)	Limit dBuV	Over Limit (dB)	Detector	Remark
1	0.1740	21.20	19.90	41.10	64.76	-23.66	QP	
2	0.2060	6.05	19.90	25.95	53.36	-27.41	AVG	
3	0.2100	18.43	19.90	38.33	63.20	-24.87	QP	
4	0.3300	15.98	19.90	35.88	59.45	-23.57	QP	
5	0.3300	1.24	19.90	21.14	49.45	-28.31	AVG	
6	0.7700	2.71	20.06	22.77	46.00	-23.23	AVG	
7	0.7820	15.94	20.06	36.00	56.00	-20.00	QP	
8	1.1060	-1.84	20.12	18.28	46.00	-27.72	AVG	
9	1.4020	12.53	20.13	32.66	56.00	-23.34	QP	
10	1.4060	-1.81	20.13	18.32	46.00	-27.68	AVG	
11	1.7700	-2.42	20.14	17.72	46.00	-28.28	AVG	
12	2.0220	11.02	20.14	31.16	56.00	-24.84	QP	

### Conducted Emission Test Data

Test Site: 1# Shielded Room  
 Operating Condition: 802.11b CH01  
 Test Specification: AC 240V, 60Hz  
 Comment: Neutral Line  
 Tem.: 23.1°C Hum.: 57%

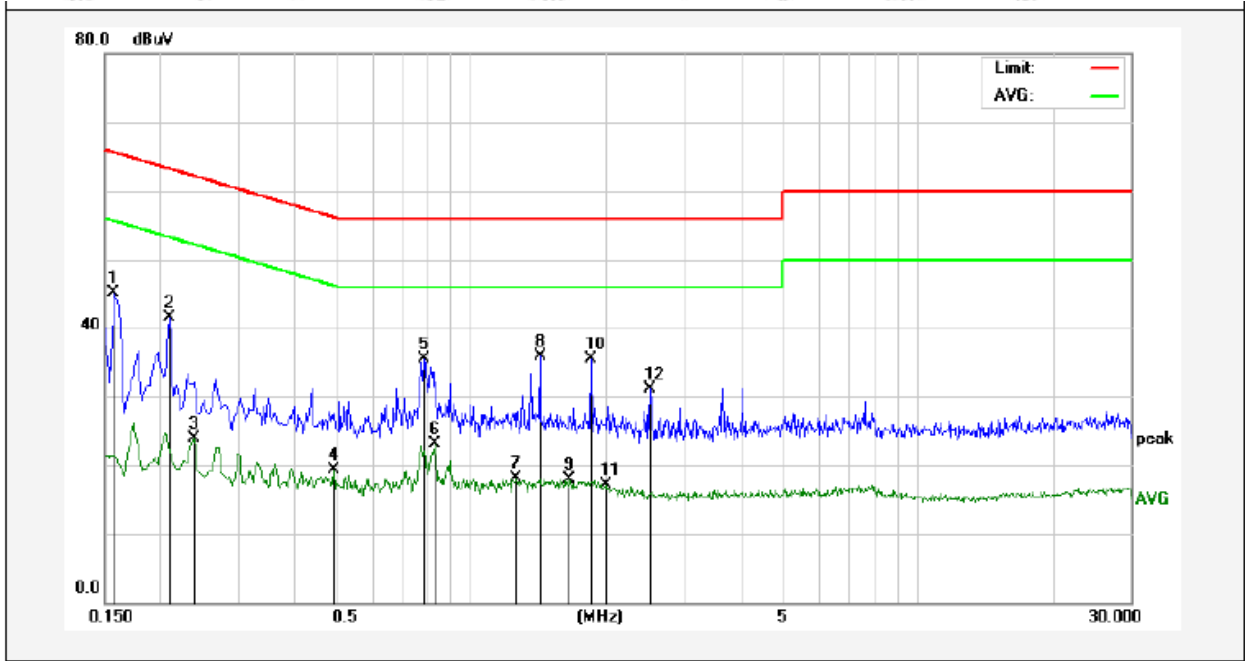

No.	Freq. (MHz)	Reading (dBuV)	Factor (dB)	Result (dBuV)	Limit dBuV	Over Limit (dB)	Detector	Remark
1	0.1580	25.13	19.90	45.03	65.56	-20.53	QP	
2	0.2100	21.66	19.90	41.56	63.20	-21.64	QP	
3	0.2380	3.97	19.89	23.86	52.16	-28.30	AVG	
4	0.4900	-0.65	19.98	19.33	46.17	-26.84	AVG	
5	0.7820	15.48	20.06	35.54	56.00	-20.46	QP	
6	0.8300	3.03	20.07	23.10	46.00	-22.90	AVG	
7	1.2620	-2.08	20.13	18.05	46.00	-27.95	AVG	
8	1.4220	15.86	20.13	35.99	56.00	-20.01	QP	
9	1.6580	-2.17	20.13	17.96	46.00	-28.04	AVG	
10	1.8580	15.35	20.14	35.49	56.00	-20.51	QP	
11	1.9980	-3.02	20.14	17.12	46.00	-28.88	AVG	
12	2.5020	10.96	20.15	31.11	56.00	-24.89	QP	



## 4. Radiation Spurious Emission and Band Edge

### 4.1. Test Standard and Limit

Test Standard	FCC Part15 C Section 15.209 and 15.205				
Test Limit	Frequency (MHz)	Field strength (microvolt/meter)	Limit (dBuV/m)	Remark	Measurement distance (m)
	0.009MHz~0.490MHz	2400/F(kHz)	-	-	300
	0.490MHz-1.705MHz	24000/F(kHz)	-	-	30
	1.705MHz-30MHz	30	-	-	30
	30MHz~88MHz	100	40.0	Quasi-peak	3
	88MHz~216MHz	150	43.5	Quasi-peak	3
	216MHz~960MHz	200	46.0	Quasi-peak	3
	960MHz~1000MHz	500	54.0	Quasi-peak	3
	Above 1000MHz	500	54.0	Average	3
-		74.0	Peak	3	

**Remark:**

- (1)The lower limit shall apply at the transition frequency.
- (2) 15.35(b), Unless otherwise specified, the limit on peak radio frequency emissions is 20dB above the maximum permitted average emission limit applicable to the equipment under test. This peak limit applies to the total peak emission level radiated by the device.

### 4.2. Test Setup

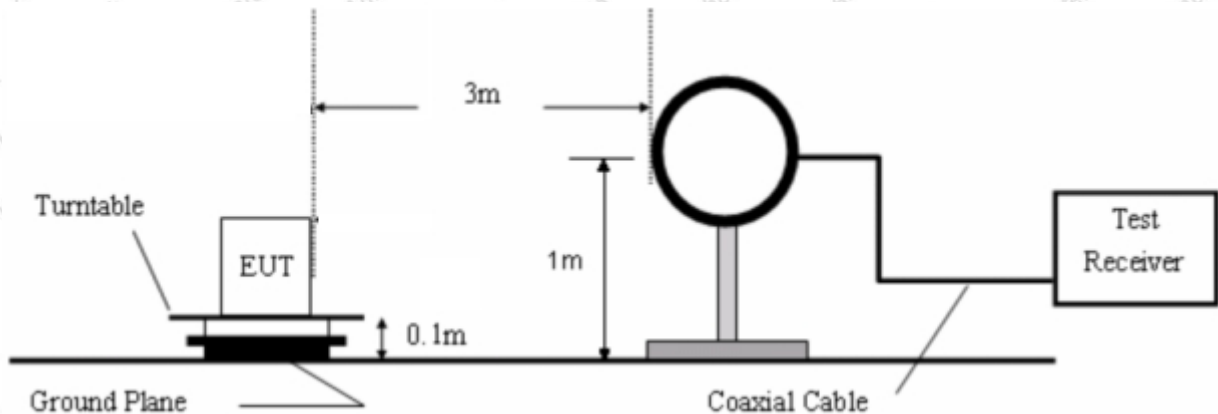

Figure 1. Below 30MHz

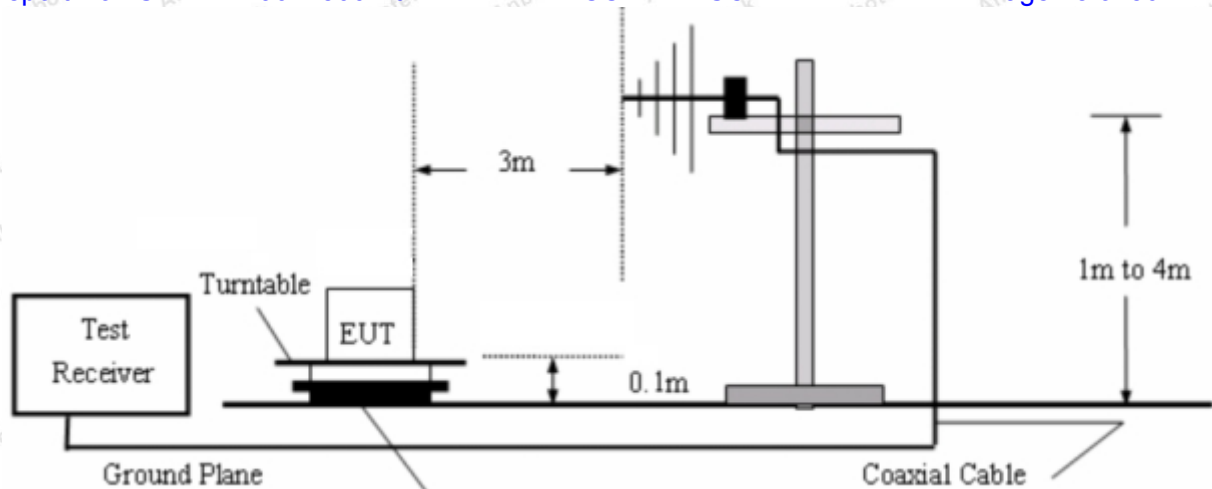

Figure 2. 30MHz to 1GHz

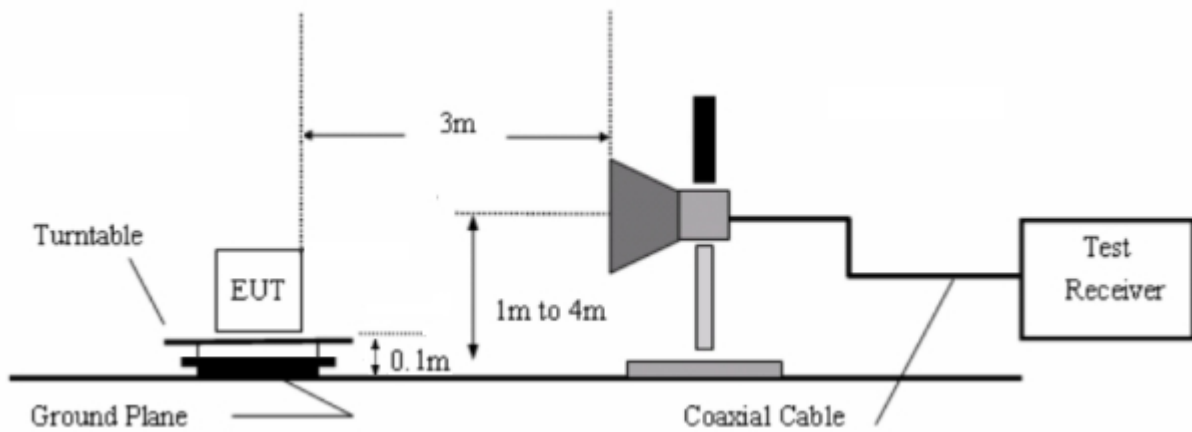

Figure 3. Above 1 GHz

### 4.3. Test Procedure

For below 1GHz: The EUT is placed on a turntable, which is 0.8m above the ground plane.

For above 1GHz: The EUT is placed on a turntable, which is 1.5m above the ground plane.

The turn table can rotate 360 degrees to determine the position of the maximum emission level. The EUT is set 3 meters away from the receiving antenna which is mounted on a antenna tower. The antenna can be moved up and down from 1 to 4 meters to find out the maximum emission level. Rotated the EUT through three orthogonal axes to determine the maximum emissions, both horizontal and vertical polarization of the antenna are set on test. The EUT is tested in 9\*6\*6 Chamber. The device is evaluated in xyz orientation.

For the radiated emission test above 1GHz:

Place the measurement antenna away from each area of the EUT determined to be a source of emissions at the specified measurement distance, while keeping the measurement antenna aimed at the source of emissions at each frequency of significant emissions, with polarization oriented for maximum response. The measurement antenna may have to be higher or lower than the EUT, depending on the

radiation pattern of the emission and staying aimed at the emission source for receiving the maximum signal. The final measurement antenna elevation shall be that which maximizes the emissions. The measurement antenna elevation for maximum emissions shall be restricted to a range of heights of from 1 m to 4 m above the ground or reference ground plane.

For 9kHz to 150kHz, Set the spectrum analyzer as:

RBW = 200Hz, VBW = 1kHz, Detector= Quasi-Peak, Trace mode= Max hold, Sweep- auto couple.

For 150kHz to 30MHz, Set the spectrum analyzer as:

RBW = 9kHz, VBW = 30kHz, Detector= Quasi-Peak, Trace mode= Max hold, Sweep- auto couple.

For 30MHz to 1000MHz, Set the spectrum analyzer as:

RBW = 100kHz, VBW = 300kHz, Detector= Quasi-Peak, Trace mode= Max hold, Sweep- auto couple.

For above 1GHz, Set the spectrum analyzer as:

RBW = 1MHz, VBW = 1MHz, Detector= Peak, Trace mode= Max hold, Sweep- auto couple.

RBW = 1MHz, VBW = 10Hz, Detector= Average, Trace mode= Max hold, Sweep- auto couple.

#### 4.4. Test Data

##### PASS

During the test, Pre-scan all kind of the place mode (X-axis, Y-axis, Z-axis), and found the X-axis is the worst case.

The test results of 9kHz-30MHz was attenuated more than 20dB below the permissible limits, so the results don't record in the report.

During the test, pre-scan all modes, and found the 802.11b CH01 which is the worst case, only the worst case is recorded in the report.

### Test Results (30~1000MHz)

Job No.: SZAWW190215004-02

Temp.(°C)/Hum.(%RH): 23.6°C/54%RH

Standard: FCC PART 15C

Power Source: DC 3.6V battery inside

Test Mode: 802.11b CH01

Polarization: Horizontal

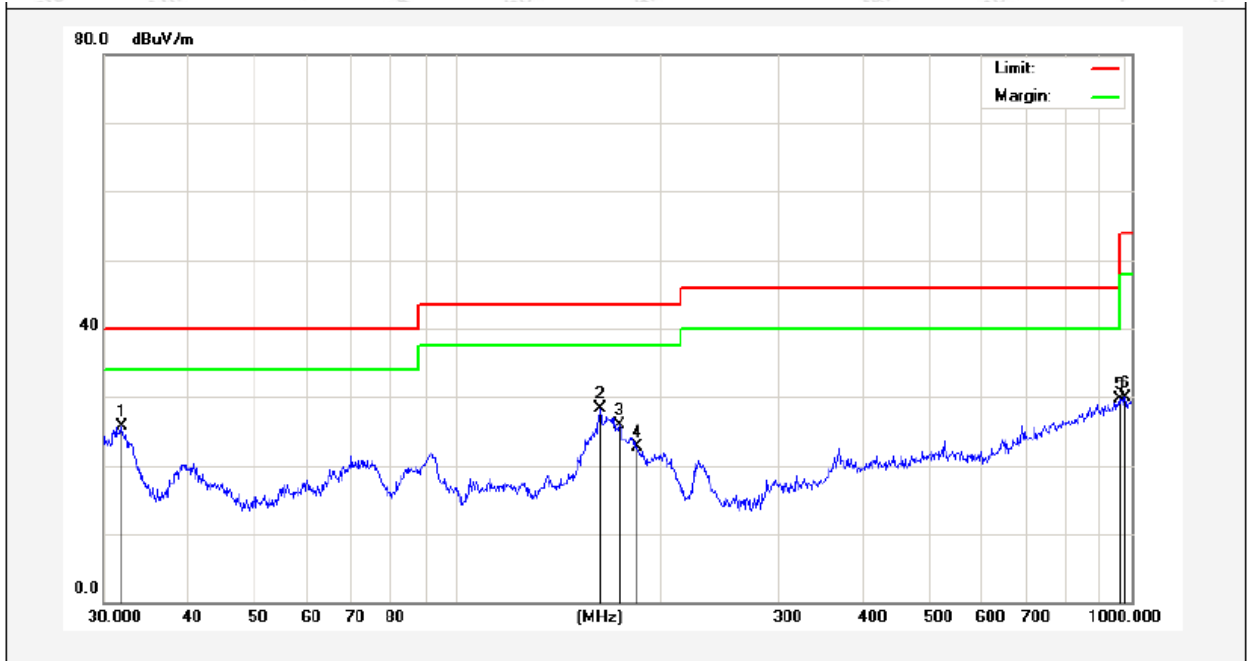

No.	Freq. (MHz)	Reading (dBuV)	Factor (dB/m)	Result (dBuV/m)	Limit (dBuV/m)	Over Limit (dB)	Detector	Height (cm)	degree (deg)	Remark
1	31.9546	43.66	-17.98	25.68	40.00	-14.32	QP	300	0	
2	163.1818	49.84	-21.46	28.38	43.50	-15.12	QP	300	64	
3	174.4241	46.57	-20.69	25.88	43.50	-17.62	QP	300	122	
4	185.1379	43.53	-20.88	22.65	43.50	-20.85	QP	300	222	
5	958.7943	33.57	-3.83	29.74	46.00	-16.26	QP	300	232	
6	979.1804	33.45	-3.49	29.96	54.00	-24.04	QP	300	360	

Report No.: SZAWW190215004-02

FCC ID: 2ASOM-PERI

Page 21 of 56

### Test Results (30~1000MHz)

Job No.: SZAWW190215004-02

Temp.(°C)/Hum.(%RH):

23.6°C/54%RH

Standard: FCC PART 15C

Power Source:

DC 3.6V battery inside

Test Mode: 802.11b CH01

Polarization:

Vertical

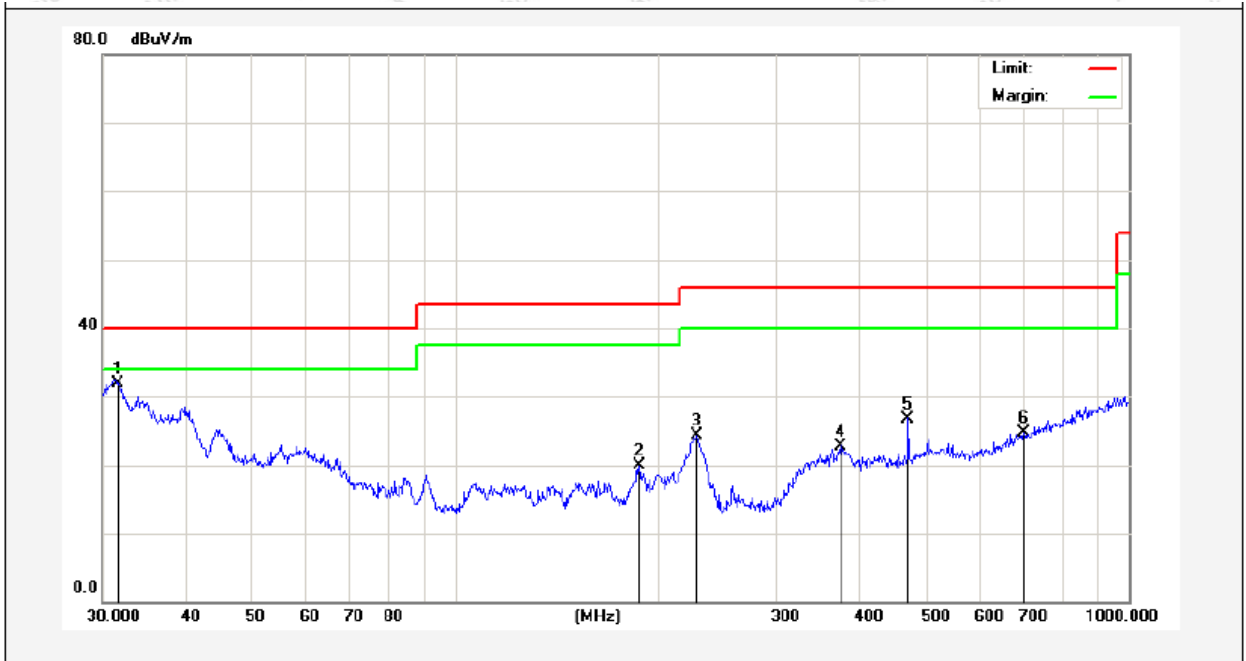

No.	Freq. (MHz)	Reading (dBuV)	Factor (dB/m)	Result (dBuV/m)	Limit (dBuV/m)	Over Limit (dB)	Detector	Height (cm)	degree (deg)	Remark
1	31.6202	48.99	-17.08	31.91	40.00	-8.09	QP	300	0	
2	187.7530	36.09	-16.14	19.95	43.50	-23.55	QP	300	77	
3	228.4904	39.22	-14.96	24.26	46.00	-21.74	QP	300	154	
4	373.3112	35.46	-12.66	22.80	46.00	-23.20	QP	300	199	
5	470.5232	38.61	-11.81	26.80	46.00	-19.20	QP	300	242	
6	699.3046	33.28	-8.48	24.80	46.00	-21.20	QP	300	360	

**Test Results (Above 1000MHz)**

Test Mode: 802.11b Mode					Test channel: Lowest			
Peak Value								
Frequency (MHz)	Read Level (dBuV)	Antenna Factor (dB/m)	Cable Loss (dB)	Preamp Factor (dB)	Level (dBuV/m)	Limit (dBuV/m)	Over Limit (dB)	Pol.
4824.00	40.11	34.13	6.61	34.09	46.76	74.00	-27.24	V
7236.00	34.10	37.14	7.74	34.51	44.47	74.00	-29.53	V
9648.00	32.63	39.35	9.26	34.80	46.44	74.00	-27.56	V
12060.00	*					74.00		V
14472.00	*					74.00		V
16884.00	*					74.00		V
4824.00	38.81	34.13	6.61	34.09	45.46	74.00	-28.54	H
7236.00	33.87	37.14	7.74	34.51	44.24	74.00	-29.76	H
9648.00	32.22	39.35	9.26	34.80	46.03	74.00	-27.97	H
12060.00	*					74.00		H
14472.00	*					74.00		H
16884.00	*					74.00		H
Average Value								
Frequency (MHz)	Read Level (dBuV)	Antenna Factor (dB/m)	Cable Loss (dB)	Preamp Factor (dB)	Level (dBuV/m)	Limit (dBuV/m)	Over Limit (dB)	Pol.
4824.00	29.21	34.13	6.61	34.09	35.86	54.00	-18.14	V
7236.00	22.98	37.14	7.74	34.51	33.35	54.00	-20.65	V
9648.00	22.98	39.35	9.26	34.80	36.79	54.00	-17.21	V
12060.00	*					54.00		V
14472.00	*					54.00		V
16884.00	*					54.00		V
4824.00	28.36	34.13	6.61	34.09	35.01	54.00	-18.99	H
7236.00	22.45	37.14	7.74	34.51	32.82	54.00	-21.18	H
9648.00	21.97	39.35	9.26	34.80	35.78	54.00	-18.22	H
12060.00	*					54.00		H
14472.00	*					54.00		H
16884.00	*					54.00		H

**Test Results (Above 1000MHz)**

Test Mode: 802.11b Mode					Test channel: Middle			
Peak Value								
Frequency (MHz)	Read Level (dBuV)	Antenna Factor (dB/m)	Cable Loss (dB)	Preamp Factor (dB)	Level (dBuV/m)	Limit (dBuV/m)	Over Limit (dB)	Pol.
4874.00	39.20	34.35	6.67	34.09	46.13	74.00	-27.87	V
7311.00	34.20	37.21	7.77	34.53	44.65	74.00	-29.35	V
9748.00	33.66	39.45	9.33	34.80	47.64	74.00	-26.36	V
12185.00	*					74.00		V
14622.00	*					74.00		V
17059.00	*					74.00		V
4874.00	39.70	34.35	6.67	34.09	46.63	74.00	-27.37	H
7311.00	32.85	37.21	7.77	34.53	43.30	74.00	-30.70	H
9748.00	33.56	39.45	9.33	34.80	47.54	74.00	-26.46	H
12185.00	*					74.00		H
14622.00	*					74.00		H
17059.00	*					74.00		H
Average Value								
Frequency (MHz)	Read Level (dBuV)	Antenna Factor (dB/m)	Cable Loss (dB)	Preamp Factor (dB)	Level (dBuV/m)	Limit (dBuV/m)	Over Limit (dB)	Pol.
4874.00	30.07	34.35	6.67	34.09	37.00	54.00	-17.00	V
7311.00	22.51	37.21	7.77	34.53	32.96	54.00	-21.04	V
9748.00	22.92	39.45	9.33	34.80	36.90	54.00	-17.10	V
12185.00	*					54.00		V
14622.00	*					54.00		V
17059.00	*					54.00		V
4874.00	29.82	34.35	6.67	34.09	36.75	54.00	-17.25	H
7311.00	21.94	37.21	7.77	34.53	32.39	54.00	-21.61	H
9748.00	23.28	39.45	9.33	34.80	37.26	54.00	-16.74	H
12185.00	*					54.00		H
14622.00	*					54.00		H
17059.00	*					54.00		H

**Test Results (Above 1000MHz)**

Test Mode: 802.11b Mode					Test channel: Highest			
Peak Value								
Frequency (MHz)	Read Level (dBuV)	Antenna Factor (dB/m)	Cable Loss (dB)	Preamp Factor (dB)	Level (dBuV/m)	Limit (dBuV/m)	Over Limit (dB)	Pol.
4924.00	44.62	34.57	6.74	34.09	51.84	74.00	-22.16	V
7386.00	34.80	37.29	7.80	34.55	45.34	74.00	-28.66	V
9848.00	36.91	39.55	9.41	34.81	51.06	74.00	-22.94	V
12310.00	*					74.00		V
14772.00	*					74.00		V
17234.00	*					74.00		V
4924.00	43.97	34.57	6.74	34.09	51.19	74.00	-22.81	H
7386.00	33.72	37.29	7.80	34.55	44.26	74.00	-29.74	H
9848.00	33.09	39.55	9.41	34.81	47.24	74.00	-26.76	H
12310.00	*					74.00		H
14772.00	*					74.00		H
17234.00	*					74.00		H
Average Value								
Frequency (MHz)	Read Level (dBuV)	Antenna Factor (dB/m)	Cable Loss (dB)	Preamp Factor (dB)	Level (dBuV/m)	Limit (dBuV/m)	Over Limit (dB)	Pol.
4924.00	35.56	34.57	6.74	34.09	42.78	54.00	-11.22	V
7386.00	24.72	37.29	7.80	34.55	35.26	54.00	-18.74	V
9848.00	25.42	39.55	9.41	34.81	39.57	54.00	-14.43	V
12310.00	*					54.00		V
14772.00	*					54.00		V
17234.00	*					54.00		V
4924.00	34.34	34.57	6.74	34.09	41.56	54.00	-12.44	H
7386.00	23.12	37.29	7.80	34.55	33.66	54.00	-20.34	H
9848.00	22.35	39.55	9.41	34.81	36.50	54.00	-17.50	H
12310.00	*					54.00		H
14772.00	*					54.00		H
17234.00	*					54.00		H

Remark:

1. During the test, pre-scan the 802.11b,g,n(HT20N) mode, and found the 802.11b mode is worse case , the report only record this mode.
2. Level =Receiver Read level + Antenna Factor + Cable Loss – Preamplifier Factor
3. “\*”, means this data is the too weak instrument of signal is unable to test.



**Radiated Band Edge:**

Test Mode: 802.11b Mode					Test channel: Lowest			
Peak Value								
Frequency (MHz)	Read Level (dBuV)	Antenna Factor (dB/m)	Cable Loss (dB)	Preamp Factor (dB)	Level (dBuV/m)	Limit (dBuV/m)	Over Limit (dB)	Pol.
2390.00	52.17	29.15	3.41	34.01	50.72	74.00	-23.28	H
2400.00	61.36	29.16	3.43	34.01	59.94	74.00	-14.06	H
2390.00	53.89	29.15	3.41	34.01	52.44	74.00	-21.56	V
2400.00	63.30	29.16	3.43	34.01	61.88	74.00	-12.12	V
Average Value								
Frequency (MHz)	Read Level (dBuV)	Antenna Factor (dB/m)	Cable Loss (dB)	Preamp Factor (dB)	Level (dBuV/m)	Limit (dBuV/m)	Over Limit (dB)	Pol.
2390.00	38.78	29.15	3.41	34.01	37.33	54.00	-16.67	H
2400.00	47.13	29.16	3.43	34.01	45.71	54.00	-8.29	H
2390.00	40.64	29.15	3.41	34.01	39.19	54.00	-14.81	V
2400.00	48.30	29.16	3.43	34.01	46.88	54.00	-7.12	V

Test Mode: 802.11b Mode					Test channel: Highest			
Peak Value								
Frequency (MHz)	Read Level (dBuV)	Antenna Factor (dB/m)	Cable Loss (dB)	Preamp Factor (dB)	Level (dBuV/m)	Limit (dBuV/m)	Over Limit (dB)	Pol.
2483.50	53.05	29.28	3.53	34.03	51.83	74.00	-22.17	H
2500.00	48.71	29.30	3.56	34.03	47.54	74.00	-26.46	H
2483.50	55.42	29.28	3.53	34.03	54.20	74.00	-19.80	V
2500.00	51.32	29.30	3.56	34.03	50.15	74.00	-23.85	V
Average Value								
Frequency (MHz)	Read Level (dBuV)	Antenna Factor (dB/m)	Cable Loss (dB)	Preamp Factor (dB)	Level (dBuV/m)	Limit (dBuV/m)	Over Limit (dB)	Pol.
2483.50	39.22	29.28	3.53	34.03	38.00	54.00	-16.00	H
2500.00	35.23	29.30	3.56	34.03	34.06	54.00	-19.94	H
2483.50	41.22	29.28	3.53	34.03	40.00	54.00	-14.00	V
2500.00	37.13	29.30	3.56	34.03	35.96	54.00	-18.04	V

Remark:

- Level = Receiver Read level + Antenna Factor + Cable Loss – Preamplifier Factor

**Radiated Band Edge:**

Test Mode: 802.11g Mode					Test channel: Lowest			
Peak Value								
Frequency (MHz)	Read Level (dBuV)	Antenna Factor (dB/m)	Cable Loss (dB)	Preamp Factor (dB)	Level (dBuV/m)	Limit (dBuV/m)	Over Limit (dB)	Pol.
2390.00	51.23	27.53	5.47	33.92	50.31	74.00	-23.69	H
2400.00	60.10	27.55	5.49	29.93	63.21	74.00	-10.79	H
2390.00	52.88	27.53	5.47	33.92	51.96	74.00	-22.04	V
2400.00	61.79	27.55	5.49	29.93	64.90	74.00	-9.10	V
Average Value								
Frequency (MHz)	Read Level (dBuV)	Antenna Factor (dB/m)	Cable Loss (dB)	Preamp Factor (dB)	Level (dBuV/m)	Limit (dBuV/m)	Over Limit (dB)	Pol.
2390.00	38.11	27.53	5.47	33.92	37.19	54.00	-16.81	H
2400.00	46.36	27.55	5.49	29.93	49.47	54.00	-4.53	H
2390.00	39.90	27.53	5.47	33.92	38.98	54.00	-15.02	V
2400.00	47.45	27.55	5.49	29.93	50.56	54.00	-3.44	V

Test Mode: 802.11g Mode					Test channel: Highest			
Peak Value								
Frequency (MHz)	Read Level (dBuV)	Antenna Factor (dB/m)	Cable Loss (dB)	Preamp Factor (dB)	Level (dBuV/m)	Limit (dBuV/m)	Over Limit (dB)	Pol.
2483.50	51.71	29.28	3.53	34.03	50.49	74.00	-23.51	H
2500.00	47.67	29.30	3.56	34.03	46.50	74.00	-27.50	H
2483.50	53.88	29.28	3.53	34.03	52.66	74.00	-21.34	V
2500.00	50.10	29.30	3.56	34.03	48.93	74.00	-25.07	V
Average Value								
Frequency (MHz)	Read Level (dBuV)	Antenna Factor (dB/m)	Cable Loss (dB)	Preamp Factor (dB)	Level (dBuV/m)	Limit (dBuV/m)	Over Limit (dB)	Pol.
2483.50	38.41	29.28	3.53	34.03	37.19	54.00	-16.81	H
2500.00	34.60	29.30	3.56	34.03	33.43	54.00	-20.57	H
2483.50	40.32	29.28	3.53	34.03	39.10	54.00	-14.90	V
2500.00	36.46	29.30	3.56	34.03	35.29	54.00	-18.71	V

Remark:

1. Level = Receiver Read level + Antenna Factor + Cable Loss – Preamplifier Factor

**Radiated Band Edge:**

Test Mode: 802.11n20 Mode					Test channel: Lowest			
Peak Value								
Frequency (MHz)	Read Level (dBuV)	Antenna Factor (dB/m)	Cable Loss (dB)	Preamp Factor (dB)	Level (dBuV/m)	Limit (dBuV/m)	Over Limit (dB)	Pol.
2390.00	50.78	27.53	5.47	33.92	49.86	74.00	-24.14	H
2400.00	59.50	27.55	5.49	29.93	62.61	74.00	-11.39	H
2390.00	52.40	27.53	5.47	33.92	51.48	74.00	-22.52	V
2400.00	61.06	27.55	5.49	29.93	64.17	74.00	-9.83	V
Average Value								
Frequency (MHz)	Read Level (dBuV)	Antenna Factor (dB/m)	Cable Loss (dB)	Preamp Factor (dB)	Level (dBuV/m)	Limit (dBuV/m)	Over Limit (dB)	Pol.
2390.00	37.79	27.53	5.47	33.92	36.87	54.00	-17.13	H
2400.00	45.99	27.55	5.49	29.93	49.10	54.00	-4.90	H
2390.00	39.54	27.53	5.47	33.92	38.62	54.00	-15.38	V
2400.00	47.05	27.55	5.49	29.93	50.16	54.00	-3.84	V

Test Mode: 802.11n20 Mode					Test channel: Highest			
Peak Value								
Frequency (MHz)	Read Level (dBuV)	Antenna Factor (dB/m)	Cable Loss (dB)	Preamp Factor (dB)	Level (dBuV/m)	Limit (dBuV/m)	Over Limit (dB)	Pol.
2483.50	51.06	29.28	3.53	34.03	49.84	74.00	-24.16	H
2500.00	47.17	29.30	3.56	34.03	46.00	74.00	-28.00	H
2483.50	53.14	29.28	3.53	34.03	51.92	74.00	-22.08	V
2500.00	49.52	29.30	3.56	34.03	48.35	74.00	-25.65	V
Average Value								
Frequency (MHz)	Read Level (dBuV)	Antenna Factor (dB/m)	Cable Loss (dB)	Preamp Factor (dB)	Level (dBuV/m)	Limit (dBuV/m)	Over Limit (dB)	Pol.
2483.50	38.02	29.28	3.53	34.03	36.80	54.00	-17.20	H
2500.00	34.29	29.30	3.56	34.03	33.12	54.00	-20.88	H
2483.50	39.89	29.28	3.53	34.03	38.67	54.00	-15.33	V
2500.00	36.14	29.30	3.56	34.03	34.97	54.00	-19.03	V

Remark:

1. Level = Receiver Read level + Antenna Factor + Cable Loss – Preamplifier Factor

## 5. Maximum Peak Output Power Test

### 5.1. Test Standard and Limit

Test Standard	FCC Part15 C Section 15.247 (b)(3)
Test Limit	30dBm

### 5.2. Test Setup

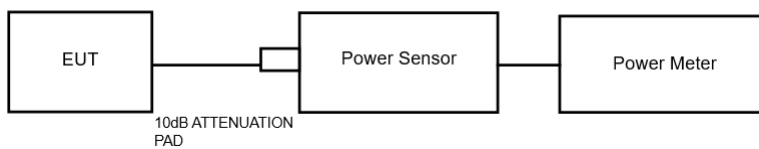

### 5.3. Test Procedure

1. The Transmitter output (antenna port) was connected to the power meter.
2. Turn on the EUT and power meter and then record the power value.
3. Repeat above procedures on all channels needed to be tested.

Note: The cable loss and attenuator loss were offset into measure device as amplitude offset.

### 5.4. Test Data

Test Item	:	Max. peak output power
Test Voltage	:	DC 3.6V Battery inside
Test Result	:	PASS

Test Mode	:	CH Low ~ CH High
Temperature	:	24℃
Humidity	:	55%RH

Test Channel	Frequency (MHz)	Maximum Peak Conducted Output Power (PK) (dBm)	Limit dBm	Results
<b>TX 802.11b Mode</b>				
CH01	2412	12.65	30	PASS
CH06	2437	11.60	30	PASS
CH11	2462	11.17	30	PASS
<b>TX 802.11g Mode</b>				
CH01	2412	12.97	30	PASS
CH06	2437	11.09	30	PASS
CH11	2462	11.10	30	PASS
<b>TX 802.11n(20) Mode</b>				
CH01	2412	12.10	30	PASS
CH06	2437	10.51	30	PASS
CH11	2462	10.11	30	PASS

**Note: For power test the duty cycle is 100% in continuous transmitting mode.**

**Please see the plot of next page**

**Duty Cycle**

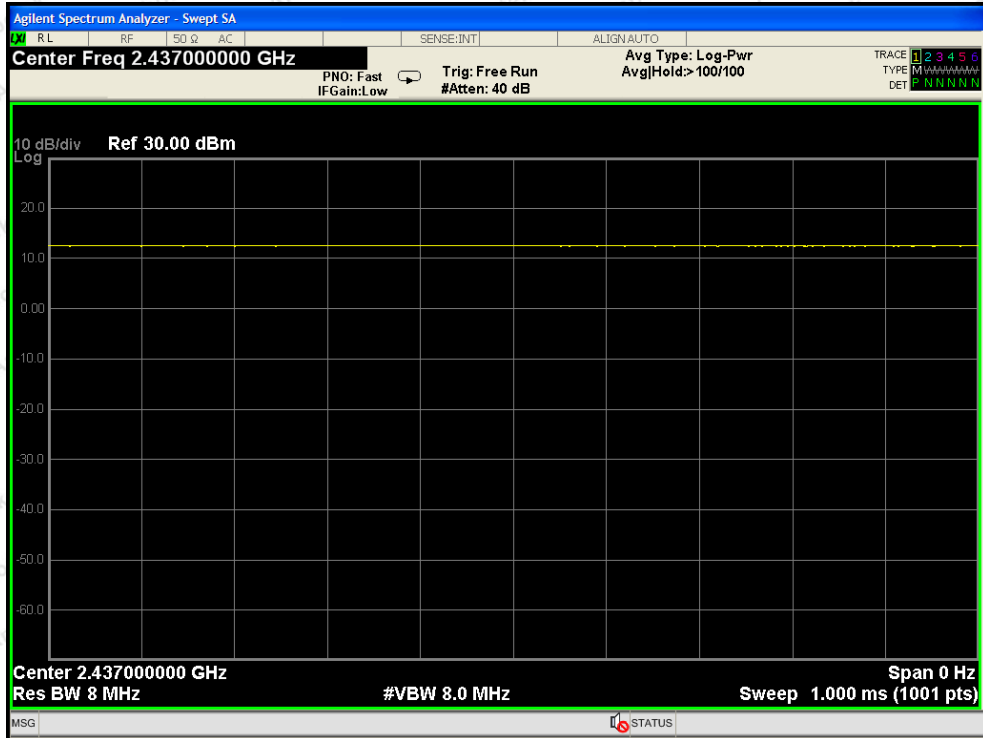

802.11b mode

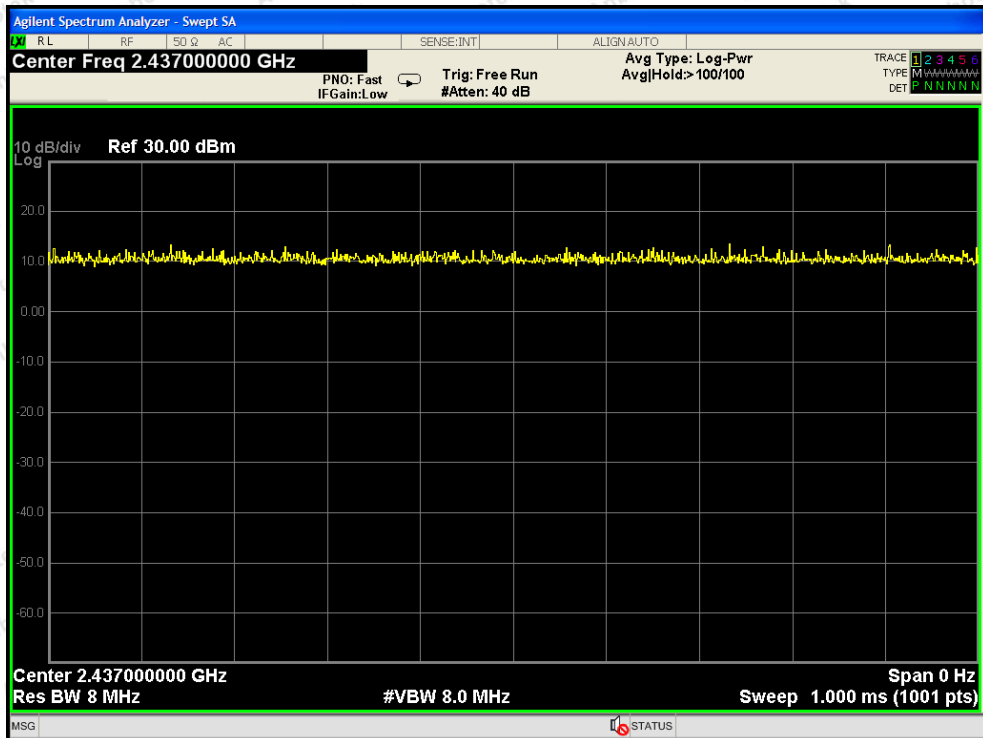

802.11g mode

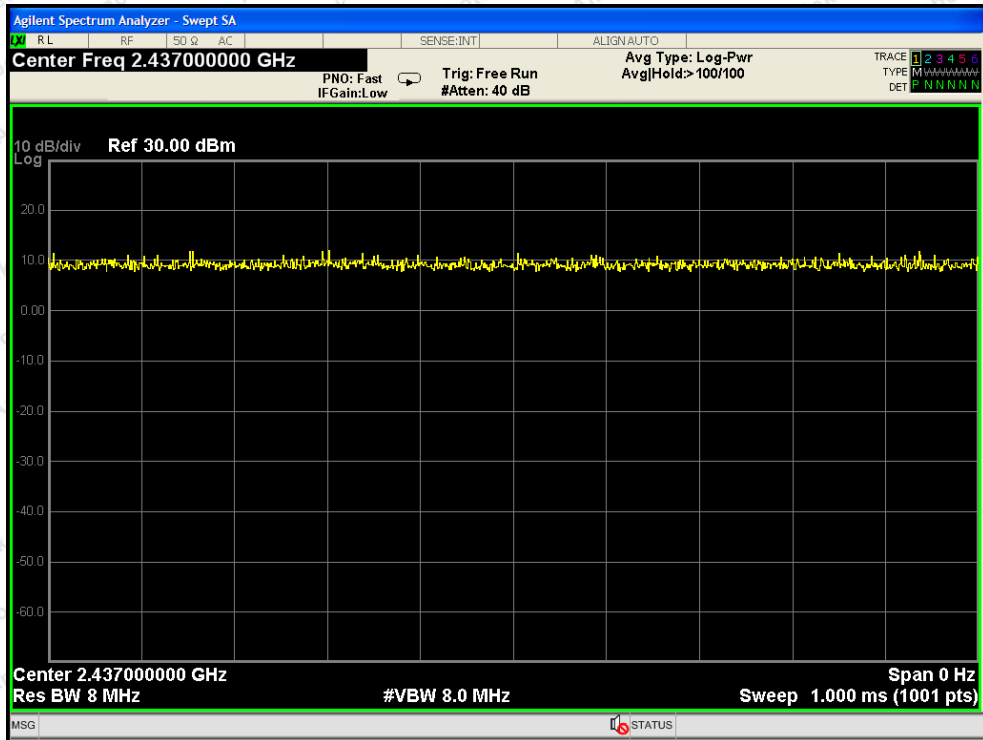

802.11n(HT20) mode

## 6. 6DB Occupy Bandwidth Test

### 6.1. Test Standard and Limit

Test Standard	FCC Part15 C Section 15.247 (a)(2)
Test Limit	>500kHz

### 6.2. Test Setup

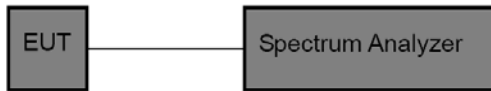

### 6.3. Test Procedure

1. Place the EUT on the table and set it in the transmitting mode.
2. Remove the antenna from the EUT and then connect a low loss RF cable from the antenna port to the spectrum analyzer.
3. Set the spectrum analyzer as:  
 RBW= 100kHz, VBW≥3\*RBW =300kHz  
 Detector= Peak  
 Trace mode= Max hold.  
 Sweep- auto couple.
4. Mark the peak frequency and -6dB (upper and lower) frequency.
5. Repeat until all the rest channels are investigated.

### 6.4. Test Data

Test Item	: 6dB Bandwidth	Test Mode	: CH Low ~ CH High
Test Voltage	: DC 3.6V Battery inside	Temperature	: 24°C
Test Result	: PASS	Humidity	: 55%RH

Mode	Channel	Frequency (MHz)	Bandwidth (MHz)	Limit (kHz)	Results
802.11b	Low	2412	10.10	>500	PASS
	Middle	2437	10.10		PASS
	High	2462	10.10		PASS
802.11g	Low	2412	16.37	>500	PASS
	Middle	2437	16.38		PASS
	High	2462	16.39		PASS
802.11n20	Low	2412	17.62	>500	PASS
	Middle	2437	17.63		PASS
	High	2462	17.60		PASS



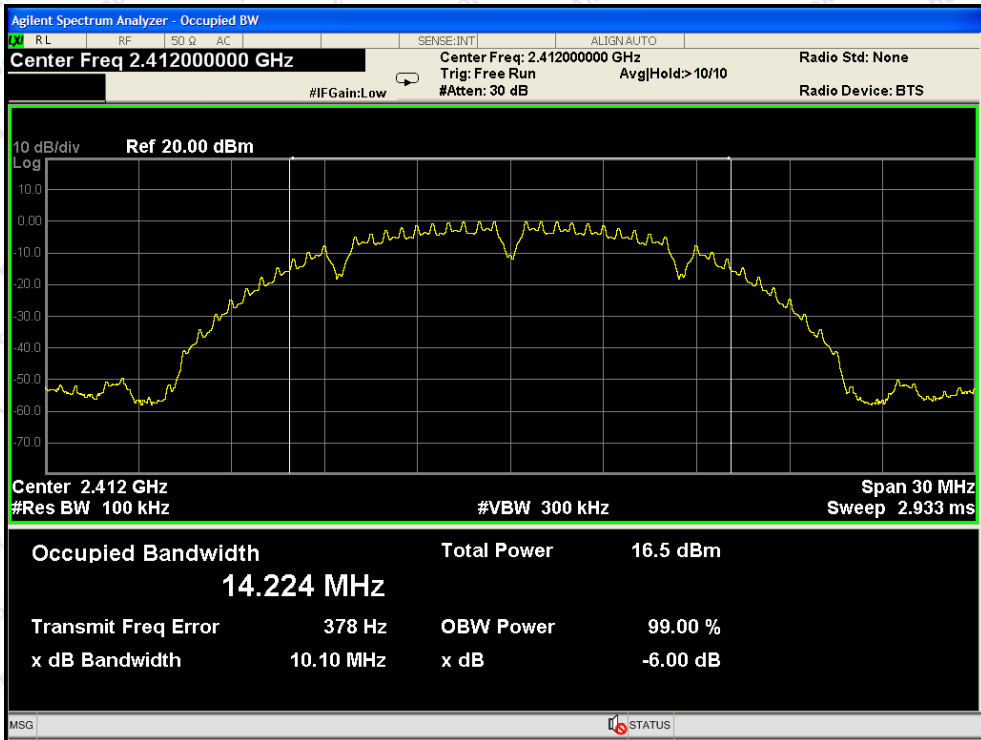

802.11b mode : Lowest

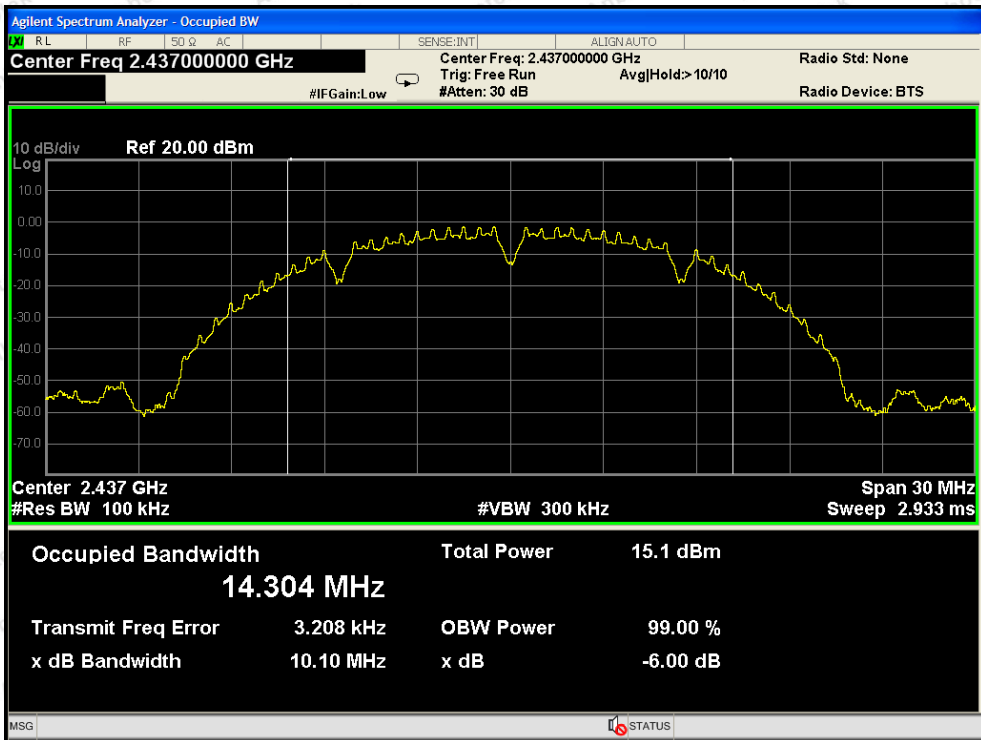

802.11b mode : Middle

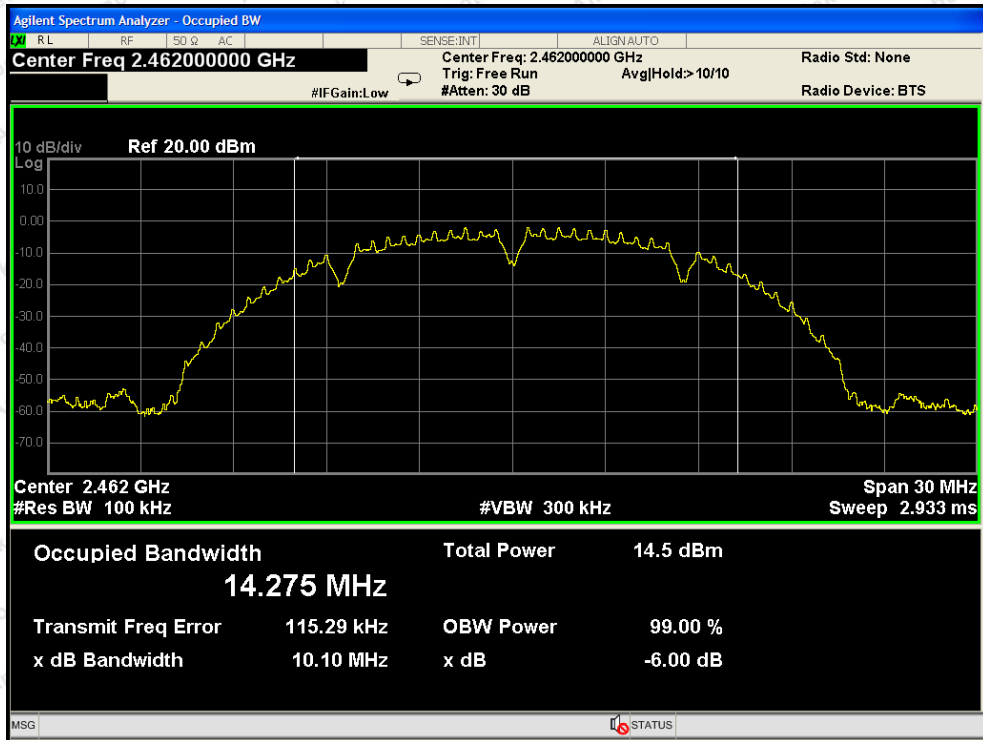

802.11b mode : Highest

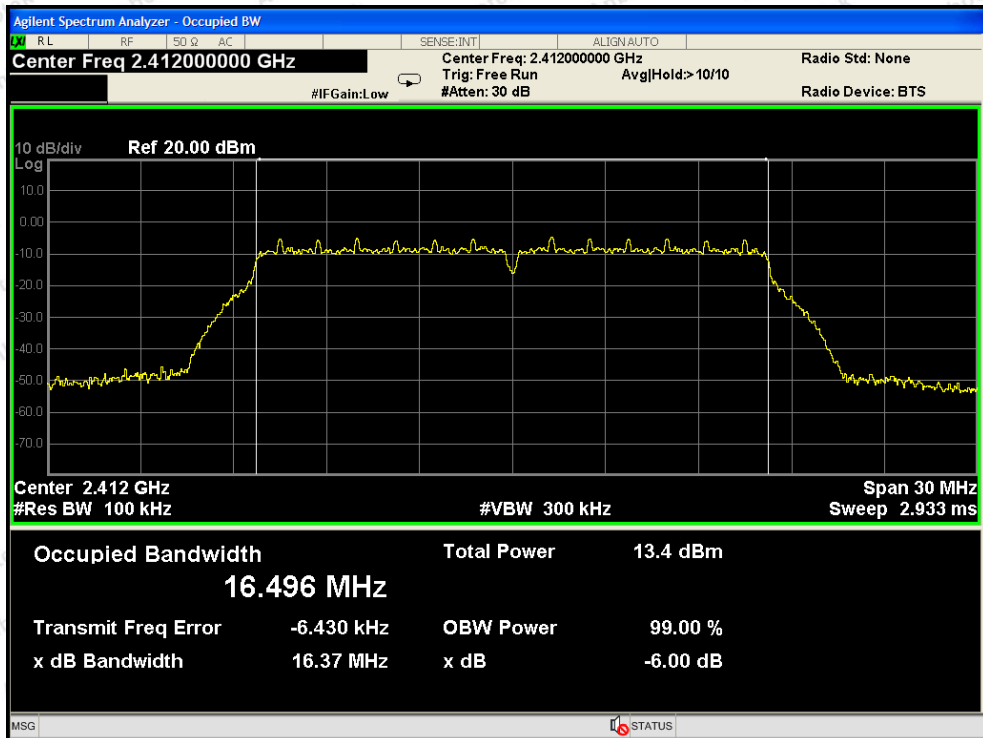

802.11g mode : Lowest

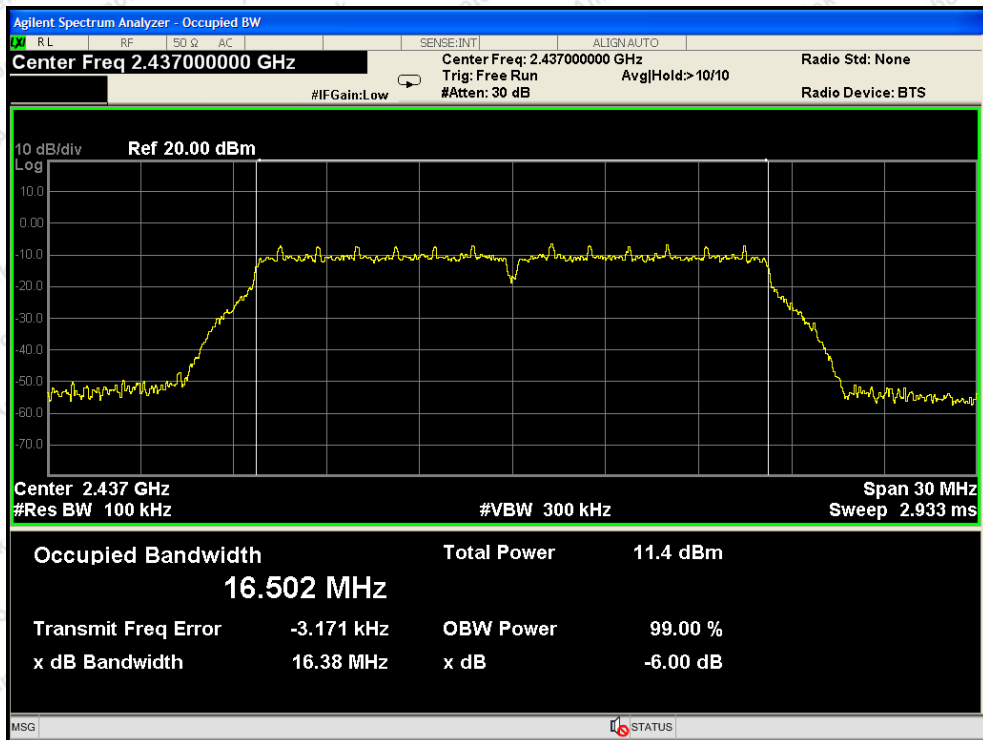

802.11g mode : Middle

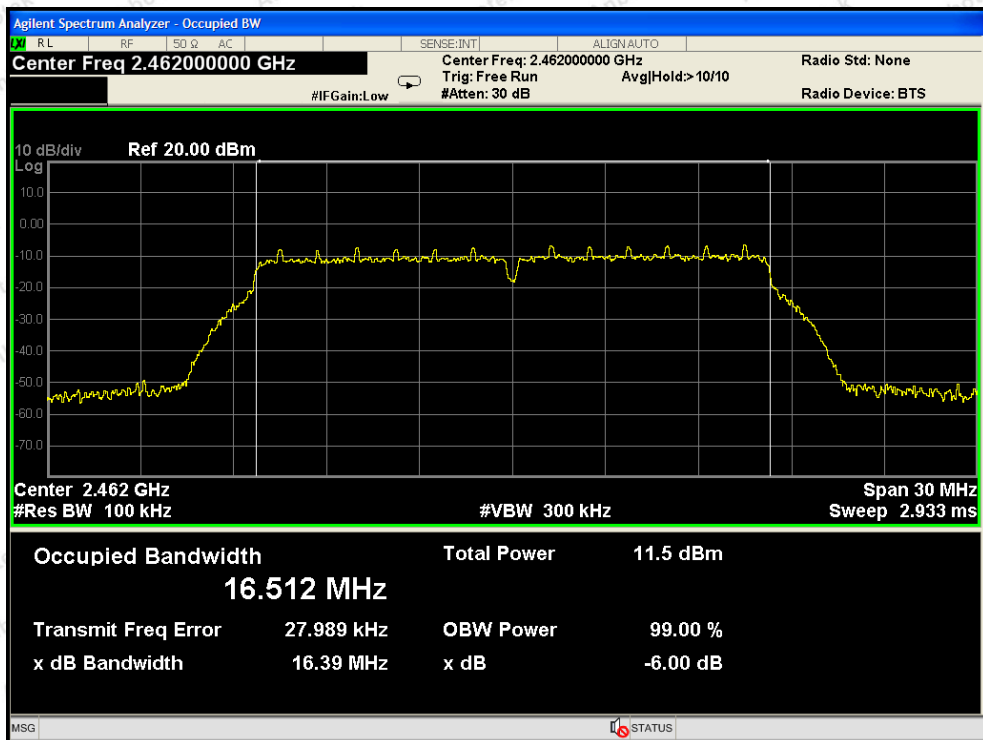

802.11g mode : Highest

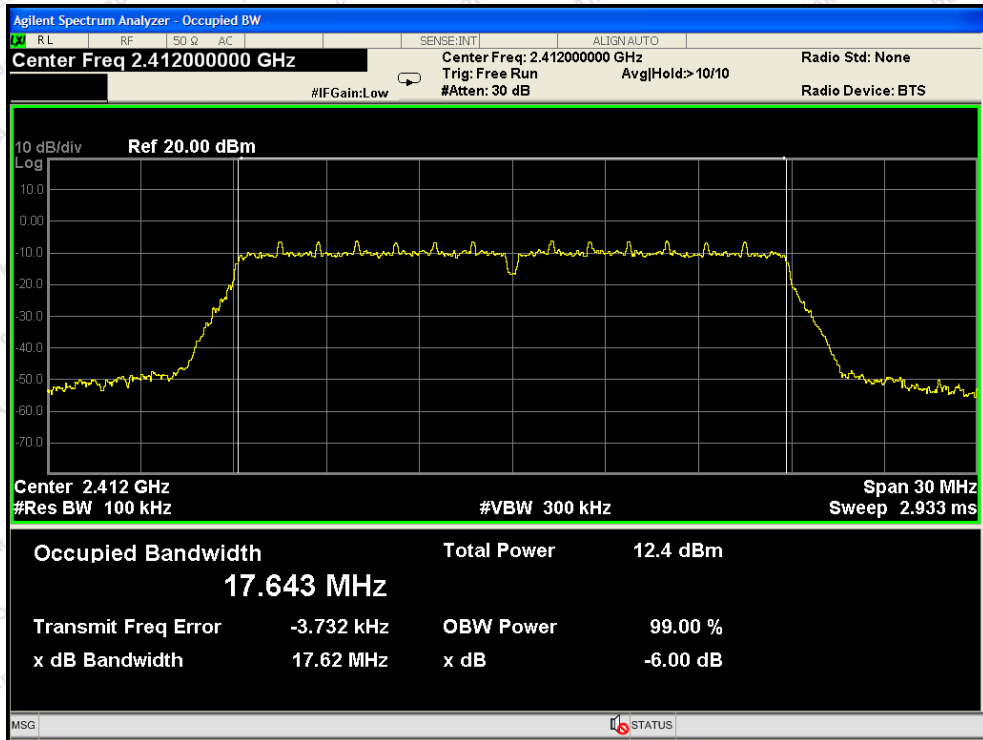

802.11n20 mode : Lowest

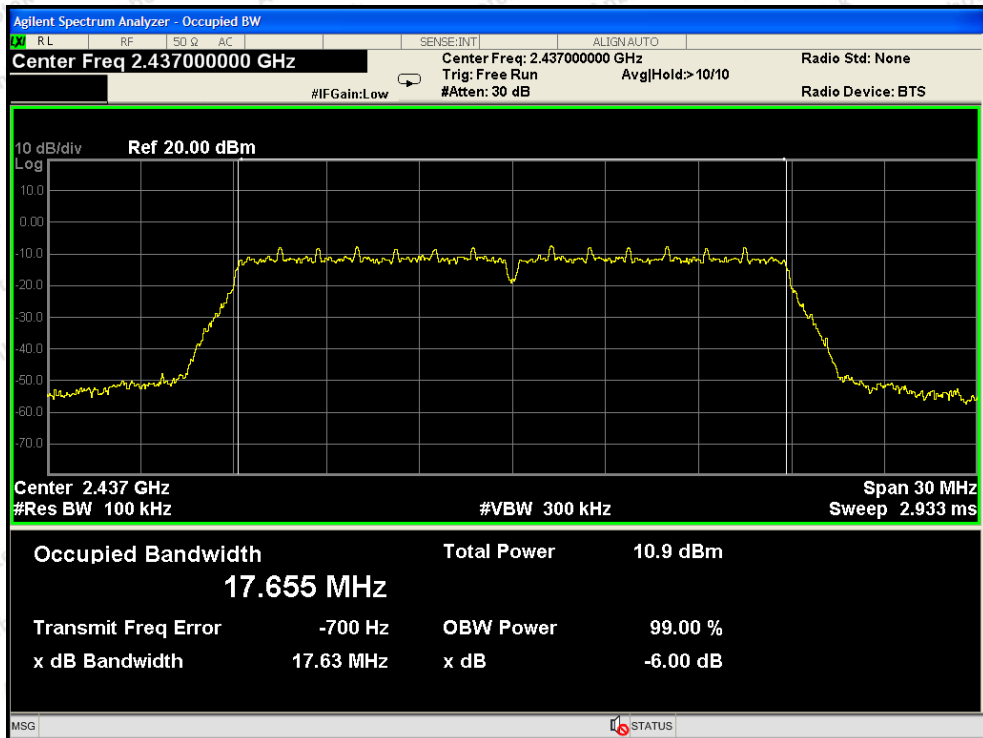

802.11n20 mode : Middle

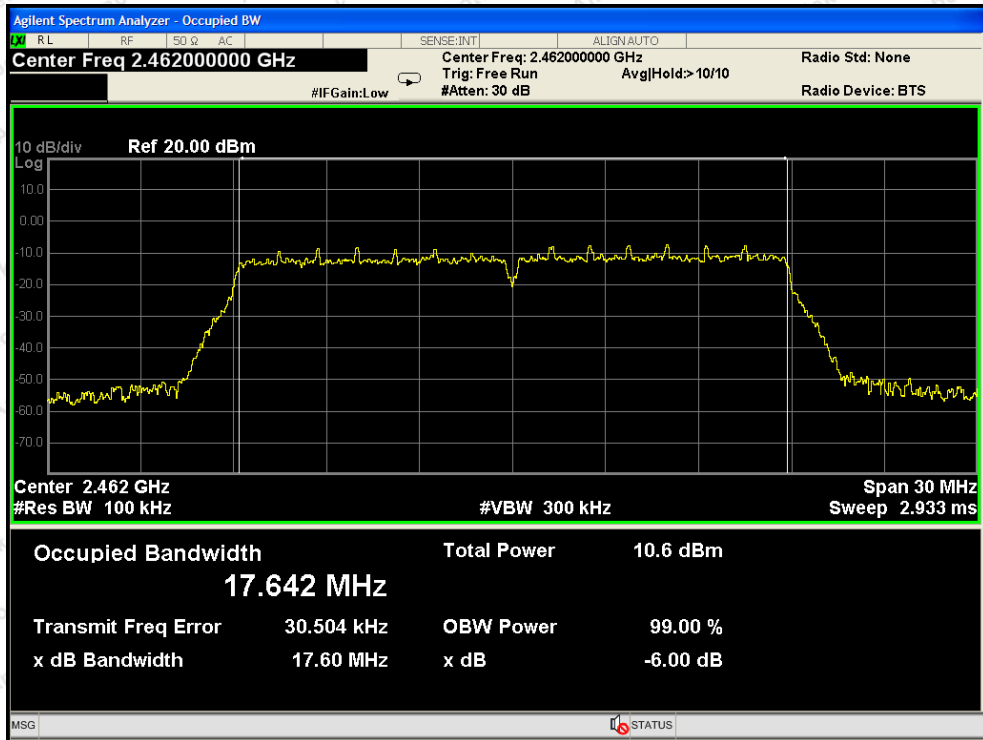

802.11n20 mode : Highest

## 7. Power Spectral Density Test

### 7.1. Test Standard and Limit

Test Standard	FCC Part15 C Section
Test Limit	8dBm/3KHz

### 7.2. Test Setup

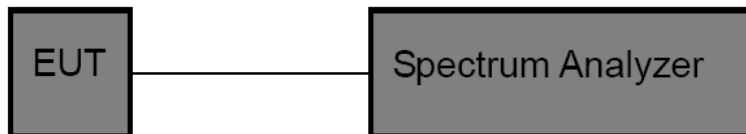

### 7.3. Test Procedure

1. Place the EUT on the table and set it in transmitting mode. Remove the antenna from the EUT and then connect a low loss RF cable from the antenna port to the spectrum analyzer.
2. Set the spectrum analyzer as RBW = 3kHz, VBW = 10kHz, Span = 1.5xDTS BW
3. Record the max. reading.
4. Repeat the above procedure until the measurements for all frequencies are completed.

### 7.4. Test Data

Test Item : Power Spectral Density  
 Test Voltage : DC 3.6V Battery inside  
 Test Result : PASS

Test Mode : CH Low ~ CH High  
 Temperature : 24°C  
 Humidity : 55%RH

Mode	Channel	Frequency (MHz)	PSD (dBm/3KHz)	Limit (dBm/3KHz)	Results
802.11b	Low	2412	-15.455	8.00	PASS
	Middle	2437	-16.456	8.00	PASS
	High	2462	-16.485	8.00	PASS
802.11g	Low	2412	-19.988	8.00	PASS
	Middle	2437	-20.126	8.00	PASS
	High	2462	-21.582	8.00	PASS
802.11n20	Low	2412	-20.584	8.00	PASS
	Middle	2437	-22.120	8.00	PASS
	High	2462	-23.463	8.00	PASS

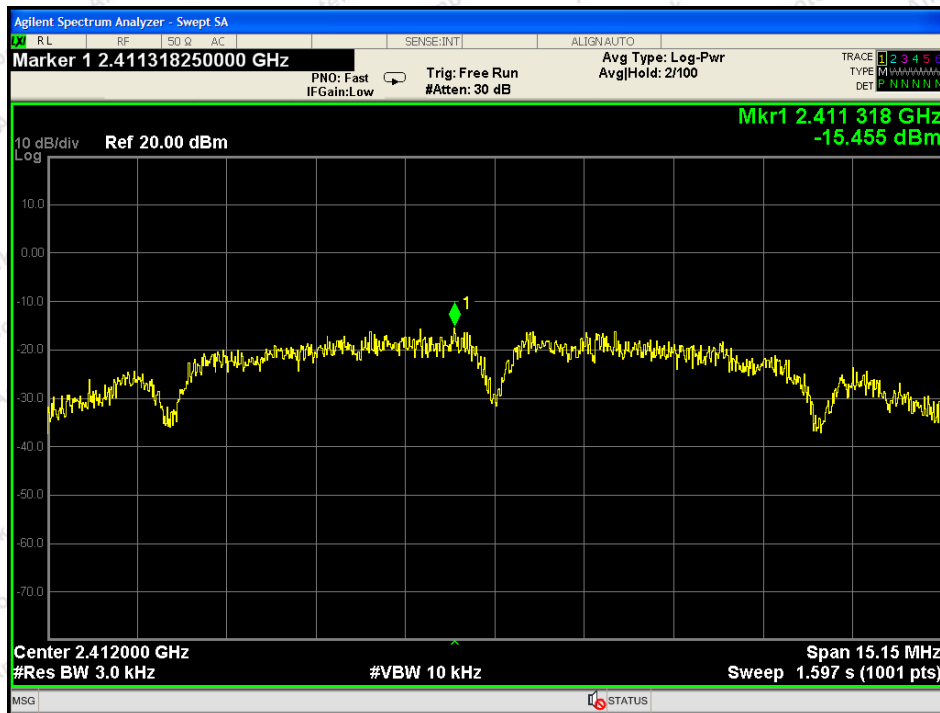

802.11b mode : Lowest

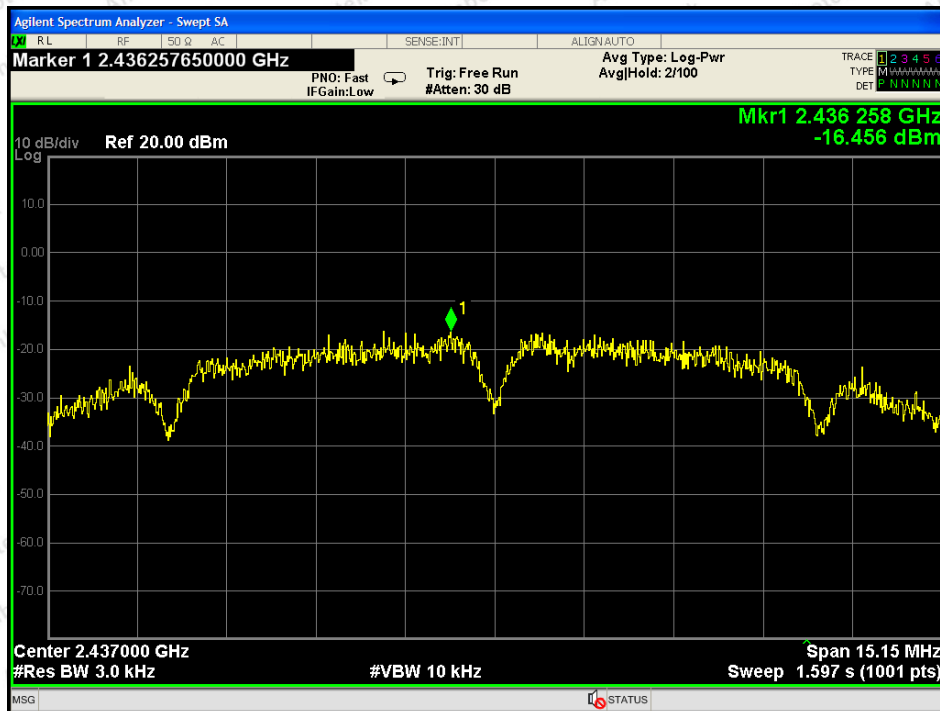

802.11b mode : Middle

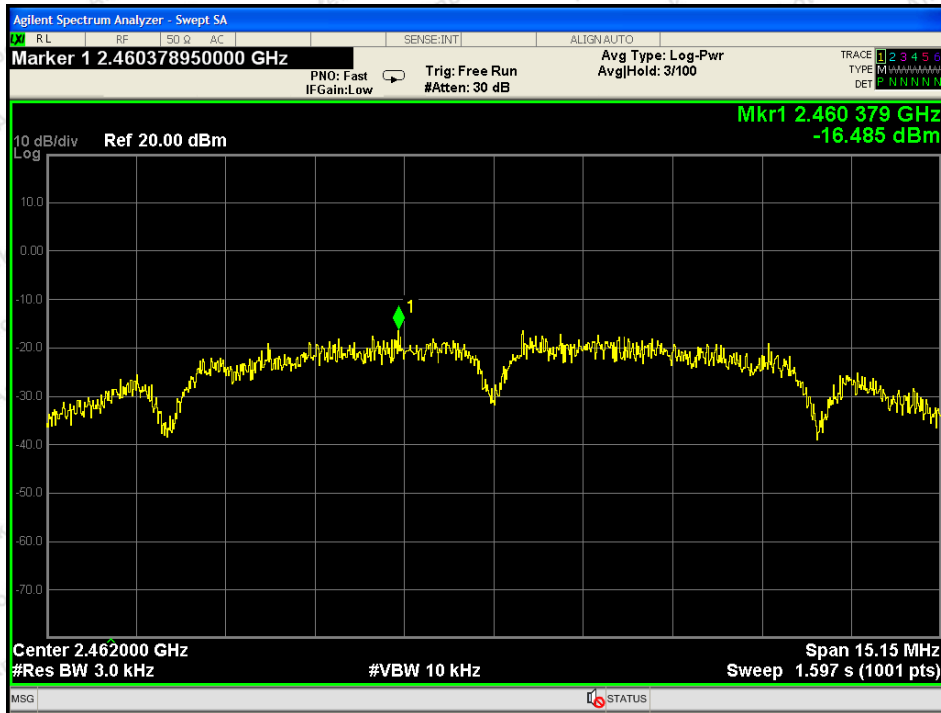

802.11b mode : Highest

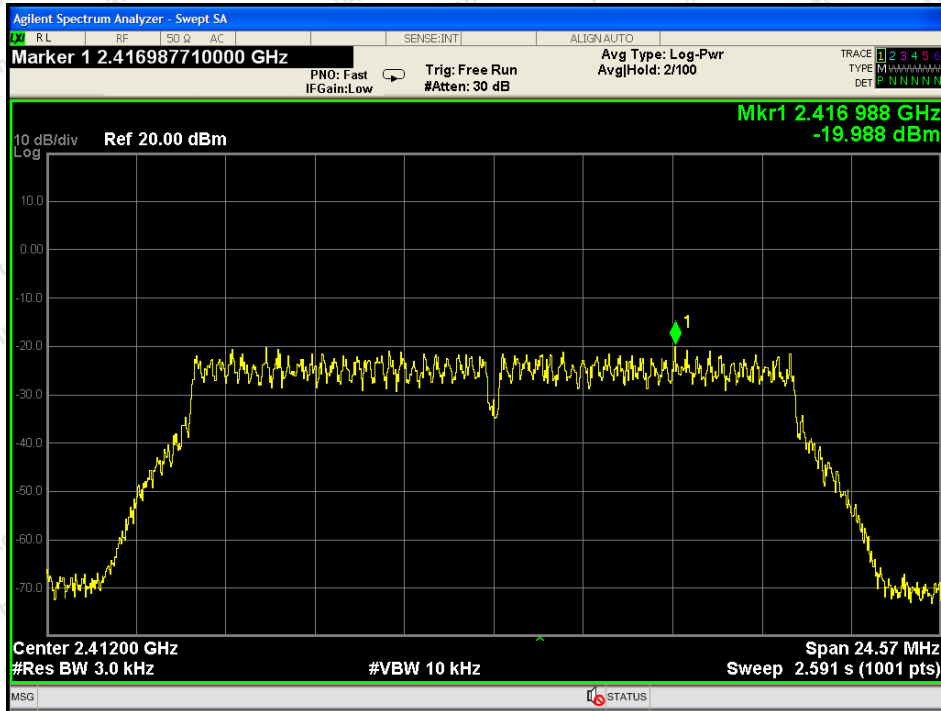

802.11g mode : Lowest



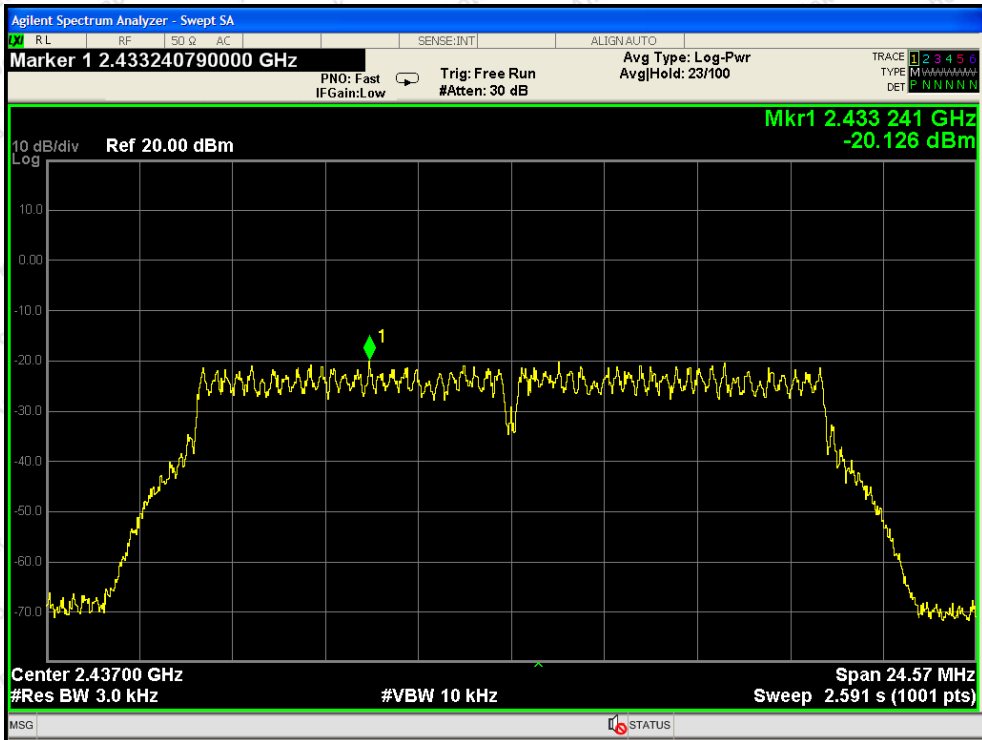

802.11g mode : Middle

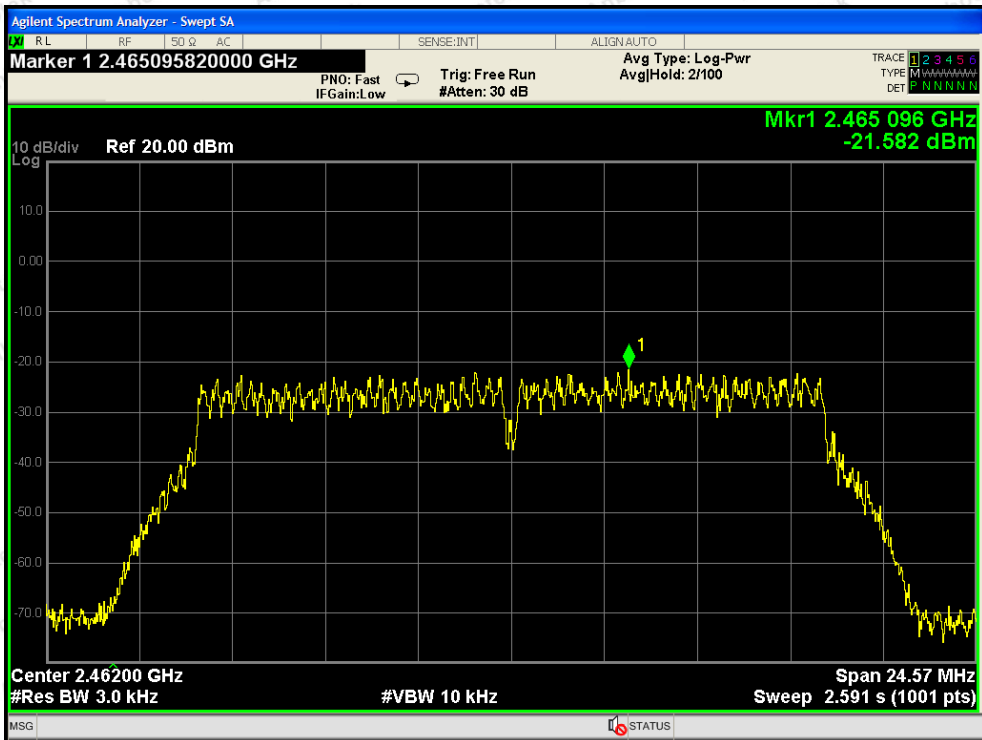

802.11g mode : Highest

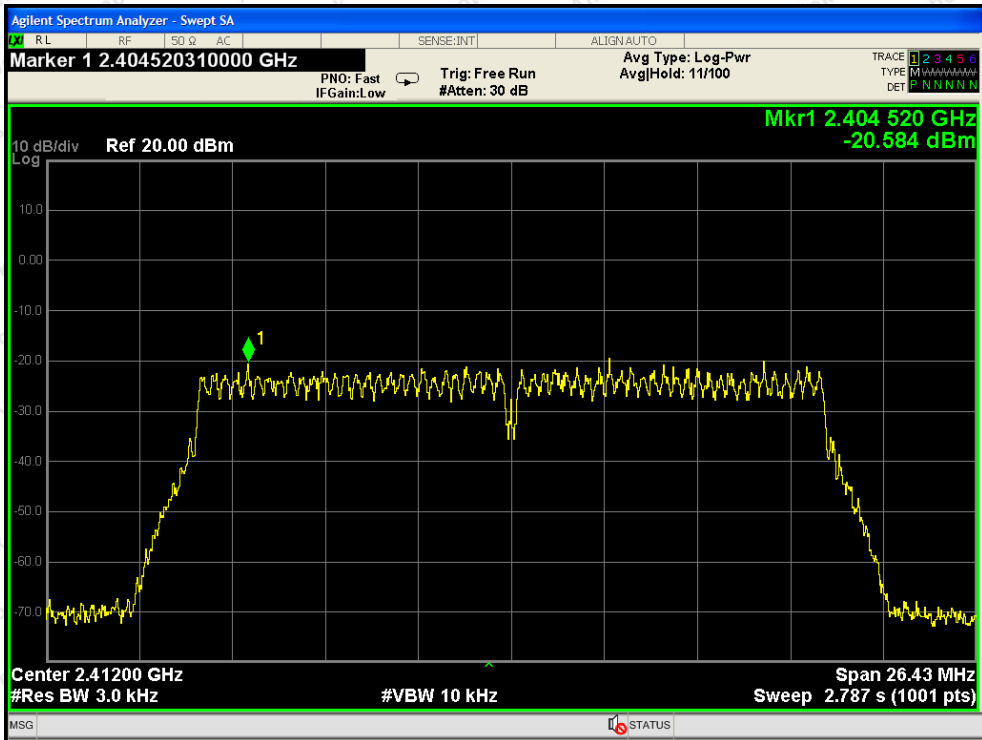

802.11n20 mode : Lowest

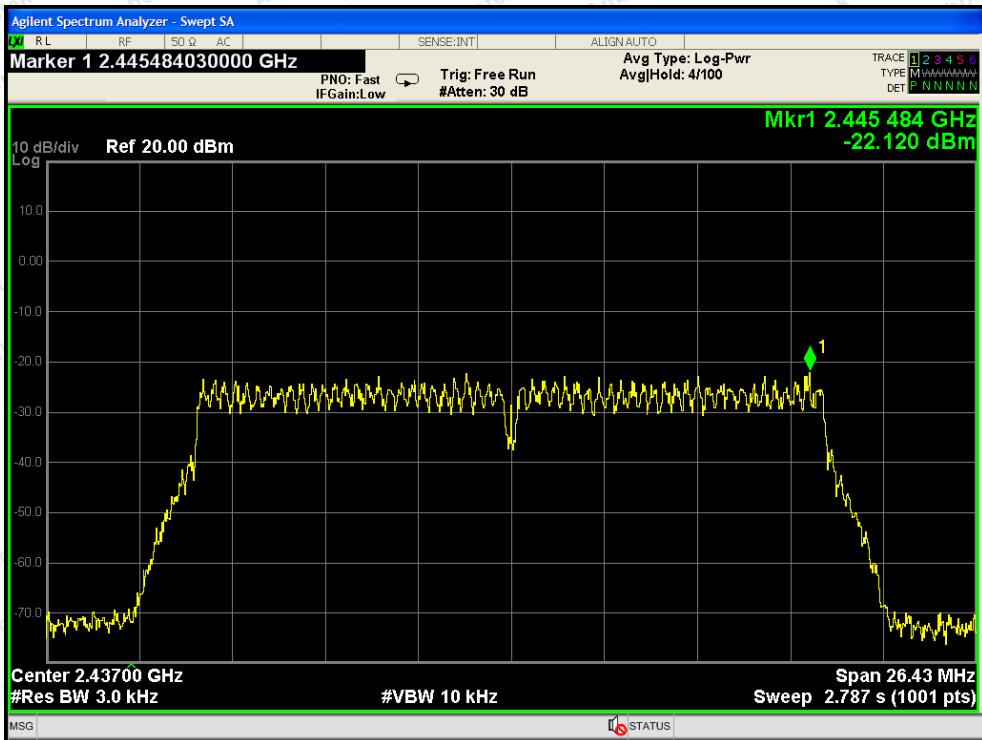

802.11n20 mode : Middle

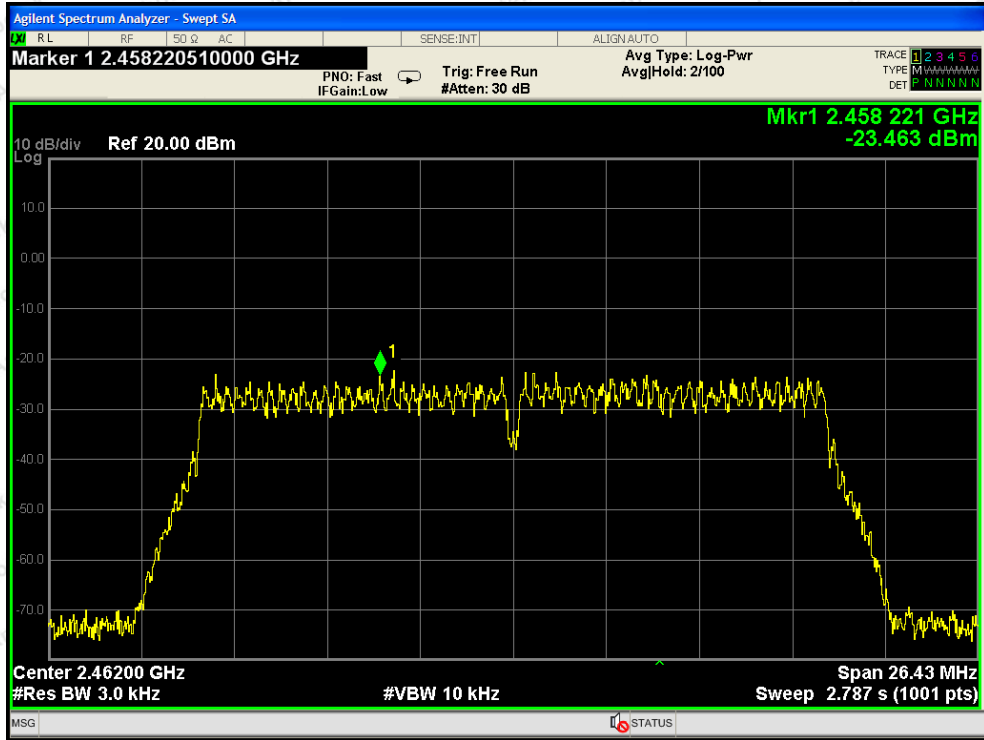

802.11n20 mode : Highest

## 8. 100kHz Bandwidth of Frequency Band Edge Requirement

### 8.1. Test Standard and Limit

Test Standard	FCC Part15 C Section 15.247 (d)
Test Limit	in any 100 kHz bandwidth outside the frequency bands in which the spread spectrum intentional radiator is operating, the radio frequency power that is produced by the intentional radiator shall be at least 20dB below that in the 100kHz bandwidth within the band that contains the highest level of the desired power, In addition, radiated emissions which fall in the restricted bands, as defined in §15.205(a), must also comply with the radiated emission limits specified in 15.209(a).

### 8.2. Test Setup

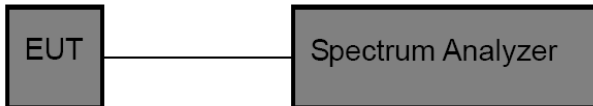

### 8.3. Test Procedure

Using the following spectrum analyzer setting:

1. Set the RBW = 100KHz.
2. Set the VBW = 300KHz.
3. Sweep time = auto couple.
4. Detector function = peak.
5. Trace mode = max hold.
6. Allow trace to fully stabilize.

### 8.4. Test Data

Test Item	:	Band edge
Test Voltage	:	DC 3.6V Battery inside
Test Result	:	PASS

Test Mode	:	CH Low ~ CH High
Temperature	:	24°C
Humidity	:	55%RH

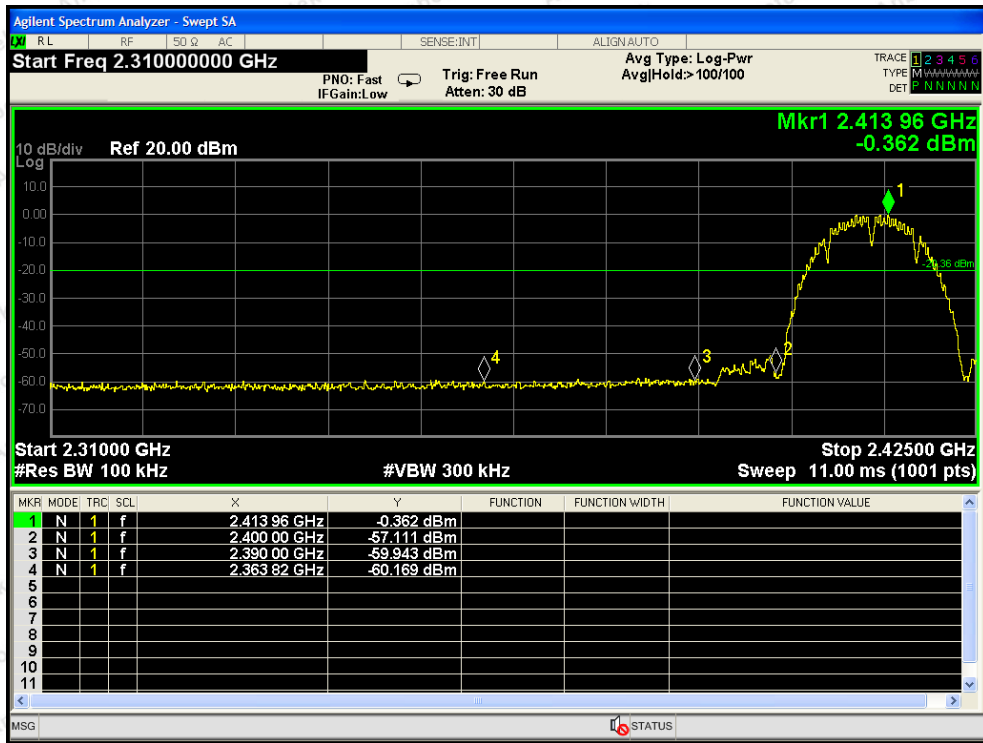

802.11b mode : Lowest

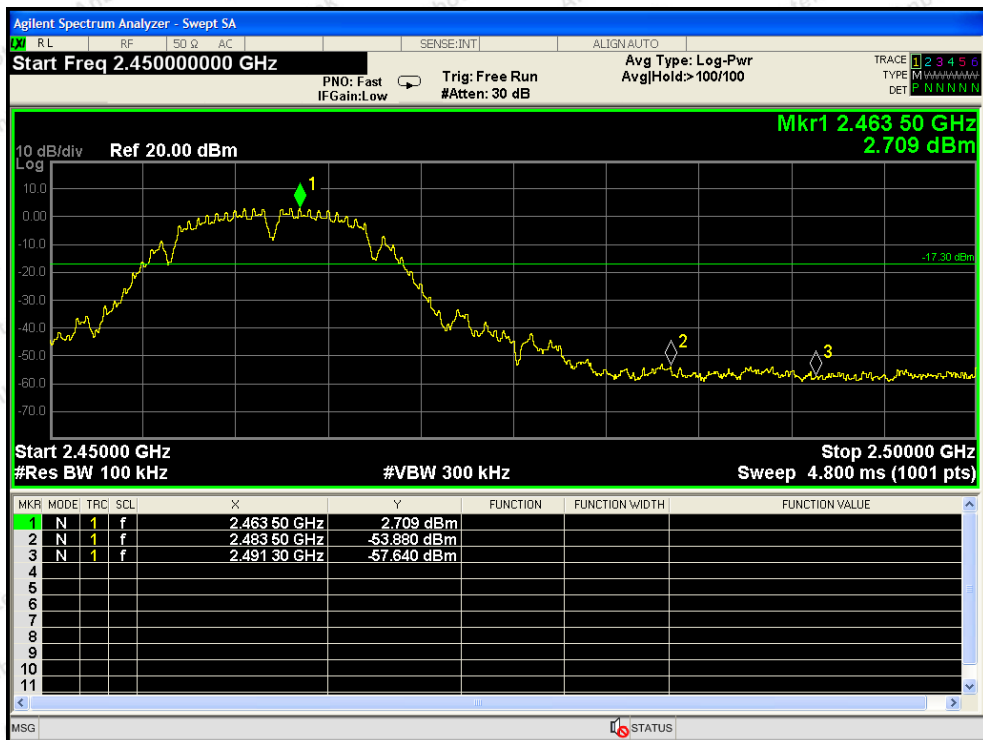

802.11b mode : Highest

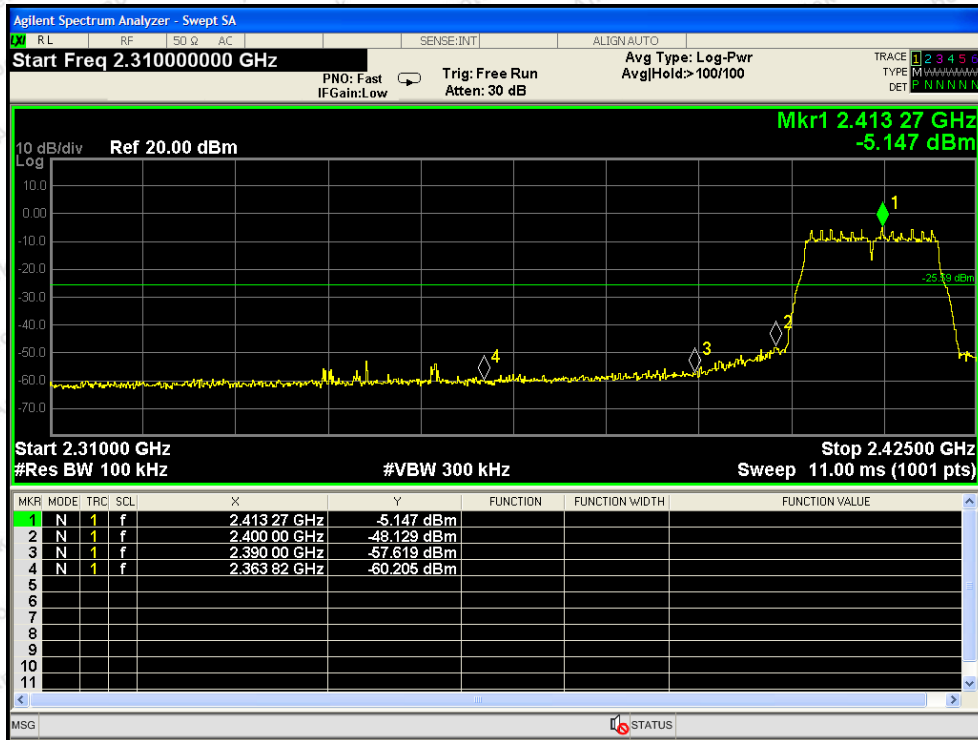

802.11g mode : Lowest

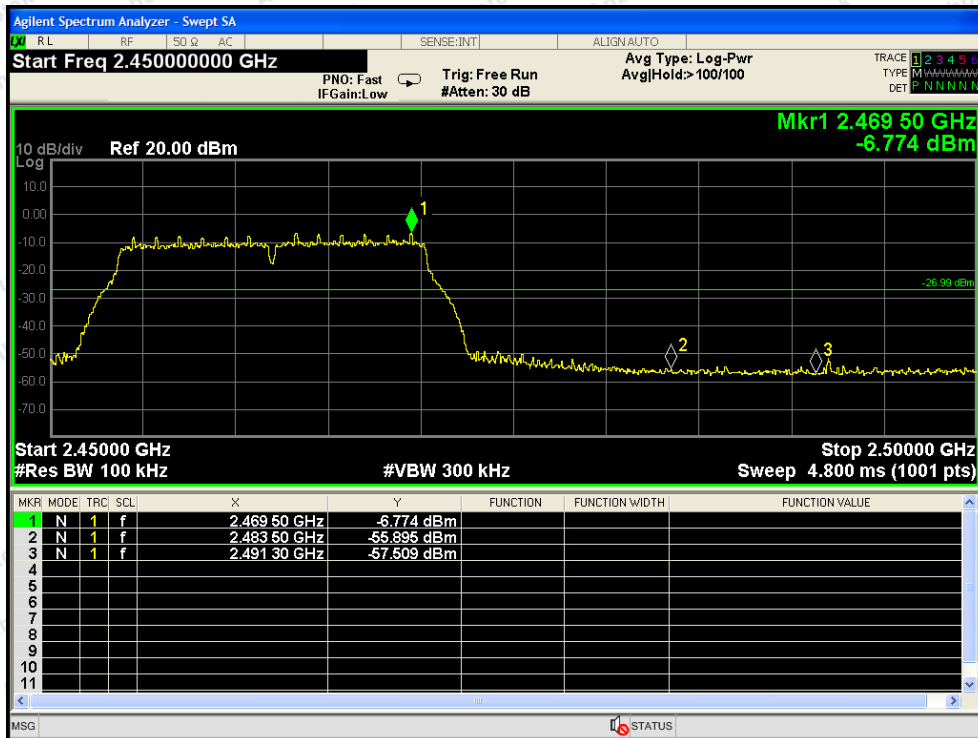

802.11g mode : Highest

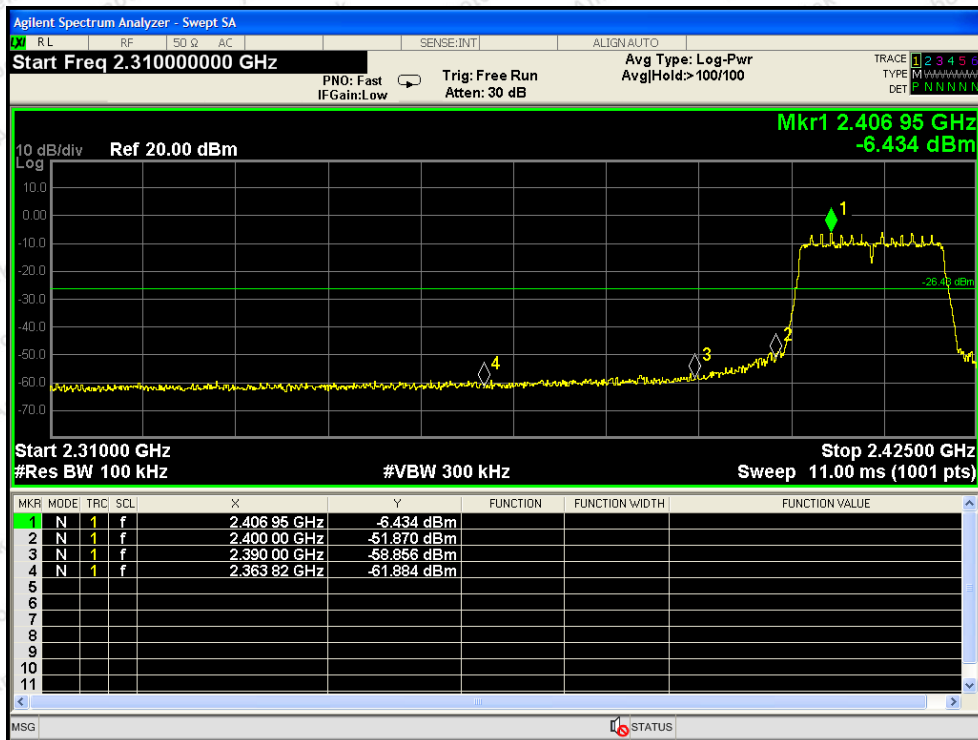

802.11n20 mode : Lowest

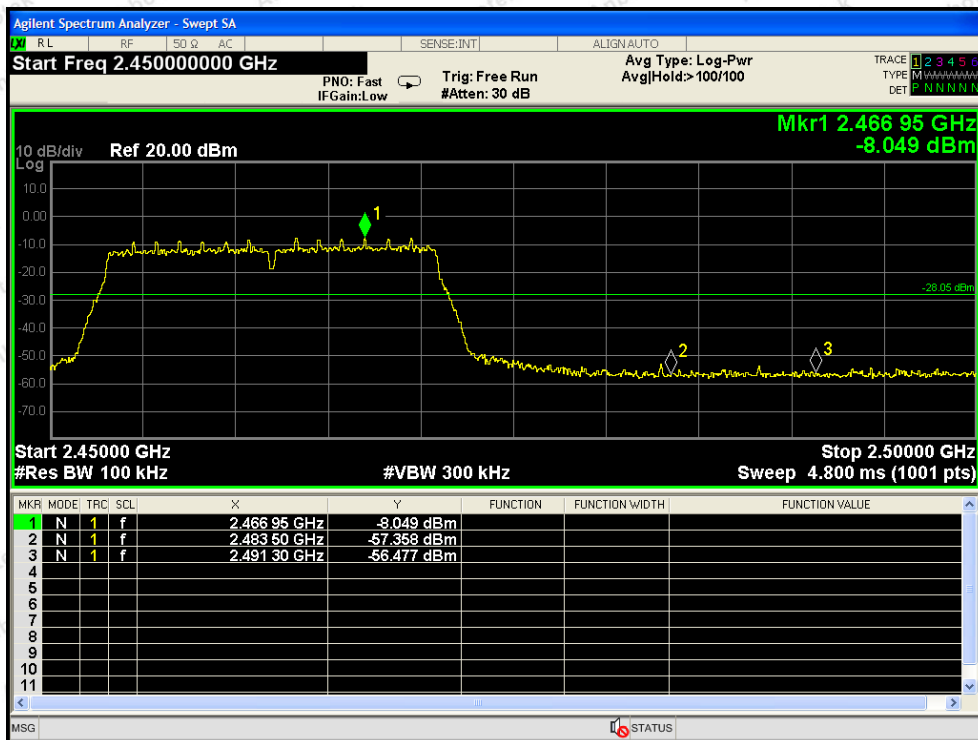

802.11n20 mode : Highest

Conducted Emission Method

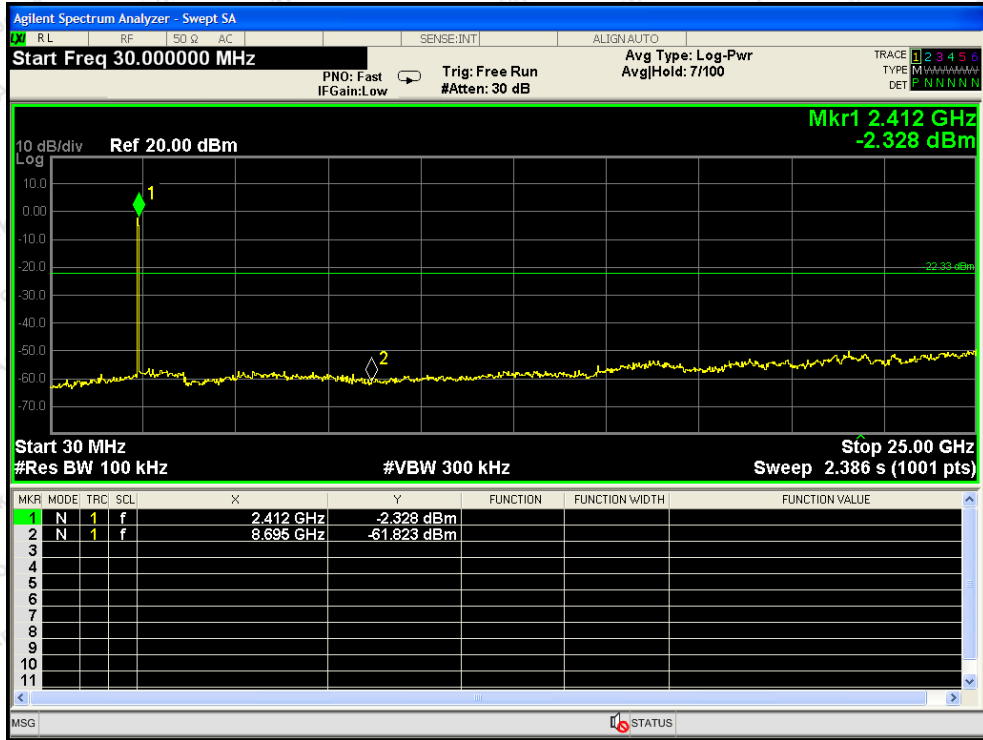

802.11b mode : Lowest

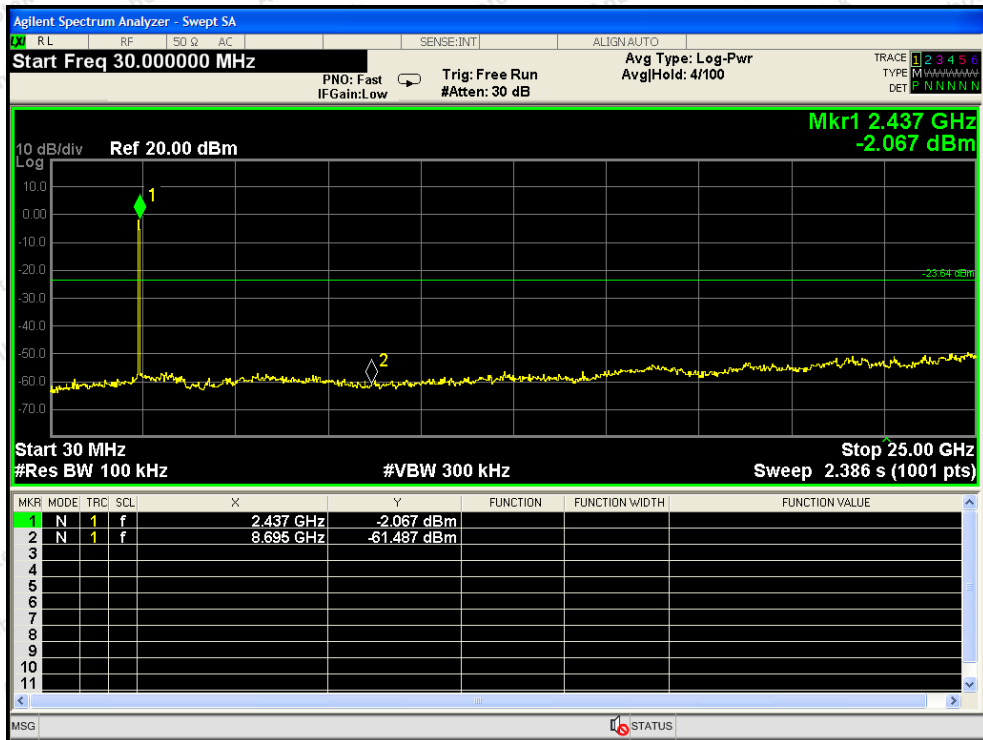

802.11b mode : Middle



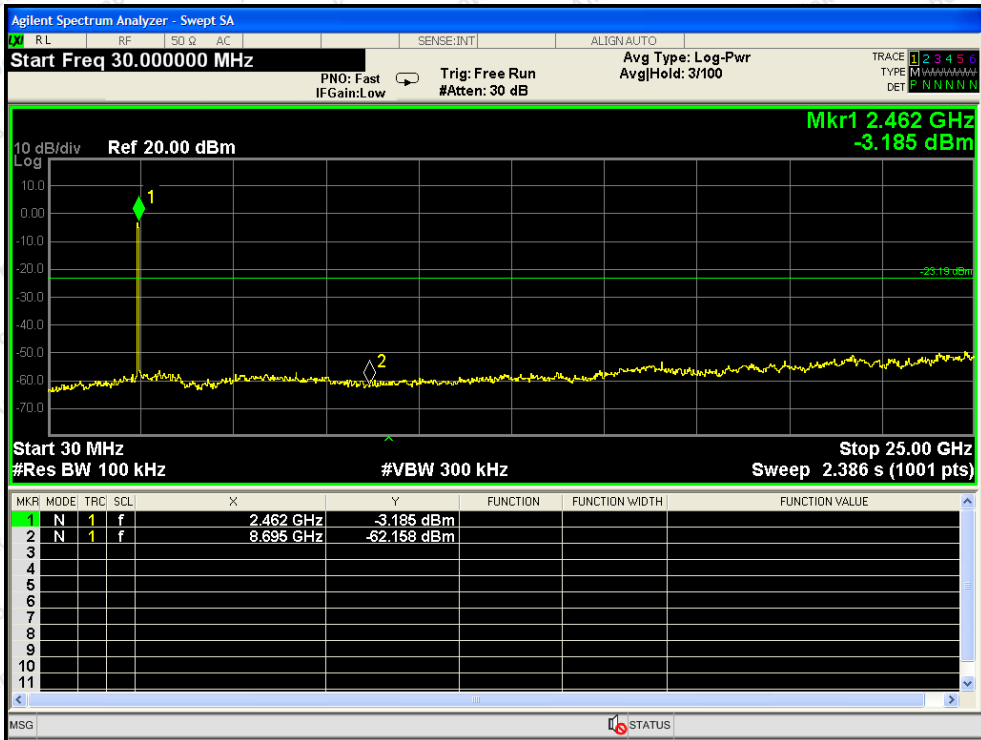

802.11b mode : Highest

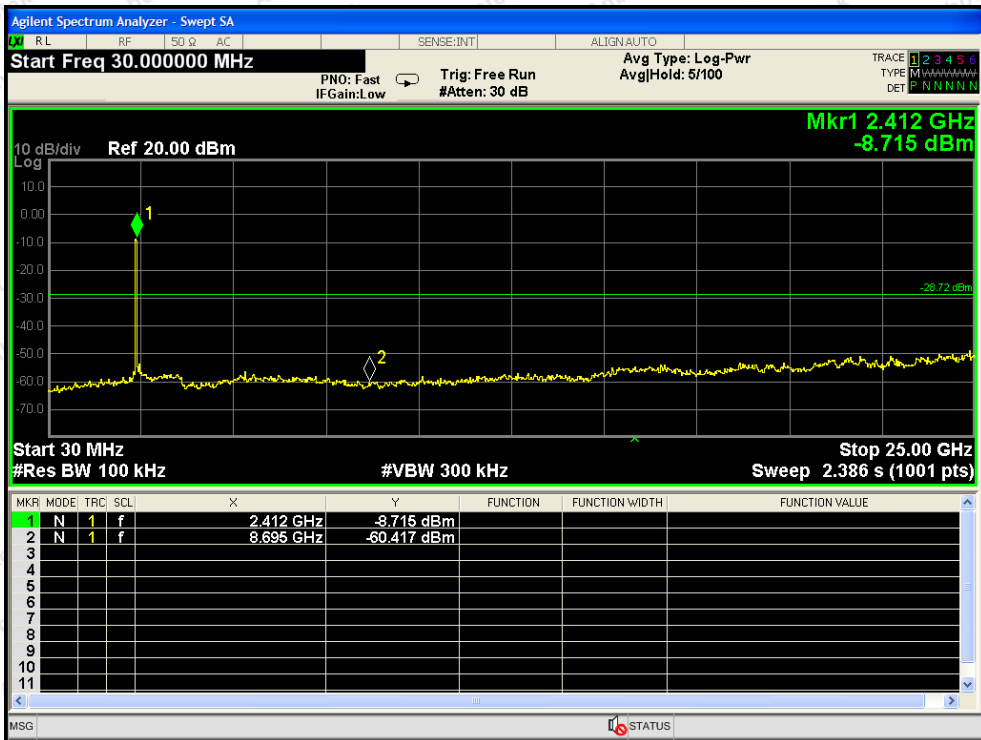

802.11g mode : Lowest

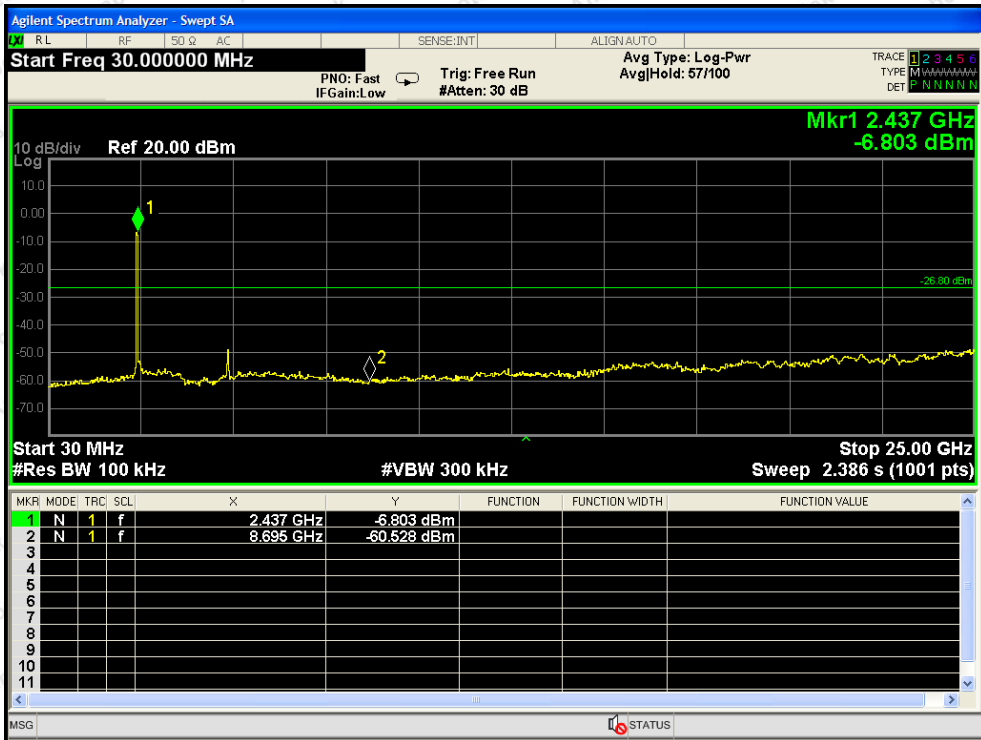

802.11g mode : Middle

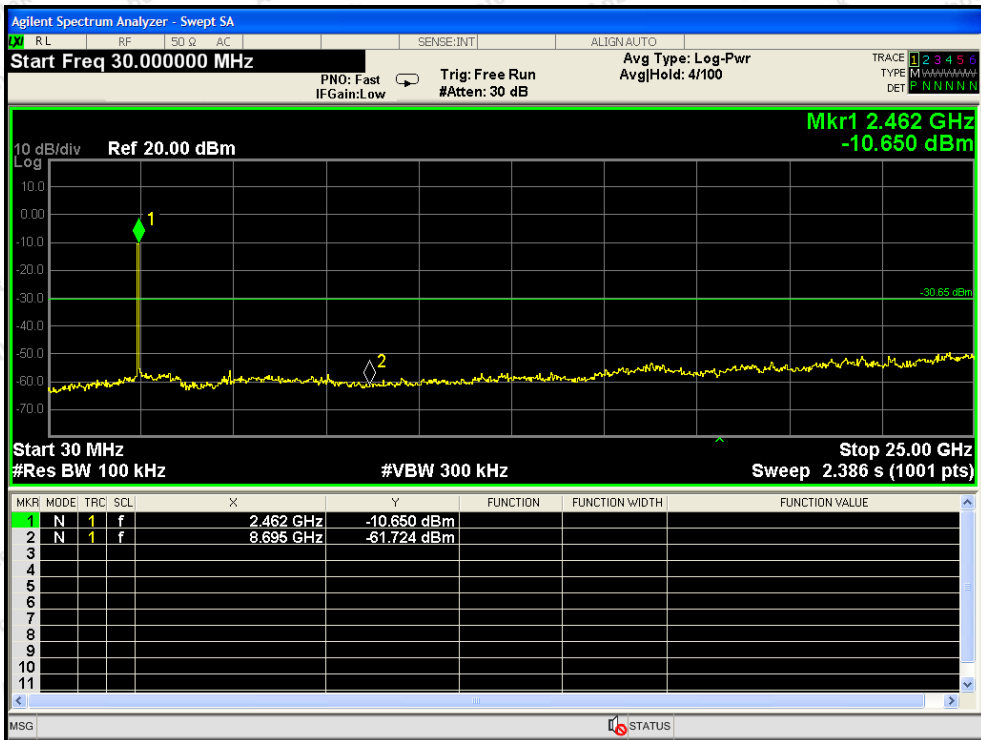

802.11g mode : Highest

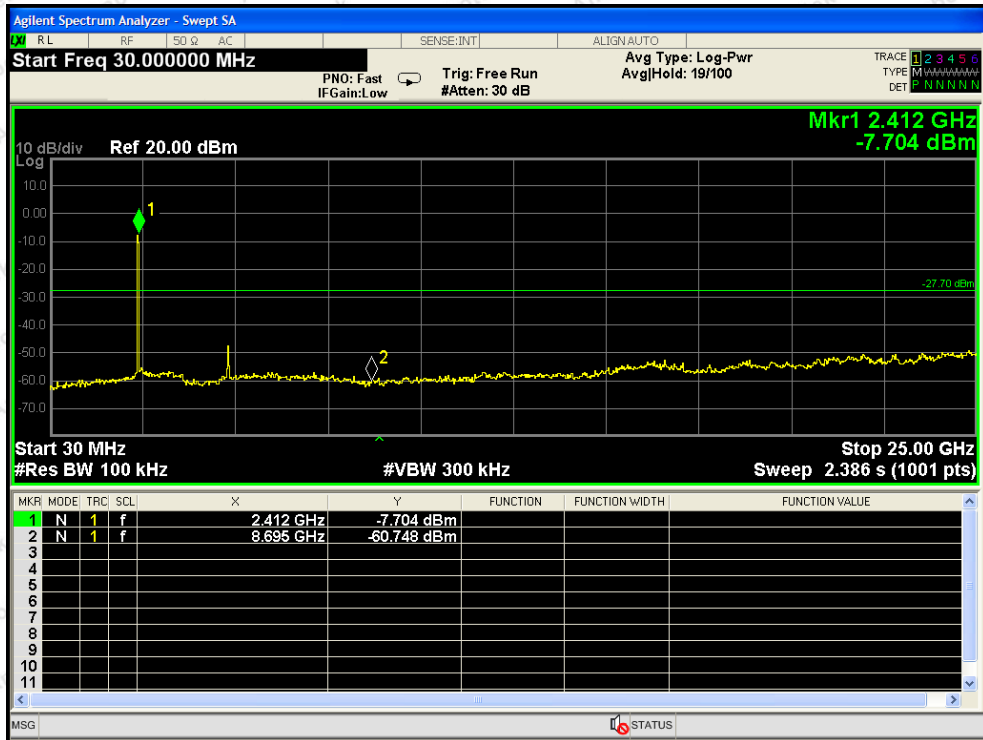

802.11n20 mode : Lowest

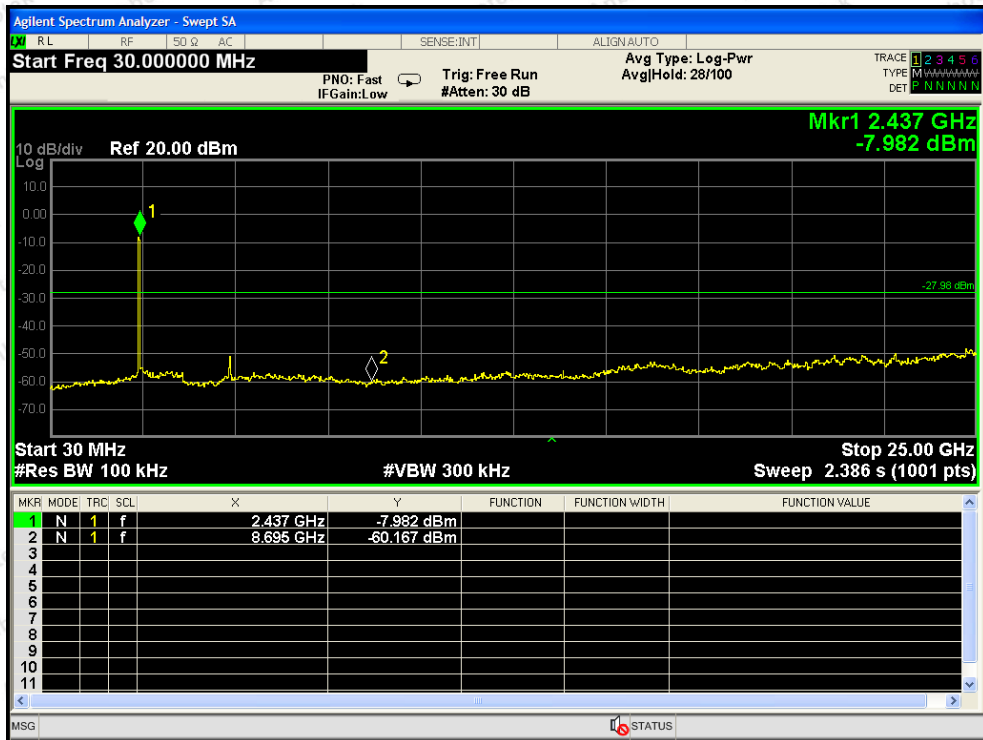

802.11n20 mode : Middle

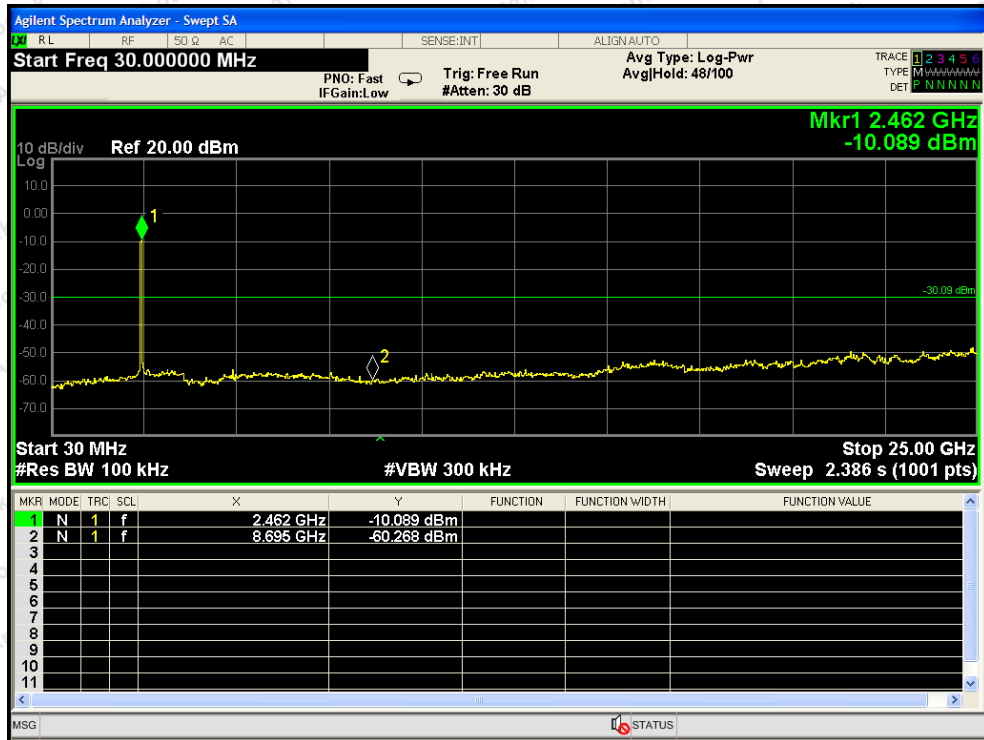

802.11n20 mode : Highest

## 9. Antenna Requirement

### 9.1. Test Standard and Requirement

Test Standard	FCC Part15 Section 15.203 /247(c)
Requirement	<p>1) 15.203 requirement: An intentional radiator shall be designed to ensure that no antenna other than that furnished by the responsible party shall be used with the device. The use of a permanently attached antenna or of an antenna that uses a unique coupling to the intentional radiator, the manufacturer may design the unit so that a broken antenna can be replaced by the user, but the use of a standard antenna jack or electrical connector is prohibited.</p> <p>2) 15.247(c) (1)(i) requirement: Systems operating in the 2400-2483.5 MHz band that is used exclusively for fixed. Point-to-point operations may employ transmitting antennas with directional gain greater than 6dBi provided the maximum conducted output power of the intentional radiator is reduced by 1 dB for every 3 dB that the directional gain of the antenna exceeds 6 dBi.</p>

### 9.2. Antenna Connected Construction

The an antenna that uses a unique coupling to the intentional radiator, the manufacturer may design the unit so that a broken antenna can be replaced by the user, but the use of a standard antenna jack or electrical connector is prohibited., and the best case gain of the antenna is 3.86 dBi. It complies with the standard requirement.



## APPENDIX I -- TEST SETUP PHOTOGRAPH

Photo of Power Line Conducted Emission Test



Photo of Radiation Emission Test

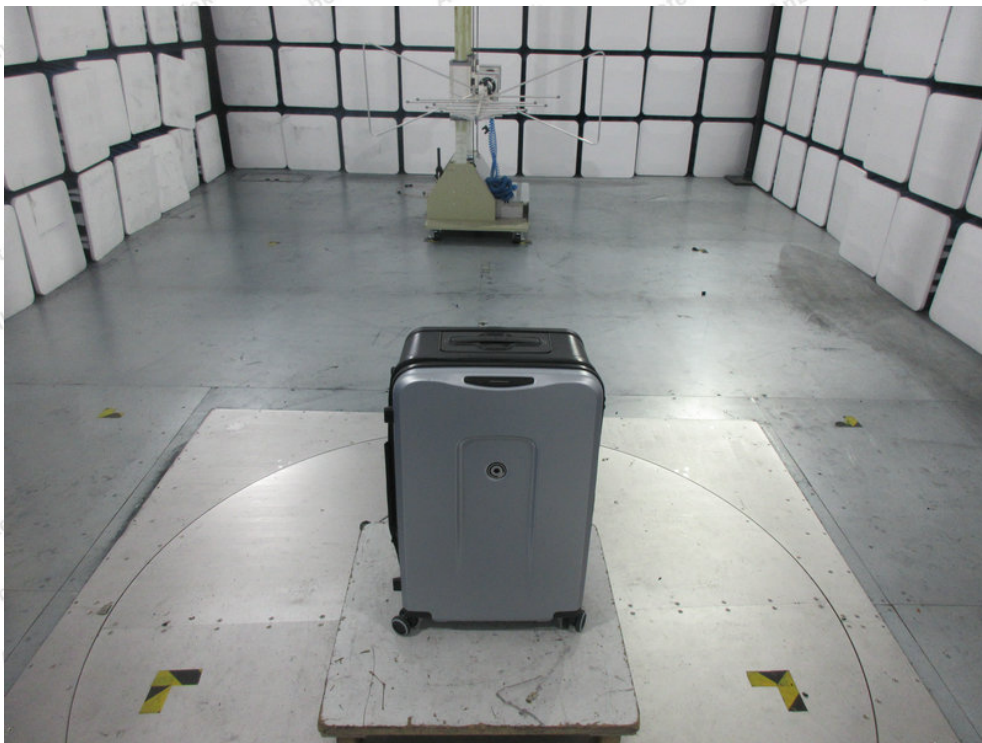

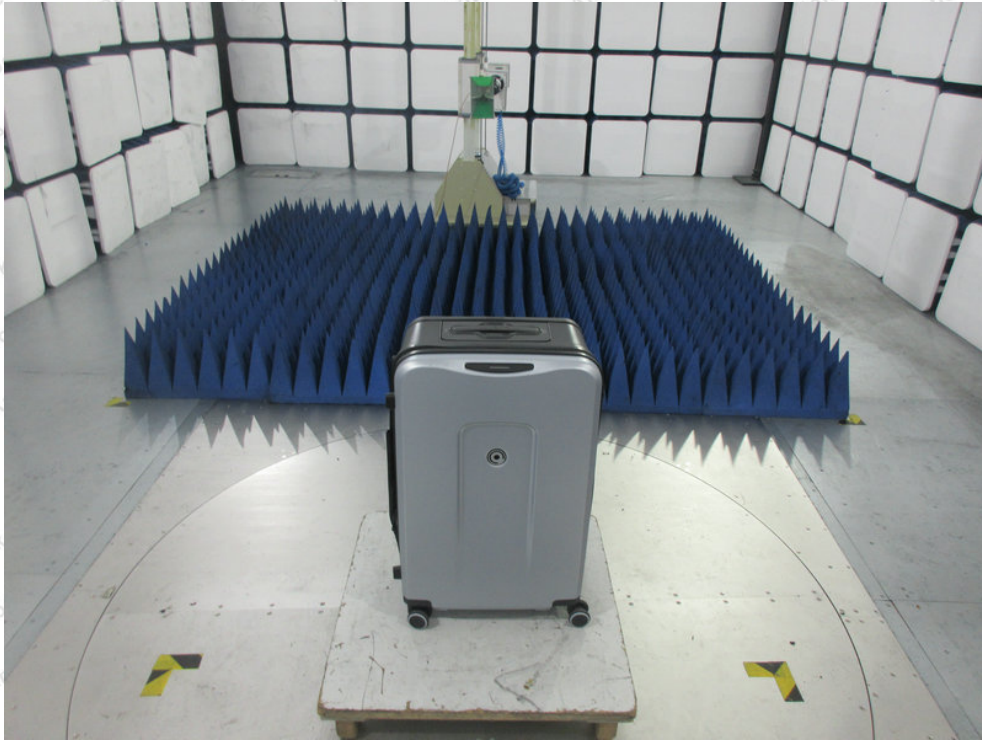

## APPENDIX II -- PHOTOGRAPH

Reference to the test report SZAWW190215004-01

----- End of Report -----

**Shenzhen Anbotek Compliance Laboratory Limited**

**Code:AB-RF-05-a**

Address: 1/F, Building D, Sogood Science and Technology Park, Sanwei Community,  
Hangcheng Street, Bao'an District, Shenzhen, Guangdong, China.  
Tel:(86)755-26066440 Fax:(86)755-26014772 Email:service@anbotek.com



Hotline  
400-003-0500  
www.anbotek.com