



# TEST REPORT

Report No. .... : **CHTEW19080146** Report verification : 

Project No. .... : **SHT1907048510EW**

FCC ID..... : **2ASNSRT27V**

Applicant's name ..... : **Shenzhen Retevis Technology Co., Ltd.**

Address..... : Room 700, 7/F, 13-C, Zhonghaixin Science&Technology Park, No.12 Ganli 6th Road, Jihua Street, Longgang District, Shenzhen, China

Manufacturer..... : Shenzhen Retevis Technology Co., Ltd.

Address..... : Room 700, 7/F, 13-C, Zhonghaixin Science&Technology Park, No.12 Ganli 6th Road, Jihua Street, Longgang District, Shenzhen, China

Test item description ..... : **Two Way Radio**

Trade Mark ..... : RETEVIS

Model/Type reference..... : RT27V

Listed Model(s) ..... : -

Standard ..... : **FCC Part 95J**

Date of receipt of test sample..... : Aug.13, 2019

Date of testing..... : Aug.13, 2019-Aug.23, 2019

Date of issue..... : Aug.26, 2019

Result..... : **PASS**

Compiled by  
( position+printed name+signature)..: File administrators Echo Wei 

Supervised by  
( position+printed name+signature)..: Project Engineer Edward Pan 

Approved by  
( position+printed name+signature)..: RF Manager Hans Hu 

Testing Laboratory Name ..... : **Shenzhen Huatongwei International Inspection Co., Ltd.**

Address..... : 1/F, Bldg 3, Hongfa Hi-tech Industrial Park, Genyu Road, Tianliao, Gongming, Shenzhen, China

**Shenzhen Huatongwei International Inspection Co., Ltd. All rights reserved.**

This publication may be reproduced in whole or in part for non-commercial purposes as long as the Shenzhen Huatongwei International Inspection Co., Ltd. is acknowledged as copyright owner and source of the material. Shenzhen Huatongwei International Inspection Co., Ltd. takes no responsibility for and will not assume liability for damages resulting from the reader's interpretation of the reproduced material due to its placement and context.

*The test report merely corresponds to the test sample.*

## Contents

<b>1.</b>	<b><u>TEST STANDARDS AND REPORT VERSION</u></b>	<b>3</b>
1.1.	Test Standards	3
1.2.	Report version information	3
<b>2.</b>	<b><u>TEST DESCRIPTION</u></b>	<b>4</b>
<b>3.</b>	<b><u>SUMMARY</u></b>	<b>5</b>
3.1.	Client Information	5
3.2.	Product Description	5
3.3.	Test frequency list	6
3.4.	EUT operation mode	6
3.5.	EUT configuration	6
<b>4.</b>	<b><u>TEST ENVIRONMENT</u></b>	<b>7</b>
4.1.	Address of the test laboratory	7
4.2.	Test Facility	7
4.3.	Environmental conditions	8
4.4.	Statement of the measurement uncertainty	8
4.5.	Equipments Used during the Test	9
<b>5.</b>	<b><u>TEST CONDITIONS AND RESULTS</u></b>	<b>10</b>
5.1.	Maximum Transmitter Power	10
5.2.	Occupied Bandwidth	11
5.3.	Emission Mask	12
5.4.	Audio Low Pass Filter Response	14
5.5.	Frequency stability VS Temperature	15
5.6.	Frequency stability VS Voltage	16
5.7.	Spurious Emission on Antenna Port	17
5.8.	Transmitter Radiated Spurious Emission	18
5.9.	AC Power Line Conducted Emission	23
5.10	Radiated Emission	26
<b>6.</b>	<b><u>TEST SETUP PHOTOS OF THE EUT</u></b>	<b>29</b>
<b>7.</b>	<b><u>EXTERNAL AND INTERNAL PHOTOS OF THE EUT</u></b>	<b>31</b>
<b>8.</b>	<b><u>APPENDIX REPORT</u></b>	<b>37</b>

## 1. TEST STANDARDS AND REPORT VERSION

### 1.1. Test Standards

The tests were performed according to following standards:

[FCC Rules Part 2](#): Frequency allocations and radio treaty matters; General rules and regulations

[FCC Rules Part 95J](#): Multi-Use Radio Service

[ANSI/TIA-603-E\(2016\)](#): Land Mobile FM or PM Communications Equipment and Performance Standards

[ANSI C63.4-2014](#): American National Standard for Methods of Measurement of Radio-Noise Emissions from Low-Voltage Electrical and Electronic Equipment in the Range of 9 kHz to 40 GHz

### 1.2. Report version information

Revision No.	Date of issue	Description
N/A	2019-08-26	Original

## 2. Test Description

Test Item	Section in CFR 47	Result	Test Engineer
Maximum Transmitter Power	FCC Part 95.2767, FCC Part 2.1046	Pass	Bruse.Li
Occupied Bandwidth	FCC Part 95.2773, FCC Part 2.1049	Pass	Bruse.Li
Emission Mask	FCC Part 95.2779, Part 2.1049	Pass	Bruse.Li
Audio Low Pass Filter Response	FCC Part 95.2775, Part 2.1047(a)	Pass	Bruse.Li
Frequency Stability V.S. Temperature	FCC Part 95.2765, Part 2.1055	Pass	Bruse.Li
Frequency Stability V.S. Voltage	FCC Part 95.2765, Part 2.1055	Pass	Bruse.Li
Transmit Radiated Spurious Emission	FCC Part 95.2779, Part 2.1053	Pass	Pan Xie
Spurious Emission On Antenna Port	FCC Part 95.2779, Part 2.1053	Pass	Bruse.Li

### 3. SUMMARY

#### 3.1. Client Information

Applicant:	Shenzhen Retevis Technology Co., Ltd.
Address:	Room 700, 7/F, 13-C, Zhonghaixin Science&Technology Park, No.12 Ganli 6th Road, Jihua Street, Longgang District, Shenzhen, China
Manufacturer:	Shenzhen Retevis Technology Co., Ltd.
Address:	Room 700, 7/F, 13-C, Zhonghaixin Science&Technology Park, No.12 Ganli 6th Road, Jihua Street, Longgang District, Shenzhen, China

#### 3.2. Product Description

Name of EUT:	Two Way Radio
Trade mark:	RETEVIS
Model/Type reference:	RT27V
Listed model(s):	-
Power supply:	DC 3.7V
Battery information:	Model: RT27 3.7V DC 1100mAh(4.07Wh)
Charger information:	Model:RT27 Input: DC 5V Output: DC 4.2Vd.c.,500mA
Adapter information:	Model: DSA-5PF07-05 FUS 050100 Input:100-240Va.c.,50/60Hz 0.2A Output:5Vd.c.,1A
<b>RF Specification</b>	
Operation Frequency Range:	151.820MHz, 151.880MHz, 151.940MHz, 154.570MHz, 154.600MHz
Rated Output Power:	0.5W
Modulation Type:	FM(Analog)
Authorized Bandwidth:	<input checked="" type="checkbox"/> 11.25kHz <input checked="" type="checkbox"/> 20kHz
Emission Designator*:	<input checked="" type="checkbox"/> 11.25kHz Authorized Bandwidth: 11K0F3E <input checked="" type="checkbox"/> 20kHz Authorized Bandwidth: 16K0F3E
Antenna Type:	Intergral
Antenna Gain:	1.5dBi

Note:

(1) \*1 According to FCC Part 2.202 requirements, the Necessary Bandwidth is calculated as follows:

- For FM Voice Modulation

Authorized Bandwidth = 11.25 KHz, D = 2.5 KHz max, K = 1, M = 3 KHz

$B_n = 2M + 2DK = 2*3 + 2*2.5*1 = 11 \text{ KHz}$

Emission designation: 11K0F3E

Authorized Bandwidth = 25 KHz, D = 5 KHz max, K = 1, M = 3 KHz

$B_n = 2M + 2DK = 2*3 + 2*5*1 = 16 \text{ KHz}$

Emission designation: 16K0F3E

(2) The device only supports voice communication.

### 3.3. Test frequency list

Mode	Modulation	Authorized Bandwidth (kHz)	Test Frequency (MHz)
Analog	FM	11.25	CH <sub>L</sub> 151.82
			CH <sub>M1</sub> 151.88
			CH <sub>M2</sub> 151.94
		20	CH <sub>M3</sub> 154.57
			CH <sub>H</sub> 154.60

### 3.4. EUT operation mode

Test mode	Transmitting	Receiving	Analog Voice/FM
			MURS
TX	√		√
RX		√	√

Note: √ is operation mode.

Modulation Type	Description
UM	Un-modulation
AM2	Apply a 1000 Hz tone and adjust the audio frequency generator to produce 20% of the rated system deviation.
AM6	Apply a 1000 Hz modulating signal to the transmitter from the audio frequency generator, and adjust the level to obtain 60% of full rated system deviation, then increase the level from the audio generator by 20 dB
AM5	Modulate the transmitter with a 2500 Hz sine wave at an input level 16 dB greater than that necessary to produce 50% of rated system deviation.

Test item	Modulation Type	Test mode
Maximum Transmitter Power	UM	TX
Occupied Bandwidth	AM6	TX
Emission Mask	AM5	TX
Audio Low Pass Filter Response	AM2	TX
Frequency Stability V.S. Temperature	UM	TX
Frequency Stability V.S. Voltage	UM	TX
Transmit Radiated Spurious Emission	AM5	TX
Spurious Emission On Antenna Port	AM5	TX
Conducted emission (AC port)		RX
Radiated emission		RX

### 3.5. EUT configuration

The following peripheral devices and interface cables were connected during the measurement:

- - supplied by the manufacturer
- - supplied by the lab

○ Power Cable	Length (m) :	/
	Shield :	/
	Detachable :	/
○ Multimeter	Manufacturer :	/
	Model No. :	/

## **4. TEST ENVIRONMENT**

### **4.1. Address of the test laboratory**

Laboratory: Shenzhen Huatongwei International Inspection Co., Ltd.

Address: 1/F, Bldg 3, Hongfa Hi-tech Industrial Park, Genyu Road, Tianliao, Gongming, Shenzhen, China

Phone: 86-755-26748019 Fax: 86-755-26748089

### **4.2. Test Facility**

The test facility is recognized, certified, or accredited by the following organizations:

#### **CNAS-Lab Code: L1225**

Shenzhen Huatongwei International Inspection Co., Ltd. has been assessed and proved to be in compliance with CNAS-CL01 Accreditation Criteria for Testing and Calibration Laboratories (identical to ISO/IEC17025: 2005 General Requirements) for the Competence of Testing and Calibration Laboratories.

#### **A2LA-Lab Cert. No.: 3902.01**

Shenzhen Huatongwei International Inspection Co., Ltd. EMC Laboratory has been accredited by A2LA for technical competence in the field of electrical testing, and proved to be in compliance with ISO/IEC 17025: 2005 General Requirements for the Competence of Testing and Calibration Laboratories and any additional program requirements in the identified field of testing.

#### **FCC-Registration No.: 762235**

Shenzhen Huatongwei International Inspection Co., Ltd. EMC Laboratory has been registered and fully described in a report filed with the FCC (Federal Communications Commission). The acceptance letter from the FCC is maintained in our files. Registration 762235.

#### **IC-Registration No.: 5377A**

Two 3m Alternate Test Site of Shenzhen Huatongwei International Inspection Co., Ltd. has been registered by Certification and Engineering Bureau of Industry Canada for the performance of radiated measurements with Registration No. 5377A.

#### **ACA**

Shenzhen Huatongwei International Inspection Co., Ltd. EMC Laboratory can also perform testing for the Australian C-Tick mark as a result of our A2LA accreditation.

### 4.3. Environmental conditions

Atmospheric Contions	
Temperature:	21°C to 25°C
Relative Humidity:	20 % to 75 %.
Atmospheric Pressure:	860 mbar to 1060 mbar
Norminal Test Voltage:	$V_N = DC 3.7V$
Extrem Test Voltage @115% $V_N$ :	$V_H = DC 4.26V$
Extrem Test Voltage @85% $V_N$ :	$V_L = DC 3.15V$

### 4.4. Statement of the measurement uncertainty

The data and results referenced in this document are true and accurate. The reader is cautioned that there may be errors within the calibration limits of the equipment and facilities. The measurement uncertainty was calculated for all measurements listed in this test report acc. to CISPR 16 - 4 „Specification for radio disturbance and immunity measuring apparatus and methods – Part 4: Uncertainty in EMC Measurements“ and is documented in the Shenzhen Huatongwei International Inspection Co., Ltd quality system acc. to DIN EN ISO/IEC 17025. Furthermore, component and process variability of devices similar to that tested may result in additional deviation. The manufacturer has the sole responsibility of continued compliance of the device.

Hereafter the best measurement capability for Shenzhen Huatongwei laboratory is reported:

Test Items	Measurement Uncertainty	Notes
Frequency stability & Occupied Bandwidth	15Hz for <1GHz 70Hz for >1GHz	(1)
Conducted Output Power	0.51dB	(1)
ERP / EIRP / RSE	2.66dB for <1GHz 3.44dB for >1GHz	(1)
Conducted Emission 9KHz-30MHz	3.02dB	(1)
Radiated Emission 30~1000MHz	4.90dB	(1)
Radiated Emission 1~18GHz	4.96dB	(1)
FM deviation	25 Hz	(1)
Audio level	0.62 dB	(1)
Low Pass Filter Response	0.76 dB	(1)
Modulation Limiting	0.42 %	(1)

(1) This uncertainty represents an expanded uncertainty expressed at approximately the 95% confidence level using a coverage factor of  $k=1.96$ .



#### 4.5. Equipments Used during the Test

● TS8613 Test system						
Used	Test Equipment	Manufacturer	Model No.	Serial No.	Last Cal. Date (YY-MM-DD)	Next Cal. Date (YY-MM-DD)
●	Spectrum Analyzer	Agilent	N9020A	MY50510187	2018/09/29	2019/09/28
●	Signal & Spectrum Analyzer	R&S	FSW26	103440	2018/10/28	2019/10/27
●	RF Communication Test Set	HP	8920A	3813A10206	2018/10/28	2019/10/27
●	Digital intercom communication tester	Aeroflex	3920B	1001682041	2018/10/28	2019/10/27
●	Signal Generator	R&S	SML02	100507	2018/10/27	2019/10/26
●	Signal Generator	IFR	2032	203002\100	2018/11/11	2019/11/10
●	RF Control Unit	Tonscend	JS0806-2	N/A	N/A	N/A
●	Fliter-VHF	Microwave	N26460M1	498702	2019/03/19	2020/03/18
○	Fliter-UHF	Microwave	N25155M2	498704	2019/03/19	2020/03/18
○	Power Divider	Microwave	OPD1040-N-4	N/A	2018/11/15	2019/11/14
○	Attenuator	JFW	50FH-030-100	N/A	2018/11/15	2019/11/14
○	Attenuator	JFW	50-A-MFN-20	0322	2018/11/15	2019/11/14
●	Test software	HTW	Radio ATE	N/A	N/A	N/A

● Auxiliary Equipment						
Used	Test Equipment	Manufacturer	Model No.	Serial No.	Last Cal. Date (YY-MM-DD)	Next Cal. Date (YY-MM-DD)
●	Climate chamber	ESPEC	GPL-2	N/A	2018/11/08	2019/11/07
●	DC Power Supply	Gwinstek	SPS-2415	GER835793	2018/10/28	2019/10/27

● Radiated Spurious Emission						
Used	Test Equipment	Manufacturer	Model No.	Serial No.	Last Cal. Date (YY-MM-DD)	Next Cal. Date (YY-MM-DD)
●	Semi-Anechoic Chamber	Albatross projects	SAC-3m-01	N/A	2018/09/30	2021/09/29
●	Spectrum Analyzer	R&S	FSP40	100597	2018/10/27	2019/10/26
●	Loop Antenna	R&S	HFH2-Z2	100020	2017/11/20	2020/11/19
●	Ultra-Broadband Antenna	SCHWARZBECK	VULB9163	538	2017/04/05	2020/04/04
●	Horn Antenna	SCHWARZBECK	9120D	1011	2017/04/01	2020/03/31
○	Horn Antenna	SCHWARZBECK	BBHA9170	25841	2017/03/27	2020/03/26
○	Pre-amplifier	BONN	BLWA0160-2M	1811887	2018/11/14	2019/11/13
●	Pre-amplifier	CD	PAP-0102	12004	2018/11/14	2019/11/13
●	Broadband Preamplifier	SCHWARZBECK	BBV 9718	9718-248	2019/05/23	2020/05/22
●	RF Connection Cable	HUBER+SUHNER	RE-7-FH	N/A	2018/11/15	2019/11/14
●	RF Connection Cable	HUBER+SUHNER	RE-7-FL	N/A	2018/11/15	2019/11/14
●	EMI Test Software	Audix	E3	N/A	N/A	N/A
●	Turntable	MATURO	TT2.0	N/A	N/A	N/A
●	Antenna Mast	MATURO	TAM-4.0-P	N/A	N/A	N/A

## 5. TEST CONDITIONS AND RESULTS

### 5.1. Maximum Transmitter Power

Applicants for licenses must request and use no more power than the actual power necessary for satisfactory operation.

#### LIMIT

##### **FCC Part 95.2741, FCC Part 2.1046**

The highest point of any MURS station antenna must not be more than 18.3 meters (60 feet) above the ground or 6.10 meters (20 feet) above the highest point of the structure on which it is mounted. MURS station antennas must also meet the requirements in §95.317 regarding menaces to air navigation. See 47 CFR 95.317 and consult part 17 of the FCC's Rules for more information (47 CFR part 17).

#### TEST CONFIGURATION

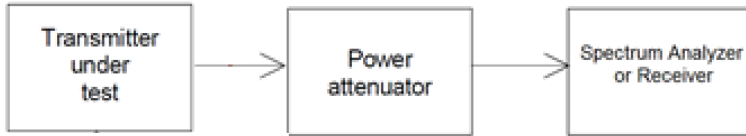

#### TEST PROCEDURE

Measurements shall be made to establish the radio frequency power delivered by the transmitter the standard output termination. The power output shall be monitored and recorded and no adjustment shall be made to the transmitter after the test has begun, except as noted bellow:

If the power output is adjustable, measurements shall be made for the highest and lowest power levels.

Connect the equipment as illustrated.

#### TEST MODE:

Please reference to the section 3.4

#### TEST RESULTS

**Passed**       **Not Applicable**

Please refer to appendix A on the section 8 appendix report

## 5.2. Occupied Bandwidth

The occupied bandwidth, that is the frequency bandwidth such that, below its lower and above its upper frequency limits.

### LIMIT

#### **FCC Part 95.2773, FCC Part 2.1049**

Each MURS transmitter type must be designed to meet the emission bandwidth limitations in this section.

- (a) The occupied bandwidth of emissions transmitted on the center frequencies 151.820 MHz, 151.880 MHz, and 151.940 MHz must not exceed 11.25 kHz.
- (b) The occupied bandwidth of emissions transmitted on the center frequencies 154.570 MHz and 154.600 MHz must not exceed 20.0 kHz.
- (c) The occupied bandwidth of type A3E emissions must not exceed 8.0 kHz.

### TEST CONFIGURATION

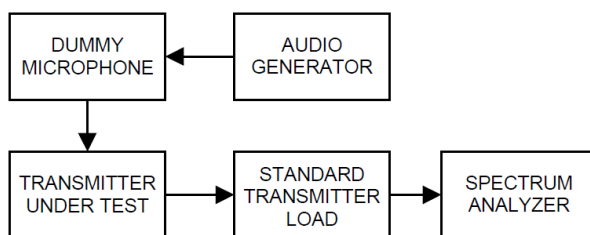

### TEST PROCEDURE

- 1 The EUT was modulated by 2.5kHz sine wave audio signal; the level of the audio signal employed is 16dB greater than that necessary to produce 50% of rated system deviation.
- 2 Spectrum set as follow:  
Centre frequency = fundamental frequency, span=50kHz for 12.5kHz channel spacing,  
RBW=100Hz, VBW=300Hz, Sweep = auto,  
Detector function = peak, Trace = max hold
- 3 Set 99% Occupied Bandwidth and 26dB Occupied Bandwidth
- 4 Measure and record the results in the test report.

### TEST MODE:

Please reference to the section 3.4

### TEST RESULTS

Passed       Not Applicable

Please refer to appendix B on the section 8 appendix report

### 5.3. Emission Mask

Transmitters used in the radio services governed by this part must comply with the emission masks outlined in this section.

#### LIMIT

FCC Part 95.2779, FCC Part 2.1049

(a) Emission masks. Emission masks applicable to transmitting equipment in the MURS are defined by the requirements in the following table. The numbers in the paragraphs column refer to attenuation requirement rule paragraph numbers under paragraph (b) of this section. The words “audio filter” refer to the audio filter described in §95.2775.

Channel center frequencies (MHz)	Paragraphs
151.820, 151.880 and 151.940	(1), (2).
154.570 & 154.600, with audio filter	(3), (4), (7).
154.570 & 154.600, without audio filter	(5), (6), (7).

- (1) Each MURS transmitter type that transmits F3E or G3E emissions on 154.570 MHz or 154.600 MHz and incorporates an audio filter satisfying the requirements of §95.2775 in its design may comply with the less stringent unwanted emissions attenuation requirements set forth in paragraphs (b)(3), (4), and (7) of this section.
- (2) Each MURS transmitter type that transmits on 154.570 MHz or 154.600 MHz, but does not incorporate an audio filter satisfying the requirements of §95.2775 in its design, must comply with the unwanted emissions attenuation requirements set forth in paragraphs (b)(5) through (7) of this section.
- (b) Attenuation requirements. The power of unwanted emissions must be attenuated below the transmitter output power in Watts (P) by at least:
  - (1)  $7.27(f_d - 2.88 \text{ kHz})$  dB on any frequency removed from the channel center frequency by a displacement frequency ( $f_d$  in kHz) that is more than 5.625 kHz, but not more than 12.5 kHz.
  - (2)  $50 + 10 \log(P)$  dB or 70 dB, whichever is the lesser attenuation, on any frequency removed from the channel center frequency by more than 12.5 kHz.
  - (3) 25 dB on any frequency removed from the channel center frequency by more than 10 kHz, but not more than 20 kHz.
  - (4) 35 dB on any frequency removed from the channel center frequency by more than 20 kHz, but not more than 50 kHz.
  - (5)  $83 \log(f_d \div 5)$  dB on any frequency removed from the center of the authorized bandwidth by a displacement frequency ( $f_d$  in kHz) that is more than 5 kHz, but not more than 10 kHz.
  - (6)  $29 \log(f_d^2 \div 11)$  dB or 50 dB, whichever is the lesser attenuation on any frequency removed from the channel center frequency by a displacement frequency ( $f_d$  in kHz) that is more than 10 kHz, but not more than 50 kHz.
  - (7)  $43 + 10 \log(P)$  dB on any frequency removed from the channel center frequency by more than 50 kHz.
- (c) Measurement bandwidths. The power of unwanted emissions in the frequency bands specified in paragraphs (b)(1) and (3) through (6) of this section is measured with a reference bandwidth of 300 Hz. The power of unwanted emissions in the frequency ranges specified in paragraphs (b)(2) and (7) of this section is measured with a reference bandwidth of at least 30 kHz.

#### TEST CONFIGURATION

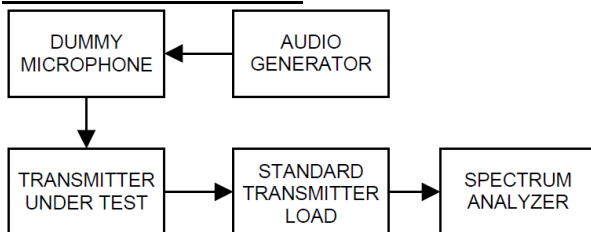

#### TEST PROCEDURE

- 1 Connect the equipment as illustrated.
- 2 Spectrum set as follow:  
Centre frequency = fundamental frequency, span=120kHz ,RBW=300Hz, VBW=1kHz,  
Sweep = auto, Detector function = peak, Trace = max hold
- 3 Key the transmitter, and set the level of the unmodulated carrier to a full scale reference line. This is the 0dB reference for the measurement.
- 4 Modulate the transmitter with a 2500 Hz sine wave at an input level 16 dB greater than that necessary to

produce 50% of rated system deviation. The input level shall be established at the frequency of maximum response of the audio modulating circuit. Transmitters employing digital modulation techniques that bypass the limiter and the audio low-pass filter shall be modulated as specified by the manufacturer

5 Measure and record the results in the test report.

**TEST MODE:**

Please reference to the section 3.4

**TEST RESULTS**

**Passed**       **Not Applicable**

Please refer to appendix C on the section 8 appendix report

### 5.4. Audio Low Pass Filter Response

The audio low pass filter response is the frequency response of the post limiter low pass filter circuit above 3000 Hz.

**LIMIT**

FCC Part 95.2775:

- (a) The audio filter must be between the modulation limiter and the modulated stage of the transmitter.
- (b) At any frequency (f in kHz) between 3 and 15 kHz, the filter must have an attenuation of at least  $40 \log(f/3)$  dB more than the attenuation at 1 kHz. Above 15 kHz, it must have an attenuation of at least 28 dB more than the attenuation at 1 kHz.

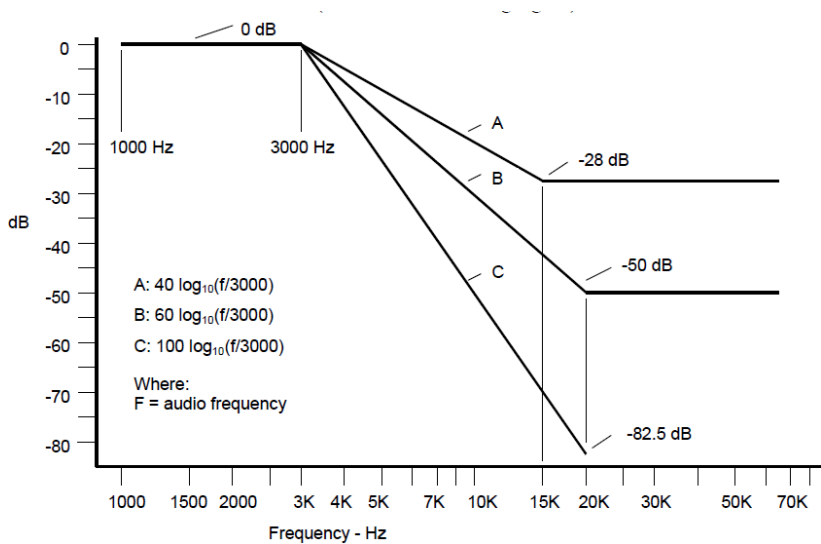

**TEST CONFIGURATION**

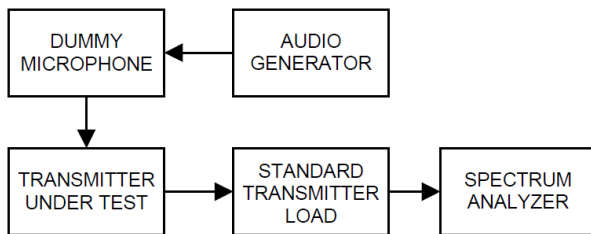

**TEST PROCEDURE**

- 1) Configure the EUT as shown in figure .
- 2) Apply a 1000Hz tone from the audio signal generator and adjust the level per manufacturer's specifications. Record the dB level of the 1000 Hz tone as  $LEV_{REF}$ .
- 3) Set the audio signal generator to the desired test frequency between 3000 Hz and the upper low pass filter limit. Record the dB level at the test frequency as  $LEV_{FREQ}$ .
- 4) Calculate the audio frequency response at the test frequency as:  
 low pass filter response =  $LEV_{FREQ} - LEV_{REF}$

**TEST MODE:**

Please reference to the section 3.4

**TEST RESULTS**

Passed       Not Applicable

Please refer to appendix D on the section 8 appendix report

## 5.5. Frequency stability VS Temperature

The carrier frequency stability is the ability of the transmitter to maintain an assigned carrier frequency.

### LIMIT

#### **FCC Part 95.2765, FCC Part 2.1055**

Each MURS transmitter type must be designed to meet the applicable frequency tolerance and stability requirements of this section.

- (a) MURS transmitters that operate with an emission bandwidth of 6.25 kHz or less must be designed such that the carrier frequencies remain within  $\pm 2.0$  parts-per-million (ppm) of the channel center frequencies specified in §95.2763 during normal operating conditions.
- (b) MURS transmitters that operate with an emission bandwidth greater than 6.25 kHz must be designed such that the carrier frequencies remain within  $\pm 5.0$  ppm of the channel center frequencies specified in §95.2763 during normal operating conditions.

### TEST CONFIGURATION

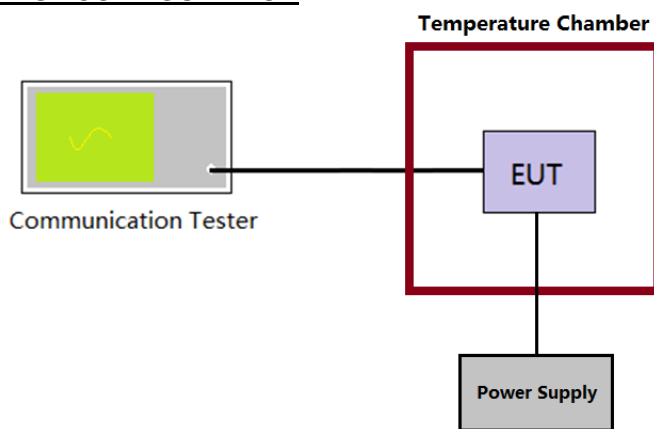

### TEST PROCEDURE

1. The EUT output port was connected to communication tester.
2. The EUT was placed inside the temperature chamber.
3. Turn EUT off and set the chamber temperature to  $-30^{\circ}\text{C}$ . After the temperature stabilized for approximately 30 minutes recorded the frequency as  $MCF_{\text{MHz}}$ .
4. Calculate the ppm frequency error by the following:  

$$\text{ppm error} = (MCF_{\text{MHz}} / ACF_{\text{MHz}} - 1) * 10^6$$
 where  
 $MCF_{\text{MHz}}$  is the Measured Carrier Frequency in MHz  
 $ACF_{\text{MHz}}$  is the Assigned Carrier Frequency in MHz
5. Repeat step 3 measure with  $10^{\circ}\text{C}$  increased per stage until the highest temperature of  $+50^{\circ}\text{C}$  reached.

### TEST MODE

Please reference to the section 3.4

### TEST RESULTS

Passed       Not Applicable

Please refer to appendix E on the section 8 appendix report

## 5.6. Frequency stability VS Voltage

The carrier frequency stability is the ability of the transmitter to maintain an assigned carrier frequency.

### LIMIT

#### **FCC Part 95.2765, FCC Part 2.1055**

Each MURS transmitter type must be designed to meet the applicable frequency tolerance and stability requirements of this section.

- (a) MURS transmitters that operate with an emission bandwidth of 6.25 kHz or less must be designed such that the carrier frequencies remain within  $\pm 2.0$  parts-per-million (ppm) of the channel center frequencies specified in §95.2763 during normal operating conditions.
- (b) MURS transmitters that operate with an emission bandwidth greater than 6.25 kHz must be designed such that the carrier frequencies remain within  $\pm 5.0$  ppm of the channel center frequencies specified in §95.2763 during normal operating conditions.

### TEST CONFIGURATION

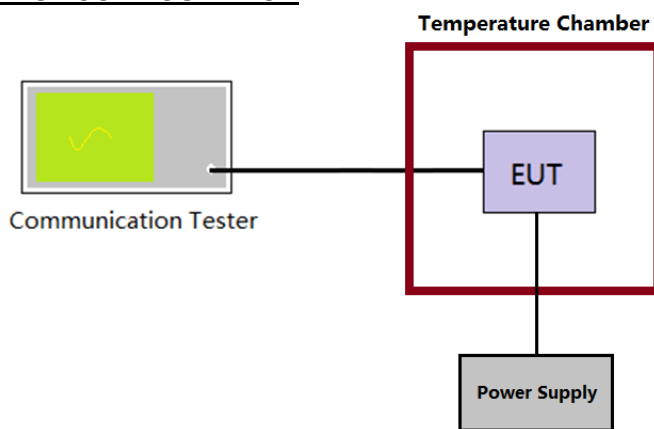

### TEST PROCEDURE

- 1) The EUT output port was connected to communication tester.
- 2) The EUT was placed inside the temperature chamber at 25°C
- 3) Record the carrier frequency of the transmitter as  $MCF_{MHz}$
- 4) Calculate the ppm frequency error by the following:  

$$ppm\ error = (MCF_{MHz} / ACF_{MHz} - 1) * 10^6$$
 where  
 $MCF_{MHz}$  is the Measured Carrier Frequency in MHz  
 $ACF_{MHz}$  is the Assigned Carrier Frequency in MHz
- 5) Repeat step 3 measure with varied  $\pm 15\%$  of the nominal value measured at the input to the EUT

### TEST MODE

Please reference to the section 3.4

### TEST RESULTS

Passed       Not Applicable

Please refer to appendix F on the section 8 appendix report



## 5.7. Spurious Emission on Antenna Port

Conducted spurious emissions are emissions at the antenna terminals on a frequency or frequencies that are outside a band sufficient to ensure transmission of information of required quality for the class of communication desired

### LIMIT

FCC Part 95.2779 (b)(2):

$50 + 10 \log(P)$  dB or 70 dB, whichever is the lesser attenuation, on any frequency removed from the channel center frequency by more than 12.5 kHz.

Limit (dBm) = P( dBm)-50-10 log (Pwatts) = -20dBm

FCC Part 95.2779 (b)(7)

$43 + 10 \log(P)$  dB on any frequency removed from the channel center frequency by more than 50 kHz

Limit (dBm) = P( dBm)-43-10 log (Pwatts) = -13dBm

### TEST CONFIGURATION

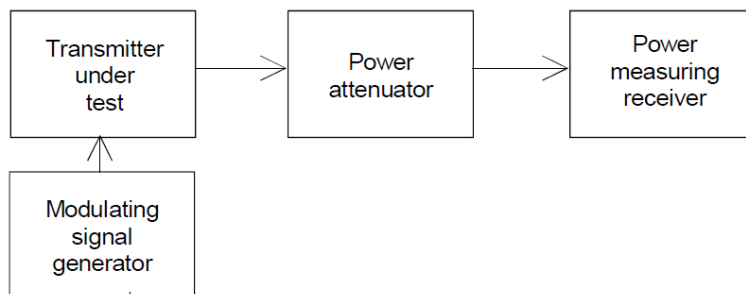

### TEST PROCEDURE

1. The RF output of the EUT was connected to a spectrum analyzer through appropriate attenuation.
2. The resolution bandwidth of the spectrum analyzer was set to 100 kHz. Sufficient scans were taken to show any out of band emission up to 10<sup>th</sup>. Harmonic for the lower and the highest frequency range.
3. Set RBW 100 kHz, VBW 300 kHz in the frequency band 30MHz to 1GHz, while set RBW=1MHz. VBW=3MHz from the 1GHz to 10<sup>th</sup> Harmonic.
4. The audio input was set the unmodulated carrier, the resulting picture is print out for each channel separation.

### TEST MODE:

Please reference to the section 3.4

### TEST RESULTS

Passed       Not Applicable

Please refer to appendix G on the section 8 appendix report

### 5.8. Transmitter Radiated Spurious Emission

Radiated spurious emissions are emissions from the equipment when transmitting into a nonradiating load on a frequency or frequencies that are outside an occupied band sufficient to ensure transmission of information of required quality for the class of communications desired.

#### LIMIT

FCC Part 95.2779 (b)(2):

50 + 10 log (P) dB or 70 dB, whichever is the lesser attenuation, on any frequency removed from the channel center frequency by more than 12.5 kHz.

$$\text{Limit (dBm)} = P(\text{ dBm}) - 50 - 10 \log (P_{\text{watts}}) = -20\text{dBm}$$

FCC Part 95.2779 (b)(7)

43 + 10 log(P) dB on any frequency removed from the channel center frequency by more than 50 kHz

$$\text{Limit (dBm)} = P(\text{ dBm}) - 43 - 10 \log (P_{\text{watts}}) = -13\text{dBm}$$

#### TEST CONFIGURATION

Below 1GHz:

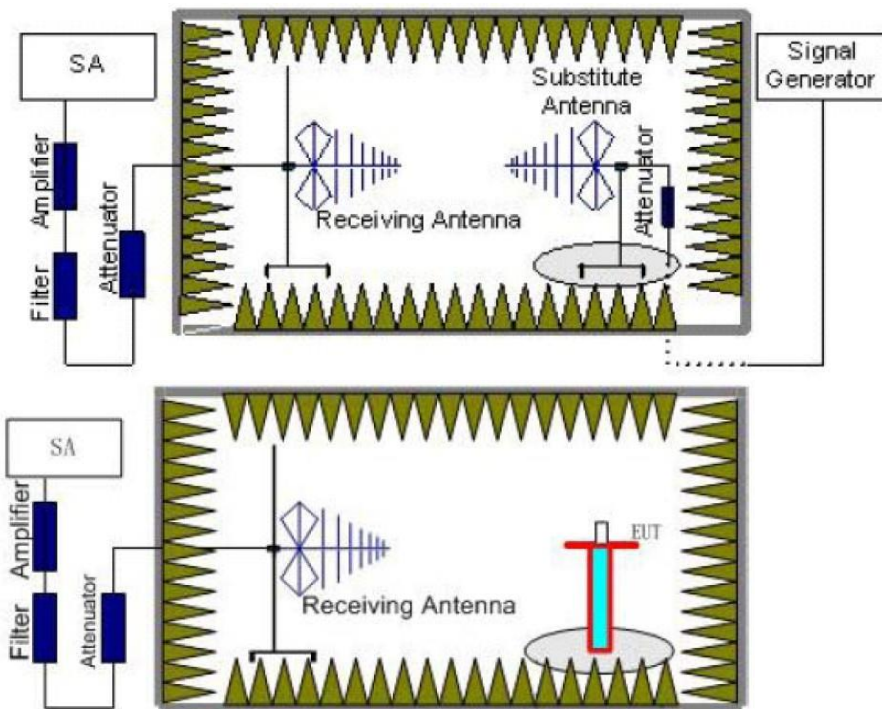

Above 1GHz:

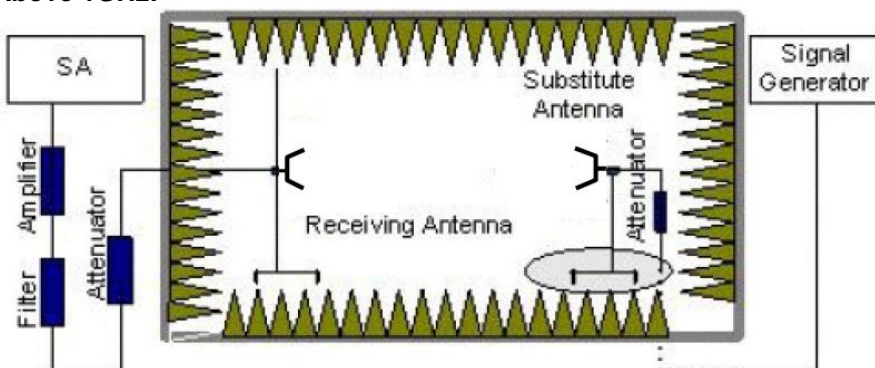

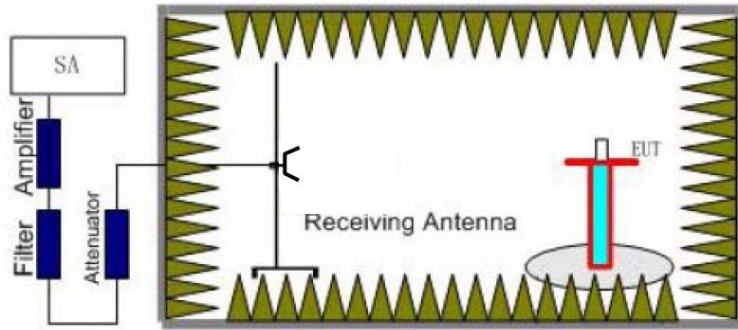

## TEST PROCEDURE

1. Place the EUT in the center of the turntable.
  - a) For radiated emissions measurements performed at frequencies less than or equal to 1 GHz, the EUT shall be placed on a RF-transparent table at a nominal height of 80 cm above the reference ground plane
  - b) For radiated measurements performed at frequencies above 1 GHz, the EUT shall be placed on an RF transparent table at a nominal height of 1.5 m above the ground plane.
2. Unless the EUT uses an integral antenna, the EUT shall be terminated with a non-radiating transmitter load. In cases where the EUT uses an adjustable antenna, the antenna shall be adjusted through typical positions and lengths to maximize emissions levels.
3. The EUT shall be tested while operating on the frequency per manufacturer specification. Set the transmitter to operate in continuous transmit mode.
4. Receiver or Spectrum set as follow:
  - Below 1GHz, RBW=100kHz, VBW=300kHz, Detector=Peak, Sweep time=Auto
  - Above 1GHz, RBW=1MHz, VBW=3MHz, Detector=Peck, Sweep time=Auto
5. Each emission under consideration shall be evaluated:
  - a) Raise and lower the measurement antenna from 1 m to 4 m, as necessary to enable detection of the maximum emission amplitude relative to measurement antenna height.
  - b) Rotate the EUT through 360° to determine the maximum emission level relative to the axial position.
  - c) Return the turntable to the azimuth where the highest emission amplitude level was observed.
  - d) Vary the measurement antenna height again through 1 m to 4 m again to find the height associated with the maximum emission amplitude.
  - e) Record the measured emission amplitude level and frequency
6. Repeat step 5 for each emission frequency with the measurement antenna oriented in both the horizontal and vertical polarizations to determine the orientation that gives the maximum emissions amplitude.
7. Set-up the substitution measurement with the reference point of the substitution antenna located as near as possible to where the center of the EUT radiating element was located during the initial EUT measurement.
8. Maintain the previous measurement instrument settings and test set-up, with the exception that the EUT is removed and replaced by the substitution antenna.
9. Connect a signal generator to the substitution antenna; locate the signal generator so as to minimize any potential influences on the measurement results. Set the signal generator to the frequency where emissions are detected, and set an output power level such that the radiated signal can be detected by the measurement instrument, with sufficient dynamic range relative to the noise floor.
10. For each emission that was detected and measured in the initial test
  - a) Vary the measurement antenna height between 1 m to 4 m to maximize the received (measured) signal amplitude.
  - b) Adjust the signal generator output power level until the amplitude detected by the measurement instrument equals the amplitude level of the emission previously measured directly in step 5 and step 6.
  - c) Record the output power level of the signal generator when equivalence is achieved in step b).
11. Repeat step 8 through step 10 with the measurement antenna oriented in the opposite polarization.
12. Calculate the emission power in dBm referenced to a half-wave dipole using the following equation:
 
$$P_e = P_s(\text{dBm}) - \text{cable loss (dB)} + \text{antenna gain (dBd)}$$
 where
  - $P_e$  = equivalent emission power in dBm
  - $P_s$  = source (signal generator) power in dBm
 NOTE—dBd refers to the measured antenna gain in decibels relative to a half-wave dipole.
13. Correct the antenna gain of the substitution antenna if necessary to reference the emission power to a half-wave dipole. When using measurement antennas with the gain specified in dBi, the equivalent dipole-referenced gain can be determined from:
 
$$\text{gain (dBd)} = \text{gain (dBi)} - 2.15 \text{ dB.}$$
 If necessary, the antenna gain can be calculated from calibrated antenna factor information

14. Provide the complete measurement results as a part of the test report.

**TEST MODE:**

Please reference to the section 3.4

**TEST RESULTS**

**Passed**       **Not Applicable**

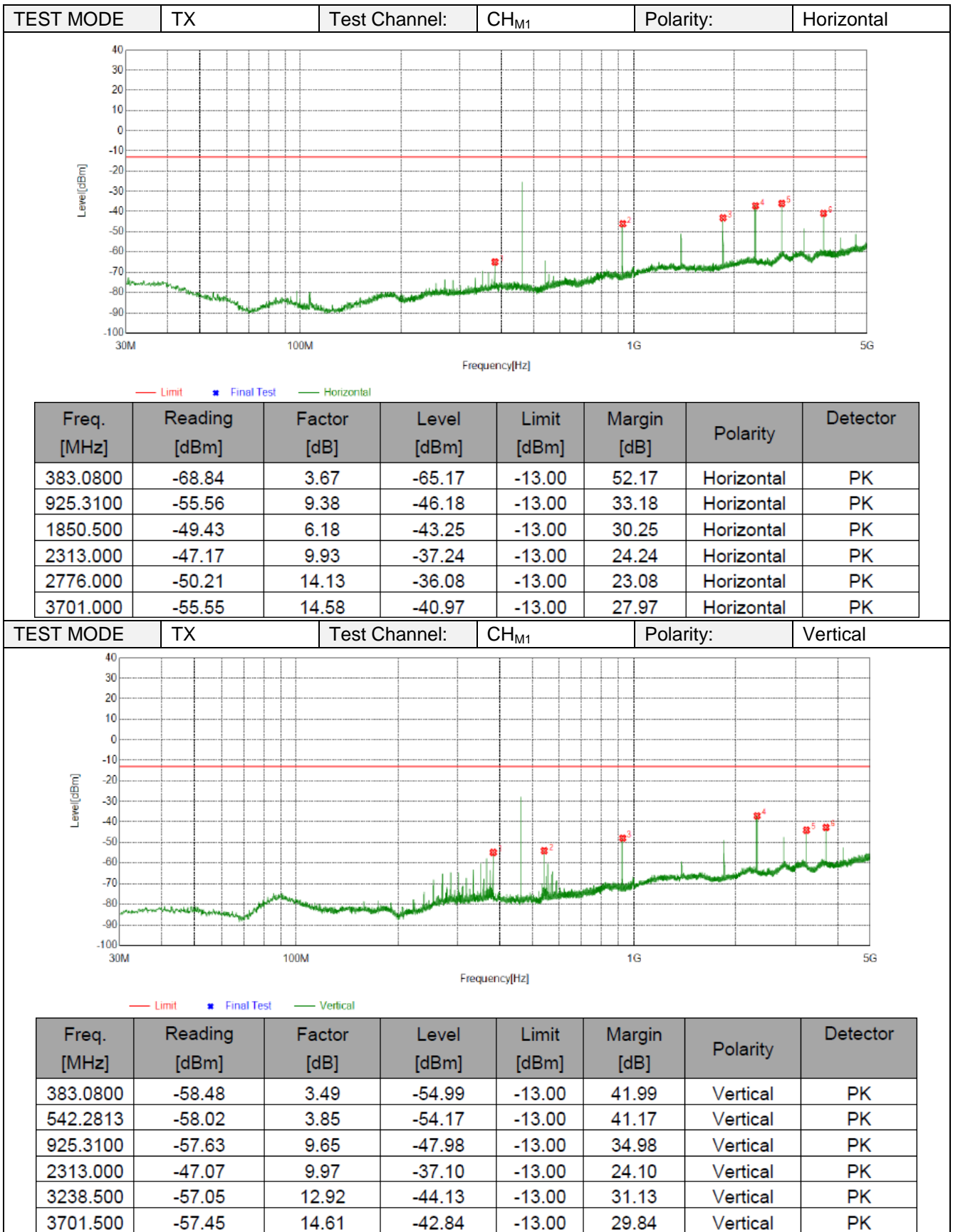

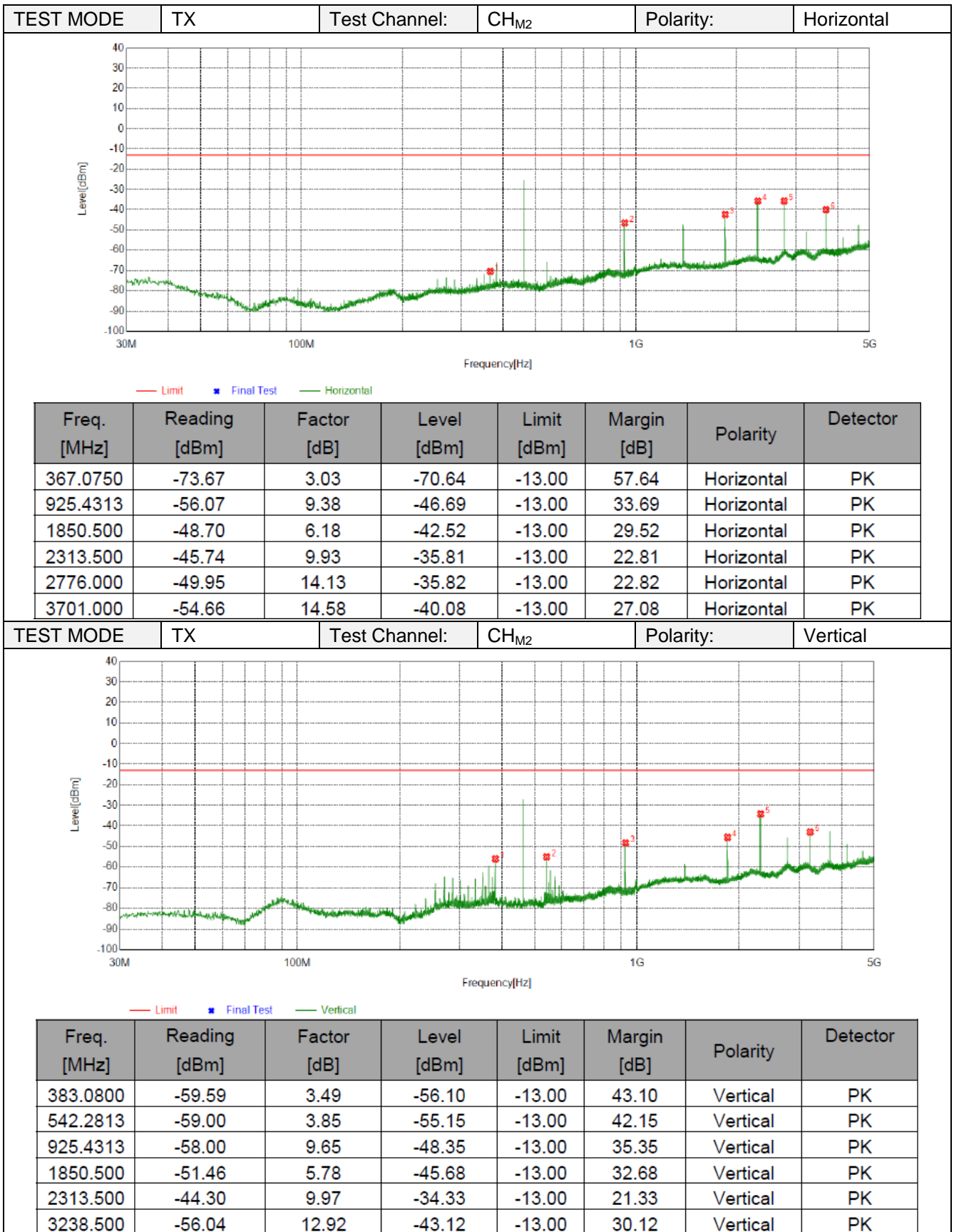



### 5.9. AC Power Line Conducted Emission

The frequency spectrum from 0.15 MHz to 30 MHz was investigated. The LISN used was 50 ohm / 50 u Henry as specified by section 5.1 of ANSI C63.4. Cables and peripherals were moved to find the maximum emission levels for each frequency.

#### Limit

#### FCC part 15.107(a)

Frequency of emission (MHz)	Conducted limit (dBµV)	
	Quasi-peak	Average
0.15-0.5	66 to 56*	56 to 46*
0.5-5	56	46
5-30	60	50

#### TEST CONFIGURATION

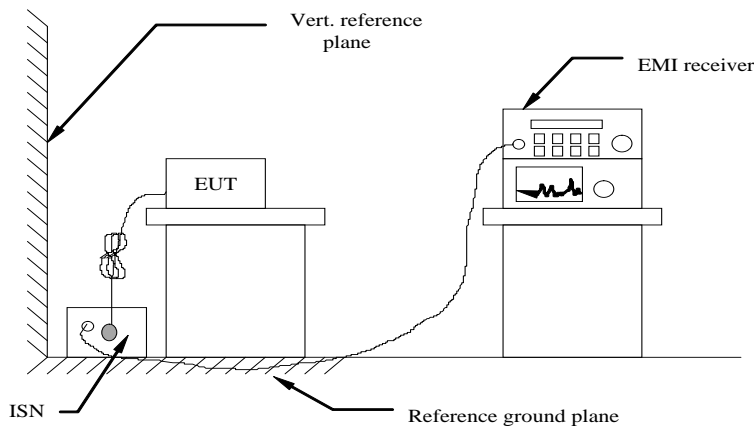

#### TEST PROCEDURE

- 1 The equipment was set up as per the test configuration to simulate typical actual usage per the user’s manual. The EUT is a tabletop system; a wooden table with a height of 0.8 meters is used and is placed on the ground plane as per ANSI C63.4
- 2 Support equipment, if needed, was placed as per ANSI C63.4
- 3 All I/O cables were positioned to simulate typical actual usage as per ANSI C63.4.
- 4 If a EUT received AC120V/60Hz power through a Line Impedance Stabilization Network (LISN) which supplied power source and was grounded to the ground plane.
- 5 All support equipments received AC power from a second LISN, if any
- 6 The EUT test program was started. Emissions were measured on each current carrying line of the EUT using a spectrum Analyzer / Receiver connected to the LISN powering the EUT. The LISN has two monitoring points: Line 1 (Hot Side) and Line 2 (Neutral Side). Two scans were taken: one with Line 1 connected to Analyzer / Receiver and Line 2 connected to a 50 ohm load; the second scan had Line 1 connected to a 50 ohm load and Line 2 connected to the Analyzer / Receiver.
- 7 Analyzer / Receiver scanned from 150 kHz to 30MHz for emissions in each of the test modes.
- 8 During the above scans, the emissions were maximized by cable manipulation.

#### TEST MODE

Please reference to the section 3.4

#### TEST RESULTS

Passed       Not Applicable

Polarity:

L

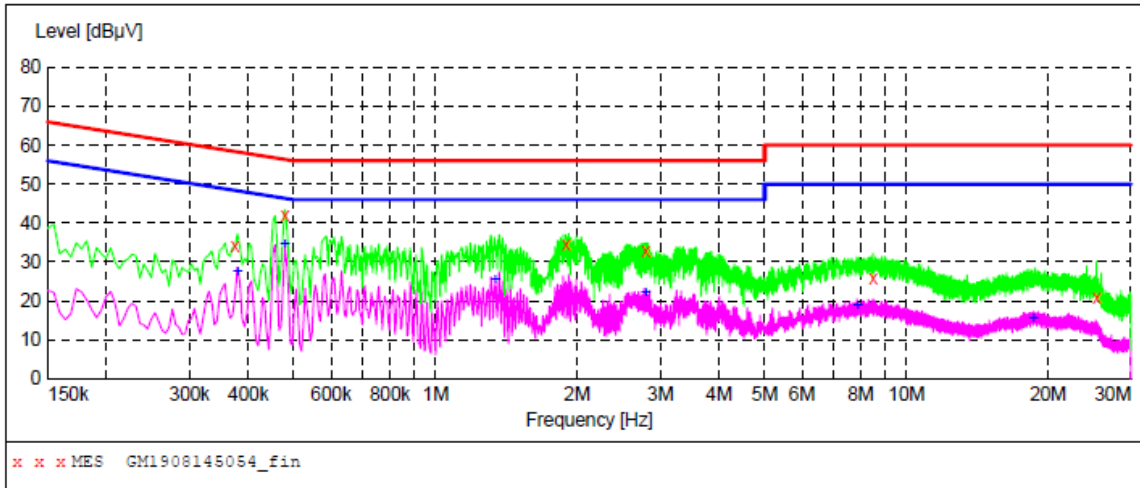

**MEASUREMENT RESULT: "GM1908145054\_fin"**

8/14/2019 4:31PM

Frequency MHz	Level dBµV	Transd dB	Limit dBµV	Margin dB	Detector	Line	PE
0.375000	34.20	9.9	58	24.2	QP	L1	GND
0.478500	42.10	9.9	56	14.3	QP	L1	GND
1.891500	34.50	9.9	56	21.5	QP	L1	GND
2.791500	33.00	9.9	56	23.0	QP	L1	GND
8.493000	26.00	10.1	60	34.0	QP	L1	GND
25.368000	21.00	10.3	60	39.0	QP	L1	GND

**MEASUREMENT RESULT: "GM1908145054\_fin2"**

8/14/2019 4:31PM

Frequency MHz	Level dBµV	Transd dB	Limit dBµV	Margin dB	Detector	Line	PE
0.379500	27.50	9.9	48	20.8	AV	L1	GND
0.478500	34.50	9.9	46	11.9	AV	L1	GND
1.338000	25.40	9.9	46	20.6	AV	L1	GND
2.796000	22.00	9.9	46	24.0	AV	L1	GND
7.872000	18.60	10.0	50	31.4	AV	L1	GND
18.600000	15.60	10.2	50	34.4	AV	L1	GND



Polarity:

N

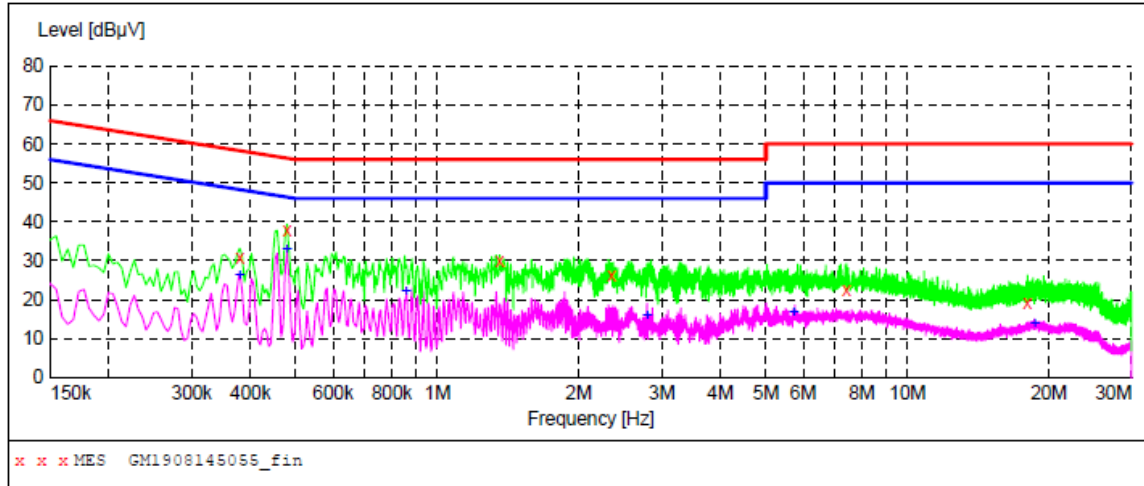

**MEASUREMENT RESULT: "GM1908145055\_fin"**

8/14/2019 4:34PM

Frequency MHz	Level dBµV	Transd dB	Limit dBµV	Margin dB	Detector	Line	PE
0.379500	30.70	9.9	58	27.6	QP	N	GND
0.478500	38.00	9.9	56	18.4	QP	N	GND
1.356000	29.80	9.9	56	26.2	QP	N	GND
2.341500	26.40	9.9	56	29.6	QP	N	GND
7.413000	22.40	10.0	60	37.6	QP	N	GND
18.006000	19.00	10.2	60	41.0	QP	N	GND

**MEASUREMENT RESULT: "GM1908145055\_fin2"**

8/14/2019 4:34PM

Frequency MHz	Level dBµV	Transd dB	Limit dBµV	Margin dB	Detector	Line	PE
0.379500	26.40	9.9	48	21.9	AV	N	GND
0.478500	32.70	9.9	46	13.7	AV	N	GND
0.856500	22.00	9.9	46	24.0	AV	N	GND
2.791500	16.00	9.9	46	30.0	AV	N	GND
5.730000	16.80	10.0	50	33.2	AV	N	GND
18.667500	13.60	10.2	50	36.4	AV	N	GND

### 5.10 Radiated Emission

#### LIMIT

For unintentional device, according to § 15.109(a) except for Class A digital devices, the field strength of radiated emissions from unintentional radiators at a distance of 3 meters shall not exceed the following values:

Frequency of emission (MHz)	Field strength (microvolts/meter)
30-88	100
88-216	150
216-960	200
Above 960	500

For intentional device, according to § 15.209(a), the general requirement of field strength of radiated emissions from intentional radiators at a distance of 3 meters shall not exceed the above table.

#### TEST CONFIGURATION

(A) Radiated Emission Test Set-Up, Frequency below 1000MHz

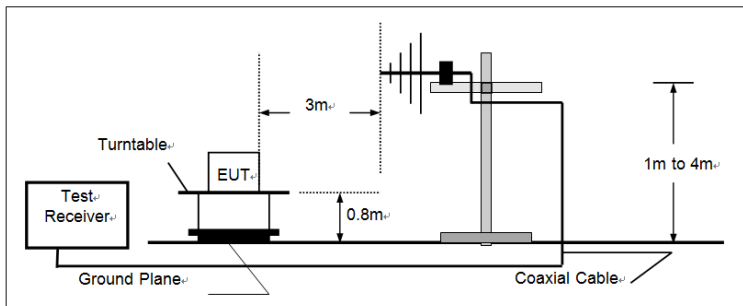

(B) Radiated Emission Test Set-Up, Frequency above 1000MHz

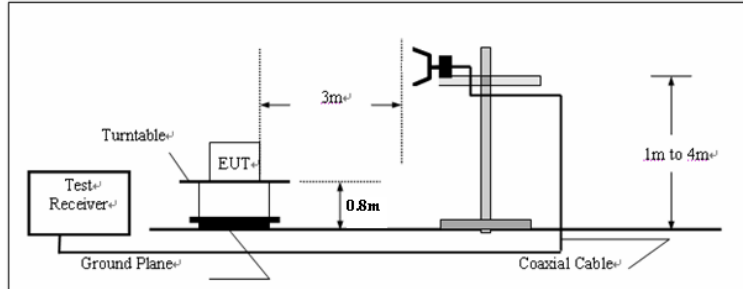

#### TEST PROCEDURE

- 1 The EUT was placed on a turn table which is 0.8m above ground plane.
- 2 Maximum procedure was performed by raising the receiving antenna from 1m to 4m and rotating the turn table from 0°C to 360°C to acquire the highest emissions from EUT
- 3 And also, each emission was to be maximized by changing the polarization of receiving antenna both horizontal and vertical.
- 4 Repeat above procedures until all frequency measurements have been completed.

#### TEST MODE

Please reference to the section 3.4

#### TEST RESULTS

Passed       Not Applicable

Note:

The EUT shall be scanned from 30 MHz to the 5th harmonic of the highest oscillator frequency in the digital devices or 1 GHz whichever is higher.

Polarity:

Horizontal

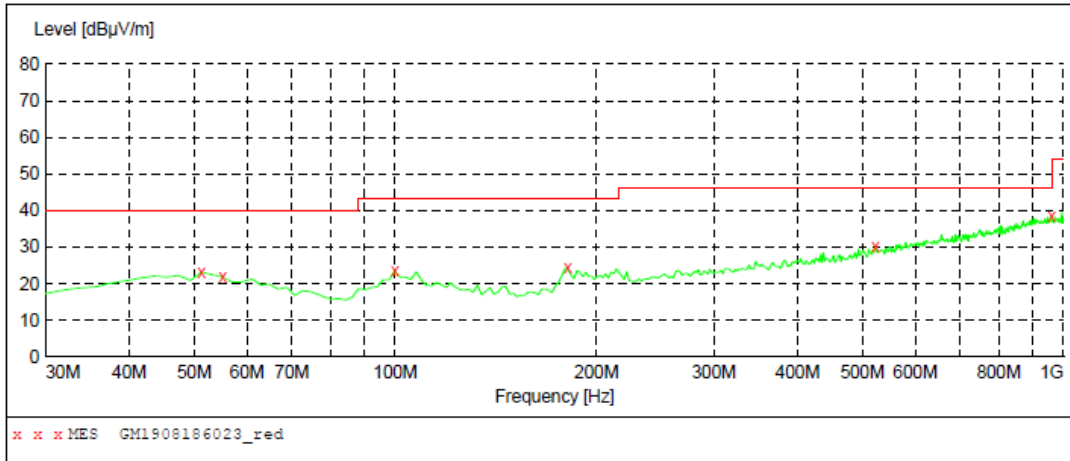

**MEASUREMENT RESULT: "GM1908186023\_red"**

8/18/2019 11:14AM

Frequency MHz	Level dBµV/m	Transd dB	Limit dBµV/m	Margin dB	Det.	Height cm	Azimuth deg	Polarization
51.340000	23.20	-4.9	40.0	16.8	QP	100.0	130.00	HORIZONTAL
55.220000	21.90	-5.3	40.0	18.1	QP	100.0	281.00	HORIZONTAL
99.840000	23.50	-6.7	43.5	20.0	QP	300.0	174.00	HORIZONTAL
181.320000	24.20	-8.3	43.5	19.3	QP	100.0	118.00	HORIZONTAL
522.760000	30.30	2.5	46.0	15.7	QP	100.0	270.00	HORIZONTAL
959.260000	38.40	10.9	46.0	7.6	QP	300.0	150.00	HORIZONTAL

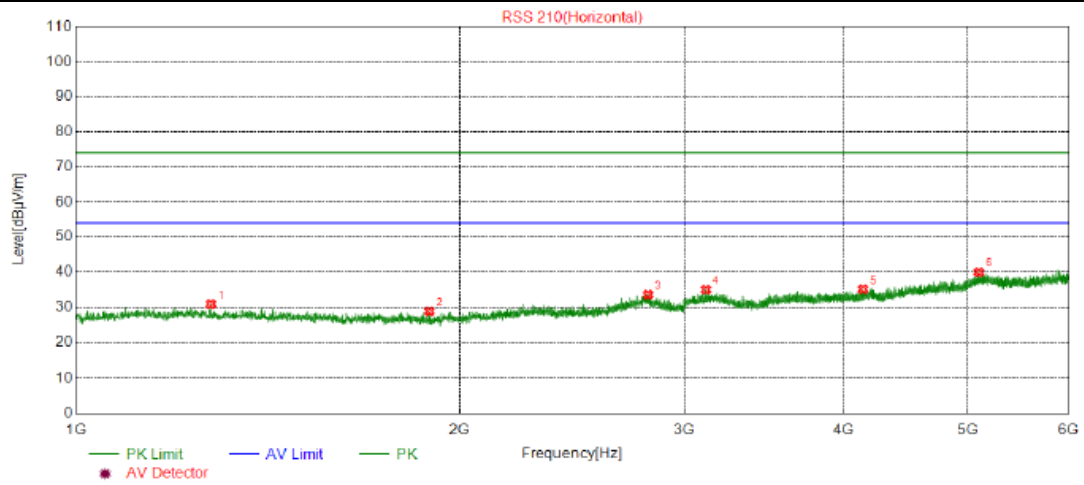

Suspected Data List								
NO.	Freq. [MHz]	Reading [dBµV/m]	Factor [dB]	Level [dBµV/m]	Limit [dBµV/m]	Margin [dB]	Polarity	Detector
1	1276.250	36.50	-5.63	30.87	74.00	43.13	Horizontal	PK
2	1893.125	34.62	-5.83	28.79	74.00	45.21	Horizontal	PK
3	2808.125	31.58	1.96	33.54	74.00	40.46	Horizontal	PK
4	3118.750	34.56	0.42	34.98	74.00	39.02	Horizontal	PK
5	4141.250	31.61	3.49	35.10	74.00	38.90	Horizontal	PK
6	5104.375	31.18	8.81	39.99	74.00	34.01	Horizontal	PK

Polarity: Vertical

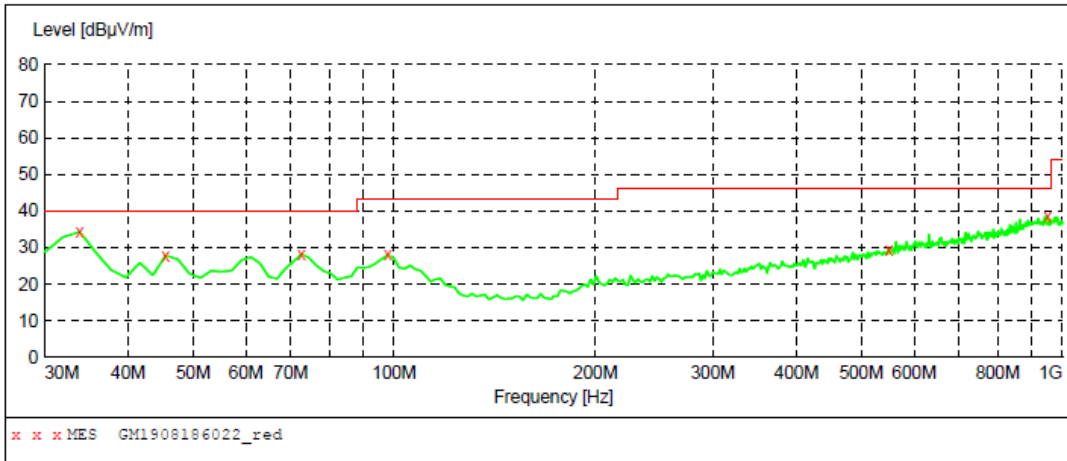

**MEASUREMENT RESULT: "GM1908186022\_red"**

8/18/2019 11:09AM

Frequency MHz	Level dBµV/m	Transd dB	Limit dBµV/m	Margin dB	Det.	Height cm	Azimuth deg	Polarization
33.880000	34.30	-8.7	40.0	5.7	QP	100.0	129.00	VERTICAL
45.520000	27.90	-4.9	40.0	12.1	QP	100.0	350.00	VERTICAL
72.680000	28.20	-10.2	40.0	11.8	QP	100.0	157.00	VERTICAL
97.900000	28.00	-6.9	43.5	15.5	QP	100.0	88.00	VERTICAL
549.920000	29.60	3.0	46.0	16.4	QP	100.0	251.00	VERTICAL
949.560000	38.50	10.8	46.0	7.5	QP	100.0	170.00	VERTICAL

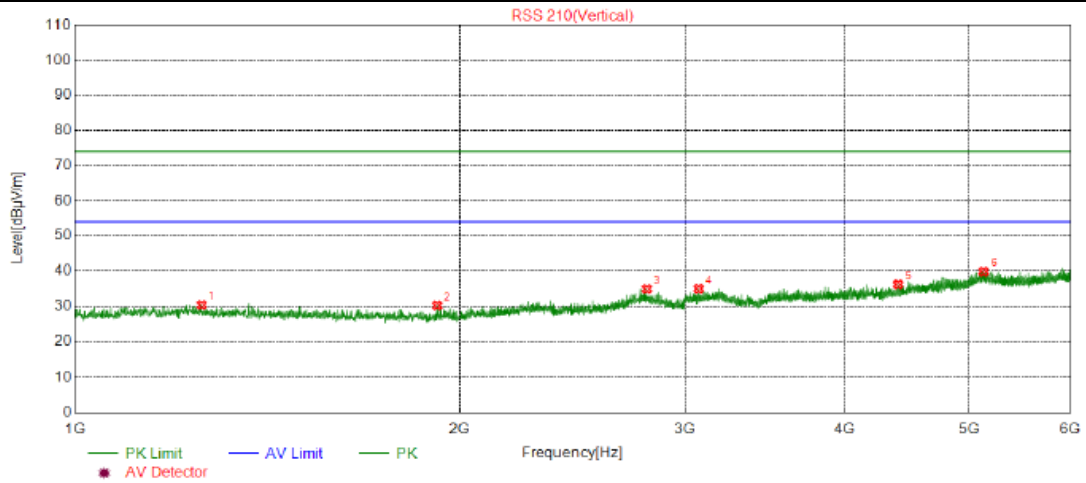

Suspected Data List								
NO.	Freq. [MHz]	Reading [dBµV/m]	Factor [dB]	Level [dBµV/m]	Limit [dBµV/m]	Margin [dB]	Polarity	Detector
1	1256.250	35.98	-5.68	30.30	74.00	43.70	Vertical	PK
2	1920.000	35.75	-5.60	30.15	74.00	43.85	Vertical	PK
3	2800.000	32.78	2.09	34.87	74.00	39.13	Vertical	PK
4	3074.375	34.72	0.21	34.93	74.00	39.07	Vertical	PK
5	4403.750	31.20	4.94	36.14	74.00	37.86	Vertical	PK
6	5133.750	30.96	8.86	39.82	74.00	34.18	Vertical	PK

## 6. Test Setup Photos of the EUT

Transmitter Radiated Spurious Emission:



Frequency stability:



AC Power Line Conducted Emission:





Radiated Emission:

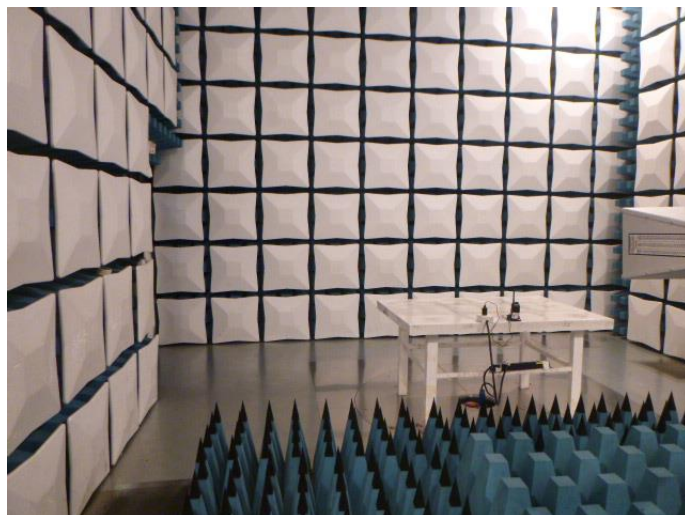

## 7. External and Internal Photos of the EUT

### External Photos of the EUT

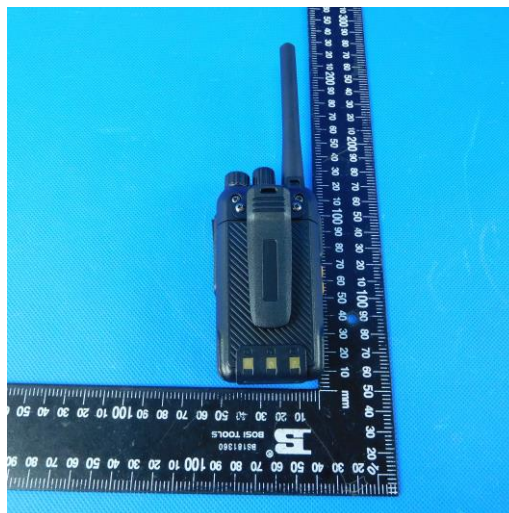
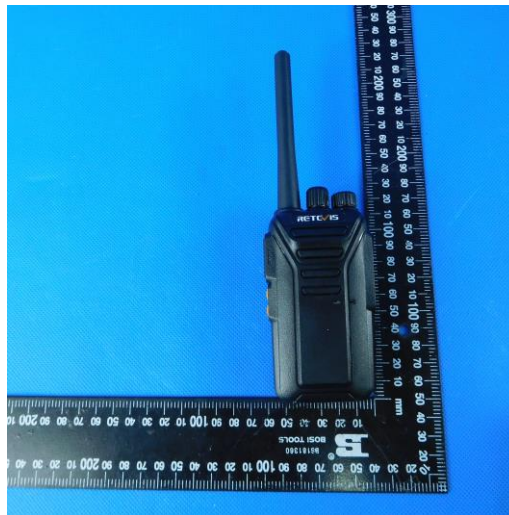

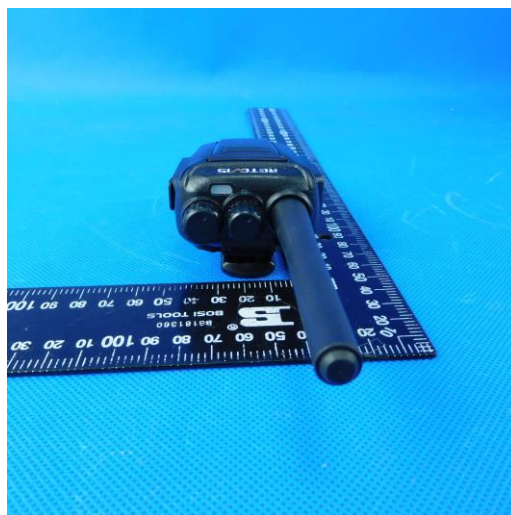
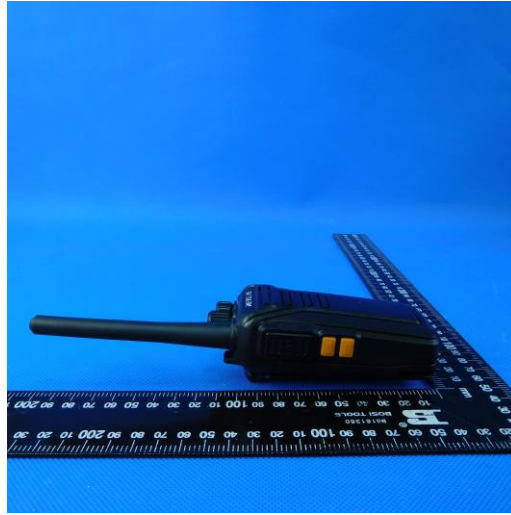



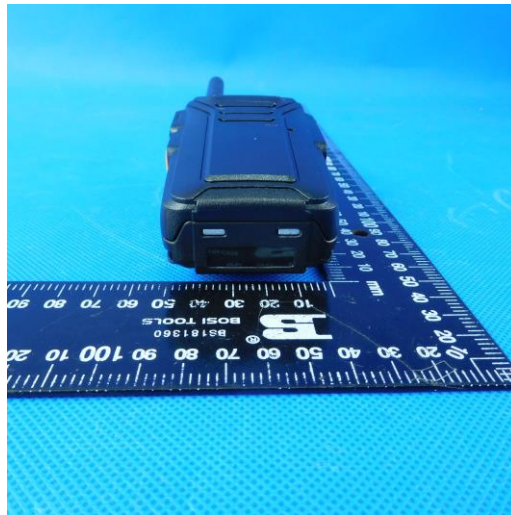



### Internal Photos of the EUT

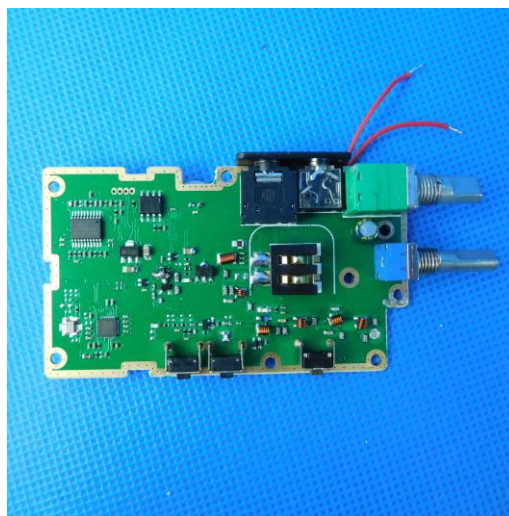
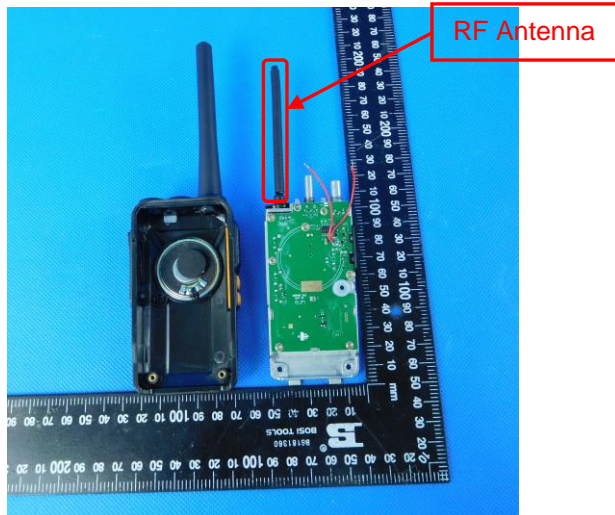

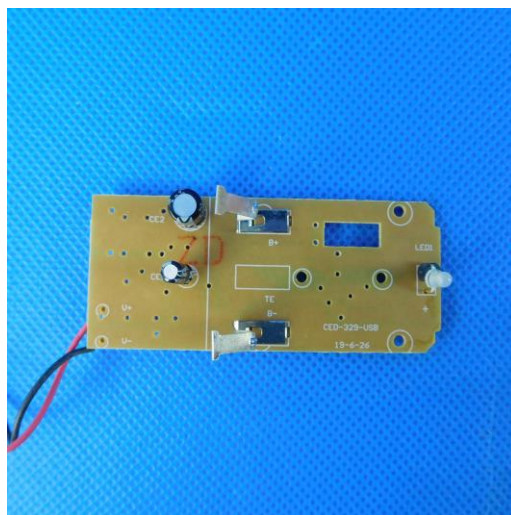
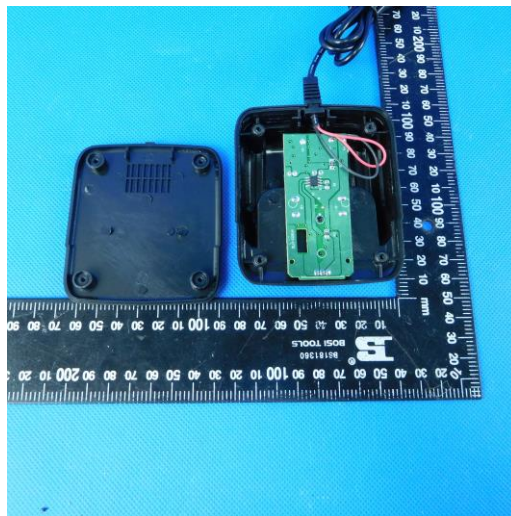
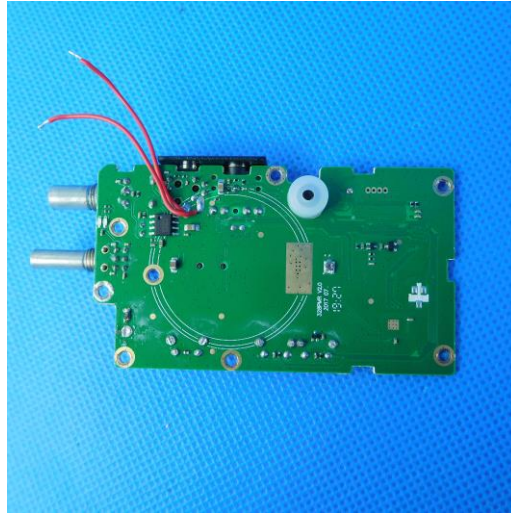



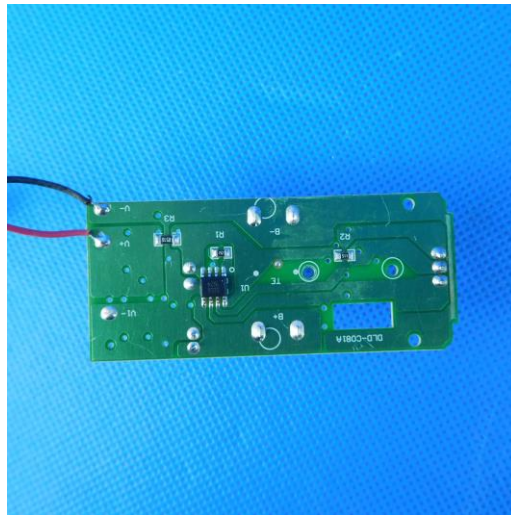

## 8. APPENDIX REPORT



**Appendix A: Carrier Output Power(ERP)**

Test Mode	Modulation Type	Test Channel	Measured power (dBm)	Measured power (W)	Limit(W)	Result
TX	FM	CH <sub>M1</sub>	25.72	0.37	≤2	PASS
TX	FM	CH <sub>H</sub>	25.34	0.34	≤2	PASS

**Appendix B: 99% Occupied Bandwidth & 26dB Bandwidth**

Test Mode	Modulation Type	Test Channel	Occupied Bandwidth		99% Limit(kHz)	Result
			99%(kHz)	26dB(kHz)		
TX	FM	CH <sub>M1</sub>	9.96	10.16	≤ 11.25	PASS
TX	FM	CH <sub>H</sub>	<b><u>14.776</u></b>	15.62	≤ 20	PASS

**Appendix B: 99% Occupied Bandwidth & 26dB Bandwidth**



**Appendix B: 99% Occupied Bandwidth & 26dB Bandwidth**

Test Mode	Modulation Type	Test Channel	TEST PLOT RESULT
TX	FM	CH <sub>M1</sub>	<p>Agilent Spectrum Analyzer - Occupied BW</p> <p>Center Freq 151.880000 MHz</p> <p>Ref 29.67 dBm</p> <p>Occupied Bandwidth: 9.960 kHz</p> <p>Total Power: 25.7 dBm</p> <p>Transmit Freq Error: -47 Hz</p> <p>x dB Bandwidth: 10.16 kHz</p> <p>OBW Power: 99.00 %</p> <p>x dB: -26.00 dB</p>
TX	FM	CH <sub>H</sub>	<p>Agilent Spectrum Analyzer - Occupied BW</p> <p>Center Freq 154.600000 MHz</p> <p>Ref 29.39 dBm</p> <p>Occupied Bandwidth: 14.776 kHz</p> <p>Total Power: 26.4 dBm</p> <p>Transmit Freq Error: -50 Hz</p> <p>x dB Bandwidth: 15.62 kHz</p> <p>OBW Power: 99.00 %</p> <p>x dB: -26.00 dB</p>





Appendix C:Emission Mask

Test Mode	Modulation Type	Test Channel	TEST PLOT RESULT
TX	FM	CH <sub>M1</sub>	<p>MultiView Spectrum Ref Level 30.00 dBm Att 40 dB SWT 41.9 ms (-55 ms) RBW 100 Hz VBW 300 Hz Mode Auto FFT 1 Frequency Sweep 20 dBm 10 dBm 0 dBm -10 dBm -20 dBm -30 dBm -40 dBm -50 dBm -60 dBm CF 151.88 MHz 1001 pts 5.0 kHz/pt Span 50.0 kHz Measuring... 23/03/2019 13:54:43 Date: 23/03/2019 13:54:43</p>
TX	FM	CH <sub>H</sub>	<p>MultiView Spectrum Ref Level 30.00 dBm Att 40 dB SWT 41.9 ms (-57 ms) RBW 100 Hz VBW 300 Hz Mode Auto FFT 1 Frequency Sweep 20 dBm 10 dBm 0 dBm -10 dBm -20 dBm -30 dBm -40 dBm -50 dBm -60 dBm CF 154.6 MHz 1001 pts 10.0 kHz/pt Span 100.0 kHz Measuring... 23/03/2019 14:02:38 Date: 23/03/2019 14:02:38</p>

**Appendix D:Audio Low Pass Filter Response**

Test Mode	Modulation Type	Test Channel	Frequency (KHz)	dB relative to 1 KHz	Limit	Result
TX	FM	CH <sub>M1</sub>	1	-16.76	0.00	PASS
TX	FM	CH <sub>M1</sub>	3	-26.27	0.00	PASS
TX	FM	CH <sub>M1</sub>	4	-53.16	-7.50	PASS
TX	FM	CH <sub>M1</sub>	5	-53.23	-13.30	PASS
TX	FM	CH <sub>M1</sub>	6	-54.10	-18.10	PASS
TX	FM	CH <sub>M1</sub>	8	-53.26	-25.60	PASS
TX	FM	CH <sub>M1</sub>	10	-53.28	-31.40	PASS
TX	FM	CH <sub>M1</sub>	15	-53.52	-41.90	PASS
TX	FM	CH <sub>M1</sub>	20	-53.56	-50.00	PASS
TX	FM	CH <sub>M1</sub>	30	-54.12	-50.00	PASS
TX	FM	CH <sub>M1</sub>	40	-53.22	-50.00	PASS
TX	FM	CH <sub>M1</sub>	50	-53.23	-50.00	PASS
TX	FM	CH <sub>M1</sub>	60	-53.68	-50.00	PASS
TX	FM	CH <sub>M1</sub>	70	-54.22	-50.00	PASS
TX	FM	CH <sub>M1</sub>	80	-54.23	-50.00	PASS
TX	FM	CH <sub>M1</sub>	90	-54.25	-50.00	PASS
TX	FM	CH <sub>M1</sub>	100	-53.26	-50.00	PASS
TX	FM	CH <sub>H</sub>	1	-16.71	0.00	PASS
TX	FM	CH <sub>H</sub>	3	-26.26	0.00	PASS
TX	FM	CH <sub>H</sub>	4	-58.27	-7.50	PASS
TX	FM	CH <sub>H</sub>	5	-58.53	-13.30	PASS
TX	FM	CH <sub>H</sub>	6	-59.62	-18.10	PASS
TX	FM	CH <sub>H</sub>	8	-58.71	-25.60	PASS
TX	FM	CH <sub>H</sub>	10	-59.26	-31.40	PASS
TX	FM	CH <sub>H</sub>	15	-59.55	-41.90	PASS
TX	FM	CH <sub>H</sub>	20	-59.62	-50.00	PASS
TX	FM	CH <sub>H</sub>	30	-59.77	-50.00	PASS
TX	FM	CH <sub>H</sub>	40	-60.10	-50.00	PASS
TX	FM	CH <sub>H</sub>	50	-59.88	-50.00	PASS
TX	FM	CH <sub>H</sub>	60	-59.63	-50.00	PASS
TX	FM	CH <sub>H</sub>	70	-59.89	-50.00	PASS
TX	FM	CH <sub>H</sub>	80	-60.11	-50.00	PASS
TX	FM	CH <sub>H</sub>	90	-60.08	-50.00	PASS
TX	FM	CH <sub>H</sub>	100	-60.23	-50.00	PASS



### Appendix D:Audio Low Pass Filter Response

Test Mode	Modulation Type	Test Channel	TEST PLOT RESULT
TX	FM	CH <sub>M1</sub>	<p>dB relative to 1 KHz</p> <p>FREQUENCY (KHz)</p> <p>dB relative to 1 KHz</p>
TX	FM	CH <sub>H</sub>	<p>dB relative to 1 KHz</p> <p>FREQUENCY (KHz)</p> <p>dB relative to 1 KHz</p>

**Appendix E:Frequency Stability Test & Temperature**

Test Mode	Modulation Type	Test Conditions		Frequency error (ppm)		Limit (ppm)	Result
		Voltage	Temperature	CH <sub>M1</sub>	CH <sub>H</sub>		
TX	FM	V <sub>N</sub>	-30	-0.286	-0.252	±5	PASS
TX	FM	V <sub>N</sub>	-20	-0.280	-0.259	±5	PASS
TX	FM	V <sub>N</sub>	-10	-0.286	-0.270	±5	PASS
TX	FM	V <sub>N</sub>	0	-0.292	-0.266	±5	PASS
TX	FM	V <sub>N</sub>	10	-0.293	-0.254	±5	PASS
TX	FM	V <sub>N</sub>	20	-0.276	<u><b>-0.251</b></u>	±5	PASS
TX	FM	V <sub>N</sub>	30	-0.278	-0.259	±5	PASS
TX	FM	V <sub>N</sub>	40	-0.289	-0.257	±5	PASS
TX	FM	V <sub>N</sub>	55	-0.280	-0.265	±5	PASS



**Appendix F:Frequency Stability Test & Voltage**

Test Mode	Modulation Type	Test Conditions		Frequency error (ppm)		Limit (ppm)	Result
		Voltage	Temperature	CH <sub>M1</sub>	CH <sub>H</sub>		
TX	FM	V <sub>N</sub>	T <sub>N</sub>	-0.276	<u><b>-0.251</b></u>	±5	PASS
TX	FM	V <sub>L</sub>	T <sub>N</sub>	-0.277	-0.256	±5	PASS
TX	FM	V <sub>H</sub>	T <sub>N</sub>	-0.283	-0.259	±5	PASS

----End of Report----



**Appendix G:Transmitter Spurious Emssion on antenna port**

Test Mode	Modulation Type	Test Channel	TEST PLOT RESULT
TX	FM	CH <sub>M1</sub>	
TX	FM	CH <sub>H</sub>	