

DFS TEST REPORT

Applicant: Neusoft Corporation

Address of Applicant: No.2 Xinxiu Street, Hunnan New District, Shenyang, Liaoning, China Shenyang Liaoning CN 110179

Equipment Under Test (EUT)

Product Name: Wireless Digital Terminal

Model No.: S611G

Trade mark: Neusoft

FCC ID: 2ASMA-S611G

Applicable standards: FCC CFR Title 47 Part 15 Subpart E Section 15.407

Date of sample receipt: 17 Sep., 2019

Date of Test: 18 Sep., to 15 Oct., 2019

Date of report issued: 13 Nov., 2019

Test Result: PASS*

*In the configuration tested, the EUT complied with the standards specified above.

Authorized Signature:



Bruce Zhang

Laboratory Manager

This report details the results of the testing carried out on one sample. The results contained in this test report do not relate to other samples of the same product and does not permit the use of the CCIS product certification mark. The manufacturer should ensure that all products in series production are in conformity with the product sample detailed in this report.

This report may only be reproduced and distributed in full. If the product in this report is used in any configuration other than that detailed in the report, the manufacturer must ensure the new system complies with all relevant standards.

This document cannot be reproduced except in full, without prior written approval of the Company. Any unauthorized alteration, forgery or falsification of the content or appearance of this document is unlawful and offenders may be prosecuted to the fullest extent of the law. Unless otherwise stated the results shown in this test report refer only to the sample(s) tested and such sample(s) are retained for 90 days only.

2 Version

| Version No. | Date | Description |
|-------------|---------------|---------------|
| 00 | 16 Oct., 2019 | Original |
| 01 | 13 Nov., 2019 | Update page 5 |
| | | |
| | | |
| | | |

Tested by:

Mike.ou

Date:

13 Nov., 2019

Test Engineer

Reviewed by:

Winner Zhang

Date:

13 Nov., 2019

Project Engineer

3 Contents

| | Page |
|---|------|
| 1 COVER PAGE..... | 1 |
| 2 VERSION | 2 |
| 3 CONTENTS | 3 |
| 4 TEST SUMMARY..... | 4 |
| 5 GENERAL INFORMATION..... | 5 |
| 5.1 CLIENT INFORMATION | 5 |
| 5.2 GENERAL DESCRIPTION OF E.U.T. | 5 |
| 5.3 TEST ENVIRONMENT AND TEST MODE | 5 |
| 5.4 DESCRIPTION OF SUPPORT UNITS..... | 5 |
| 5.5 RELATED SUBMITTAL(S) / GRANT (S) | 5 |
| 5.6 ADDITIONS TO, DEVIATIONS, OR EXCLUSIONS FROM THE METHOD | 5 |
| 5.7 LABORATORY FACILITY | 6 |
| 5.8 LABORATORY LOCATION | 6 |
| 5.9 TEST INSTRUMENTS LIST..... | 6 |
| 6 DFS TECHNICAL REQUIREMENTS..... | 7 |
| 6.1 DFS PARAMETERS | 7 |
| 6.2 DFS TECHNICAL REQUIREMENTS | 9 |
| 6.3 DFS THRESHOLD LEVEL | 9 |
| 6.4 TEST SETUP BLOCK..... | 9 |
| 6.5 EUT CONFIGURATION FOR DFS TEST..... | 10 |
| 7 TEST RESULT | 11 |
| 7.1 VERIFICATION OF RADAR TYPE AND LEVEL..... | 11 |
| 7.2 CHANNEL MOVE TIME AND CHANNEL CLOSING TRANSMISSION TIME..... | 12 |
| 8 TEST SETUP PHOTO | 13 |
| 9 EUT CONSTRUCTIONAL DETAILS | 13 |

4 Test Summary

| Test Items | Limit | Result |
|---|---|--------|
| Channel Availability Check | > 60 seconds | N/A |
| UNII Detection Bandwidth | > 100% of the UNII 99% transmission power bandwidth | N/A |
| Statistical Performance Check | Radar type 1,2,3,4 \geq 60% Aggregate Radar type 1~4 and 5 \geq 80% Radar type 6 \geq 70% | N/A |
| Channel Move Time | < 10 seconds | Pass |
| Channel Closing Transmission Time | < 20ms + aggregate of 60ms over remaining 10 second period | Pass |
| Non-Occupancy Period | > 30 minutes | N/A |
| <p>Remark:</p> <ol style="list-style-type: none"> 1. Pass: means meet the requirements. 2. N/A: means not applicable. 3. The cable insertion loss used by "RF Output Power" and other conduction measurement items is 0.5dB (provided by the customer). | | |
| Test Method: | ANSI C63.4-2014 ANSI C63.10-2013 KDB 789033 D02 General UNII Test Procedures New Rules v02r01 | |

5 General Information

5.1 Client Information

| | |
|---------------|--|
| Applicant: | Neusoft Corporation |
| Address: | No.2 Xinxu Street, Hunnan New District, Shenyang, Liaoning, China Shenyang Liaoning CN 110179 |
| Manufacturer: | Neusoft Corporation |
| Address: | No.2 Xinxu Street, Hunnan New District, Shenyang, Liaoning, China Shenyang Liaoning CN 110179 |

5.2 General Description of E.U.T.

| | |
|------------------------------|--|
| Product Name: | Wireless Digital Terminal |
| Model No.: | S611G |
| Transmitter frequency range: | 5150MHz~5250MHz, 5250MHz~5350MHz 5470MHz~5725MHz, 5725MHz~5825MHz |
| Modulation type: | OFDM |
| WLAN Function: | 802.11a/802.11n/802.11ac |
| Bandwidth: | 20MHz/40MHz/80MHz |
| Antenna Type: | Internal Antenna |
| Antenna Gain: | 0.9 dBi |
| TPC Power: | Not support |
| DFS Operation Type: | <input type="checkbox"/> Master Device <input type="checkbox"/> Slaver Device with Radar detection function <input checked="" type="checkbox"/> Slaver Device without Radar detection function |
| Power supply: | Rechargeable Lithium polymer Battery DC3.85V-4600mAh |
| AC adapter: | Model: ICP12-050-2000B Input: AC100-240V, 50/60Hz, 0.3A Output: DC 5.0V, 2000mA |
| Test Sample Condition: | The test samples were provided in good working order with no visible defects. |

5.3 Test Environment and test mode

| | |
|-----------------------|--|
| Data Load mode: | Keep the EUT in normal transmitting mode by WiFi |
| Temperature: | 20 ~ 25 °C |
| Humidity: | 60% ~ 65% |
| Atmospheric pressure: | 1012 kPa |

5.4 Description of Support Units

| Manufacturer | Description | Model | Serial Number |
|--------------|-------------|------------|---------------|
| LENOVO | Laptop | SL510 | 2847A65 |
| WAVLINK | WiFi Router | WL-WN575A2 | WL1512260097 |

5.5 Related Submittal(s) / Grant (s)

| |
|--|
| This is an original grant, no related submittals and grants. |
|--|

5.6 Additions to, deviations, or exclusions from the method

| |
|----|
| No |
|----|

5.7 Laboratory Facility

The test facility is recognized, certified, or accredited by the following organizations:

- **FCC - Designation No.: CN1211**

Shenzhen Zhongjian Nanfang Testing Co., Ltd. has been accredited as a testing laboratory by FCC(Federal Communications Commission). The test firm Registration No. is 727551.

- **ISED – CAB identifier.: CN0021**

The 3m Semi-anechoic chamber of Shenzhen Zhongjian Nanfang Testing Co., Ltd. has been Registered by Certification and Engineering Bureau of Industry Canada for radio equipment testing with Registration No.: 10106A-1.

- **CNAS - Registration No.: CNAS L6048**

Shenzhen Zhongjian Nanfang Testing Co., Ltd. is accredited to ISO/IEC 17025:2005 General Requirements for the Competence of Testing and Calibration laboratories for the competence of testing. The Registration No. is CNAS L6048.

- **A2LA - Registration No.: 4346.01**

This laboratory is accredited in accordance with the recognized International Standard ISO/IEC 17025:2005 General requirements for the competence of testing and calibration laboratories. The test scope can be found as below link: <https://portal.a2la.org/scopepdf/4346-01.pdf>

5.8 Laboratory Location

Shenzhen Zhongjian Nanfang Testing Co., Ltd.

Address: No. B-C, 1/F., Building 2, Laodong No.2 Industrial Park, Xixiang Road, Bao'an District, Shenzhen, Guangdong, China

Tel: +86-755-23118282, Fax: +86-755-23116366

Email: info@ccis-cb.com, Website: http://www.ccis-cb.com

5.9 Test Instruments list

| Test Equipment | Manufacturer | Model No. | Serial No. | Cal. Due date (mm-dd-yy) | Cal. Due date (mm-dd-yy) |
|-------------------------|--------------|-----------|------------------|--------------------------|--------------------------|
| Spectrum Analyzer | Agilent | N9020A | MY50510123 | 11-10-2019 | 11-09-2020 |
| Vector Signal Generator | Agilent | N5182A | MY49060014 | 11-10-2019 | 11-09-2020 |
| RF Switch Unit | Ascentest | AT890-RFB | -- | -- | -- |
| DFS Test Software | MWRFTST | MTS 8310 | Version: 2.0.0.0 | | |
| N7607B Signal Studio | KEYSIGHT | -- | Version: 2.0.0.1 | | |

6 DFS Technical Requirements

6.1 DFS Parameters

| Table D.1: Applicability of DFS Requirements Prior to Use of a Channel | | | |
|--|------------------|--------------------------------|-----------------------------|
| Requirement | Operational Mode | | |
| | Master | Client Without Radar Detection | Client With Radar Detection |
| Non-Occupancy period | Yes | Not required | Yes |
| DFS Detection Threshold | Yes | Not required | Yes |
| Channel Availability Check Time | Yes | Not required | Not required |
| U-NII Detection Bandwidth | Yes | Not required | Yes |

| Table D.2: Applicability of DFS requirements during normal operation | | |
|--|------------------|--------------------------------|
| Requirement | Operational Mode | |
| | Master | Client Without Radar Detection |
| DFS Detection Threshold | Yes | Not required |
| Channel Closing Transmission Time | Yes | Yes |
| Channel Move Time | Yes | Yes |
| U-NII Detection Bandwidth | Yes | Not required |

| Additional requirements for devices with multiple bandwidth modes | Operational Mode | |
|---|--|--|
| | Master Device or Client with Radar Detection | Client Without Radar Detection |
| U-NII Detection Bandwidth and Statistical Performance Check | All BW modes must be tested | Not required |
| Channel Move Time and Channel Closing Transmission Time | Test using widest BW mode available | Test using the widest BW mode available for the link |
| All other tests | Any single BW mode | Not required |

Note: Frequencies selected for statistical performance check (Section 7.8.4) should include several frequencies within the radar detection bandwidth and frequencies near the edge of the radar detection bandwidth. For 802.11 devices it is suggested to select frequencies in each of the bonded 20 MHz channels and the channel center frequency.

| Table D.3: DFS Detection Thresholds | |
|---|------------------------------|
| Maximum Transmit Power | Value (See Notes 1,2, and 3) |
| EIRP \geq 200 mW | -64 dBm |
| EIRP < 200 mW and power spectral density < 10 dBm/MHz | -62 dBm |
| EIRP < 200 mW that do not meet the power spectral density requirement | -64 dBm |

Note 1: This is the level at the input of the receiver assuming a 0 dBi receive antenna.
 Note 2: Throughout these test procedures an additional 1 dB has been added to the amplitude of the test transmission waveforms to account for variations in measurement equipment. This will ensure that the test signal is at or above the detection threshold level to trigger a DFS response.
 Note 3: EIRP is based on the highest antenna gain. For MIMO devices refer to KDB Publication 662911 D01.

| Parameter | Value |
|-----------------------------------|---|
| Non-occupancy period | Minimum 30 minutes |
| Channel Availability Check Time | 60 seconds |
| Channel Move Time | 10 seconds (See Note 1) |
| Channel Closing Transmission Time | 200 ms + an aggregate of 60ms over remaining 10 second period (See Notes 1 and 2) |
| U-NII Detection Bandwidth | Minimum 100% of the UNII 99% transmission power bandwidth (See Note 3) |

Note 1: Channel Move Time and the Channel Closing Transmission Time should be performed with Radar Type 0. The measurement timing begins at the end of the Radar Type 0 burst.

Note 2: The Channel Closing Transmission Time is comprised of 200 milliseconds starting at the beginning of the Channel Move Time plus any additional intermittent control signals required to facilitate a Channel move (an aggregate of 60 milliseconds) during the remainder of the 10 second period. The aggregate duration of control signals will not count quiet periods in between transmissions.

Note 3: During the U-NII Detection Bandwidth detection test, radar type 0 should be used. For each frequency step, the minimum percentage of detection is 90 percent. Measurements are performed with no data traffic.

| Radar Type | Pulse Width (µsec) | PRI (µsec) | Number of Pulses | Minimum Percentage of Successful Detection | Minimum Number of Trials |
|-----------------------------|--------------------|------------------|---|--|--------------------------|
| 0 | 1 | 1428 | 18 | See Note 1 | See Note 1 |
| 1 | 1 | Test A Test B | Roundup $\left\{ \begin{matrix} \frac{1}{360} \\ \frac{19 \cdot 10^6}{PRI_{\mu sec}} \end{matrix} \right\}$ | 60% | 30 |
| 2 | 1-5 | 150-230 | 23-29 | 60% | 30 |
| 3 | 6-10 | 200-500 | 16-18 | 60% | 30 |
| 4 | 11-20 | 200-500 | 12-16 | 60% | 30 |
| Aggregate (Radar Types 1-4) | | | | 80% | 120 |

Note 1: Short Pulse Radar Type 0 should be used for the detection bandwidth test, channel move time, and channel closing time tests.

| Radar Type | Pulse Width (µsec) | Chirp Width (MHz) | PRI (µsec) | Number of Pulses per Burst | Number of Bursts | Minimum Percentage of Successful Detection | Minimum Number of Trials |
|------------|--------------------|-------------------|------------|----------------------------|------------------|--|--------------------------|
| 5 | 50-100 | 5-20 | 1000-2000 | 1-3 | 8-20 | 80% | 30 |

Long Pulse Radar Test Signal Wave form 12 second transmission

| Radar Type | Pulse Width (µsec) | PRI (µsec) | Pulses per Hop | Hopping Rate (kHz) | Hopping Sequence Length (msec) | Minimum Percentage of Successful Detection | Minimum Number of Trials |
|------------|--------------------|------------|----------------|--------------------|--------------------------------|--|--------------------------|
| 6 | 1 | 333 | 0 | 0.333 | 300 | 70% | 30 |

6.2 DFS Technical Requirements

| Requirement | DFS Operational mode | | |
|-----------------------------------|---------------------------------|---|---|
| | <input type="checkbox"/> Master | <input checked="" type="checkbox"/> Slave without Radar Detection | <input type="checkbox"/> Slave with Radar Detection |
| Channel Availability Check | √ | Not Required | Not Required |
| UNII Detection Bandwidth | √ | Not Required | √ |
| Statistical Performance Check | √ | Not Required | √ |
| Channel Move Time | √ | √ | √ |
| Channel Closing Transmission Time | √ | √ | √ |
| Non-Occupancy Period | √ | √ | √ |

6.3 DFS Threshold Level

| DFS Threshold Level | |
|--|-----------------------------|
| 5250MHz ~ 5350MHz | -61 dBm @ antenna connector |
| 5470MHz ~ 5725MHz | -61 dBm @ antenna connector |
| Note: The worst case level was selected to perform the test. | |

6.4 Test Setup Block

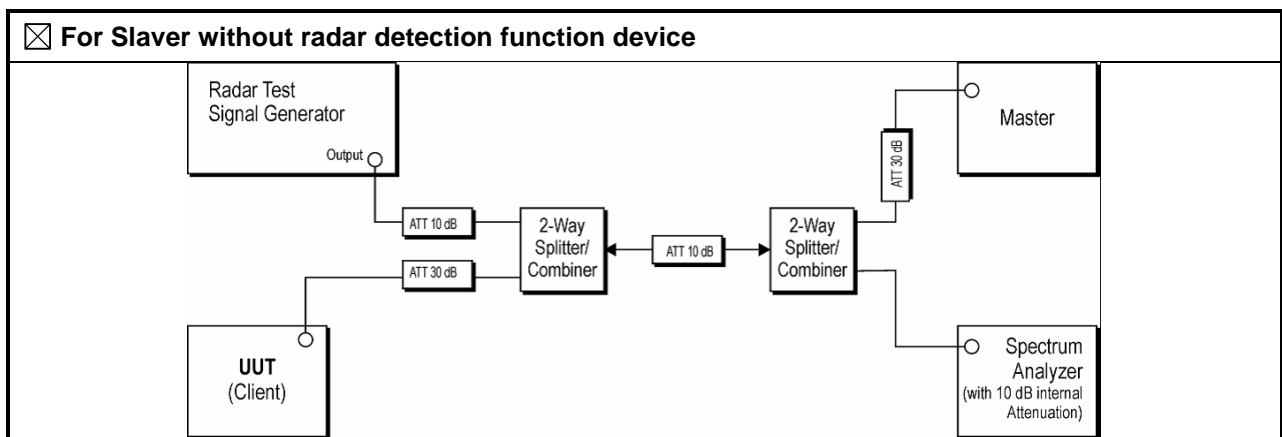
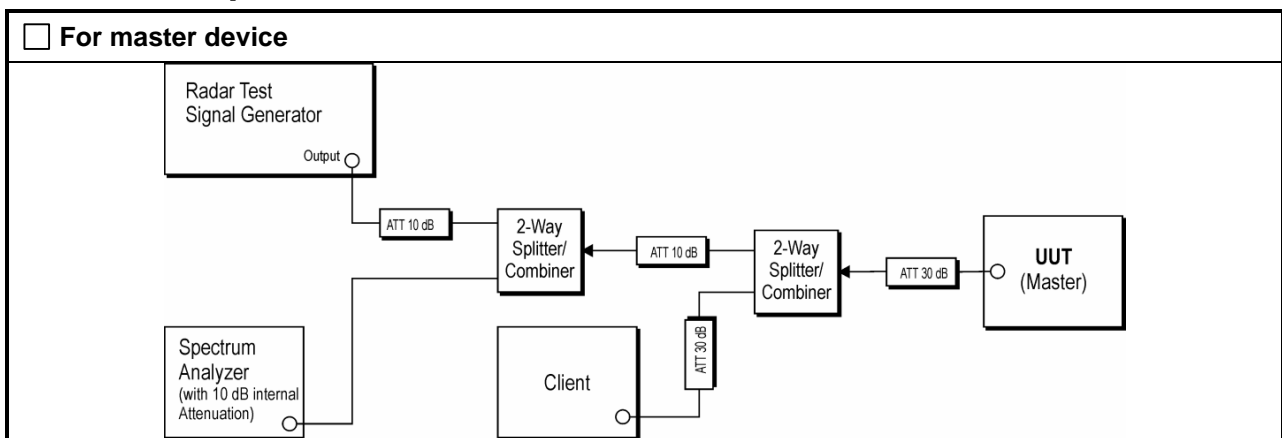

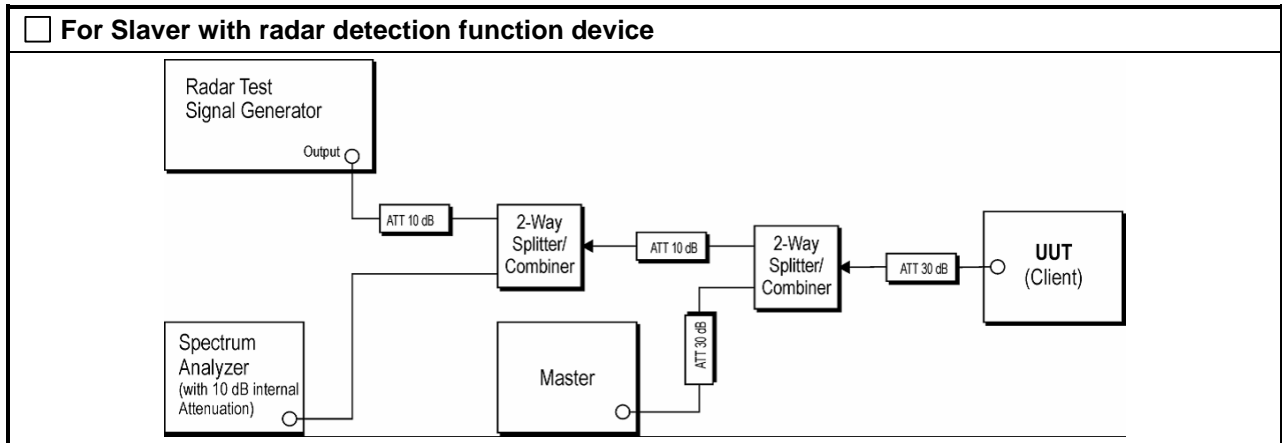

6.5 EUT Configuration for DFS Test

| Test Items | Channel Frequency |
|-----------------------------------|-------------------|
| Channel Move Time | 5290MHz, 5530MHz |
| Channel Closing Transmission Time | 5290MHz, 5530MHz |

7 Test Result

7.1 Verification of Radar Type and Level

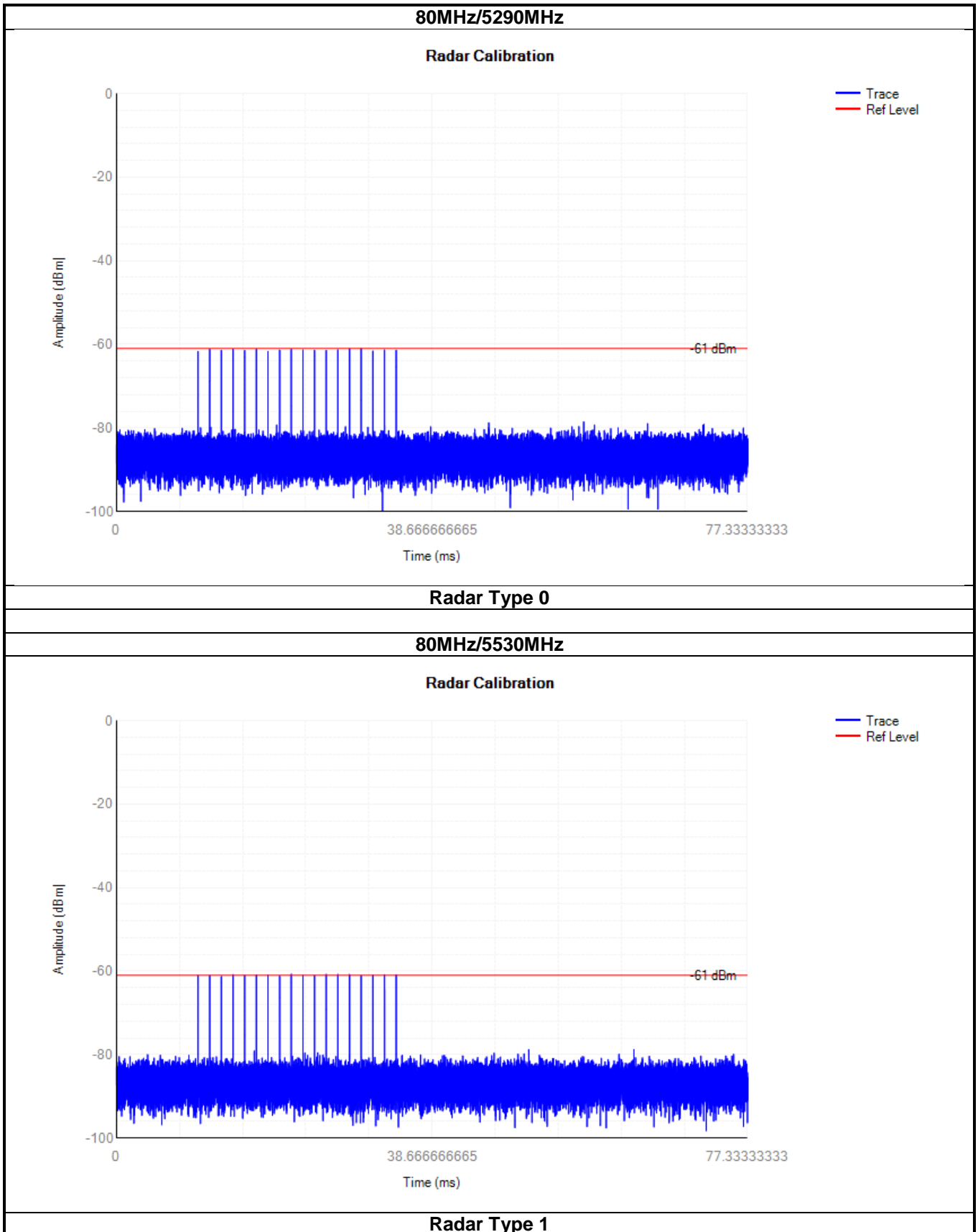

7.2 Channel Move Time and Channel Closing Transmission Time

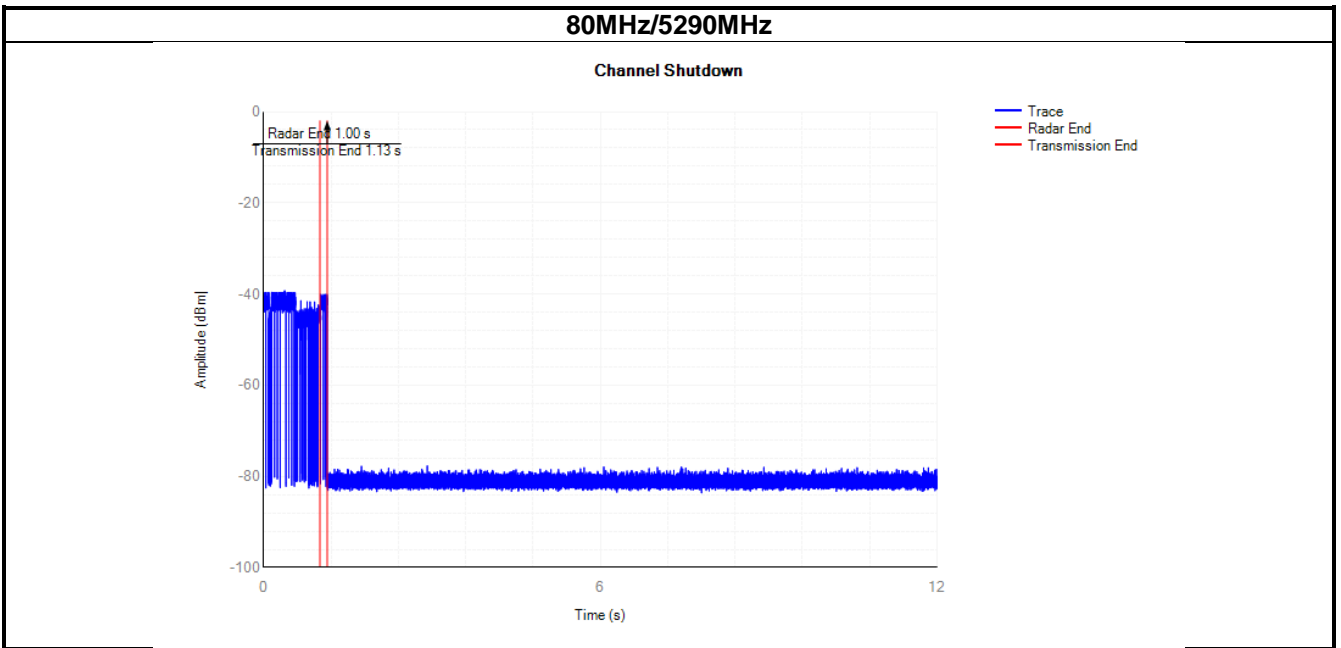

| Test Items | Value | Limit |
|-----------------------------------|--------|--------|
| Channel Closing Transmission Time | 127ms | 260 ms |
| Channel Move Time | 129 ms | 10 s |

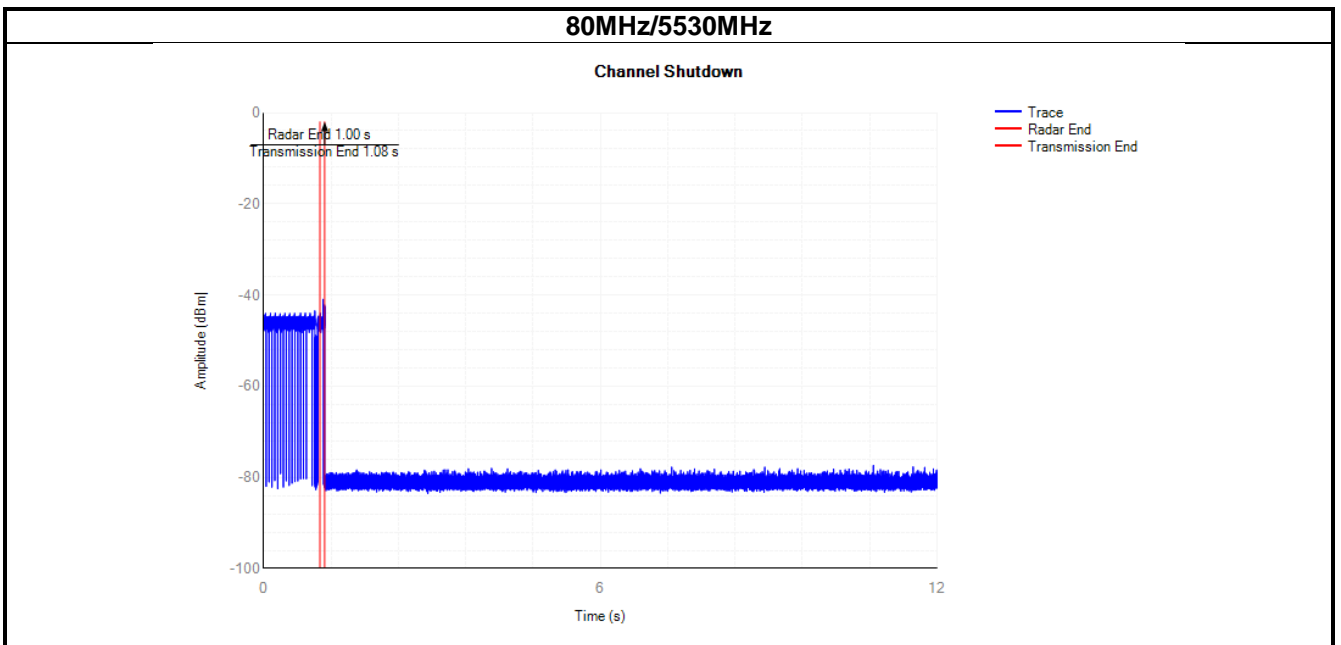

| Test Items | Value | Limit |
|-----------------------------------|-------|--------|
| Channel Closing Transmission Time | 84 ms | 260 ms |
| Channel Move Time | 85 ms | 10 s |

Test Result: Pass