

FCC RADIO TEST REPORT

FCC ID: 2ASMA-S611

Product : Wireless Digital Terminal

Trade Mark : **Neusoft**

Model Name : S611

Family Model : N/A

Report No. : S18122500501004

Prepared for

Neusoft Corporation
No.2 XinxiuStreet,Hunnan New
District,ShenyangCity,LiaoningProvince,China

Prepared by

Shenzhen NTEK Testing Technology Co., Ltd.
1/F, Building E, Fenda Science Park, Sanwei Community,
Xixiang Street Bao'an District, Shenzhen 518126 P.R. China
Tel.: +86-755-6115 6588
Fax.: +86-755-6115 6599
Website:<http://www.ntek.org.cn>

TEST RESULT CERTIFICATION

Applicant's name : Neusoft Corporation
Address : No.2 XinxiuStreet,Hunnan New District,ShenyangCity,LiaoningProvince,China

Manufacturer's Name : Neusoft Corporation
Address : No.2 XinxiuStreet,Hunnan New District,ShenyangCity,LiaoningProvince,China

Product description

Product name : Wireless Digital Terminal
Model and/or type reference : S611
Family Model : N/A

Standards : FCC Part15.407

Test procedure : ANSI C63.10-2013 and KDB 789033 D02 General U-NII Test Procedures New Rules v02r01
FCC KDB 905462 D02 UNII DFS Compliance Procedures New Rules v02

This device described above has been tested by NTEK, and the test results show that the equipment under test (EUT) is in compliance with the FCC requirements/ the Industry Canada requirements.. And it is applicable only to the tested sample identified in the report.

This report shall not be reproduced except in full, without the written approval of NTEK, this document may be altered or revised by NTEK, personnel only, and shall be noted in the revision of the document.

Date of Test

Date (s) of performance of tests : 26 Dec. 2018 ~ 05 Mar. 2019

Date of Issue : 23 Apr. 2019

Test Result : Pass

Testing Engineer : [Signature]
(Mary Hu)

Technical Manager : [Signature]
(Jason Chen)

Authorized Signatory : [Signature]
(Sam Chen)

Table of Contents

	Page
1 . SUMMARY OF TEST RESULTS	7
1.1 FACILITIES AND ACCREDITATIONS	8
1.2 MEASUREMENT UNCERTAINTY	8
2 . GENERAL INFORMATION	9
2.1 GENERAL DESCRIPTION OF EUT	9
2.2 DESCRIPTION OF TEST MODES	11
2.3 BLOCK DIGRAM SHOWING THE CONFIGURATION OF SYSTEM TESTED	12
2.4 DESCRIPTION OF SUPPORT UNITS(CONDUCTED MODE)	13
2.5 EQUIPMENTS LIST FOR ALL TEST ITEMS	14
3 . EMC EMISSION TEST	16
3.1 CONDUCTED EMISSION MEASUREMENT	16
3.1.1 APPLICABLE STANDARD	16
3.1.2 CONFORMANCE LIMIT	16
3.1.3 TEST CONFIGURATION	16
3.1.4 TEST PROCEDURE	16
3.2 RADIATED EMISSION MEASUREMENT	21
3.2.1 APPLICABLE STANDARD	21
3.2.2 CONFORMANCE LIMIT	21
3.2.3 MEASURING INSTRUMENTS	21
3.2.4 TEST CONFIGURATION	22
3.2.5 TEST PROCEDURE	23
3.2.6 TEST RESULTS (9KHZ – 30 MHZ)	24
3.2.7 TEST RESULTS (30MHZ – 1GHZ)	25
3.2.8 TEST RESULTS (1GHZ-26GHZ)	33
3.2.9 TEST RESULTS (26GHZ-40GHZ)	37
4 . POWER SPECTRAL DENSITY TEST	46
4.1 APPLIED PROCEDURES / LIMIT	46
4.2 TEST PROCEDURE	47
4.3 DEVIATION FROM STANDARD	47
4.4 TEST SETUP	47
4.5 EUT OPERATION CONDITIONS	47
4.6 TEST RESULTS	48
5 . 26DB & 99% EMISSION BANDWIDTH	64
5.1 APPLIED PROCEDURES / LIMIT	64
5.2 TEST PROCEDURE	64
5.3 EUT OPERATION CONDITIONS	65
5.4 TEST RESULTS	66

Table of Contents

	Page
6 . MINIMUM 6 DB BANDWIDTH	82
6.1 APPLIED PROCEDURES / LIMIT	82
6.2 TEST PROCEDURE	82
6.3 DEVIATION FROM STANDARD	82
6.4 TEST SETUP	82
6.5 EUT OPERATION CONDITIONS	82
6.6 TEST RESULTS	83
7 . MAXIMUM CONDUCTED OUTPUT POWER	87
7.1 PPLIED PROCEDURES / LIMIT	87
7.2 TEST PROCEDURE	87
7.3 DEVIATION FROM STANDARD	89
7.4 TEST SETUP	89
7.5 EUT OPERATION CONDITIONS	89
7.6 TEST RESULTS	90
8 . OUT OF BAND EMISSIONS	94
8.1 APPLICABLE STANDARD	94
8.2 TEST PROCEDURE	94
8.3 DEVIATION FROM STANDARD	94
8.4 TEST SETUP	94
8.5 EUT OPERATION CONDITIONS	95
8.6 TEST RESULTS	96
9.SPURIOUS RF CONDUCTED EMISSIONS	105
9.1CONFORMANCE LIMIT	105
9.2MEASURING INSTRUMENTS	105
9.3TEST SETUP	105
9.4TEST PROCEDURE	105
9.5TEST RESULTS	105
10. FREQUENCY STABILITY MEASUREMENT	119
10.1 LIMIT	119
10.2 TEST PROCEDURES	119
10.3 TEST SETUP LAYOUT	119
10.4 EUT OPERATION DURING TEST	119
10.5 TEST RESULTS	120
11. DYNAMIC FREQUENCY SELECTION(DFS)	132
11.1 APPLICABILITY OF DFS REQUIREMENTS	132
11.2 INTERFERENCE THRESHOLD VALUES, MASTER OR CLIENT INCORPORATING IN-SERVICE MONITORING	132

Table of Contents

	Page
11.3 DFS RESPONSE REQUIREMENT VALUES	133
11.4 SHORT PULSE RADAR TEST WAVEFORMS	133
11.5 CALIBRATION SETUP AND DFS TEST RESULTS	134
11.6 CONDUCTED CALIBRATION SETUP	134
11.7 RADAR WAVEFORM CALIBRATION RESULT	135
11.8 IN-SERVICE MONITORING: CHANNEL MOVE TIME, CHANNEL CLOSING TRANSMISSION TIME AND NON-OCCUPANCY PERIOD	137
11.9 RESULT OF CHANNEL MOVE TIME, CHANNEL CLOSING TRANSMISSION TIME AND NON-OCCUPANCY PERIOD FOR CLIENT BEACON TEST	138
12. ANTENNA REQUIREMENT	140
12.1 STANDARD REQUIREMENT	140
12.2 EUT ANTENNA	140

Revision History

Report No.	Version	Description	Issued Date
S18122500501004	Rev.01	Initial issue of report	23 Apr. 2019

1. SUMMARY OF TEST RESULTS

Test procedures according to the technical standards:

FCC Part15 (15.407) , Subpart E			
Standard Section	Test Item	Judgment	Remark
15.207	AC Power Line Conducted Emissions	PASS	
15.209(a), 15.407 (b)(1) 15.407 (b)(2) 15.407 (b)(3) 15.407 (b)(4) 15.407 (b)(6)	Spurious Radiated Emissions	PASS	
15.407 (a)	26 dB and 99% Emission Bandwidth	PASS	
15.407(e)	Minimum 6 dB bandwidth	PASS	
15.407 (a)	Maximum Conducted Output Power	PASS	
15.407 (b)(1) 15.407 (b)(2) 15.407 (b)(3) 15.407 (b)(4)	Band Edge	PASS	
15.407 (a)	Power Spectral Density	PASS	
15.407(b)	Spurious Emissions at Antenna Terminals	PASS	
15.407(h)	Dynamic Frequency Selection(DFS)	PASS	Subcontract test(note 2)
15.203	Antenna Requirement	PASS	

NOTE:

(1) "N/A" denotes test is not applicable in this Test Report

(2) Subcontracted laboratory information:

Firm Name:

Shenzhen Huatongwei International Inspection Co., Ltd.

Designation Number:CN1181

Test Firm Registration Number: 762235

A2LA Certificate Registration Number : 3902.01

1.1 FACILITIES AND ACCREDITATIONS

FACILITIES

All measurement facilities used to collect the measurement data are located at 1/F, Building E, Fenda Science Park, Sanwei Community, Xixiang Street, Bao'an District, Shenzhen 518126 P.R. China.

The sites are constructed in conformance with the requirements of ANSI C63.7, ANSI C63.10 and CISPR Publication 22.

LABORATORY ACCREDITATIONS AND LISTINGS

Site Description

CNAS-Lab. : The Laboratory has been assessed and proved to be in compliance with CNAS-CL01:2006 (identical to ISO/IEC 17025:2005)
The Certificate Registration Number is L5516.

IC-Registration The Certificate Registration Number is 9270A-1.

FCC- Accredited Test Firm Registration Number: 463705.
Designation Number: CN1184

A2LA-Lab. The Certificate Registration Number is 4298.01
This laboratory is accredited in accordance with the recognized International Standard ISO/IEC 17025:2005 General requirements for the competence of testing and calibration laboratories.
This accreditation demonstrates technical competence for a defined scope and the operation of a laboratory quality management system (refer to joint ISO-ILAC-IAF Communiqué dated 8 January 2009).

Name of Firm : Shenzhen NTEK Testing Technology Co., Ltd.

Site Location : 1/F, Building E, Fenda Science Park, Sanwei Community, Xixiang Street, Bao'an District, Shenzhen 518126 P.R. China.

1.2 MEASUREMENT UNCERTAINTY

The reported uncertainty of measurement $y \pm U$, where expanded uncertainty U is based on a standard uncertainty multiplied by a coverage factor of $k=2$, providing a level of confidence of approximately 95 %.

No.	Item	Uncertainty
1	Conducted Emission Test	$\pm 2.80\text{dB}$
2	RF power, conducted	$\pm 0.16\text{dB}$
3	Spurious emissions, conducted	$\pm 0.21\text{dB}$
4	All emissions, radiated(30MHz~1GHz)	$\pm 2.64\text{dB}$
5	All emissions, radiated(1GHz~6GHz)	$\pm 2.40\text{dB}$
6	All emissions, radiated(> 6GHz)	$\pm 2.52\text{dB}$
7	Temperature	$\pm 0.5^\circ\text{C}$
8	Humidity	$\pm 2\%$

2. GENERAL INFORMATION

2.1 GENERAL DESCRIPTION OF EUT

Equipment	Wireless Digital Terminal																
Trade Mark	Neusoft																
Model Name	S611																
FCC ID	2ASMA-S611																
Product Description	<table border="1"> <tr> <td>Mode Supported</td> <td> <input checked="" type="checkbox"/> 802.11a <input checked="" type="checkbox"/> 802.11n(HT20) <input checked="" type="checkbox"/> 802.11n(HT40) <input checked="" type="checkbox"/> 802.11ac(HT20) <input checked="" type="checkbox"/> 802.11ac(HT40) <input checked="" type="checkbox"/> 802.11ac(HT80) </td> </tr> <tr> <td>Data Rate</td> <td> 802.11a: 6,9,12,18,24,36,48,54Mbps; 802.11n(HT20/HT40):MCS0-MCS15; 802.11ac(VHT20): NSS1, MCS0-MCS8 802.11ac(VHT40/VHT80):NSS1, MCS0-MCS9 </td> </tr> <tr> <td>Modulation</td> <td>OFDM with BPSK/QPSK/16QAM/64QAM</td> </tr> <tr> <td>Operating Frequency Range</td> <td> <input checked="" type="checkbox"/> U-NII-1: 5150 MHz ~5250MHz <input checked="" type="checkbox"/> U-NII-2A: 5250MHz~5350MHz <input checked="" type="checkbox"/> U-NII-2C: 5470MHz~5725MHz <input checked="" type="checkbox"/> U-NII-3: 5725 MHz ~5825 MHz </td> </tr> <tr> <td>Function:</td> <td> <input type="checkbox"/> Outdoor AP <input type="checkbox"/> Indoor AP <input type="checkbox"/> Fixed P2P <input checked="" type="checkbox"/> Client </td> </tr> <tr> <td>DFS type:</td> <td> <input type="checkbox"/> master devices <input type="checkbox"/> Slave devices with radar detection <input checked="" type="checkbox"/> Slave devices without radar detection </td> </tr> <tr> <td>Antenna Type</td> <td>FPCB Antenna</td> </tr> <tr> <td>Antenna Gain</td> <td>0.9 dBi</td> </tr> </table>	Mode Supported	<input checked="" type="checkbox"/> 802.11a <input checked="" type="checkbox"/> 802.11n(HT20) <input checked="" type="checkbox"/> 802.11n(HT40) <input checked="" type="checkbox"/> 802.11ac(HT20) <input checked="" type="checkbox"/> 802.11ac(HT40) <input checked="" type="checkbox"/> 802.11ac(HT80)	Data Rate	802.11a: 6,9,12,18,24,36,48,54Mbps; 802.11n(HT20/HT40):MCS0-MCS15; 802.11ac(VHT20): NSS1, MCS0-MCS8 802.11ac(VHT40/VHT80):NSS1, MCS0-MCS9	Modulation	OFDM with BPSK/QPSK/16QAM/64QAM	Operating Frequency Range	<input checked="" type="checkbox"/> U-NII-1: 5150 MHz ~5250MHz <input checked="" type="checkbox"/> U-NII-2A: 5250MHz~5350MHz <input checked="" type="checkbox"/> U-NII-2C: 5470MHz~5725MHz <input checked="" type="checkbox"/> U-NII-3: 5725 MHz ~5825 MHz	Function:	<input type="checkbox"/> Outdoor AP <input type="checkbox"/> Indoor AP <input type="checkbox"/> Fixed P2P <input checked="" type="checkbox"/> Client	DFS type:	<input type="checkbox"/> master devices <input type="checkbox"/> Slave devices with radar detection <input checked="" type="checkbox"/> Slave devices without radar detection	Antenna Type	FPCB Antenna	Antenna Gain	0.9 dBi
	Mode Supported	<input checked="" type="checkbox"/> 802.11a <input checked="" type="checkbox"/> 802.11n(HT20) <input checked="" type="checkbox"/> 802.11n(HT40) <input checked="" type="checkbox"/> 802.11ac(HT20) <input checked="" type="checkbox"/> 802.11ac(HT40) <input checked="" type="checkbox"/> 802.11ac(HT80)															
	Data Rate	802.11a: 6,9,12,18,24,36,48,54Mbps; 802.11n(HT20/HT40):MCS0-MCS15; 802.11ac(VHT20): NSS1, MCS0-MCS8 802.11ac(VHT40/VHT80):NSS1, MCS0-MCS9															
	Modulation	OFDM with BPSK/QPSK/16QAM/64QAM															
	Operating Frequency Range	<input checked="" type="checkbox"/> U-NII-1: 5150 MHz ~5250MHz <input checked="" type="checkbox"/> U-NII-2A: 5250MHz~5350MHz <input checked="" type="checkbox"/> U-NII-2C: 5470MHz~5725MHz <input checked="" type="checkbox"/> U-NII-3: 5725 MHz ~5825 MHz															
	Function:	<input type="checkbox"/> Outdoor AP <input type="checkbox"/> Indoor AP <input type="checkbox"/> Fixed P2P <input checked="" type="checkbox"/> Client															
	DFS type:	<input type="checkbox"/> master devices <input type="checkbox"/> Slave devices with radar detection <input checked="" type="checkbox"/> Slave devices without radar detection															
	Antenna Type	FPCB Antenna															
	Antenna Gain	0.9 dBi															
	Based on the application, features, or specification exhibited in User's Manual, More details of EUT technical specification, please refer to the User's Manual.																
Ratings	DC 3.85V/4600mAh from Battery or DC 5V.																
Adapter	Model: ICP12-050-2000B Input: 100-240V~50/60Hz 0.5A Output: 5V---2000mA																
Connecting I/O Port(s)	Please refer to the User's Manual																
HW Version	PD510_MB_V1.3																
SW Version	Ubione-user_#17																

Note:

1. For a more detailed features description, please refer to the manufacturer's specifications or the User's Manual.
2. Frequency and Channel list:

Band	20MHz		40MHz		80MHz	
	Channel	Frequency	Channel	Frequency	Channel	Frequency
U-NII-1	36	5180 MHz	38	5190 MHz	42	5210 MHz
	40	5200 MHz	46	5230 MHz	-	-
	44	5220 MHz				
	48	5240 MHz				
U-NII-2A	52	5260 MHz	54	5270 MHz	58	5290 MHz
	56	5280 MHz	62	5310 MHz		
	60	5300 MHz				
	64	5320 MHz				
U-NII-2C	100	5500 MHz	102	5510 MHz	106	5530 MHz
	104	5520 MHz	110	5550 MHz	122	5610 MHz
	108	5540 MHz	118	5590 MHz		
	112	5560 MHz	126	5630 MHz		
	116	5580 MHz	134	5670 MHz		
	120	5600 MHz				
	124	5620 MHz				
	128	5640 MHz				
	132	5660 MHz				
140	5700 MHz					
U-NII-3	149	5745 MHz	151	5755 MHz	155	5775 MHz
	153	5765 MHz	159	5795 MHz		
	157	5785 MHz				
	161	5805 MHz				
	165	5825 MHz				

Tx Antenna

Antenna	Antenna Type	Antenna Gain(dBi)
		5.0G
A(main)	FPCB	0.9

2.2 DESCRIPTION OF TEST MODES

To investigate the maximum EMI emission characteristics generates from EUT, the test system was pre-scanning tested base on the consideration of following EUT operation mode or test configuration mode which possible have effect on EMI emission level. Each of these EUT operation mode(s) or test configuration mode(s) mentioned above was evaluated respectively.

Test Items	Mode	Data Rate	Channel	Ant
AC Power Line Conducted Emissions	Normal Link	-	-	-
Maximum Conducted Output Power	11a/n(20)/ac(20)	6 Mbps/ MCS0/ VHT1MCS0	36/40/48/52/56/64/100 /120/140/149/157/165	1
	11n(40)/ac(40)	MCS0/ VHT1MCS0	38/46/54/62/102/110 /118/134/151/159	1
	11ac(80)	MCS0/ VHT1MCS0	42/58/106/122/155	1
Power Spectral Density	11a/n(20)/ac(20)	6 Mbps/ MCS0/ VHT1MCS0	36/40/48/52/56/64/100 /120/140/149/157/165	1
	11n(40)/ac(40)	VHT1MCS0	38/46/54/62/102/110 /118/134/151/159	1
	11ac(80)	MCS0	42/58/106/122/155	1
26 dB and 99% Emission Bandwidth	11a/n(20)/ac(20)	6 Mbps/ MCS0/ VHT1MCS0	36/40/48/52/56/64/100 /120/140/149/157/165	1
	11n(40)/ac(40)	MCS0/ VHT1MCS0	38/46/54/62/102/110 /118/134/151/159	1
	11ac(80)	MCS0	42/58/106/122/155	1
Minimum 6 dB bandwidth	11a/n(20)/ac(20)	6 Mbps/ MCS0/ VHT1MCS0	36/40/48/52/56/64/100 /120/140/149/157/165	1
	11n(40)/ac(40)	VHT1MCS0	38/46/54/62/102/110 /118/134/151/159	1
	11ac(80)	MCS0	42/58/106/122/155	1
Radiated Emissions Below 1GHz	Normal Link	-	-	1
Radiated Emissions Above 1GHz	11a/n(20)/ac(20)	6 Mbps/ MCS0/ VHT1MCS0	36/40/48/52/56/64/100 /120/140/149/157/165	1
	11n(40)/ac(40)	VHT1MCS0	38/46/54/62/102/110 /118/134/151/159	1
	11ac(80)	MCS0	42/58/106/122/155	1
Band Edge Emissions	11a/n(20)/ac(20)	6 Mbps/ MCS0/ VHT1MCS0	36/40/48/52/56/64/100 /120/140/149/157/165	1
	11n(40)/ac(40)	MCS0/ VHT1MCS0	38/46/54/62/102/110 /118/134/151/159	1
	11ac(80)	MCS0	42/58/106/122/155	1
Dynamic Frequency Selection(DFS)	ac(80)	VHT1MCS0	58/106	1

Note:

- (1) The measurements are performed at the highest, middle, lowest available channels.
- (2) The measurements are performed at all Bit Rate of Transmitter, the worst data was reported

2.3 BLOCK DIGRAM SHOWING THE CONFIGURATION OF SYSTEM TESTED

For AC Conducted Emission Mode



For Radiated Test Cases



For Conducted Test Cases

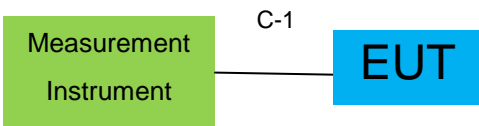

Note: 1. The temporary antenna connector is soldered on the PCB board in order to perform conducted tests and this temporary antenna connector is listed in the equipment list.

1. EUT built-in battery-powered, the battery is fully-charged.

2.4 DESCRIPTION OF SUPPORT UNITS(CONDUCTED MODE)

The EUT has been tested as an independent unit together with other necessary accessories or support units. The following support units or accessories were used to form a representative test configuration during the tests.

Item	Equipment	Brand	Model/Type No.	Series No.	Note

Item	Cable Type	Shielded Type	Ferrite Core	Length	Note
C-1	RF Cable	YES	NO	0.1m	

Note:

- (1) The support equipment was authorized by Declaration of Confirmation.
- (2) For detachable type I/O cable should be specified the length in cm in 『Length』 column.

2.5 EQUIPMENTS LIST FOR ALL TEST ITEMS

Radiation& Conducted Test equipment

Item	Kind of Equipment	Manufacturer	Type No.	Serial No.	Last calibration	Calibrated until	Calibration period
1	Spectrum Analyzer	Agilent	E4407B	MY45108040	2018.05.19	2019.05.18	1 year
2	Spectrum Analyzer	Agilent	N9020A	MY49100060	2018.10.08	2019.10.07	1 year
3	Spectrum Analyzer	R&S	FSV40	101417	2018.10.08	2019.10.07	1 year
4	Test Receiver	R&S	ESPI7	101318	2018.05.19	2019.05.18	1 year
5	Bilog Antenna	TESEQ	CBL6111D	31216	2018.04.08	2019.04.07	1 year
6	50Ω Coaxial Switch	Anritsu	MP59B	6200983705	2018.05.19	2020.05.18	2 year
7	Horn Antenna	EM	EM-AH-10180	2011071402	2018.04.08	2019.04.07	1 year
8	Broadband Horn Antenna	SCHWARZBECK	BBHA 9170	803	2018.11.03	2019.11.02	1 year
9	Amplifier	EMC	EMC051835SE	980246	2018.08.05	2019.08.04	1 year
10	Active Loop Antenna	SCHWARZBECK	FMZB 1519B	055	2018.11.03	2019.11.02	1 year
11	Power Meter	DARE	RPR3006W	15100041SN084	2018.08.05	2019.08.04	1 year
12	Test Cable (9KHz-30MHz)	N/A	R-01	N/A	2017.04.21	2020.04.20	3 year
13	Test Cable (30MHz-1GHz)	N/A	R-02	N/A	2017.04.21	2020.04.20	3 year
14	High Test Cable(1G-40G Hz)	N/A	R-03	N/A	2017.04.21	2020.04.20	3 year
15	High Test Cable(1G-40G Hz)	N/A	R-04	N/A	2017.04.21	2020.04.20	3 year
16	Filter	TRILTHIC	2400MHz	29	2017.04.19	2020.04.18	3 year
17	temporary antenna connector (Note)	NTS	R001	N/A	N/A	N/A	N/A

Item	Kind of Equipment	Manufacturer	Type No.	FCC ID
18	Wireless AP	LINKSYS LLC	WRT32X	Q87-WRT3200ACM

Note:

We will use the temporary antenna connector (soldered on the PCB board) When conducted test
And this temporary antenna connector is listed within the instrument list

AC Conduction Test equipment

Item	Kind of Equipment	Manufacturer	Type No.	Serial No.	Last calibration	Calibrated until	Calibration period
1	Test Receiver	R&S	ESCI	101160	2018.05.19	2019.05.18	1 year
2	LISN	R&S	ENV216	101313	2018.04.18	2019.04.19	1 year
3	LISN	SCHWARZBECK	NNLK 8129	8129245	2018.05.19	2019.05.18	1 year
4	50Ω Coaxial Switch	ANRITSU CORP	MP59B	6200983704	2018.05.19	2020.05.18	2 year
5	Test Cable (9KHz-30MHz)	N/A	C01	N/A	2017.04.21	2020.04.20	3 year
6	Test Cable (9KHz-30MHz)	N/A	C02	N/A	2017.04.21	2020.04.20	3 year
7	Test Cable (9KHz-30MHz)	N/A	C03	N/A	2017.04.21	2020.04.20	3 year

Note: Each piece of equipment is scheduled for calibration once a year except the Test Cable& Aux Equipment which is scheduled for calibration every 3 years.

3. EMC EMISSION TEST

3.1 CONDUCTED EMISSION MEASUREMENT

3.1.1 APPLICABLE STANDARD

According to FCC Part 15.207(a) and KDB 174176 D01 Line Conducted FAQ v01r01

3.1.2 CONFORMANCE LIMIT

Frequency(MHz)	Conducted Emission Limit	
	Quasi-peak	Average
0.15-0.5	66-56*	56-46*
0.5-5.0	56	46
5.0-30.0	60	50

Note: 1. *Decreases with the logarithm of the frequency
 2. The lower limit shall apply at the transition frequencies
 3. The limit decreases in line with the logarithm of the frequency in the range of 0.15 to 0.50MHz.

3.1.3 TEST CONFIGURATION

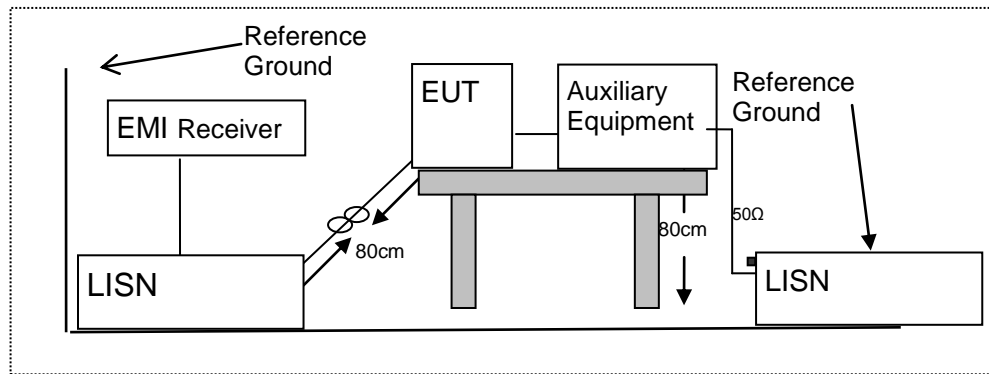

3.1.4 TEST PROCEDURE

According to the requirements in Section 13.1.4.1 of ANSI C63.10-2013 Conducted emissions the EUT measured in the frequency range between 0.15 MHz and 30 MHz using CISPR Quasi-Peak and average detector mode.

1. The EUT was placed 0.4 meter from the conducting wall of the shielding room.
2. The EUT was placed on a table which is 0.8m above ground plane.
3. Connect EUT to the power mains through a line impedance stabilization network (LISN). All other support equipments powered from additional LISN(s). The LISN provide 50 Ohm/ 50uH of coupling impedance for the measuring instrument.
4. Interconnecting cables that hang closer than 40 cm to the ground plane shall be folded back and forth in the center forming a bundle 30 to 40cm long.
5. I/O cables that are not connected to a peripheral shall be bundled in the center. The end of the cable may be terminated, if required, using the correct terminating impedance. The overall length shall not exceed 1 m.
6. LISN at least 80 cm from nearest part of EUT chassis.
7. The frequency range from 150KHz to 30MHz was searched.
8. Set the test-receiver system to Peak Detect Function and specified bandwidth(IF bandwidth=9KHz) with Maximum Hold Mode
9. For the actual test configuration, please refer to the related Item –EUT Test Photos.

EUT :	Wireless Digital Terminal	Model Name. :	S611
Temperature :	26 °C	Relative Humidity :	56%
Pressure :	1010hPa	Phase :	L
Test Voltage :	DC 5V from Adapter AC 120V/60Hz	Test Mode :	Mode 1

Frequency (MHz)	Reading Level (dBμV)	Correct Factor (dB)	Measure-ment (dBμV)	Limits (dBμV)	Margin (dB)	Remark
0.1660	46.03	9.76	55.79	65.15	-9.36	QP
0.1660	31.58	9.76	41.34	55.15	-13.81	AVG
0.1985	47.14	9.76	56.90	63.67	-6.77	QP
0.2020	25.59	9.76	35.35	53.52	-18.17	AVG
0.2977	39.27	9.74	49.01	60.30	-11.29	QP
0.2977	23.34	9.74	33.08	50.30	-17.22	AVG
0.3497	39.79	9.73	49.52	58.97	-9.45	QP
0.3501	23.16	9.73	32.89	48.96	-16.07	AVG
0.9657	19.42	9.74	29.16	46.00	-16.84	AVG
0.9778	35.92	9.74	45.66	56.00	-10.34	QP
2.3179	21.72	9.79	31.51	46.00	-14.49	AVG
2.3699	34.16	9.79	43.95	56.00	-12.05	QP

Remark:

1. All readings are Quasi-Peak and Average values.
2. Factor = Insertion Loss + Cable Loss.

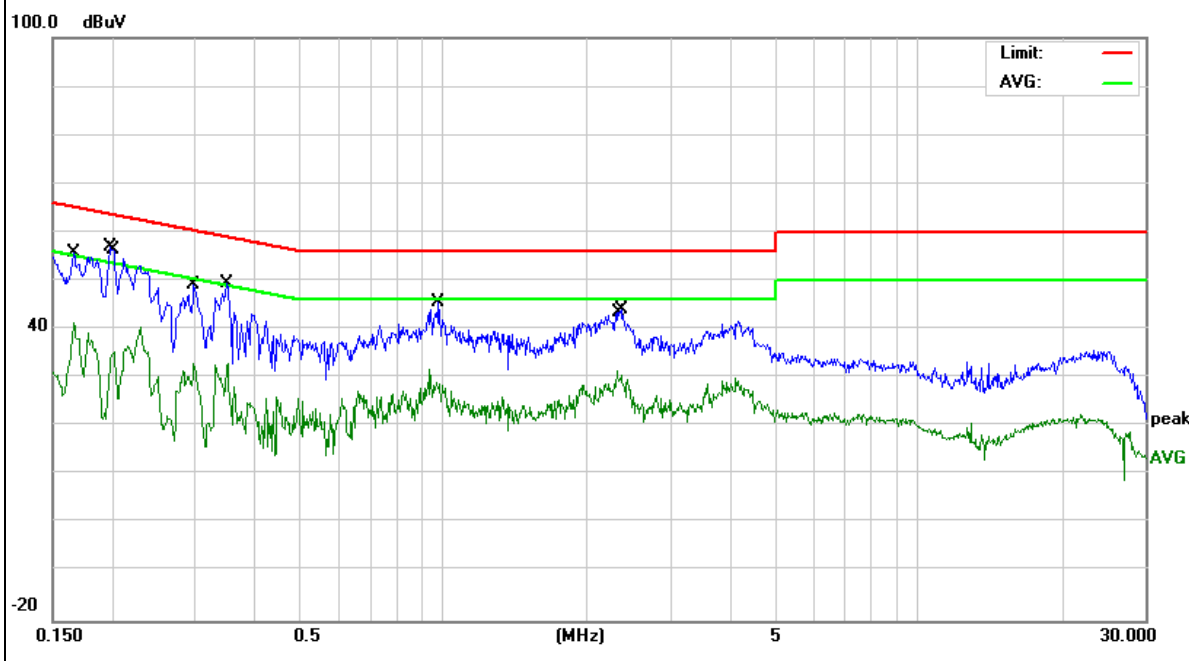

EUT :	Wireless Digital Terminal	Model Name. :	S611
Temperature :	26 °C	Relative Humidity :	56%
Pressure :	1010hPa	Phase :	N
Test Voltage :	DC 5V from Adapter AC 120V/60Hz	Test Mode :	Mode 1

Frequency (MHz)	Reading Level (dBμV)	Correct Factor (dB)	Measure-ment (dBμV)	Limits (dBμV)	Margin (dB)	Remark
0.1580	45.72	9.74	55.46	65.56	-10.10	QP
0.1580	25.08	9.74	34.82	55.56	-20.74	AVG
0.2340	25.62	9.74	35.36	52.30	-16.94	AVG
0.2379	41.01	9.74	50.75	62.17	-11.42	QP
0.3260	40.18	9.74	49.92	59.55	-9.63	QP
0.3379	15.96	9.74	25.70	49.25	-23.55	AVG
0.5100	19.28	9.75	29.03	46.00	-16.97	AVG
0.5140	35.58	9.75	45.33	56.00	-10.67	QP
2.3020	34.11	9.81	43.92	56.00	-12.08	QP
2.3260	13.59	9.81	23.40	46.00	-22.60	AVG
4.8258	11.37	9.94	21.31	46.00	-24.69	AVG
4.8738	30.49	9.94	40.43	56.00	-15.57	QP

Remark:

1. All readings are Quasi-Peak and Average values.
2. Factor = Insertion Loss + Cable Loss.

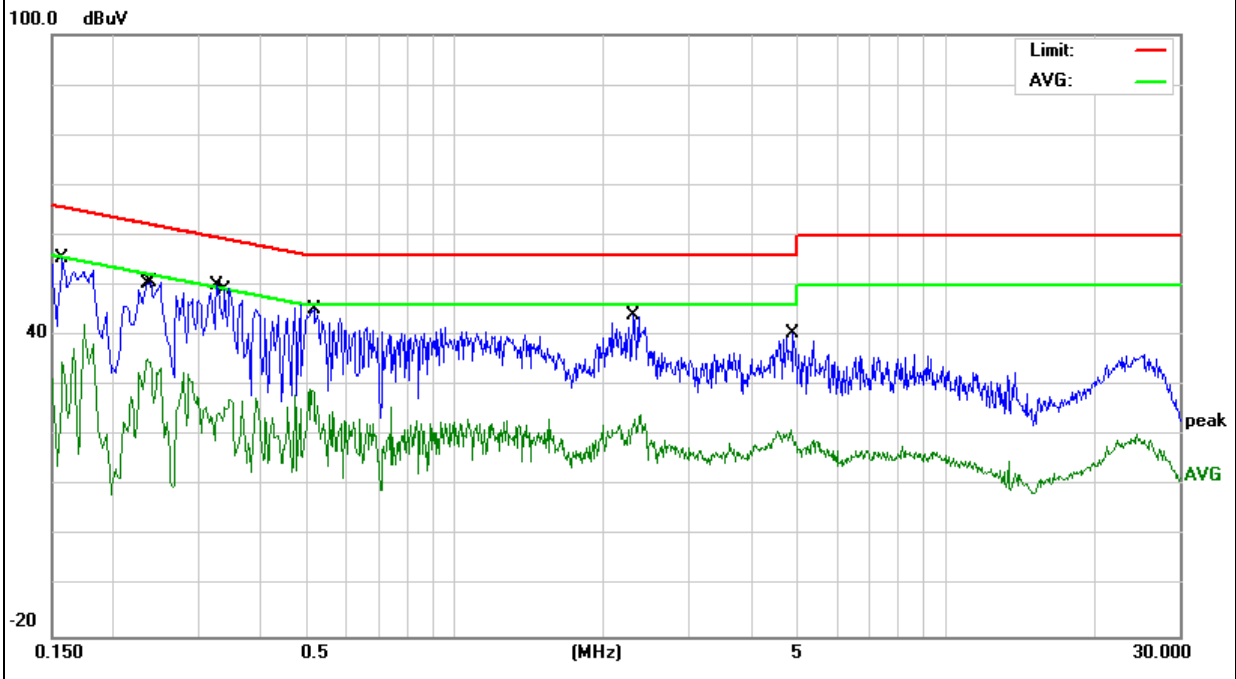

EUT :	Wireless Digital Terminal	Model Name. :	S611
Temperature :	26 °C	Relative Humidity :	56%
Pressure :	1010hPa	Phase :	L
Test Voltage :	DC 5V from Adapter AC 240V/60Hz	Test Mode :	Mode 1

Frequency (MHz)	Reading Level (dBμV)	Correct Factor (dB)	Measure-ment (dBμV)	Limits (dBμV)	Margin (dB)	Remark
0.1580	46.22	9.74	55.96	65.56	-9.60	QP
0.1580	25.58	9.74	35.32	55.56	-20.24	AVG
0.2116	42.52	9.73	52.25	63.14	-10.89	QP
0.2179	24.59	9.73	34.32	52.89	-18.57	AVG
0.2700	42.64	9.74	52.38	61.12	-8.74	QP
0.2779	23.37	9.74	33.11	50.88	-17.77	AVG
0.5140	16.12	9.75	25.87	46.00	-20.13	AVG
0.5220	33.82	9.75	43.57	56.00	-12.43	QP
1.8020	16.82	9.79	26.61	46.00	-19.39	AVG
1.8300	34.67	9.79	44.46	56.00	-11.54	QP
5.3619	32.92	9.94	42.86	60.00	-17.14	QP
5.4778	14.51	9.94	24.45	50.00	-25.55	AVG

Remark:

1. All readings are Quasi-Peak and Average values.
2. Factor = Insertion Loss + Cable Loss.

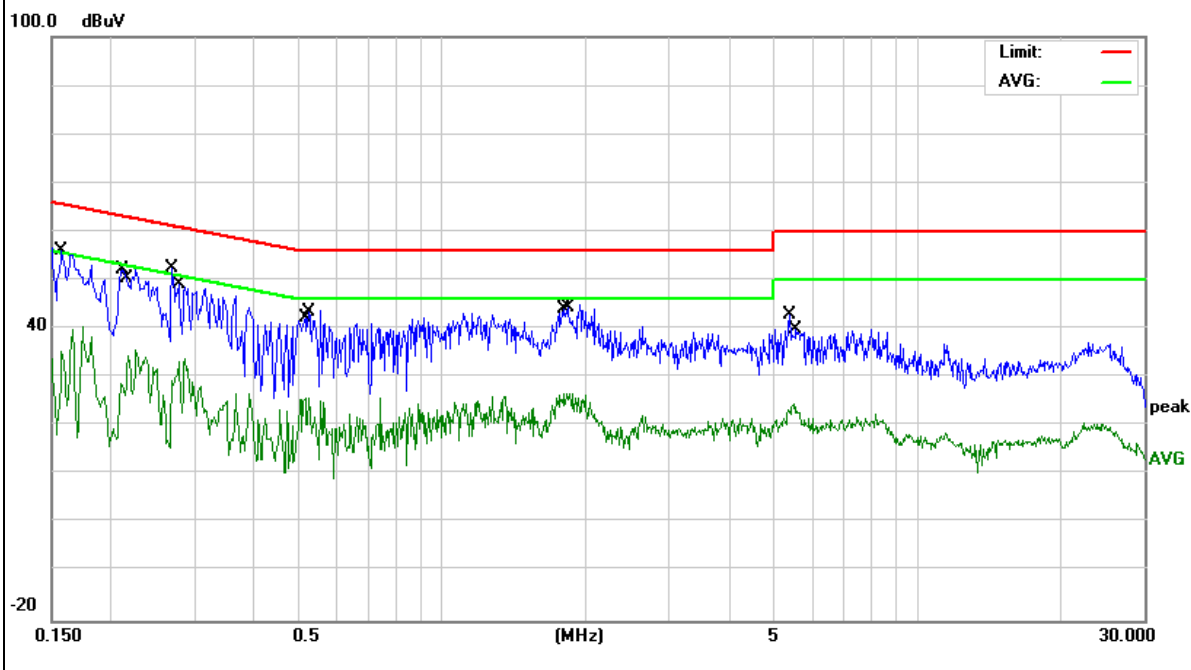

EUT :	Wireless Digital Terminal	Model Name. :	S611
Temperature :	26 °C	Relative Humidity :	56%
Pressure :	1010hPa	Phase :	N
Test Voltage :	DC 5V from Adapter AC 240V/60Hz	Test Mode :	Mode 1

Frequency (MHz)	Reading Level (dBμV)	Correct Factor (dB)	Measure-ment (dBμV)	Limits (dBμV)	Margin (dB)	Remark
0.1819	46.57	9.73	56.30	64.39	-8.09	QP
0.1819	32.20	9.73	41.93	54.39	-12.46	AVG
0.2300	44.27	9.74	54.01	62.45	-8.44	QP
0.2300	29.52	9.74	39.26	52.45	-13.19	AVG
0.2857	41.87	9.74	51.61	60.65	-9.04	QP
0.2857	25.49	9.74	35.23	50.65	-15.42	AVG
0.7500	18.10	9.75	27.85	46.00	-18.15	AVG
0.7539	36.70	9.75	46.45	56.00	-9.55	QP
2.9060	17.14	9.86	27.00	46.00	-19.00	AVG
2.9820	36.59	9.87	46.46	56.00	-9.54	QP
3.4620	36.59	9.89	46.48	56.00	-9.52	QP
3.5899	16.42	9.90	26.32	46.00	-19.68	AVG

Remark:

1. All readings are Quasi-Peak and Average values.
2. Factor = Insertion Loss + Cable Loss.

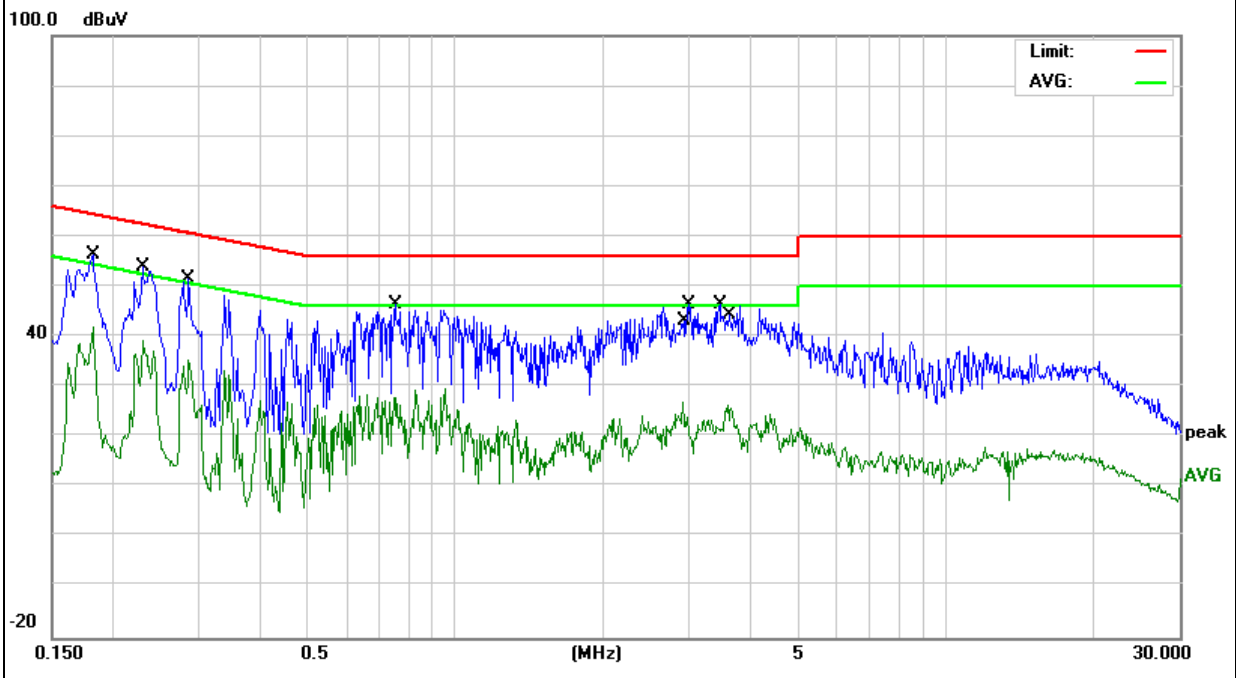

3.2 RADIATED EMISSION MEASUREMENT

3.2.1 APPLICABLE STANDARD

According to FCC Part 15.407(d) and 15.209

3.2.2 CONFORMANCE LIMIT

According to FCC Part 15.407(b)(7): radiated emissions which fall in the restricted bands, as defined in §15.205(a), must also comply with the radiated emission limits specified in §15.209(a) (see §15.205(c)).
According to FCC Part 15.205, Restricted bands

MHz	MHz	MHz	GHz
0.090-0.110	16.42-16.423	399.9-410	4.5-5.15
0.495-0.505	16.69475-16.69525	608-614	5.35-5.46
2.1735-2.1905	16.80425-16.80475	960-1240	7.25-7.75
4.125-4.128	25.5-25.67	1300-1427	8.025-8.5
4.17725-4.17775	37.5-38.25	1435-1626.5	9.0-9.2
4.20725-4.20775	73-74.6	1645.5-1646.5	9.3-9.5
6.215-6.218	74.8-75.2	1660-1710	10.6-12.7
6.26775-6.26825	123-138	2200-2300	14.47-14.5
8.291-8.294	149.9-150.05	2310-2390	15.35-16.2
8.362-8.366	156.52475-156.52525	2483.5-2500	17.7-21.4
8.37625-8.38675	156.7-156.9	2690-2900	22.01-23.12
8.41425-8.41475	162.0125-167.17	3260-3267	23.6-24.0
12.29-12.293	167.72-173.2	3332-3339	31.2-31.8
12.51975-12.52025	240-285	3345.8-3358	36.43-36.5
12.57675-12.57725	322-335.4	3600-4400	(2)
13.36-13.41			

20dBc in any 100 kHz bandwidth outside the operating frequency band. In case the emission fall within the restricted band specified on 15.205(a), then the 15.209(a) limit in the table below has to be followed.

Restricted Frequency(MHz)	Field Strength (μV/m)	Field Strength (dBμV/m)	Measurement Distance
0.009~0.490	2400/F(KHz)	20 log (uV/m)	300
0.490~1.705	2400/F(KHz)	20 log (uV/m)	30
1.705~30.0	30	29.5	30
30-88	100	40	3
88-216	150	43.5	3
216-960	200	46	3
Above 960	500	54	3

Limits of Radiated Emission Measurement(Above 1000MHz)

Frequency(MHz)	Class B (dBuV/m) (at 3M)	
	PEAK	AVERAGE
Above 1000	74	54

- Remark :1. Emission level in dBuV/m=20 log (uV/m)
 2. Measurement was performed at an antenna to the closed point of EUT distance of meters.
 3. For Frequency 9kHz~30MHz:
 Distance extrapolation factor =40log(Specific distance/ test distance)(dB);
 Limit line=Specific limits(dBuV) + distance extrapolation factor.
 For Frequency above 30MHz:
 Distance extrapolation factor =20log(Specific distance/ test distance)(dB);
 Limit line=Specific limits(dBuV) + distance extrapolation factor.

3.2.3 MEASURING INSTRUMENTS

The Measuring equipment is listed in the section 6.3 of this test report.

3.2.4 TEST CONFIGURATION

(a) For radiated emissions below 30MHz

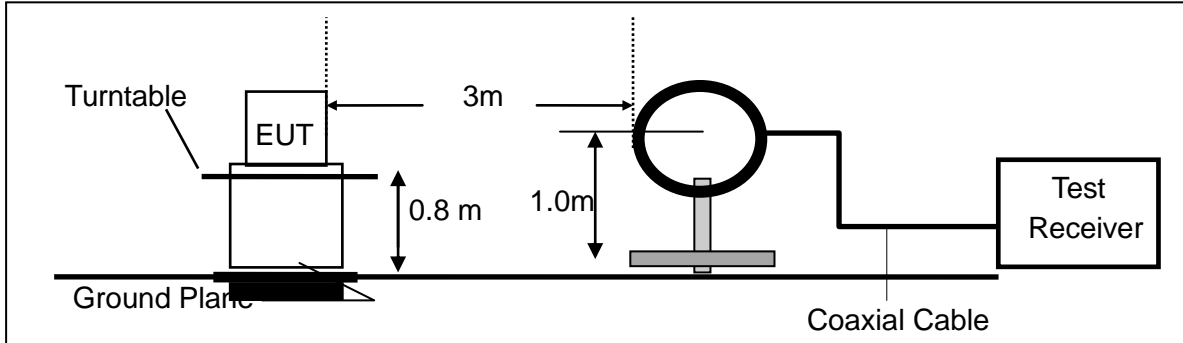

(b) For radiated emissions from 30MHz to 1000MHz

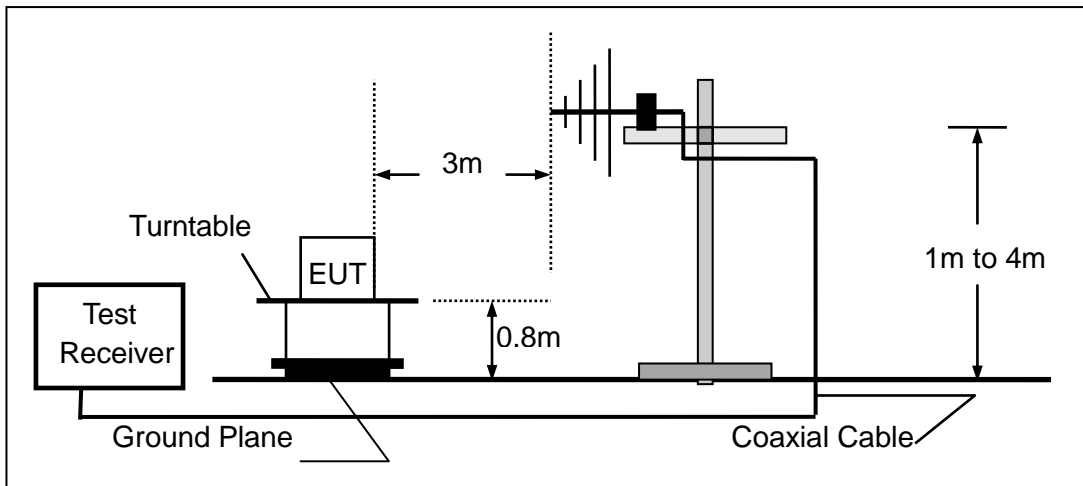

(c) For radiated emissions above 1000MHz

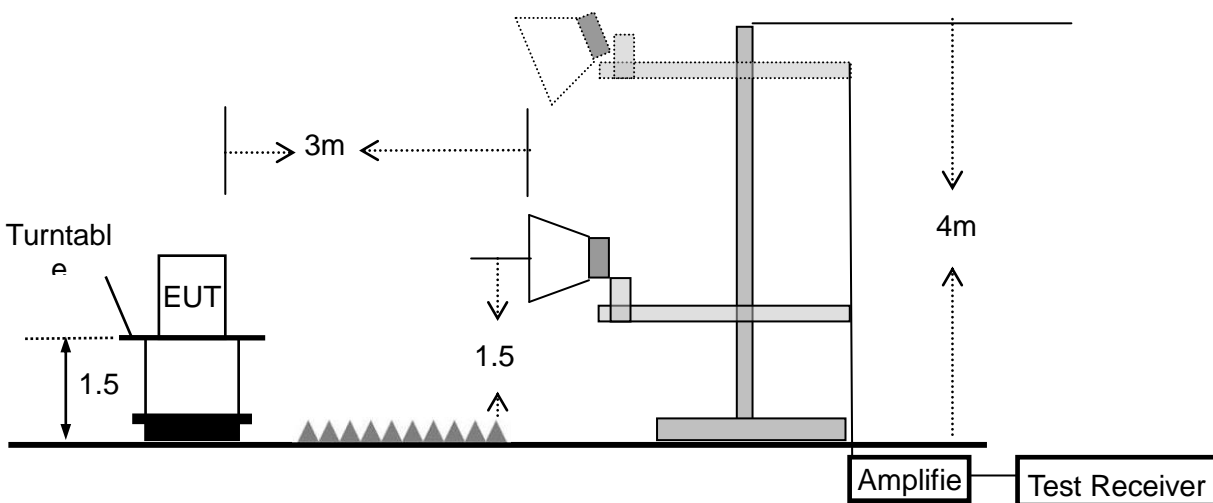

3.2.5 TEST PROCEDURE

The test site semi-anechoic chamber has met the requirement of NSA tolerance 4 dB according to the standards: ANSI C63.10-2013. The test distance is 3m. The setup is according to the requirements in Section 13.1.4.1 of ANSI C63.10-2013 and CAN/CSA-CEI/IEC CISPR 22.

This test is required for any spurious emission that falls in a Restricted Band, as defined in Section 15.205. It must be performed with the highest gain of each type of antenna proposed for use with the EUT.

Use the following spectrum analyzer settings:

Spectrum Parameter	Setting
Attenuation	Auto
Start Frequency	1000 MHz
Stop Frequency	10th carrier harmonic
RB / VB (emission in restricted band)	1 MHz / 1 MHz for Peak, 1 MHz / 10Hz for Average

Receiver Parameter	Setting
Attenuation	Auto
Start ~ Stop Frequency	9kHz~150kHz / RB 200Hz for QP
Start ~ Stop Frequency	150kHz~30MHz / RB 9kHz for QP
Start ~ Stop Frequency	30MHz~1000MHz / RB 120kHz for QP

- The measuring distance of at 3 m shall be used for measurements at frequency up to 1GHz. For frequencies above 1GHz, any suitable measuring distance may be used.
- The EUT was placed on the top of a rotating table 0.8 m for below 1GHz and 1.5m for above 1GHz the ground at a 3 meter. The table was rotated 360 degrees to determine the position of the highest radiation.
- The height of the equipment or of the substitution antenna shall be 0.8 m for below 1GHz and 1.5m for above 1GHz; the height of the test antenna shall vary between 1 m to 4 m. Both horizontal and vertical polarizations of the antenna are set to make the measurement.
- The initial step in collecting conducted emission data is a spectrum analyzer peak detector mode pre-scanning the measurement frequency range. Significant peaks are then marked and then Quasi Peak detector mode re-measured.
- If the Peak Mode measured value compliance with and lower than Quasi Peak Mode Limit, the EUT shall be deemed to meet QP Limits and then no additional QP Mode measurement performed.
- For the actual test configuration, please refer to the related Item –EUT Test Photos.

Note:

Both horizontal and vertical antenna polarities were tested and performed pretest to three orthogonal axis. The worst case emissions were reported

During the radiated emission test, the Spectrum Analyzer was set with the following configurations:

Frequency Band (MHz)	Function	Resolution bandwidth	Video Bandwidth
30 to 1000	QP	120 kHz	300 kHz
Above 1000	Peak	1 MHz	1 MHz
	Average	1 MHz	10 Hz

Note: for the frequency ranges below 30 MHz, a narrower RBW is used for these ranges but the measured value should add a RBW correction factor (RBWCF) where $RBWCF [dB] = 10 \cdot \lg(100 [kHz] / \text{narrower RBW [kHz]})$. , the narrower RBW is 1 kHz and RBWCF is 20 dB for the frequency 9 kHz to 150 kHz, and the narrower RBW is 10 kHz and RBWCF is 10 dB for the frequency 150 kHz to 30 MHz.

3.2.6 TEST RESULTS (9KHZ – 30 MHZ)

EUT:	Wireless Digital Terminal	Model Name. :	S611
Temperature:	20 °C	Relative Humidity:	48%
Pressure:	1010 hPa	Test Voltage :	DC 3.85V
Test Mode :	TX	Polarization :	--

Freq. (MHz)	Reading (dBuV/m)	Limit (dBuV/m)	Margin (dB)	State P/F
--	--	--	--	N/A
--	--	--	--	N/A

NOTE:

The amplitude of spurious emissions which are attenuated by more than 20dB below the permissible value has no need to be reported.

3.2.7 TEST RESULTS (30MHZ – 1GHZ)

EUT :	Wireless Digital Terminal	Model Name. :	S611
Temperature :	20 °C	Relative Humidity :	48%
Pressure :	1010 hPa	Test Voltage :	DC 3.85V
Test Mode :	TX(5.2G)- 802.11a (High CH)		

Polar (H/V)	Frequency	Meter Reading	Factor	Emission Level	Limits	Margin	Remark
	(MHz)	(dBuV)	(dB)	(dBuV/m)	(dBuV/m)	(dB)	
V	33.4448	6.54	17.42	23.96	40.00	-16.04	QP
V	46.9947	9.69	11.28	20.97	40.00	-19.03	QP
V	68.3906	14.99	6.58	21.57	40.00	-18.43	QP
V	133.1511	10.68	13.41	24.09	43.50	-19.41	QP
V	752.7432	6.50	27.51	34.01	46.00	-11.99	QP
V	965.5421	5.39	31.22	36.61	54.00	-17.39	QP

Remark:

Absolute Level= ReadingLevel+ Factor, Margin= Absolute Level - Limit

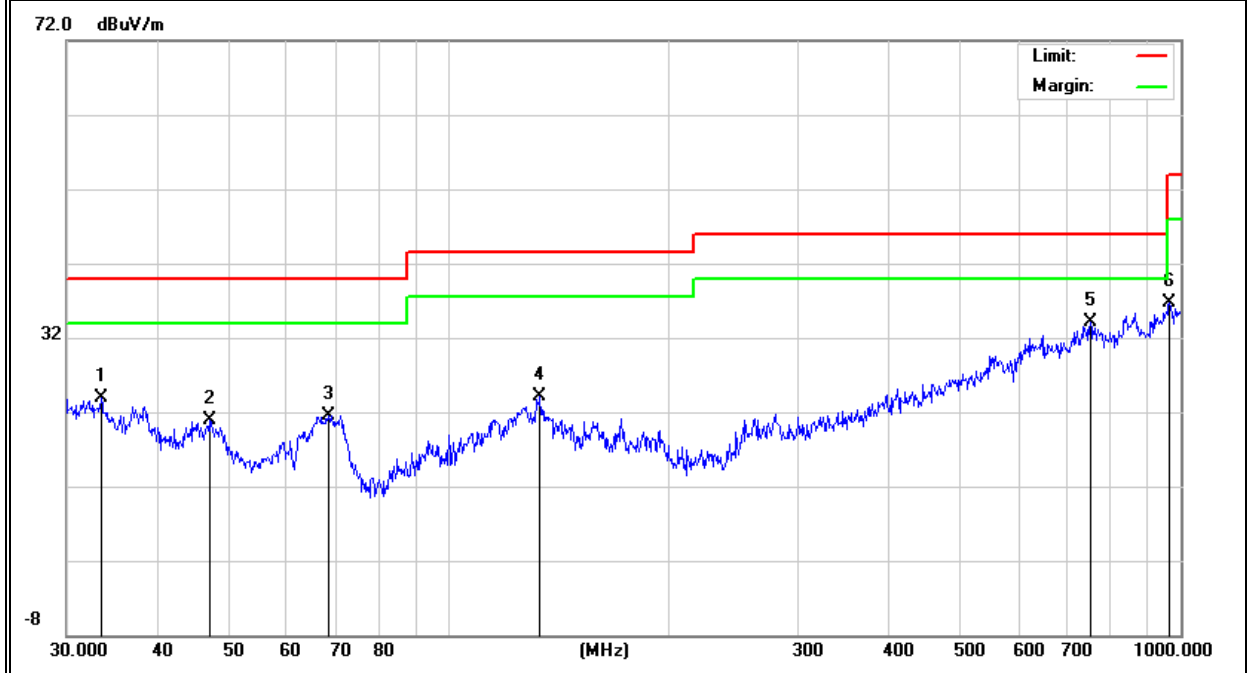

Polar (H/V)	Frequency	Meter Reading	Factor	Emission Level	Limits	Margin	Remark
	(MHz)	(dBuV)	(dB)	(dBuV/m)	(dBuV/m)	(dB)	
H	34.7601	9.37	16.82	26.19	40.00	-13.81	QP
H	130.8369	8.74	13.44	22.18	43.50	-21.32	QP
H	148.9625	10.08	12.84	22.92	43.50	-20.58	QP
H	311.0867	10.51	16.36	26.87	46.00	-19.13	QP
H	499.4245	10.36	22.14	32.50	46.00	-13.50	QP
H	945.4397	6.37	31.01	37.38	46.00	-8.62	QP

Remark:

Absolute Level= ReadingLevel+ Factor, Margin= Absolute Level - Limit

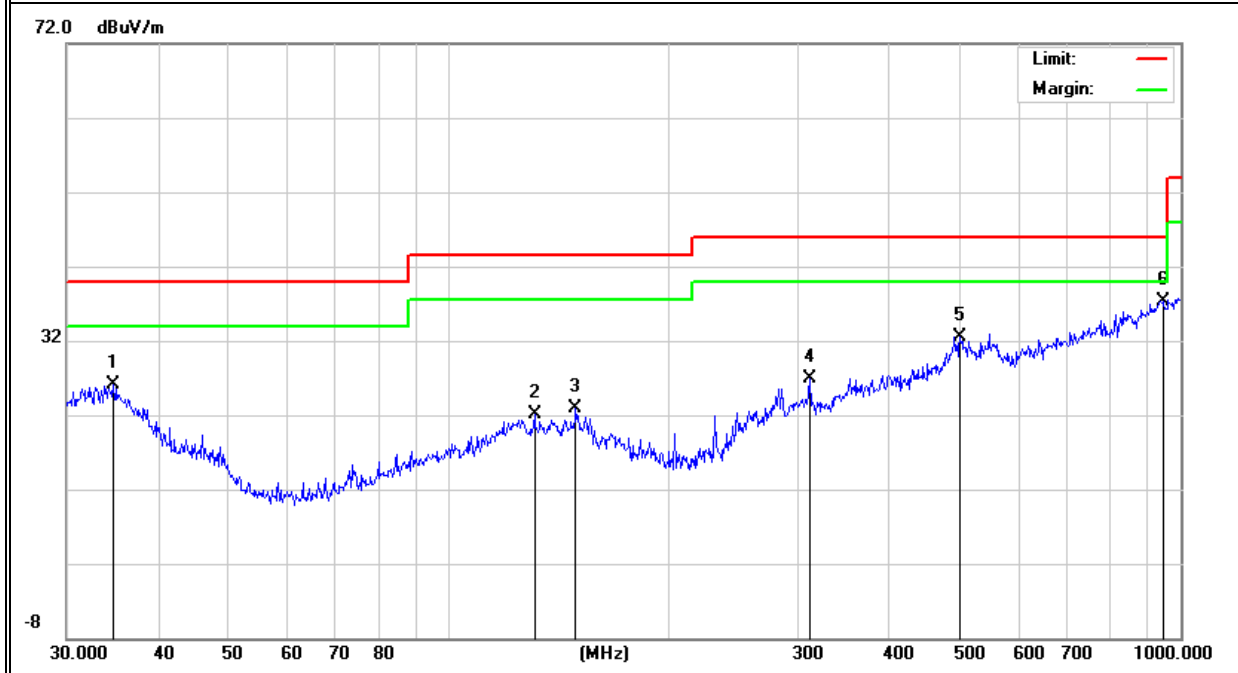

EUT :	Wireless Digital Terminal	Model Name. :	S611
Temperature :	20 °C	Relative Humidity :	48%
Pressure :	1010 hPa	Test Voltage :	DC 3.85V
Test Mode :	TX(5.3G)- 802.11a (High CH)		

Polar (H/V)	Frequency	Meter Reading	Factor	Emission Level	Limits	Margin	Remark
	(MHz)	(dBuV)	(dB)	(dBuV/m)	(dBuV/m)	(dB)	
V	32.0667	10.98	18.16	29.14	40.00	-10.86	QP
V	38.0782	14.14	15.21	29.35	40.00	-10.65	QP
V	66.0340	23.37	6.55	29.92	40.00	-10.08	QP
V	125.4457	18.05	13.33	31.38	43.50	-12.12	QP
V	196.5098	19.16	9.81	28.97	43.50	-14.53	QP
V	942.1304	11.23	30.93	42.16	46.00	-3.84	QP

Remark:

Absolute Level= ReadingLevel+ Factor, Margin= Absolute Level - Limit

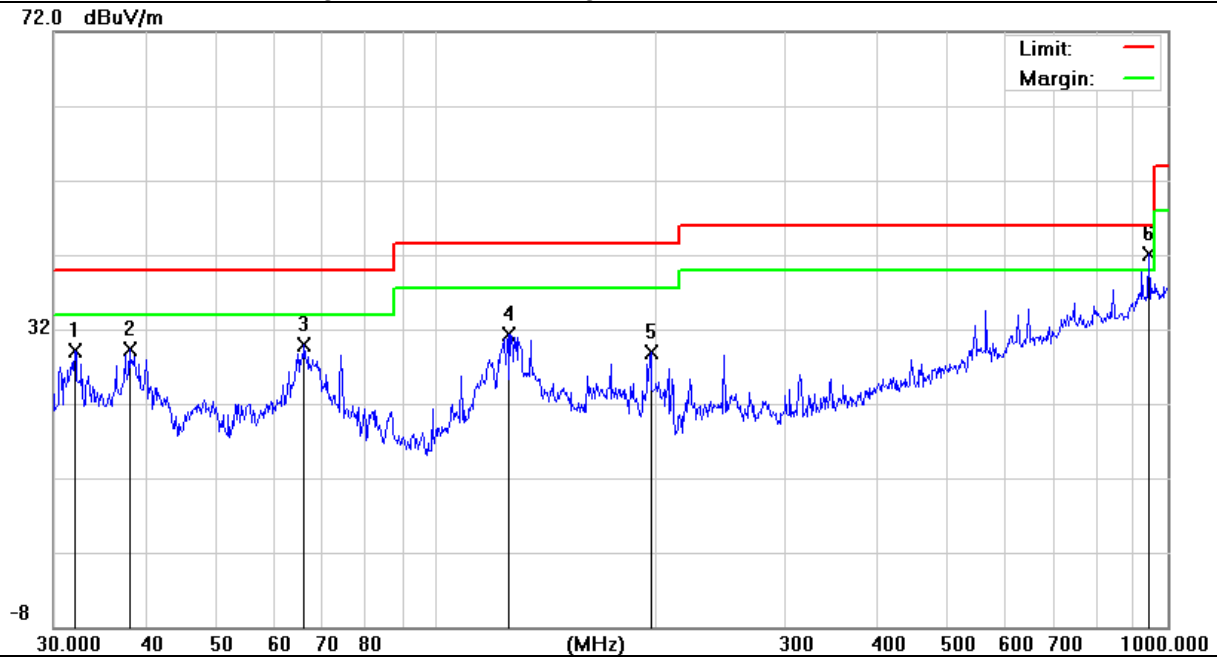

Polar (H/V)	Frequency	Meter Reading	Factor	Emission Level	Limits	Margin	Remark
	(MHz)	(dBuV)	(dB)	(dBuV/m)	(dBuV/m)	(dB)	
H	123.6984	13.09	13.28	26.37	43.50	-17.13	QP
H	173.2050	17.79	11.00	28.79	43.50	-14.71	QP
H	207.8497	23.32	10.83	34.15	43.50	-9.35	QP
H	247.6819	21.59	14.50	36.09	46.00	-9.91	QP
H	346.8091	12.68	17.56	30.24	46.00	-15.76	QP
H	942.1304	11.56	30.93	42.49	46.00	-3.51	QP

Remark:

Absolute Level= ReadingLevel+ Factor, Margin= Absolute Level - Limit

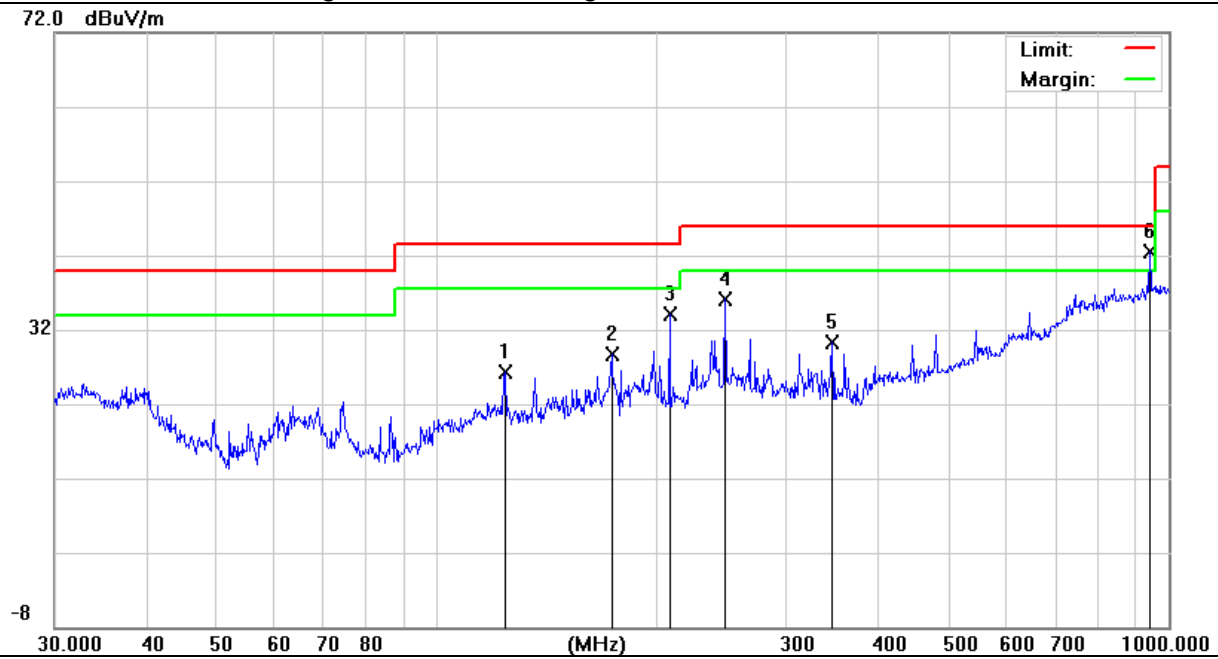

EUT :	Wireless Digital Terminal	Model Name. :	S611
Temperature :	20 °C	Relative Humidity :	48%
Pressure :	1010 hPa	Test Voltage :	DC 3.85V
Test Mode :	TX(5.6G)- 802.11a (High CH)		

Polar (H/V)	Frequency	Meter Reading	Factor	Emission Level	Limits	Margin	Remark
	(MHz)	(dBuV)	(dB)	(dBuV/m)	(dBuV/m)	(dB)	
V	32.8637	10.74	17.72	28.46	40.00	-11.54	QP
V	53.5052	18.24	7.67	25.91	40.00	-14.09	QP
V	128.1125	17.42	13.40	30.82	43.50	-12.68	QP
V	170.1947	15.86	11.34	27.20	43.50	-16.30	QP
V	254.7281	11.88	15.23	27.11	46.00	-18.89	QP
V	314.3765	10.51	16.41	26.92	46.00	-19.08	QP

Remark:

Absolute Level= ReadingLevel+ Factor, Margin= Absolute Level - Limit

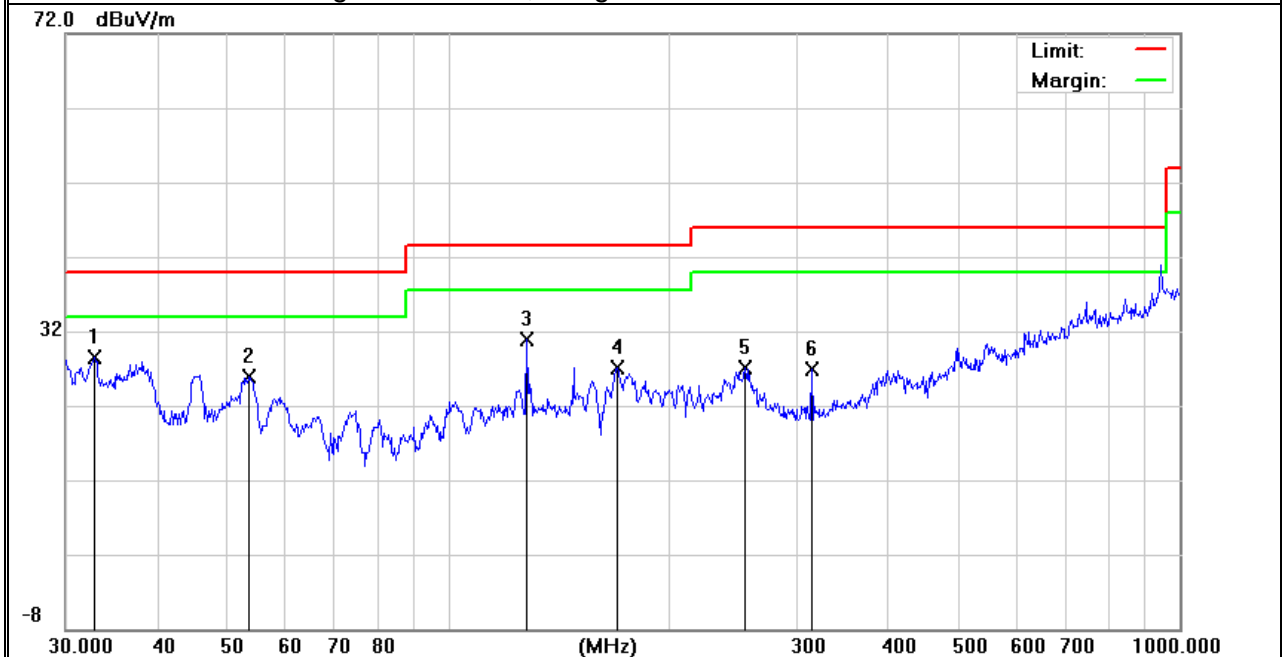

Polar (H/V)	Frequency	Meter Reading	Factor	Emission Level	Limits	Margin	Remark
	(MHz)	(dBuV)	(dB)	(dBuV/m)	(dBuV/m)	(dB)	
H	31.7313	7.07	18.28	25.35	40.00	-14.65	QP
H	102.7192	11.12	11.97	23.09	43.50	-20.41	QP
H	148.4410	11.35	12.88	24.23	43.50	-19.27	QP
H	247.6819	11.98	14.50	26.48	46.00	-19.52	QP
H	387.9920	13.08	18.92	32.00	46.00	-14.00	QP
H	744.8659	9.64	27.55	37.19	46.00	-8.81	QP

Remark:

Absolute Level= ReadingLevel+ Factor, Margin= Absolute Level - Limit

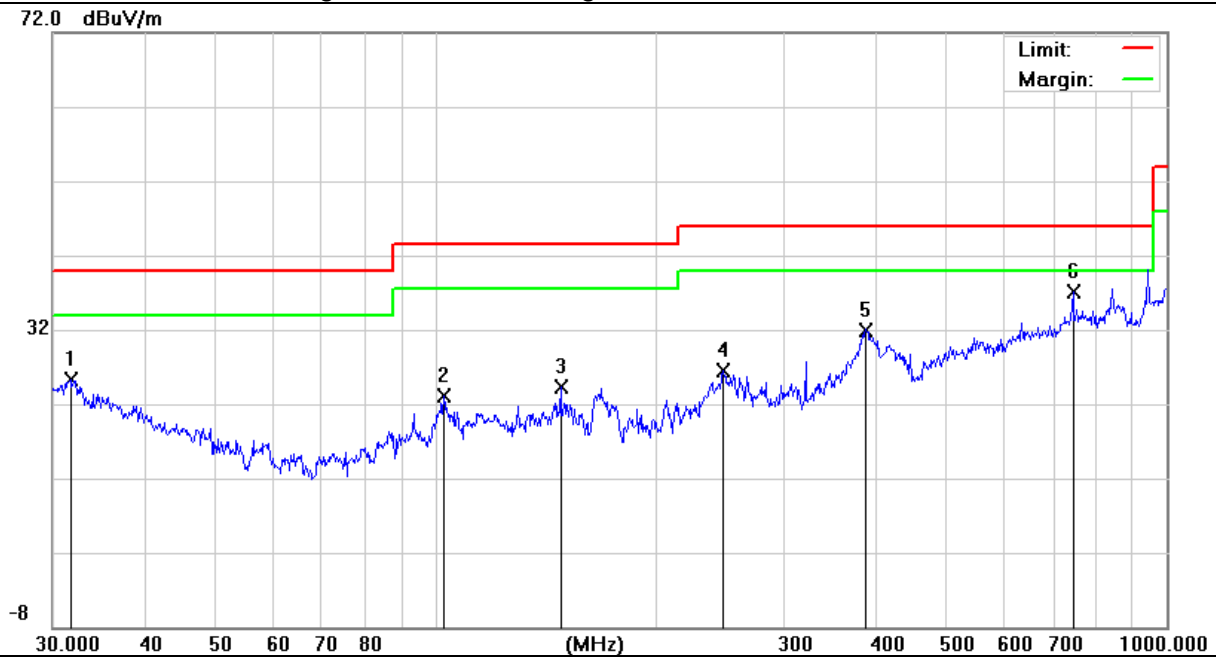

EUT :	Wireless Digital Terminal	Model Name. :	S611
Temperature :	20 °C	Relative Humidity :	48%
Pressure :	1010 hPa	Test Voltage :	DC 3.85V
Test Mode :	TX(5.8G) - 802.11a (High CH)		

Polar (H/V)	Frequency	Meter Reading	Factor	Emission Level	Limits	Margin	Remark
	(MHz)	(dBuV)	(dB)	(dBuV/m)	(dBuV/m)	(dB)	
V	33.4448	10.04	17.42	27.46	40.00	-12.54	QP
V	44.5867	11.84	11.80	23.64	40.00	-16.36	QP
V	71.3298	15.80	6.82	22.62	40.00	-17.38	QP
V	123.6984	12.18	13.28	25.46	43.50	-18.04	QP
V	752.7432	6.50	27.51	34.01	46.00	-11.99	QP
V	866.0878	7.20	28.65	35.85	46.00	-10.15	QP

Remark:

Absolute Level= ReadingLevel+ Factor, Margin= Absolute Level - Limit

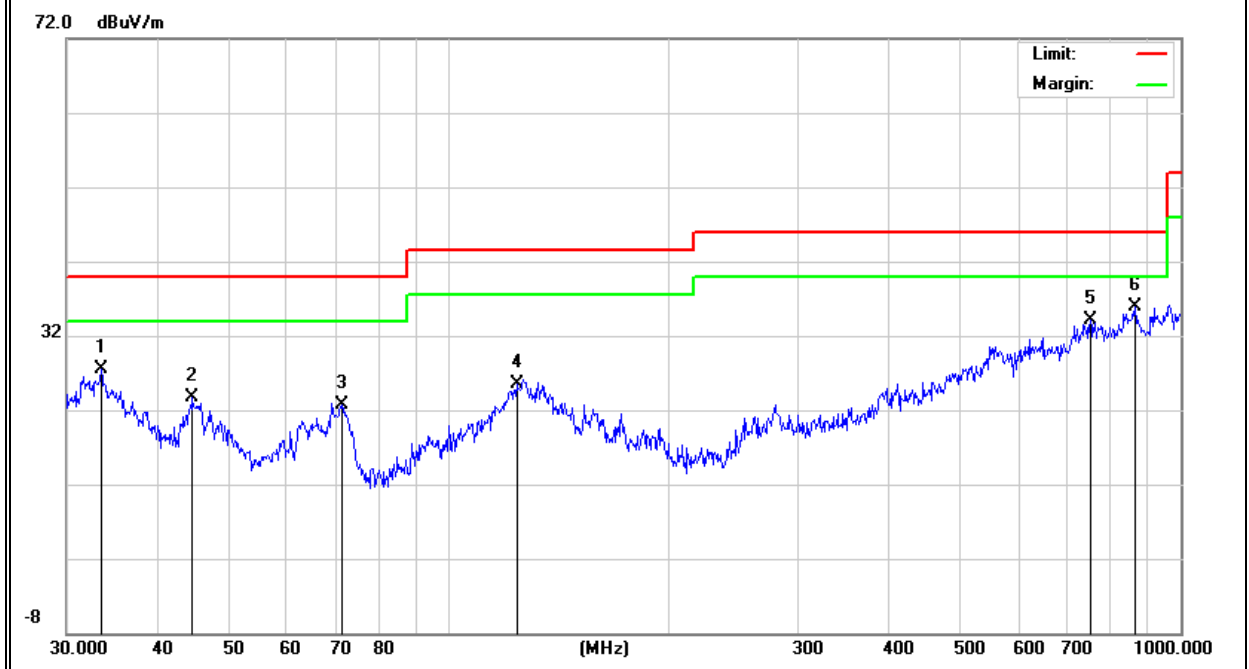

Polar (H/V)	Frequency	Meter Reading	Factor	Emission Level	Limits	Margin	Remark
	(MHz)	(dBuV)	(dB)	(dBuV/m)	(dBuV/m)	(dB)	
H	32.1794	7.60	18.10	25.70	40.00	-14.30	QP
H	137.9028	8.88	13.33	22.21	43.50	-21.29	QP
H	155.9096	10.64	12.35	22.99	43.50	-20.51	QP
H	311.0867	10.51	16.36	26.87	46.00	-19.13	QP
H	547.0977	8.71	24.29	33.00	46.00	-13.00	QP
H	909.6666	7.86	29.53	37.39	46.00	-8.61	QP

Remark:

Absolute Level= ReadingLevel+ Factor, Margin= Absolute Level - Limit

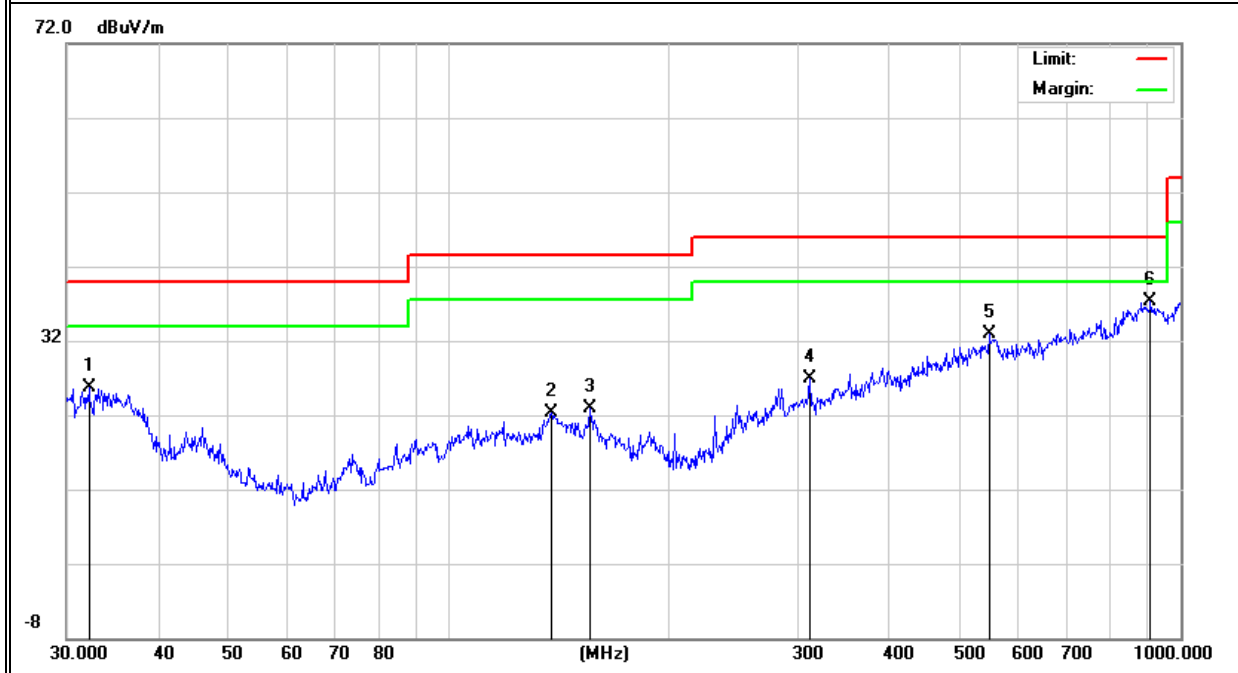

3.2.8 TEST RESULTS (1GHz-18GHz)

EUT :	Wireless Digital Terminal	Model Name. :	S611
Temperature :	20 °C	Relative Humidity :	48%
Pressure :	1010 hPa	Test Voltage :	DC 3.85V
Test Mode :	TX(5.2G) - 802.11a_5180~5240MHz		

Polar	Frequency	Meter Reading	Cable loss	Antenna Factor	Preamp Factor	Emission Level	Limits	Margin	Detector Type
(H/V)	(MHz)	(dBuV)	(dB)	dB/m	(dB)	(dBuV/m)	(dBuV/m)	(dB)	
Low Channel (5180 MHz)-Above 1G									
Vertical	4436.02	59.76	5.94	35.40	44.00	57.10	74.00	-16.90	Pk
Vertical	4436.02	40.97	5.94	35.40	44.00	38.31	54.00	-15.69	AV
Vertical	10371.07	62.62	8.46	39.75	44.50	66.33	74.00	-7.67	Pk
Vertical	10371.07	40.91	8.46	39.75	44.50	44.62	54.00	-9.38	AV
Vertical	15541.58	58.57	10.12	38.80	44.10	63.39	74.00	-10.61	Pk
Vertical	15541.58	37.82	10.12	38.80	42.70	44.04	54.00	-9.96	AV
Horizontal	4434.74	62.85	5.94	35.18	44.00	59.97	74.00	-14.03	Pk
Horizontal	4434.74	42.49	5.94	35.18	44.00	39.61	54.00	-14.39	AV
Horizontal	10370.26	57.15	8.46	38.71	44.50	59.82	74.00	-14.18	Pk
Horizontal	10370.26	40.60	8.46	38.71	44.50	43.27	54.00	-10.73	AV
Horizontal	10541.28	55.18	10.12	38.38	44.10	59.58	74.00	-14.42	Pk
Horizontal	10541.28	39.42	10.12	38.38	44.10	43.82	54.00	-10.18	AV
Middle Channel (5200 MHz)-Above 1G									
Vertical	4592.89	57.24	6.48	36.35	44.05	56.02	74.00	-17.98	Pk
Vertical	4592.89	40.31	6.48	36.35	44.05	39.09	54.00	-14.91	AV
Vertical	10401.29	58.47	8.47	37.88	44.51	60.31	74.00	-13.69	Pk
Vertical	10401.29	40.05	8.47	37.88	44.51	41.89	54.00	-12.11	AV
Vertical	15601.19	58.71	10.12	38.80	44.10	63.53	74.00	-10.47	Pk
Vertical	15601.19	37.64	10.12	38.80	42.70	43.86	54.00	-10.14	AV
Horizontal	4592.90	56.62	6.48	36.37	44.05	55.42	74.00	-18.58	Pk
Horizontal	4592.90	42.43	6.48	36.37	44.05	41.23	54.00	-12.77	AV
Horizontal	10400.79	60.27	8.47	38.64	44.50	62.88	74.00	-11.12	Pk
Horizontal	10400.79	38.44	8.47	38.64	44.50	41.05	54.00	-12.95	AV
Horizontal	15600.43	57.40	10.12	38.38	44.10	61.80	74.00	-12.20	Pk
Horizontal	15600.43	38.81	10.12	38.38	44.10	43.21	54.00	-10.79	AV
High Channel (5240 MHz)-Above 1G									
Vertical	4739.93	61.88	7.10	37.24	43.50	62.72	74.00	-11.28	Pk
Vertical	4739.93	41.19	7.10	37.24	43.50	42.03	54.00	-11.97	AV
Vertical	10480.87	59.04	8.46	37.68	44.50	60.68	74.00	-13.32	Pk
Vertical	10480.87	39.50	8.46	37.68	44.50	41.14	54.00	-12.86	AV
Vertical	15721.34	60.04	10.12	38.80	44.10	64.86	74.00	-9.14	Pk
Vertical	15721.34	36.95	10.12	38.80	42.70	43.17	54.00	-10.83	AV
Horizontal	4739.53	60.21	7.10	37.24	43.50	61.05	74.00	-12.95	Pk
Horizontal	4739.53	39.05	7.10	37.24	43.50	39.89	54.00	-14.11	AV
Horizontal	10482.12	59.68	8.46	38.57	44.50	62.21	74.00	-11.79	Pk
Horizontal	10482.12	41.42	8.46	38.57	44.50	43.95	54.00	-10.05	AV
Horizontal	15721.32	57.81	10.12	38.38	44.10	62.21	74.00	-11.79	Pk
Horizontal	15721.32	42.17	10.12	38.38	44.10	46.57	54.00	-7.43	AV

Note:"802.11a(5G)" mode is the worst mode. PK value is lower than the Average value limit, So average didn't record.

The amplitude of spurious emissions that are attenuated by more than 20dB below the permissible value has no need to be reported.

Emission level (dBuV/m) = 20 log Emission level (uV/m).

Corrected Reading: Antenna Factor + Cable Loss + Read Level - Preamp Factor = Level

EUT :	Wireless Digital Terminal	Model Name. :	S611
Temperature :	20 °C	Relative Humidity :	48%
Pressure :	1010 hPa	Test Voltage :	DC 3.85V
Test Mode :	TX(5.3G) - 802.11a_5260~5320MHz		

Polar	Frequency	Meter Reading	Cable loss	Antenna Factor	Preamp Factor	Emission Level	Limits	Margin	Detector Type
(H/V)	(MHz)	(dBuV)	(dB)	dB/m	(dB)	(dBuV/m)	(dBuV/m)	(dB)	
Low Channel (5260 MHz)-Above 1G									
Vertical	4633.25	61.84	5.44	35.40	44.00	58.69	74.00	-15.31	Pk
Vertical	4633.25	43.32	5.74	35.40	44.00	40.46	54.00	-13.54	AV
Vertical	10520.12	63.02	8.26	39.75	44.50	66.53	74.00	-7.47	Pk
Vertical	10520.12	42.53	8.01	39.75	44.50	45.79	54.00	-8.21	AV
Vertical	15780.34	60.60	10.12	38.80	44.10	65.42	74.00	-8.58	Pk
Vertical	15780.34	39.47	9.62	38.80	42.70	45.19	54.00	-8.81	AV
Horizontal	4366.15	63.99	5.57	35.18	44.00	60.73	74.00	-13.27	Pk
Horizontal	4366.15	43.25	5.74	35.18	44.00	40.17	54.00	-13.83	AV
Horizontal	10520.26	59.06	8.38	38.71	44.50	61.65	74.00	-12.35	Pk
Horizontal	10520.26	42.13	8.45	38.71	44.50	44.79	54.00	-9.21	AV
Horizontal	15780.34	57.21	9.88	38.38	44.10	61.37	74.00	-12.63	Pk
Horizontal	15780.34	40.21	9.94	38.38	44.10	44.43	54.00	-9.57	AV
middle Channel (5280 MHz)-Above 1G									
Vertical	4122.34	58.65	6.08	36.35	44.05	57.03	74.00	-16.97	Pk
Vertical	4122.34	42.28	6.39	36.35	44.05	40.97	54.00	-13.03	AV
Vertical	10560.19	59.39	8.28	37.88	44.51	61.04	74.00	-12.96	Pk
Vertical	10560.19	42.30	7.99	37.88	44.51	43.67	54.00	-10.33	AV
Vertical	15840.36	61.12	9.79	38.8	44.10	65.60	74.00	-8.40	Pk
Vertical	15840.36	39.27	9.70	38.8	42.70	45.07	54.00	-8.93	AV
Horizontal	3869.48	58.39	6.11	36.37	44.05	56.82	74.00	-17.18	Pk
Horizontal	3869.48	45.70	6.27	36.37	44.05	44.29	54.00	-9.71	AV
Horizontal	10560.74	61.87	8.33	38.64	44.50	64.34	74.00	-9.66	Pk
Horizontal	10560.74	40.77	8.07	38.64	44.50	42.97	54.00	-11.03	AV
Horizontal	15840.37	59.89	9.99	38.38	44.10	64.16	74.00	-9.84	Pk
Horizontal	15840.37	40.51	9.81	38.38	44.10	44.60	54.00	-9.40	AV
High Channel (5320 MHz)-Above 1G									
Vertical	5366.52	62.07	6.96	37.24	43.50	62.77	74.00	-11.23	Pk
Vertical	5366.52	43.07	7.07	37.24	43.50	43.87	54.00	-10.13	AV
Vertical	10640.58	61.46	8.14	37.68	44.50	62.78	74.00	-11.22	Pk
Vertical	10640.58	41.18	8.35	37.68	44.50	42.71	54.00	-11.29	AV
Vertical	15960.41	60.26	10.11	38.80	44.10	65.06	74.00	-8.94	Pk
Vertical	15960.41	38.54	9.64	38.80	42.70	44.29	54.00	-9.71	AV
Horizontal	5436.59	61.04	7.05	37.24	43.50	61.83	74.00	-12.17	Pk
Horizontal	5436.59	41.31	7.05	37.24	43.50	42.10	54.00	-11.90	AV
Horizontal	10640.24	60.24	8.20	38.57	44.50	62.51	74.00	-11.49	Pk
Horizontal	10640.24	42.99	8.03	38.57	44.50	45.09	54.00	-8.91	AV
Horizontal	15960.88	59.96	9.81	38.38	44.10	64.06	74.00	-9.94	Pk
Horizontal	15960.88	42.99	9.96	38.38	44.10	47.23	54.00	-6.77	AV

Note:"802.11a(5G)" mode is the worst mode. PK value is lower than the Average value limit, So average didn't record.

The amplitude of spurious emissions that are attenuated by more than 20dB below the permissible value has no need to be reported.

Emission level (dBuV/m) = 20 log Emission level (uV/m).

Corrected Reading: Antenna Factor + Cable Loss + Read Level - Preamp Factor = Level

EUT :	Wireless Digital Terminal	Model Name. :	S611
Temperature :	20 °C	Relative Humidity :	48%
Pressure :	1010 hPa	Test Voltage :	DC 3.85V
Test Mode :	TX (5.6G) -- 802.11a _5500~5700MHz		

Polar	Frequency	Meter Reading	Cable loss	Antenna Factor	Preamp Factor	Emission Level	Limits	Margin	Detector Type
(H/V)	(MHz)	(dBuV)	(dB)	dB/m	(dB)	(dBuV/m)	(dBuV/m)	(dB)	
Low Channel (5500 MHz)-Above 1G									
Vertical	5433.02	63.28	5.61	35.40	44.00	60.29	74.00	-13.71	Pk
Vertical	5433.02	44.11	5.76	35.40	44.00	41.27	54.00	-12.73	AV
Vertical	11000.25	59.05	8.24	39.75	44.50	62.54	74.00	-11.46	Pk
Vertical	11000.25	40.91	8.35	39.75	44.50	44.51	54.00	-9.49	AV
Vertical	16500.41	50.04	10.05	38.80	44.10	54.79	74.00	-19.21	Pk
Vertical	16500.41	41.79	9.65	38.80	42.70	47.54	54.00	-6.46	AV
Horizontal	5126.47	59.57	5.78	35.18	44.00	56.53	74.00	-17.47	Pk
Horizontal	5126.47	41.52	5.66	35.18	44.00	38.37	54.00	-15.63	AV
Horizontal	11000.32	57.25	8.22	38.71	44.50	59.68	74.00	-14.32	Pk
Horizontal	11000.32	40.61	8.14	38.71	44.50	42.96	54.00	-11.04	AV
Horizontal	16500.47	60.88	10.04	38.38	44.10	65.20	74.00	-8.80	Pk
Horizontal	16500.47	38.63	9.73	38.38	44.10	42.64	54.00	-11.36	AV
Middle Channel (5600 MHz)-Above 1G									
Vertical	4933.25	61.71	6.29	36.35	44.05	60.29	74.00	-13.71	Pk
Vertical	4933.25	43.27	6.24	36.35	44.05	41.81	54.00	-12.19	AV
Vertical	11200.58	58.92	8.24	37.88	44.51	60.54	74.00	-13.46	Pk
Vertical	11200.58	43.55	8.13	37.88	44.51	45.04	54.00	-8.96	AV
Vertical	16800.45	58.95	9.71	38.80	44.10	63.36	74.00	-10.64	Pk
Vertical	16800.45	39.82	10.12	38.80	42.70	46.03	54.00	-7.97	AV
Horizontal	4766.32	59.50	6.44	36.37	44.05	58.26	74.00	-15.74	Pk
Horizontal	4766.32	42.44	6.13	36.37	44.05	40.90	54.00	-13.10	AV
Horizontal	11200.45	59.89	8.31	38.64	44.50	62.34	74.00	-11.66	Pk
Horizontal	11200.45	42.13	8.04	38.64	44.50	44.31	54.00	-9.69	AV
Horizontal	16800.33	61.21	10.09	38.38	44.10	65.58	74.00	-8.42	Pk
Horizontal	16800.33	41.16	9.63	38.38	44.10	45.07	54.00	-8.93	AV
High Channel (5700 MHz)-Above 1G									
Vertical	5647.33	61.04	6.79	37.24	43.50	61.57	74.00	-12.43	Pk
Vertical	5647.33	41.65	6.85	37.24	43.50	42.24	54.00	-11.76	AV
Vertical	11400.29	60.29	8.10	37.68	44.50	61.57	74.00	-12.43	Pk
Vertical	11400.29	41.64	8.23	37.68	44.50	43.05	54.00	-10.95	AV
Vertical	17100.54	61.10	9.70	38.80	44.10	65.51	74.00	-8.49	Pk
Vertical	17100.54	39.78	9.70	38.80	42.70	45.58	54.00	-8.42	AV
Horizontal	5433.26	59.90	6.74	37.24	43.50	60.38	74.00	-13.62	Pk
Horizontal	5433.26	41.77	6.74	37.24	43.50	42.25	54.00	-11.75	AV
Horizontal	11400.43	59.39	8.25	38.57	44.50	61.71	74.00	-12.29	Pk
Horizontal	11400.43	41.30	8.35	38.57	44.50	43.72	54.00	-10.28	AV
Horizontal	17100.58	58.49	9.70	38.38	44.10	62.47	74.00	-11.53	Pk
Horizontal	17100.58	41.04	9.63	38.38	44.10	44.95	54.00	-9.05	AV

Note:"802.11a(5G)" mode is the worst mode. PK value is lower than the Average value limit, So average didn't record.

The amplitude of spurious emissions that are attenuated by more than 20dB below the permissible value has no need to be reported.

Emission level (dBuV/m) = 20 log Emission level (uV/m).

Corrected Reading: Antenna Factor + Cable Loss + Read Level - Preamp Factor = Level.

EUT :	Wireless Digital Terminal	Model Name. :	S611
Temperature :	20 °C	Relative Humidity :	48%
Pressure :	1010 hPa	Test Voltage :	DC 3.85V
Test Mode :	TX (5.8G) -- 802.11a_5745~5825MHz		

Polar	Frequency	Meter Reading	Cable loss	Antenna Factor	Preamp Factor	Emission Level	Limits	Margin	Detector Type
(H/V)	(MHz)	(dBuV)	(dB)	dB/m	(dB)	(dBuV/m)	(dBuV/m)	(dB)	
Low Channel (5745 MHz)-Above 1G									
Vertical	4681.13	60.98	5.94	35.40	44.00	58.32	74.00	-15.68	Pk
Vertical	4681.13	41.84	5.94	35.40	44.00	39.18	54.00	-14.82	AV
Vertical	11491.14	57.90	8.46	39.75	44.50	61.61	74.00	-12.39	Pk
Vertical	11491.14	40.29	8.46	39.75	44.50	44.00	54.00	-10.00	AV
Vertical	17235.87	48.77	10.12	38.80	44.10	53.59	74.00	-20.41	Pk
Vertical	17235.87	39.05	10.12	38.80	42.70	45.27	54.00	-8.73	AV
Horizontal	4680.27	58.27	5.94	35.18	44.00	55.39	74.00	-18.61	Pk
Horizontal	4680.27	38.77	5.94	35.18	44.00	35.89	54.00	-18.11	AV
Horizontal	11491.17	56.57	8.46	38.71	44.50	59.24	74.00	-14.76	Pk
Horizontal	11491.17	39.62	8.46	38.71	44.50	42.29	54.00	-11.71	AV
Horizontal	17235.41	59.78	10.12	38.38	44.10	64.18	74.00	-9.82	Pk
Horizontal	17235.41	38.41	10.12	38.38	44.10	42.81	54.00	-11.19	AV
middle Channel (5785 MHz)-Above 1G									
Vertical	4592.86	60.00	6.48	36.35	44.05	58.78	74.00	-15.22	Pk
Vertical	4592.86	40.65	6.48	36.35	44.05	39.43	54.00	-14.57	AV
Vertical	11570.55	57.08	8.47	37.88	44.51	58.92	74.00	-15.08	Pk
Vertical	11570.55	40.62	8.47	37.88	44.51	42.46	54.00	-11.54	AV
Vertical	17356.00	58.59	10.12	38.80	44.10	63.41	74.00	-10.59	Pk
Vertical	17356.00	38.19	10.12	38.80	42.70	44.41	54.00	-9.59	AV
Horizontal	4592.92	56.88	6.48	36.37	44.05	55.68	74.00	-18.32	Pk
Horizontal	4592.92	41.71	6.48	36.37	44.05	40.51	54.00	-13.49	AV
Horizontal	11570.33	59.78	8.47	38.64	44.50	62.39	74.00	-11.61	Pk
Horizontal	11570.33	41.54	8.47	38.64	44.50	44.15	54.00	-9.85	AV
Horizontal	17356.07	59.42	10.12	38.38	44.10	63.82	74.00	-10.18	Pk
Horizontal	17356.07	39.89	10.12	38.38	44.10	44.29	54.00	-9.71	AV
High Channel (5825 MHz)-Above 1G									
Vertical	6040.62	61.15	7.10	37.24	43.50	61.99	74.00	-12.01	Pk
Vertical	6040.62	40.24	7.10	37.24	43.50	41.08	54.00	-12.92	AV
Vertical	11652.58	59.37	8.46	37.68	44.50	61.01	74.00	-12.99	Pk
Vertical	11652.58	41.19	8.46	37.68	44.50	42.83	54.00	-11.17	AV
Vertical	17473.96	58.95	10.12	38.80	44.10	63.77	74.00	-10.23	Pk
Vertical	17473.96	39.40	10.12	38.80	42.70	45.62	54.00	-8.38	AV
Horizontal	6040.50	58.55	7.10	37.24	43.50	59.39	74.00	-14.61	Pk
Horizontal	6040.50	40.52	7.10	37.24	43.50	41.36	54.00	-12.64	AV
Horizontal	11652.98	57.80	8.46	38.57	44.50	60.33	74.00	-13.67	Pk
Horizontal	11652.98	39.84	8.46	38.57	44.50	42.37	54.00	-11.63	AV
Horizontal	17475.08	56.64	10.12	38.38	44.10	61.04	74.00	-12.96	Pk
Horizontal	17475.08	38.62	10.12	38.38	44.10	43.02	54.00	-10.98	AV

Note:"802.11a(5G)" mode is the worst mode. PK value is lower than the Average value limit, So average didn't record.

The amplitude of spurious emissions that are attenuated by more than 20dB below the permissible value has no need to be reported.

Emission level (dBuV/m) = 20 log Emission level (uV/m).

Corrected Reading: Antenna Factor + Cable Loss + Read Level - Preamp Factor = Level.

3.2.9 TEST RESULTS (18GHZ-40GHZ)

EUT :	Wireless Digital Terminal	Model Name. :	S611
Temperature :	20 °C	Relative Humidity :	48%
Pressure :	1010 hPa	Test Voltage :	DC 3.85V
Test Mode :	TX (5.2G)-802.11a 5180MHz~5240MHz; TX (5.3G)-802.11a 5260MHz~5320MHz; TX (5.6G)-802.11a 5500MHz~5700MHz; TX (5.8G)-802.11a 5745MHz~5825MHz		

All the modulation modes have been tested, and the worst result was report as below:

Low Channel (5180 MHz)-Above 1G
Horizontal

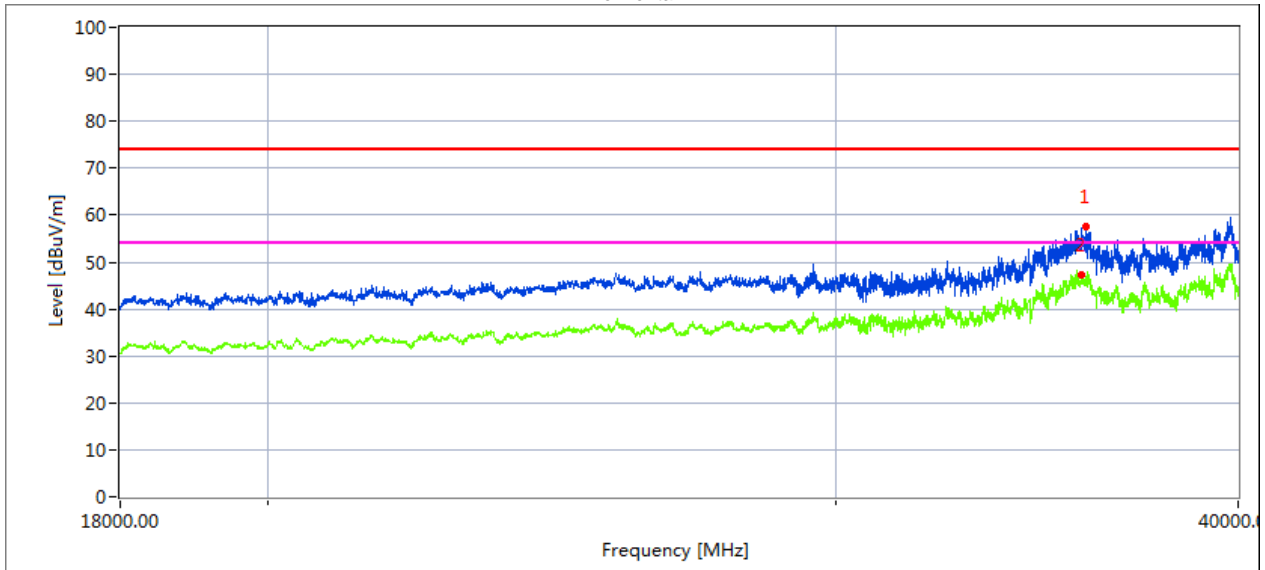

Measurement Result:

Frequency MHz	Pre-scan Level MaxPeak dBuV/m	Final Test Level MaxPeak dBuV/m	Limit MaxPeak dBuV/m	Margin dB
35871.038	57.5	51.6	74.0	22.4
35779.048	48.2	43.8	54.0	10.2

Vertical

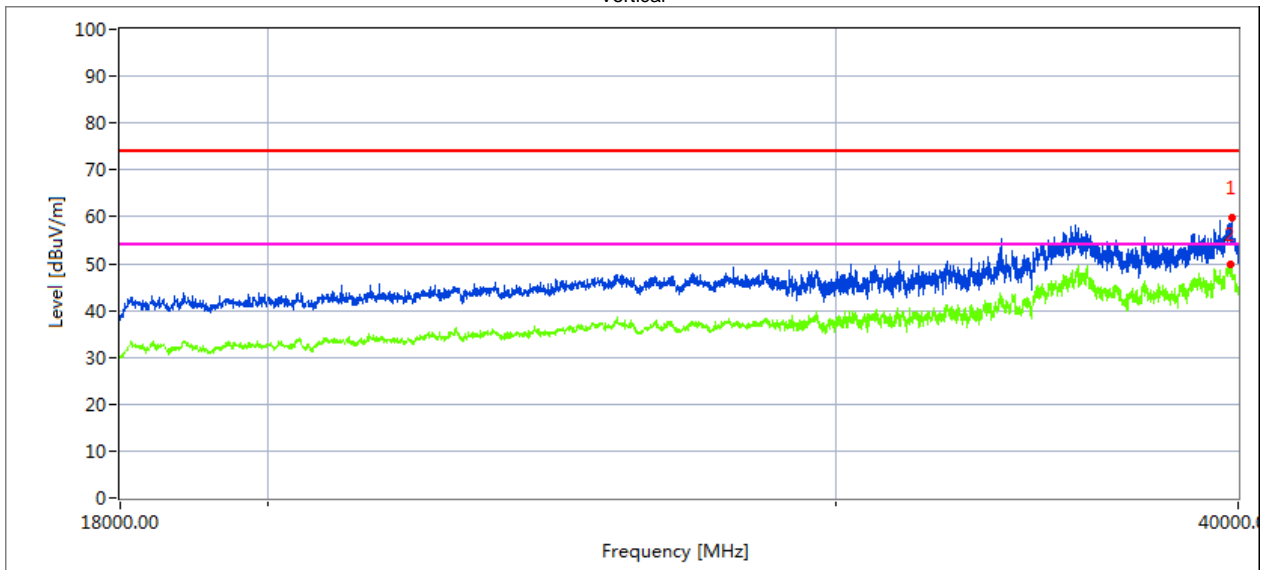

Measurement Result:

Frequency MHz	Pre-scan Level MaxPeak dBuV/m	Final Test Level MaxPeak dBuV/m	Limit MaxPeak dBuV/m	Margin dB
39803.504	59.8	49.5	74.0	24.5
39795.638	49.9	45.6	54.0	8.4

High Channel (5240 MHz)-Above 1G

Horizontal

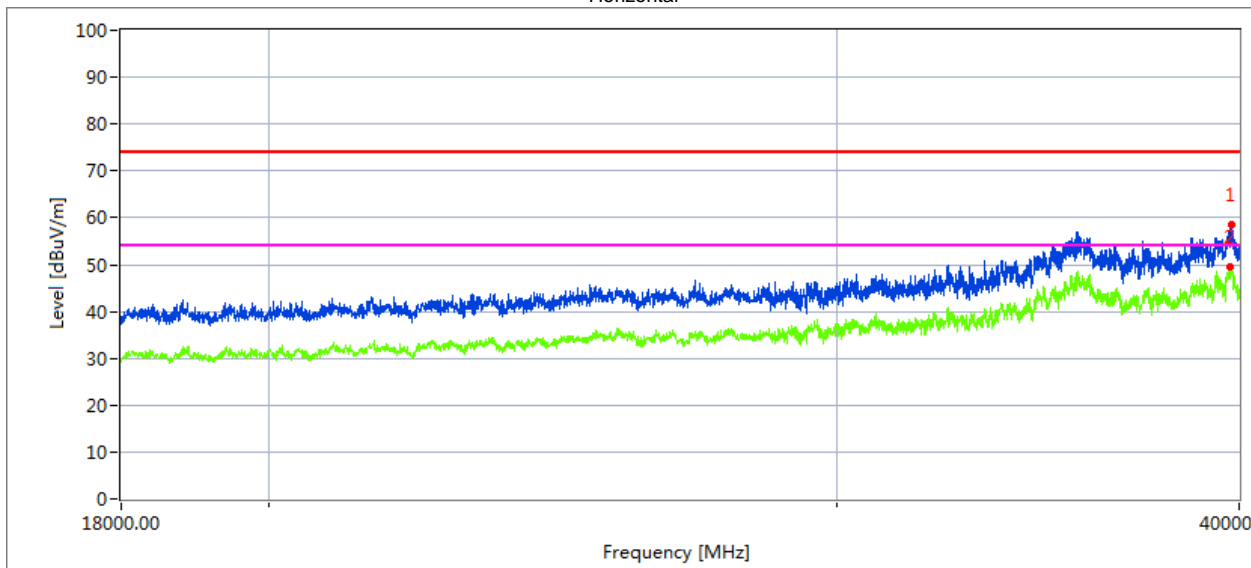

Measurement Result:

Frequency MHz	Pre-scan Level MaxPeak dBuV/m	Final Test Level MaxPeak dBuV/m	Limit MaxPeak dBuV/m	Margin dB
39792.504	58.5	39.1	74.0	34.9
39755.064	45.7	44.3	54.0	9.7

Vertical

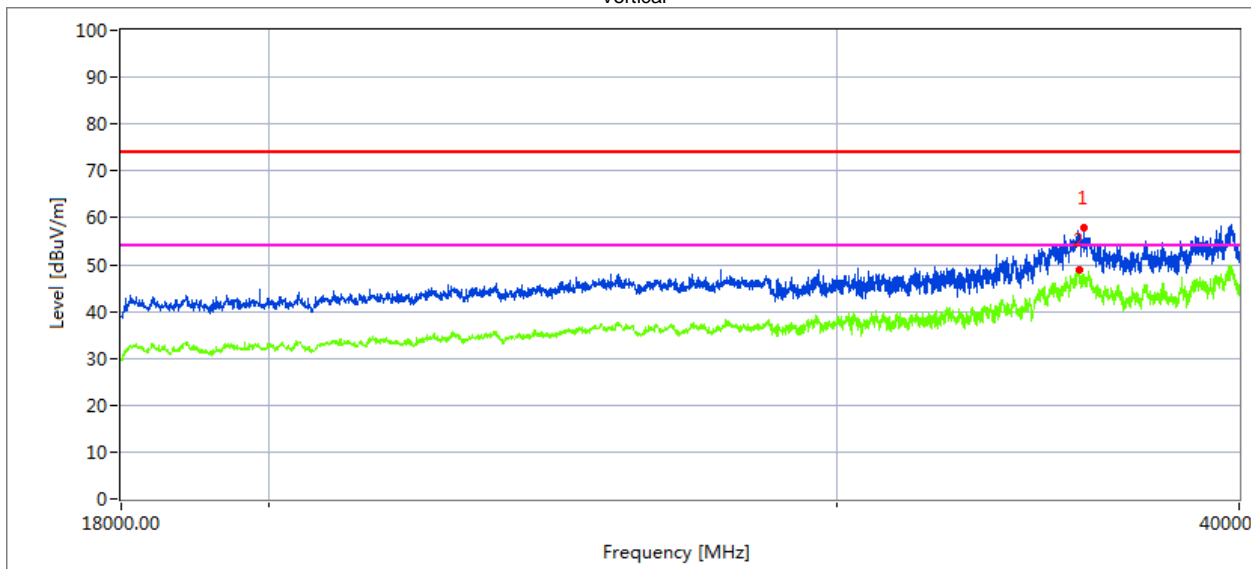

Measurement Result:

Frequency MHz	Pre-scan Level MaxPeak dBuV/m	Final Test Level MaxPeak dBuV/m	Limit MaxPeak dBuV/m	Margin dB
35794.516	57.9	56.1	74.0	17.9
35696.410	45.9	42.4	54.0	11.6

Low Channel (5260 MHz)-Above 1G

Horizontal

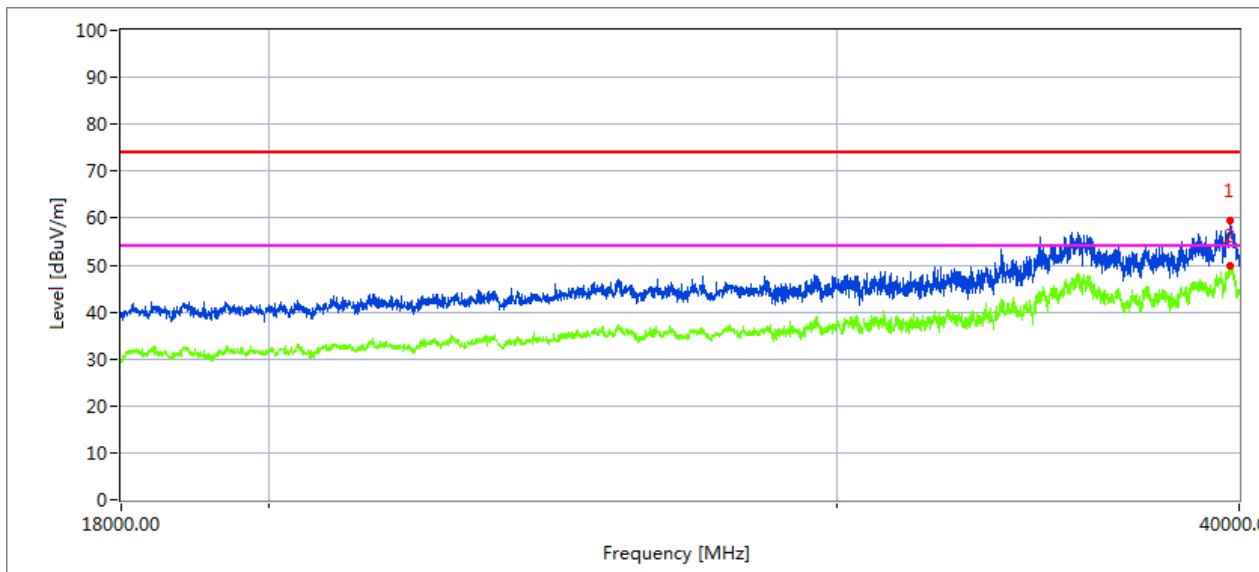

Measurement Result:

Frequency MHz	Pre-scan Level MaxPeak dBuV/m	Final Test Level MaxPeak dBuV/m	Limit MaxPeak dBuV/m	Margin dB
35628.504	59.5	56.2	74.0	17.8
35636.128	49.7	47.1	54.0	6.9

Vertical

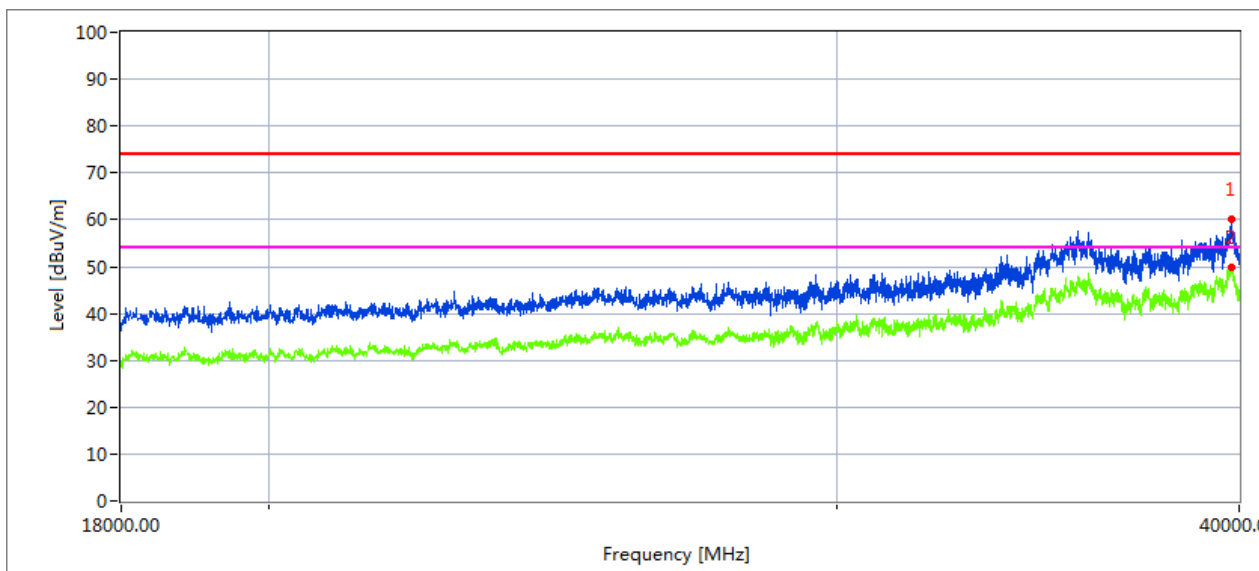

Measurement Result:

Frequency MHz	Pre-scan Level MaxPeak dBuV/m	Final Test Level MaxPeak dBuV/m	Limit MaxPeak dBuV/m	Margin dB
35628.504	60.1	59.2	74.0	14.8
35636.128	49.7	44.1	54.0	9.9

High Channel (5320 MHz)-Above 1G

Horizontal

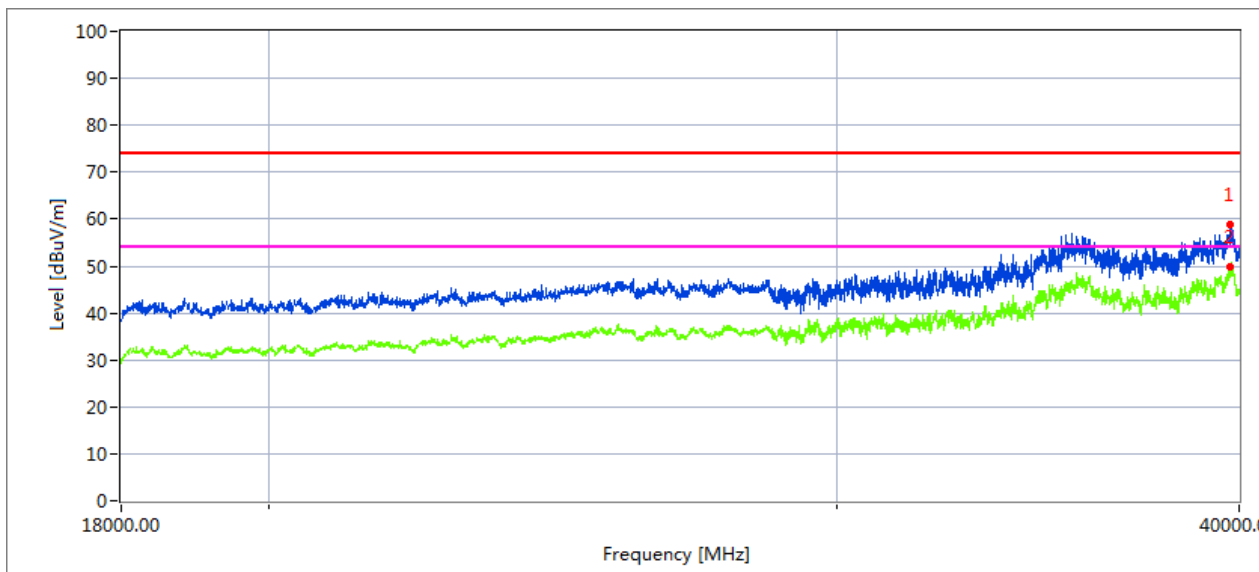

Measurement Result:

Frequency MHz	Pre-scan Level MaxPeak dBuV/m	Final Test Level MaxPeak dBuV/m	Limit MaxPeak dBuV/m	Margin dB
35628.504	58.8	58.5	74.0	15.5
35636.128	50.0	49.2	54.0	4.8

Vertical

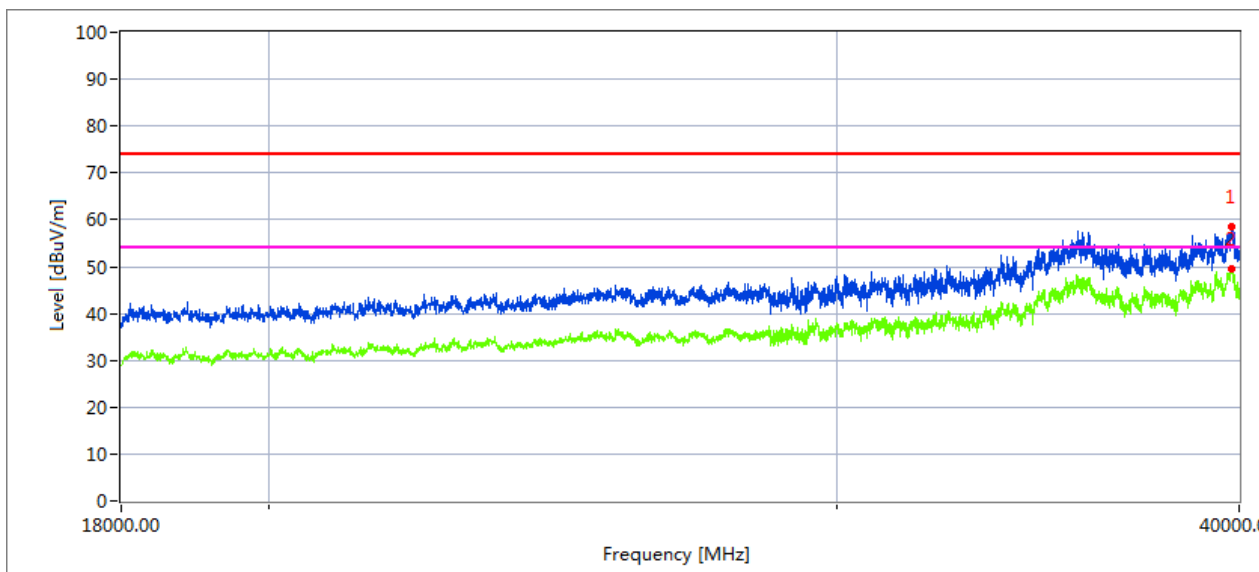

Measurement Result:

Frequency MHz	Pre-scan Level MaxPeak dBuV/m	Final Test Level MaxPeak dBuV/m	Limit MaxPeak dBuV/m	Margin dB
35628.504	58.4	55.9	74.0	18.1
35636.128	49.7	41.6	54.0	12.4

Low Channel (5500 MHz)-Above 1G
Horizontal

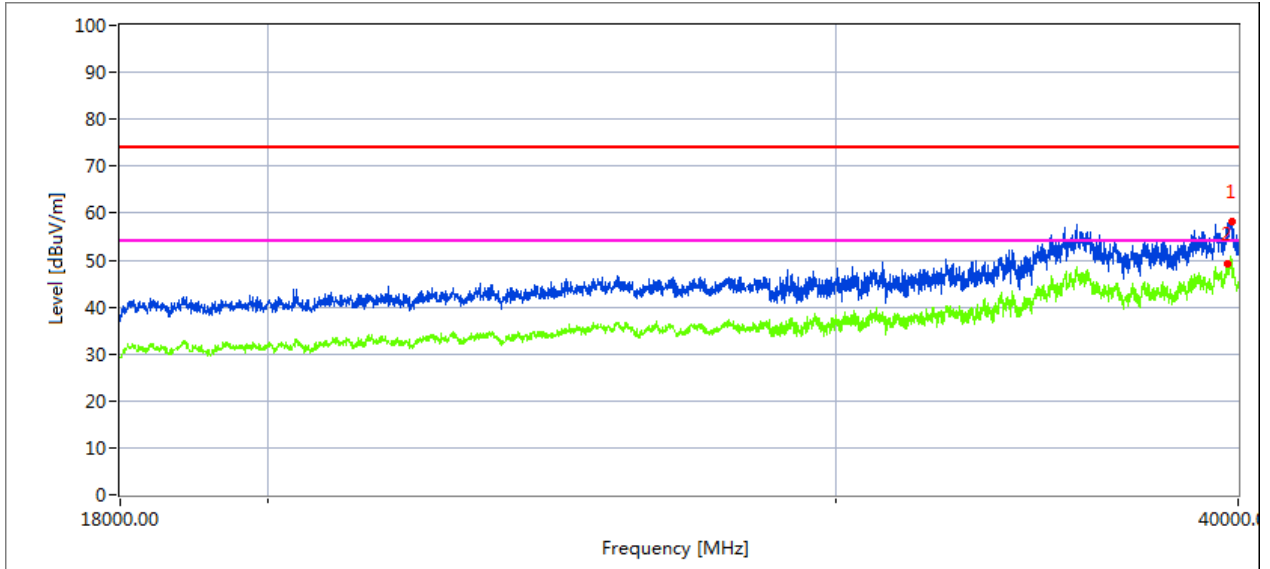

Measurement Result:

Frequency MHz	Pre-scan Level MaxPeak dBuV/m	Final Test Level MaxPeak dBuV/m	Limit MaxPeak dBuV/m	Margin dB
35628.504	58.0	47.6	74.0	26.4
35636.128	49.0	44.6	54.0	9.4

Vertical

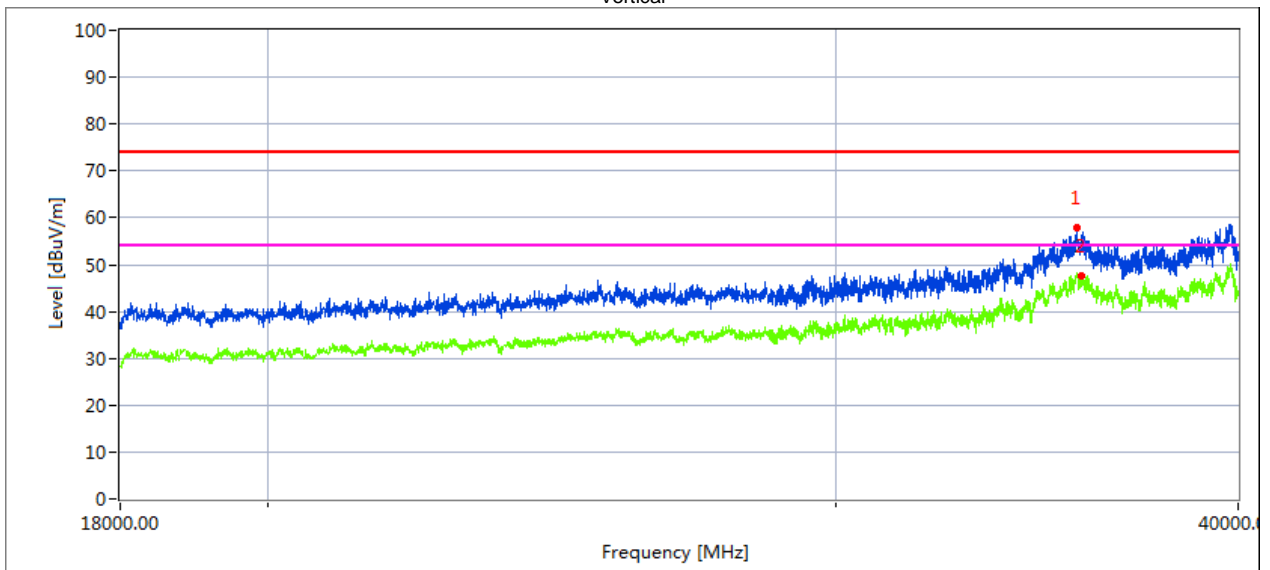

Measurement Result:

Frequency MHz	Pre-scan Level MaxPeak dBuV/m	Final Test Level MaxPeak dBuV/m	Limit MaxPeak dBuV/m	Margin dB
35628.504	57.8	50.9	74.0	23.1
35636.128	47.6	40.3	54.0	13.7

High Channel (5700 MHz)-Above 1G

Horizontal

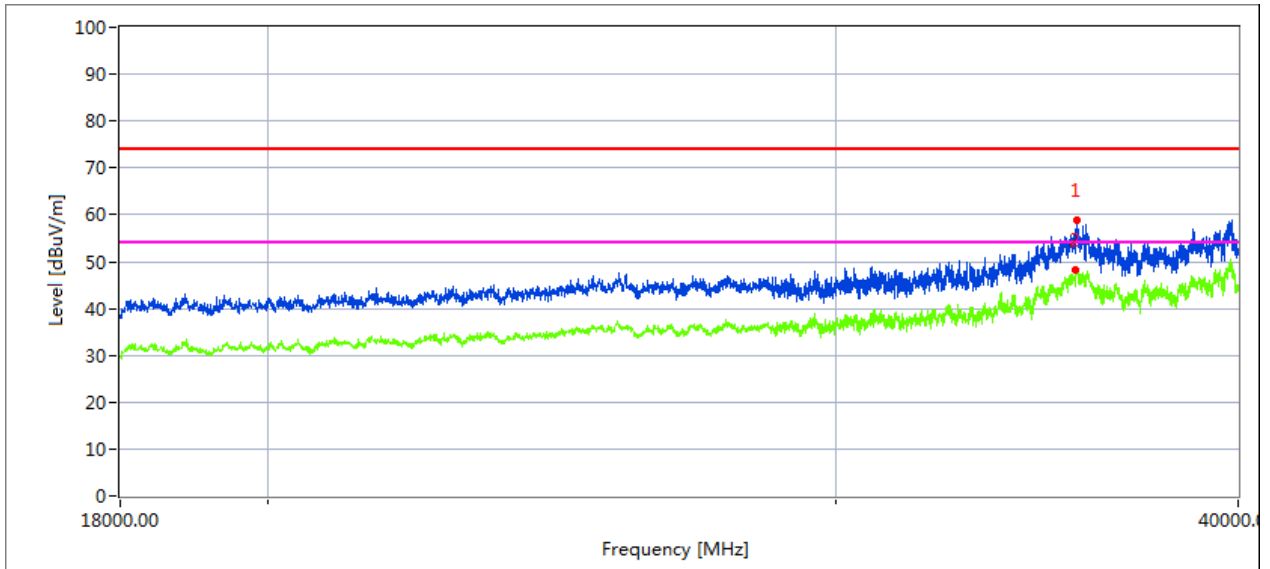

Measurement Result:

Frequency MHz	Pre-scan Level MaxPeak dBuV/m	Final Test Level MaxPeak dBuV/m	Limit MaxPeak dBuV/m	Margin dB
35628.504	58.8	37.2	74.0	36.8
35636.128	48.4	43.9	54.0	10.1

Vertical

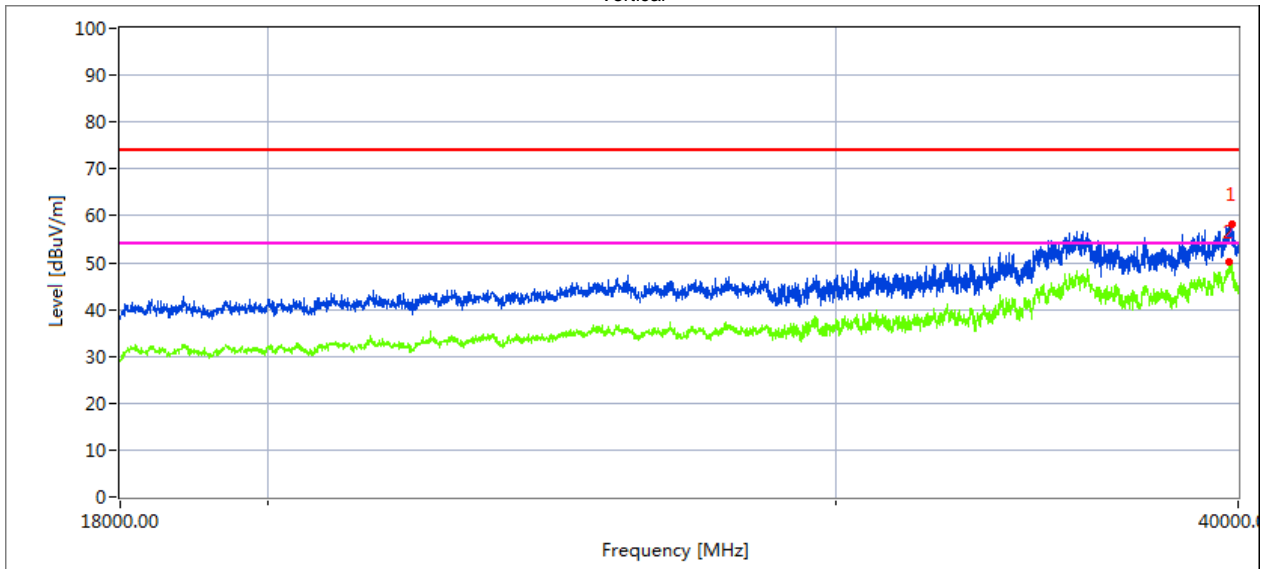

Measurement Result:

Frequency MHz	Pre-scan Level MaxPeak dBuV/m	Final Test Level MaxPeak dBuV/m	Limit MaxPeak dBuV/m	Margin dB
35628.514	58.3	47.6	74.0	26.4
35636.118	50.1	45.4	54.0	8.6

Low Channel (5745 MHz)-Above 1G

Horizontal

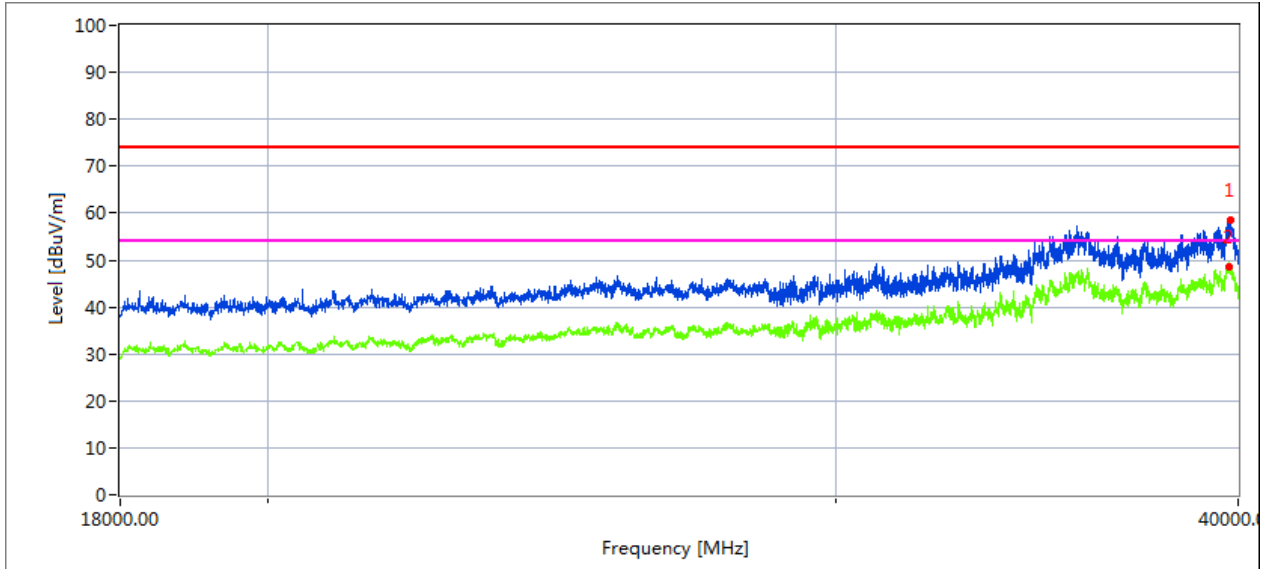

Measurement Result:

Frequency MHz	Pre-scan Level MaxPeak dBuV/m	Final Test Level MaxPeak dBuV/m	Limit MaxPeak dBuV/m	Margin dB
39787.004	58.5	44.4	74.0	29.6
39732.004	48.5	45.2	54.0	8.8

Vertical

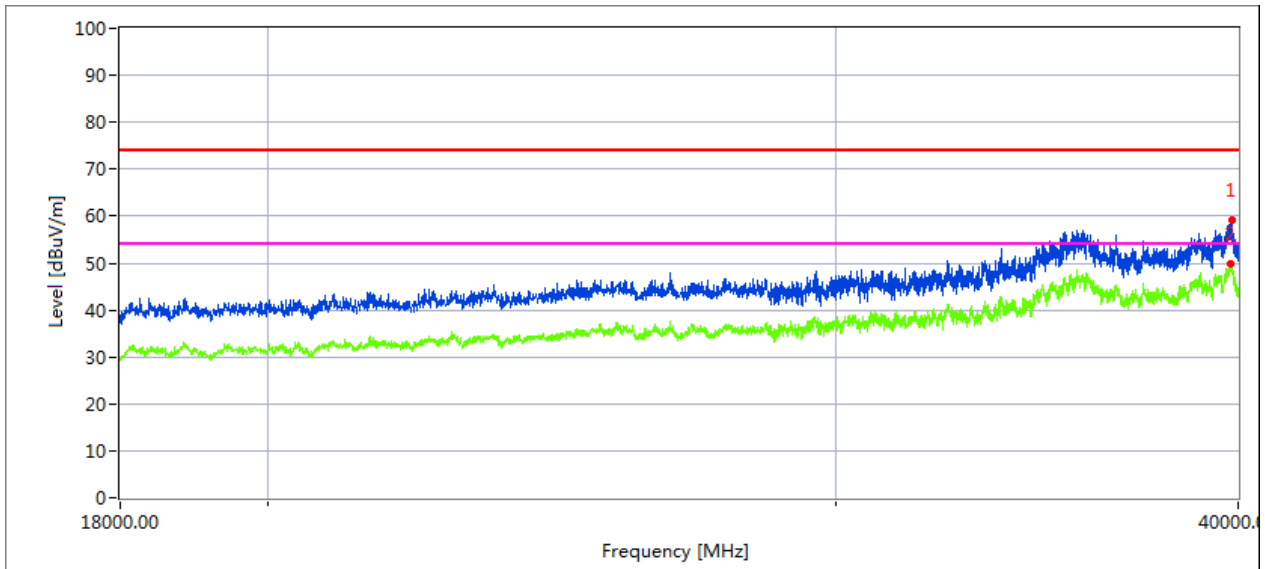

Measurement Result:

Frequency MHz	Pre-scan Level MaxPeak dBuV/m	Final Test Level MaxPeak dBuV/m	Limit MaxPeak dBuV/m	Margin dB
39809.004	59.2	45.5	74.0	28.5
39772.408	45.9	42.7	54.0	11.3

High Channel (5825 MHz)-Above 1G

Horizontal

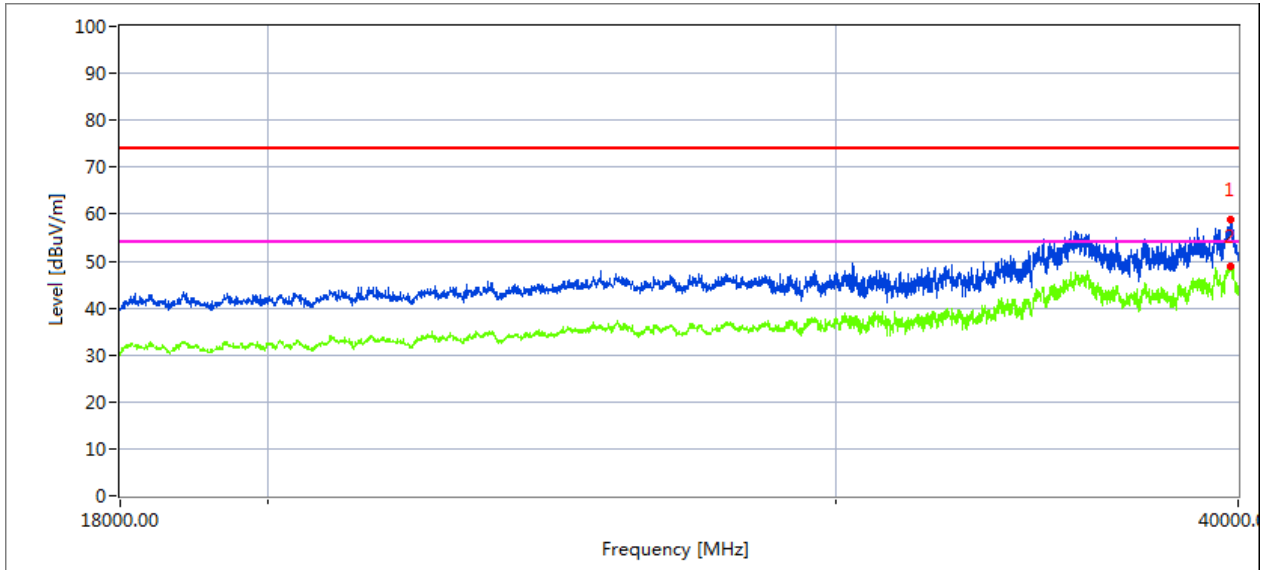

Measurement Result:

Frequency MHz	Pre-scan Level MaxPeak dBuV/m	Final Test Level MaxPeak dBuV/m	Limit MaxPeak dBuV/m	Margin dB
39774.444	58.8	56.6	74.0	17.4
39787.006	46.8	41.1	54.0	12.9

Vertical

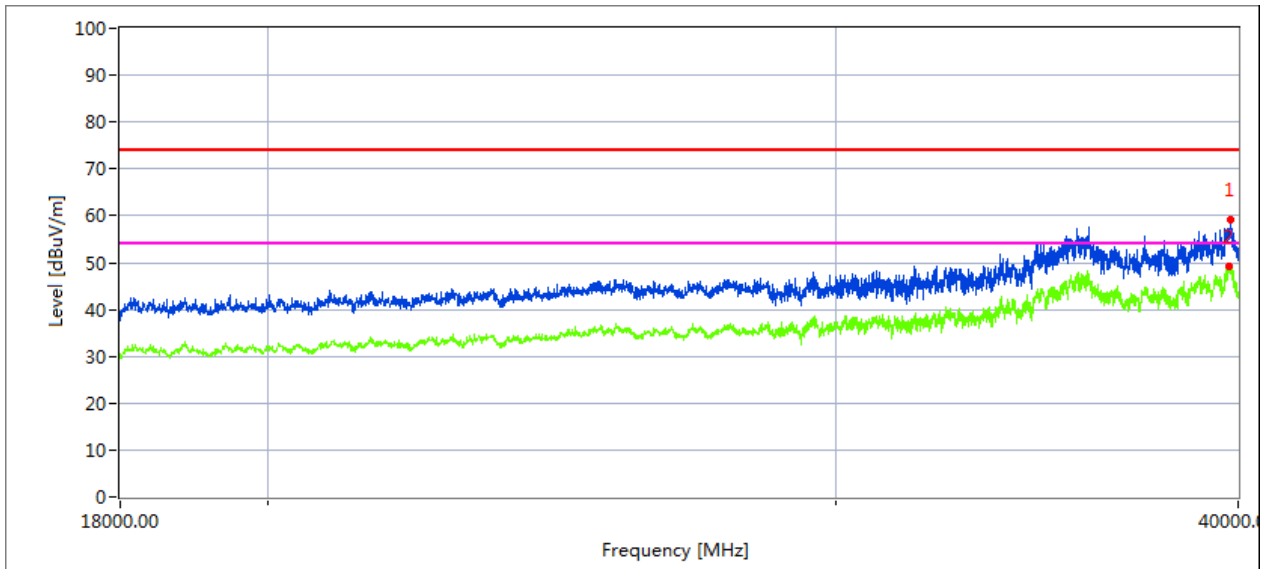

Measurement Result:

Frequency MHz	Pre-scan Level MaxPeak dBuV/m	Final Test Level MaxPeak dBuV/m	Limit MaxPeak dBuV/m	Margin dB
39798.004	59.0	41.9	74.0	32.1
39754.004	49.1	43.0	54.0	11.0

4. POWER SPECTRAL DENSITY TEST

4.1 APPLIED PROCEDURES / LIMIT

According to FCC §15.407(a)

For the band 5.15-5.25 GHz,

(i) For an outdoor access point operating in the band 5.15-5.25 GHz, the maximum power spectral density shall not exceed 17 dBm in any 1 megahertz band. If transmitting antennas of directional gain greater than 6 dBi are used, both the maximum conducted output power and the maximum power spectral density shall be reduced by the amount in dB that the directional gain of the antenna exceeds 6 dBi. The maximum e.i.r.p. at any elevation angle above 30 degrees as measured from the horizon must not exceed 125 mW (21 dBm).

(ii) For an indoor access point operating in the band 5.15-5.25 GHz, the maximum power spectral density shall not exceed 17 dBm in any 1 megahertz band. If transmitting antennas of directional gain greater than 6 dBi are used, both the maximum conducted output power and the maximum power spectral density shall be reduced by the amount in dB that the directional gain of the antenna exceeds 6 dBi.

(iii) For fixed point-to-point access points operating in the band 5.15-5.25 GHz, the maximum power spectral density shall not exceed 17 dBm in any 1 megahertz band. Fixed point-to-point U-NII devices may employ antennas with directional gain up to 23 dBi without any corresponding reduction in the maximum conducted output power or maximum power spectral density. For fixed point-to-point transmitters that employ a directional antenna gain greater than 23 dBi, a 1 dB reduction in maximum conducted output power and maximum power spectral density is required for each 1 dB of antenna gain in excess of 23 dBi. Fixed, point-to-point operations exclude the use of point-to-multipoint systems, omnidirectional applications, and multiple collocated transmitters transmitting the same information. The operator of the U-NII device, or if the equipment is professionally installed, the installer, is responsible for ensuring that systems employing high gain directional antennas are used exclusively for fixed, point-to-point operations.

(iv) For client devices in the 5.15-5.25 GHz band, the maximum power spectral density shall not exceed 11 dBm in any 1 megahertz band. If transmitting antennas of directional gain greater than 6 dBi are used, both the maximum conducted output power and the maximum power spectral density shall be reduced by the amount in dB that the directional gain of the antenna exceeds 6 dBi.

For the 5.25-5.35 GHz and 5.47-5.725 GHz bands, the maximum conducted output power over the frequency bands of operation shall not exceed the lesser of 250 mW or $11 \text{ dBm} + 10 \log B$, where B is the 26 dB emission bandwidth in megahertz. In addition, the maximum power spectral density shall not exceed 11 dBm in any 1 megahertz band. If transmitting antennas of directional gain greater than 6 dBi are used, both the maximum conducted output power and the maximum power spectral density shall be reduced by the amount in dB that the directional gain of the antenna exceeds 6 dBi.

For the band 5.725-5.85 GHz

(3) For the band 5.725-5.85 GHz, the maximum power spectral density shall not exceed 30 dBm in any 500-kHz band. If transmitting antennas of directional gain greater than 6 dBi are used, both the maximum conducted output power and the maximum power spectral density shall be reduced by the amount in dB that the directional gain of the antenna exceeds 6 dBi.

,

4.2 TEST PROCEDURE

For devices operating in the bands 5.15-5.25 GHz, 5.25-5.35 GHz, and 5.47-5.725 GHz, the above procedures make use of 1 MHz RBW to satisfy directly the 1 MHz reference bandwidth specified in § 15.407(a)(5). For devices operating in the band 5.725-5.85 GHz, the rules specify a measurement bandwidth of 500 kHz. Many spectrum analyzers do not have 500 kHz RBW, thus a narrower RBW may need to be used. The rules permit the use of a RBWs less than 1 MHz, or 500 kHz, “provided that the measured power is integrated over the full reference bandwidth” to show the total power over the specified measurement bandwidth (i.e., 1 MHz, or 500 kHz). If measurements are performed using a reduced resolution bandwidth (< 1 MHz, or < 500 kHz) and integrated over 1 MHz, or 500 KHz bandwidth, the following adjustments to the procedures apply:

- a) Set $RBW \geq 1/T$, where T is defined in section II.B.I.a).
- b) Set $VBW \geq 3 RBW$.
- c) If measurement bandwidth of Maximum PSD is specified in 500 kHz, add $10\log(500\text{kHz}/RBW)$ to the measured result, whereas $RBW (< 500 \text{ KHz})$ is the reduced resolution bandwidth of the spectrum analyzer set during measurement.
- d) If measurement bandwidth of Maximum PSD is specified in 1 MHz, add $10\log(1\text{MHz}/RBW)$ to the measured result, whereas $RBW (< 1 \text{ MHz})$ is the reduced resolution bandwidth of spectrum analyzer set during measurement.
- e) Care must be taken to ensure that the measurements are performed during a period of continuous transmission or are corrected upward for duty cycle.

Note: As a practical matter, it is recommended to use reduced RBW of 100 KHz for the sections 5.c) and 5.d) above, since $RBW=100 \text{ KHz}$ is available on nearly all spectrum analyzers.

4.3 DEVIATION FROM STANDARD

No deviation.

4.4 TEST SETUP



4.5 EUT OPERATION CONDITIONS

The EUT tested system was configured as the statements of 2.1 Unless otherwise a special operating condition is specified in the follows during the testing.

4.6 TEST RESULTS

EUT :	Wireless Digital Terminal	Model Name. :	S611
Temperature :	25 °C	Relative Humidity :	56%
Pressure :	1015 hPa	Test Voltage :	DC 3.85V
Test Mode :	TX Frequency Band 1 (5150-5250MHz)		

Mode	Frequency	Measured Power Density (dBm)	Limit (dBm/MHz)	Result
802.11 a	5180 MHz	4.91	11	PASS
	5200 MHz	5.36	11	PASS
	5240 MHz	5.77	11	PASS
802.11 n20	5180 MHz	4.29	11	PASS
	5200 MHz	4.96	11	PASS
	5240 MHz	5.51	11	PASS
802.11 n40	5190 MHz	0.67	11	PASS
	5230 MHz	1.90	11	PASS
802.11 ac20	5180 MHz	4.04	11	PASS
	5200 MHz	4.78	11	PASS
	5240 MHz	5.34	11	PASS
802.11 ac40	5190 MHz	1.00	11	PASS
	5230 MHz	1.47	11	PASS
802.11 ac80	5210 MHz	-1.74	11	PASS

(802.11a) PSD plot on channel 36

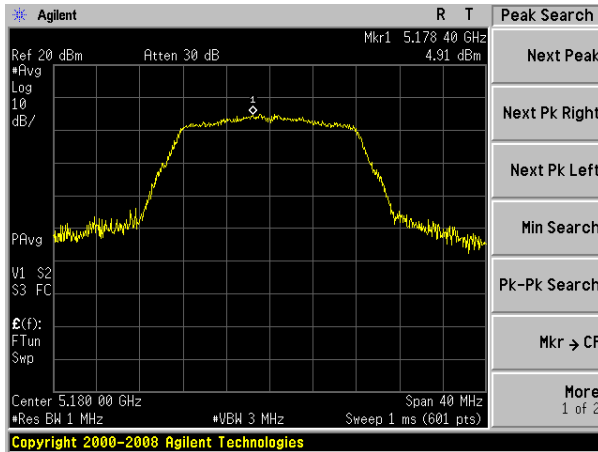

(802.11n20) PSD plot on channel 36

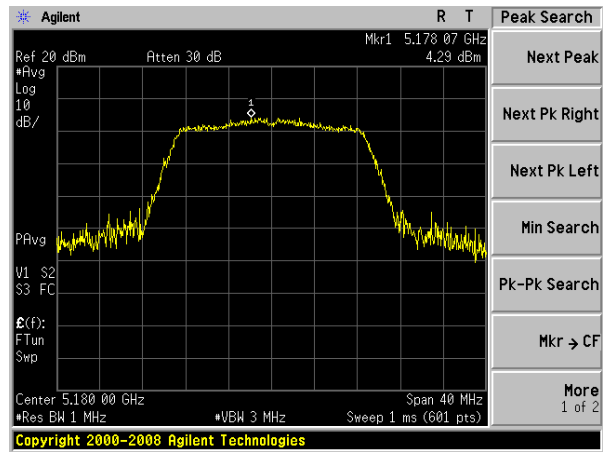

(802.11a) PSD plot on channel 40

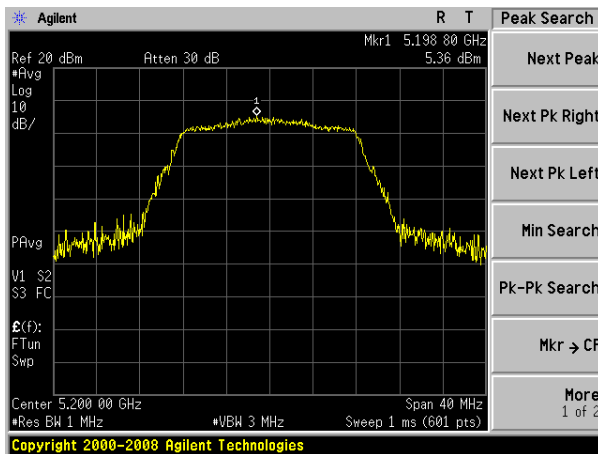

(802.11n20) PSD plot on channel 40

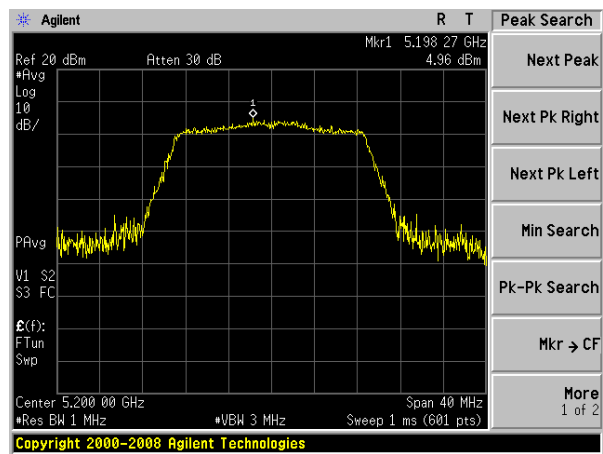

(802.11a) PSD plot on channel 48

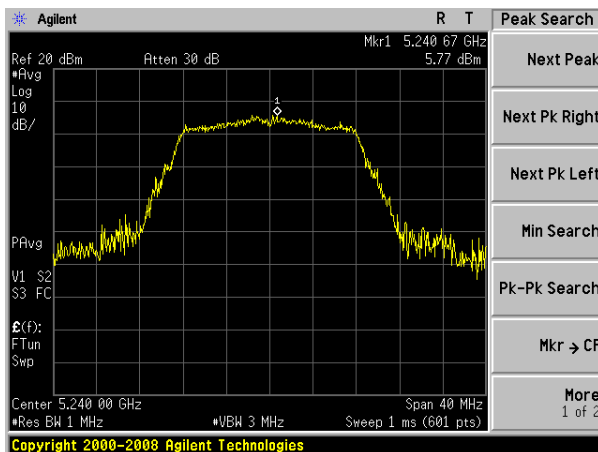

(802.11n20) PSD plot on channel 48

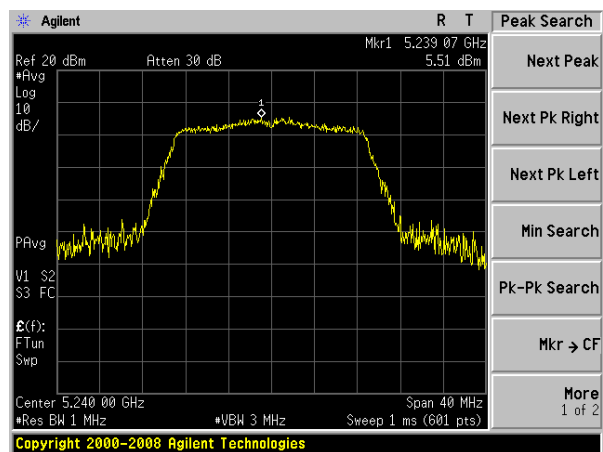

(802.11n40) PSD plot on channel 38

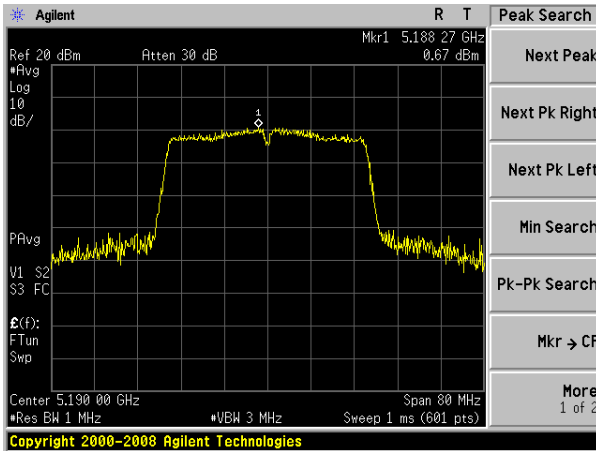

(802.11ac20) PSD plot on channel 36

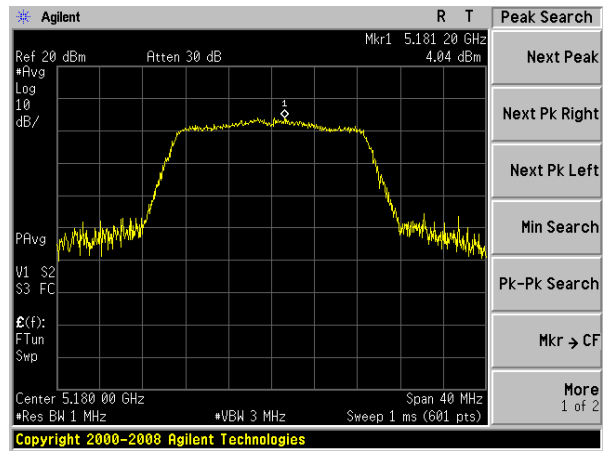

(802.11n40) PSD plot on channel 46

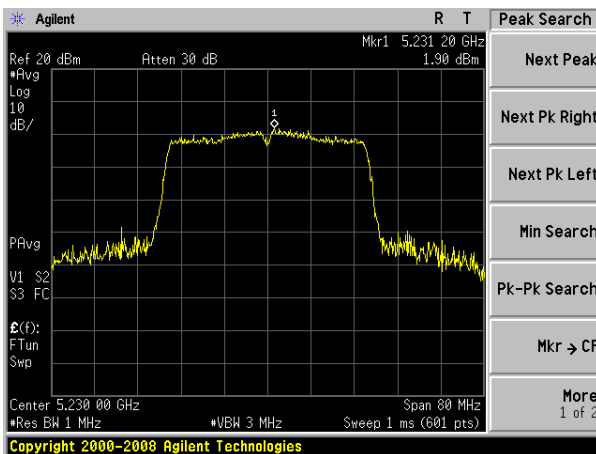

(802.11ac20) PSD plot on channel 40

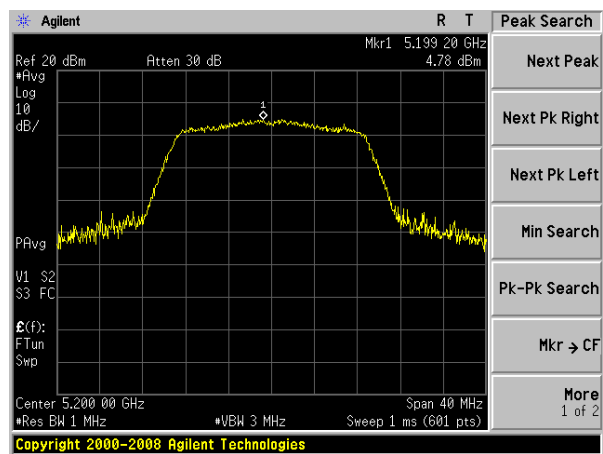

(802.11ac20) PSD plot on channel 48

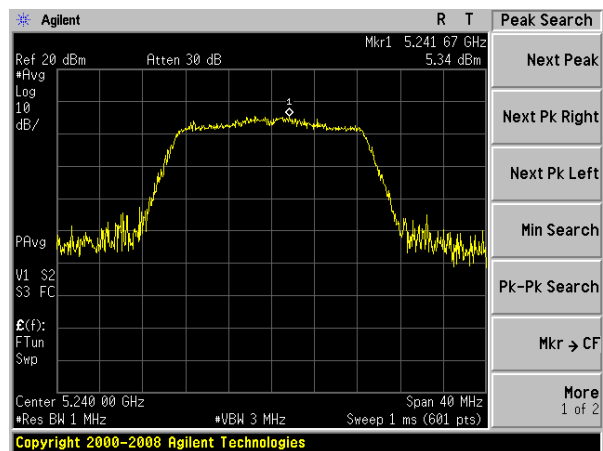

(802.11ac40) PSD plot on channel 38

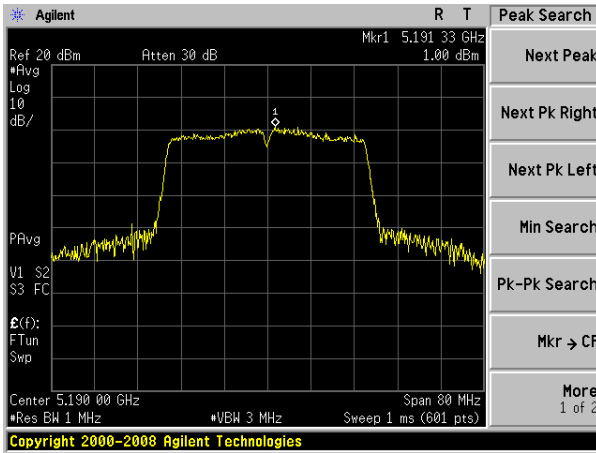

(802.11ac80) PSD plot on channel 42

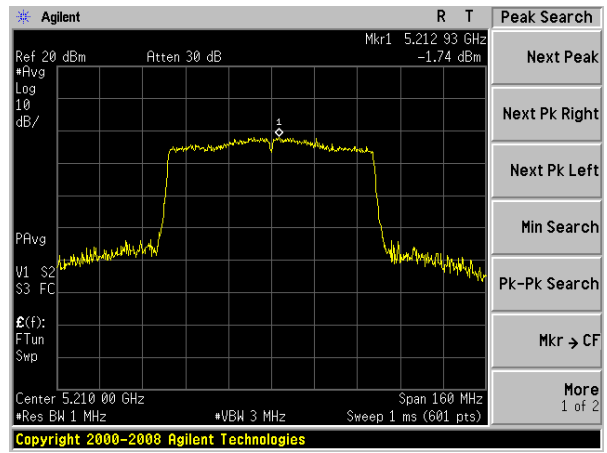

(802.11ac40) PSD plot on channel 46

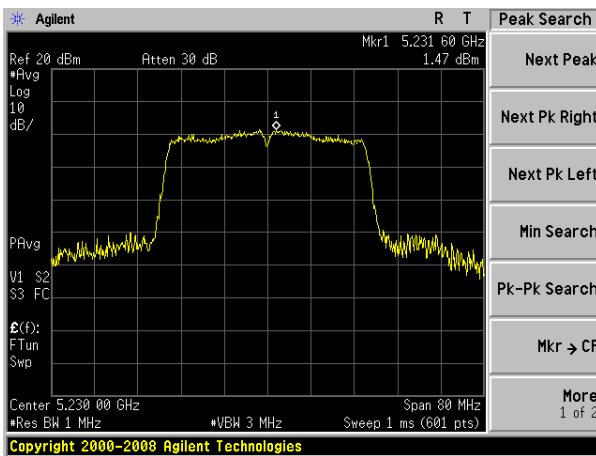

EUT :	Wireless Digital Terminal	Model Name. :	S611
Temperature :	25 °C	Relative Humidity :	56%
Pressure :	1015 hPa	Test Voltage :	DC 3.85V
Test Mode :	TX Frequency Band 2A (5250-5350MHz)		

Mode	Frequency	Measured Power Density (dBm)	Limit (dBm/MHz)	Result
802.11 a	5260 MHz	4.15	11	PASS
	5280 MHz	4.56	11	PASS
	5320 MHz	4.44	11	PASS
802.11 n20	5260 MHz	3.59	11	PASS
	5280 MHz	4.01	11	PASS
	5320 MHz	4.28	11	PASS
802.11 n40	5270 MHz	0.81	11	PASS
	5310 MHz	0.83	11	PASS
802.11 ac20	5260 MHz	3.59	11	PASS
	5280 MHz	4.66	11	PASS
	5320 MHz	4.25	11	PASS
802.11 ac40	5270 MHz	0.50	11	PASS
	5310 MHz	2.12	11	PASS
802.11 ac80	5290 MHz	-1.37	11	PASS

(802.11a) PSD plot on channel 52

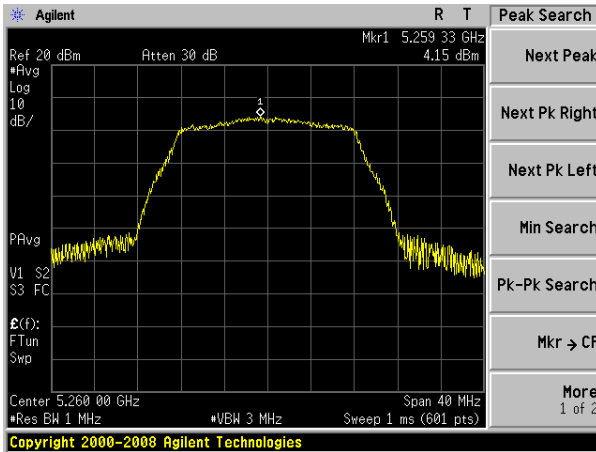

(802.11n20) PSD plot on channel 52

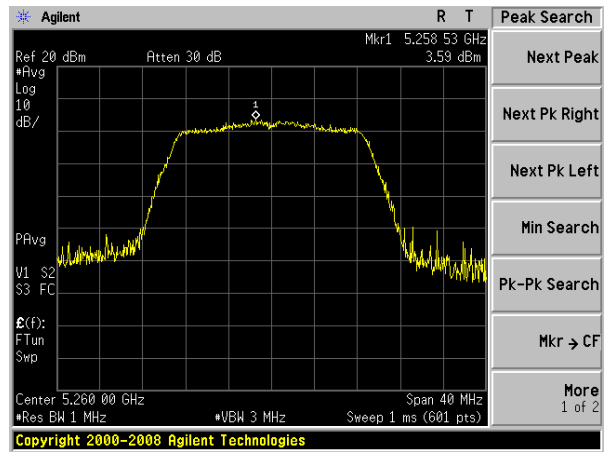

(802.11a) PSD plot on channel 56

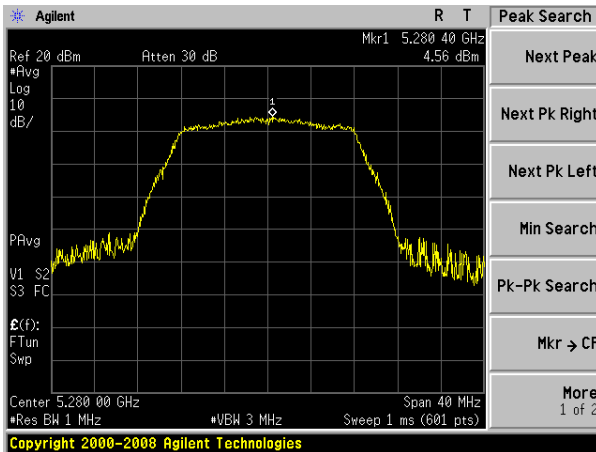

(802.11n20) PSD plot on channel 56

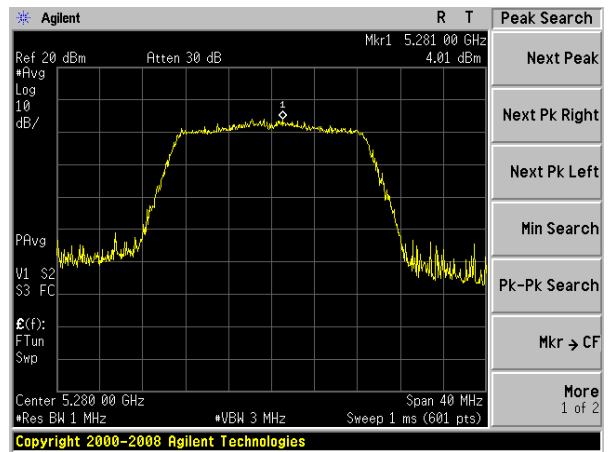

(802.11a) PSD plot on channel 64

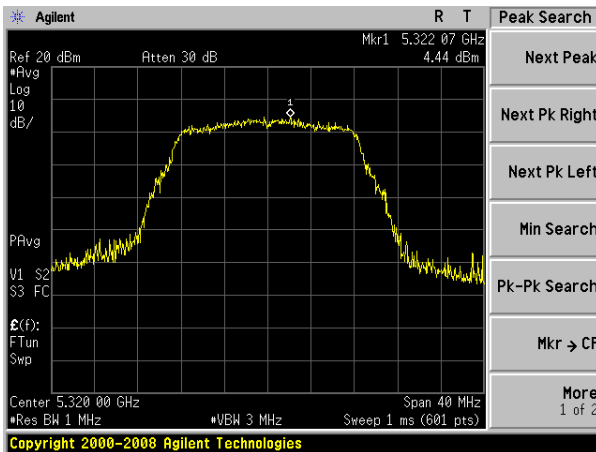

(802.11n20) PSD plot on channel 64

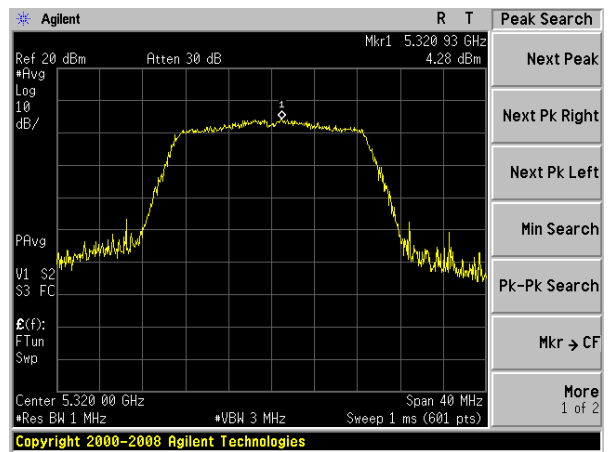

(802.11n40) PSD plot on channel 54

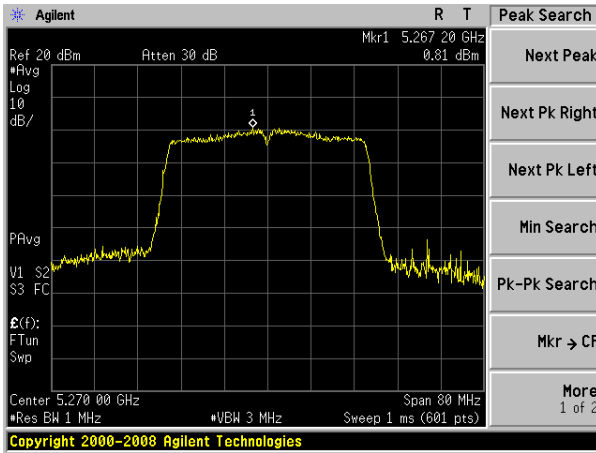

(802.11ac20) PSD plot on channel 52

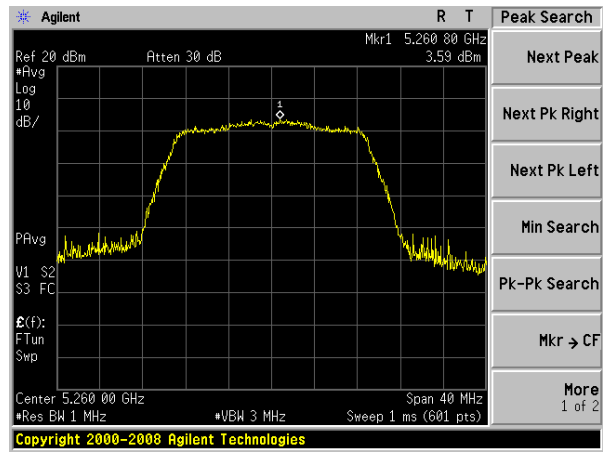

(802.11n40) PSD plot on channel 62

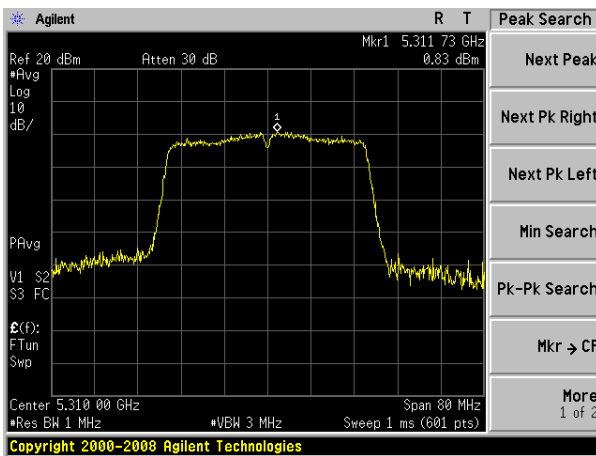

(802.11ac20) PSD plot on channel 56

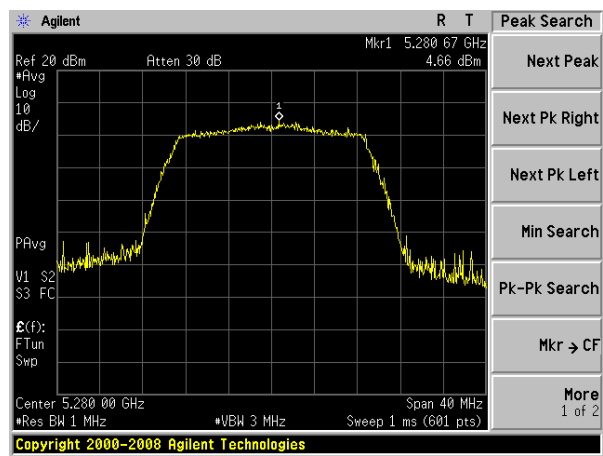

(802.11ac20) PSD plot on channel 64

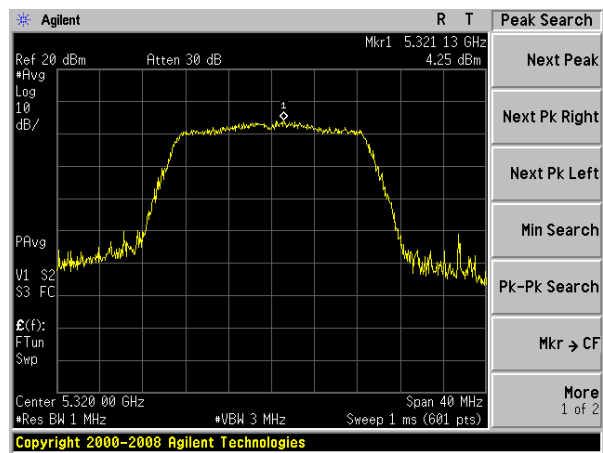

(802.11ac40) PSD plot on channel 54

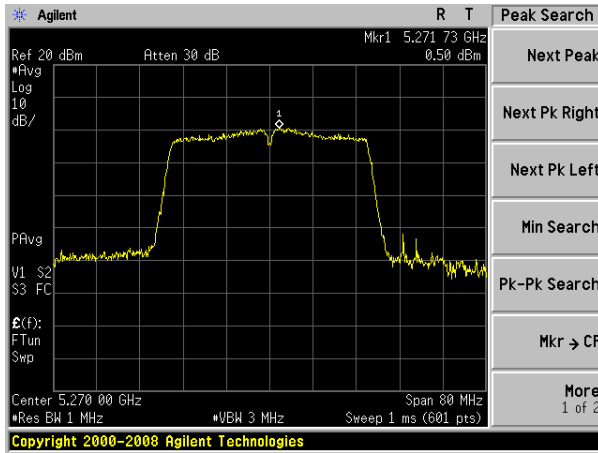

(802.11ac80) PSD plot on channel 58

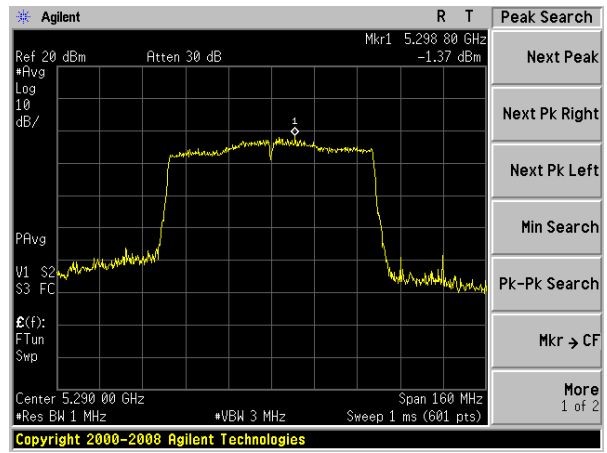

(802.11ac40) PSD plot on channel 62

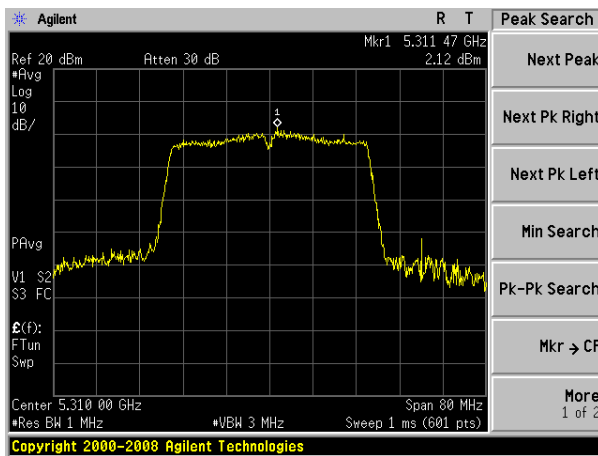

EUT :	Wireless Digital Terminal	Model Name. :	S611
Temperature :	25 °C	Relative Humidity :	56%
Pressure :	1015 hPa	Test Voltage :	DC 3.85V
Test Mode :	TX Frequency Band 2C (5470-5725MHz)		

Mode	Frequency	Measured Power Density (dBm)	Limit (dBm/MHz)	Result
802.11 a	5500 MHz	5.20	11	PASS
	5600 MHz	5.15	11	PASS
	5700 MHz	5.49	11	PASS
802.11 n20	5500 MHz	5.40	11	PASS
	5600 MHz	4.95	11	PASS
	5700 MHz	4.73	11	PASS
802.11 n40	5510 MHz	1.78	11	PASS
	5590 MHz	1.68	11	PASS
	5670 MHz	1.71	11	PASS
802.11 ac20	5500 MHz	4.90	11	PASS
	5600 MHz	4.98	11	PASS
	5700 MHz	5.44	11	PASS
802.11 ac40	5510 MHz	1.94	11	PASS
	5590 MHz	1.69	11	PASS
	5670 MHz	2.79	11	PASS
802.11 ac80	5530 MHz	-1.61	11	PASS
802.11ac80	5610 MHz	-1.98	11	PASS

(802.11a) PSD plot on channel 100

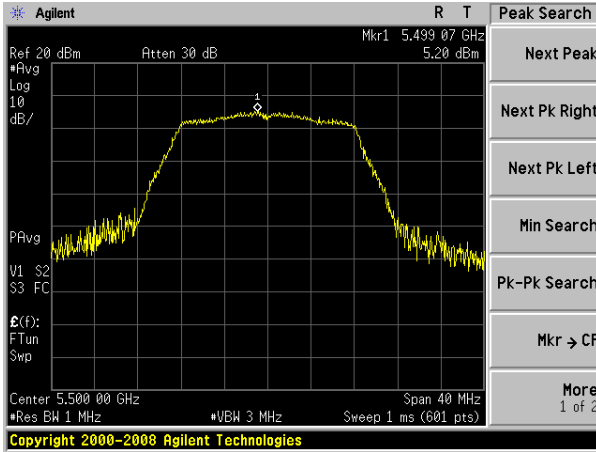

(802.11n20) PSD plot on channel 100

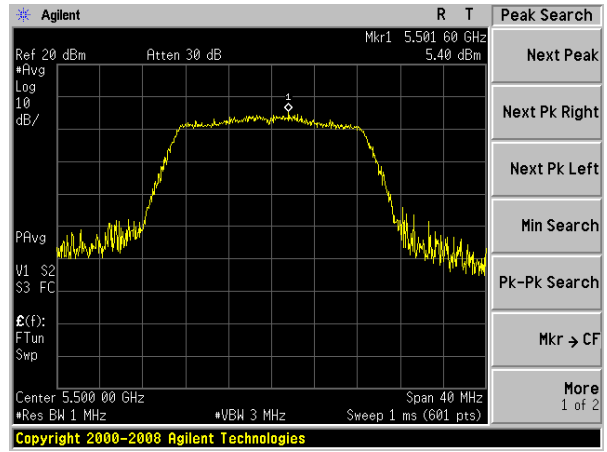

(802.11a) PSD plot on channel 120

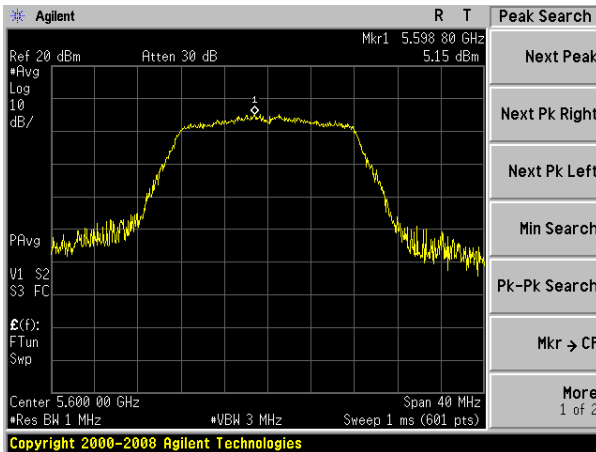

(802.11n20) PSD plot on channel 120

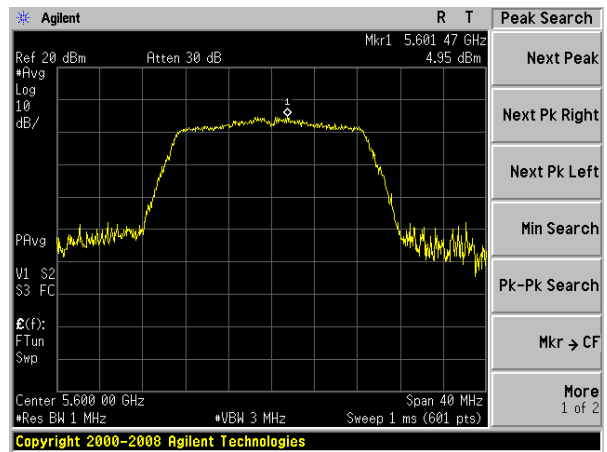

(802.11a) PSD plot on channel 140

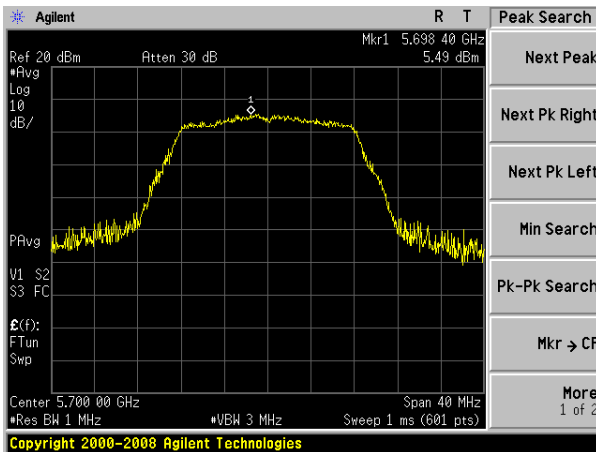

(802.11n20) PSD plot on channel 140

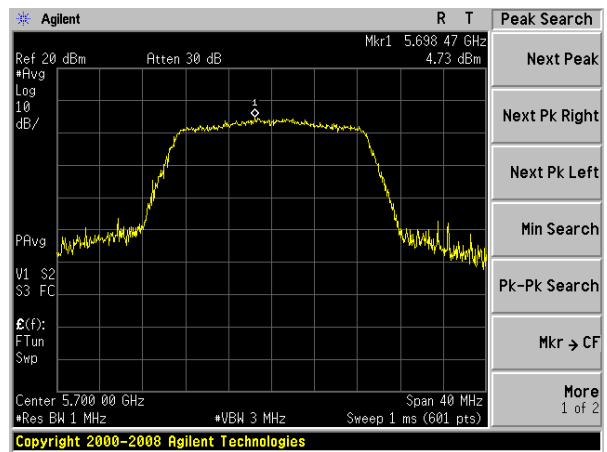

(802.11n40) PSD plot on channel 102

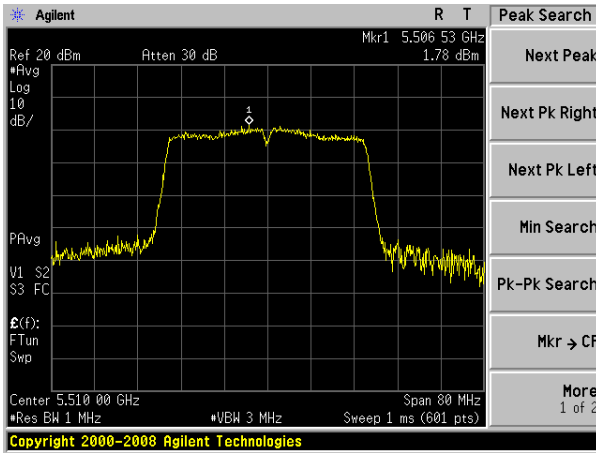

(802.11ac20) PSD plot on channel 100

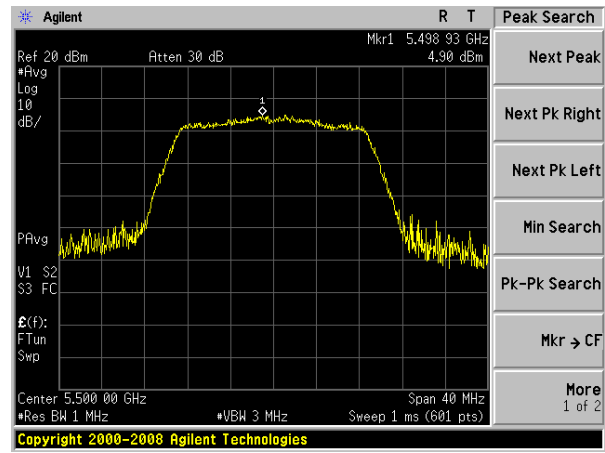

(802.11n40) PSD plot on channel 118

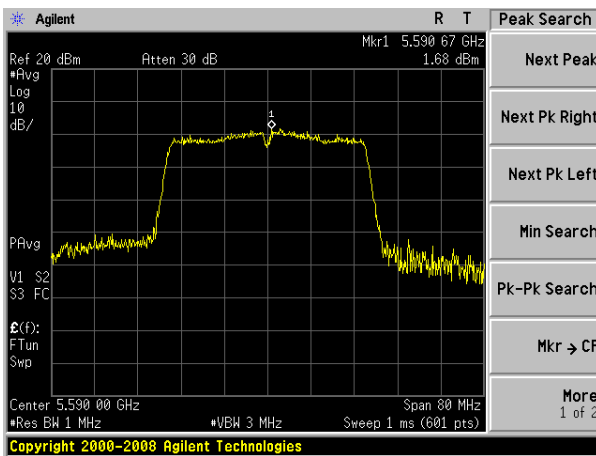

(802.11ac20) PSD plot on channel 120

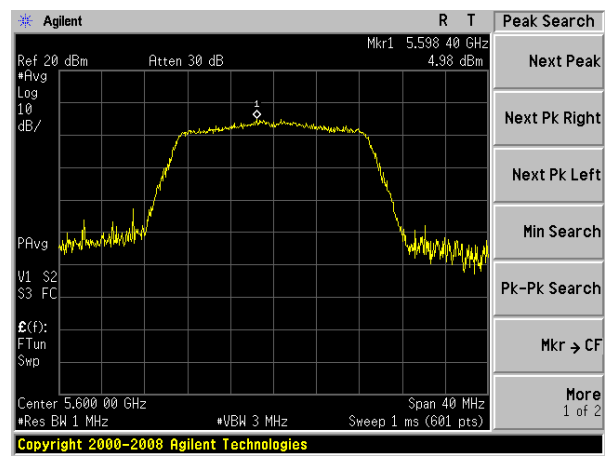

(802.11n40) PSD plot on channel 134

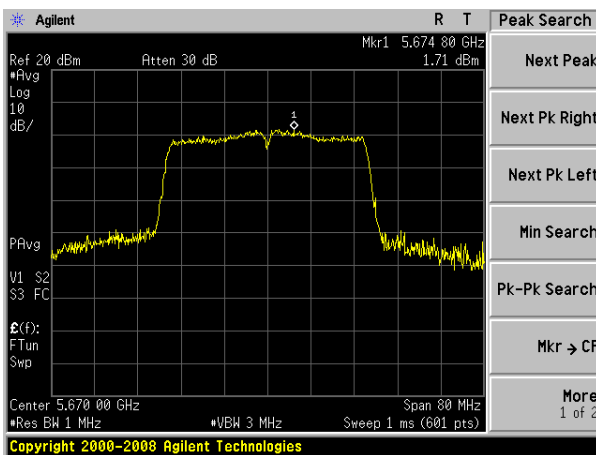

(802.11ac20) PSD plot on channel 140

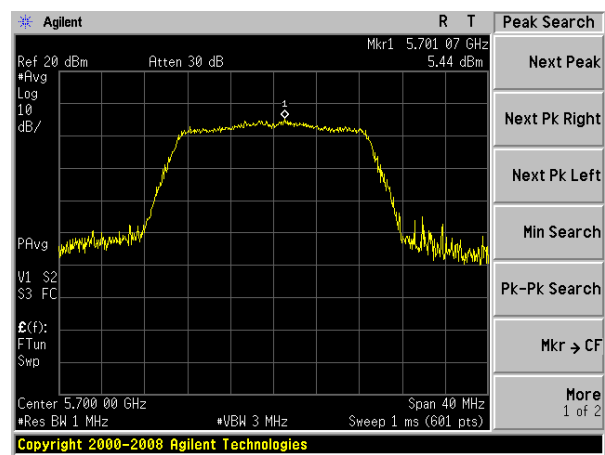

(802.11ac40) PSD plot on channel 102

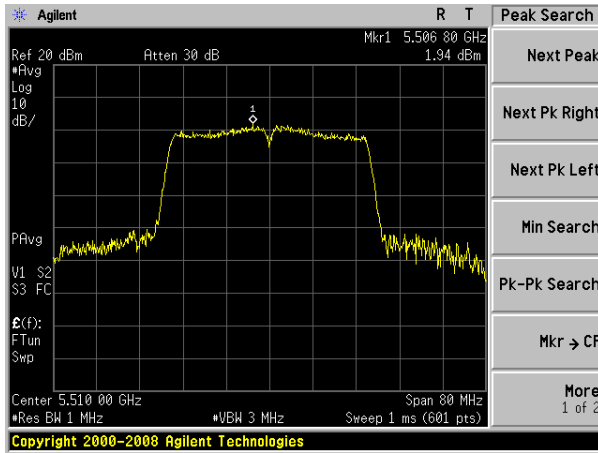

(802.11ac80) PSD plot on channel 106

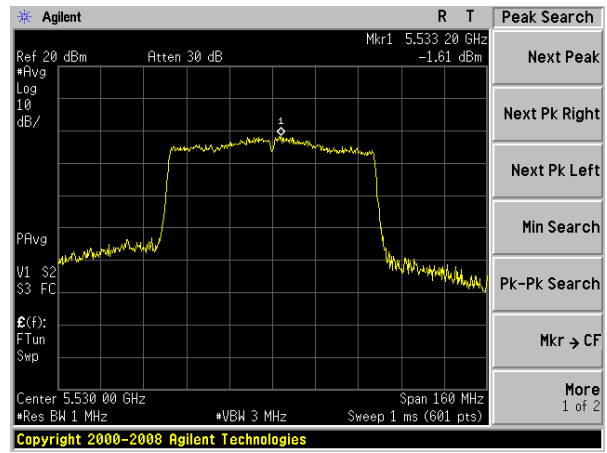

(802.11ac40) PSD plot on channel 118

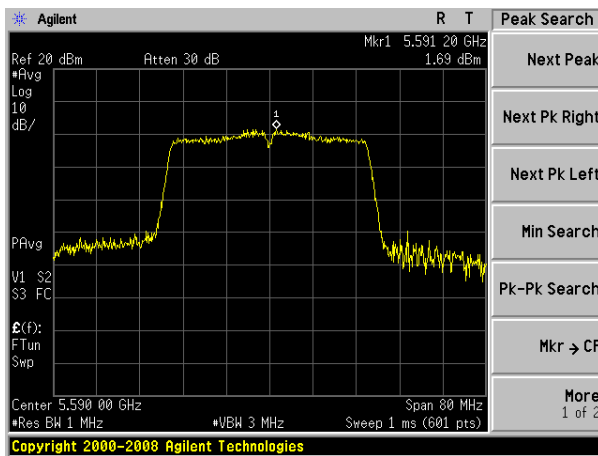

(802.11ac80) PSD plot on channel 122

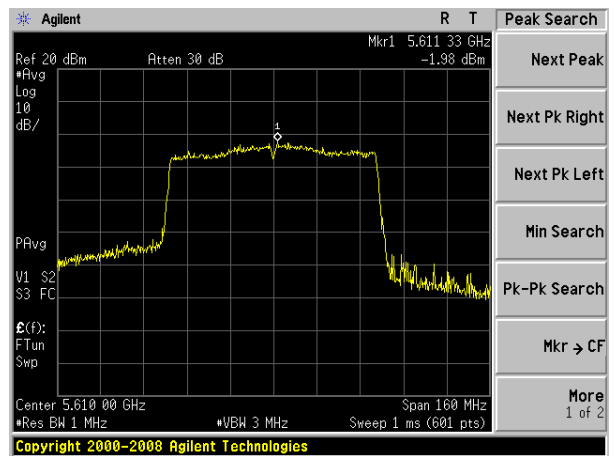

(802.11ac40) PSD plot on channel 134

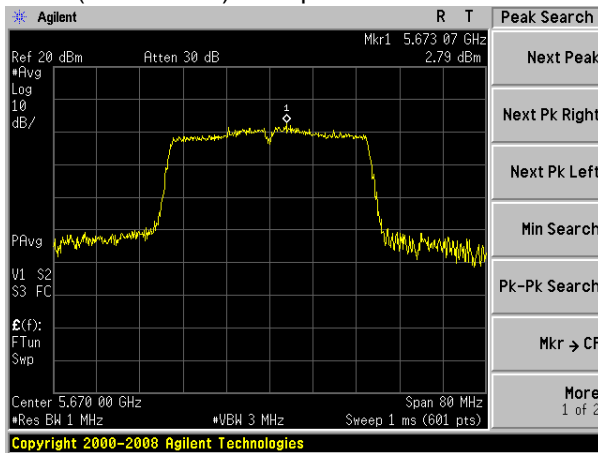

EUT :	Wireless Digital Terminal	Model Name. :	S611
Temperature :	25 °C	Relative Humidity :	56%
Pressure :	1015 hPa	Test Voltage :	DC 3.85V
Test Mode :	TX Frequency Band 3 (5745-5825MHz)		

Mode	Frequency	Measured Power Density (dBm)	Calculate power density (dBm)(Note 1)	Limit (dBm)	Result
802.11 a	5745 MHz	3.50	3.414	30	PASS
	5785 MHz	4.29	4.204	30	PASS
	5825 MHz	4.21	4.124	30	PASS
802.11 n20	5745 MHz	3.49	3.404	30	PASS
	5785 MHz	3.11	3.024	30	PASS
	5825 MHz	3.63	3.544	30	PASS
802.11 n40	5755 MHz	0.20	0.114	30	PASS
	5795 MHz	1.09	1.004	30	PASS
802.11 ac20	5745 MHz	3.99	3.904	30	PASS
	5785 MHz	3.69	3.604	30	PASS
	5825 MHz	3.66	3.574	30	PASS
802.11 ac40	5755 MHz	0.13	0.044	30	PASS
	5795 MHz	-0.32	-0.406	30	PASS
802.11 ac80	5775 MHz	-4.92	-5.006	30	PASS

Note:

(1) Calculate power density= Measured Power Density+10log(500kHz/RBW)= Measured Power Density+(-0.086)
RBW=0.51MHz

(802.11a) PSD plot on channel 149

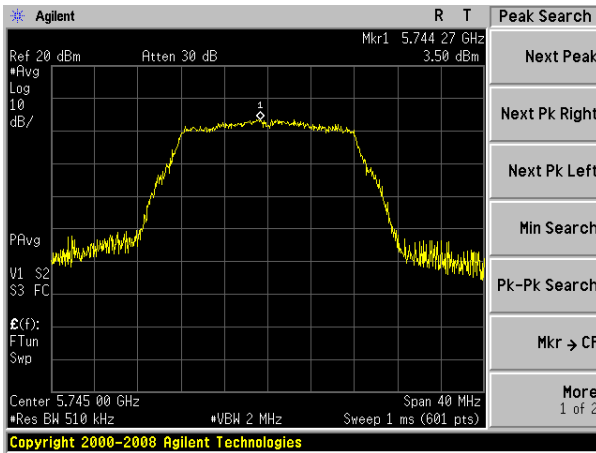

(802.11n20) PSD plot on channel 149

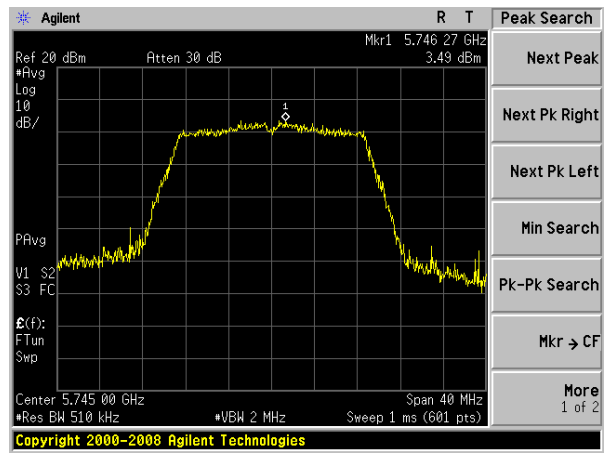

(802.11a) PSD plot on channel 157

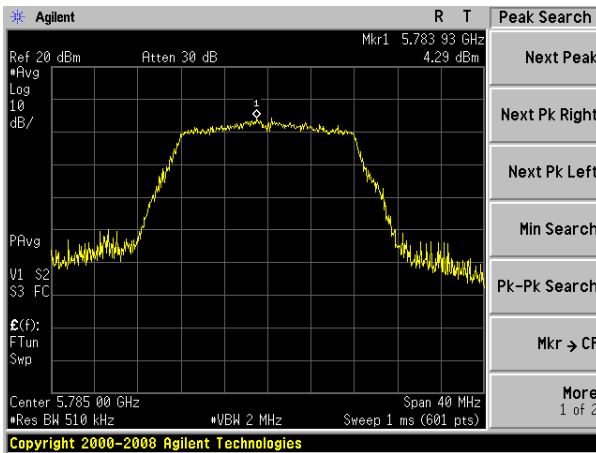

(802.11n20) PSD plot on channel 157

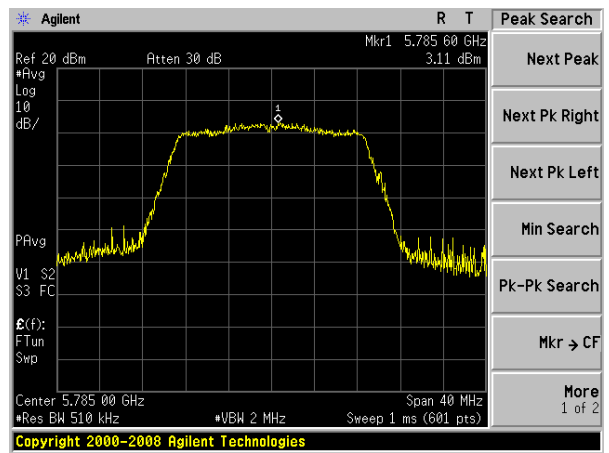

(802.11a) PSD plot on channel 165

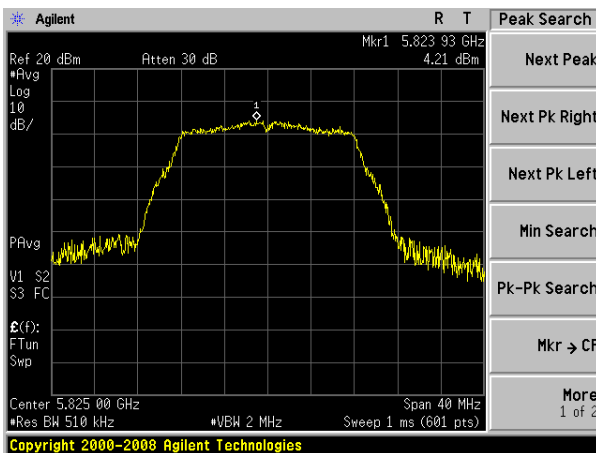

(802.11n20) PSD plot on channel 165

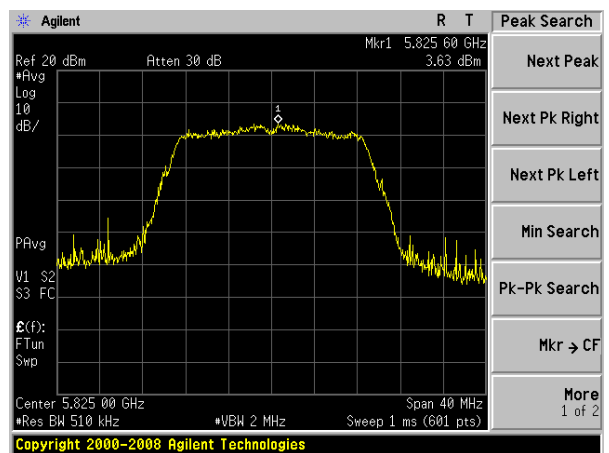

(802.11n40) PSD plot on channel 151

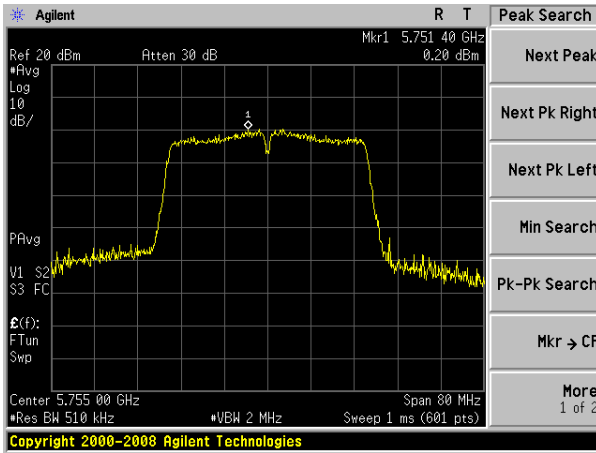

(802.11ac20) PSD plot on channel 149

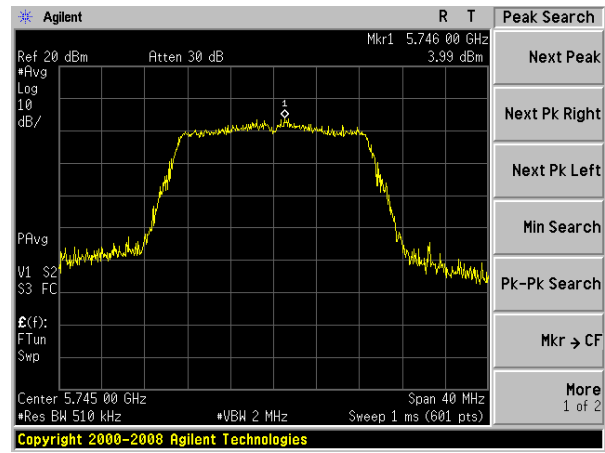

(802.11n40) PSD plot on channel 159

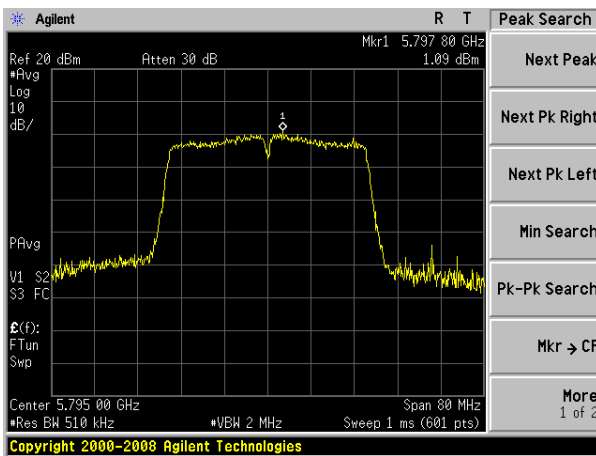

(802.11ac20) PSD plot on channel 157

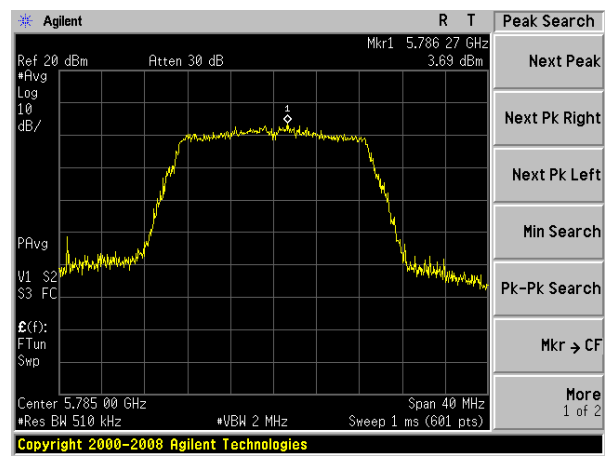

(802.11ac20) PSD plot on channel 165

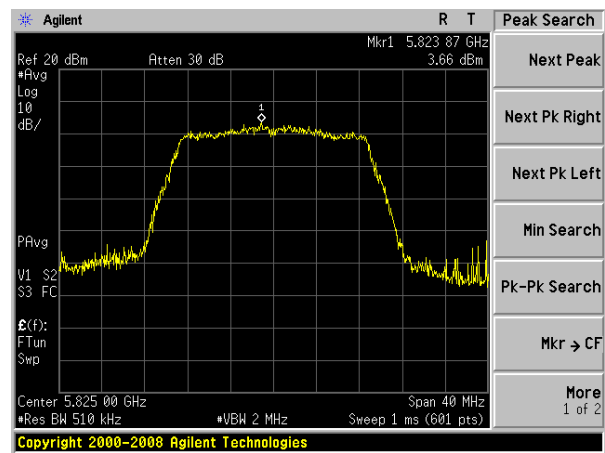

(802.11ac40) PSD plot on channel 151

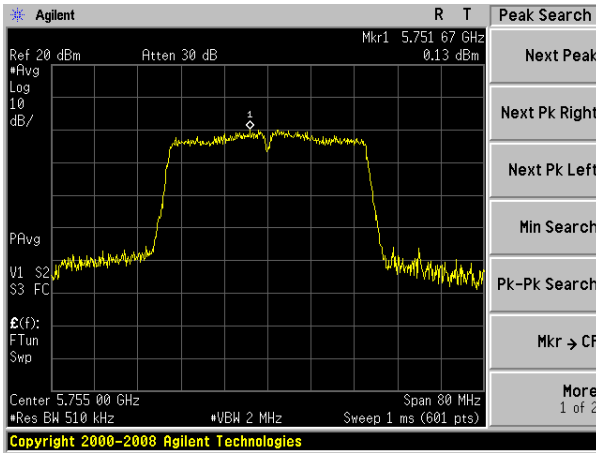

(802.11ac80) PSD plot on channel 155

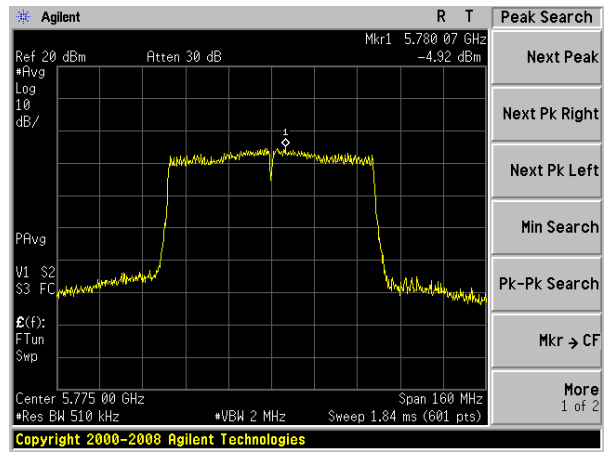

(802.11ac40) PSD plot on channel 159

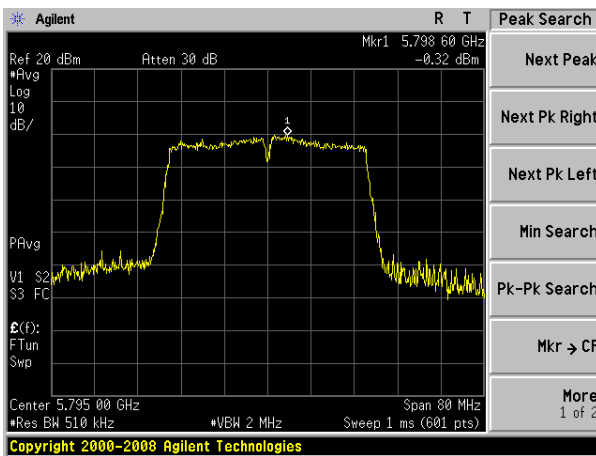

5. 26DB & 99% EMISSION BANDWIDTH

5.1 APPLIED PROCEDURES / LIMIT

The maximum power spectral density is measured as a conducted emission by direct connection of a calibrated test instrument to the equipment under test. If the device cannot be connected directly, alternative techniques acceptable to the Commission may be used. Measurements in the 5.725-5.85 GHz band are made over a reference bandwidth of 500 kHz or the 26 dB emission bandwidth of the device, whichever is less. Measurements in the 5.15-5.25 GHz, 5.25-5.35 GHz, and the 5.47-5.725 GHz bands are made over a bandwidth of 1 MHz or the 26 dB emission bandwidth of the device, whichever is less. A narrower resolution bandwidth can be used, provided that the measured power is integrated over the full reference bandwidth.

5.2 TEST PROCEDURE

- a) Set RBW = approximately 1% of the emission bandwidth.
- b) Set the VBW > RBW.
- c) Detector = Peak.
- d) Trace mode = max hold.
- e) Measure the maximum width of the emission that is 26 dB down from the maximum of the emission. Compare this with the RBW setting of the analyzer. Readjust RBW and repeat measurement as needed until the RBW/EBW ratio is approximately 1%.

The following procedure shall be used for measuring (99 %) power bandwidth:

- 1. Set center frequency to the nominal EUT channel center frequency.
- 2. Set span = 1.5 times to 5.0 times the OBW.
- 3. Set RBW = 1 % to 5 % of the OBW
- 4. Set VBW ≥ 3 · RBW
- 5. Video averaging is not permitted. Where practical, a sample detection and single sweep mode shall be used. Otherwise, peak detection and max hold mode (until the trace stabilizes) shall be used.
- 6. Use the 99 % power bandwidth function of the instrument (if available).
- 7. If the instrument does not have a 99 % power bandwidth function, the trace data points are recovered and directly summed in power units. The recovered amplitude data points, beginning at the lowest frequency, are placed in a running sum until 0.5 % of the total is reached; that frequency is recorded as the lower frequency. The process is repeated until 99.5 % of the total is reached; that frequency is recorded as the upper frequency. The 99% occupied bandwidth is the difference between these two frequencies.

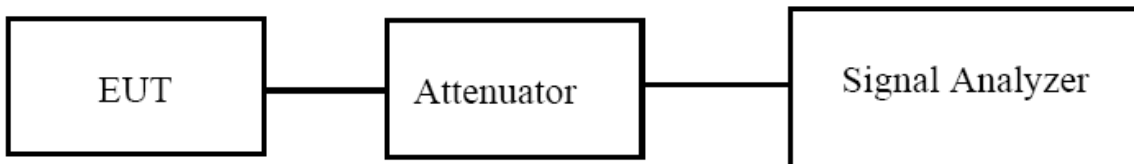

5.3 EUT OPERATION CONDITIONS

The EUT tested system was configured as the statements of 2.4 Unless otherwise a special operating condition is specified in the follows during the testing.

5.4 TEST RESULTS

EUT :	Wireless Digital Terminal	Model Name. :	S611
Temperature :	25 °C	Relative Humidity :	56%
Pressure :	1012 hPa	Test Voltage :	DC 3.85V
Test Mode :	TX Frequency Band 1 (5150-5250MHz)		

Mode	Channel	Frequency (MHz)	99% bandwidth(MHz)	26dB bandwidth (MHz)	Result
802.11a	CH36	5180	17.3859	27.917	Pass
	CH40	5200	17.1154	26.545	Pass
	CH48	5240	17.0586	26.534	Pass
802.11 n20	CH36	5180	18.0207	23.778	Pass
	CH40	5200	18.0897	23.968	Pass
	CH48	5240	18.0929	23.978	Pass
802.11 n40	CH 38	5190	36.4553	47.928	Pass
	CH 46	5230	36.4094	42.116	Pass
802.11 ac20	CH36	5180	18.0637	25.004	Pass
	CH40	5200	18.0489	24.355	Pass
	CH48	5240	18.0559	26.337	Pass
802.11 ac40	CH 38	5190	36.4456	49.395	Pass
	CH 46	5230	36.5435	46.782	Pass
802.11 ac80	CH 42	5210	75.7183	95.464	Pass

Test plot

(802.11a) -26dB&99%Bandwidth plot on channel 36

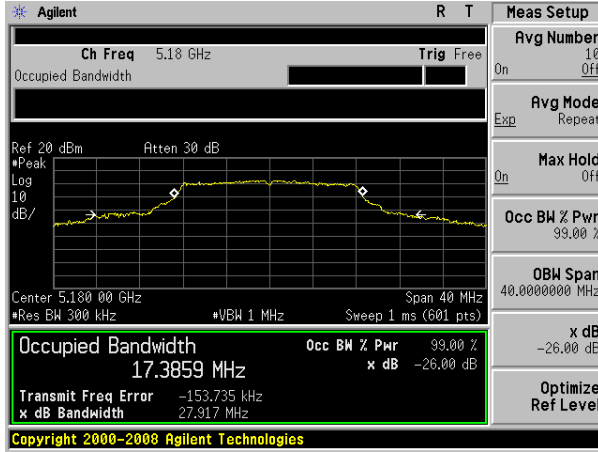

(802.11 n20) -26dB&99%Bandwidth plot on channel 36

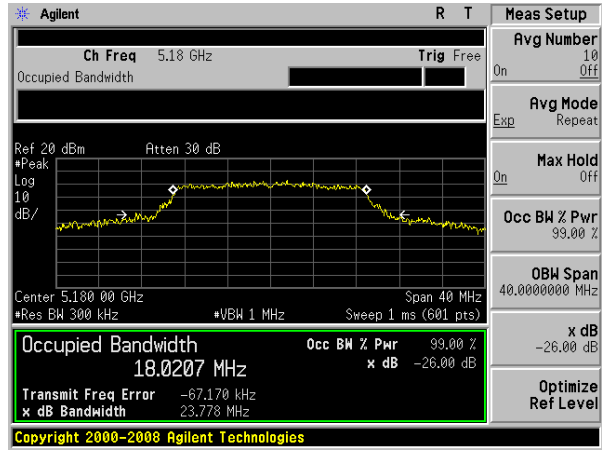

(802.11a) -26dB&99%Bandwidth plot on channel 40

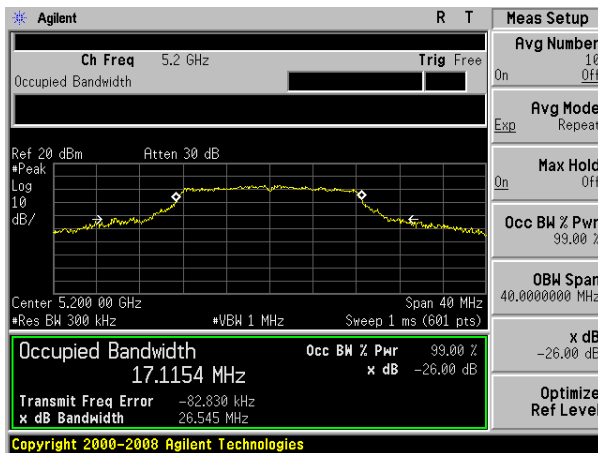

(802.11 n20) -26dB&99%Bandwidth plot on channel 40

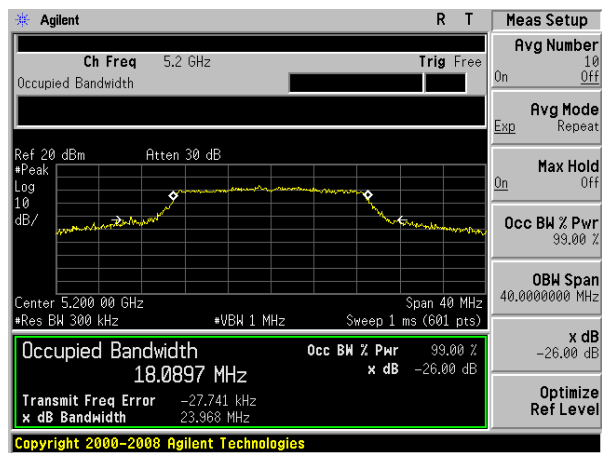

(802.11a) -26dB&99%Bandwidth plot on channel 48

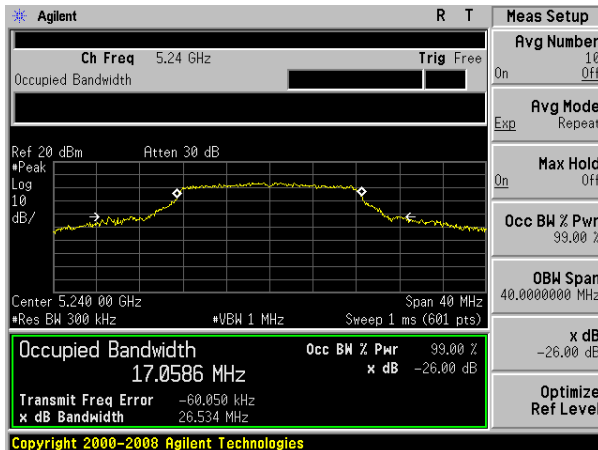

(802.11 n20) -26dB&99%Bandwidth plot on channel 48

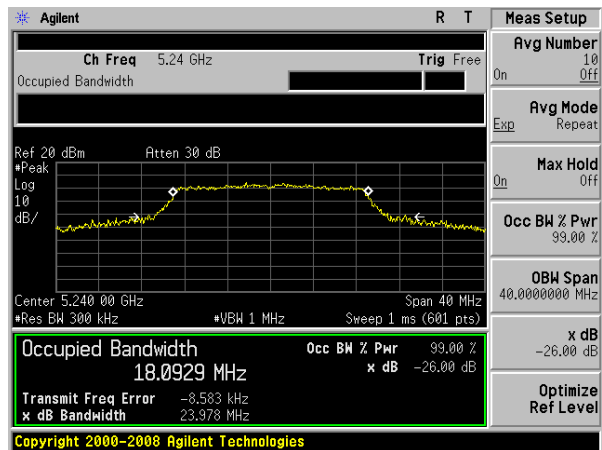

Test plot

(802.11 n40) -26dB&99%Bandwidth plot on channel 38

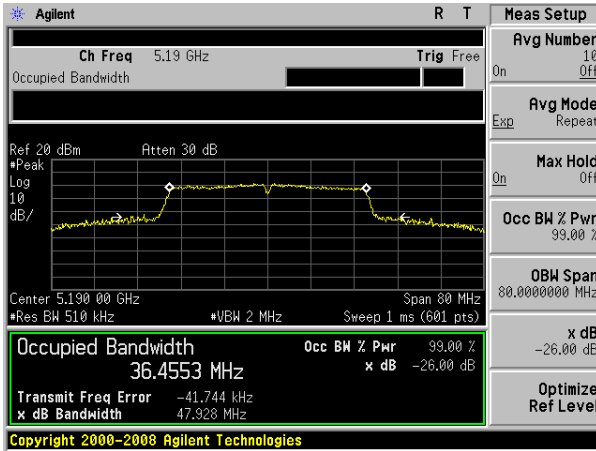

(802.11 ac20) -26dB&99%Bandwidth plot on channel 36

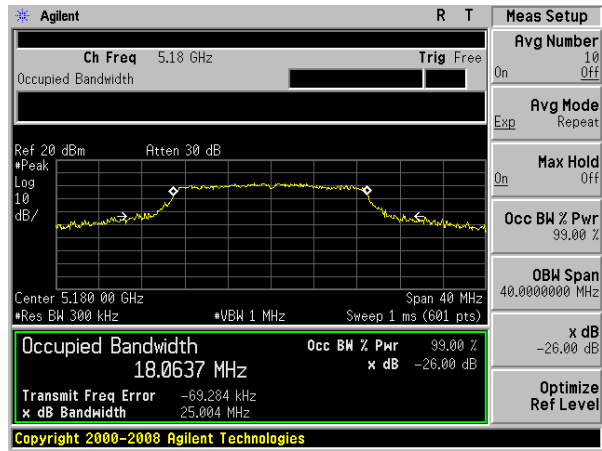

(802.11 n40) -26dB&99%Bandwidth plot on channel 46

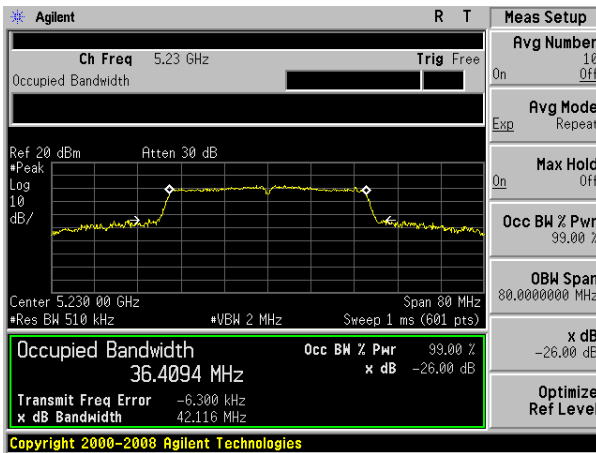

(802.11 ac20) -26dB&99%Bandwidth plot on channel 40

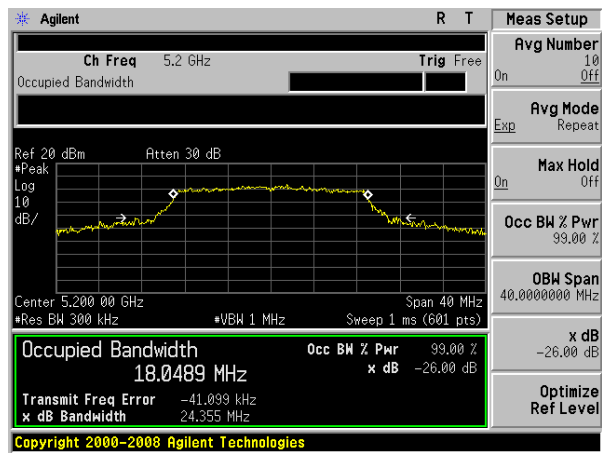

(802.11 ac20) -26dB&99%Bandwidth plot on channel 48

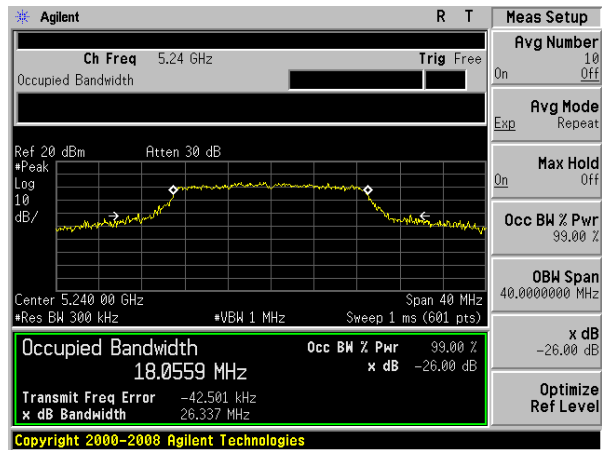

Test plot

(802.11 ac40) -26dB&99%Bandwidth plot on
channel 38

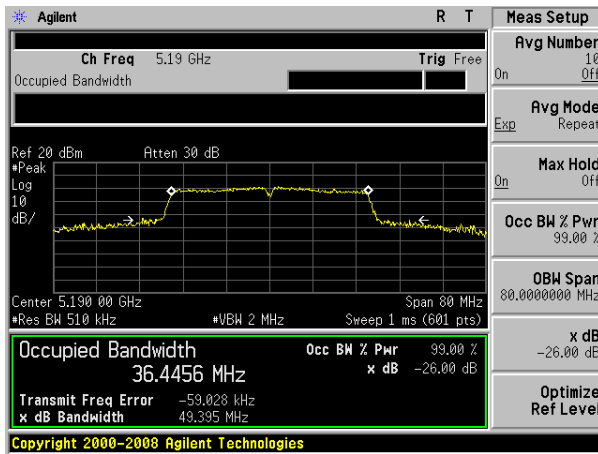

(802.11 ac80) -26dB&99%Bandwidth plot on
channel 42

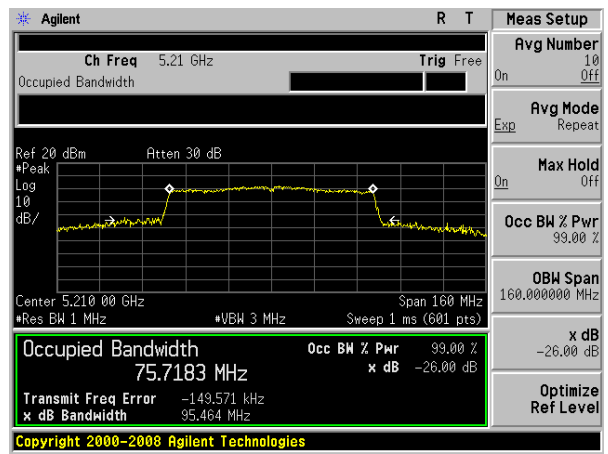

(802.11 ac40) -26dB&99%Bandwidth plot on
channel 46

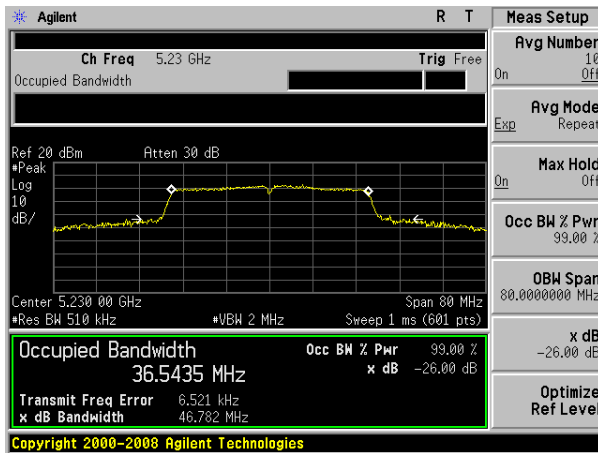

EUT :	Wireless Digital Terminal	Model Name. :	S611
Temperature :	25 °C	Relative Humidity :	56%
Pressure :	1012 hPa	Test Voltage :	DC 3.85V
Test Mode :	TX Frequency Band 2A (5250-5350MHz)		

Mode	Channel	Frequency (MHz)	99% bandwidth(MHz)	26dB bandwidth (MHz)	Result
802.11a	CH52	5260	16.9161	21.575	Pass
	CH56	5280	16.8180	21.409	Pass
	CH64	5320	16.8493	21.242	Pass
802.11 n20	CH52	5260	17.8694	21.435	Pass
	CH56	5280	17.9372	21.472	Pass
	CH64	5320	17.8671	21.382	Pass
802.11 n40	CH 54	5270	36.0905	39.752	Pass
	CH 62	5310	36.1674	40.018	Pass
802.11 ac20	CH52	5260	17.8457	21.521	Pass
	CH56	5280	17.8423	21.578	Pass
	CH64	5320	17.9039	21.358	Pass
802.11 ac40	CH 54	5270	36.2944	39.890	Pass
	CH 62	5310	36.2018	39.981	Pass
802.11 ac80	CH 58	5290	75.2999	80.960	Pass

Test plot

(802.11a) -26dB&99%Bandwidth plot on channel 52

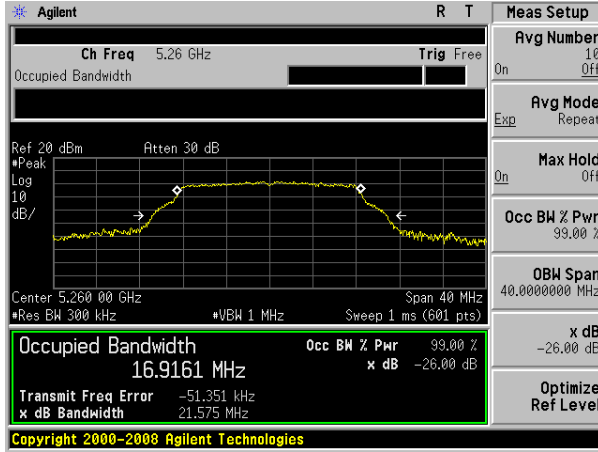

(802.11 n20) -26dB&99%Bandwidth plot on channel 52

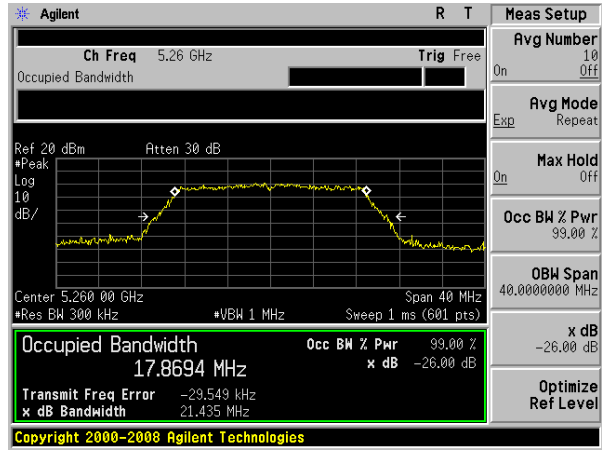

(802.11a) -26dB&99%Bandwidth plot on channel 56

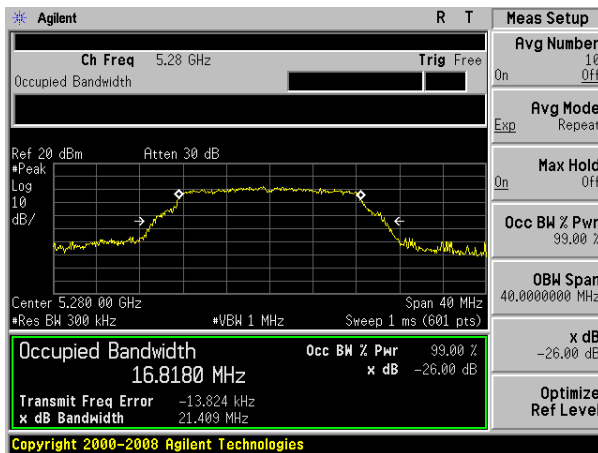

(802.11 n20) -26dB&99%Bandwidth plot on channel 56

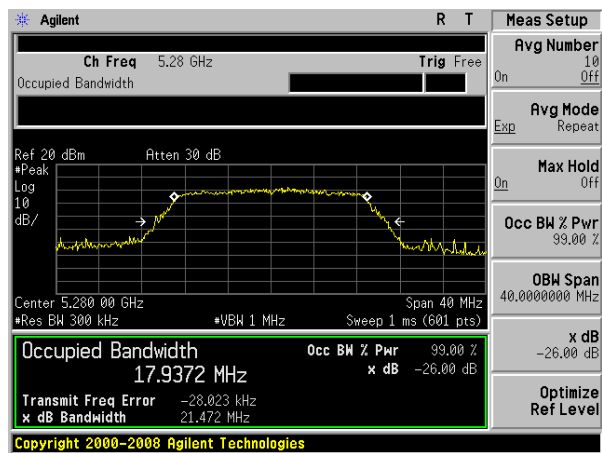

(802.11a) -26dB&99%Bandwidth plot on channel 62

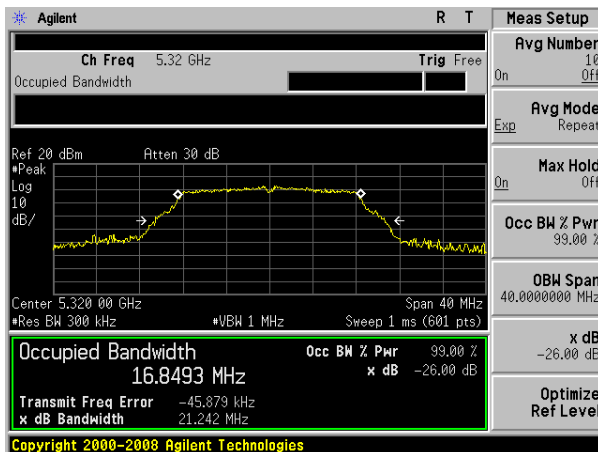

(802.11 n20) -26dB&99%Bandwidth plot on channel 62

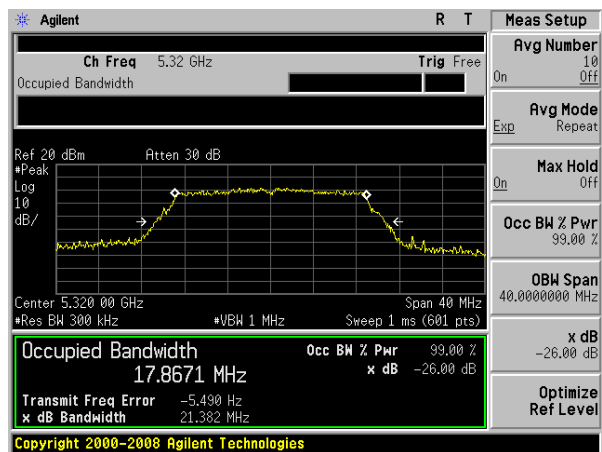

Test plot

(802.11 n40) -26dB&99%Bandwidth plot on channel 54

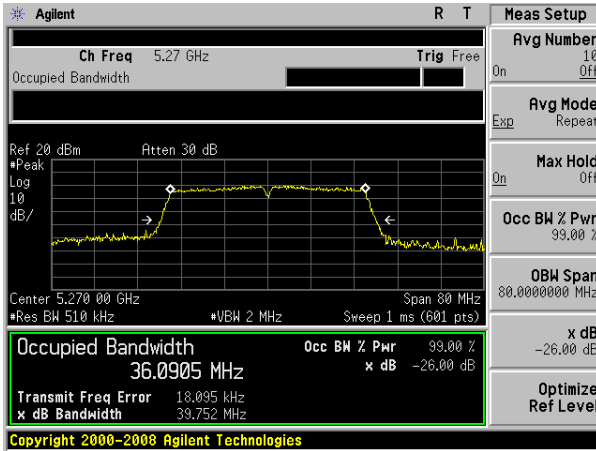

(802.11 ac20) -26dB&99%Bandwidth plot on channel 52

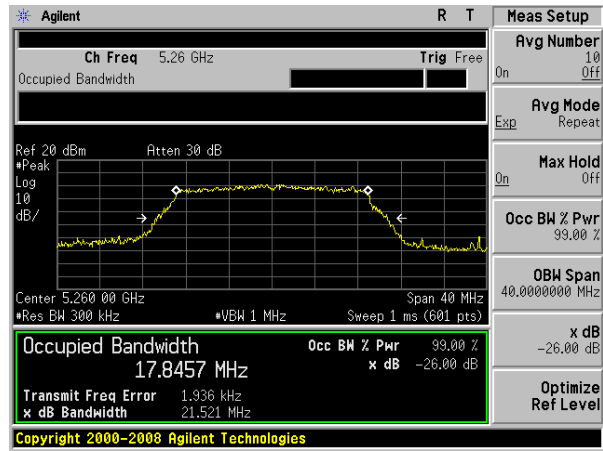

(802.11 n40) -26dB&99%Bandwidth plot on channel 62

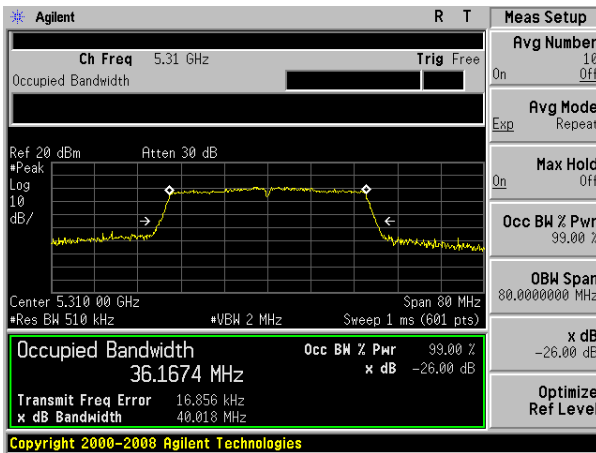

(802.11 ac20) -26dB&99%Bandwidth plot on channel 56

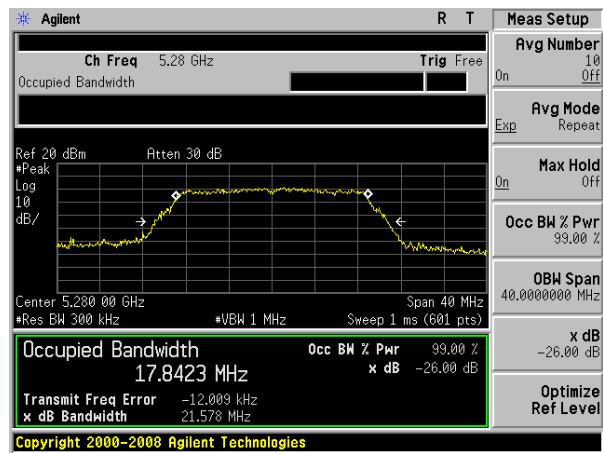

(802.11 ac20) -26dB&99%Bandwidth plot on channel 64

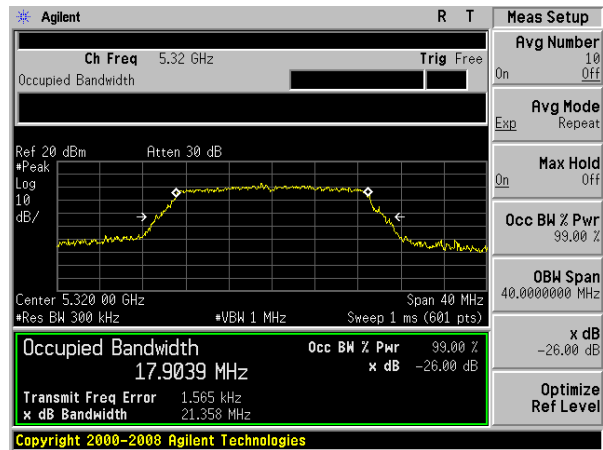

Test plot

(802.11 ac40) -26dB&99%Bandwidth plot on channel 54

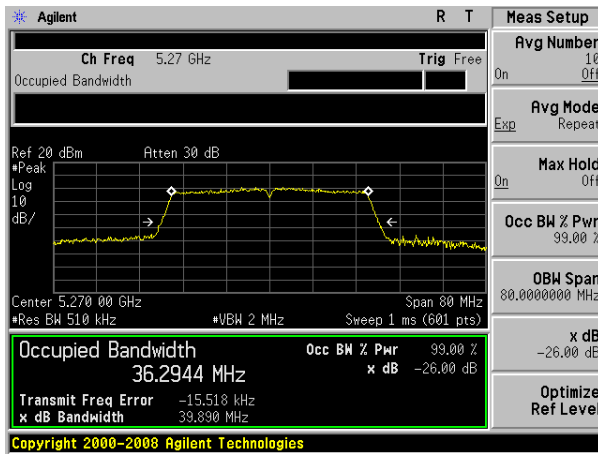

(802.11 ac80) -26dB&99%Bandwidth plot on channel 58

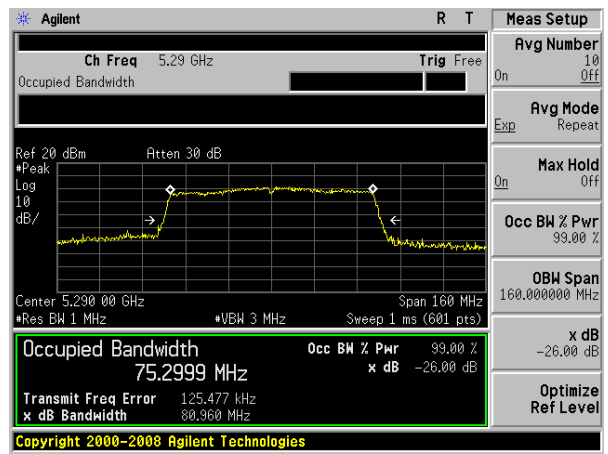

(802.11 ac40) -26dB&99%Bandwidth plot on channel 62

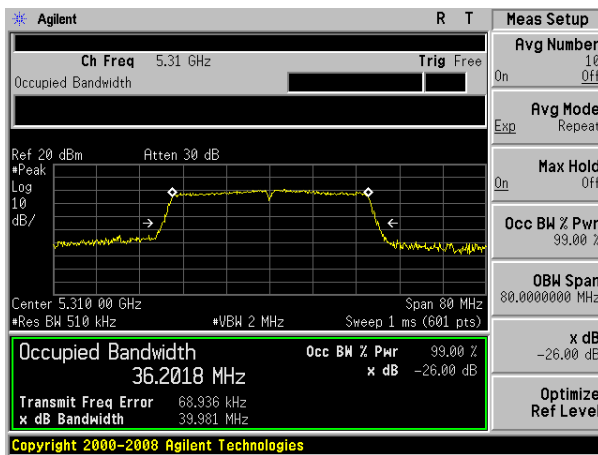

EUT :	Wireless Digital Terminal	Model Name. :	S611
Temperature :	25 °C	Relative Humidity :	56%
Pressure :	1012 hPa	Test Voltage :	DC 3.85V
Test Mode :	TX Frequency Band 2C(5470-5725MHz)		

Mode	Channel	Frequency (MHz)	99% bandwidth(MHz)	26dB bandwidth (MHz)	Result
802.11a	CH100	5500	16.8691	21.195	Pass
	CH120	5600	16.8511	21.292	Pass
	CH140	5700	16.8120	21.638	Pass
802.11 n20	CH100	5500	17.9012	21.515	Pass
	CH120	5600	17.9299	21.542	Pass
	CH140	5700	17.8587	21.287	Pass
802.11 n40	CH102	5510	36.3468	40.003	Pass
	CH118	5590	36.2546	39.722	Pass
	CH134	5670	36.2293	39.763	Pass
802.11 ac20	CH100	5500	17.9505	21.504	Pass
	CH120	5600	17.9781	21.589	Pass
	CH140	5700	17.9234	21.388	Pass
802.11 ac40	CH102	5510	36.3066	39.973	Pass
	CH118	5590	36.1900	39.723	Pass
	CH134	5670	36.2800	39.779	Pass
802.11 ac80	CH106	5530	75.5913	81.983	Pass
802.11 ac80	CH122	5610	75.5744	81.540	Pass

Test plot

(802.11a) -26dB&99%Bandwidth plot on channel 100

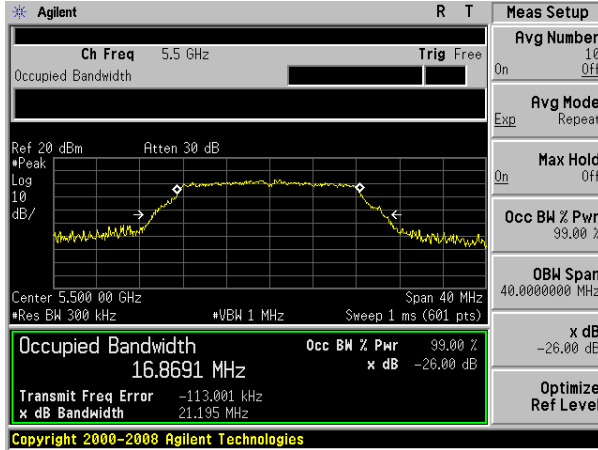

(802.11 n20) -26dB&99%Bandwidth plot on channel 100

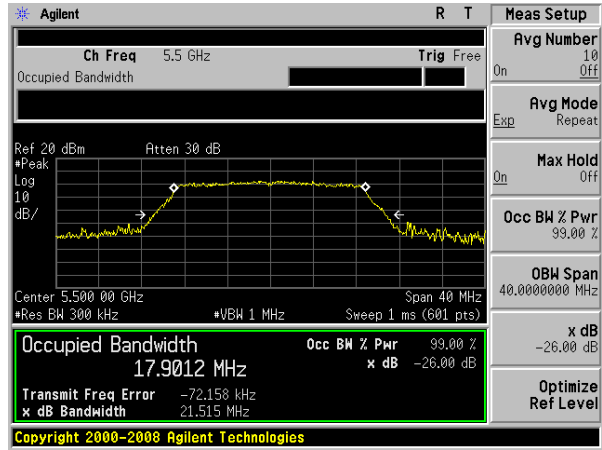

(802.11a) -26dB&99%Bandwidth plot on channel 120

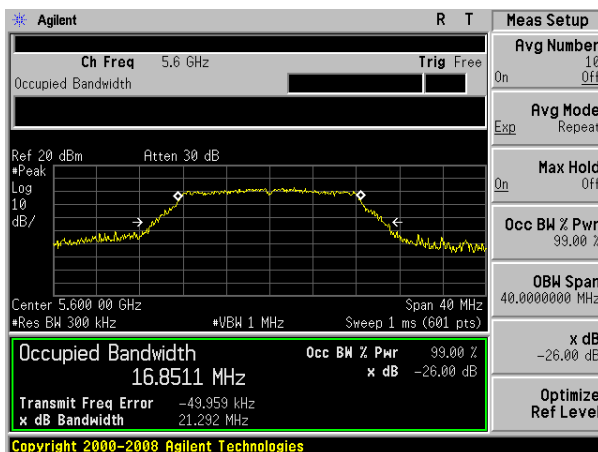

(802.11 n20) -26dB&99%Bandwidth plot on channel 120

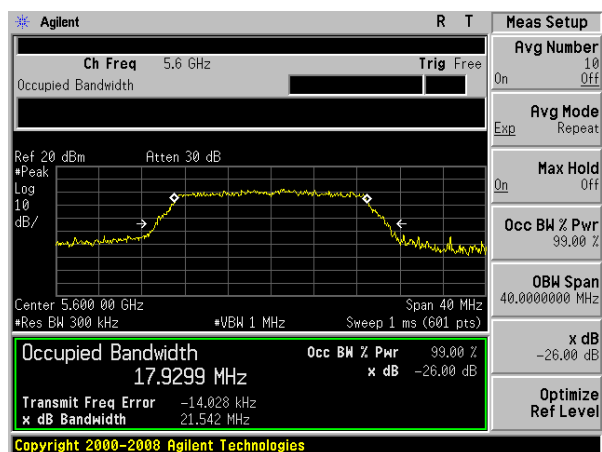

(802.11a) -26dB&99%Bandwidth plot on channel 140

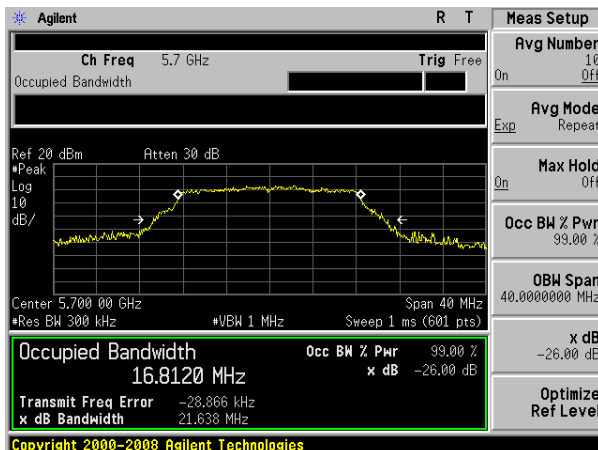

(802.11 n20) -26dB&99%Bandwidth plot on channel 140

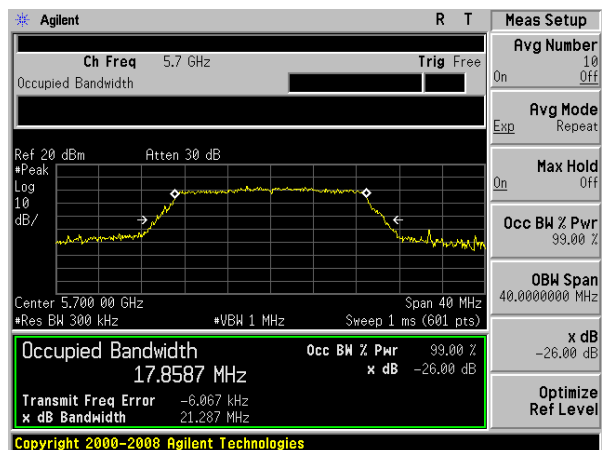

Test plot

(802.11 n40) -26dB&99%Bandwidth plot on channel 102

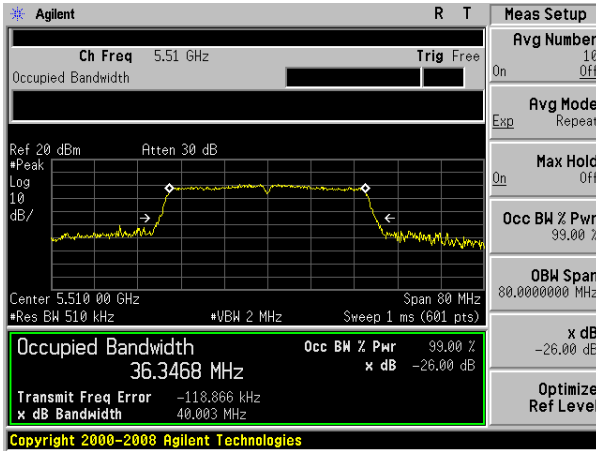

(802.11 ac20) -26dB&99%Bandwidth plot on channel 100

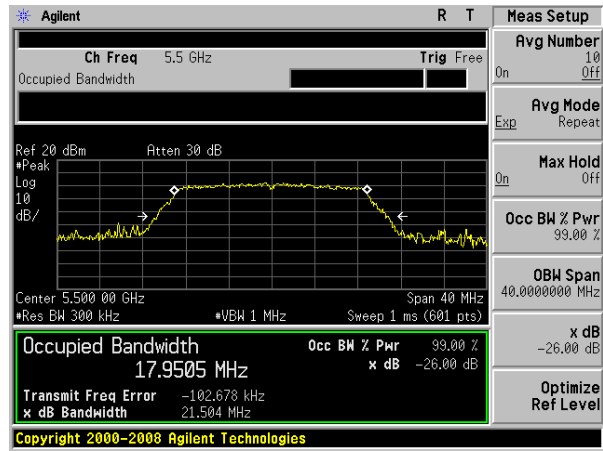

(802.11 n40) -26dB&99%Bandwidth plot on channel 118

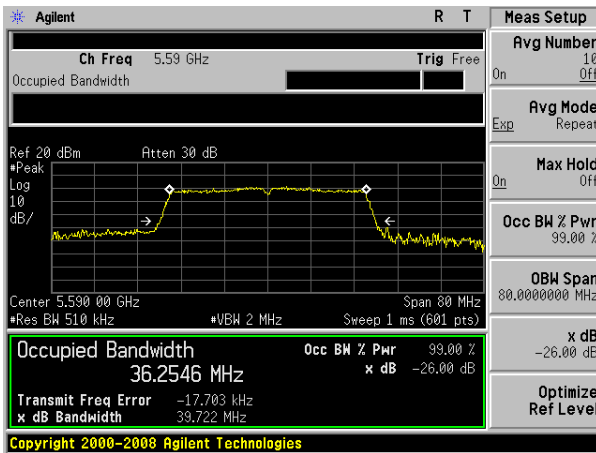

(802.11 ac20) -26dB&99%Bandwidth plot on channel 120

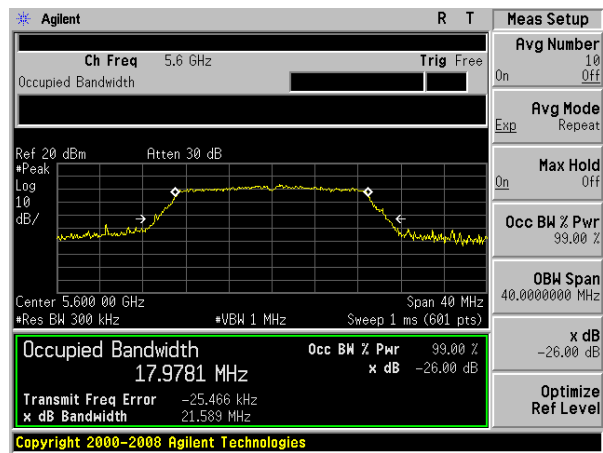

(802.11 n40) -26dB&99%Bandwidth plot on channel 134

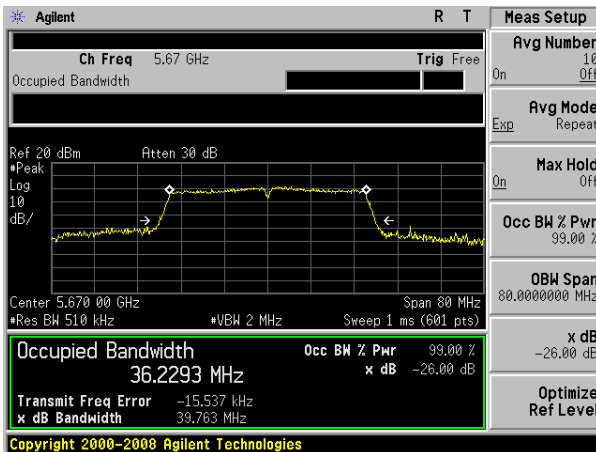

(802.11 ac20) -26dB&99%Bandwidth plot on channel 140

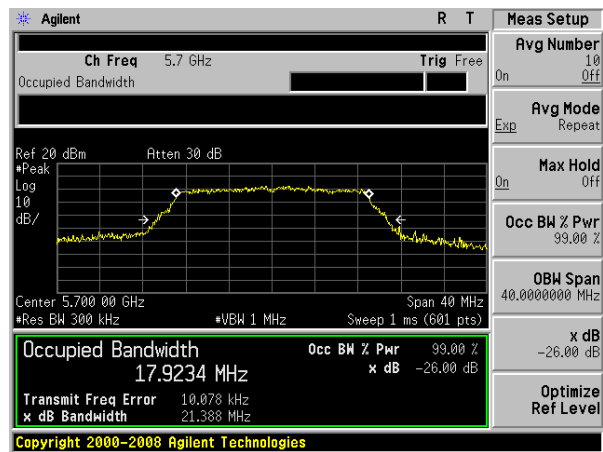

Test plot

(802.11 ac40) -26dB&99%Bandwidth plot on channel 102

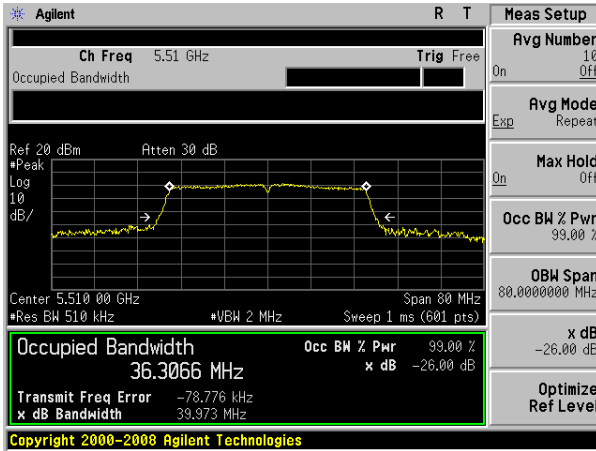

(802.11 ac80) -26dB&99%Bandwidth plot on channel 106

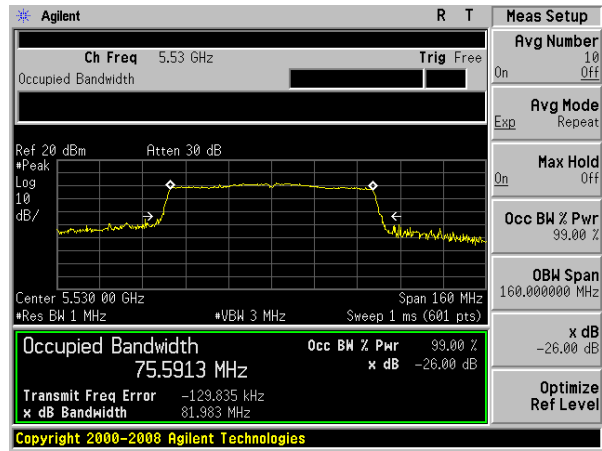

(802.11 ac40) -26dB&99%Bandwidth plot on channel 118

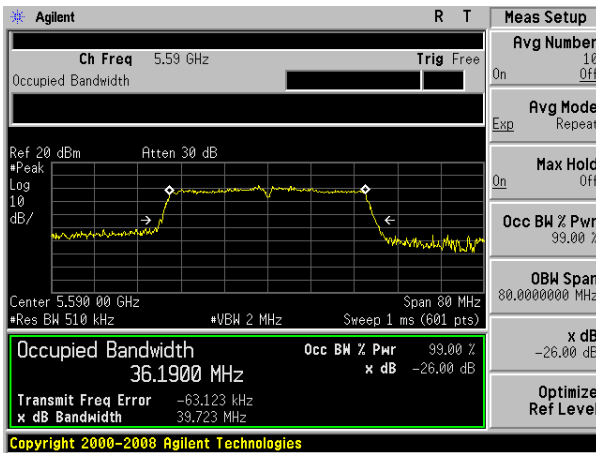

(802.11 ac80) -26dB&99%Bandwidth plot on channel 122

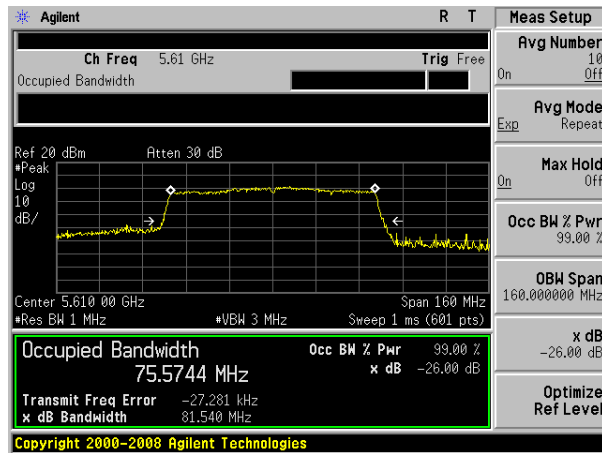

(802.11 ac40) -26dB&99%Bandwidth plot on channel 134

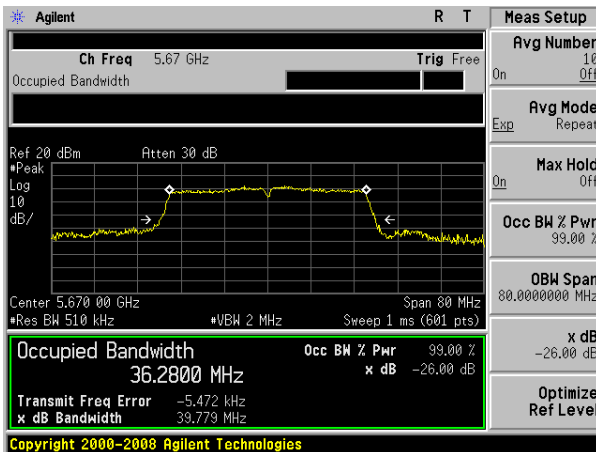

EUT :	Wireless Digital Terminal	Model Name. :	S611
Temperature :	25 °C	Relative Humidity :	56%
Pressure :	1012 hPa	Test Voltage :	DC 3.85V
Test Mode :	TX Frequency Band 3(5725-5850MHz)		

Mode	Channel	Frequency (MHz)	99% bandwidth(MHz)	26dB bandwidth (MHz)	Result
802.11a	CH149	5745	16.8655	21.249	Pass
	CH157	5785	16.7599	21.146	Pass
	CH165	5825	16.8437	21.204	Pass
802.11 n20	CH149	5745	17.9482	21.361	Pass
	CH157	5785	17.8656	21.424	Pass
	CH165	5825	17.9144	21.465	Pass
802.11 n40	CH151	5755	36.2103	39.712	Pass
	CH159	5795	36.1877	39.600	Pass
802.11 ac20	CH149	5745	17.8505	21.515	Pass
	CH157	5785	17.9375	21.443	Pass
	CH165	5825	17.9299	21.384	Pass
802.11 ac40	CH151	5755	36.2910	40.034	Pass
	CH159	5795	36.2247	39.660	Pass
802.11 ac80	CH155	5775	75.4726	81.214	Pass

Test plot

(802.11a) -26dB&99%Bandwidth plot on channel 149

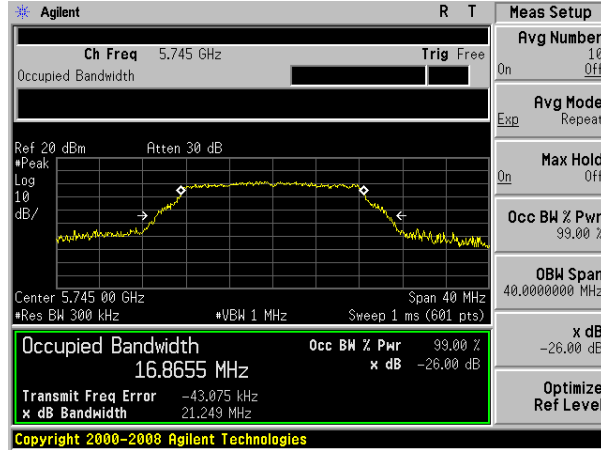

(802.11 n20) -26dB&99%Bandwidth plot on channel 149

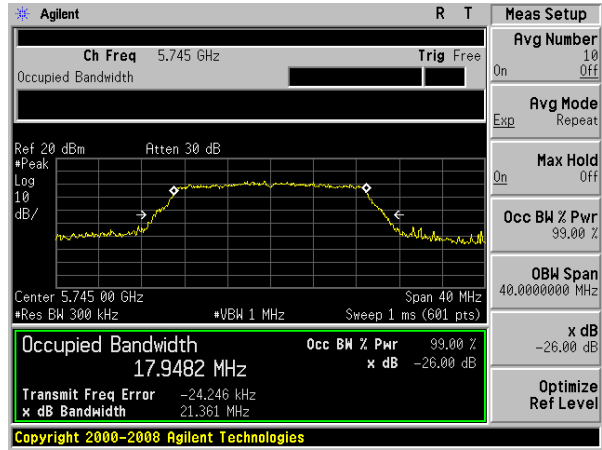

(802.11a) -26dB&99%Bandwidth plot on channel 157

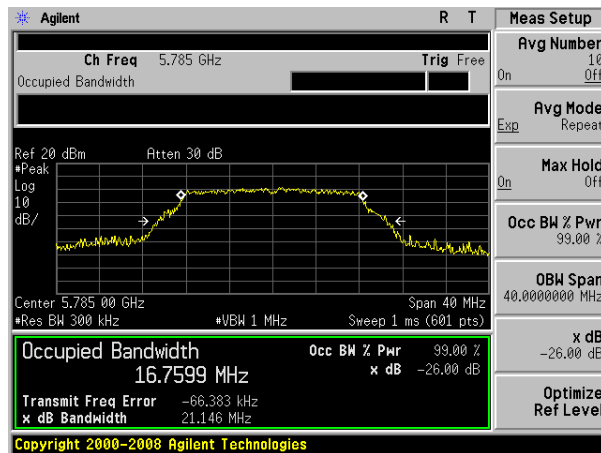

(802.11 n20) -26dB&99%Bandwidth plot on channel 157

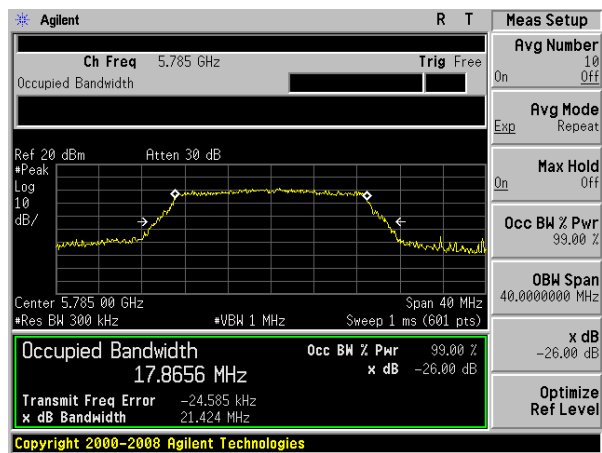

(802.11a) -26dB&99%Bandwidth plot on channel 165

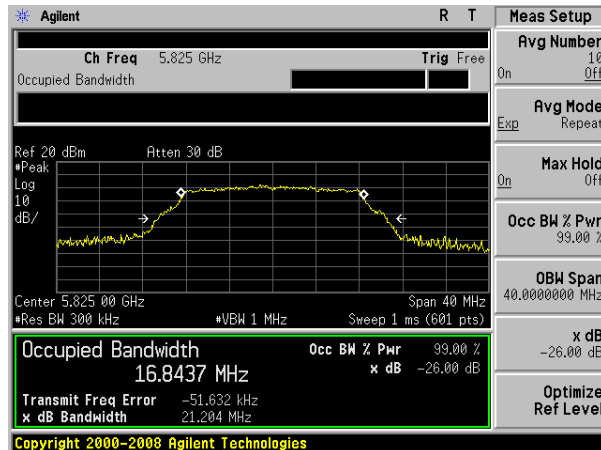

(802.11 n20) -26dB&99%Bandwidth plot on channel 165

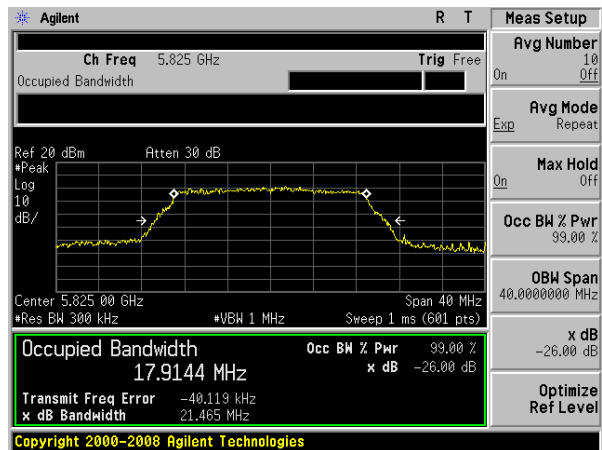

Test plot

(802.11 n40) -26dB&99%Bandwidth plot on channel 151

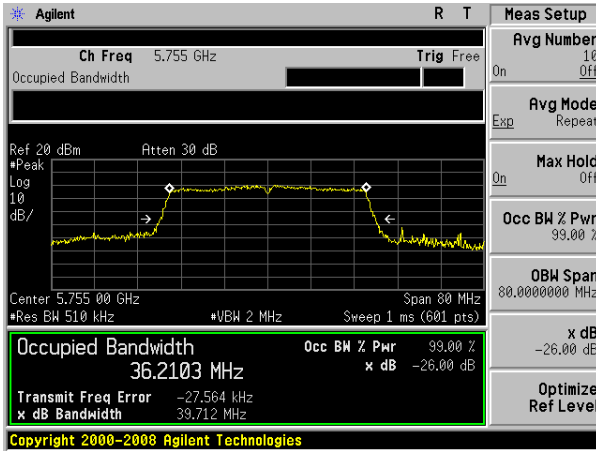

(802.11 ac20) -26dB&99%Bandwidth plot on channel 149

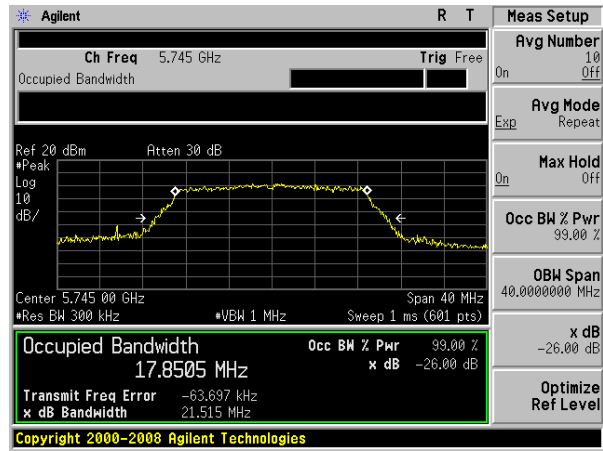

(802.11 n40) -26dB&99%Bandwidth plot on channel 159

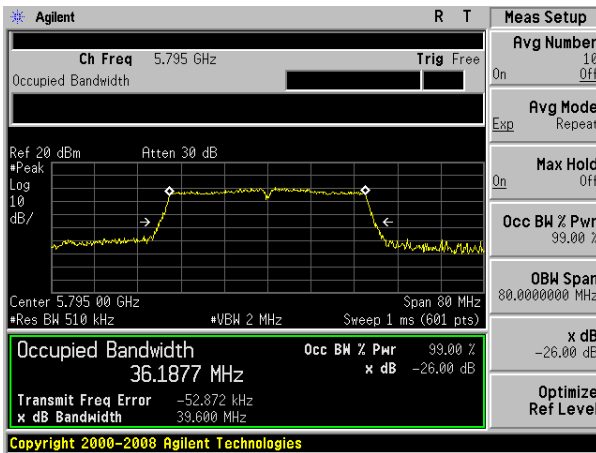

(802.11 ac20) -26dB&99%Bandwidth plot on channel 157

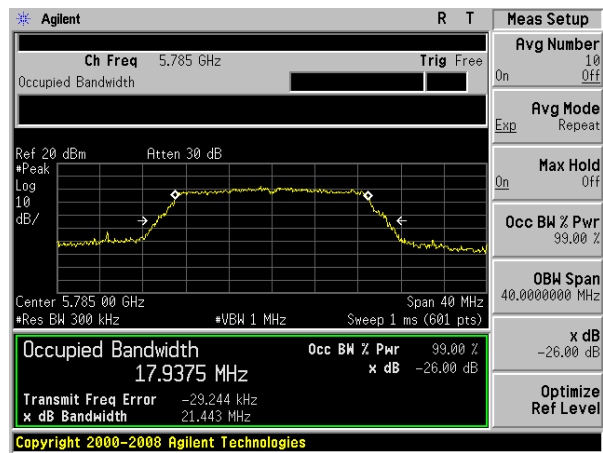

(802.11 ac20) -26dB&99%Bandwidth plot on channel 165

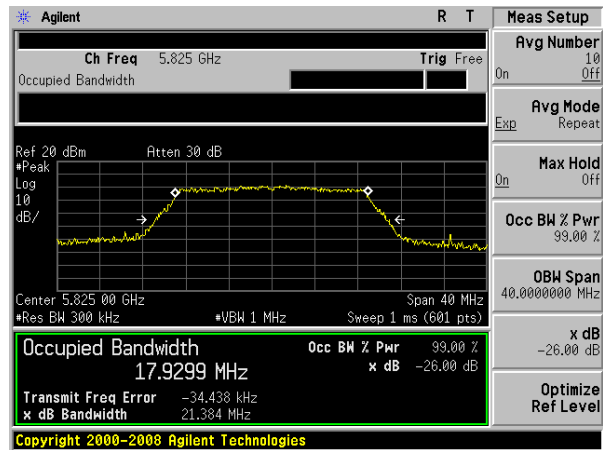

Test plot

(802.11 ac40) -26dB&99%Bandwidth plot on channel 151

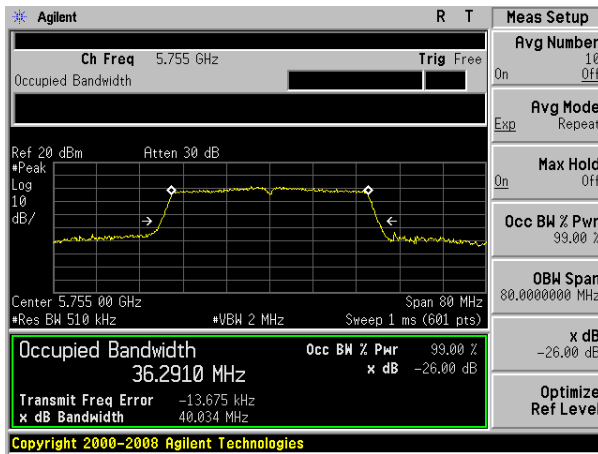

(802.11 ac80) -26dB&99%Bandwidth plot on channel 155

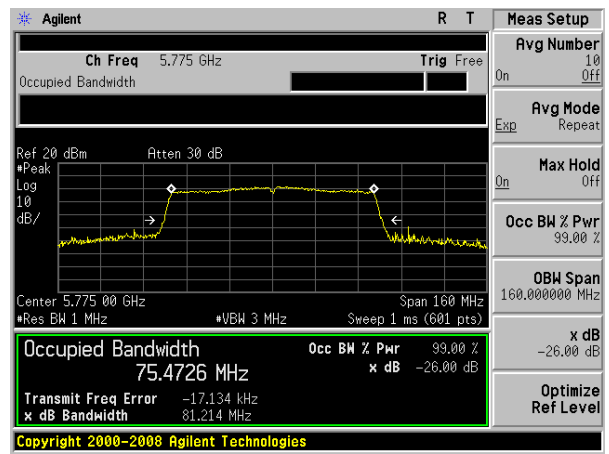

(802.11 ac40) -26dB&99%Bandwidth plot on channel 159

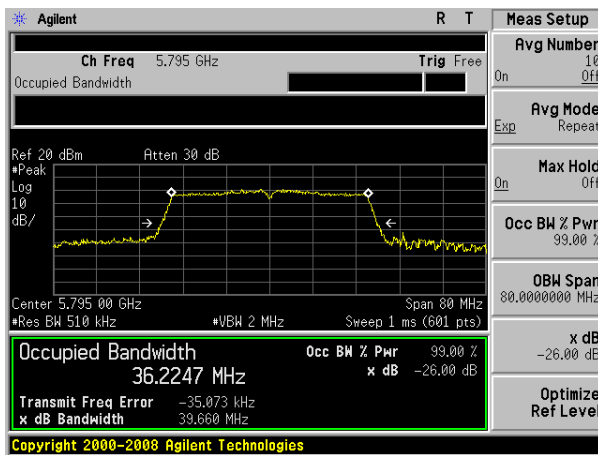

6. MINIMUM 6 DB BANDWIDTH

6.1 APPLIED PROCEDURES / LIMIT

According to FCC §15.407(e)

(e) Within the 5.725-5.85 GHz band, the minimum 6 dB bandwidth of U-NII devices shall be at least 500 kHz.

6.2 TEST PROCEDURE

Section 15.407(e) specifies the minimum 6 dB emission bandwidth of at least 500 KHz for the band 5.715-5.85 GHz. The following procedure shall be used for measuring this bandwidth:

- a) Set RBW = 100 kHz.
- b) Set the video bandwidth (VBW) $\geq 3 \times$ RBW.
- c) Detector = Peak.
- d) Trace mode = max hold.
- e) Sweep = auto couple.
- f) Allow the trace to stabilize.
- g) Measure the maximum width of the emission that is constrained by the frequencies associated with the two outermost amplitude points (upper and lower frequencies) that are attenuated by 6 dB relative to the maximum level measured in the fundamental emission.

6.3 DEVIATION FROM STANDARD

No deviation.

6.4 TEST SETUP

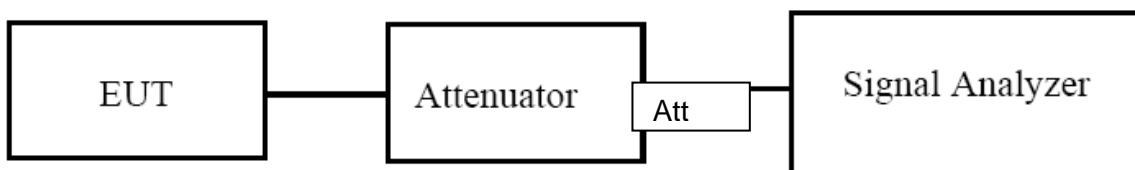

6.5 EUT OPERATION CONDITIONS

The EUT tested system was configured as the statements of 2.4 Unless otherwise a special operating condition is specified in the follows during the testing.

6.6 TEST RESULTS

EUT :	Wireless Digital Terminal	Model Name. :	S611
Temperature :	25 °C	Relative Humidity :	60%
Pressure :	1012 hPa	Test Voltage :	DC 3.85V
Test Mode :	TX (5G) Mode Frequency Band 3 (5725-5850MHz)		

Mode	Channel	Frequency (MHz)	-6dB bandwidth (MHz)	Limit (KHz)	Result
802.11a	149	5745	16.385	≧ 500	Pass
	157	5785	16.428	≧ 500	Pass
	165	5825	15.820	≧ 500	Pass
802.11 n20	149	5745	17.620	≧ 500	Pass
	157	5785	17.612	≧ 500	Pass
	165	5825	17.641	≧ 500	Pass
802.11 n40	151	5755	35.603	≧ 500	Pass
	159	5795	35.911	≧ 500	Pass
802.11 ac20	149	5745	17.656	≧ 500	Pass
	157	5785	17.310	≧ 500	Pass
	165	5825	17.563	≧ 500	Pass
802.11 ac40	149	5745	35.874	≧ 500	Pass
	157	5785	35.823	≧ 500	Pass
802.11 ac80	155	5775	75.684	≧ 500	Pass

Test plot

(802.11a) 6dB Bandwidth plot on channel 149

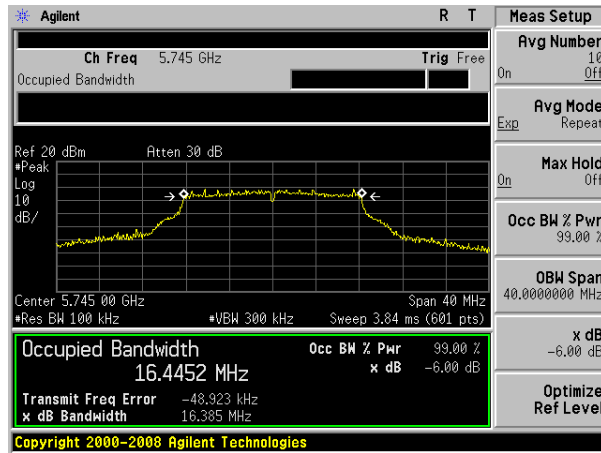

(802.11 n20) 6dB Bandwidth plot on channel 149

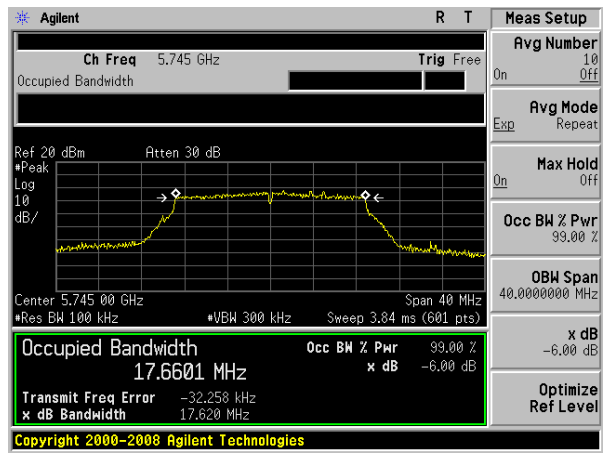

(802.11a) 6dB Bandwidth plot on channel 157

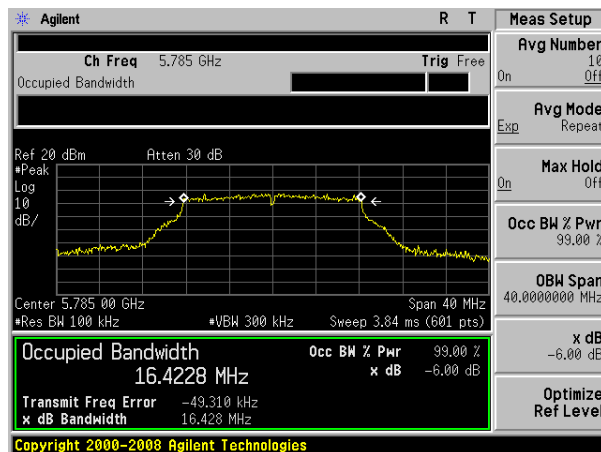

(802.11 n20) 6dB Bandwidth plot on channel 157

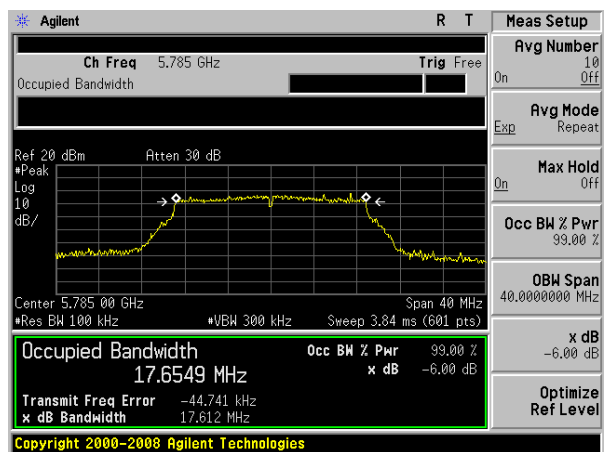

(802.11a) 6dB Bandwidth plot on channel 165

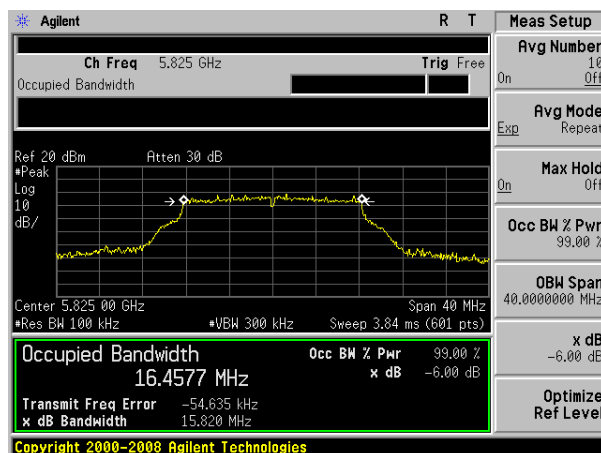

(802.11 n20) 6dB Bandwidth plot on channel 165

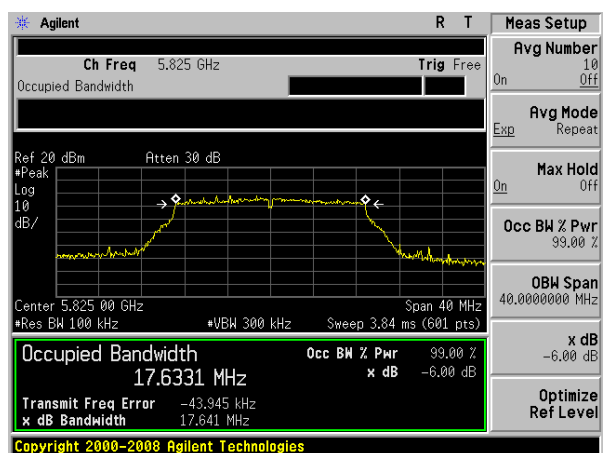

Test plot

(802.11 n40) 6dB Bandwidth plot on channel 151

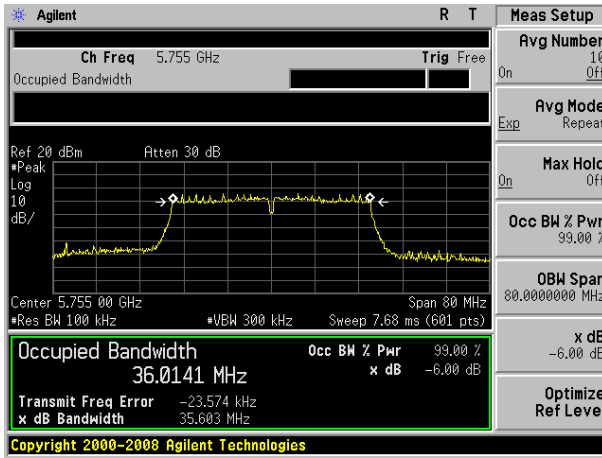

(802.11 ac20) 6dB Bandwidth plot on channel 149

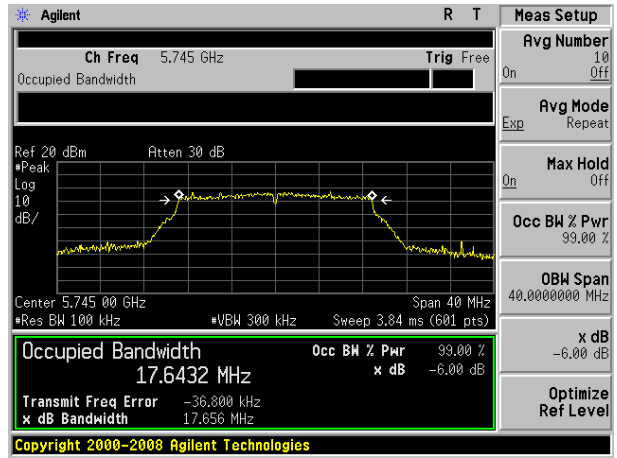

(802.11 n40) 6dB Bandwidth plot on channel 159

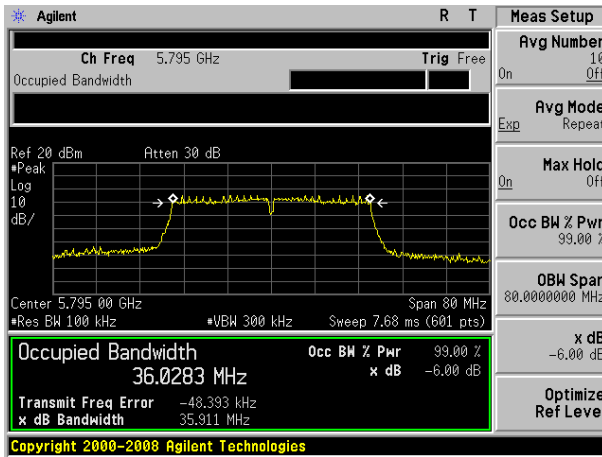

(802.11 ac20) 6dB Bandwidth plot on channel 157

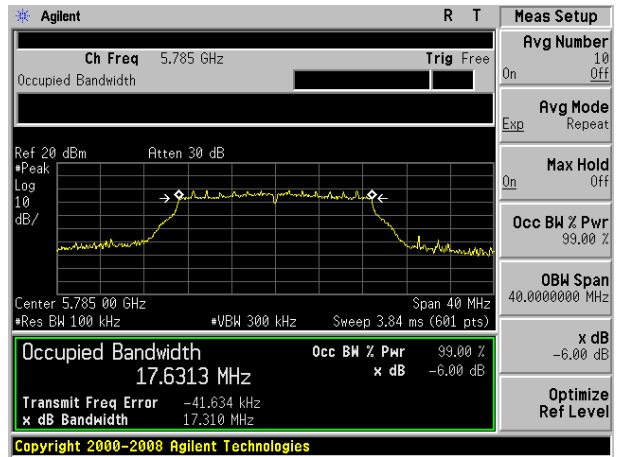

(802.11 ac20) 6dB Bandwidth plot on channel 165

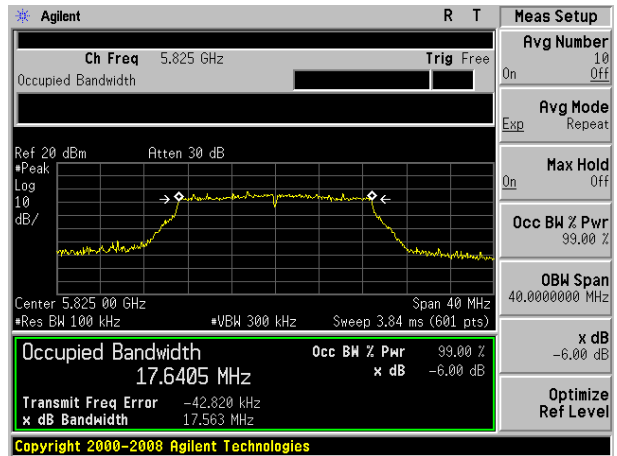

Test plot

(802.11 ac40) 6dB Bandwidth plot on channel 151

(802.11 ac80) 6dB Bandwidth plot on channel 155

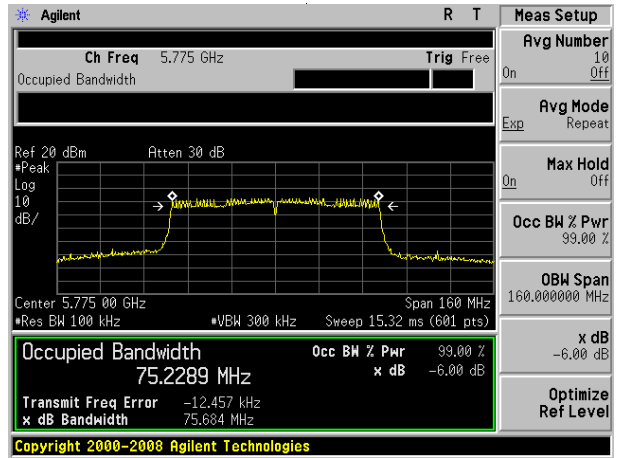
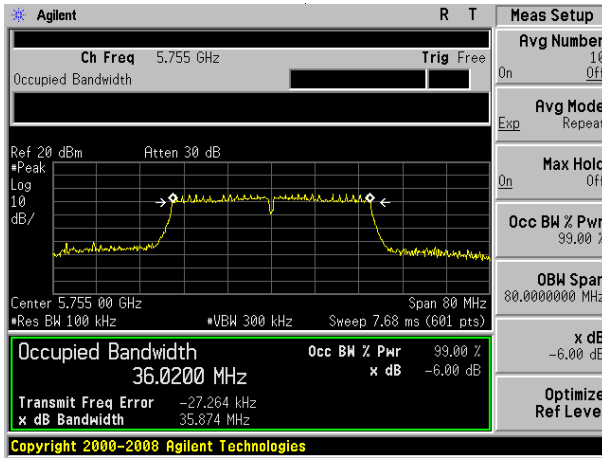

(802.11 ac40) 6dB Bandwidth plot on channel 159

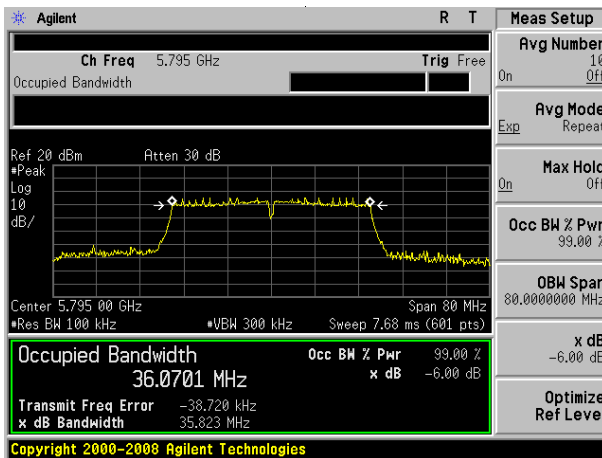

7. MAXIMUM CONDUCTED OUTPUT POWER

7.1 APPLIED PROCEDURES / LIMIT

According to FCC §15.407

The maximum conducted output power should not exceed:

Frequency Band(MHz)	Limit
5150~5250	250mW
5250~5350	250 mW or 11 dBm + 10 log B (Note)
5470~5725	250 mW or 11 dBm + 10 log B (Note)
5725~5850	1W

Note: the maximum conducted output power over the frequency bands of operation shall not exceed the lesser of 250 mW or 11 dBm + 10 log B, where B is the 26 dB emission bandwidth in megahertz.

7.2 TEST PROCEDURE

- Maximum conducted output power may be measured using a spectrum analyzer/EMI receiver or an RF power meter.

1. Device Configuration

If possible, configure or modify the operation of the EUT so that it transmits continuously at its maximum power control level (see section II.B.).

a) The intent is to test at 100 percent duty cycle; however a small reduction in duty cycle (to no lower than 98 percent) is permitted if required by the EUT for amplitude control purposes. Manufacturers are expected to provide software to the test lab to permit such continuous operation.

b) If continuous transmission (or at least 98 percent duty cycle) cannot be achieved due to hardware limitations (e.g., overheating), the EUT shall be operated at its maximum power control level with the transmit duration as long as possible and the duty cycle as high as possible.

2. Measurement using a Spectrum Analyzer or EMI Receiver (SA)

Measurement of maximum conducted output power using a spectrum analyzer requires integrating the spectrum across a frequency span that encompasses, at a minimum, either the EBW or the 99-percent occupied bandwidth of the signal.¹ However, the EBW must be used to determine bandwidth dependent limits on maximum conducted output power in accordance with § 15.407(a).

a) The test method shall be selected as follows: (i) Method SA-1 or SA-1 Alternative (averaging with the EUT transmitting at full power throughout each sweep) shall be applied if either of the following conditions can be satisfied:

- The EUT transmits continuously (or with a duty cycle ≥ 98 percent).
- Sweep triggering or gating can be implemented in a way that the device transmits at the maximum power control level throughout the duration of each of the instrument sweeps to be averaged. This condition can generally be achieved by triggering the instrument's sweep if the duration of the sweep (with the analyzer configured as in Method SA-1, below) is equal to or shorter than the duration T of each transmission from the EUT and if those transmissions exhibit full power throughout their durations.

(ii) Method SA-2 or SA-2 Alternative (averaging across on and off times of the EUT transmissions, followed by duty cycle correction) shall be applied if the conditions of (i) cannot be achieved and the transmissions exhibit a constant duty cycle during the measurement duration. Duty cycle will be considered to be constant if variations are less than ± 2 percent.

(iii) Method SA-3 (RMS detection with max hold) or SA-3 Alternative (reduced VBW with max hold) shall be applied if the conditions of (i) and (ii) cannot be achieved.

b) Method SA-1 (trace averaging with the EUT transmitting at full power throughout each sweep): (i) Set span to encompass the entire emission bandwidth (EBW) (or, alternatively, the entire 99% occupied bandwidth) of the signal.

(ii) Set RBW = 1 MHz.

(iii) Set VBW ≥ 3 MHz.

(iv) Number of points in sweep ≥ 2 Span / RBW. (This ensures that bin-to-bin spacing is \leq RBW/2, so that narrowband signals are not lost between frequency bins.)

(v) Sweep time = auto.

(vi) Detector = RMS (i.e., power averaging), if available. Otherwise, use sample detector mode.

(vii) If transmit duty cycle < 98 percent, use a video trigger with the trigger level set to enable triggering only on full power pulses. Transmitter must operate at maximum power control level for the entire duration of every sweep. If the EUT transmits continuously (i.e., with no off intervals) or at duty cycle ≥ 98 percent, and if each transmission is entirely at the maximum power control level, then the trigger shall be set to "free run".

(viii) Trace average at least 100 traces in power averaging (i.e., RMS) mode.

(ix) Compute power by integrating the spectrum across the EBW (or, alternatively, the entire 99% occupied bandwidth) of the signal using the instrument's band power measurement function with band limits set equal to the EBW (or occupied bandwidth) band edges. If the instrument does not have a band power function, sum the spectrum

7.3 DEVIATION FROM STANDARD

No deviation.

7.4 TEST SETUP

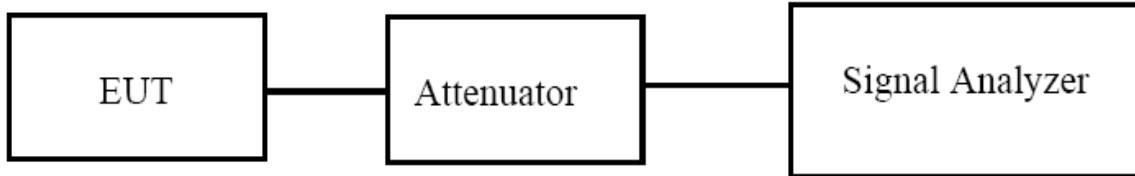

7.5 EUT OPERATION CONDITIONS

The EUT tested system was configured as the statements of 2.4 Unless otherwise a special operating condition is specified in the follows during the testing.

7.6 TEST RESULTS

EUT :	Wireless Digital Terminal	Model Name. :	S611
Temperature :	25 °C	Relative Humidity :	60%
Pressure :	1012 hPa	Test Voltage :	DC 3.85V
Test Mode :	TX (5G) Mode Frequency Band 1 (5150-5250MHz)		

Test Channel	Frequency	Maximum output power. Antenna port (AV)	LIMIT	Result
	(MHz)	(dBm)	dBm	
TX 802.11a Mode				
CH36	5180	10.3	23.98	Pass
CH40	5200	10.7	23.98	Pass
CH48	5240	11.5	23.98	Pass
TX 802.11 n20M Mode				
CH36	5180	9.9	23.98	Pass
CH40	5200	10.3	23.98	Pass
CH48	5240	11.2	23.98	Pass
TX 802.11 n40M Mode				
CH38	5190	9.3	23.98	Pass
CH46	5230	10.2	23.98	Pass
TX 802.11 ac20M Mode				
CH36	5180	10.1	23.98	Pass
CH40	5200	10.4	23.98	Pass
CH48	5240	11.3	23.98	Pass
TX 802.11 ac40M Mode				
CH38	5190	9.3	23.98	Pass
CH46	5230	10.2	23.98	Pass
TX 802.11 ac80M Mode				
CH42	5210	9.2	23.98	Pass

EUT :	Wireless Digital Terminal	Model Name. :	S611
Temperature :	25 °C	Relative Humidity :	60%
Pressure :	1012 hPa	Test Voltage :	DC 3.85V
Test Mode :	TX (5G) Mode Frequency Band 2A (5250-5350MHz)		

Test Channel	Frequency	Maximum output power. Antenna port (AV)	LIMIT	Result
	(MHz)	(dBm)	dBm	
TX 802.11a Mode				
CH52	5260	10.0	23.98	Pass
CH56	5280	10.5	23.98	Pass
CH64	5320	10.7	23.98	Pass
TX 802.11 n20M Mode				
CH52	5260	9.6	23.98	Pass
CH56	5280	10.1	23.98	Pass
CH64	5320	10.3	23.98	Pass
TX 802.11 n40M Mode				
CH54	5270	9.2	23.98	Pass
CH62	5310	9.5	23.98	Pass
TX 802.11 ac20M Mode				
CH52	5260	9.4	23.98	Pass
CH56	5280	9.8	23.98	Pass
CH64	5320	10.1	23.98	Pass
TX 802.11 ac40M Mode				
CH54	5270	8.9	23.98	Pass
CH62	5310	9.3	23.98	Pass
TX 802.11 ac80M Mode				
CH58	5290	8.7	23.98	Pass

EUT :	Wireless Digital Terminal	Model Name. :	S611
Temperature :	25 °C	Relative Humidity :	60%
Pressure :	1012 hPa	Test Voltage :	DC 3.85V
Test Mode :	TX (5G) Mode Frequency Band 2C (5470-5725MHz)		

Test Channel	Frequency	Maximum output power. Antenna port (AV)	LIMIT	Result
	(MHz)	(dBm)	dBm	
		Antenna A		
TX 802.11a Mode				
CH 100	5500	10.5	23.98	Pass
CH 120	5600	10.7	23.98	Pass
CH 140	5700	10.8	23.98	Pass
TX 802.11 n20M Mode				
CH 100	5500	10.0	23.98	Pass
CH 120	5600	10.1	23.98	Pass
CH 140	5700	10.3	23.98	Pass
TX 802.11 n40M Mode				
CH 102	5510	9.4	23.98	Pass
CH 118	5590	9.6	23.98	Pass
CH 134	5670	9.9	23.98	Pass
TX 802.11 ac20M Mode				
CH 100	5500	10.0	23.98	Pass
CH 120	5600	10.3	23.98	Pass
CH 140	5700	10.5	23.98	Pass
TX 802.11 ac40M Mode				
CH 102	5510	9.4	23.98	Pass
CH 118	5590	9.7	23.98	Pass
CH 134	5670	10.0	23.98	Pass
TX 802.11 ac80M Mode				
CH 106	5530	8.8	23.98	Pass
CH 122	5610	9.0	23.98	Pass

EUT :	Wireless Digital Terminal	Model Name. :	S611
Temperature :	25 °C	Relative Humidity :	60%
Pressure :	1012 hPa	Test Voltage :	DC 3.85V
Test Mode :	TX (5G) Mode Frequency Band 3 (5725-5850MHz)		

Test Channel	Frequency	Maximum output power. Antenna port (AV)	LIMIT	Result
	(MHz)	(dBm)	dBm	
TX 802.11a Mode				
CH149	5745	9.9	30.00	Pass
CH157	5785	9.8	30.00	Pass
CH165	5825	9.7	30.00	Pass
TX 802.11 n20M Mode				
CH149	5745	9.6	30.00	Pass
CH157	5785	9.4	30.00	Pass
CH165	5825	9.3	30.00	Pass
TX 802.11 n40M Mode				
CH151	5755	9.0	30.00	Pass
CH159	5795	8.9	30.00	Pass
TX 802.11 ac20M Mode				
CH149	5745	9.5	30.00	Pass
CH157	5785	9.4	30.00	Pass
CH165	5825	9.2	30.00	Pass
TX 802.11 ac40M Mode				
CH151	5755	8.9	30.00	Pass
CH159	5795	8.8	30.00	Pass
TX 802.11 ac80M Mode				
CH155	5775	8.4	30.00	Pass

8. OUT OF BAND EMISSIONS

8.1 APPLICABLE STANDARD

According to FCC §15.407(b)

Undesirable emission limits. Except as shown in paragraph (b)(7) of this section, the maximum emissions outside of the frequency bands of operation shall be attenuated in accordance with the following limits:

- (1) For transmitters operating in the 5.15-5.25 GHz band: All emissions outside of the 5.15-5.35 GHz band shall not exceed an e.i.r.p. of -27 dBm/MHz.
- (2) For transmitters operating in the 5.25-5.35 GHz band: All emissions outside of the 5.15-5.35 GHz band shall not exceed an e.i.r.p. of -27 dBm/MHz.
- (3) For transmitters operating in the 5.47-5.725 GHz band: All emissions outside of the 5.47-5.725 GHz band shall not exceed an e.i.r.p. of -27 dBm/MHz.
- (4) For transmitters operating in the 5.725-5.85 GHz band: All emissions within the frequency range from the band edge to 10 MHz above or below the band edge shall not exceed an e.i.r.p. of -17 dBm/MHz; for frequencies 10 MHz or greater above or below the band edge, emissions shall not exceed an e.i.r.p. of -27 dBm/MHz.

8.2 TEST PROCEDURE

1. Check the calibration of the measuring instrument using either an internal calibrator or a known signal from an external generator.
2. Position the EUT without connection to measurement instrument. Turn on the EUT and connect its antenna terminal to measurement instrument via a low loss cable. Then set it to any one measured frequency within its operating range, and make sure the instrument is operated in its linear range.
3. Set RBW of spectrum analyzer to 1 MHz with a convenient frequency span.
4. Measure the highest amplitude appearing on spectral display and set it as a reference level. Plot the graph with marking the highest point and edge frequency.
5. Repeat above procedures until all measured frequencies were complete.

8.3 DEVIATION FROM STANDARD

No deviation.

8.4 TEST SETUP

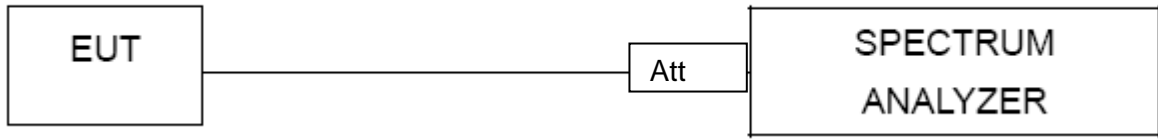

8.5 EUT OPERATION CONDITIONS

The EUT tested system was configured as the statements of 2.4 Unless otherwise a special operating condition is specified in the follows during the testing.

8.6 TEST RESULTS

EUT :	Wireless Digital Terminal	Model Name. :	S611
Temperature :	25 °C	Relative Humidity :	56%
Pressure :	1012 hPa	Test Voltage :	DC 3.85V

TX (5G) Mode Frequency Band 1/2A (5150-5350MHz)

5.15~5.35 GHz

(802.11a) Band Edge, Left Side

(802.11n20) Band Edge, Left Side

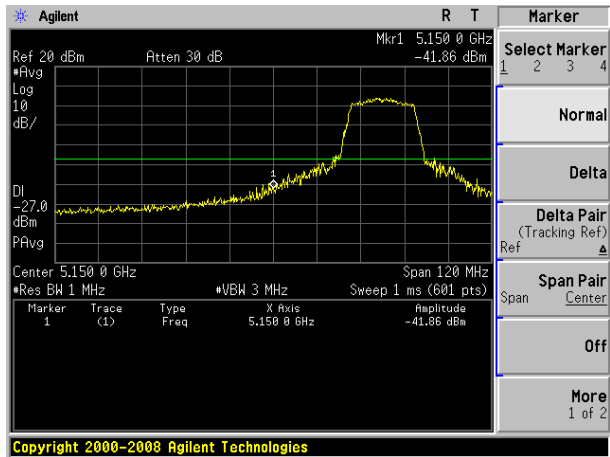
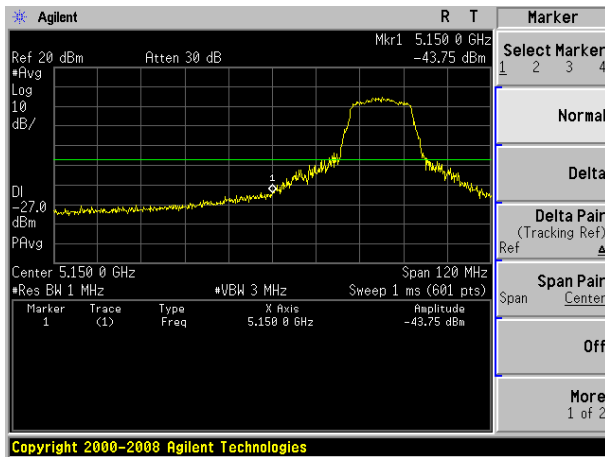

(802.11a) Band Edge, Right Side

(802.11n20) Band Edge, Right Side

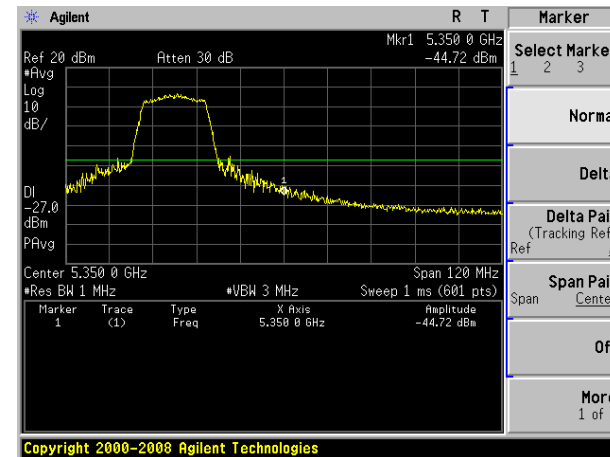
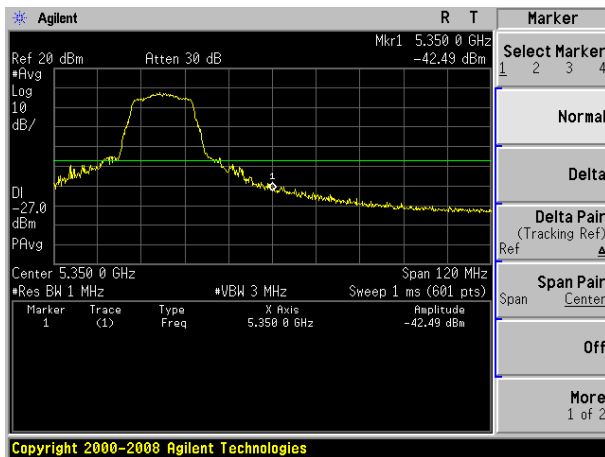

5.15~5.35 GHz

(802.11n40) Band Edge, Left Side

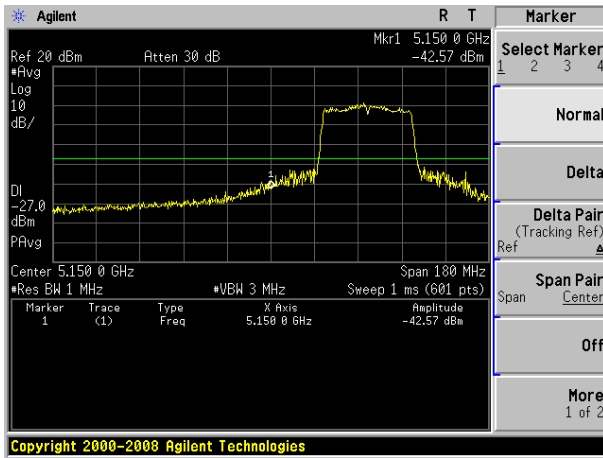

(802.11ac20) Band Edge, Left Side

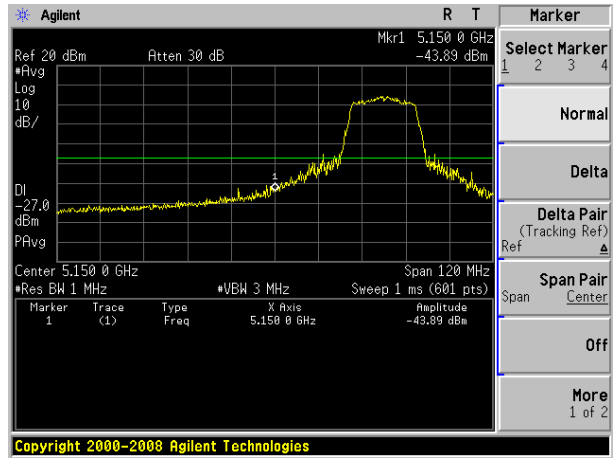

(802.11n40) Band Edge, Right Side

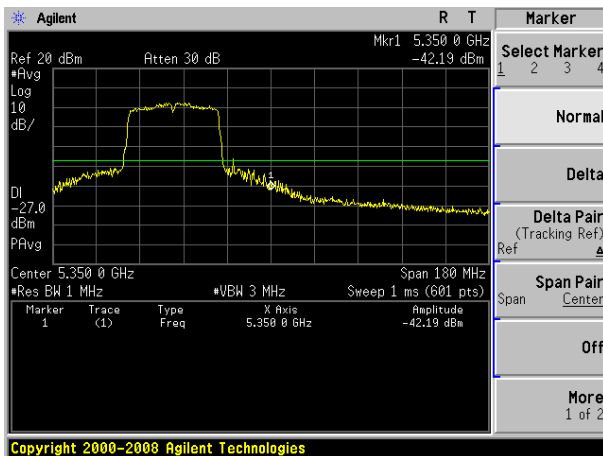

(802.11ac20) Band Edge, Right Side

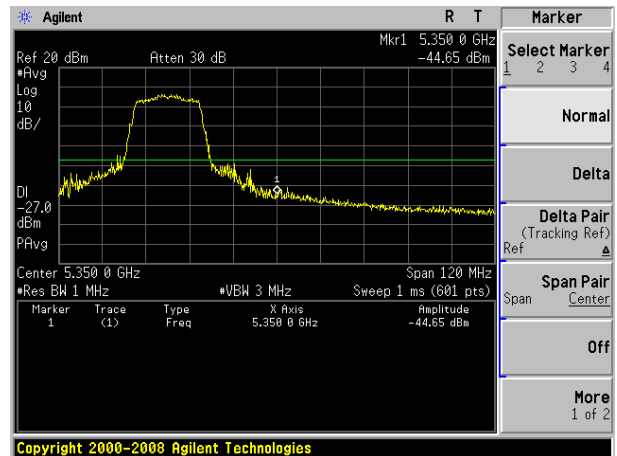

5.15~5.35 GHz

(802.11ac40) Band Edge, Left Side

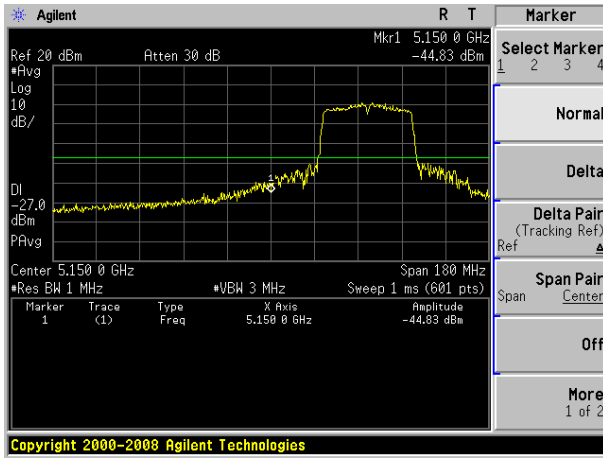

(802.11ac80) Band Edge, Left Side

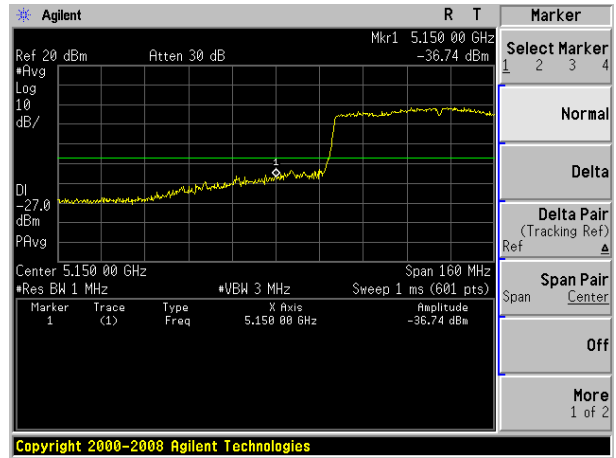

(802.11ac40) Band Edge, Right Side

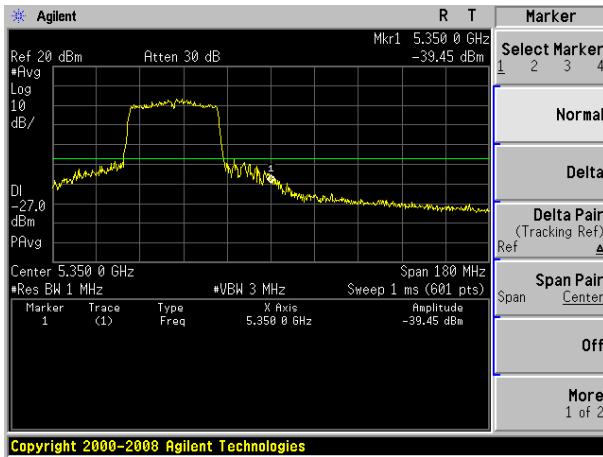

(802.11ac80) Band Edge, Right Side

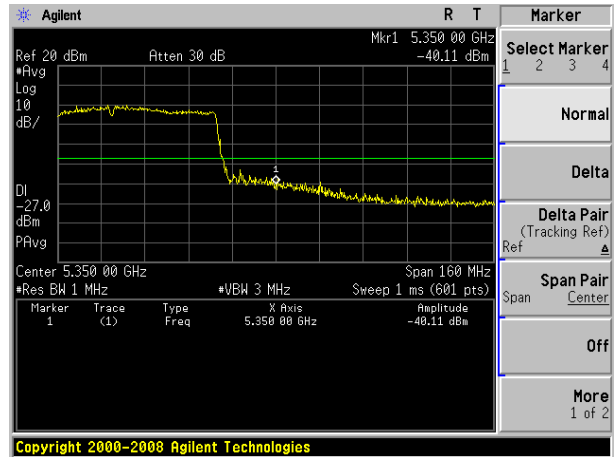

TX (5G) Mode Frequency Band 2C (5470-5725MHz)

5.47~5.725 GHz

(802.11a) Band Edge, Left Side

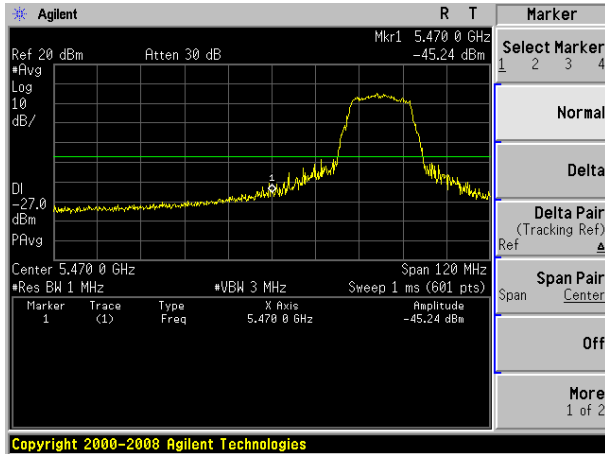

(802.11n20) Band Edge, Left Side

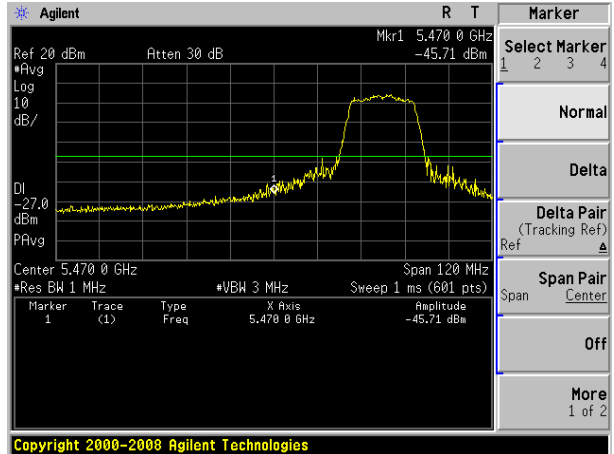

(802.11a) Band Edge, Right Side

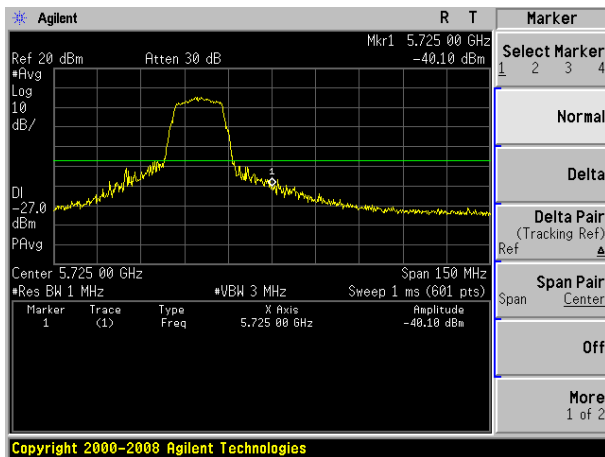

(802.11n20) Band Edge, Right Side

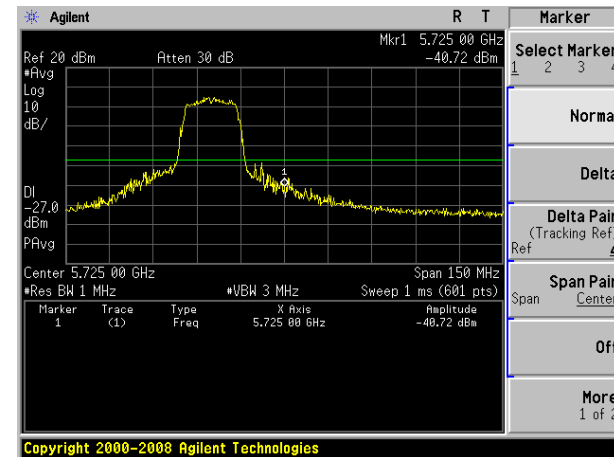

TX (5G) Mode Frequency Band 2C (5470-5725MHz)

5.47~5.725 GHz

(802.11n40) Band Edge, Left Side

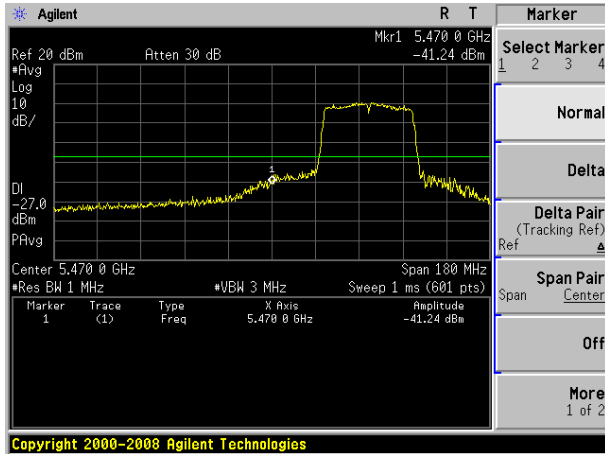

(802.11ac20) Band Edge, Left Side

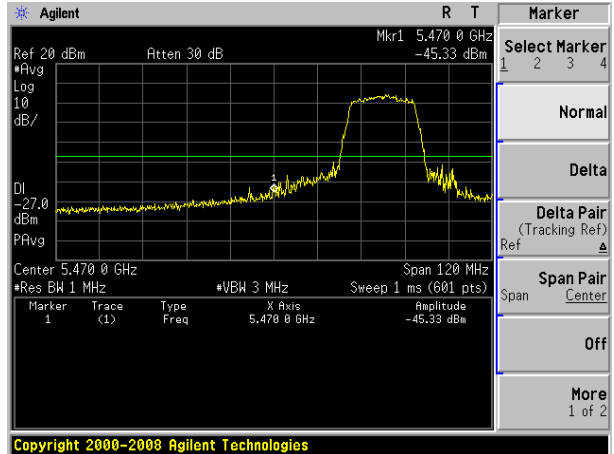

(802.11n40) Band Edge, Right Side

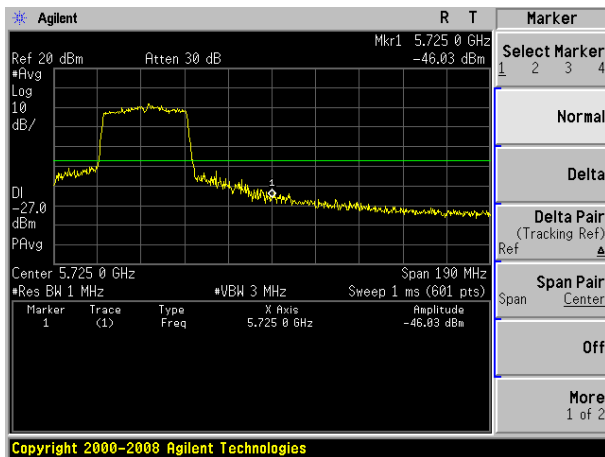

(802.11ac20) Band Edge, Right Side

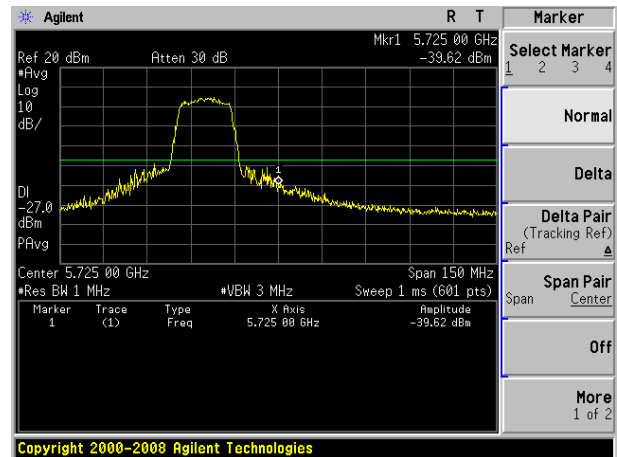

TX (5G) Mode Frequency Band 2C (5470-5725MHz)

5.47~5.725 GHz

(802.11ac40) Band Edge, Left Side

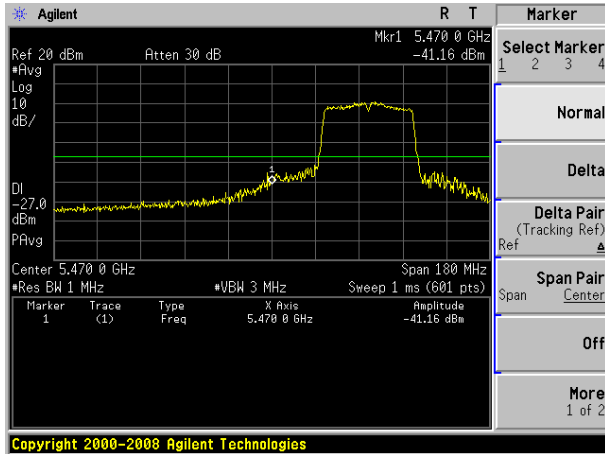

(802.11ac80) Band Edge, Left Side

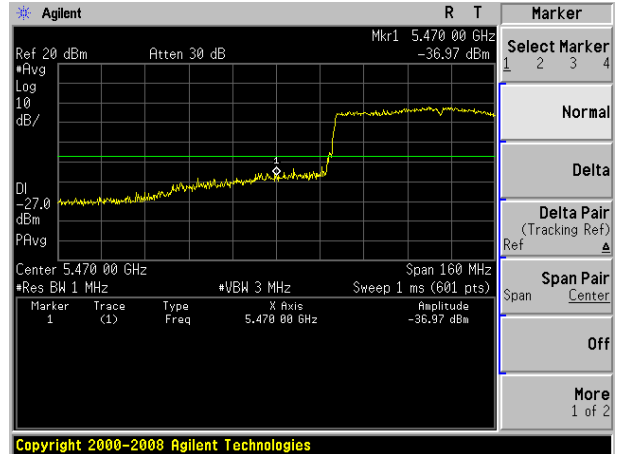

(802.11n40) Band Edge, Right Side

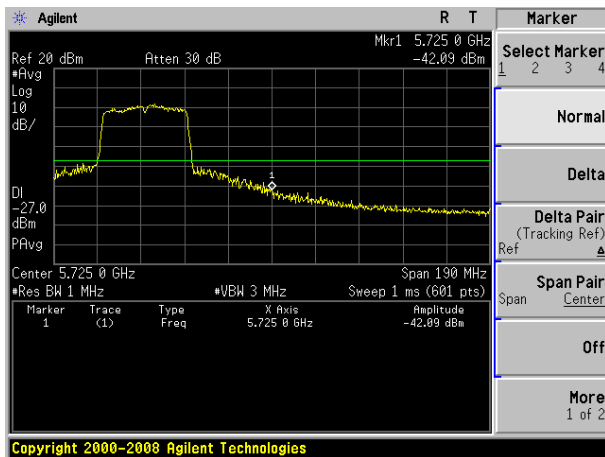

(802.11n80) Band Edge, Right Side

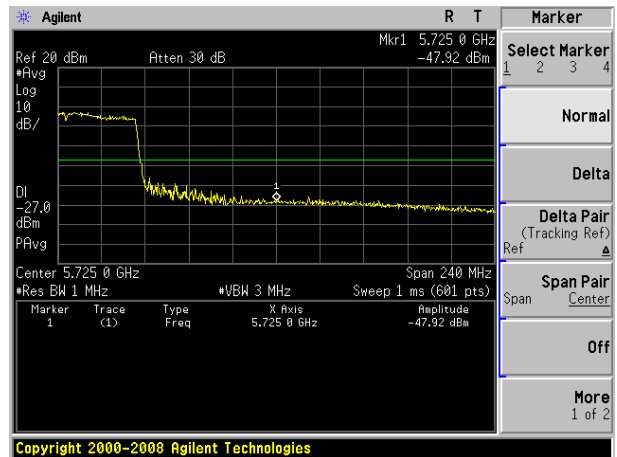

TX (5G) Mode Frequency Band 3 (5.725~5.850 GHz)

5.725~5.850 GHz

(802.11a) Band Edge, Left Side

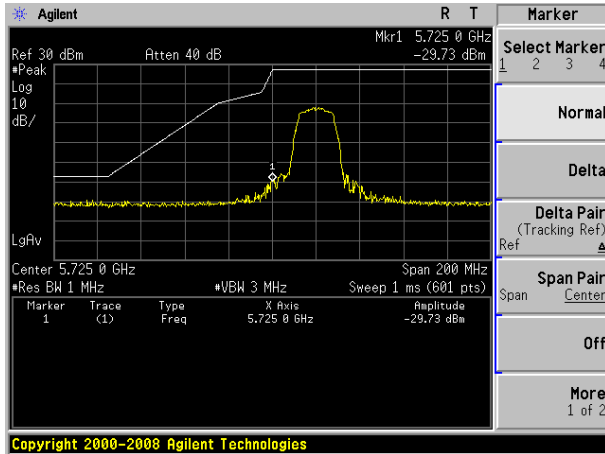

(802.11n20) Band Edge, Left Side

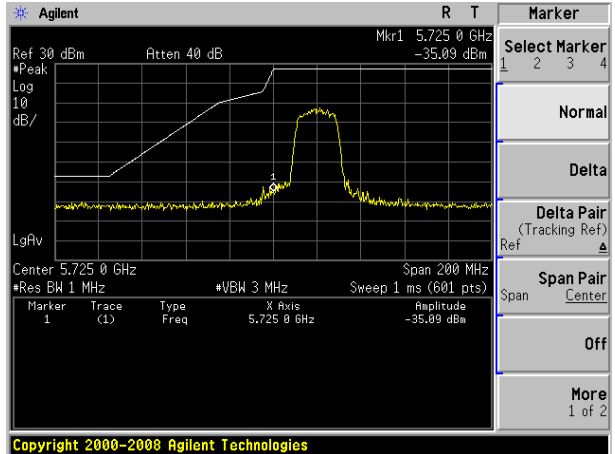

(802.11a) Band Edge, Right Side

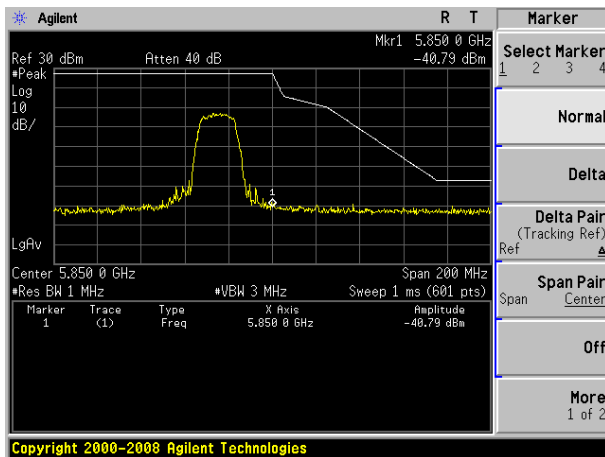

(802.11n20) Band Edge, Right Side

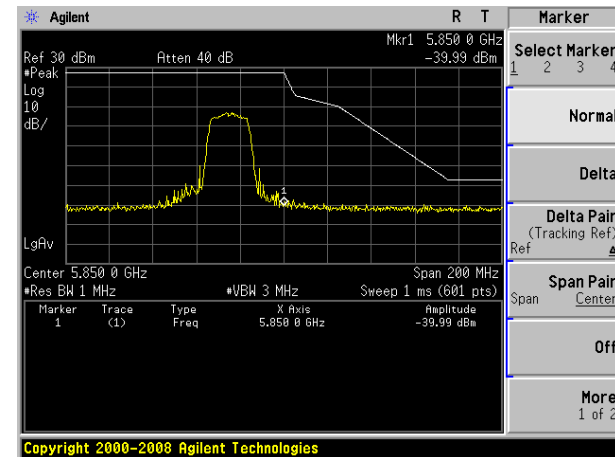

5.725~5.850 GHz

(802.11n40) Band Edge, Left Side

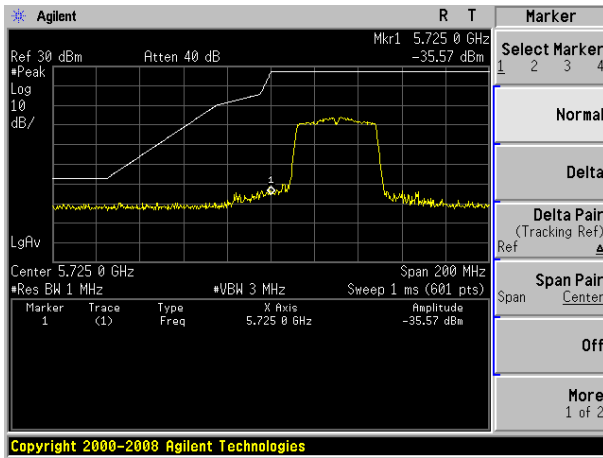

(802.11ac20) Band Edge, Left Side

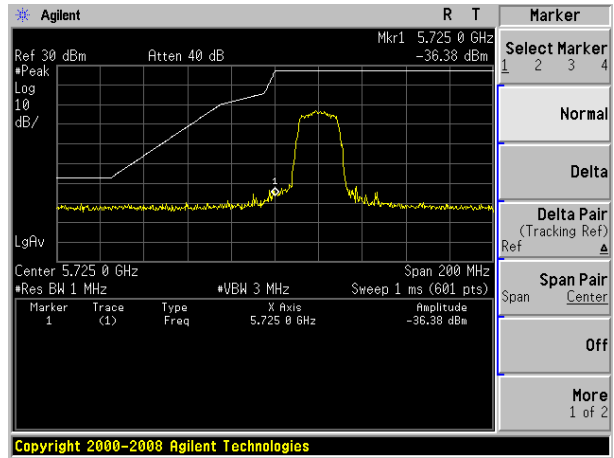

(802.11n40) Band Edge, Right Side

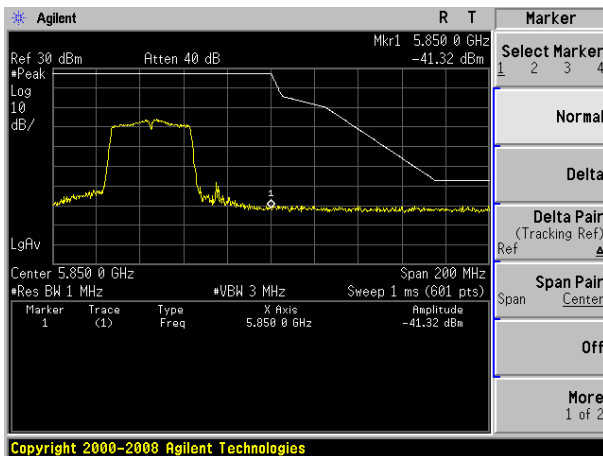

(802.11ac20) Band Edge, Right Side

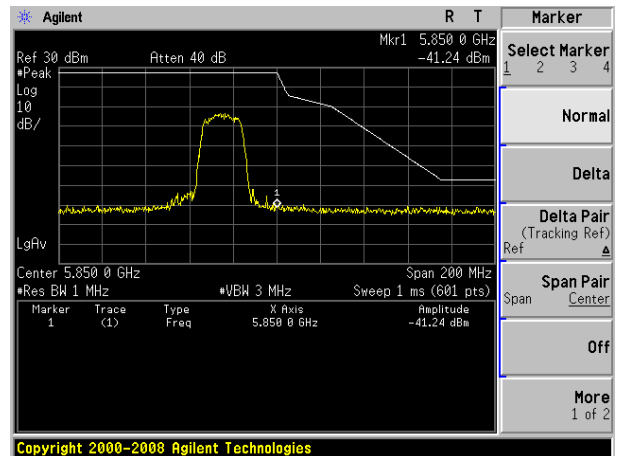

5.725~5.850 GHz

(802.11ac40) Band Edge, Left Side

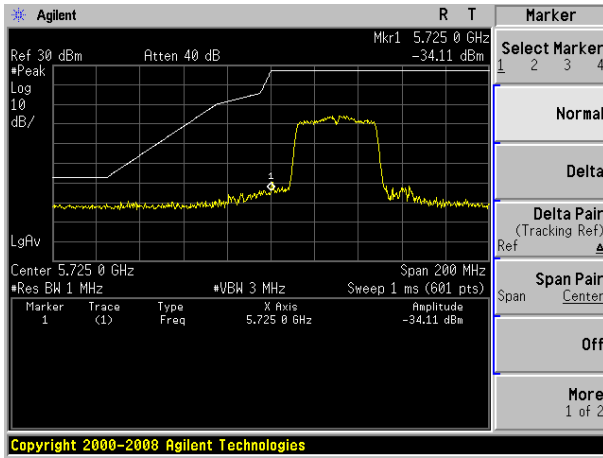

(802.11ac80) Band Edge, Left Side

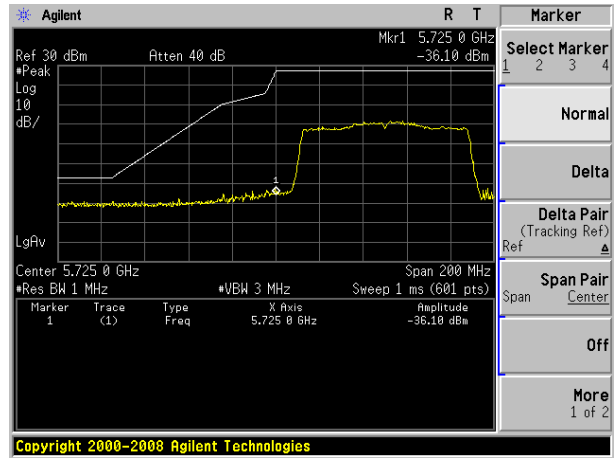

(802.11ac40) Band Edge, Right Side

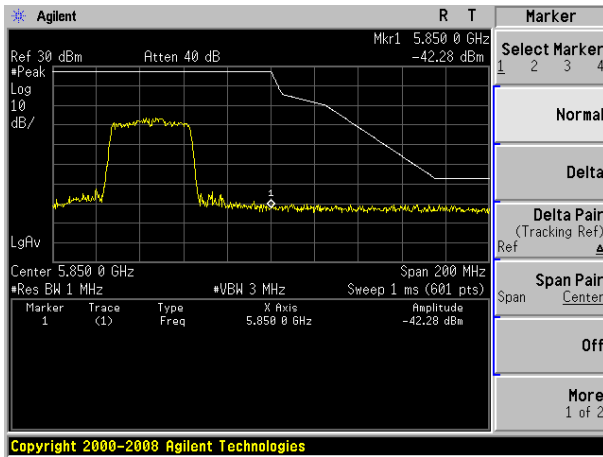

(802.11ac80) Band Edge, Right Side

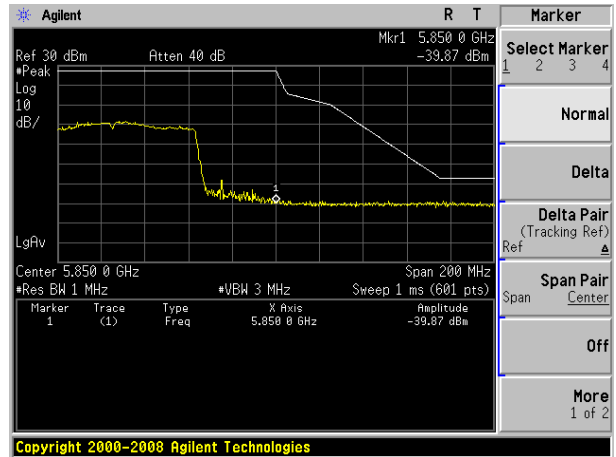

9.SPURIOUS RF CONDUCTED EMISSIONS

9.1 CONFORMANCE LIMIT

1. Below -20dB of the highest emission level in operating band.
2. Fall in the restricted bands listed in section 15.205. The maximum permitted average field strength is listed in section 15.209.

9.2 MEASURING INSTRUMENTS

The Measuring equipment is listed in the section 6.3 of this test report.

9.3 TEST SETUP

Please refer to Section 6.1 of this test report.

9.4 TEST PROCEDURE

The Spurious RF conducted emissions compliance of RF radiated emission should be measured by following 789033 D02 General U-NII Test Procedures New Rules v02r01, measuring the emission while the EUT is situated in three orthogonal planes (if appropriate), adjusting the measurement antenna height and polarization etc. Set RBW=1MHz and VBW= 3MHz to measure the peak field strength , and measure frequency range from 9KHz to 26.5GHz.

9.5 TEST RESULTS

Remark: The measurement frequency range is from 9KHz to the 10th harmonic of the fundamental frequency. The lowest, middle and highest channels are tested to verify the spurious emissions and bandedge measurement data.

TX (5G) Mode Frequency Band 1 (5150-5250MHz)

Test Plot

802.11a on channel 36

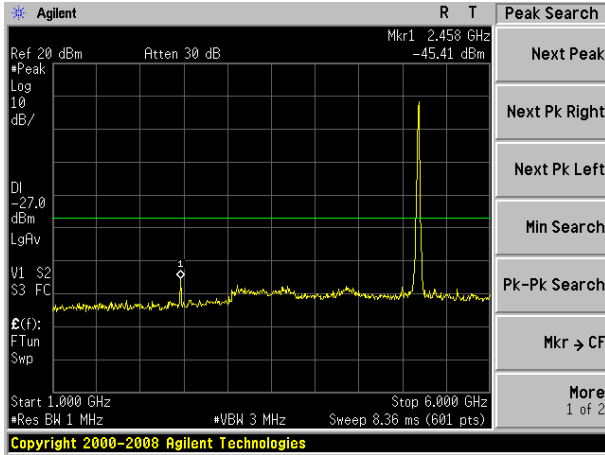

802.11n20 on channel 36

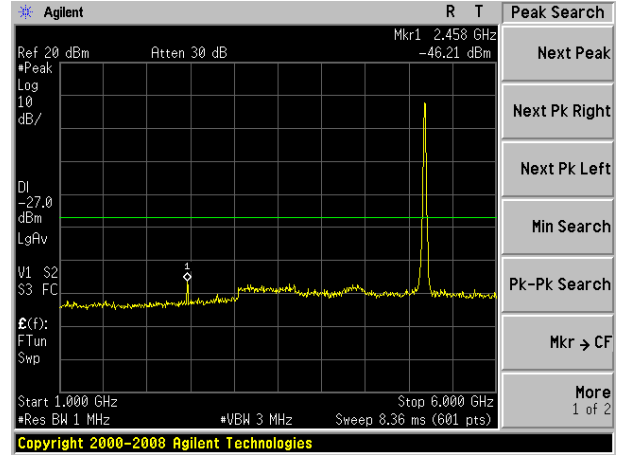

802.11a on channel 36

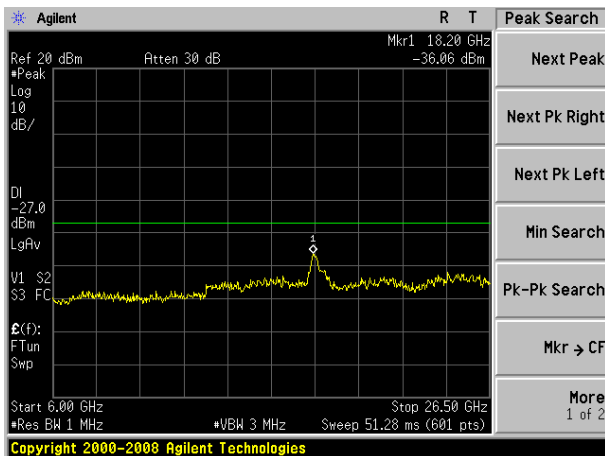

802.11n20 on channel 36

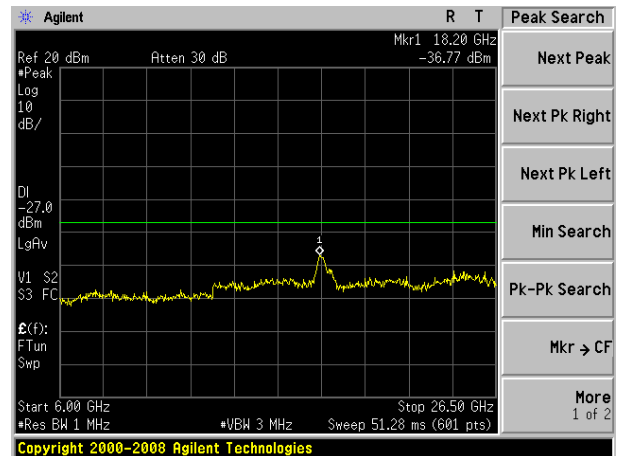

Note: Pre-test all modes and channels, only the worst data is recorded in the report

Test Plot

802.11n40 on channel 38

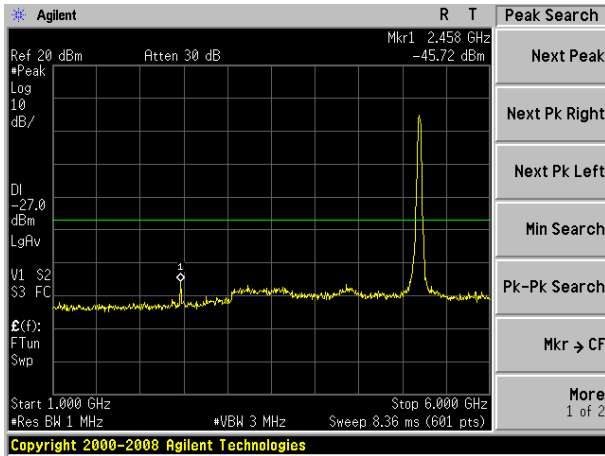

802.11ac20 on channel 36

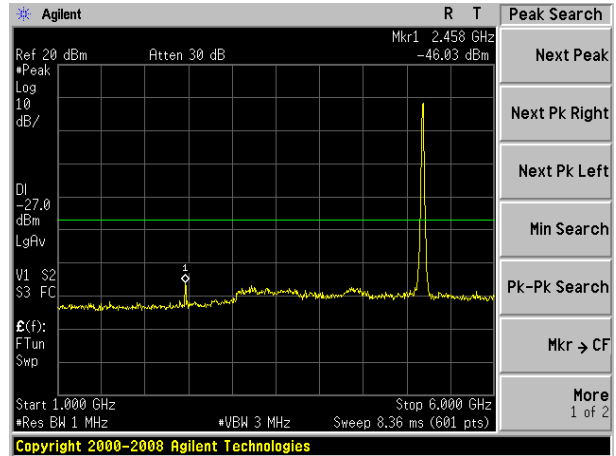

802.11n40 on channel 38

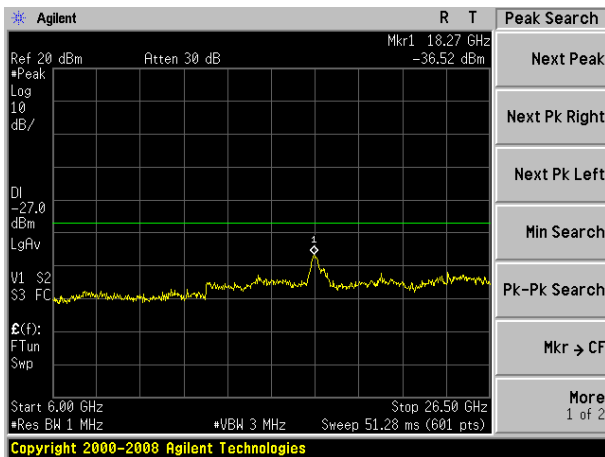

802.11ac20 on channel 36

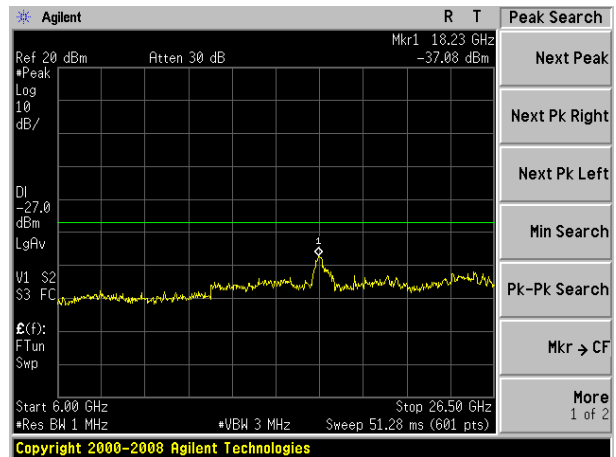

Note: Pre-test all modes and channels, only the worst data is recorded in the report

Test Plot

802.11ac40 on channel 38

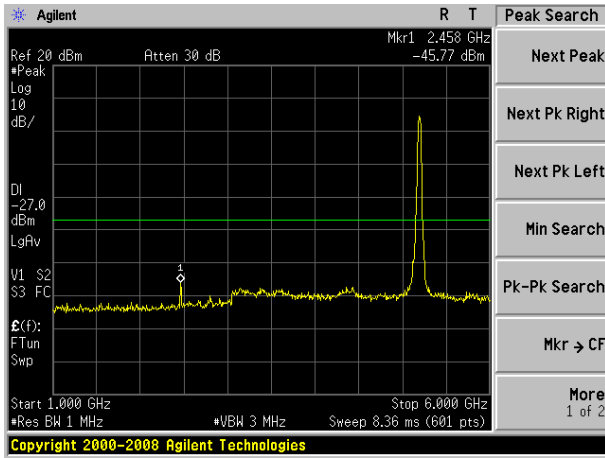

802.11ac80 on channel 42

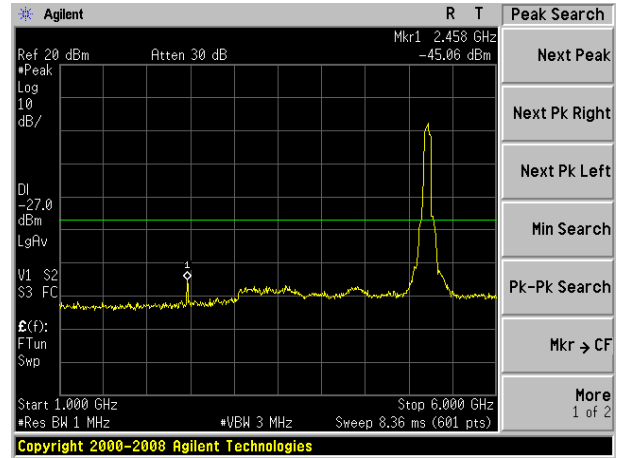

802.11ac40 on channel 38

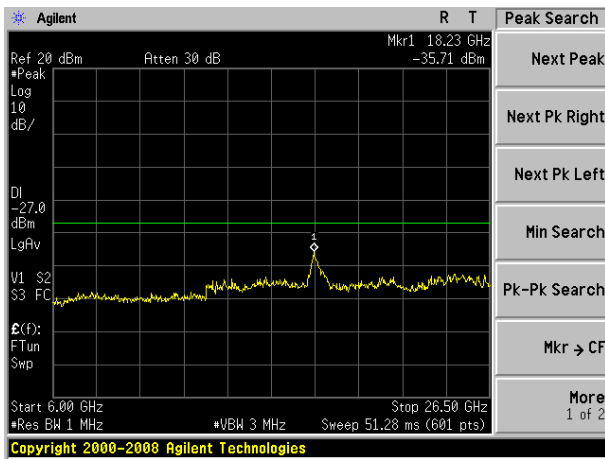

802.11ac80 on channel 42

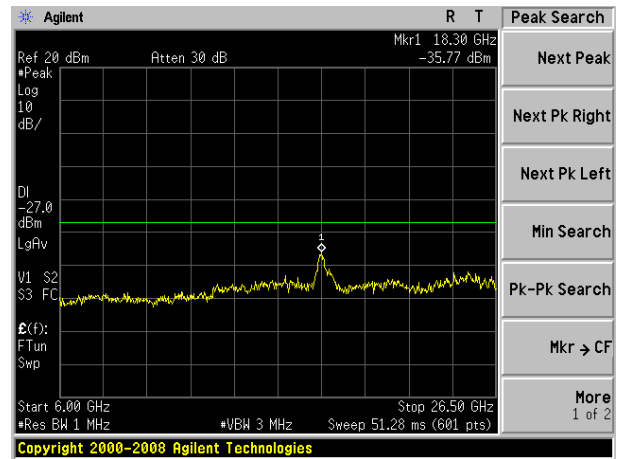

Note: Pre-test all modes and channels, only the worst data is recorded in the report

TX (5G) Mode Frequency Band 2A (5250-5350MHz)

Test Plot

802.11a on channel 52

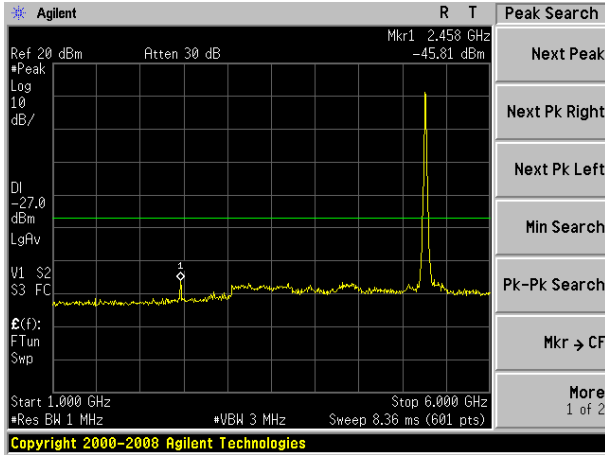

802.11n20 on channel 52

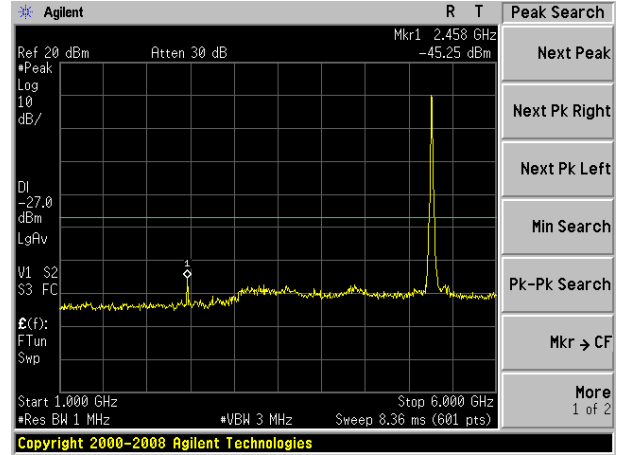

802.11a on channel 52

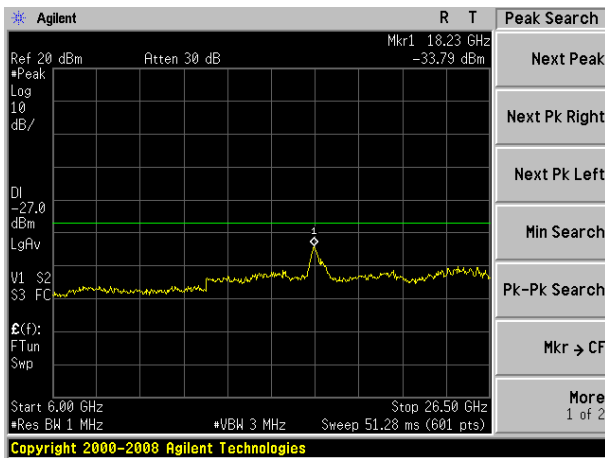

802.11n20 on channel 52

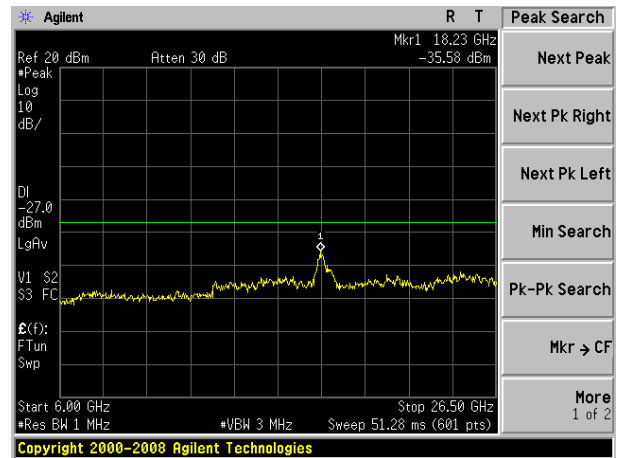

Note: Pre-test all modes and channels, only the worst data is recorded in the report

Test Plot

802.11n40 on channel 54

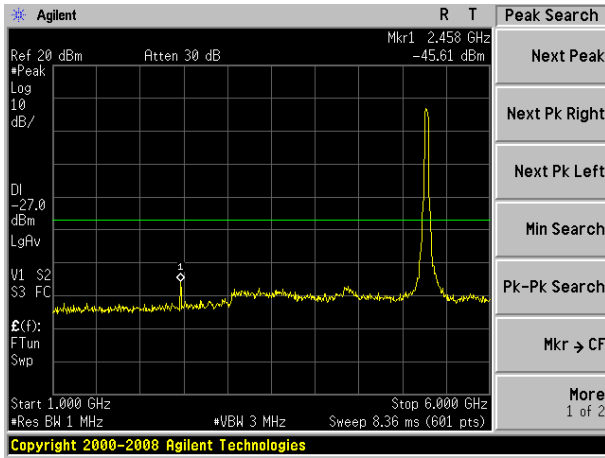

802.11ac20 on channel 52

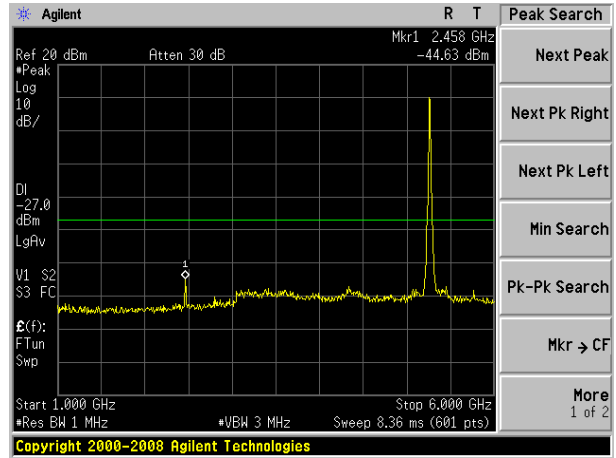

802.11n40 on channel 54

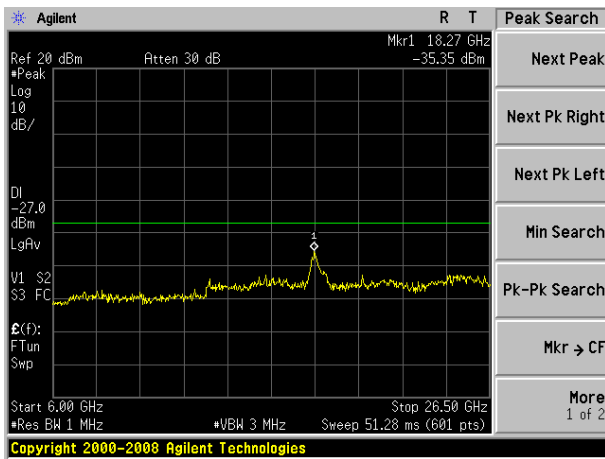

802.11ac20 on channel 52

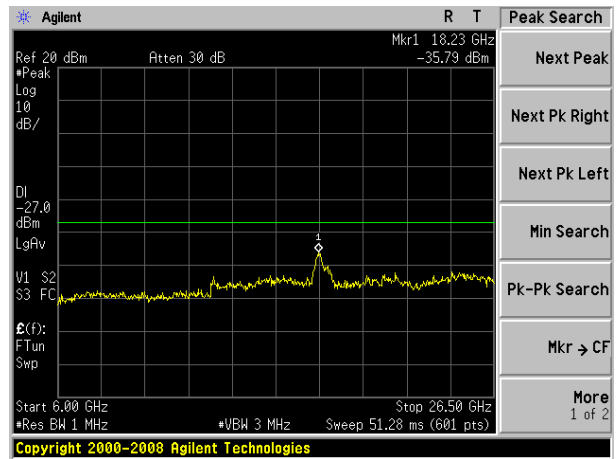

Note: Pre-test all modes and channels, only the worst data is recorded in the report

Test Plot

802.11ac40 on channel 54

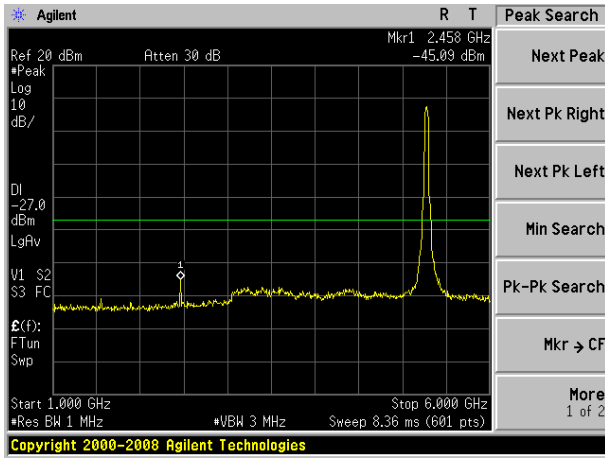

802.11ac80 on channel 58

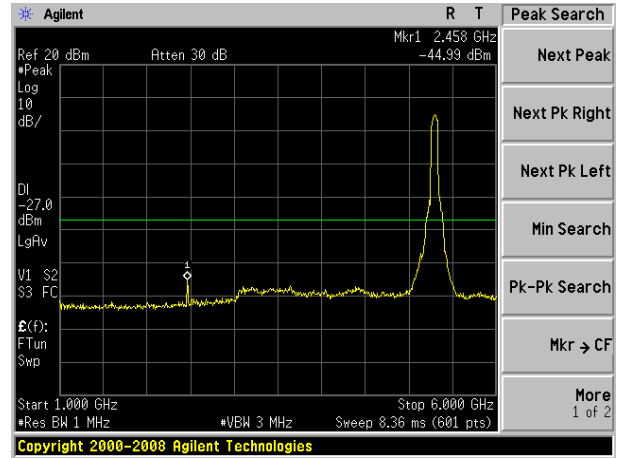

802.11ac40 on channel 54

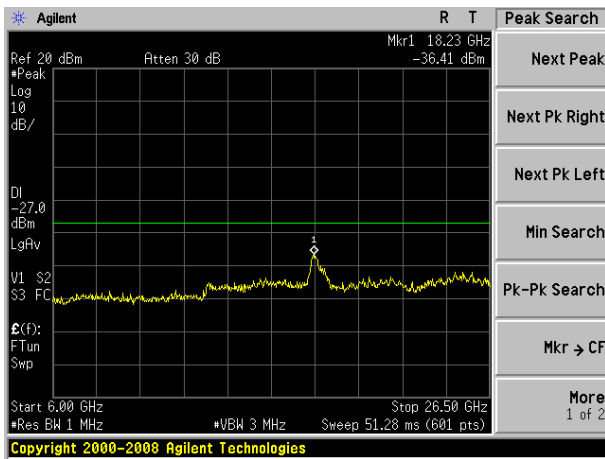

802.11ac80 on channel 58

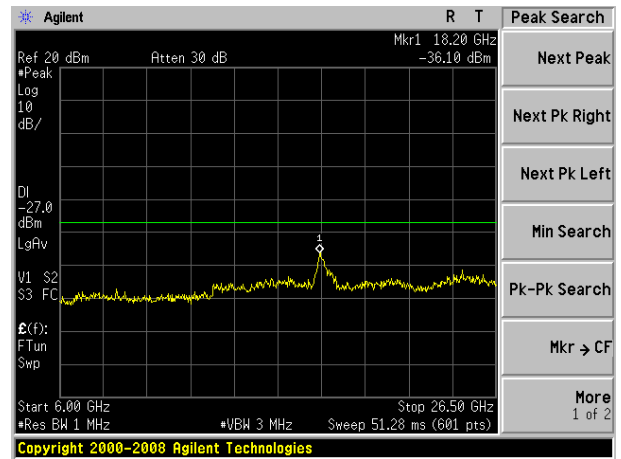

Note: Pre-test all modes and channels, only the worst data is recorded in the report

TX (5G) Mode Frequency Band 2C (5740-5725MHz)

Test Plot

802.11a on channel 120

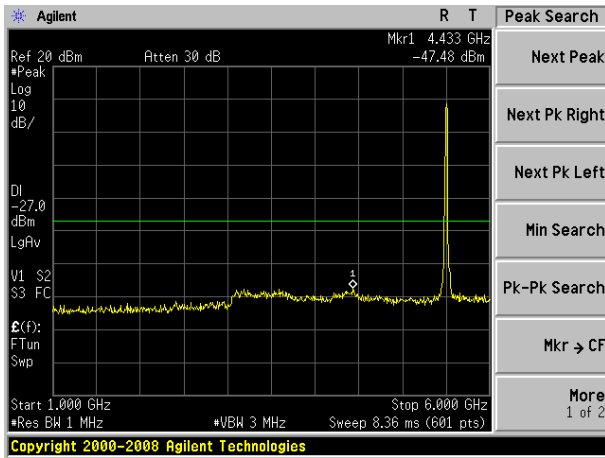

802.11n20 on channel 120

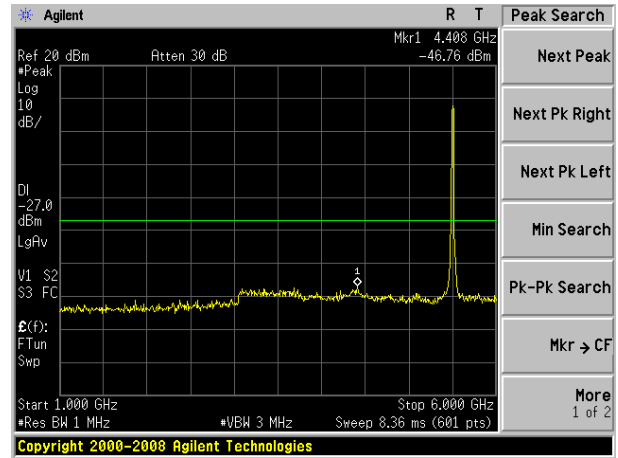

802.11a on channel 120

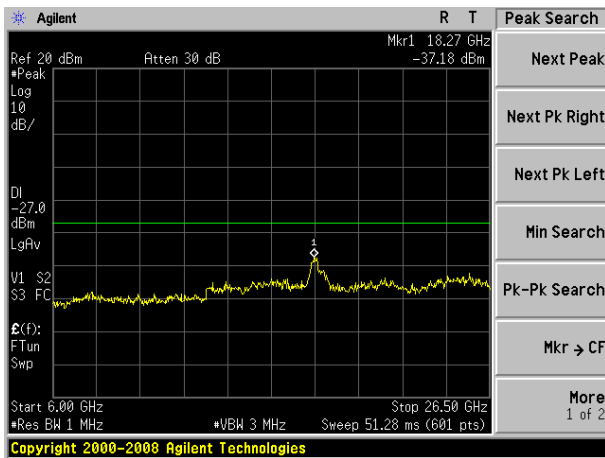

802.11n20 on channel 120

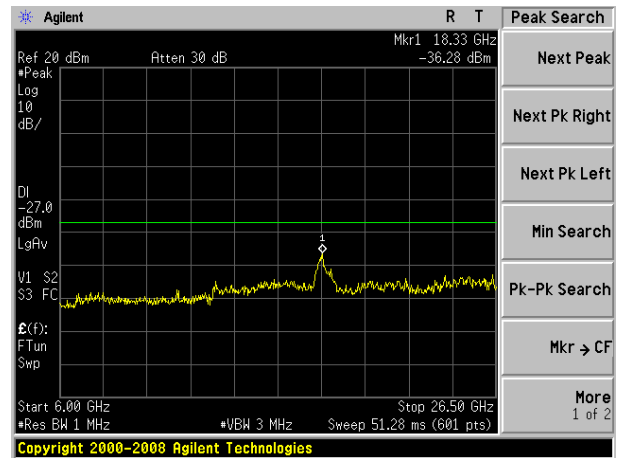

Note: Pre-test all modes and channels, only the worst data is recorded in the report

Test Plot

802.11n40 on channel 118

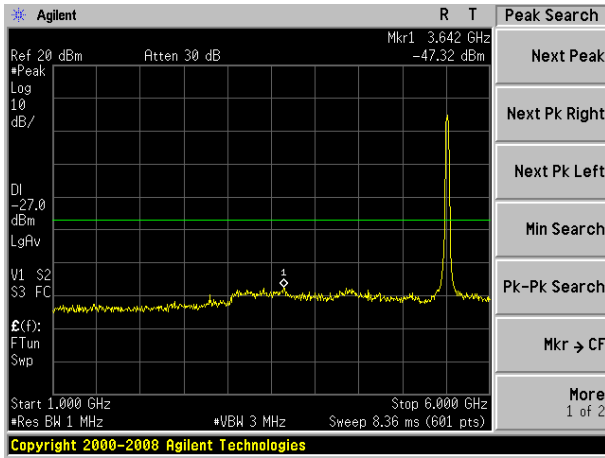

802.11ac20 on channel 120

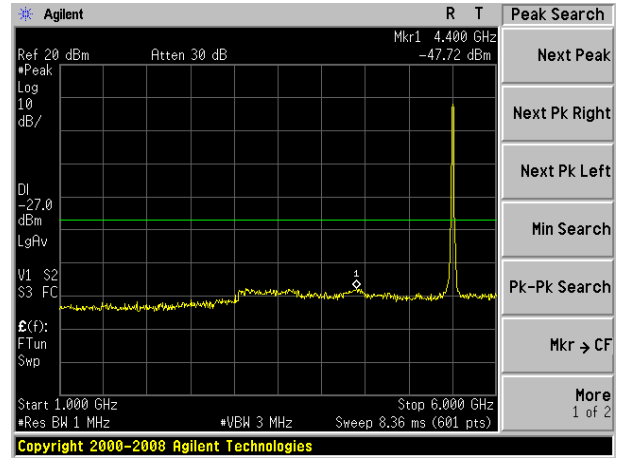

802.11n40 on channel 118

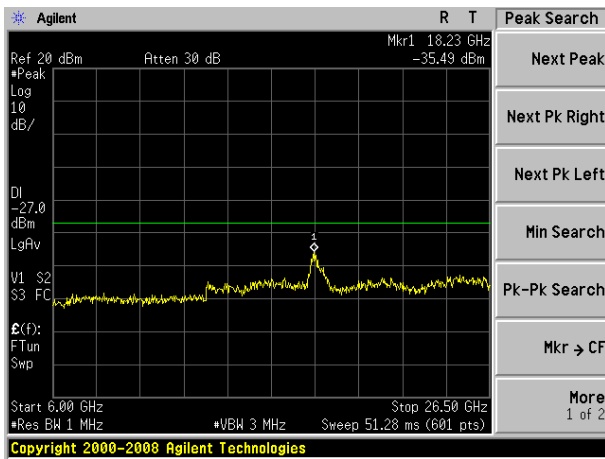

802.11ac20 on channel 120

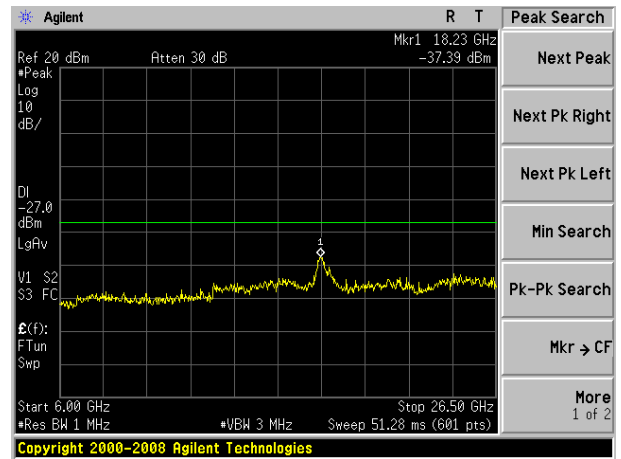

Note: Pre-test all modes and channels, only the worst data is recorded in the report

Test Plot

802.11ac40 on channel 118

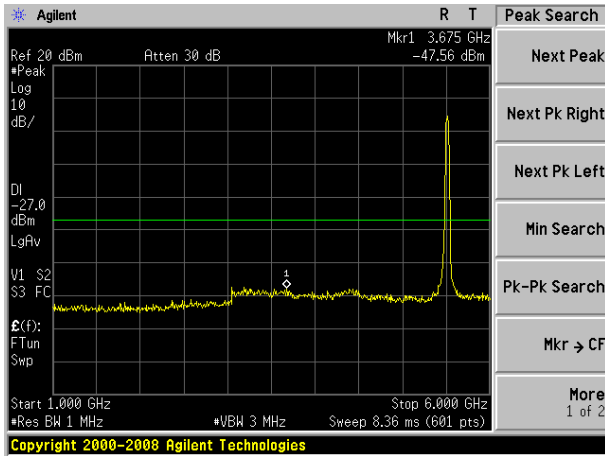

802.11ac80 on channel 106

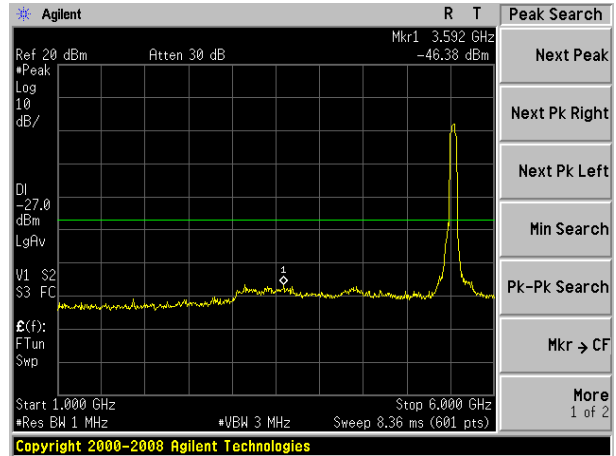

802.11ac40 on channel 118

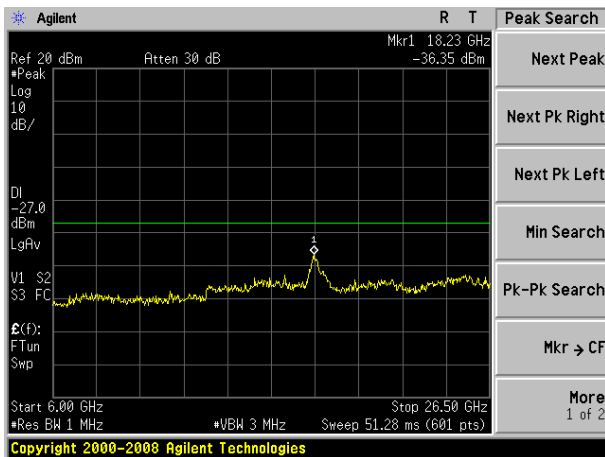

802.11ac80 on channel 106

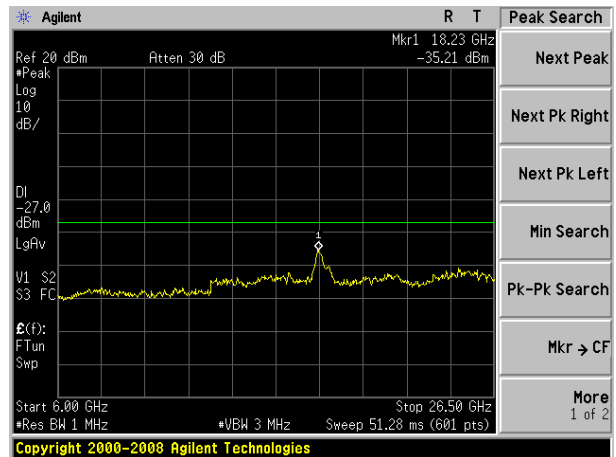

Note: Pre-test all modes and channels, only the worst data is recorded in the report

Test Plot

802.11ac80 on channel 122

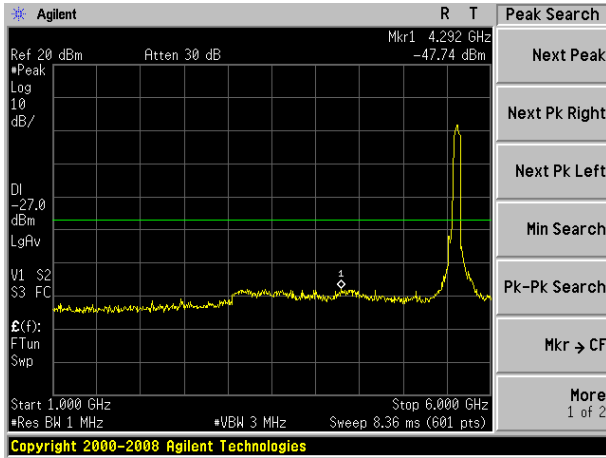

802.11ac80 on channel 122

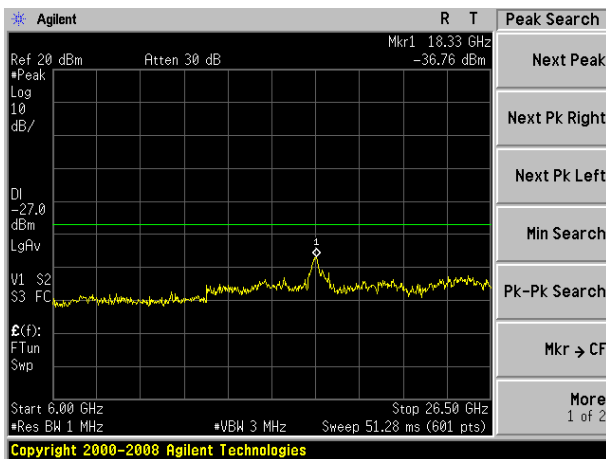

Note: Pre-test all modes and channels, only the worst data is recorded in the report

TX (5G) Mode Frequency Band 3 (5725-5850MHz)

Test Plot

802.11a on channel 149

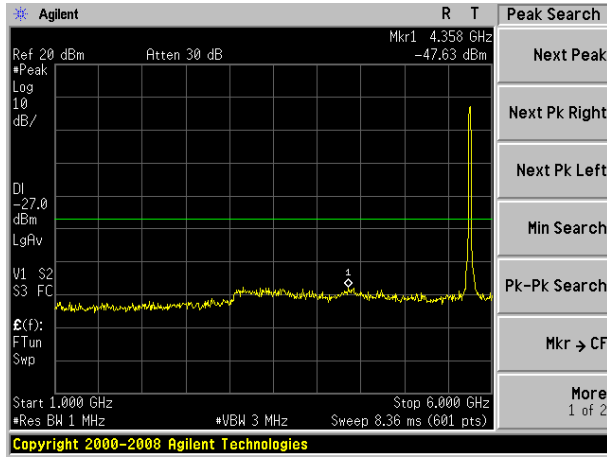

802.11n20 on channel 149

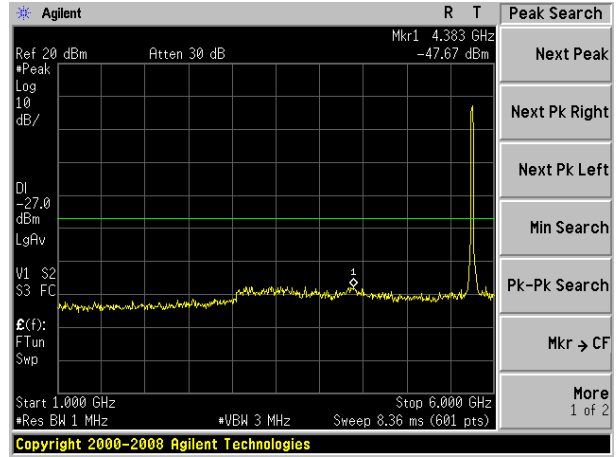

802.11a on channel 149

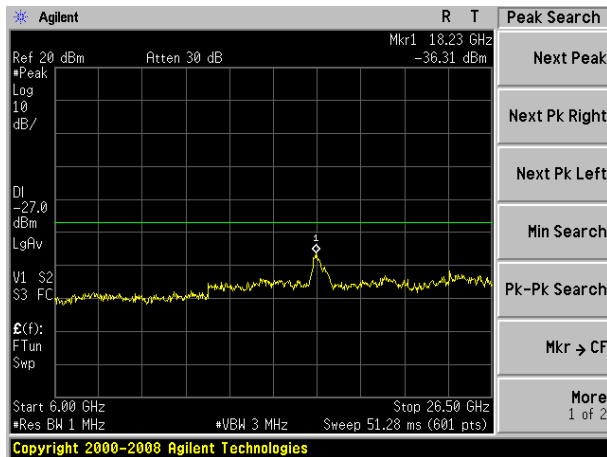

802.11n20 on channel 149

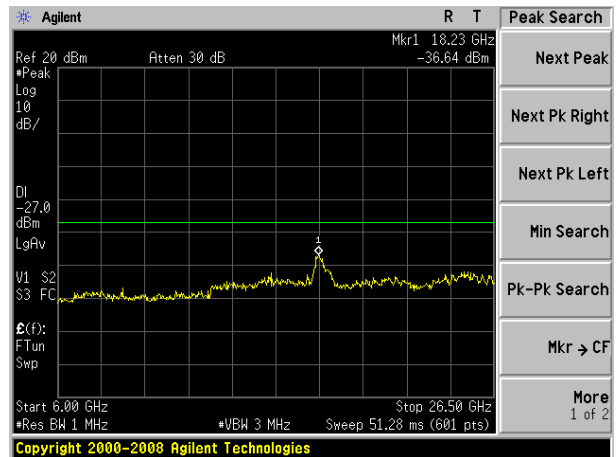

Note: Pre-test all modes and channels, only the worst data is recorded in the report

Test Plot

802.11n40 on channel 151

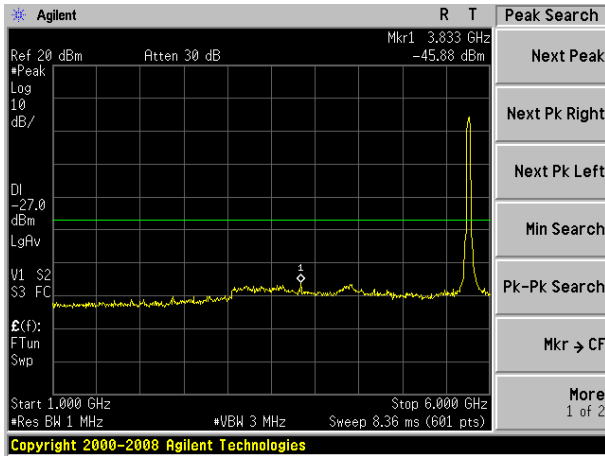

802.11ac20 on channel 149

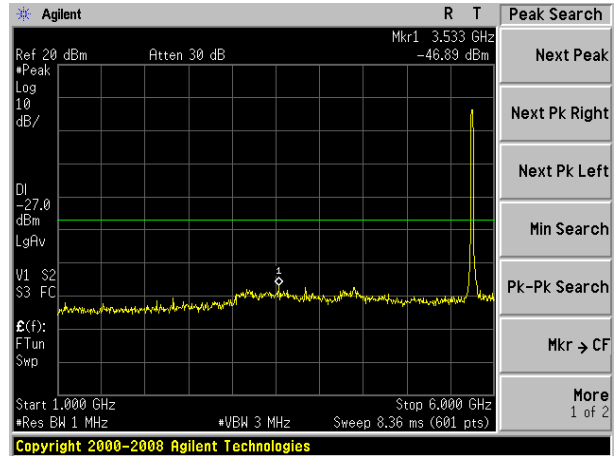

802.11n40 on channel 151

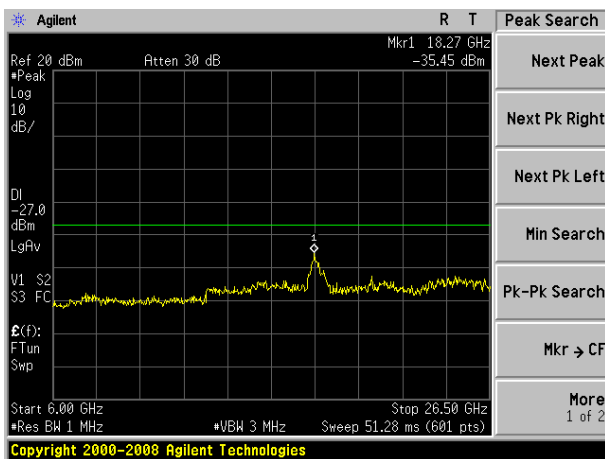

802.11ac20 on channel 149

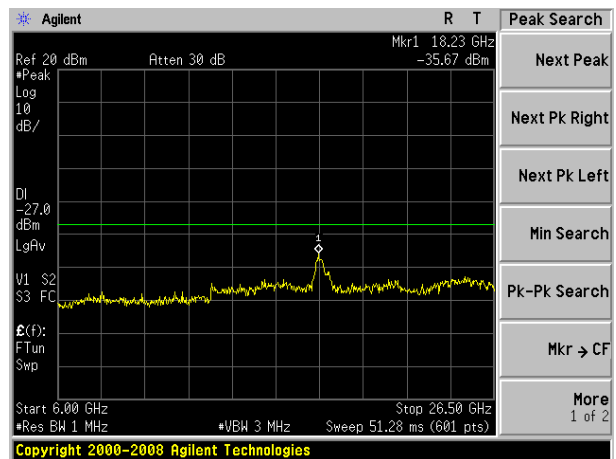

Note: Pre-test all modes and channels, only the worst data is recorded in the report

Test Plot

802.11ac40 on channel 151

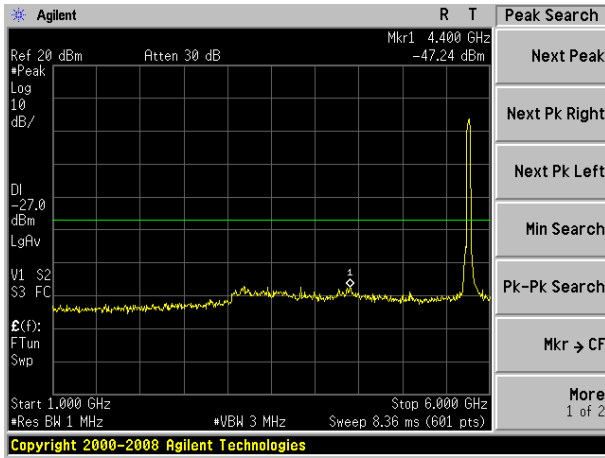

802.11ac80 on channel 155

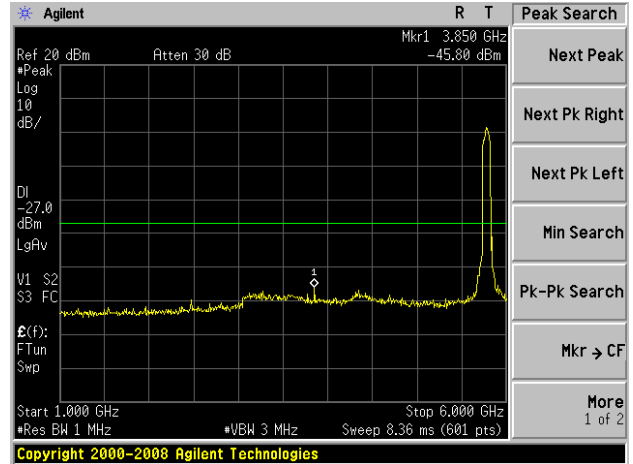

802.11ac40 on channel 151

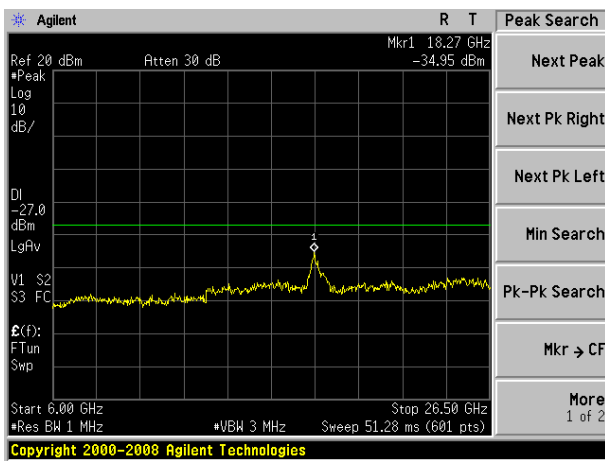

802.11ac80 on channel 155

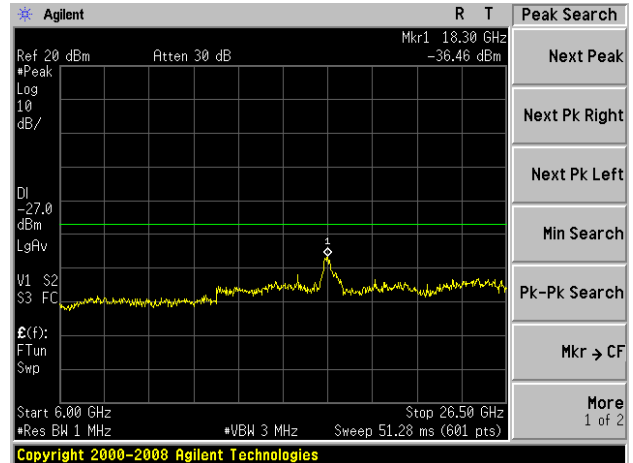

Note: Pre-test all modes and channels, only the worst data is recorded in the report

10. FREQUENCY STABILITY MEASUREMENT

10.1 LIMIT

Manufactures of U-NII devices are responsible for ensuring frequency stability such that an emission is maintained within the band of operation under all conditions of normal operation as specified in the user's manual.

The transmitter center frequency tolerance shall be ± 20 ppm maximum for the 5 GHz band (IEEE 802.11n specification).

10.2 TEST PROCEDURES

1. The transmitter output (antenna port) was connected to the spectrum analyzer.
2. EUT have transmitted absence of modulation signal and fixed channelize.
3. Set the spectrum analyzer span to view the entire absence of modulation emissions bandwidth.
4. Set RBW = 10 kHz, VBW = 10 kHz with peak detector and maxhold settings.
5. f_c is declaring of channel frequency. Then the frequency error formula is $(f_c - f) / f_c \times 10^6$ ppm and the limit is less than ± 20 ppm (IEEE 802.11n specification).
6. The test extreme voltage is to change the primary supply voltage from 85 to 115 percent of the nominal value
7. Extreme temperature is $-20^\circ\text{C} \sim 70^\circ\text{C}$.

10.3 TEST SETUP LAYOUT

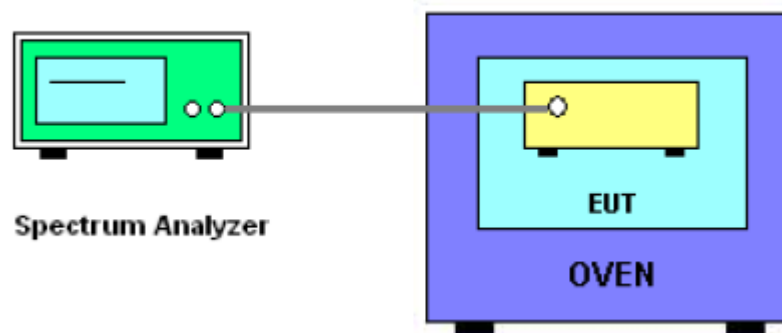

10.4 EUT OPERATION DURING TEST

The EUT was programmed to be in continuously un-modulation transmitting mode.

10.5 TEST RESULTS

EUT :	Wireless Digital Terminal	Model Name. :	S611
Temperature :	25 °C	Relative Humidity :	56%
Pressure :	1012 hPa	Test Voltage :	DC 3.85V
Test Mode :	TX Frequency Band I (5150-5250MHz)		

Voltage vs. Frequency Stability

TEST CONDITIONS				Reference Frequency: 5180MHz			
				f	fc	Max. Deviation (MHz)	Max. Deviation (ppm)
T nom (°C)	20	V nom (V)	3.85	5180.0223	5180	0.0223	-4.3050
		V max (V)	4.43	5180.0141	5180	0.0141	-2.7220
		V min (V)	3.27	5180.0112	5180	0.0112	-2.1622
Limits				± 20 ppm			
Result				Complies			

Temperature vs. Frequency Stability

TEST CONDITIONS				Reference Frequency: 5180MHz			
				f	fc	Max. Deviation (MHz)	Max. Deviation (ppm)
V nom (V)	3.85	T (°C)	-20	5180.0111	5180	0.0111	-2.1429
		T (°C)	-10	5180.0115	5180	0.0115	-2.2201
		T (°C)	0	5180.0253	5180	0.0253	-4.8842
		T (°C)	10	5180.0136	5180	0.0136	-2.6255
		T (°C)	20	5180.0120	5180	0.0120	-2.3166
		T (°C)	30	5180.0134	5180	0.0134	-2.5869
		T (°C)	40	5180.0117	5180	0.0117	-2.2587
		T (°C)	50	5180.0143	5180	0.0143	-2.7606
		T (°C)	60	5180.0161	5180	0.0161	-3.1081
		T (°C)	70	5180.0117	5180	0.0117	-2.2587
Limits				± 20 ppm			
Result				Complies			

Voltage vs. Frequency Stability

TEST CONDITIONS				Reference Frequency: 5200MHz			
				f	fc	Max. Deviation (MHz)	Max. Deviation (ppm)
T nom (°C)	20	V nom (V)	3.85	5200.0157	5200	0.0157	-3.0192
		V max (V)	4.43	5200.0115	5200	0.0115	-2.2115
		V min (V)	3.27	5200.0133	5200	0.0133	-2.5577
Limits				± 20 ppm			
Result				Complies			

Temperature vs. Frequency Stability

TEST CONDITIONS				Reference Frequency: 5200MHz			
				f	fc	Max. Deviation (MHz)	Max. Deviation (ppm)
V nom (V)	3.85	T (°C)	-20	5200.0312	5200	0.0312	-6.0000
		T (°C)	-10	5200.0124	5200	0.0124	-2.3846
		T (°C)	0	5200.0312	5200	0.0312	-6.0000
		T (°C)	10	5200.0207	5200	0.0207	-3.9808
		T (°C)	20	5200.0135	5200	0.0135	-2.5962
		T (°C)	30	5200.0122	5200	0.0122	-2.3462
		T (°C)	40	5200.0181	5200	0.0181	-3.4808
		T (°C)	50	5200.0173	5200	0.0173	-3.3269
		T (°C)	60	5200.0130	5200	0.0130	-2.5000
		T (°C)	70	5200.0123	5200	0.0123	-2.3654
Limits				± 20 ppm			
Result				Complies			

Voltage vs. Frequency Stability

TEST CONDITIONS				Reference Frequency: 5240MHz			
				f	fc	Max. Deviation (MHz)	Max. Deviation (ppm)
T nom (°C)	20	V nom (V)	3.85	5240.0117	5240	0.0117	-2.2328
		V max (V)	4.43	5240.0174	5240	0.0174	-3.3206
		V min (V)	3.27	5240.0157	5240	0.0157	-2.9962
Limits				± 20 ppm			
Result				Complies			

Temperature vs. Frequency Stability

TEST CONDITIONS				Reference Frequency: 5240MHz			
				f	fc	Max. Deviation (MHz)	Max. Deviation (ppm)
V nom (V)	3.85	T (°C)	-20	5240.0114	5240	0.0114	-2.1756
		T (°C)	-10	5240.0156	5240	0.0156	-2.9771
		T (°C)	0	5240.0154	5240	0.0154	-2.9389
		T (°C)	10	5240.0229	5240	0.0229	-4.3702
		T (°C)	20	5240.0125	5240	0.0125	-2.3855
		T (°C)	30	5240.0147	5240	0.0147	-2.8053
		T (°C)	40	5240.0177	5240	0.0177	-3.3779
		T (°C)	50	5240.0165	5240	0.0165	-3.1489
		T (°C)	60	5240.0127	5240	0.0127	-2.4237
		T (°C)	70	5240.0111	5240	0.0111	-2.1183
Limits				± 20 ppm			
Result				Complies			

EUT :	Wireless Digital Terminal	Model Name. :	S611
Temperature :	25 °C	Relative Humidity :	56%
Pressure :	1012 hPa	Test Voltage :	DC 3.85V
Test Mode :	TX Frequency Band 2A (5250-5350MHz)		

Voltage vs. Frequency Stability

TEST CONDITIONS				Reference Frequency: 5260MHz			
				f	fc	Max. Deviation (MHz)	Max. Deviation (ppm)
T nom (°C)	20	V nom (V)	3.85	5260.01590	5260	0.01590	-3.0228
		V max (V)	4.43	5260.01410	5260	0.01410	-2.6806
		V min (V)	3.27	5260.01950	5260	0.01950	-3.7072
Limits				± 20 ppm			
Result				Complies			

Temperature vs. Frequency Stability

TEST CONDITIONS				Reference Frequency: 5260MHz			
				f	fc	Max. Deviation (MHz)	Max. Deviation (ppm)
V nom (V)	3.85	T (°C)	-20	5260.00520	5260	0.00520	-0.9886
		T (°C)	-10	5260.02280	5260	0.02280	-4.3346
		T (°C)	0	5260.00650	5260	0.00650	-1.2357
		T (°C)	10	5260.01460	5260	0.01460	-2.7757
		T (°C)	20	5260.00590	5260	0.00590	-1.1217
		T (°C)	30	5260.00790	5260	0.00790	-1.5019
		T (°C)	40	5260.01440	5260	0.01440	-2.7376
		T (°C)	50	5260.00620	5260	0.00620	-1.1787
		T (°C)	60	5260.02250	5260	0.02250	-4.2776
		T (°C)	70	5260.02090	5260	0.02090	-3.9734
Limits				± 20 ppm			
Result				Complies			

Voltage vs. Frequency Stability

TEST CONDITIONS				Reference Frequency: 5280MHz			
				f	fc	Max. Deviation (MHz)	Max. Deviation (ppm)
T nom (°C)	20	V nom (V)	3.85	5280.01210	5280	0.01210	-2.2917
		V max (V)	4.43	5280.01190	5280	0.01190	-2.2538
		V min (V)	3.27	5280.01310	5280	0.01310	-2.4811
Limits				± 20 ppm			
Result				Complies			

Temperature vs. Frequency Stability

TEST CONDITIONS				Reference Frequency: 5280MHz			
				f	fc	Max. Deviation (MHz)	Max. Deviation (ppm)
V nom (V)	3.85	T (°C)	-20	5280.01650	5280	0.01650	-3.1250
		T (°C)	-10	5280.01520	5280	0.01520	-2.8788
		T (°C)	0	5280.00900	5280	0.00900	-1.7045
		T (°C)	10	5280.00990	5280	0.00990	-1.8750
		T (°C)	20	5280.01000	5280	0.01000	-1.8939
		T (°C)	30	5280.00800	5280	0.00800	-1.5152
		T (°C)	40	5280.01650	5280	0.01650	-3.1250
		T (°C)	50	5280.01060	5280	0.01060	-2.0076
		T (°C)	60	5280.01240	5280	0.01240	-2.3485
		T (°C)	70	5280.00700	5280	0.00700	-1.3258
Limits				± 20 ppm			
Result				Complies			

Voltage vs. Frequency Stability

TEST CONDITIONS				Reference Frequency: 5320MHz			
				f	fc	Max. Deviation (MHz)	Max. Deviation (ppm)
T nom (°C)	20	V nom (V)	3.85	5320.02350	5320	0.02350	-4.4173
		V max (V)	4.43	5320.01870	5320	0.01870	-3.5150
		V min (V)	3.27	5320.01640	5320	0.01640	-3.0827
Limits				± 20 ppm			
Result				Complies			

Temperature vs. Frequency Stability

TEST CONDITIONS				Reference Frequency: 5320MHz			
				f	fc	Max. Deviation (MHz)	Max. Deviation (ppm)
V nom (V)	3.85	T (°C)	-20	5320.01170	5320	0.01170	-2.1992
		T (°C)	-10	5320.01030	5320	0.01030	-1.9361
		T (°C)	0	5320.01270	5320	0.01270	-2.3872
		T (°C)	10	5320.00590	5320	0.00590	-1.1090
		T (°C)	20	5320.00550	5320	0.00550	-1.0338
		T (°C)	30	5320.01140	5320	0.01140	-2.1429
		T (°C)	40	5320.02340	5320	0.02340	-4.3985
		T (°C)	50	5320.01480	5320	0.01480	-2.7820
		T (°C)	60	5320.00780	5320	0.00780	-1.4662
		T (°C)	70	5320.02150	5320	0.02150	-4.0414
Limits				± 20 ppm			
Result				Complies			

EUT :	Wireless Digital Terminal	Model Name. :	S611
Temperature :	25 °C	Relative Humidity :	56%
Pressure :	1012 hPa	Test Voltage :	DC 3.85V
Test Mode :	TX Frequency Band 2C (5470-5725MHz)		

Voltage vs. Frequency Stability

TEST CONDITIONS				Reference Frequency: 5500MHz			
				f	fc	Max. Deviation (MHz)	Max. Deviation (ppm)
T nom (°C)	20	V nom (V)	3.85	5500.00432	5500	0.00432	-0.7855
		V max (V)	4.43	5500.00269	5500	0.00269	-0.4891
		V min (V)	3.27	5500.00038	5500	0.00038	-0.0691
Limits				± 20 ppm			
Result				Complies			

Temperature vs. Frequency Stability

TEST CONDITIONS				Reference Frequency: 5500MHz			
				f	fc	Max. Deviation (MHz)	Max. Deviation (ppm)
V nom (V)	3.85	T (°C)	-20	5500.00461	5500	0.00461	-0.8382
		T (°C)	-10	5500.01152	5500	0.01152	-2.0945
		T (°C)	0	5500.00512	5500	0.00512	-0.9309
		T (°C)	10	5500.00525	5500	0.00525	-0.9545
		T (°C)	20	5500.00750	5500	0.00750	-1.3636
		T (°C)	30	5500.00452	5500	0.00452	-0.8218
		T (°C)	40	5500.00389	5500	0.00389	-0.7073
		T (°C)	50	5500.00180	5500	0.00180	-0.3273
		T (°C)	60	5500.00449	5500	0.00449	-0.8164
		T (°C)	70	5500.00720	5500	0.00720	-1.3091
Limits				± 20 ppm			
Result				Complies			

Voltage vs. Frequency Stability

TEST CONDITIONS				Reference Frequency: 5600MHz			
				f	fc	Max. Deviation (MHz)	Max. Deviation (ppm)
T nom (°C)	20	V nom (V)	3.85	5600.00579	5600	0.00579	-1.0339
		V max (V)	4.43	5600.00758	5600	0.00758	-1.3536
		V min (V)	3.27	5600.00695	5600	0.00695	-1.2411
Limits				± 20 ppm			
Result				Complies			

Temperature vs. Frequency Stability

TEST CONDITIONS				Reference Frequency: 5600MHz			
				f	fc	Max. Deviation (MHz)	Max. Deviation (ppm)
V nom (V)	3.85	T (°C)	-20	5600.00860	5600	0.00860	-1.5357
		T (°C)	-10	5600.00237	5600	0.00237	-0.4232
		T (°C)	0	5600.00218	5600	0.00218	-0.3893
		T (°C)	10	5600.00687	5600	0.00687	-1.2268
		T (°C)	20	5600.00939	5600	0.00939	-1.6768
		T (°C)	30	5600.00306	5600	0.00306	-0.5464
		T (°C)	40	5600.00619	5600	0.00619	-1.1054
		T (°C)	50	5600.00636	5600	0.00636	-1.1357
		T (°C)	60	5600.01000	5600	0.01000	-1.7857
		T (°C)	70	5600.00435	5600	0.00435	-0.7768
Limits				± 20 ppm			
Result				Complies			

Voltage vs. Frequency Stability

TEST CONDITIONS				Reference Frequency: 5700MHz			
				f	fc	Max. Deviation (MHz)	Max. Deviation (ppm)
T nom (°C)	20	V nom (V)	3.85	5700.00582	5700	0.00582	-1.0211
		V max (V)	4.43	5700.00749	5700	0.00749	-1.3140
		V min (V)	3.27	5700.00931	5700	0.00931	-1.6333
Limits				± 20 ppm			
Result				Complies			

Temperature vs. Frequency Stability

TEST CONDITIONS				Reference Frequency: 5700MHz			
				f	fc	Max. Deviation (MHz)	Max. Deviation (ppm)
V nom (V)	3.85	T (°C)	-20	5700.01071	5700	0.01071	-1.8789
		T (°C)	-10	5700.00567	5700	0.00567	-0.9947
		T (°C)	0	5700.00452	5700	0.00452	-0.7930
		T (°C)	10	5700.00336	5700	0.00336	-0.5895
		T (°C)	20	5700.00933	5700	0.00933	-1.6368
		T (°C)	30	5700.01096	5700	0.01096	-1.9228
		T (°C)	40	5700.00720	5700	0.00720	-1.2632
		T (°C)	50	5700.00302	5700	0.00302	-0.5298
		T (°C)	60	5700.00527	5700	0.00527	-0.9246
		T (°C)	70	5700.00522	5700	0.00522	-0.9158
Limits				± 20 ppm			
Result				Complies			

EUT :	Wireless Digital Terminal	Model Name. :	S611
Temperature :	25 °C	Relative Humidity :	56%
Pressure :	1012 hPa	Test Voltage :	DC 3.85V
Test Mode :	TX Frequency(5745-5825MHz)		

Voltage vs. Frequency Stability

TEST CONDITIONS				Reference Frequency: 5745MHz			
				f	fc	Max. Deviation (MHz)	Max. Deviation (ppm)
T nom (°C)	20	V nom (V)	3.85	5745.01848	5745	0.01848	-3.2159
		V max (V)	4.43	5745.01286	5745	0.01286	-2.2392
		V min (V)	3.27	5745.01985	5745	0.01985	-3.4547
Limits				± 20 ppm			
Result				Complies			

Temperature vs. Frequency Stability

TEST CONDITIONS				Reference Frequency: 5745MHz			
				f	fc	Max. Deviation (MHz)	Max. Deviation (ppm)
V nom (V)	3.85	T (°C)	-20	5745.01867	5745	0.01867	-3.2492
		T (°C)	-10	5745.01702	5745	0.01702	-2.9634
		T (°C)	0	5745.01057	5745	0.01057	-1.8394
		T (°C)	10	5745.01224	5745	0.01224	-2.1303
		T (°C)	20	5745.00981	5745	0.00981	-1.7070
		T (°C)	30	5745.01106	5745	0.01106	-1.9249
		T (°C)	40	5745.01533	5745	0.01533	-2.6683
		T (°C)	50	5745.01497	5745	0.01497	-2.6054
		T (°C)	60	5745.01356	5745	0.01356	-2.3606
		T (°C)	70	5745.01142	5745	0.01142	-1.9876
Limits				± 20 ppm			
Result				Complies			

Voltage vs. Frequency Stability

TEST CONDITIONS				Reference Frequency: 5785MHz			
				f	fc	Max. Deviation (MHz)	Max. Deviation (ppm)
T nom (°C)	20	V nom (V)	3.85	5785.01130	5785	0.01130	-1.9540
		V max (V)	4.43	5785.01594	5785	0.01594	-2.7560
		V min (V)	3.27	5785.01386	5785	0.01386	-2.3963
Limits				± 20 ppm			
Result				Complies			

Temperature vs. Frequency Stability

TEST CONDITIONS				Reference Frequency: 5785MHz			
				f	fc	Max. Deviation (MHz)	Max. Deviation (ppm)
V nom (V)	3.85	T (°C)	-20	5785.01193	5785	0.01193	-2.0629
		T (°C)	-10	5785.01410	5785	0.01410	-2.4378
		T (°C)	0	5785.01719	5785	0.01719	-2.9712
		T (°C)	10	5785.01028	5785	0.01028	-1.7772
		T (°C)	20	5785.01501	5785	0.01501	-2.5955
		T (°C)	30	5785.01167	5785	0.01167	-2.0180
		T (°C)	40	5785.00924	5785	0.00924	-1.5967
		T (°C)	50	5785.01344	5785	0.01344	-2.3232
		T (°C)	60	5785.01676	5785	0.01676	-2.8968
		T (°C)	70	5785.01654	5785	0.01654	-2.8598
Limits				± 20 ppm			
Result				Complies			

Voltage vs. Frequency Stability

TEST CONDITIONS				Reference Frequency: 5825MHz			
				f	fc	Max. Deviation (MHz)	Max. Deviation (ppm)
T nom (°C)	20	V nom (V)	3.85	5825.00980	5825	0.00980	-1.6831
		V max (V)	4.43	5825.01291	5825	0.01291	-2.2161
		V min (V)	3.27	5825.01847	5825	0.01847	-3.1710
Limits				± 20 ppm			
Result				Complies			

Temperature vs. Frequency Stability

TEST CONDITIONS				Reference Frequency: 5825MHz			
				f	fc	Max. Deviation (MHz)	Max. Deviation (ppm)
V nom (V)	3.85	T (°C)	-20	5825.01036	5825	0.01036	-1.7793
		T (°C)	-10	5825.01589	5825	0.01589	-2.7281
		T (°C)	0	5825.01220	5825	0.01220	-2.0952
		T (°C)	10	5825.00934	5825	0.00934	-1.6030
		T (°C)	20	5825.01023	5825	0.01023	-1.7570
		T (°C)	30	5825.01802	5825	0.01802	-3.0936
		T (°C)	40	5825.01623	5825	0.01623	-2.7867
		T (°C)	50	5825.01030	5825	0.01030	-1.7686
		T (°C)	60	5825.01765	5825	0.01765	-3.0300
		T (°C)	70	5825.01474	5825	0.01474	-2.5299
Limits				± 20 ppm			
Result				Complies			

11. DYNAMIC FREQUENCY SELECTION(DFS)

11.1 APPLICABILITY OF DFS REQUIREMENTS

EUT is client and operates as client without radar detection function.

Table 1: Applicability of DFS Requirements Prior to Use of a Channel

Requirement	Operational Mode		
	Master	Client Without Radar Detection	Client With Radar Detection
Non-Occupancy Period	Yes	Not required	Yes
DFS Detection Threshold	Yes	Not required	Yes
Channel Availability Check Time	Yes	Not required	Not required
U-NII Detection Bandwidth	Yes	Not required	Yes

Table 2: Applicability of DFS requirements during normal operation

Requirement	Operational Mode		
	Master	Client Without Radar Detection	Client With Radar Detection
DFS Detection Threshold	Yes	Not required	Yes
Channel Closing Transmission Time	Yes	Not required	Yes
Channel Move Time	Yes	Not required	Not required
U-NII Detection Bandwidth	Yes	Not required	Yes
Client Beacon Test	N/A	Yes	Yes

Additional requirements for devices with multiple bandwidth modes	Operational Mode	
	Master or Client With Radar Detection	Client Without Radar Detection
U-NII Detection Bandwidth and Statistical Performance Check	All BW modes must be tested	Not required
Channel Move Time and Channel Closing Transmission Time	Test using widest BW mode available	Test using the widest BW mode available for the link
All other tests	Any single BW mode	Not required
Note Frequencies selected for statistical performance check (Section 7.8.4) should include several frequencies within the radar detection bandwidth and frequencies near the edge of the radar detection bandwidth. For 802.11 devices it is suggested to select frequencies in each of the bonded 20 MHz channels and the channel center frequency.		

11.2 INTERFERENCE THRESHOLD VALUES, MASTER OR CLIENT INCORPORATING IN-SERVICE MONITORING

Maximum Transmit Power	Value (see notes 1, 2, and 3)
EIRP \geq 200 milliwatt	-64 dBm
EIRP < 200 milliwatt and power spectral density < 10 dBm/MHz	-62 dBm
EIRP < 200 milliwatt that do not meet the power spectral density requirement	-64 dBm
Note 1: This is the level at the input of the receiver assuming a 0 dBi receive antenna. Note 2: Throughout these test procedures an additional 1 dB has been added to the amplitude of the test transmission waveforms to account for variations in measurement equipment. This will ensure that the test signal is at or above the detection threshold level to trigger a DFS response. Note 3: EIRP is based on the highest antenna gain.	

11.3 DFS RESPONSE REQUIREMENT VALUES

Parameter	Value
Non-occupancy period	Minimum 30 minutes
Channel Availability Check Time	60 seconds
Channel Move Time	10 seconds See Note 1.
Channel Closing Transmission Time	200 milliseconds + an aggregate of 60 milliseconds over remaining 10 second period. See Notes 1 and 2.
U-NII Detection Bandwidth	Minimum 100% of the 99% power bandwidth See Note 3.

Note 1: The instant that the Channel Move Time and the Channel Closing Transmission Time begins is as follows:

- For the Short pulse radar Test Signals this instant is the end of the Burst.
- For the Frequency Hopping radar Test Signal, this instant is the end of the last radar Burst generated.
- For the Long Pulse radar Test Signal this instant is the end of the 12 second period defining the radar transmission.

Note 2: The Channel Closing Transmission Time is comprised of 200 milliseconds starting at the beginning of the Channel Move Time plus any additional intermittent control signals required to facilitate Channel changes (an aggregate of 60 milliseconds) during the remainder of the 10 second period. The aggregate duration of control signals will not count quiet periods in between transmissions.

Note 3: During the U-NII Detection Bandwidth detection test, radar type 0 is used and for each frequency step the minimum percentage of detection is 90%. Measurements are performed with no data traffic.

11.4 SHORT PULSE RADAR TEST WAVEFORMS

As the EUT is a Client Device with no Radar Detection, only one type radar pulse is required for the testing. Radar Pulse type 0 was used in the evaluation of the Client device for the purpose of measuring the Channel Move Time and the Channel Closing Transmission Time.

Radar Type	Pulse Width (µsec)	PRI (µsec)	Number of Pulses	Minimum Percentage of Successful Detection	Minimum Trials
0	1	1428	18	60%	30
1	1	Test A Test B	Roundup $\left(\frac{1}{360} \cdot \frac{19 \cdot 10^6}{PRI_{\mu sec}} \right)$	60%	30
2	1-5	150-230	23-29	60%	30
3	6-10	200-500	16-18	60%	30
4	11-20	200-500	12-16	60%	30
Aggregate (Radar Types 1-4)				80%	120

Test A: 15 unique PRI values randomly selected from the list of 23 PRI values in Table 5a

Test B: 15 unique PRI values randomly selected within the range of 518-3066 µ sec, with a minimum increment of 1 µ sec, excluding PRI values selected in Test A

A minimum of 30 unique waveforms are required for each of the short pulse radar types 2 through 4. For short pulse radar type 1, the same waveform is used a minimum of 30 times. If more than 30 waveforms are used for short pulse radar types 2 through 4, then each additional waveform must also be unique and not repeated from the previous waveforms.

If more than 30 waveforms are used for Short Pulse Radar Type 1, then each additional waveform is generated with Test B and must also be unique and not repeated from the previous waveforms in Tests A or B. The aggregate is the average of the percentage of successful detections of short pulse radar types 1-4.

11.5 CALIBRATION SETUP AND DFS TEST RESULTS

Radar Waveform Calibration Procedure

- 1) A 50 ohm load is connected in place of the spectrum analyzer, and the spectrum analyzer is connected to place of the master
- 2) The interference Radar Detection Threshold Level is $-62\text{dBm} + 0\text{dBi} + 1\text{dB} = -61\text{dBm}$ that had been taken into account the output power range and antenna gain.
- 3) The following equipment setup was used to calibrate the conducted radar waveform. A vector signal generator was utilized to establish the test signal level for radar type 0. During this process there were no transmissions by either the master or client device. The spectrum analyzer was switched to the zero spans (time domain) at the frequency of the radar waveform generator. Peak detection was used. The spectrum analyzer resolution bandwidth (RBW) and video bandwidth (VBW) were set to 3 MHz. The spectrum analyzer had offset -1.0dB to compensate RF cable loss 1.0dB .
- 4) The vector signal generator amplitude was set so that the power level measured at the spectrum analyzer was $-62\text{dBm} + 0\text{dBi} + 1\text{dB} = -61\text{dBm}$. Capture the spectrum analyzer plots on short pulse radar waveform.

11.6 CONDUCTED CALIBRATION SETUP

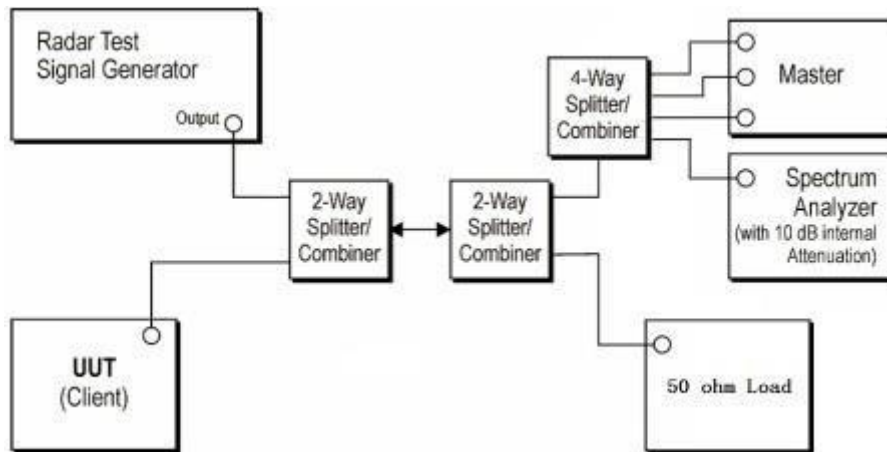

11.7 RADAR WAVEFORM CALIBRATION RESULT

Reference DFS test signal

5290MHz

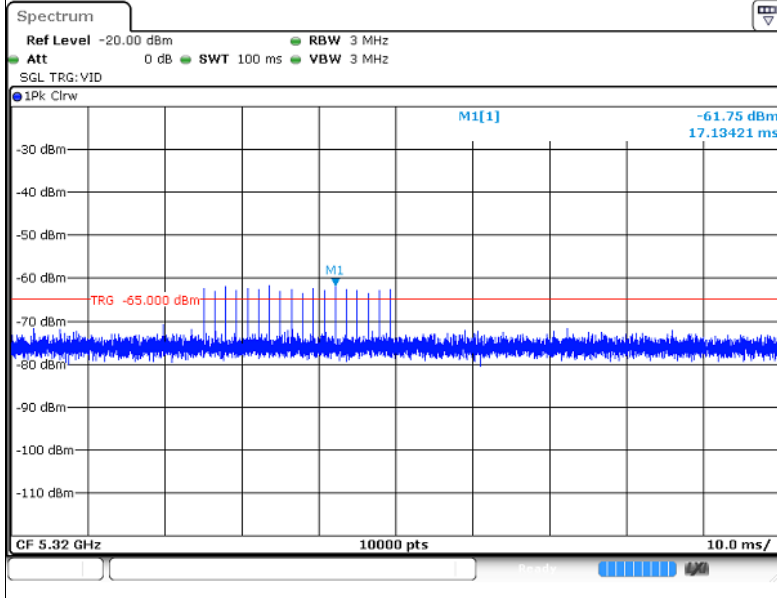

Reference DFS test signal

5530MHz

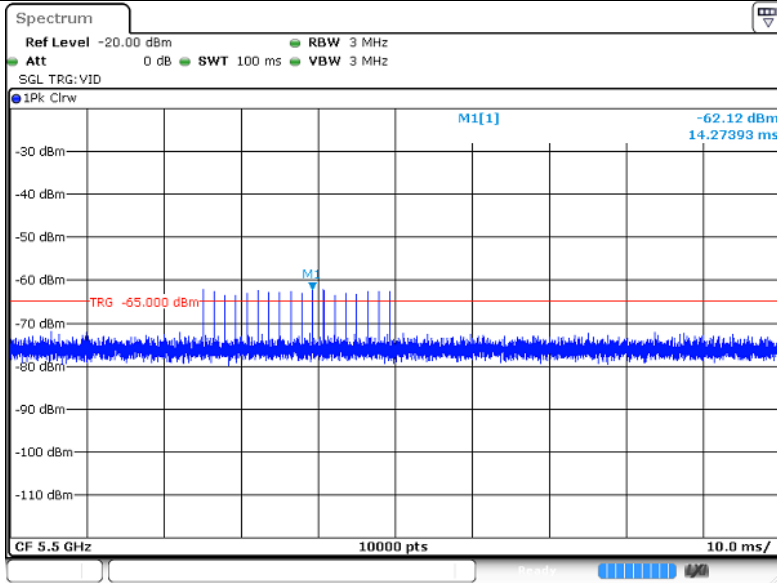

EUT data traffic (Slave)

5290MHz

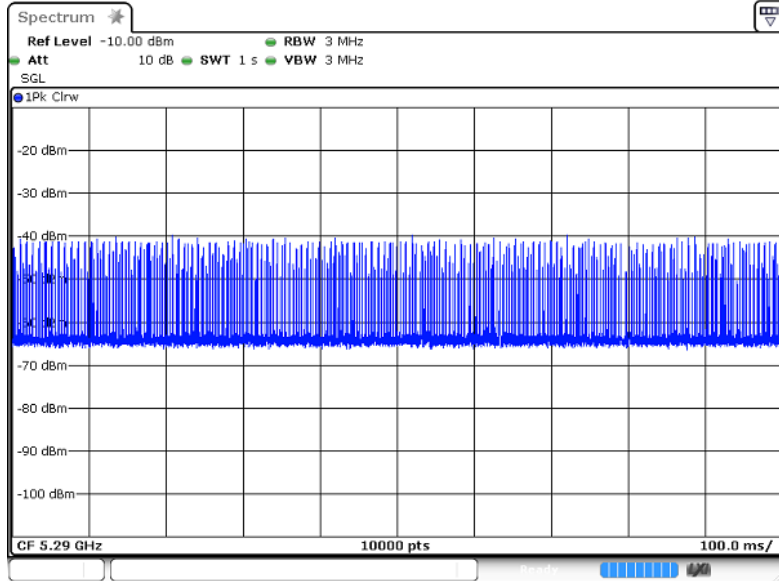

EUT data traffic (Slave)

5530MHz

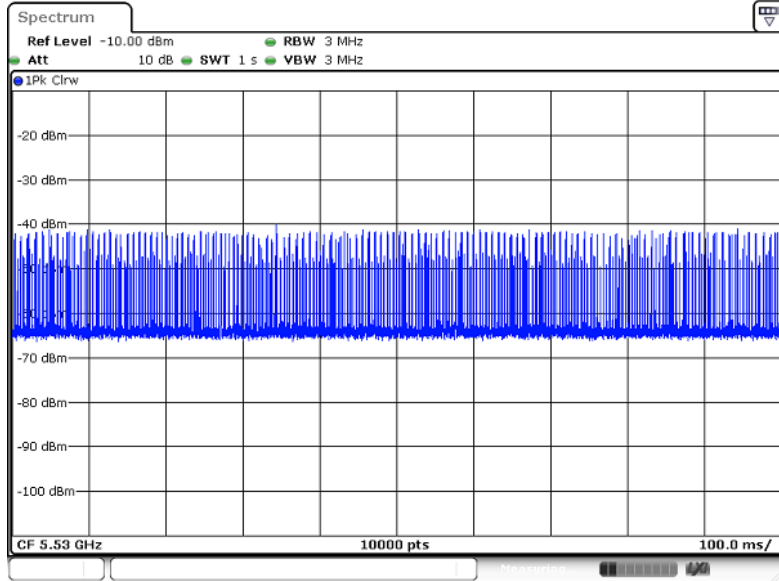

11.8 IN-SERVICE MONITORING: CHANNEL MOVE TIME, CHANNEL CLOSING TRANSMISSION TIME AND NON-OCCUPANCY PERIOD

TEST CONFIGURATION:

Setup for Client with injection at the Master

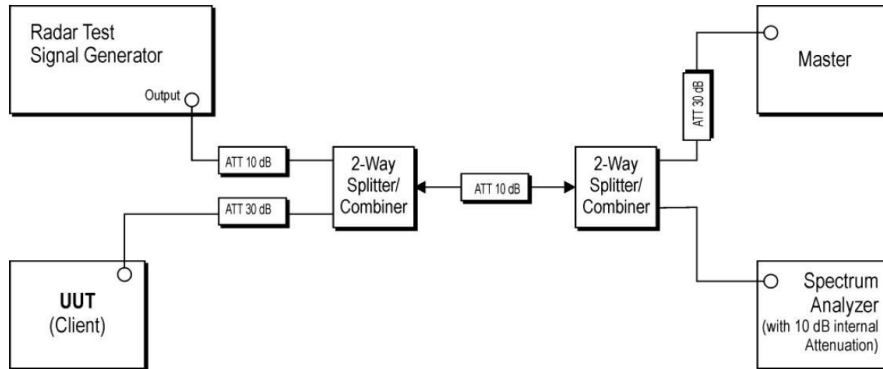

TEST PROCEDURE:

1. The radar pulse generator is setup to provide a pulse at frequency that the master and client are operating. A type 0 radar pulse with a 1us pulse width and a 1428us PRI is used for the testing.
2. The vector signal generator is adjusted to provide the radar burst (18 pulses) at the level of approximately -61dBm at the antenna port of the master device
3. A trigger is provided from the pulse generator to the DFS monitoring system in order to capture the traffic and the occurrence of the radar pulse.
4. EUT will associate with the master at channel. The file "iperf.exe" specified by the FCC is Streamed from the PC 2 through the master and the client device to the PC 1 and played in full motion video using Media Player Classic Ver. 6.4.8.6 in order to properly load the network for the entire period of the test.
5. When radar burst with a level equal to the DFS Detection Threshold +1dB is generated on the operating channel of the U-NII device. At time T0 the radar waveform generator sends a burst of pulse of the radar waveform at Detection Threshold +1dB.
6. Observe the transmissions of the EUT at the end of the radar Burst on the Operating Channel Measure and record the transmissions from the UUT during the observation time (Channel Move Time). One 15 seconds plot is reported for the Short Pulse Radar Type 0. The plot for the Short Pulse Radar Types start at the end of the radar burst. The Channel Move Time will be calculated based on the zoom In 600ms plot of the Short Pulse Radar Type
7. Measurement of the aggregate duration of the Channel Closed Transmission Time method. With the spectrum analyzer set to zero span tuned to the center frequency of the EUT operating channel at the radar simulated frequency, peak detection, and max hold, the dwell time per bin is given by: $Dwell (0.3ms) = S (12000ms) / B (4000)$; where Dwell is the dwell time per spectrum analyzer sampling bin, S is sweep time and B is the number of spectrum analyzer sampling bins. An upper bound of the aggregate duration of the intermittent control signals of Channel Closing Transmission Time is calculated by: $C (ms) = N \times Dwell (0.3ms)$; where C is the Closing Time, N is the number of spectrum analyzer sampling bins (intermittent control signals) showing a U-NII transmission and Dwell is the dwell time per bin.
8. Measurement the EUT for more than 30 minutes following the channel move time to verify that no transmission or beacons occur on this channel.

TEST MODE:

Please refer to the clause 2.2

11.9 RESULT OF CHANNEL MOVE TIME, CHANNEL CLOSING TRANSMISSION TIME AND NON-OCCUPANCY PERIOD FOR CLIENT BEACON TEST

BW/ Channel	Maximum EIRP Power(dBm)	Test Item	Test Result	Limit	Result
80MHz/ 5290MHz	12.4	Channel Move Time	2208.05ms	< 10s	PASS
		Channel Closing Transmission Time	52.00ms	< 60ms	PASS
80MHz/ 5530MHz	12.5	Channel Move Time	1321.45ms	< 10s	PASS
		Channel Closing Transmission Time	56.55ms	< 60ms	PASS

80MHz/5290MHz

Band 2A Channel Move Time & Channel Closing Transmission Time

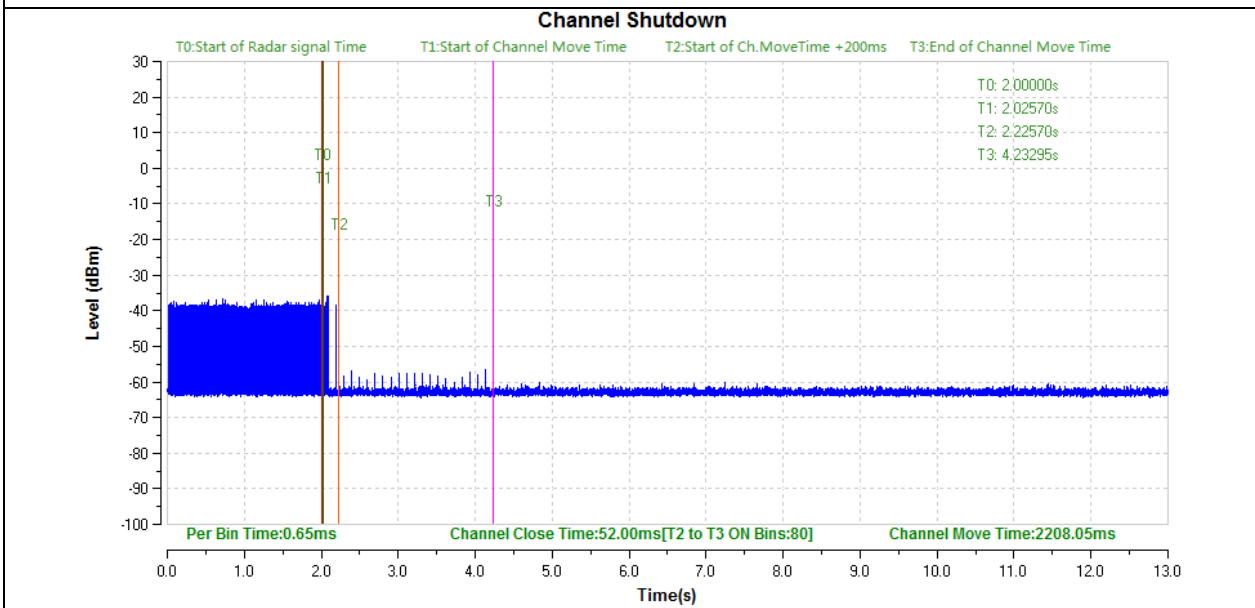

80MHz/5530MHz

Band 2C Channel Move Time & Channel Closing Transmission Time

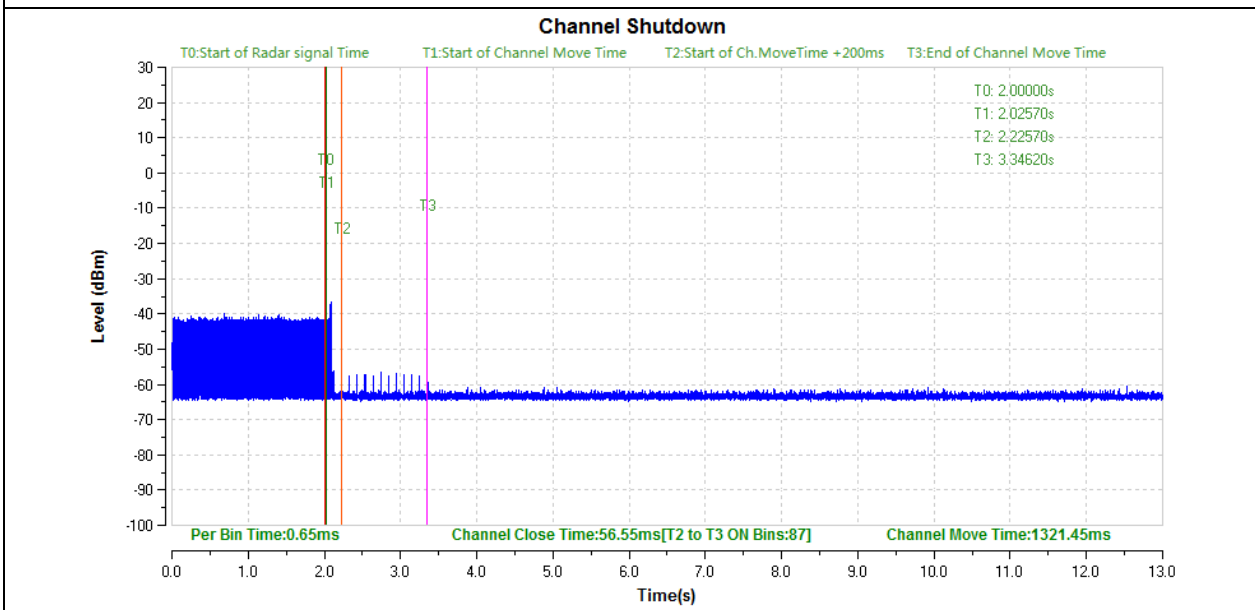

12. ANTENNA REQUIREMENT

12.1 STANDARD REQUIREMENT

15.203 requirement: For intentional device, according to 15.203: an intentional radiator shall be designed to ensure that no antenna other than that furnished by the responsible party shall be used with the device.

12.2 EUT ANTENNA

The EUT antenna is permanent attached FPCB antenna(antenna gain:0.9dBi). It comply with the standard requirement.

END OF REPORT