

Goodlark GT100 Bluetooth Headset

Thank you for choosing and using Lark's TWS Intelligent Wireless Earphone E-100. We will assist you to operate this Bluetooth earphone. Before using the product, you need to know how to operate your cellphone or other Bluetooth device function.

The left and right earphone of this product can be used separately (mono) or for pairing (stereo) , Stylish in appearance, and high quality stereo, Enrich & enhance your lifestyle and enjoy the quality of music Anytime, Anywhere~

Product function and parameters

Product model: GT100

Type: Half-in-ear touch Bluetooth earphone

The left and right earphone can be used separately (mono) and can be used in a pair (stereo)

G sensor touch to wake up

Contact charging, including charging box

Goodlark APP, massive audio content, high-quality listening.

Wireless Bluetooth earphone

Product model: GT100

Executive Standard: Q/DKBA 2425-2017

Bluetooth version: BT 5.0 Bluetooth frequency: 2.4G Hz

Bluetooth audio decoding format: SBC

Bluetooth distance: 360° in all directions up to 15m (close-fitting test without break)

Sensitivity: 105dB SPL +/-3dB @1KHz/1mW

Operation mode: BT/BT

Speaker unit: 13mm*2, Mic: MEMS

Battery capacity: single earphone 40mAh, charging box 500mAh

Playback time: 3 hours for listening to music, 30 hours for total listening time

Charging time: 30 minutes

Waterproof grade: IP6X

Product weight: 4.9g for single earphone, 60g for charging box

GT100 Bluetooth earphone is compatible with Android and iOS system. In order to enhance your experience, please use the cellphone to scan the following QR code before your operation, or search for "Goodlark" in major application markets to download and install APP.

Code

Product instructions

1. Pair the earphone with the cellphone, follow the steps below

1) Open the charging box, turn on the Bluetooth function of the cellphone, search for the Bluetooth device Goodlark-GT100, and then click to connecting.

2) When the prompt tone "Goodlark" come from the earphone, the pairing mode has been connected.

Note: When using the single ear for the first time, remove the right side earphone from the charging box and close the charging box cover, then pair it. (The left side earphone does not need to be paired)

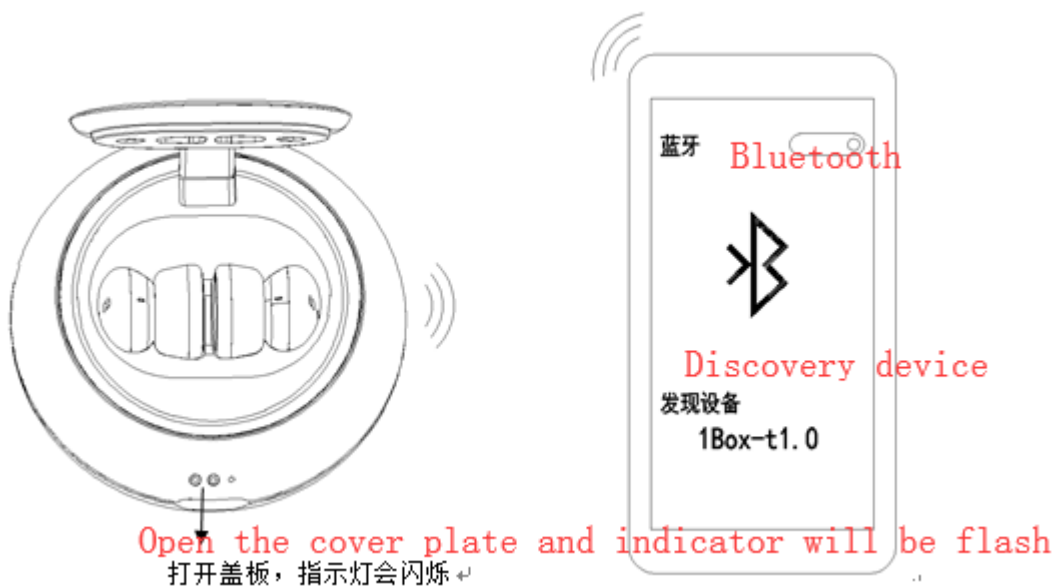
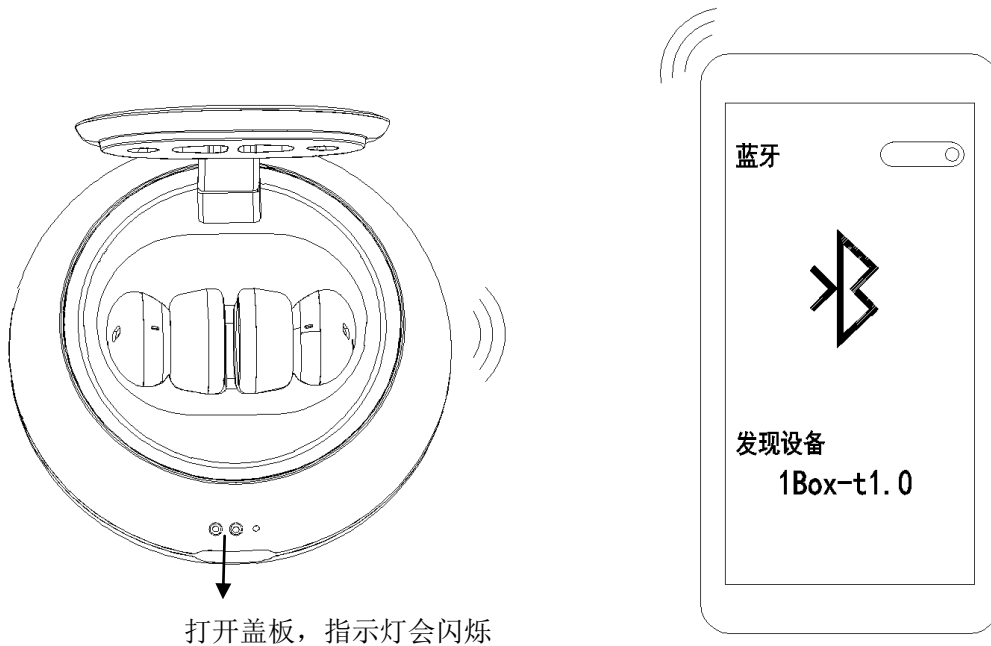

2. Insert into the ear canal

Insert earplugs into your ears and rotate them to fit into your ear canal

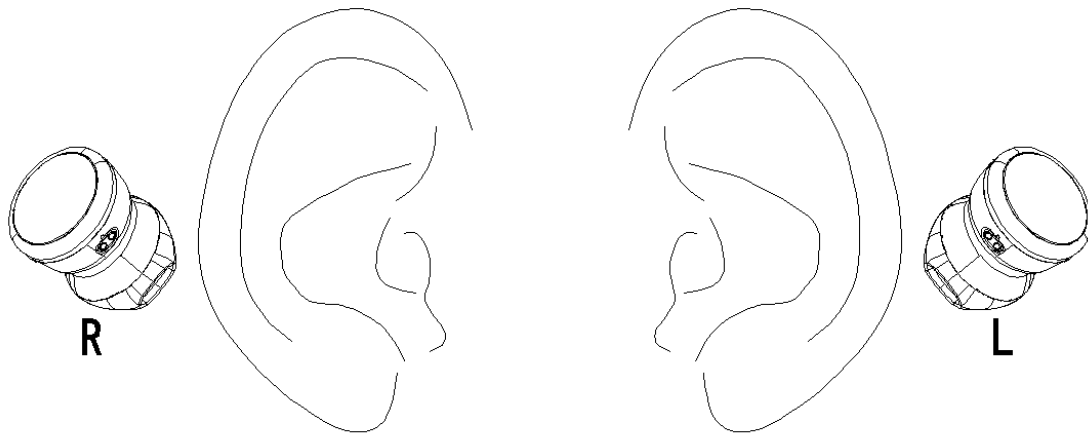

3. Fingertip wake up

The left side earphone double-click to wake-up function, the user can set up the specific content of wake-up on the APP side, the Android cellphone is defaults to Goodlark APP wake-up, and the Apple cellphone is defaults to siri wake-up.

4. Music play mode

When you put on your earphones, the cellphone music APP is playing status.

Play/pause music: put-on/remove any earphone

Play the next song: double-click on the right side earphone

5. Calling mode

Operate on either side of the earphone, double-click to call, and double-click to hang up

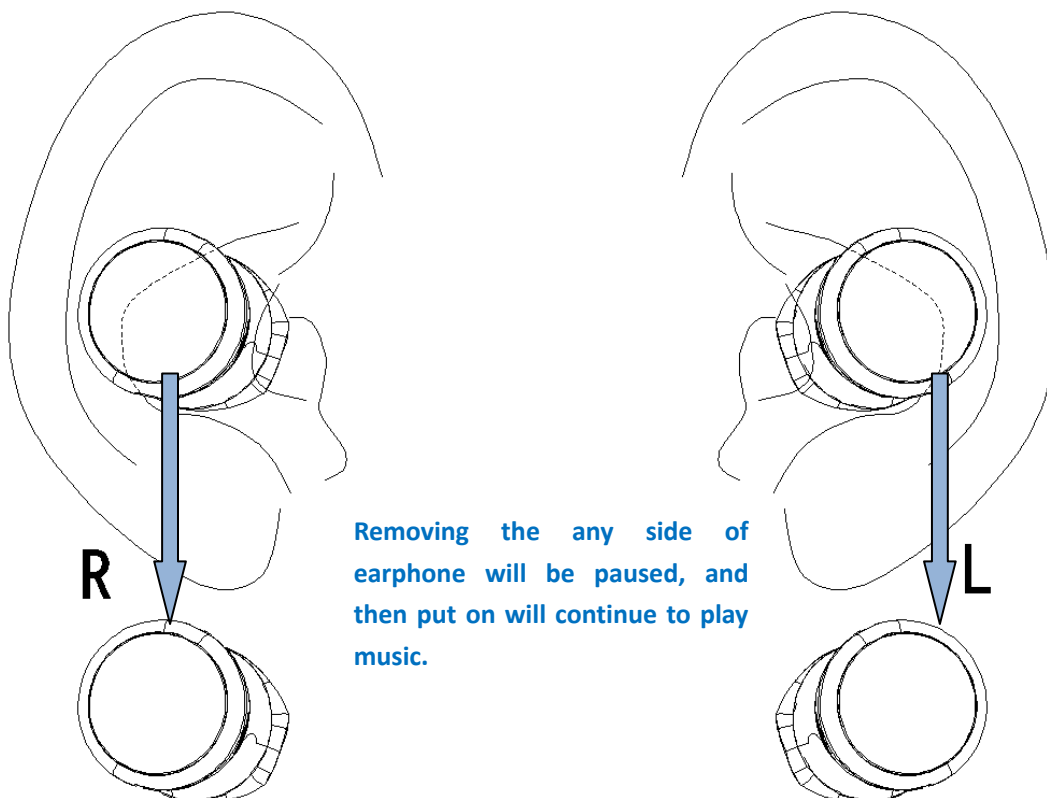

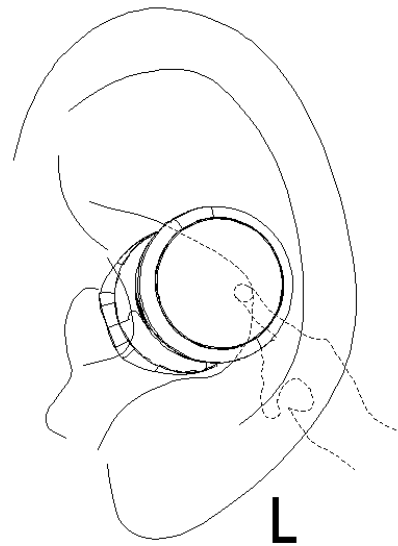
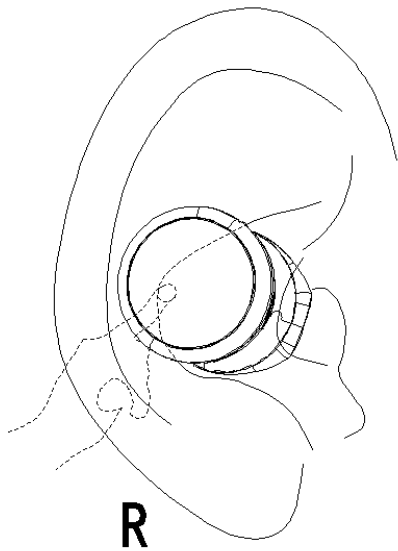

**Double-click to play the next song,
double-click to answer the call,
double-click to hang up**
single earphone used

**Click to wake-up the Goodlark
double-click to answer the call,
double-click to hang up**

music play mode

Play/pause music: put-on/remove earphone

Play next song: double-click earphone

Calling mode

answer/hang-up the phone: double-click earphone

other mode

wake-up Goodlark/siri :double-click earphone

return connecting and re-charging

Open the charging box cover, put in the headset, automatically charge and back to the phone

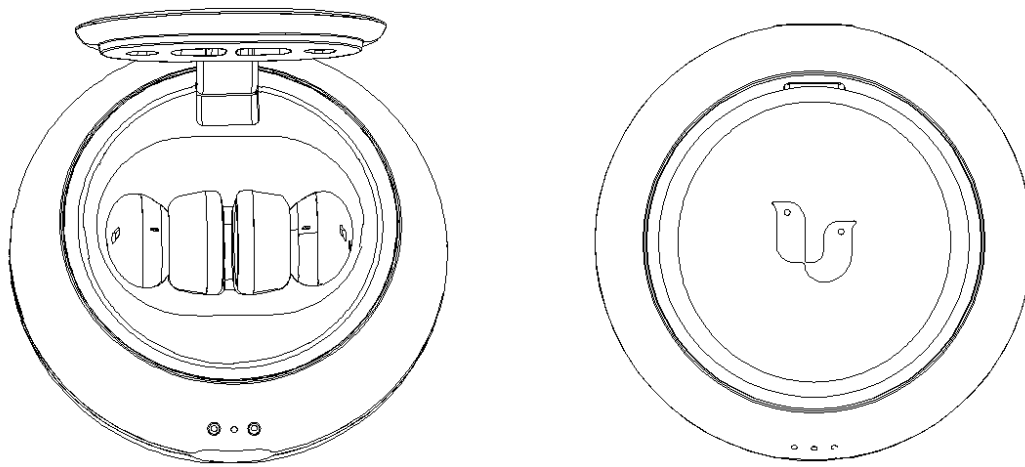
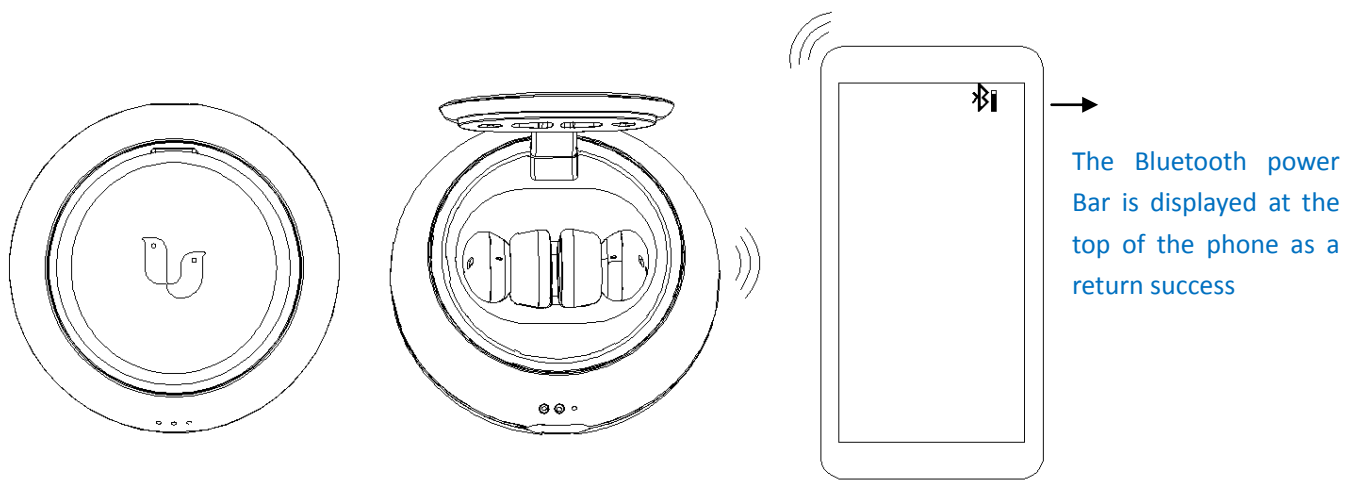

After two headphones are placed in the storage box and covered with a cover, the two lights flashing on the left are identified as starting into charging mode orange lights are considered low power

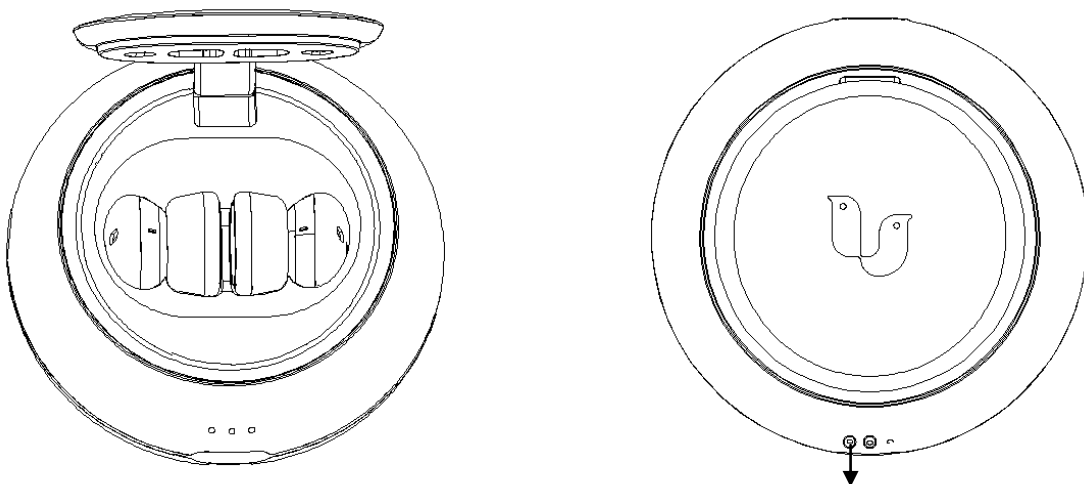

Orange lighting reminds charging box is low power

other else notice

When connecting with a new device, ignore this device on the original device upon general-Bluetooth

announcements of attention

Do not place this headset in the position of the airbag in the car, which can cause serious damage when the airbag pops up

Do not let children play with this headset, small parts will be another child's risk of suffocation

Where flammable, blasting points or potential explosive environments may require users to turn off electronic equipment and radio devices, please be aware of the instructions when entering a specific range.

Please turn off the headset before boarding and do not use this headset in the aircraft

To protect your hearing, do not turn the volume too large

Do not use this product for long periods of time in wet environments and rain

maintainance

Turn off the headset before putting the headset in your pocket or handbag

Do not use a dissolved detergent to clean the headset

Do not allow headphones to receive direct sunlight for long periods of time

Do not dispose of headphones in the fire, which can cause an explosion

Do not let the headset touch sharp objects, which can cause scratches and wear

Do not attempt to disassemble the headset because it does not contain any repair components

When not using headphones for long periods of time, keep them in a cool, dry place to avoid extreme temperatures and dust

Charge the headset at least once a month to extend battery life

Avoid charging the headset where the temperature is too high or too low.

NOTE: This equipment has been tested and found to comply with the limits for a Class B digital device, pursuant to part 15 of the FCC Rules. These limits are designed to provide reasonable protection against harmful interference in a residential installation. This equipment generates uses and can radiate radio frequency energy and, if not installed and used in accordance with the instructions, may cause harmful interference to radio communications. However, there is no guarantee that interference will not occur in a particular installation. If this equipment does cause harmful interference to radio or television reception, which can be determined by turning the equipment off and on, the user is encouraged to try to correct the interference by one or more of the following measures:

- Reorient or relocate the receiving antenna.
- Increase the separation between the equipment and receiver.
- Connect the equipment into an outlet on a circuit different from that to which the receiver is connected.
- Consult the dealer or an experienced radio/TV technician for help

Changes or modifications not expressly approved by the party responsible for compliance could void the user's authority to operate the equipment.

This device complies with Part 15 of the FCC Rules. Operation is subject to the following two conditions:

(1) this device may not cause harmful interference, and

(2) this device must accept any interference received, including interference that may cause undesired operation.

Brand owner: Shenzhen Lark Acoustics

Consumer services hot line :4008387288

网址 : <http://www.goodlark.com.cn>