

# FCC C2PC Test Report

**FCC ID** : 2ASKHAQG01  
**Equipment** : ArrowGVI-IP67  
**Model No.** : 4-6201-10  
(Please refer to section 1.1.1 for more details)  
**Brand Name** : PHILLIPS CONNECT TECHNOLOGIES  
**Applicant** : PHILLIPS CONNECT TECHNOLOGIES LLC  
**Address** : 5231 California Avenue, Suite 110, Irvine,  
California 92617, United States  
**Standard** : 47 CFR FCC Part 27  
**Received Date** : Mar. 30, 2022  
**Tested Date** : Apr. 26, 2022

We, International Certification Corporation, would like to declare that the tested sample has been evaluated and in compliance with the requirement of the above standards. The test results contained in this report refer exclusively to the product. It shall not be reproduced except in full without the written approval of our laboratory.

Reviewed by:

Approved by:

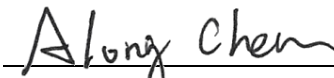
  
\_\_\_\_\_  
Along Chen / Assistant Manager

  
\_\_\_\_\_  
Gary Chang / Manager

---

## Table of Contents

<b>1</b>	<b>GENERAL DESCRIPTION .....</b>	<b>5</b>
1.1	Information.....	5
1.2	Local Support Equipment List .....	6
1.3	Test Setup Chart .....	6
1.4	The Equipment List .....	7
1.5	Test Standards .....	7
1.6	Reference Guidance .....	7
1.7	Deviation from Test Standard and Measurement Procedure.....	7
1.8	Measurement Uncertainty .....	8
<b>2</b>	<b>TEST CONFIGURATION.....</b>	<b>9</b>
2.1	Testing Condition .....	9
2.2	Testing Facility .....	9
2.3	The Worst Test Modes and Channel Details .....	9
<b>3</b>	<b>TEST RESULTS .....</b>	<b>10</b>
3.1	Radiated Emissions.....	10
<b>4</b>	<b>TEST LABORATORY INFORMATION .....</b>	<b>12</b>

### Appendix A. Radiated Emissions

---

## Release Record

Report No.	Version	Description	Issued Date
FG233001P27	Rev. 01	Initial issue	May 25, 2022

## Summary of Test Results

FCC Rules	Test Items	Measured	Result
2.1053 27.53(c) 27.53(g) 27.53(h)	Radiated Emissions	Meet the requirement of limit	Pass

**Declaration of Conformity:**

The test results with all measurement uncertainty excluded are presented in accordance with the regulation limits or requirements declared by manufacturers.

**Comments and Explanations:**

The declared of product specification for EUT presented in the report are provided by the manufacturer, and the manufacturer takes all the responsibilities for the accuracy of product specification.

# 1 General Description

## 1.1 Information

This is a Class II Permissive Change report (C2PC).

Difference: different enclosure for adding O-ring, remove sim door, lens and connector with extension cable and replace user manual for C2PC.

### 1.1.1 Product Details

Brand Name	Model Name	Product Name	Product Description
PHILLIPS CONNECT TECHNOLOGIES	4-6201-10	ArrowGVI-IP67	LTE Cellular GPS Tracker

### 1.1.2 Specification of the Equipment under Test (EUT)

Operating Frequency	LTE Band 4: 1710 MHz – 1755 MHz LTE Band 12: 699 MHz – 716 MHz LTE Band 13: 777 MHz – 787 MHz
Modulation	QPSK, 16QAM
UE Category	M1
Release Version	13

### 1.1.3 Antenna Details

Ant. No.	Type	Connector	Gain (dBi)	Remark
1	Monopole	No	0.3	LTE Band 12
			-0.6	LTE Band 13
			1.1	LTE Band 4

### 1.1.4 Power Supply Type of Equipment under Test (EUT)

Power Supply Type	DC 12V
-------------------	--------

### 1.1.5 Accessories

N/A

## 1.2 Local Support Equipment List

Support Equipment List					
No.	Equipment	Brand	Model	FCC ID	Remarks
1	DC Battery	YUASA	TX-46B24R	---	---

## 1.3 Test Setup Chart

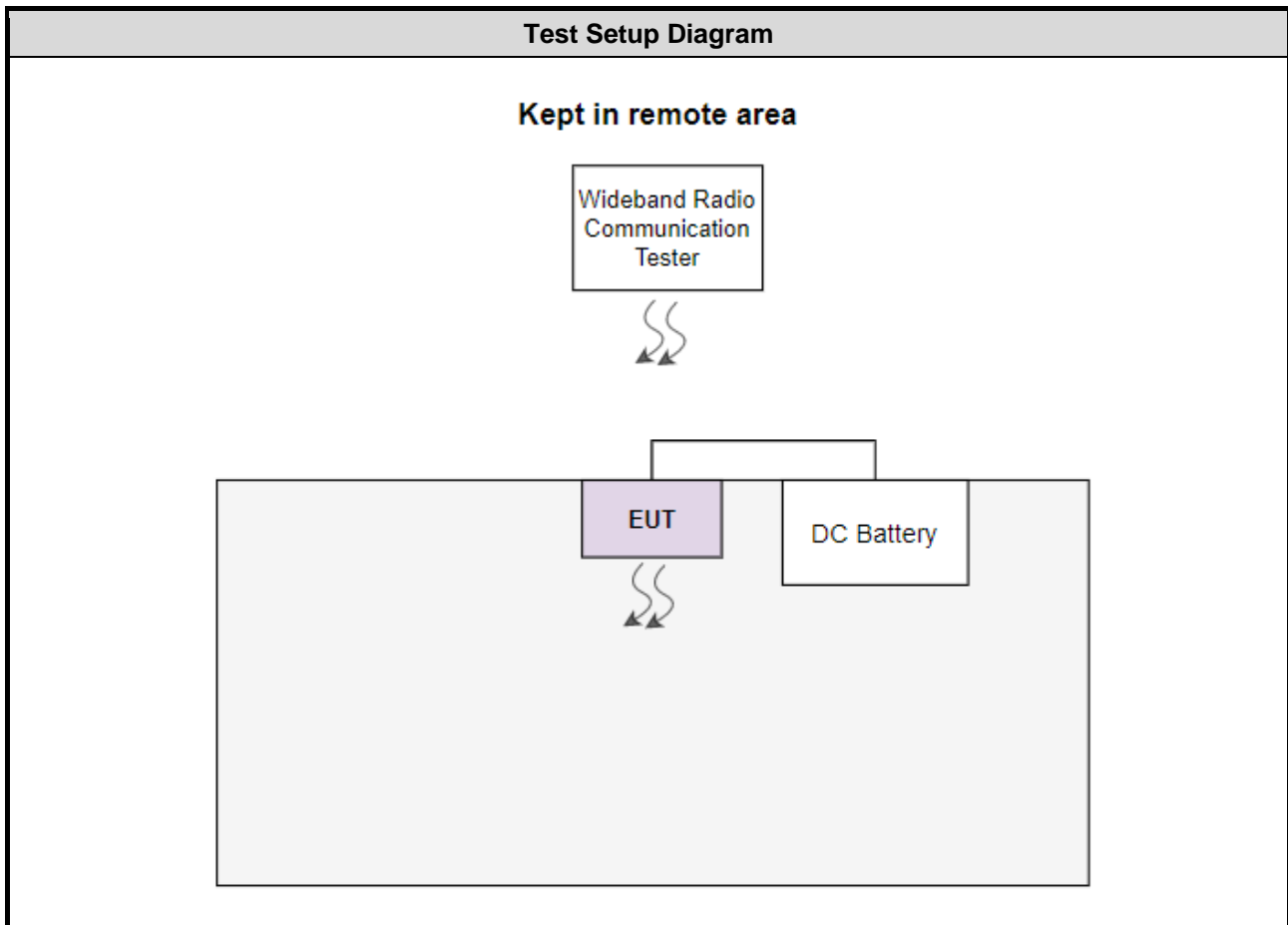

## 1.4 The Equipment List

Test Item	Radiated Emission				
Test Site	966 chamber1 / (03CH01-WS)				
Tested Date	Apr. 26, 2022				
Instrument	Brand	Model No.	Serial No.	Calibration Date	Calibration Until
Wideband Radio Communication Tester	R&S	CMW500	106070	Mar. 08, 2022	Mar. 07, 2023
Receiver	R&S	ESR3	101657	Mar. 15, 2022	Mar. 14, 2023
Spectrum Analyzer	R&S	FSV40	101498	Nov. 29, 2021	Nov. 28, 2022
Loop Antenna	R&S	HFH2-Z2	100330	Nov. 08, 2021	Nov. 07, 2022
Bilog Antenna	SCHWARZBECK	VULB9168	VULB9168-522	Jun. 30, 2021	Jun. 29, 2022
Horn Antenna 1G-18G	SCHWARZBECK	BBHA 9120 D	BBHA 9120 D 1096	Dec. 03, 2021	Dec. 02, 2022
Horn Antenna 18G-40G	SCHWARZBECK	BBHA 9170	BBHA 9170508	Jan. 11, 2022	Jan. 10, 2023
Preamplifier	EMC	EMC02325	980225	Jun. 29, 2021	Jun. 28, 2022
Preamplifier	Agilent	83017A	MY39501308	Sep. 28, 2021	Sep. 27, 2022
Preamplifier	EMC	EMC184045B	980192	Jul. 14, 2021	Jul. 13, 2022
Loop Antenna Cable	KOAX KABEL	101354-BW	101354-BW	Oct. 05, 2021	Oct. 04, 2022
LF cable 3M	Woken	CFD400NL-LW	CFD400NL-001	Oct. 05, 2021	Oct. 04, 2022
LF cable 11M	EMC	EMCCFD400-NW-N W-11000	200801	Oct. 05, 2021	Oct. 04, 2022
LF cable 1M	EMC	EMCCFD400-NM-N M-1000	160502	Oct. 05, 2021	Oct. 04, 2022
RF Cable	EMC	EMC104-35M-35M-8000	210920	Oct. 05, 2021	Oct. 04, 2022
RF Cable	HUBER+SUHNER	SUCOFLEX104	MY16019/4	Oct. 05, 2021	Oct. 04, 2022
Measurement Software	AUDIX	e3	6.120210g	NA	NA

Note: Calibration Interval of instruments listed above is one year.

## 1.5 Test Standards

47 CFR FCC Part 27  
ANSI C63.26-2015

## 1.6 Reference Guidance

FCC KDB 412172 D01 Determining ERP and EIRP v01r01  
FCC KDB 971168 D01 Power Meas License Digital Systems v03r01  
FCC KDB 971168 D02 Misc Rev Approv License Devices v02r01

## 1.7 Deviation from Test Standard and Measurement Procedure

None

## 1.8 Measurement Uncertainty

The measurement uncertainties given below are based on a 95% confidence level (based on a coverage factor (k=2)).

Measurement Uncertainty	
Parameters	Uncertainty
Radiated emission $\leq$ 1GHz	$\pm 3.41$ dB
Radiated emission $>$ 1GHz	$\pm 4.59$ dB



## 2 Test Configuration

### 2.1 Testing Condition

Test Item	Test Site	Ambient Condition	Tested By
Radiated Emissions	03CH01-WS	24°C / 65%	Roger Lu

### 2.2 Testing Facility

<b>Test Laboratory</b>	International Certification Corporation
<b>Test Site</b>	03CH01-WS
<b>Address of Test Site</b>	No.3-1, Lane 6, Wen San 3rd St., Kwei Shan Dist., Tao Yuan City 33381, Taiwan (R.O.C.)

- FCC Designation No.: TW2732
- FCC site registration No.: 181692
- ISED#: 10807A
- CAB identifier: TW2732

### 2.3 The Worst Test Modes and Channel Details

LTE Band 12			
Test item	Channel Bandwidths	Modulation	Test channel
Radiated Emission ≤ 1GHz	5 MHz	QPSK	23095
Radiated Emission > 1GHz	5 MHz	QPSK	23095
LTE Band 13			
Test item	Channel Bandwidth	Modulation	Test channel
Radiated Emission ≤ 1GHz	5 MHz	QPSK	23230
Radiated Emission > 1GHz	5 MHz	QPSK	23230
LTE Band 4			
Test item	Channel Bandwidth	Modulation	Test channel
Radiated Emission ≤ 1GHz	3MHz	QPSK	19965
Radiated Emission > 1GHz	3MHz	QPSK	19965
<b>Note:</b> The EUT was pretested with 3 orientations placed on the table for the radiated emission measurement – X, Y, and Z-plane. The <b>Y-plane</b> results were found as the worst case and were shown in this report.			

## 3 Test Results

### 3.1 Radiated Emissions

#### 3.1.1 Limit of Radiated Emissions

LTE Band 4/ 12/ 13

The power of any emission outside of the authorized operating frequency ranges must be attenuated below the transmitting power (P) by a factor of at least  $43 + 10 \log(P)$  dB equal to -13dBm.

LTE Band 13

For operations in the 775-788 MHz emissions in the band 1559-1610 MHz shall be limited to -70 dBW/MHz equivalent isotropically radiated power (EIRP) for wideband signals, and -80 dBW EIRP for discrete emissions of less than 700 Hz bandwidth.

#### 3.1.2 Test Procedures

1. Measurement is made at a semi-anechoic chamber that incorporates a turntable allowing a EUT rotation of  $360^\circ$ . A continuously-rotating, remotely-controlled turntable is installed at the test site to support the EUT and facilitate determination of the direction of maximum radiation for each EUT emission frequency. For emissions testing at or below 1 GHz, the table height is 80 cm above the reference ground plane. For emission measurements above 1 GHz, the table height is 1.5 m.
2. Measurement is made with the antenna positioned in both the horizontal and vertical planes of polarization. The measurement antenna is varied in height (1m ~ 4m) above the reference ground plane to obtain the maximum signal strength. Distance between EUT and antenna is 3 m.
3. This investigation is performed with the EUT rotated  $360^\circ$ , the antenna height scanned between 1 m and 4 m, and the antenna rotated to repeat the measurements for both the horizontal and vertical antenna polarizations.
4. After finding the max radiated emission, substitution method will be used for getting effective radiated power. EUT will be removed and substitution antenna will be placed at same position. Signal generator will output CW signal to substitution antenna through a RF cable. Rotate turntable and move antenna to find maximum radiated emission. Adjust output power of signal generator to let the maximum radiated emission is same as step 3. Record the output power level.
5. E.I.R.P = output power of step 4 + gain of substitution antenna – cable loss of RF cable. ERP can be calculated by below formula:  
 $E.R.P = E.I.R.P - 2.15dB$ .

### 3.1.3 Test Setup

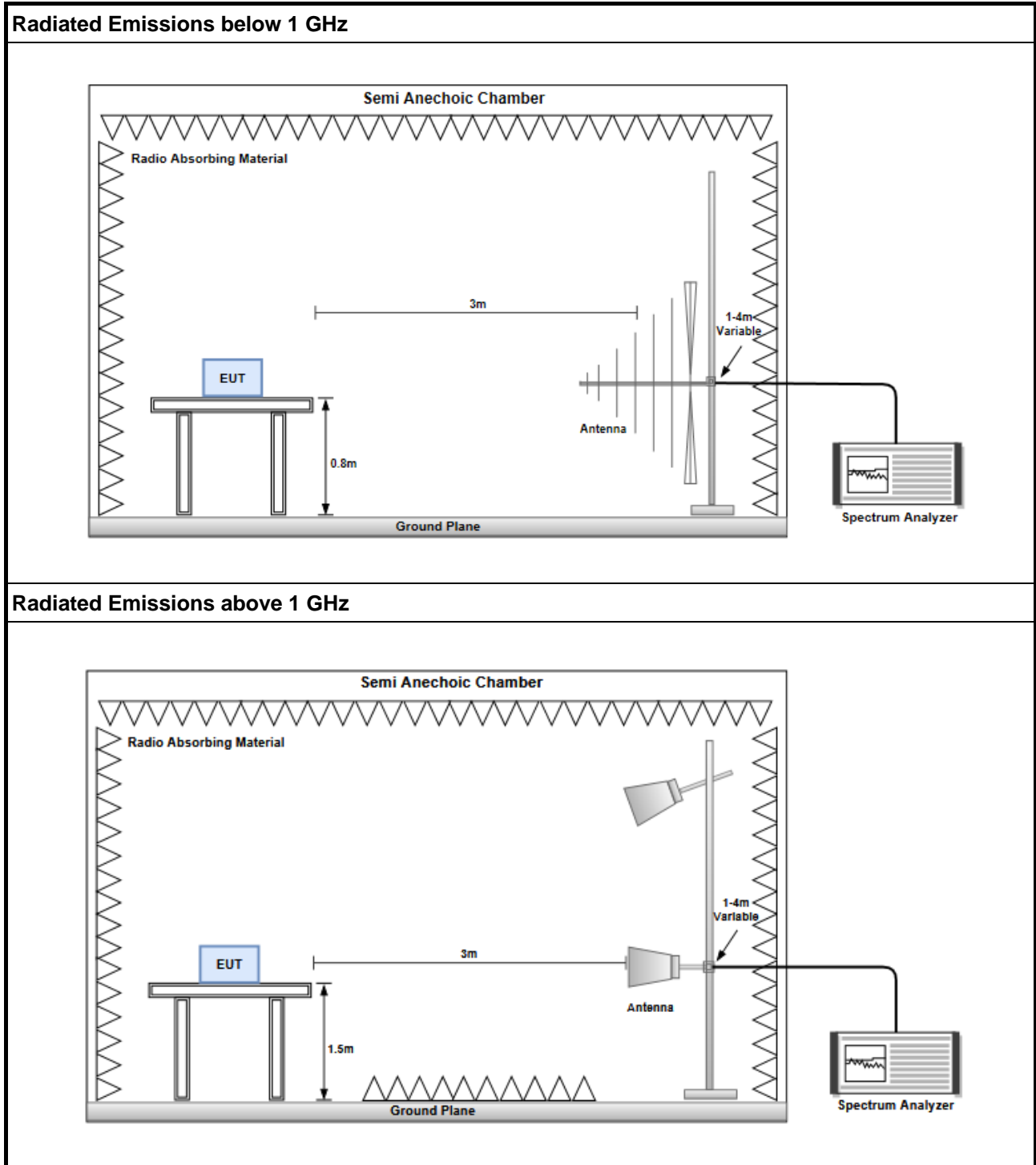

### 3.1.4 Test Results

Refer to Appendix A.

## 4 Test laboratory information

Established in 2012, ICC provides foremost EMC & RF Testing and advisory consultation services by our skilled engineers and technicians. Our services employ a wide variety of advanced edge test equipment and one of the widest certification extents in the business.

International Certification Corporation (EMC and Wireless Communication Laboratory), it is our definitive objective is to institute long term, trust-based associations with our clients. The expectation we set up with our clients is based on outstanding service, practical expertise and devotion to a certified value structure. Our passion is to grant our clients with best EMC / RF services by oriented knowledgeable and accommodating staff.

Our Test sites are located at Linkou District and Kwei Shan District. Location map can be found on our website <http://www.icertifi.com.tw>.

### **Linkou**

Tel: 886-2-2601-1640

No.30-2, Ding Fwu Tsuen, Lin Kou  
District, New Taipei City, Taiwan  
(R.O.C.)

### **Kwei Shan**

Tel: 886-3-271-8666

No.3-1, Lane 6, Wen San 3rd  
St., Kwei Shan Dist., Tao Yuan  
City 33381, Taiwan (R.O.C.)  
No.2-1, Lane 6, Wen San 3rd  
St., Kwei Shan Dist., Tao Yuan  
City 33381, Taiwan (R.O.C.)

### **Kwei Shan Site II**

Tel: 886-3-271-8640

No.14-1, Lane 19, Wen San 3rd  
St., Kwei Shan Dist., Tao Yuan  
City 333, Taiwan (R.O.C.)

If you have any suggestion, please feel free to contact us as below information.

Tel: 886-3-271-8666

Fax: 886-3-318-0155

Email: ICC\_Service@icertifi.com.tw

==END==



Emissions below 1GHz

Mode	LTE Band 4, QPSK, CB:3 MHz, RB Size: 1 RB start: 0, index: 0, Channel: 19965						
Frequency (MHz)	Antenna Polarity	E.I.R.P (dBm)	Limit (dBm)	Margin (dB)	S.A Reading (dBm)	S.G Power Value (dBm)	Correction Factor (dB)
30.97	H	-70.29	-13	-57.29	-74.74	-51.04	-19.25
249.22	H	-72.94	-13	-59.94	-72.14	-71.57	-1.37
333.61	H	-71.13	-13	-58.13	-71.19	-69.87	-1.26
474.26	H	-68.34	-13	-55.34	-71.6	-66.88	-1.46
549.92	H	-69.08	-13	-56.08	-73.56	-67.69	-1.39
672.14	H	-67.9	-13	-54.9	-74.4	-66.05	-1.85
48.43	V	-64.22	-13	-51.22	-63.49	-47.78	-16.44
89.17	V	-63.85	-13	-50.85	-63.77	-58.73	-5.12
130.88	V	-65.39	-13	-52.39	-68.42	-58.81	-6.58
342.34	V	-69.48	-13	-56.48	-71.99	-68.24	-1.24
467.47	V	-68.23	-13	-55.23	-73.04	-66.76	-1.47
546.04	V	-65.95	-13	-52.95	-72.13	-64.56	-1.39

Note: EIRP = S.G Power value + Correction factor

Emissions above 1GHz

Mode	LTE Band 4, QPSK, CB:3 MHz, RB Size: 1 RB start: 0, index: 0, Channel: 19965						
Frequency (MHz)	Antenna Polarity	E.I.R.P (dBm)	Limit (dBm)	Margin (dB)	S.A Reading (dBm)	S.G Power Value (dBm)	Correction Factor (dB)
3421.02	H	-45.3	-13	-32.3	-56.06	-51.75	6.45
5131.53	H	-48.58	-13	-35.58	-64.26	-54.01	5.43
6842.04	H	-46.16	-13	-33.16	-64.82	-50.25	4.09
3421.02	V	-40.14	-13	-27.14	-50.89	-46.59	6.45
5131.53	V	-48.79	-13	-35.79	-64.25	-54.22	5.43
6842.04	V	-45.47	-13	-32.47	-64.11	-49.56	4.09

Note: EIRP = S.G Power value + Correction factor



Emissions below 1GHz

Mode	LTE Band 12, QPSK, CB:5 MHz, RB Size: 1 RB start: 0, index: 0, Channel: 23095						
Frequency (MHz)	Antenna Polarity	E.R.P (dBm)	Limit (dBm)	Margin (dB)	S.A Reading (dBm)	S.G Power Value (dBm)	Correction Factor (dB)
30.97	H	-71.04	-13	-58.04	-55.89	-49.64	-19.25
126.03	H	-76.27	-13	-63.27	-61.12	-67.72	-6.4
246.31	H	-74.25	-13	-61.25	-59.1	-70.64	-1.46
349.13	H	-76	-13	-63	-60.85	-72.62	-1.23
482.99	H	-73.22	-13	-60.22	-58.07	-69.62	-1.45
555.74	H	-72.11	-13	-59.11	-56.96	-68.51	-1.45
46.49	V	-62.99	-13	-49.99	-60.01	-44.09	-16.75
73.65	V	-67.41	-13	-54.41	-62.93	-55.87	-9.39
90.14	V	-65.98	-13	-52.98	-63.87	-58.9	-4.93
154.16	V	-67.3	-13	-54.3	-68.61	-58.58	-6.57
343.31	V	-73.73	-13	-60.73	-74.13	-70.34	-1.24
461.65	V	-70.27	-13	-57.27	-72.89	-66.65	-1.47

Note: ERP = S.G Power value + Correction factor-2.15 dB

Emissions above 1GHz

Mode	LTE Band 12, QPSK, CB:5 MHz, RB Size: 1 RB start: 0, index: 0, Channel: 23095						
Frequency (MHz)	Antenna Polarity	E.R.P (dBm)	Limit (dBm)	Margin (dB)	S.A Reading (dBm)	S.G Power Value (dBm)	Correction Factor (dB)
1413.04	H	-36.01	-13	-23.01	-38.56	-37.16	3.3
2119.56	H	-41.53	-13	-28.53	-46.89	-43.95	4.57
2826.08	H	-55.47	-13	-42.47	-63.04	-58.86	5.54
1413.04	V	-42.71	-13	-29.71	-45.29	-43.86	3.3
2119.56	V	-43.59	-13	-30.59	-49.04	-46.01	4.57
2826.08	V	-53.83	-13	-40.83	-61.55	-57.22	5.54

Note: ERP = S.G Power value + Correction factor-2.15 dB



## Emissions below 1GHz

Mode	LTE Band 13, QPSK, CB:5 MHz, RB Size: 1 RB start: 0, index: 0, Channel: 23230						
Frequency (MHz)	Antenna Polarity	E.R.P (dBm)	Limit (dBm)	Margin (dB)	S.A Reading (dBm)	S.G Power Value (dBm)	Correction Factor (dB)
69.77	H	-73.82	-13	-60.82	-69.18	-61	-10.67
433.52	H	-65.49	-13	-52.49	-65.6	-61.88	-1.46
473.29	H	-63.78	-13	-50.78	-64.88	-60.17	-1.46
684.75	H	-67.03	-13	-54.03	-71.62	-63.02	-1.86
753.62	H	-47.66	-13	-34.66	-56.01	-43.27	-2.24
796.3	H	-51.63	-13	-38.63	-57.7	-47.4	-2.08
48.43	V	-62.85	-13	-49.85	-59.97	-44.26	-16.44
90.14	V	-66.4	-13	-53.4	-64.29	-59.32	-4.93
127	V	-67.55	-13	-54.55	-68.12	-58.97	-6.43
473.29	V	-66.18	-13	-53.18	-68.89	-62.57	-1.46
769.14	V	-52.68	-13	-39.68	-60.48	-48.35	-2.18
796.3	V	-57.01	-13	-44.01	-65.26	-52.78	-2.08

Note: ERP = S.G Power value + Correction factor-2.15 dB

## Emissions above 1GHz

Mode	LTE Band 13, QPSK, CB:5 MHz, RB Size: 1 RB start: 0, index: 0, Channel: 23230						
Frequency (MHz)	Antenna Polarity	E.R.P (dBm)	Limit (dBm)	Margin (dB)	S.A Reading (dBm)	S.G Power Value (dBm)	Correction Factor (dB)
2339.79	H	-55.76	-13	-42.76	-61.77	-58.4	4.79
3119.72	H	-53.42	-13	-40.42	-61.7	-56.93	5.66
3899.65	H	-54.47	-13	-41.47	-64.69	-58.43	6.11
2339.79	V	-53.71	-13	-40.71	-60.02	-56.35	4.79
3119.72	V	-51.62	-13	-38.62	-59.93	-55.13	5.66
3899.65	V	-53.8	-13	-40.8	-64.12	-57.76	6.11

Note: ERP = S.G Power value + Correction factor-2.15 dB

## Emissions in the 1559-1610MHz band

Mode	LTE Band 13, QPSK, CB:5 MHz, RB Size: 1 RB start: 0, index: 0, Channel: 23230						
Frequency (MHz)	Antenna Polarity	E.I.R.P. (dBm)	Limit (dBm)	Margin (dB)	S.A Reading (dBm)	S.G Power Value (dBm)	Correction Factor (dB)
1559.86	H	-47.92	-40	-7.92	-52.23	-52.55	4.63
1559.86	V	-54.07	-40	-14.07	-58.61	-58.7	4.63

Note: EIRP = S.G Power value + Correction factor