



User Manual

Smart7 Pro™

Part #77-6800 CAN

Part #77-6801-A A2NA

Part #77-6811 CAN NP OHA

Part #77-6801-A A2SA

Part #77-6811 CAN WP OHA





Table of Contents

1. Introduction	2
2. Hardware Features	3
Solution Highlights	3
Powerful Cost Saving Tools	3
3. Technical Specifications	3
4. Mechanical Details	6
4.1 Top Dimensions	6
4.1 Side Dimensions	6
Federal Communication Commission Interference Statement	7
IMPORTANT NOTE: FCC Radiation Exposure Statement	7
Industry Canada Statement	8
Radiation Exposure Statement:	8
5. Company Information	9

1. INTRODUCTION

The Smart7 Pro™ 4G LTE Asset Tracking Gateway from Phillips Connect is a vehicle tracking device that combines GPS location with LTE and Bluetooth. Smart7 Pro monitors vehicle and asset functions and collects data for tracking and analysis.

The Smart7 Pro Gateway appears to the user of a server application as a single endpoint device. It can be queried, updated, and configured either through a serial connection or an over-the air (OTA) LTE IP connection. Smart7 Pro presents itself over the connections as an enhanced cellular modem with attached functional elements. These elements include:

- GPS location engine
- General Purpose Bidirectional I/O (GPIO) pins
- Relay drive pin output
- CAN Communication
- BLE 5.2 provides expandable sensor connectivity

The following is a typical application scenario:

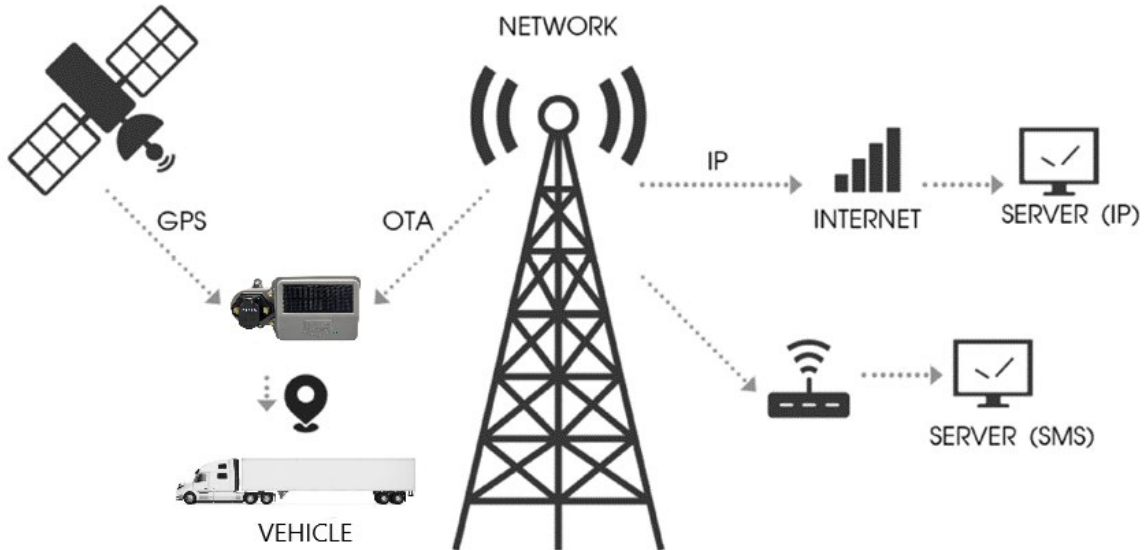



2. HARDWARE FEATURES

The Smart7 Pro Gateway ships from the factory pre-configured for a specific set of functions and can be configured and commissioned in the field, while providing support for external control through a Phillips Connect proprietary set of commands. Supported features include the following:

Solution Highlights

- Manage and view your assets in the cloud-based Remote Listening System
- Real-time visibility and simple geofencing
- Automated alerts configurable in the Remote Listening System
- Up to 6 months of reporting (on fully charged battery, stationary asset)
- Flawless operation in the harshest temperatures
- Configurable reporting when in motion
- 2 reports per day when parked (typical)

Powerful Cost Saving Tools

- Optimize trailer pool management
- Automate yard checks
- Covert installations help eliminate trailer theft and cargo loss
- Improve driver satisfaction
- Manage detention billing

3. TECHNICAL SPECIFICATIONS

CELLULAR SUPPORT

LTE-FDD: Bands B2/B4/B12

WCDMA: Bands B2/B4/B5

GLOBAL NAVIGATION SATELLITE SYSTEM (GNSS)

Supported Satellite Systems: GPS; GLONASS; BeiDou (COMPASS); Galileo; QZSS

Accuracy: Circular error probability (CEP-50) with Open Sky, <2.5 meters

Additional Features: Assisted GPS; WAAS Support

SENSOR DATA INTERFACES

Bluetooth 5.2

TIA-485-A

- Protocol: PCTBUS

CANBus 2.0B

- SAE J1939
- ISO 14229

GPIO: 1 Channel



ELECTRICAL / POWER MANAGEMENT

Operating Voltage: 10 V_{DC} – 32 V_{DC}

Power supply to sensors: 12V_{DC} / 500 mA

Peak current draw from tractor: 2 A @ 12 V_{DC}

- Battery charger draw: 1 A
- Sensor draw: 500 mA
- Telematics draw: 150 mA

Battery Type: Li-ion, rechargeable

- Nominal Capacity: 10.6 Ah
- Maximum Voltage: 4.2 V_{DC}
- Cell Cycle Life: ≥1000 cycles; ≥80% retention

Solar Panel I_{MP}: 0.36 A

Power management modes: Normal (Full power), Listen, Stealth

ENVIRONMENTAL

Ingress Protection Ratings: IP67; IP69K

Operating Temperature: -40°F to 149°F (-40°C to 65°C)

Storage Temperature: -40°F to 113°F (-40°C to 45°C)

Battery Charging Temperature: -4°F to 131°F (-20°C to +55°C)

Operating Humidity: 20% to 90% (non-condensing)

Storage Humidity: 10% to 95% (non-condensing)

MECHANICAL

Dimensions: 13.6" (L) x 7.0" (W) x 4.1" (H) (345 mm x 178 mm x 104 mm)

Weight: 5.31 lbs. (2.40 kg)

Mounting: 6 x 5/16" bolts

CERTIFICATIONS

FCC / IC

PTCRB Cellular



INTEGRATED: GATEWAY SENSORS

- Orientation
- Vibration
- Temperature
- Battery Voltage
- Solar Panel Current
- Primary Input Voltage
- Secondary Input Voltage
- GNSS Location
- GNSS Odometer
- Device Time via GNSS and NITZ

OPTIONAL BUILT-IN SENSORS

Light OutCheck™

Monitoring of all trailer lighting circuits during active use.

On-demand precheck of lighting circuits when tractor power is unavailable.

- Maximum lamp circuit voltage 20 V_{DC}
- Integrated resettable 5 A fuses (10 A on red circuit)
- Less than 100 mV insertion loss @ 5 A
- Maximum amperage detection 2 A
- PreCheck lighting circuits up to 1 A
- Amperage resolution 2 mA

ABS Fault CodeCheck™ *

Retrieved ABS data includes:

- Fault lamp status
- DTC trouble-codes (active & stored)
- ABS Odometer
- VIN (if programmed into ABS)

*Compatible with most ABS manufacturers

PreCheck™

Schedule-based or remote on-demand

- Lamp circuit supply: 11.5 V_{DC} / 1 A
- External sensor supply: 12 V_{DC} / 500 mA

4. MECHANICAL DETAILS

Top/Side dimensions are provided in inches.

4.1 TOP DIMENSIONS

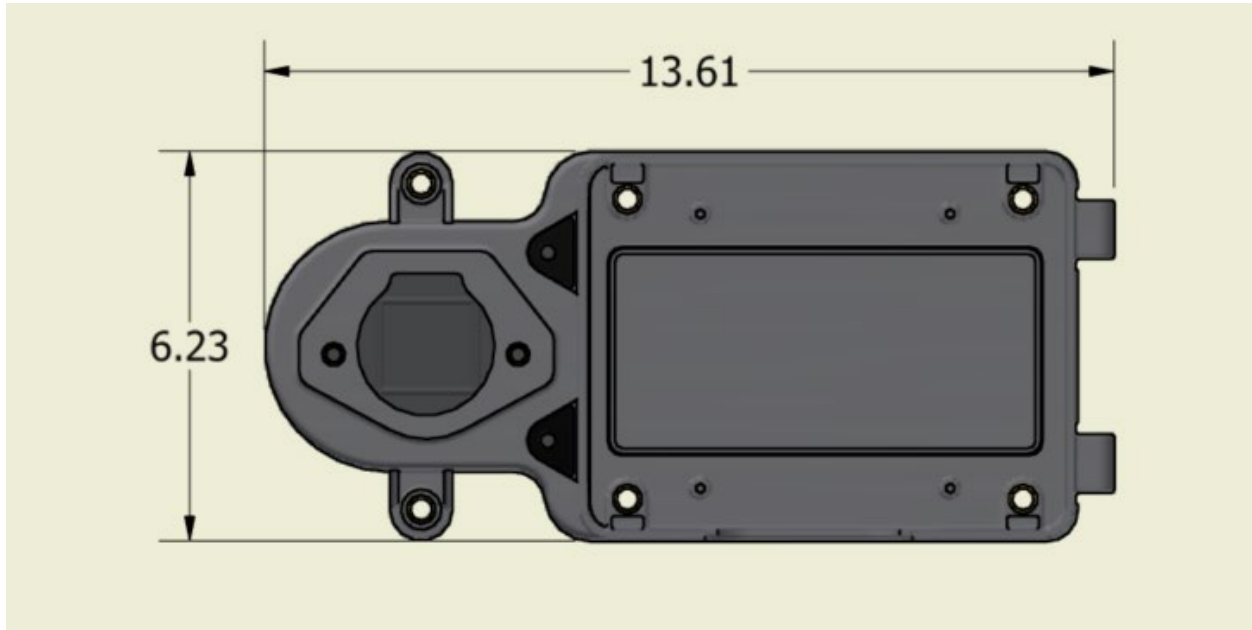

4.1 SIDE DIMENSIONS

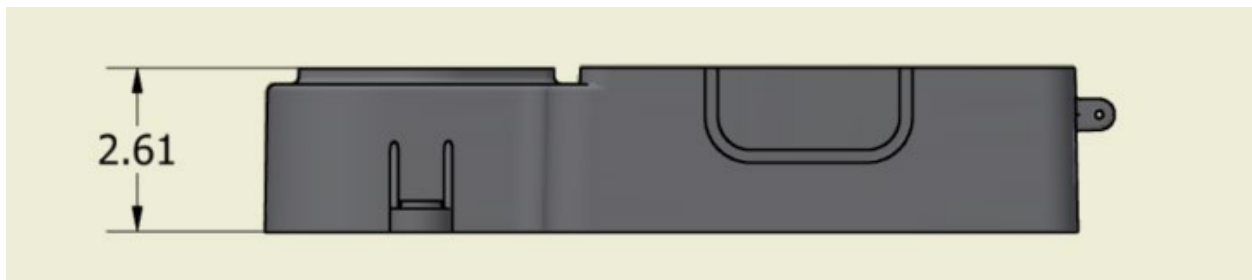



FEDERAL COMMUNICATION COMMISSION INTERFERENCE STATEMENT

This equipment has been tested and found to comply with the limits for a Class B digital device, pursuant to Part 15 of the FCC Rules. These limits are designed to provide reasonable protection against harmful interference in a residential installation. This equipment generates, uses, and can radiate radio frequency energy and, if not installed and used in accordance with the instructions, may cause harmful interference to radio communications. However, there is no guarantee that interference will not occur in a particular installation. If this equipment does cause harmful interference to radio or television reception, which can be determined by turning the equipment off and on, the user is encouraged to try to correct the interference by one of the following measures:

- Reorient or relocate the receiving antenna.
- Increase the separation between the equipment and receiver.
- Connect the equipment into an outlet on a circuit different from that to which the receiver is connected.
- Consult the dealer or an experienced radio/TV technician for help.

FCC Caution: Any changes or modifications not expressly approved by the party responsible for compliance could void the user's authority to operate this equipment.

This device complies with Part 15 of the FCC Rules. Operation is subject to the following two conditions: (1) This device may not cause harmful interference, and (2) this device must accept any interference received, including interference that may cause undesired operation.

IMPORTANT NOTE: FCC Radiation Exposure Statement

This equipment complies with the FCC radiation exposure limits set forth for an uncontrolled environment. This equipment should be installed and operated with minimum distance **20cm** between the radiator and your body.

The transmitter must not be co-located or operating in conjunction with any other antenna or transmitter.



INDUSTRY CANADA STATEMENT

This device contains license-exempt transmitter(s)/receiver(s) that comply with Innovation, Science and Economic Development Canada's license-exempt RSS(s). operation is subject to the following two conditions:

- (1) This device may not cause interference
- (2) This device must accept any interference, including interference that may cause undesired operation of the device.

L'émetteur/récepteur exempt de licence contenu dans le présent appareil est conforme aux CNR d'Innovation, Sciences et Développement économique Canada applicable aux appareils radio exempts de licence. L'exploitation est autorisée aux deux conditions suivantes:

- (1) L'appareil ne doit pas produire de brouillage;
- (2) L'appareil doit accepter tout brouillage radioélectrique sub, même si le brouillage est susceptible d'en compromettre le fonctionnement.

Radiation Exposure Statement:

This equipment complies with Canada radiation exposure limits set forth for an uncontrolled environment. This equipment should be installed and operated with minimum distance **20cm** between the radiator and your body.



5. COMPANY INFORMATION

**Technology that
moves us forward**



Phillips Connect Technologies LLC

*5231 California Ave. Suite 110
Irvine, CA 92617*

Technical Support

1-833-213-5839
Support@Phillips-Connect.com

Sales

1-833-213-5839
PCT-Sales@Phillips-Connect.com

COPYRIGHT NOTICE

© 2023 Phillips Connect Technologies LLC. All rights reserved.

Phillips Connect Technologies LLC reserves the right to modify the units, specification, or this document without prior notice in the interest of improving performance, reliability, or servicing. Reasonable efforts have been made to assure the accuracy of this document; however, Phillips Connect Technologies assumes no liability resulting from any inaccuracies or omissions in this document, or from use of the information herein. Product updates may result in differences between the information provided in this document and the product shipped. Please contact Phillips Connect Technologies LLC for access to the most current documentation.

No part of this document or information within this document may be copied, reproduced, distributed, merged, or modified without the express written consent of Phillips Connect Technologies LLC.