

ERP机型: PL5512Q-GL-SMT00011A-V1

ERP P/N:

描述:说明书:PL5512Q/PGK728WHK, SMT000,REV.A(MPGK728WHK240510),Size:165×165mm,  
105g双粉纸, 双面4C印刷, 过哑油, 14页28面,装订成本,RoHS2.0,REACH,Prop65,POPs,PAHs

C

M

Y

K

Diecut

PGK728WHK



Welcome to  
**Lockly Secure  
Pro**

Start Here

**LOCKLY**  
Enjoy the freedom™

# Table of Contents

---

Download the Lockly app	3	Using the PIN Genie Keypad	14
Scan for easy installation	4	Adding a Access Code	15
Installation overview	5	Unlock with Apple Home Keys	16
We are here to help!	6	Unlock with digital keypad	17
Getting to know your Lockly Secure Pro	7	Unlock with your finger	18
Install battery & setup with app	9	Auto and manual locking	19
Set up Apple Home	10	More ways to access and control	20
Fingerprint scanning	11	Alerts and Sounds	21
Adding a Fingerprint	12	Troubleshooting/FAQ	22
The PIN Genie Keypad	13		

# Download the Lockly app

---

Scan or visit [Lockly.com/app](https://lockly.com/app)

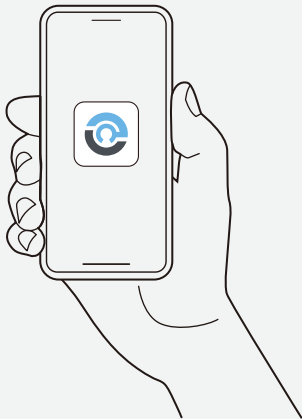

This app will guide you through the **installation** and **setup** process of your Lockly smart lock. **Create your profile** for a more tailored experience and optimised device performance and battery life.

# Scan for easy installation

---

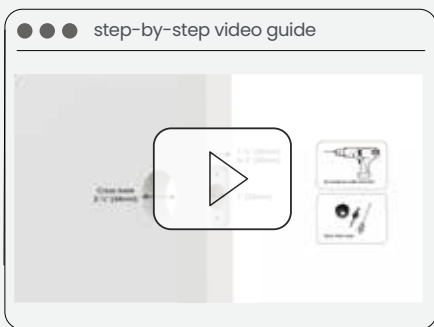

Watch our step-by-step video guide for easy installation and setup.

We will guide you through each step making it a breeze.

Installation guide included in the package. Check [support.Lockly.com](https://support.Lockly.com) for the most updated version.

# Installation overview

---

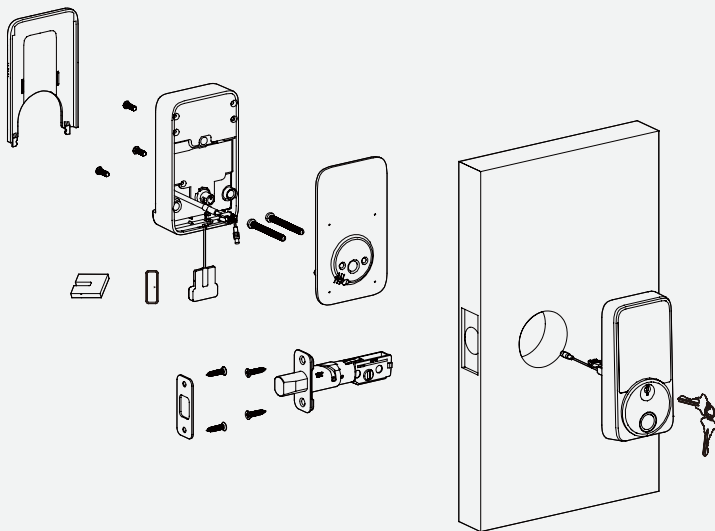

Installation  
Guide



User  
Manual

Scan for full Installation Guide and  
User Manual

# We are here to help!

---



Your Lockly smart lock comes with Lifetime technical support. Feel free to contact us with any questions or comments.

 **(669) 500-8835**

 **help@Lockly.com**

 **support.Lockly.com**

# Getting to know your Lockly Secure Pro

- a** Wi-Fi status
- b** Unlocked indicator / Welcome Mode
- c** Safe Mode
- d** Low battery indicator

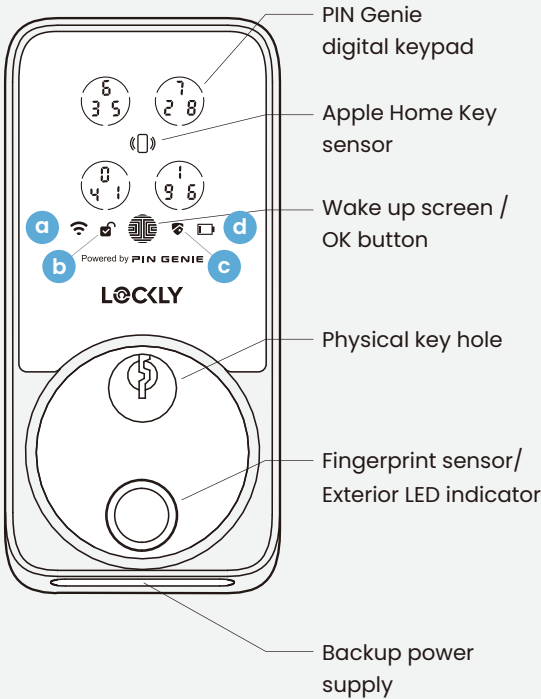

## Getting to know your Lockly Secure Pro

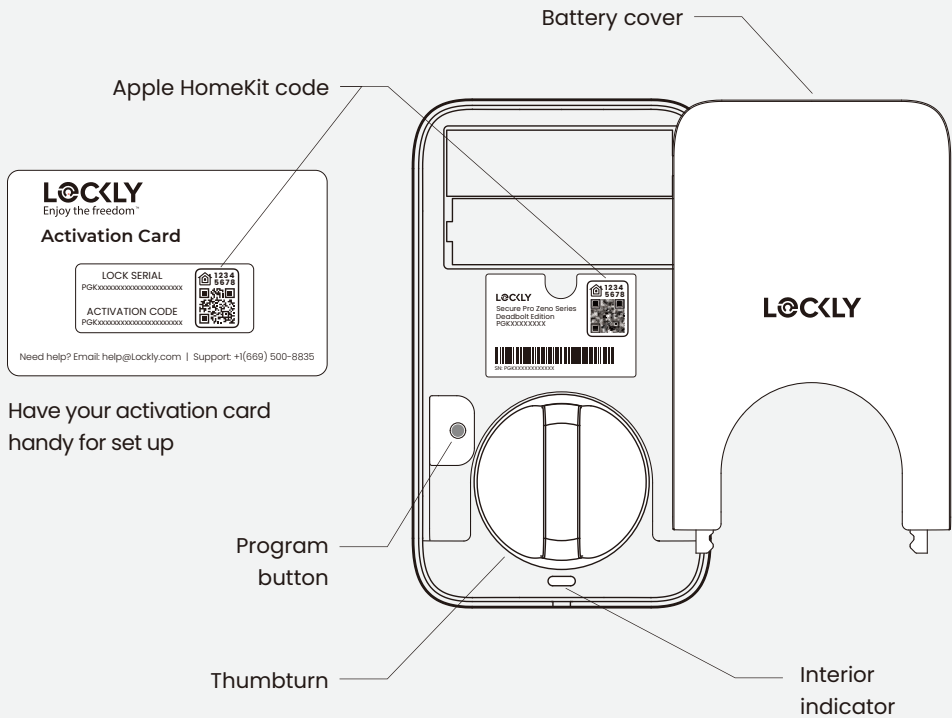



# Install battery & setup with app

---

## STEP 1

Insert 4 x AA batteries

## STEP 2

When powered, hold the Program button for 4 seconds, the lock will perform self diagnostics by extending and retracting the deadbolt multiple times.

## STEP 3

Open the Lockly app, tap on plus (+) to add a new device. Follow in-app instructions.

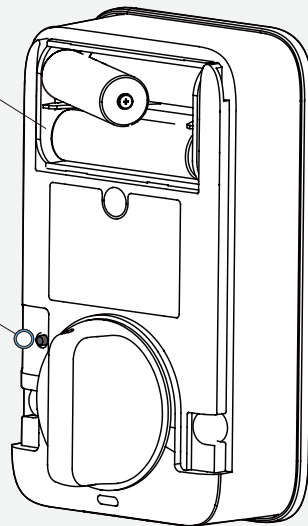

After the lock has been powered on for 10 minutes, the Bluetooth connection will be disabled and you cannot pair the lock with the Lockly app or Home app. To re-enter Pairing Mode, either reinstall the battery or press the Program button. Reactivating Bluetooth pairing can be done by tapping the 'BL' button on the keypad.

# Set up Apple Home



(Optional, iOS only)

Unlock your door with your iPhone and Apple Watch. Monitor status from your Home app.

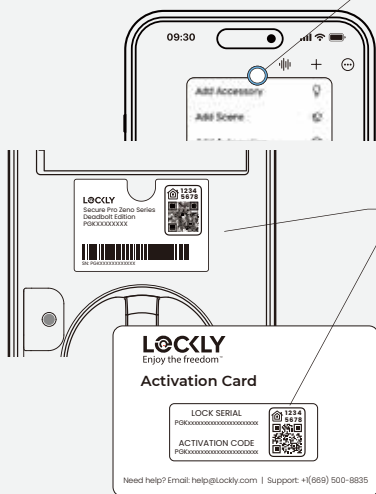

## STEP 1

Open Home app.

## STEP 2

Tap '+' in the upper right corner and select 'Add Accessory.'

## STEP 3

Remove the battery cover and locate the Apple HomeKit code in the interior assembly or on the activation card. Scan the code when prompted.

## STEP 4

Follow the in-app instructions to add your Home Key to your Wallet app.

### System requirements

Sharing access with others and controlling the Lockly Secure Pro away from home through Apple Home requires an Apple TV® (4th generation tvOS 12.0 or higher), an iPad® (iOS 12.0 or higher), a HomePod® or HomePod mini® setup as a home hub.

# Fingerprint scanning



To achieve consistent and quick fingerprint recognition, it's crucial to understand the correct procedure for registering fingerprints.

Place your fingertip flat on the sensor. Ensure it is centered.

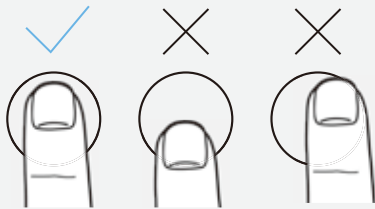

## Avoid Misalignment:

### Height:

Avoid positioning your finger too high or too low on the sensor.

### Left/Right:

Do not place your finger off-center to the left or right.



## Angle and Touch:

### Angle:

Keep your finger straight; avoid holding it at an angle.

# Adding a Fingerprint

Select your lock from the Lockly app.

Go to the 'Access tab' and follow on-screen instructions.

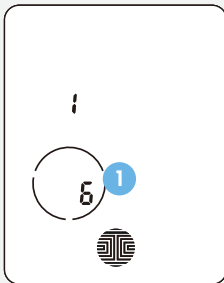

## STEP 1 - Fingerprint Scanning

- The sensor will scan each fingerprint multiple times, as shown by the countdown **1** on the screen.
- Lightly place your finger on the sensor until you hear a beep with the number counting down.

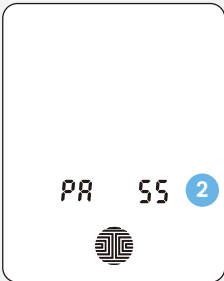

## STEP 2 - Lift and Repeat

- After each scan, lift your finger.
- Continue this process until you see the word "PASS" **2** on the screen accompanied by a long beep.

## STEP 3 - Repeat for Each Finger



If adding a fingerprint fails, return to the previous app menu to rescan.

# The PIN Genie Keypad



Our hack proof, exclusive PIN Genie™ dynamic shuffling technology shuffles access codes after each use.

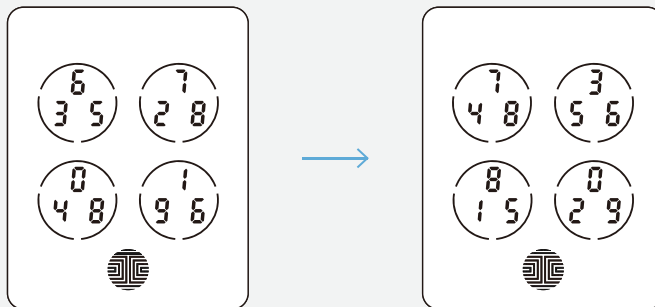

You can also toggle to a fixed keypad, refer to the Lockly app for more information.

# Using the PIN Genie Keypad

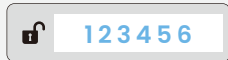

Default access code

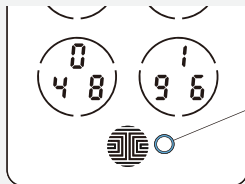
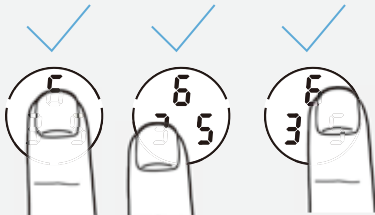
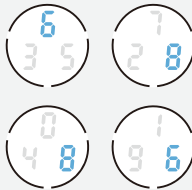

## STEP 1

Press the one of the four buttons that contain the digits of your access code.

Sometimes the same digit will appear in two buttons, **tab either button**.

**Press the button** where your number is shown. You do not need to press the actual number.

## STEP 2

Press the **OK button** when finish.

# Adding a Access Code

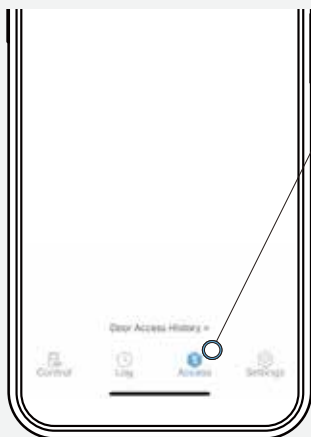

Select your lock from the Lockly app.

Go to the 'Access tab' and follow on-screen instructions.

The default access code is **1 2 3 4 5 6**.

During set up, you are required to set a new access code to replace the default access code.



You can set up via the Lockly app the valid period of your access codes - permanent, recurring or one-time use.

# Unlock with Apple Home Keys

## STEP 1

Add a home key to Apple Wallet with the Home app on your iPhone or Apple Watch.

Refer to page 10 for details.

## STEP 2

Turn on Express Mode in the Wallet app.



## STEP 3

Place your device near the  icon to unlock your door.

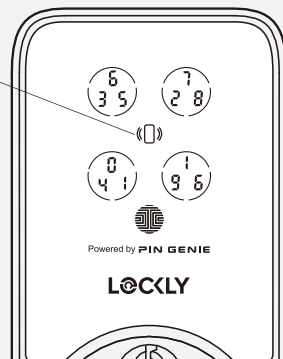



# Unlock with digital keypad

Our hack proof, exclusive PIN Genie™ dynamic shuffling technology shuffles access codes after each use.

## STEP 1

Press the circle button  to wake up the keypad.

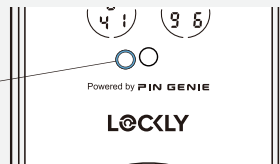

## STEP 2

Press the buttons that contain the digits of your access code.

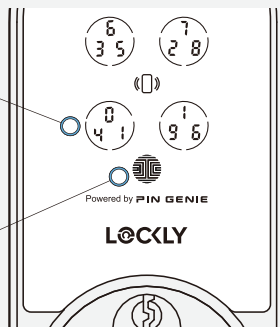

## STEP 3

Press the OK button.

Ten consecutive wrong attempts will put Lockly into "Safe Mode". Refer to [support.Lockly.com](https://support.Lockly.com) for details.



Temporarily boost the brightness of the keypad by pressing and holding any of the 4 buttons for 3 seconds.

# Unlock with your finger

---

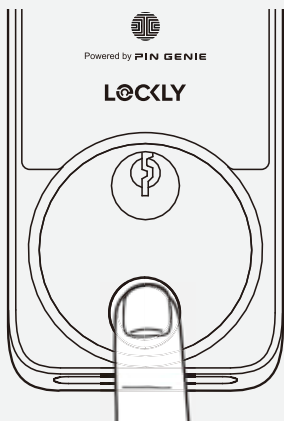

Place a registered finger flat and centered on the fingerprint sensor.

**Green LED with a 'beep' sound.**

Door is unlocked.

**Red Light with two 'beep' sounds.**

Finger is not recognized. Try again or use another registered finger.



Our advanced biometric sensor recognizes your fingerprint in 0.2 sec. With AI learning technology, it improves speed and accuracy over use.

# Auto and manual locking

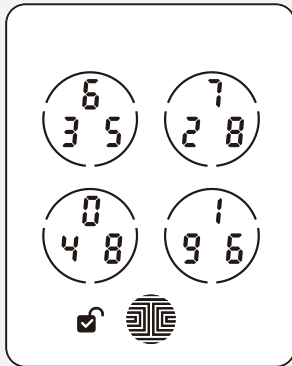

When the Lockly smart lock is unlocked, the  icon will display on the screen.

## Lock with Screen

Press the OK button  on the screen or swipe across when the screen is off.

## Auto-Lock

Set up auto-lock when you close your door in the Lockly app.

## Thumbturn

Rotate the thumbturn on the interior assembly.

## Physical Key

Insert physical key and rotate.



When the Lockly smart lock is unlocked, the unlocked  icon will display on the screen.

# More ways to access and control

Lockly smart lock offers a wide range of secured ways to access and grant access to your property. Refer to the Lockly app to learn more or visit [support.Lockly.com](https://support.Lockly.com).



## eKeys & eBadges

Revocable access (permanent, recurring or one-time) to unlock, or setup sub-admin to let others help you manage your property.



## Offline Access Codes™

Grant access even if your internet is down. Issue one-time access via Lockly app.



## Welcome Mode

Disable auto-lock according your preset schedule for instant access.



## Voice Control

Setup Alexa and Google Assistant to control and monitor your lock status.



## Air Transfer

Easily transfer user profiles between Lockly device for seamless setup and access management.



## LocklyOS

Managing multiple properties with dashboards, reports exporting, email templates and many more.



We bring several new features to our smart locks every year.

Subscribe to our newsletter to receive latest product updates, expert tips and stay updated with our latest innovations.

# Alerts and Sounds

## Exterior Assembly Alerts

### Fingerpint

**Exterior LED indicator flashes green with a 'beep' sound**

Door unlocked

**Exterior LED indicator flashes red with two 'beep' sounds**

Fingerprint recognition failed

### Access Code

**Exterior LED indicator flashes green**

Door unlocked

**Exterior LED indicator flashes red**

Incorrect access code entered

### Apple Home Key / Voice Control

**Exterior LED indicator flashes green**

Door unlocked

## Interior Assembly Alerts

### Battery

**Interior LED indicator flashes red with a beep sound (x3)**

Battery level is less than 20%



**Interior LED indicator flashes red with a beep sound (x5)**

Battery level is critically low (3 unlocks remaining). Replace battery immediately.

# Troubleshooting / FAQ

---

## Why is my keypad not responding?

- Press the circle button  to activate the keypad.
- If  is flashing, your smart lock is in **Safe Mode**. Unlock with other access credentials (fingerprint, mobile app, home key or physical key) to exit.
- If water is detected, **Rain Mode** may be activated. Unlock your door with other authentication methods (Apple Home Keys, Lockly app..)
- Check if batteries are installed correctly.
- Refer to [support.Lockly.com](https://support.Lockly.com) for more information about **Safe Mode** and **Rain Mode**.

## Why is my keypad on full blackout?

- Battery may have been completely depleted. Use the physical key or a Type-C cable to connect your Lockly to a mobile power source to temporary activate the lock. Replace the battery immediately after unlock.

## Why is my fingerprint not recognized?

- Check that you are using a registered finger.
- Make sure your finger is clean and dry.
- Position your finger at the centre of the sensor.

## Why is my Lockly not locked automatically?

- Check if auto lock is disabled in the Lockly app.
- **Welcome mode** is currently active. Disable or change setting in Lockly app.

### **How to pair my smart lock with a new phone?**

- Download the Lockly app on your new device and log in using the same account credentials, follow in-app instructions.

### **How to pair my smart lock with a new Lockly account?**

- You will need to perform a factory reset with the following steps.
  1. On the old Lockly app account, go to Settings > Reset and Pairing > Perform Factory Reset
  2. Download, register and log in to the new Lockly app account. You will need your activation card to set up the device.
- You can perform factory reset on the lock. Refer to Lockly app or [support.Lockly.com](https://support.Lockly.com) for more details.

### **Lockly Technical Support**

(669) 500-8835

[help@Lockly.com](mailto:help@Lockly.com)

[support.Lockly.com](https://support.Lockly.com)

**FCC Warning:**

This device complies with Part 15 of the FCC Rules. Operation is subject to the following two conditions: (1) This device may not cause harmful interference, and (2) this device must accept any interference received, including interference that may cause undesired operation.

NOTE 1: This equipment has been tested and found to comply with the limits for a Class B digital device, pursuant to part 15 of the FCC Rules. These limits are designed to provide reasonable protection against harmful interference in a residential installation. This equipment generates, uses and can radiate radio frequency energy and, if not installed and used in accordance with the instructions, may cause harmful interference to radio communications. However, there is no guarantee that interference will not occur in a particular installation. If this equipment does cause harmful interference to radio or television reception, which can be determined by turning the equipment off and on, the user is encouraged to try to correct the interference by one or more of the following measures:

- Reorient or relocate the receiving antenna.
- Increase the separation between the equipment and receiver.
- Connect the equipment into an outlet on a circuit different from that to which the receiver is connected.
- Consult the dealer or an experienced radio/TV technician for help.

NOTE 2: Any changes or modifications to this unit not expressly approved by the party responsible for compliance could void the user's authority to operate the equipment.

**FCC Radiation Exposure Statement**

This equipment complies with FCC radiation exposure limits set forth for an uncontrolled environment. It should be installed and operated with minimum distance 20cm between the radiator & your body.

**IC WARNING**

This device contains licence-exempt transmitter(s) that comply with Innovation, Science and Economic Development Canada's licence-exempt RSS(s). Operation is subject to the following two conditions:

- (1) This device may not cause interference.
- (2) This device must accept any interference, including interference that may cause undesired operation of the device.

L'émetteur/récepteur exempt de licence contenu dans le présent appareil est conforme aux CNR d'Innovation, Sciences et Développement économique Canada applicables aux appareils radio exempts de licence. L'exploitation est autorisée aux deux conditions suivantes:

1. L'appareil ne doit pas produire de brouillage;
2. L'appareil doit accepter tout brouillage radioélectrique subi, même si le brouillage est susceptible d'en compromettre le fonctionnement.



### **IC Radiation Exposure Statement**

This equipment meets the exemption from the routine evaluation limits in section 2.5 of RSS-102. It should be installed and operated with a minimum distance of 20cm between the radiator and any part of your body.

Cet équipement est conforme à l'exemption des limites d'évaluation habituelle de la section 2.5 de la norme RSS-102. Il doit être installé et utilisé à une distance minimale de 20 cm entre le radiateur et toute partie de votre corps.



**WARNING:** This product can expose you to chemicals including Lead, which is known to the State of California to cause cancer. For more information go to [www.P65Warnings.ca.gov](http://www.P65Warnings.ca.gov).

## Let's co-create!

Have an innovative idea?  
Facing an inconvenient situation?

(669) 500-883  
hello@Lockly.com

**LOCKLY**  
Enjoy the freedom™

## Own a business?

Learn about how LocklyPRO and LocklyOS  
can help you in your business.

(510) 288 9928  
prosales@Lockly.com

© Copyright 2024 Lockly All rights reserved

US Patent No. US 9,881,146 B2 | US Patent No. US 9,853,815 B2 | US Patent No. US 9,875,350 B2 | US Patent No. US 9,665,706 B2 | US Patent No. US 11,010,463 B2 | AU Patent No. 2013403169 | AU Patent No. 2014391959 | AU Patent No. 2016412123 | UK Patent No. EP3059689B1 | UK Patent No. EP3176722B1 | patternity technology patterned or parents and pattern pending

Use of the Works with Apple badge means that an accessory has been designed to work specifically with the technology identified in the badge and has been certified by the developer to meet Apple performance standards. Apple is not responsible for the operation of this device or its compliance with safety and regulatory standards.

The Bluetooth® word mark and logos are registered trademarks owned by the Bluetooth SIG, Inc., and any use of such marks by Lockly is under license. Other trademarks and trade names are those of their respective owners. Google, Android, Google Play and Google Home are trademarks of Google LLC., Amazon, Alexa and all related logos are trademarks of Amazon.com, Inc., or its affiliates.

Apple, Apple Home, Apple Watch, HomeKit, HomePod, HomePod mini, iPad, iPad Air, iPhone, and tvOS are trademarks of Apple Inc., registered in the U.S. and other countries and regions.

MPGK728WHK240510