

ERP机型 : PL35M1UQ-GL-SMT00010A-V2

ERP P/N :

描述: 说明书 (智能锁体) :PL35M1UQ/PGD798NV,SMT000,REV.B(UMPGD798NV20220510),
196×196MM,封面&底面:128g双粉纸双面过哑油,双面印4C+2专,内页80g书纸,双面印单黑,
20页40面装订本,RoHS2.0,REACH,Prop65,POPs,PAHs

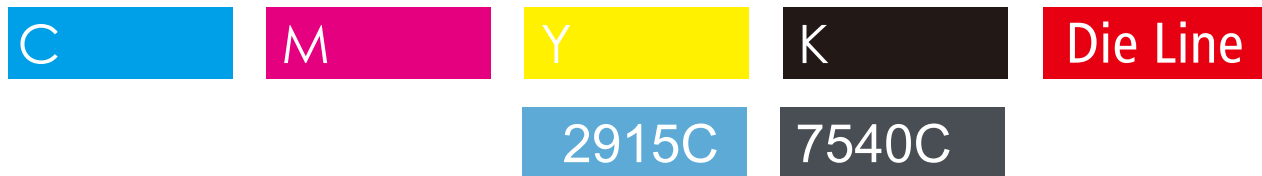

Designed : Sabrina

Date : 2022-05-10

封面

LOCKLY VISION™ ELITE

SMART LOCK + VIDEO DOORBELL



USER MANUAL

DEADBOLT EDITION

Table of Contents

Section 1 - Product Highlights

1.1	Product Features	1
-----	------------------	---

Section 2 - Product Overview

2.1	Product Overview - Outside	3
2.2	Product Overview - Inside	4
2.3	Understanding Your New Lock	5
2.4	Keypad Display Switch	6
2.5	Reset Button	6
2.6	Rebooting Your Lock	7
2.7	Low Battery	8
2.8	Enhanced Solar Charging	9

Section 3 - Using Your Smart Lock

3.1	Configuring Access	10
3.2	Adding a Fingerprint	11
3.3	Fingerprint Scanning Directions	12
3.4	Fingerprint Scanning Tips & Troubleshoot	13

Section 4 - Locking and Unlocking

4.1	Unlocking using Access Codes	14
4.2	Unlocking with Fingerprints	15
4.3	Locking/Unlocking with Physical Key	16
4.4	Locking/Unlocking with App	17
4.5	Locking/Unlocking with Voice Assistants	18
4.6	Safe Mode	19
4.7	Rain Mode	21
4.8	Shine Mode	22
4.9	Welcome Mode	22

Section 5- Advanced Features

5.1	Video Doorbell	23
5.2	Night Vision	27
5.3	Loitering Alert	28
5.4	Offline Access Code™ (OAC)	29
5.5	Sub-Admin Access	30

Section 6 - Re-keying

6.1	Re-keying	30
-----	-----------	----

Section 7 - Important Notes

7.1	Important Notes	31
-----	-----------------	----

Section 8 - Cleaning

8.1	Cleaning	32
-----	----------	----

Section 9 - Safety Precautions

9.1	Safety Precautions	33
-----	--------------------	----

For additional support,
visit <http://Lockly.com/help> or email
help@Lockly.com



1.1 Product Features

Video Monitoring and Recording

Full HD video camera streaming directly to your smartphone in real-time, gives a head to toe 130° view angle of who's at your front door. Video recordings are stored locally with no monthly fees.

Night Vision IR & Enhanced Motion Detection All day and night, get notified with enhanced motion detection with what is happening outside up to 13 feet (4 meters) distance and clearly see images with an infrared night vision activated in the dark.

Patented Peek-Proof PIN Genie Keypad

Digits are randomly displayed on the keypad ensuring access codes to be undetectable to intruders after repeated use. Numbers are randomly distributed across 4 buttons, with 3 numbers in each button. Users can press any button showing their number. Location of the numbers are always different everytime someone uses the keypad, making it hard for prying eyes to guess the correct code.

Multiple Access Codes & Monitoring

Store up to 33 Access Codes for family, friends and guests, as well as monitor entry and exit records.

Advanced 3D Fingerprint Recognition

Biometric Fingerprint Recognition protocol allows up to 99 registered fingerprints to be used and accepts only actual fingerprints - preventing lifted prints from being used.

Live Monitoring and Voice Control

Through your smartphone, monitor door access from anywhere in the world and securely control who comes and goes. You can also control your Lockly smart lock using voice with your Amazon Alexa or Google Assistant-enabled devices.

Complete Privacy

The exterior displayed keypad can be locked and switched off using the simple ON/OFF toggle from the inside panel. The owner can prevent others trying to input the passcode from the outside and entering the home

Offline Access Code™ (OAC)

The offline access code can allow owners to issue access codes, set the allowed access duration, all without Lockly ever connecting to the internet, so in case of power outage, you can still magically and remotely issue Access Codes without any connection to the web.

Auto-Lock, Tamper Proof Keyhole and Backup Keys

The door can be opened with physical backup keys. Receive notification whenever there's an attempt to tamper your lock. Worry no more about forgetting to lock the door. With Auto Lock enabled, Lockly will automatically auto-lock the door based on your customized timing set between 5-300 seconds.

Solar Panel & Lithium Battery Power

Integrated with solar panel for auto trickle charging lithium battery. Micro USB charging port available for areas without adequate sunlight.

2.1 Product Overview- Exterior

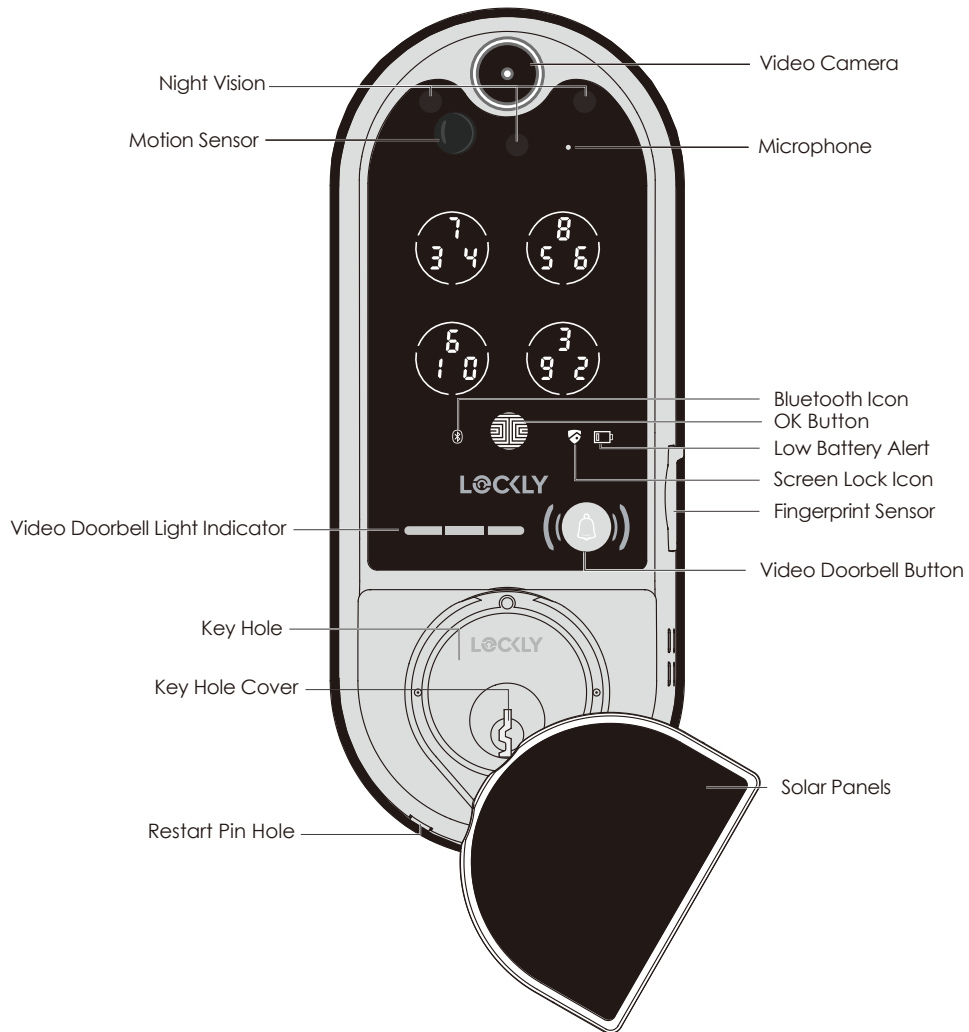

2.2 Product Overview - Inside

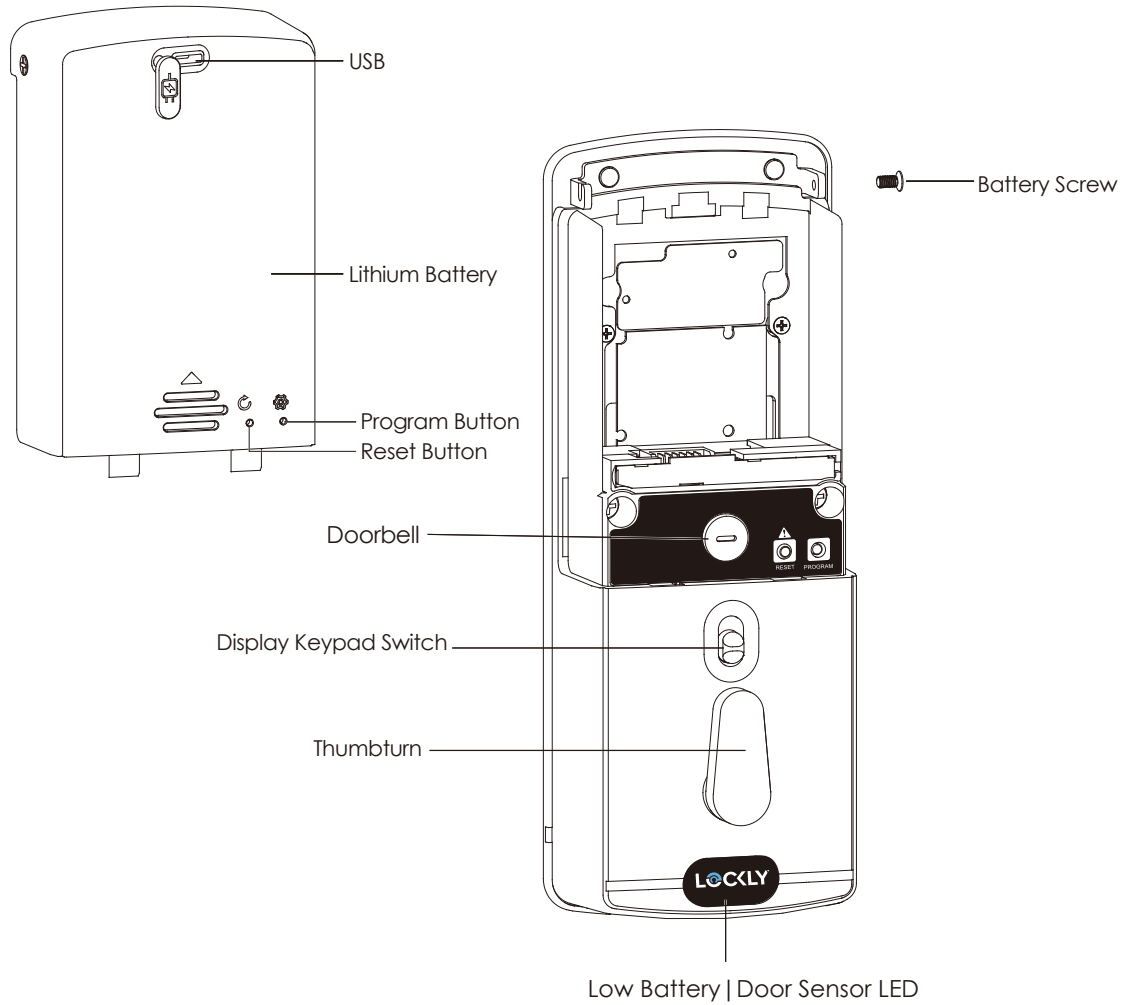

2.3 Understanding Your New Lock

After the installation of your new Lockly Vision™ Elite, understanding some key functions of operating your smart lock is important. The next sections will walk you through configuring Access Codes, adding fingerprints, video doorbell recording, resetting, pairing, configuring your Offline Access Code™ (OAC) and other features of your lock.

For any questions you can always visit <http://Lockly.com/help> for assistance.

Don't forget that in order for Lockly Vision™ Elite to work with full features, it is required to pair it with the Lockly App available for both iOS and Android™ smart devices. Please download the app by visiting the link below.



Scan or visit Lockly.com/app

2.4 Keypad Display Switch

For your peace of mind, the exterior keypad screen can be locked and turned off by using the **ON/OFF** switch at the back panel (**PART G**) of the smart lock. When it is switched off, people who are outside cannot enter any access codes to unlock the door.

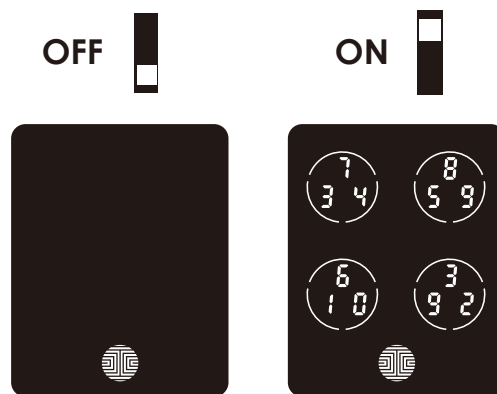

2.5 Reset Button

In order to setup the Lockly to another smart phone, you must have your "Activation Code" available. The Activation Code can be found on the Activation Code Card (PART V) that came with your smart lock.

Press **Reset Button** for one (1) second or till you hear a short beep

Open the Lockly **smartphone app** to add your lock using the **Activation Code**

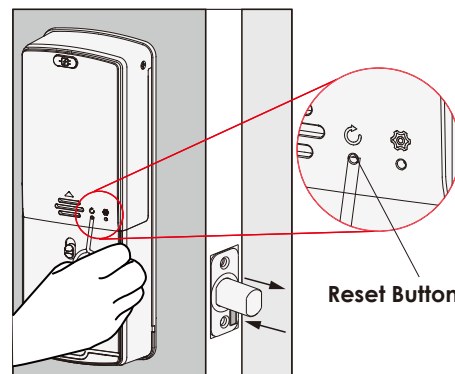

2.6 Rebooting Your Lock



NOTICE

Reboot Lockly in case of dead battery or malfunction. No settings will be changed and all Access Codes will still be stored within Lockly.

Press and release the reboot button when you want to reboot the lock. Your Lockly will beep once after reboot. Only reboot when necessary.

To reboot, find the reboot button located on the bottom of the exterior side of Lockly lock. The reboot button is located in the middle of the two 9V battery backup sockets.

You will need something small such as a paperclip, to press the reboot button. Insert the paperclip and press down firmly and let go. Your screen should restart and the lock should reboot automatically.

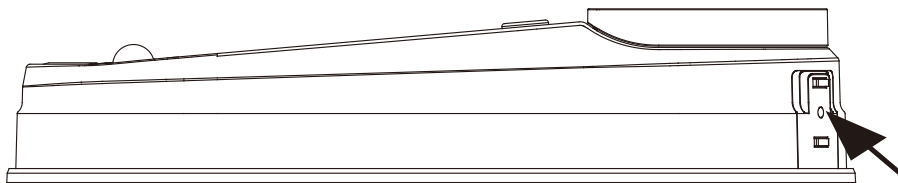

Reboot Button

2.7 Low Battery

The built-in solar panel trickle charges with an ideal sunlight source and should prolong battery life. If sunlight is not enough and continues to fall below optimum level, battery icon on the touchscreen will light up to indicate low battery. Immediately replace with backup lithium battery to avoid smart lock from shutting down. To ensure the door lock continuous to work, follow below:

- Remove the battery with insufficient power and replace it with a fully charged spare battery.
- Use the power adapter or power bank to connect the battery through the USB cable to charge.

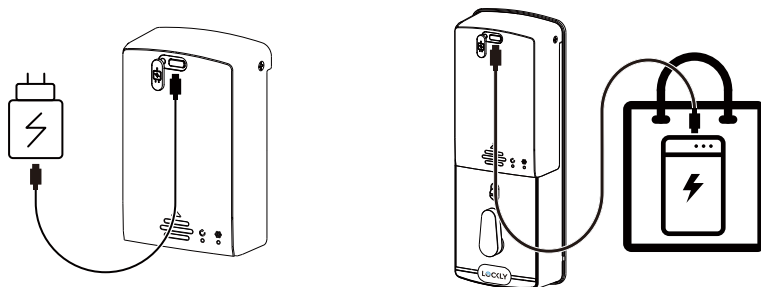

IMPORTANT: When the battery is lower than 20%, the motion sensing recording function will be disabled, and the video doorbell function will be disabled when the battery is lower than 5%. You can check the real-time battery level of the door lock through the Lockly App.

When there is no display, sound and screen is non-functional, replace batteries immediately. Use supplied physical backup keys to unlock the door. Alternatively, use a 9V battery as shown below to temporarily activate the lock.

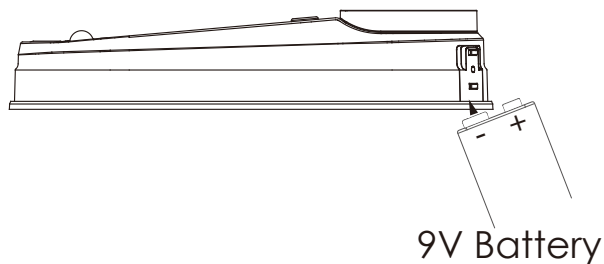

Your Lockly will automatically detect battery polarity. So hold your 9V battery lead in place against bottom of the Lockly to **temporarily** activate the screen to enter your **Access Code**. Be sure to hold the 9V battery against the contact points located at the bottom of the lock until you have successfully unlocked your door with your **Access Code**. Once unlocked, batteries should be replaced immediately.

2.8 Enhanced Solar Charging

Lockly Vision Elite is equipped with solar panels which auto trickle charges the lock's battery. Having an ideal sunlight source , the solar panel charges the battery to keep it at optimal charge level to around 50-80%. Keeping the battery at this optimal level prolongs battery life.

Solar panel lasts up to 3-5years depending on usage and care. In order to keep the solar panel at its the best condition, please clean the surface regularly and do not squeeze the solar panel too hard.

Once you noticed that you're battery level keeps to fall below optimal level despite sufficient sunlight or ambient light, charging the lithium battery via USB cable or changing the solar panel is recommended. You may reach our online support at: [Lockly.com/support](https://lockly.com/support) or call (669) 500-8835to order a new solar panel.

3.1 Configuring Access



Pair your lock to your smart phone to manage your access codes. Follow the on screen instructions to complete the setup.

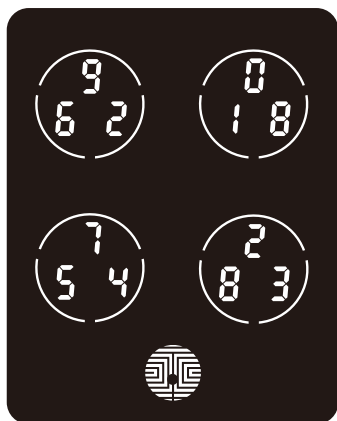

OK Button

There are a total of **five (5) buttons** on the keypad as shown in the example image to the left. The numbers in each button may differ than what is shown on your device than what is displayed here.

To enter your required digit, just simply press the circle where your number is shown. You do not need to press the actual number as anywhere within the circle will suffice.

The button on the bottom is the **OK** button. You will be pressing this button when you are done entering your **Access Code**.



NOTICE

The Default Access Code is **1 2 3 4 5 6**

Your new Lockly **Access Code** can be any combination of **6 to 8 digits**. Once a new Access Code is entered, the **Default Access Code** of **123456** would be deleted. A maximum of 33 sets of Access Codes can be stored for use at any given time. To add more than 33 sets of Access Codes, you must delete an existing Access Code before adding a new code.

There are different types of Access Codes that can be generated using the Lockly App. Each type of access code have different levels of permission you can select for your guests, tenants, deliveries, helpers, etc., Get the latest updates on access codes, visit: www.support.lockly.com/faq/accesscodes/

3.2 Adding a Fingerprint



NOTICE

Please make sure your fingers are clean from dirt and oils before scanning your fingerprint. Make sure the sensor is also clean by taking a soft cloth and wiping the surface.

We are using an advanced biometric sensor, providing the most secure fingerprint authentication. Your smart lock can register up to ninety-nine (99) fingerprints. Use the Lockly app to add fingerprints.

Scan your finger by lightly placing your designated finger on the sensor until you hear a beep. Lift your finger and repeat the process slowly until the digit “6” shown on the screen becomes “1”. If you have successfully scanned and registered your fingerprint, you will hear a long beep, and the video doorbell light indicator will blink green.

PASS will show on the keypad and press **OK Button** to exit. If you did not successfully register your fingerprint, **FAIL** will show on the keypad. If FAIL is displayed, return to the previous menu and rescan your finger.

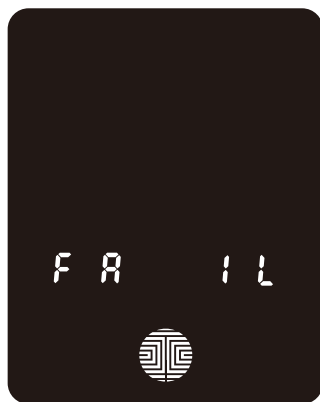

OK Button



3.3 Fingerprint Scanning Directions

The **fingerprint sensor** equipped in your smart lock is loaded with powerful fingerprint algorithms to extract only metadata from fingers, even in poor conditions. Placing your finger on the sensor correctly helps consistency in fingerprint recognition. The following directions and tips will guide you on how to scan an optimal fingerprint image.

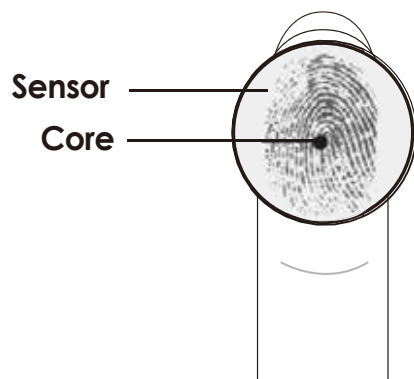
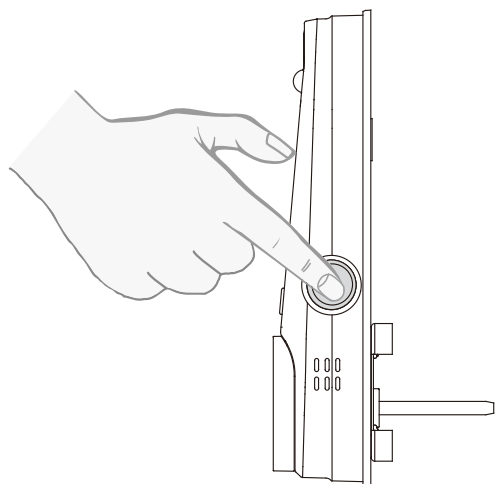

Position your finger on the **center** of the sensor

Top View

OK

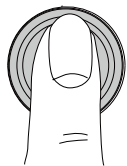

X

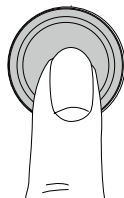

X

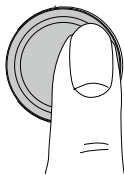

o Correct

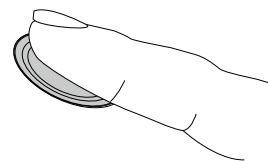
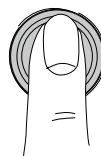

o Incorrect

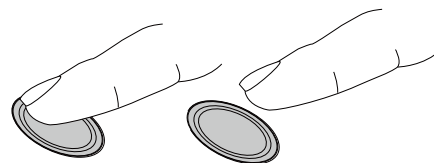
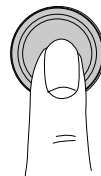

Side View

OK



X

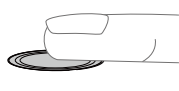

X

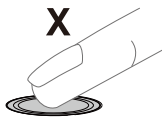

3.4 Fingerprint Scanning Tips & Troubleshoot

Tips for Fingerprint Enrollment and Recognition

- Place your finger to completely cover the sensor with maximum contact surface.
- Position the center of your finger (core) to the center of the sensor.
- Hold your finger still for more than a second until you hear a beep.
- Scan a finger that is clean and free from dirt.
- Children ages 12 and under are not recommended to use fingerprint access due to the constant changes of their fingers during growth.
- Elderly with fading fingerprints may have difficulty in recognition.
- If your finger has a cut, scar, or cracked skin due to dryness, try another finger.

Troubleshooting Fingerprints

In case of poor fingerprint conditions

- If wet - wipe excess moisture from finger before scanning
- If dirty - wipe stains and dirt off from finger before scanning
- Make sure the sensor is clean from dirt or smudges - wipe sensor with soft cloth regularly

For more troubleshooting help, visit <http://Lockly.com/help>

4.1 Unlocking with Access Codes

Lockly Smart Lock can be unlocked using multiple ways - via your stored Access Code, registered fingerprint, smartphone with Bluetooth, the physical key supplied with your lock, or voice.



Slide your hand across the screen to activate the keypad.

Enter your **6 to 8 digit Access Code** followed by the **OK** button. Press **OK** anytime to reset if you entered the wrong digit.

If the **Access Code** entered is correct, the door will unlock. If the **Access Code** entered is incorrect, Lockly will **flash red light**.



Three consecutive wrong attempts will put Lockly in "Safe Mode". (See Section 4.6)

Lock your Lockly by pressing the **OK Button**, by brushing your hand across the screen anytime or via Lockly app when the door is closed. The smart lock will also auto-lock after unlocking based on your set auto-lock settings.

You may toggle between two types of keypad displays to enter your **Access Code**. The **fixed digit** version and the **PIN Genie** version (Recommended). Press and hold the **OK Button** for 3 seconds to toggle back and forth between the two keypads. *(Sample display shown only)*

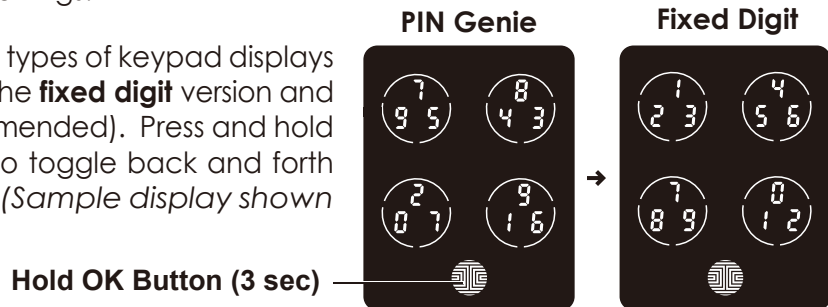

4.2 Unlocking with Fingerprints

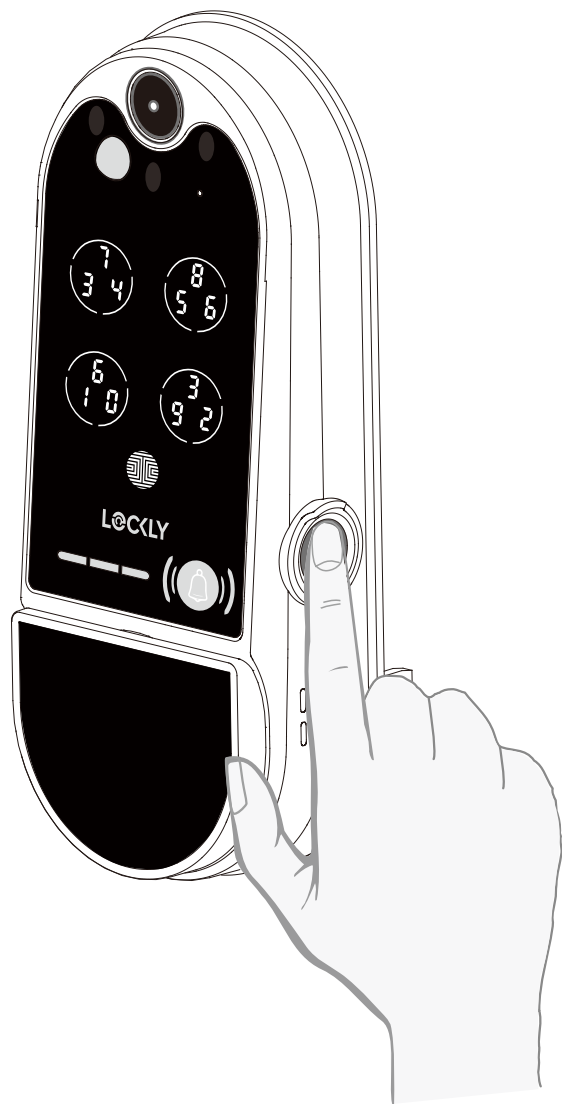

Unlocking

Place a registered finger to the **fingerprint scanner** located on the **exterior side** of the lock to the right.

To register a **fingerprint**, please see **Section 3.2**.

If your fingerprint is **registered** and acknowledged, you will hear a “beep” sound and a **Green LED** will light up on the **fingerprint scanner**. You can then open the door.

If you see a **Red LED**, it means your fingerprint is not recognized. You must wait until the red LED is off to try again.

For best fingerprint scanning practices, see **Section 3.3**.

4.3 Locking/Unlocking with Physical Key

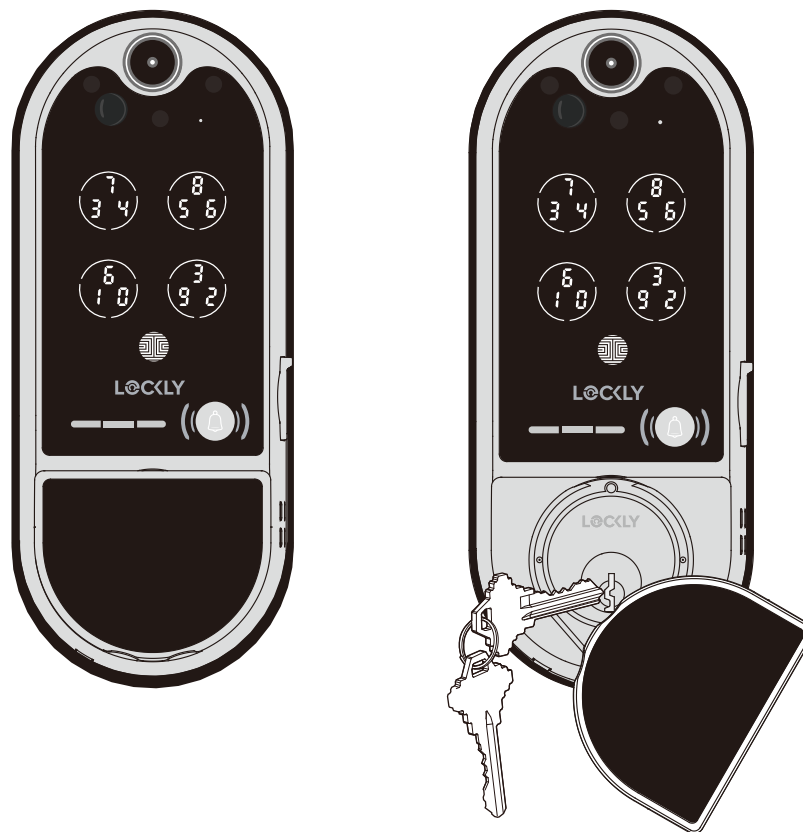

Exterior View

We presumed you will not be using the key on a regular basis. To better protect you from malicious lock bumping, video will start recording whenever a key or bumping devices are used to unlock the door.

To unlock your lock using the physical key (included), gently tilt and rotate the solar panel on either left or right direction to reveal the keyhole. Insert the key and turn clockwise to unlock the door. Again, this will trigger the video recording.

4.4 Locking/Unlocking with App

You must have the Lockly iOS or Android™ app installed in order to lock and unlock with smartphone, connect with voice assistants like Alexa or Hey Google and to access video doorbell feature. Please download the app by visiting the link below or search “Lockly” from the correct app store.

Scan or visit
[Lockly.com/app](https://lockly.com/app)



4.5 Locking/Unlocking with Voice Assistants

Once your Lockly Vision™ Elite and Vision Connect has been installed and configured correctly, make sure you enable the Lockly Action on Google or the Amazon Alexa Skill before you can configure your voice to perform voice commands.

You can ask your questions such as door status or request for your door to be locked or unlocked.



- "Hey Google, unlock the Back Door"
- "Hey Google, is the Back Door locked?"
- "Hey Google, lock the Back Door"
- "Hey Google, is the Back Door unlocked?"

Pre-setup is required in the Google Home app in order for these queries to work. The user would need to name the lock "Back Door" or as appropriate.





- Alexa, unlock my Front Door.*
- Alexa, is my Front Door locked?
- Hi Alexa, lock my Front Door.
- Alexa, is my Front Door unlocked?

*Unlock requests will require additional voice security codes.
You may configure it in the settings page.

Google, Android, Google Play and Google Home are trademarks of Google LLC.

4.6 Safe Mode - Overview

Lockly will enter **Safe Mode** when three (3) consecutive wrong **Access Codes** are entered within 5 minutes. A 15 second video will be recorded once the lock entered into Safe Mode. When in **Safe Mode**, the lock status icon  will start to flash.

To disable **Safe Mode**, you must unlock the door using the correct fingerprint or enter the correct **Access Code** twice in a row. Activate the keypad by pressing and holding  for 3 seconds.

Once the screen is activated, enter the correct **Access Code** carefully twice, pressing  after every time.

If you enter the wrong code, the keypad will then be disabled for **10 minutes**.

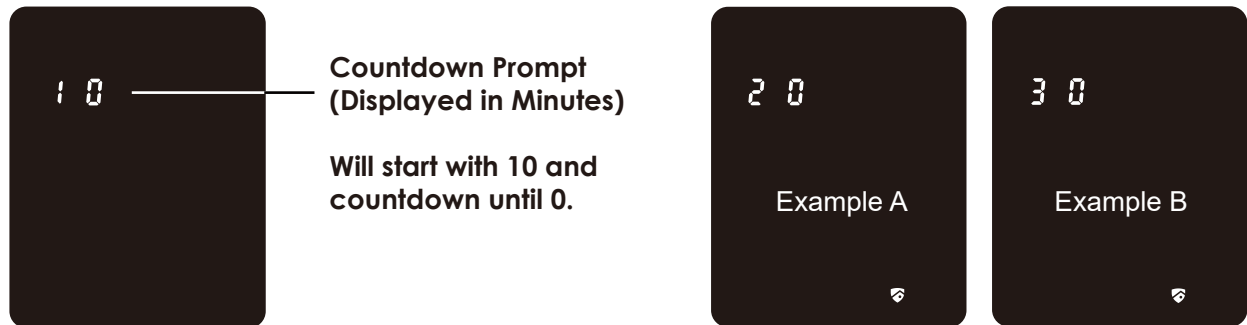



You will see a “10” on the screen, notifying the number of minutes that the keypad is disabled for. After **10 minutes**, you may attempt to enter the correct **Access Code** to unlock the door. After the second incorrect attempt to unlock the lock with the wrong **Access Code**, Lockly will disable the keypad for **20 minutes**, displaying a “20” on the screen. After the third wrong attempt to unlock the door with the correct **Access Code**, the screen will be disabled for **30 minutes**. (Example A and Example B above).

Note: In order to conserve power, the countdown prompt will only be displayed for 3 seconds. You can reactivate the screen by sliding your hand across the screen.

4.6 Disabling Safe Mode

There are four (4) ways to disable **Safe Mode**.

Option 1 - Entering Correct Access Code

Activate the keypad by pressing and holding  for 3 seconds. Enter the correct **Access Code** twice (2) when the keypad is available, pressing  after every time the **Access Code** is entered.

Option 2 - Lockly Bluetooth App

Use the app that is synced to your Lockly to disable **Safe Mode** by unlocking the door. If you have not downloaded the app to use with your smart lock, you won't be able to use this option to disable **Safe Mode**.

Option 3 - Physical Key

There is a pair of keys supplied with your new lock. You may use the keys to manually **unlock** the door and disable **Safe Mode**. To learn how to use your physical keys, see **Section 4.3**.

Option 4 - Registered Fingerprint

Use any registered fingerprint to reactivate the keypad. The door will unlock and reactivate the keypad once a registered fingerprint is used.

4.7 Rain Mode

Like other digital electronic products water can trigger to activate the touchscreen and fingerprint sensor which may cause the batteries to drain. To protect the lock and extend battery life, you can setup your Lockly to enter Rain Mode to shut off keypad and fingerprint reader whenever rain or water is detected.

Activate this feature on the Lockly app. While you are within the Bluetooth range or remotely connected thru Wi-Fi hub (Secure Link), go to **Settings > Rain Mode** and toggle the button  to turn ON.



IMPORTANT

To reactivate fingerprint and keypad access when your lock has entered rain mode, turn the key cover.

When RAIN MODE is ON, the keypad and fingerprint sensor cannot be used. Unlock via Lockly App, physical key, or voice with your Amazon Alexa or Google Assistant-enabled devices. Rain Mode auto exits every 30-mins and re-enters if water or rain is still present.

If you are using the Lockly app, you will be notified when Lockly entered rain mode and it be recorded in your access history.

If you have not yet connected your device to Lockly App, follow below steps to activate the rain mode feature:

RAIN MODE ON

1. Long press  to enter fixed digit keypad.
2. Enter **access code +234+** .
- example: 135790 + 234 +** 
3. You will hear a short beep and Bluetooth indicator flashes green once Rain Mode is ON.

RAIN MODE OFF

1. Long press  to enter fixed digit keypad.
2. Enter **access code +890+** .
- example: 135790 + 890 +** 
3. You will hear a long beep and Bluetooth indicator flashes green once Rain Mode is OFF.

4.8 Shine Mode

Lockly touchscreen keypad brightness was designed for optimum battery life. However, some users may need to adjust the brightness to their convenience to enter access codes.

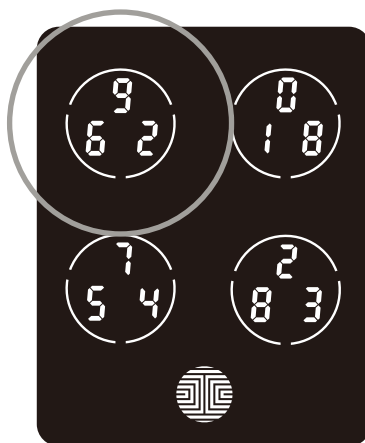

Swipe your fingers across the keypad to light up to its normal brightness.
To adjust brightness, **long press the upper left button for 3 seconds.**



The touchscreen keypad will automatically return to normal brightness after the screen dimmed.

4.9 Welcome Mode

Welcome Mode temporarily disables auto locking, keeping the door open for a specified period of time eliminating the need to enter access codes, fingerprint or using Mobile App.

Enable this feature through the Lockly App. Go to **Settings > Enable Welcome Mode**, then slide button to enable and set the specific time you require your door unlocked.

5.1 Video Doorbell

Lockly Vision™ Elite has a built-in HD video doorbell with real-time video streaming on your smartphone and real-time 2-way voice interaction. Recordings are stored locally on the TF card, with no monthly fees, and you can access video recordings from anywhere using the Lockly app. To enjoy these features, make sure the below procedures are done correctly:

- Setup the Vision Connect Hub according to Installation Manual (See Step 10)
- Download the Lockly App and connect Lockly Vision™ Elite according to on-screen instructions
- Allow your smartphone to receive push notifications or alerts from your Lockly app. Please check on iOS or Android™ procedures for allowing push notifications and alerts.
- If you're an existing Lockly app user, make sure you have the latest firmware. Go to Settings > Firmware Upgrade.



Doorbell

When someone press on the doorbell button, the smart lock will ring. The LED lights indicate the following:

- — — - Vision is initiating the call. If the red light flashes, it failed to connect to the hub or network.
- — — - Vision is connected to the App
- — — - Ready to Talk (3 blinks)

REMINDER: Install the provided “Please Ring Doorbell on Door Lock” plate on a clean and dry surface pointing the arrow to Lockly Vision™ Elite to remind guests.

5.1 Video Doorbell

When the doorbell is pressed, you will receive a notification through the Lockly app. Once you tap on the notification, app will automatically open to allow you to see who's at your door.



Tap the Call icon to initiate conversation.



Enhanced Alert Notification

Lockly Vision™ Elite has an enhanced alert notification feature. When someone rings your doorbell and you were unable to answer, you will receive a 2nd alert notification.

We suggest you keep this feature **ON** if you expect to be in areas with unreliable internet connection and you do not wish to miss any important visitors. You can **switch off** this feature in the Lockly App, otherwise.

5.1 Video Doorbell

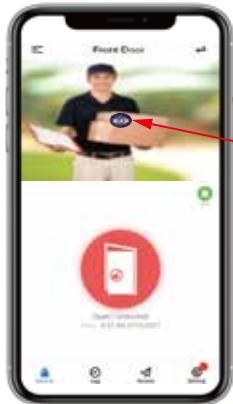

Live View

You can open the Lockly App and tap on the camera to see what Vision sees at all times.



Microphone

Tap mic to mute or unmute.

End Call

Tap icon to hang up without opening the door.

Unlock

Tap icon to unlock door.

TIP: Limit video interaction with guests to prolong battery life.

5.1 Video Doorbell

Video Recording

Lockly Vision™ Elite stores video recording on the local TF card and recording can be accessed on the log history on your Lockly app.

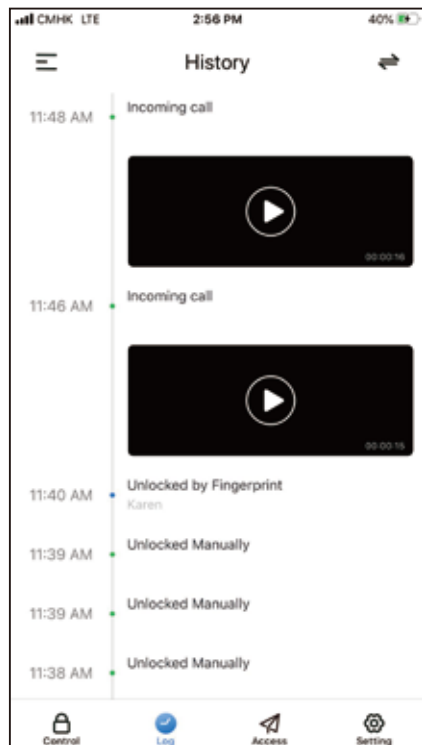

Vision automatically initiate video recording when below conditions take place:

- Keypad was used *
- Motion was detected*
- Doorbell button was pushed
- Keyhole cover was opened
- Offline Access Code™ was used*
- eKey was used*
- Wrong (PIN) access code was used and lock entered in to Safe Mode

REMINDER:

- Video recordings can be customized through the Lockly App settings*.
- Ensure the TF card is properly inserted on Vision Connect to save the recordings¹.

5.2 Night Vision

When video calls or video recordings are made, Vision Elite will automatically switch modes to either day or night vision according to the environment detected. This is the default settings of Vision Elite Night Vision feature. The settings can be changed in the Lockly app.

Auto Mode:	Vision Elite will automatically switch modes to day or night vision
Day Mode:	Night vision is always OFF
Night Mode:	Night vision is always ON



IMPORTANT:

Keeping the Night mode ON will increase power consumption and may result to a shorter battery life.

5.3 Loitering Alert

Vision Elite Motion Sensor with AI anti-false alert automatically records videos and pushes notification to smartphone when a moving object is detected. The Loitering Alert can be set ON or OFF on the Lockly app. Loitering Alert detection duration time and distance can also be adjusted on the app.



IMPORTANT:

1. Loitering Alert by default is OFF. Please turn ON and set duration and distance in the Lockly app. Reset Loitering alert whenever factory resetting is restored.
2. Loitering Alert will be suspended due to
 - Vision Elite is Unlocked
 - Battery level is below 20%
 - Welcome Mode is ON
 - Door Locking occurred in the past 60 seconds
3. Storm door or screen door will block the passive infrared motion sensor.

5.4 Offline Access Code™ (OAC)

The **Offline Access Code™ (OAC)** is a unique feature of our smart lock. It allows you to grant access to guests remotely without guests needing to download the app.

To use the **OAC** feature, make sure you download the Lockly app for iOS or Android™ first, and sync your smart lock to your mobile device. OAC can only be issued by the administrative owner of the lock.

From there, you can then issue an **Offline Access Code™** within the app.

Go to “**Access**” and choose “**Add a New User, then select Offline Access Code™ (OAC)**” and follow on screen instructions to generate your **Offline Access Code™**.

Understanding Offline Access Code™ (OAC)

OAC are issued to the guest by asking them to enter 4-12 digit number after a double-click on the . Your Lockly randomly generates the **Offline Access Code™** which can be shared to your guests together with the instructions generated using the Lockly app.

After a double-click on the , touchscreen will display numbers on **Fixed Digit** mode, then guest can enter the **Offline Access Code™**.

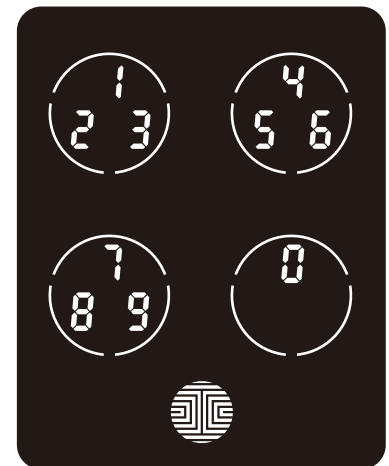

5.5 Sub-Admin Access

Sub-Admin Access can be created to grant access for others to be able to control your lock and grant access to others via Bluetooth when within range of your Lockly smart lock. The sub-admin permission can be setup through the Lockly App then write in bold.

You can select the Validity Period and User Permissions of the sub-admin.

Sub Admins will not be able to access the lock remotely but Sub Admin will be able to grant limited access codes to users when within Bluetooth range. Once Sub Admin control is setup, you as the Admin will no longer be able to issue Offline Access Code™ (OAC).

The Sub-Admin access is ideal for long term property leasing and Airbnb tenants.

6.1 Re-keying

Lockly smart lock comes with a 6-pin cylinder which can be replaced with regularly purchased DIY re-keying kit available in the market.

If you are not familiar with this process, please contact a professional locksmith. For more information, visit : <http://support.Lockly.com/faq/rekeying/>

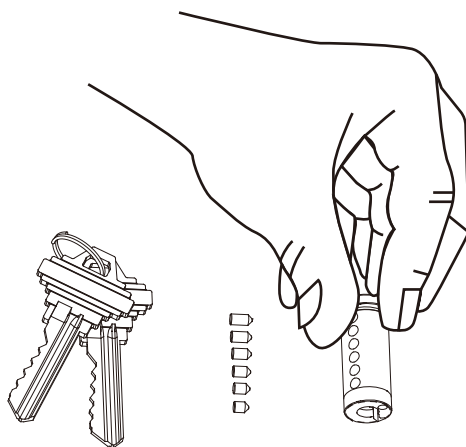

7.1 Important Notes

Auto Lock Feature

You can program the auto lock timing through the Lockly App. If auto-lock is not activated and door is still open, the touch-screen will remain lit, simply press the  on the keypad to lock.

One-Touch Locking

You can always manually lock by touching anywhere on the touchscreen. Lockly smart lock is shipped with this feature already activated. You may deactivate this feature through the Lockly App.

9V Backup Access

When your **Lockly** is out of power, you can temporarily activate the keypad by connecting a 9V battery to the bottom part of the side exterior assembly. Please see **Section 2.7** for more info.

Physical Keys / Tamper Proof Recording

Even though you have your **fingerprints** registered and **Access Codes** stored, it's always best practice to carry your physical keys with you at all times in case for any reason your lock falls into **Safe Mode**. Your video recording will be triggered whenever a key is used.

Activation Code

You may find an **Activation Code Card** with an **Activation Code** included in your package. It is very crucial that you do not lose this card. Please store this card safely as you will need the default **Activation Code** on that card to **master reset** your lock in case, for any reason, you have lost the phone paired to Lockly and also forgot your **Access Code**.

Troubleshooting

Please visit <http://Lockly.com/help> for troubleshooting and the most frequently asked questions and answers.

8.1 Cleaning

Making sure your Lockly is clean is best practice to ensure optimal product use. Follow the DOs and DON'Ts below.

DO

- Rinse the touchscreen with warm water prior to cleaning.
- Use the application of soap with a damp, lukewarm cloth.
- Airdry or wipe dry with a soft microfiber cloth to avoid scratches.

DON'T

- Don't use abrasives, high alkaline cleaners, or gasoline to clean your lock.
- Don't apply cleaning detergent directly in sunlight or at high temperatures.
- Don't leave cleaning detergent on the display keypad for long periods of time - wash immediately.
- Don't use scrapers, squeegees, or razors.

9.1 Safety Precautions

Please read all instructions carefully. Remind all Lockly users of the safety precautions.

Read the following instructions for your own safety

Do not attempt to disassemble the smart lock by yourself. It can cause product damage, void warranty, and cause injuries.

Do not use any inappropriate tools that can cause damages or malfunction to your lock.

Always make sure your door is securely closed and locked when you leave your house to prevent unwanted entry.

Please keep your Access Codes safe. Restrict access to the back panel of your smart lock and check your settings regularly to ensure Access Codes have not been changed without your knowledge.

Always dispose of used batteries according to your local laws. DO NOT BURN.



Unauthorized changes and modifications may void your product warranty. If you have questions or any problems while using your Lockly Vision™ Elite, contact our customer service department at help@Lockly.com or visit <http://Lockly.com/help> for technical assistance.

FCC Warning:

This device complies with Part 15 of the FCC Rules. Operation is subject to the following two conditions: (1) This device may not cause harmful interference, and (2) this device must accept any interference received, including interference that may cause undesired operation.

NOTE 1: This equipment has been tested and found to comply with the limits for a Class B digital device, pursuant to part 15 of the FCC Rules. These limits are designed to provide reasonable protection against harmful interference in a residential installation. This equipment generates, uses and can radiate radio frequency energy and, if not installed and used in accordance with the instructions, may cause harmful interference to radio communications. However, there is no guarantee that interference will not occur in a particular installation. If this equipment does cause harmful interference to radio or television reception, which can be determined by turning the equipment off and on, the user is encouraged to try to correct the interference by one or more of the following measures:

- Reorient or relocate the receiving antenna.
- Increase the separation between the equipment and receiver.
- Connect the equipment into an outlet on a circuit different from that to which the receiver is connected.
- Consult the dealer or an experienced radio/TV technician for help.

NOTE 2: Any changes or modifications to this unit not expressly approved by the party responsible for compliance could void the user's authority to operate the equipment.

FCC Radiation Exposure Statement

Vision Connect complies with FCC radiation exposure limits set forth for an uncontrolled environment. It should be installed and operated with minimum distance 20cm between the radiator & your body.

IC WARNING

This device contains licence-exempt transmitter(s) that comply with Innovation, Science and Economic Development Canada's licence-exempt RSS(s). Operation is subject to the following two conditions:

- (1) This device may not cause interference.
- (2) This device must accept any interference, including interference that may cause undesired operation of the device.

L'émetteur/récepteur exempt de licence contenu dans le présent appareil est conforme aux CNR d'Innovation, Sciences et Développement économique Canada applicables aux appareils radio exempts de licence. L'exploitation est autorisée aux deux conditions suivantes:

1. L'appareil ne doit pas produire de brouillage;
2. L'appareil doit accepter tout brouillage radioélectrique subi, même si le brouillage est susceptible d'en compromettre le fonctionnement.

IC Radiation Exposure Statement

This equipment meets the exemption from the routine evaluation limits in section 2.5 of RSS-102. It should be installed and operated with a minimum distance of 20cm between the radiator and any part of your body.

Cet équipement est conforme à l'exemption des limites d'évaluation habituelle de la section 2.5 de l'norme RSS-102. Il doit être installé et utilisé à une distance minimale de 20 cm entre le radiateur et toute partie de votre corps.



WARNING: This product can expose you to chemicals including Lead, which is known to the State of California to cause cancer. For more information go to www.P65Warnings.ca.gov.

LOCKLY VISION™ ELITE



We're here to help!
help@Lockly.com
<https://Lockly.com/help>

To ensure you have access to the most updated and newly added features of your Lockly smart lock, please visit: www.Lockly.com/newfeatures

For digital versions and instructional videos, please visit the following link:

<http://Lockly.com/help>

© Copyright 2022 Lockly All rights reserved

USA Patent No. US 9,881,146 B2 | USA Patent No. US 9,853,815 B2 | USA Patent No. US 9,875,350 B2 | USA Patent No. US 9,665,706 B2 | USA Patent No. US 11,010,463 B2 | AUS Patent No. 2013403169 | AUS Patent No. 2014391959 | AUS Patent No. 2016412123 | UK Patent No. EP3059689B1 | UK Patent No. EP3176722B1 | Other Patents Pending

The Bluetooth® word mark and logos are registered trademarks owned by the Bluetooth SIG, Inc., and any use of such marks by Lockly is under license. Other trademarks and trade names are those of their respective owners. Google, Android, Google Play and Google Home are trademarks of Google LLC., Amazon, Alexa and all related logos are trademarks of Amazon.com, Inc., or its affiliates.