

ERP机型: PL45D1UQ-GL-SMT00010A-V1

ERP P/N:

描述:说明书:PL45D1UQ/PGD698DW,SMT000,REV.A(UMPGD69820230220),140x190mm,
80g书纸,双面印单黑, 20页40面装订本, RoHS2.0,REACH,Prop65, POPs, PAHs

K

Die Line

Designed: 曹显贵

Date: 2023-02-20

LOCKLY GUARD™

FOR COMMERCIAL USE & PROFESSIONAL INSTALLATION

WWW.LOCKLYPRO.COM
PGD698D / PGD698L

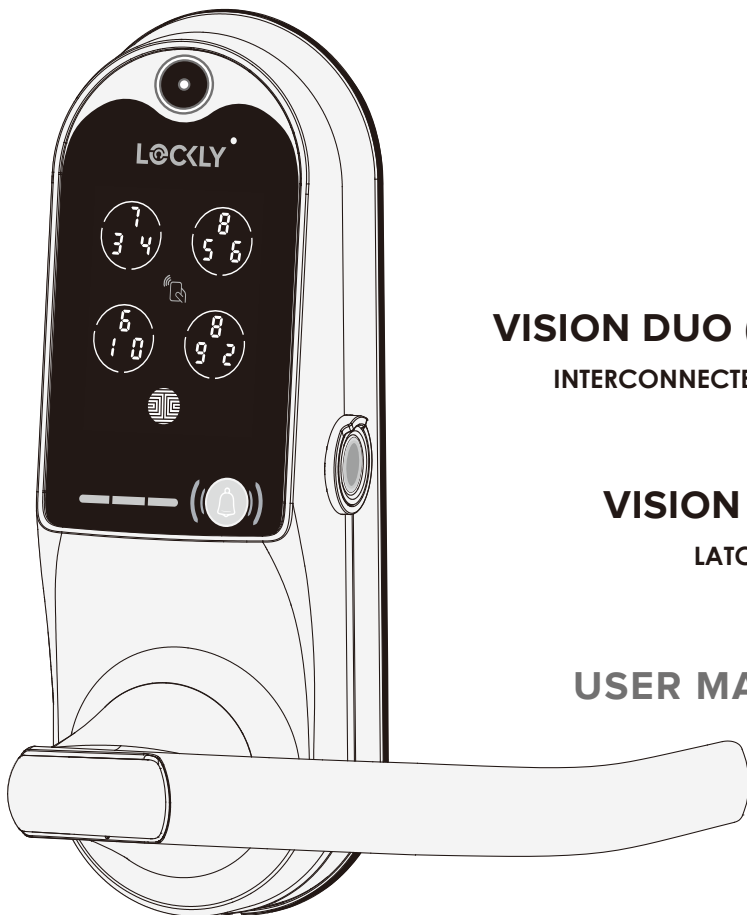

VISION DUO (698D)
INTERCONNECTED EDITION

VISION (698L)
LATCH EDITION

USER MANUAL



Intertek
Control No. XXXX

Table of Contents

Section 1 - Product Highlights

1.1 Product Features	1
----------------------	---

Section 2 - Product Overview

2.1 Product Overview - Exterior	2
2.2 Product Overview - Interior	3
2.3 Understanding Your New Lock	4
2.4 Rebooting Your Lock	5
2.5 Low Battery	6
2.6 Changing The Battery	7

Section 3 - Using Your Smart Lock

3.1 Configuring Access	8
3.2 Entering Programming Mode	9
3.3 Pairing to a New Mobile Device	10
3.4 Adding an Access Code	11
3.5 Checking/Deleting an Access Code	11
3.6 Adding a Fingerprint	12
3.7 Adding/Deleting Fingerprints	13
3.8 Fingerprint Scanning Directions	14
3.9 Fingerprint Scanning Tips & Troubleshoot	15
3.10 Adding an RFID card	15
3.11 Checking/Deleting an RFID Card	17

Section 4 - Locking and Unlocking

4.1 Unlocking with Access Codes	17
4.2 Unlocking with Fingerprints	19
4.3 Unlocking with RFID	20
4.4 Locking/Unlocking with Physical Key	20

4.5 Locking/Unlocking with App	21
4.6 Unlock with QR Code	22
4.7 Locking/Unlocking with Door Handle	22
4.8 Safe Mode - Overview	23
4.9 Rain Mode	25
4.10 Shine Mode	26
4.11 Welcome Mode	26

Section 5 - Video Doorbell

5.1 Video Doorbell	27
--------------------	----

Section 6 - Advanced Features

6.1 Offline Access Code (OAC)	31
6.2 Sub Admin Access	32

Section 7 - Re-keying

7.1 Re-keying	32
---------------	----

Section 8 - Important Notes

8.1 Important Notes	33
---------------------	----

Section 9 - Maintenance and Cleaning

9.1 Cleaning	34
9.2 Calibrating the Lock	34

Section 10 - Safety Precautions

10.1 Safety Precautions	35
-------------------------	----

For additional support, visit <http://locklypro.com/support> or email prosales@lockly.com



1.1 Product Features

Video Monitoring and Recording

See who's at your front door with Live View camera streaming, real-time high-resolution video from your smartphone. Video recordings are stored locally with no monthly fees.

Patented Hack-Proof PIN Genie Keypad

Digits are randomly displayed on the keypad ensuring access codes to be undetectable to intruders after repeated use. Numbers are randomly distributed across 4 buttons, with 3 numbers in each button. Users can press any button showing their number. Location of the numbers are always different everytime someone uses the keypad, making it hard for prying eyes to guess the correct code.

Multiple Access Codes & Monitoring

Store up to 37 Access Codes for family, friends and guests, as well as monitor entry and exit records.

Advanced 3D Fingerprint Recognition

Biometric Fingerprint Recognition protocol allows up to 99 registered fingerprints to be used and accepts only actual fingerprints - preventing lifted prints from being used.

Live Monitoring

Through your smartphone, monitor door access from anywhere in the world and securely control who comes and goes with the Vision Connect Hub. (PGH123X-Vision Connect Hub).

RFID Card Access

Supports up of 999 MIFARE RFID cards for quick and easy access.

Offline Access Code™ (OAC)

The offline access code can allow owners to issue access codes, set the allowed access duration, all without Locky Guard ever connecting to the internet, so in case of power outage, you can still magically and remotely issue Access Codes without any connection to the web.

Auto-Lock

Users no longer have to worry about forgetting to lock the door. With Auto Lock enabled, Locky Guard will automatically auto-lock the door based on your customized timing set between 5-300 seconds.

Backup Keys and 9V Battery Socket

The door can be opened with physical backup keys. There is also a 9V battery connection socket for emergency power backup to access the key pad in case your smart lock runs out of battery.

2.1 Product Overview - Exterior

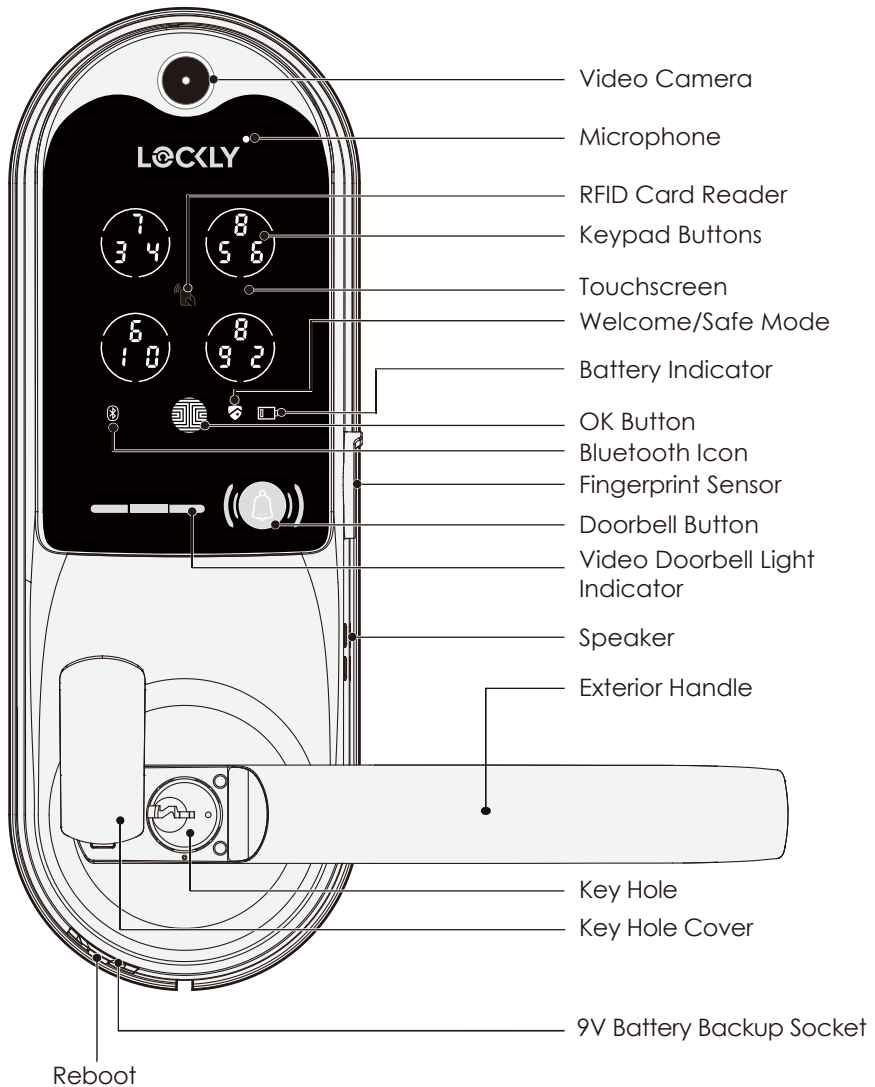

2.2 Product Overview - Interior

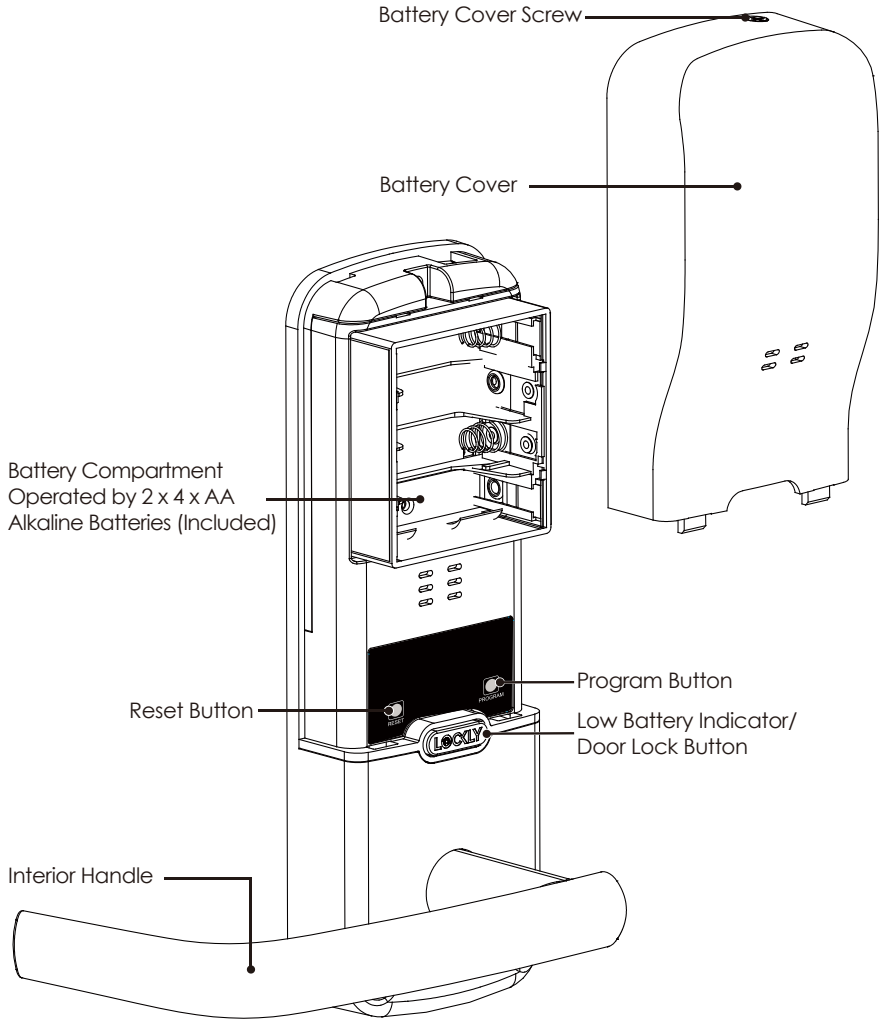

2.3 Understanding Your New Lock

After the installation of your new Lockly Guard™ Vision, understanding some key functions of operating your smart lock is important. The next sections will walk you through configuring Access Codes, adding fingerprints, RFID cards, video doorbell recording, rebooting, setting advanced features on the App, configuring Offline Access Code™ (OAC) and other features of your lock.

For any questions you can always visit <http://Locklypro.com/help> for assistance.

Don't forget that in order for Lockly Guard™ Vision, to work with full features, it is required to pair it with the LocklyPro Commercial App available for both iOS and Android™ smart devices. Please download the app by visiting the link below.

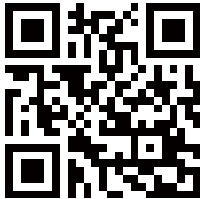

Scan or visit Locklypro.com/app



2.4 Rebooting Your Lock



NOTICE

Reboot Lockly Guard in case of dead battery or malfunction. No settings will be changed and all Access Codes will still be stored within Lockly Guard.

Press and release the reboot button when you want to reboot the lock. Your Lockly Guard will beep once after reboot. Only reboot when necessary.

To reboot, find the reboot button located on the bottom of the exterior side of Lockly Guard lock. The reboot button is located in the middle of the two 9V battery backup sockets.

You will need something small such as a paperclip, to press the reboot button. Insert the paperclip and press down firmly and let go. Your screen should restart and the lock should reboot automatically.

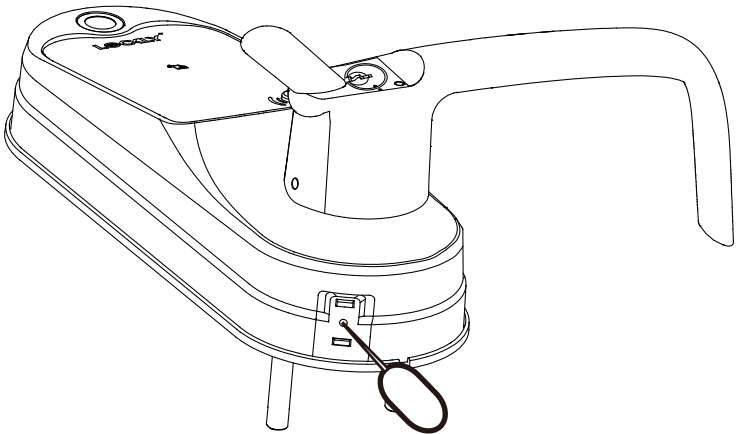

Reboot Button

2.5 Low Battery

When the battery is in seriously low condition, Lockly Guard will make continuous beeping sounds in addition to the flashing low battery icon on the touch screen. You should replace batteries **immediately** to avoid your smart lock from **shutting down**.

When your smart lock low-battery warning alert finally dies, you will have 3 chances to unlock your smart lock either by a password, APP or fingerprint. If the unlock was successful, the low-battery warning alert will be on for 1 minute. After which, the smart lock will go to dead-battery mode and will lock auto lock in 5 seconds and the screen will display a low-battery icon.

Condition	Indicator	Solution
Low Battery	Battery Icon on the display keypad will light up to indicate low battery  . At the same time, Lockly logo on the interior panel will flash red to reminder users that battery is low.	Replace batteries immediately to avoid battery failure. Lockly Guard can still operate up to 300 cycles in low battery condition.
Dead Battery	When there is no display and sounds; and screen is non -functional.	Replace batteries immediately. Supplied physical backup keys can be used to unlock the door. Alternatively, use a 9V battery as shown below to temporarily activate the lock.

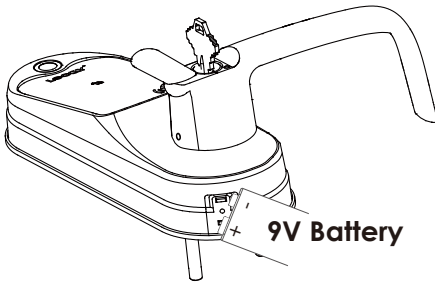

Your Lockly Guard will automatically detect battery polarity. So hold your 9V battery lead in place against bottom of the Lockly Guard to **temporarily** activate the screen to enter your **Access Code**. Be sure to hold the 9V battery against the contact points located at the bottom of the lock until you have successfully unlocked your door with your **Access Code**. Once unlocked, batteries should be replaced immediately.

2.6 Changing The Battery

Under normal use, the Lockly Guard battery will last up to a year. Please check battery levels **regularly** and change your batteries when the low battery notification is issued. For best practice, always use **new batteries** by a major brand.

Open the battery compartment cover and insert **eight (8)** new **AA alkaline** batteries as shown. Be sure to unscrew the screw located on the top of the cover first by unscrewing counter clockwise before sliding the cover up.

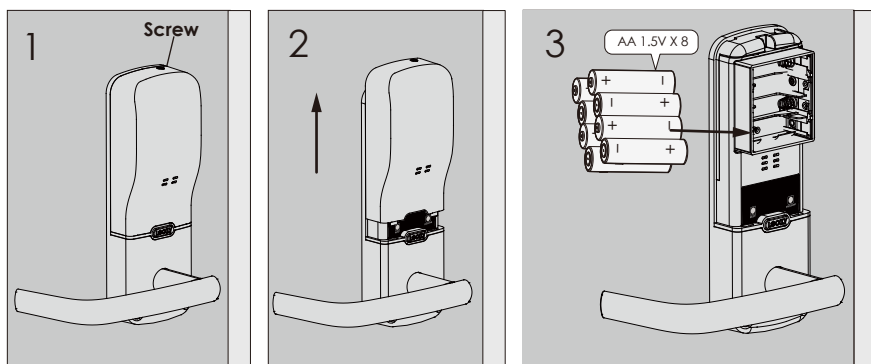

- Make sure the batteries are oriented correctly by matching the orientation displayed.
- Replacing the batteries do not reset stored **Access Codes**.



NOTICE

Whenever batteries are replaced, reconnecting the smart lock to your smartphone App is required.

If you have not yet downloaded the app, visit:
Locklypro.com/app

3.1 Configuring Access



Pair your lock to your smart phone to manage your access codes. Follow the on screen instructions to complete the setup.

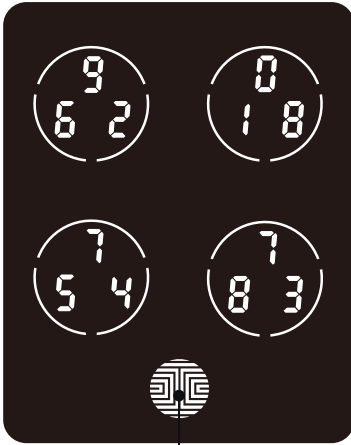

How to Use the Keypad

There are a total of **five (5) buttons** on the keypad as shown in the example image to the left. The numbers in each button may differ than what is shown on your device than what is displayed here.

To enter your required digit, just simply press the circle where your number is shown. You do not need to press the actual number as anywhere within the circle will suffice.

The button on the bottom is the **OK** button. You will be pressing this button when you are done entering your **Access Code**.

OK Button



NOTICE The Default Access Code is **1 2 3 4 5 6**

Your new Lockly Guard **Access Code** can be any combination of **6 to 8 digits**. Once a new Access Code is entered, the **Default Access Code** of **123456** would be deleted. A maximum of 37 sets of Access Codes can be stored for use at any given time. To add more than 37 Access Codes, you must delete an existing Access Code before adding a new code.

There are different types of Access Codes that can be generated using the LocklyPro Commercial App. Each type of access code have different levels of permission you can select for your guests, tenants, deliveries, helpers, etc., Get the latest updates on access codes, send an email to prosales@lockly.com or visit: support.lockly.com/faq/accesscode

3.2 Entering Programming Mode

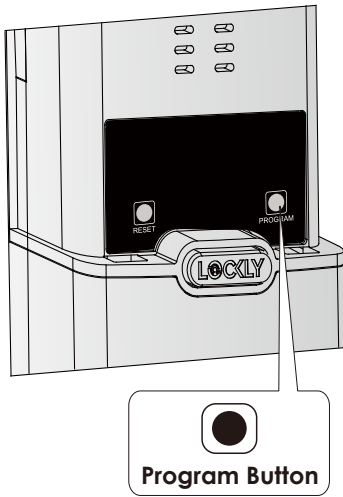

To enter **Programming Mode**, remove the battery compartment cover on the interior side of the Lockly Guard to expose the **Program** buttons.

Simply press the **Program** button to enter programming mode.

Note: Program button will be disabled once synced to a smart phone. Configure all settings via synced smart phone.

To end **Programming Mode**, press the **Program** button anytime. **Programming Mode** will automatically exit if the keypad is inactive for more than thirty (30) seconds.

You will need to scan the ACTIVATION CODE* that comes with the lock to pair your lock with the app. See Step 10-14 of the Installation Guide to pair Vision on the new LocklyPro Commercial app account.

*The activation code card is attached to the welcome card inside the package. Store it for future use. Once you have registered your lock on the LocklyPro app, you have the option to save it on the PIN Genie Vault. To access details for future use, check your account information and go to PIN Genie Vault.

3.3 Pairing to a New Mobile Device

PAIR WITH HUB

In the programming mode, select **"PA"** to pair the gateway. If you're not in programming mode, see **Section 3.2** to enter programming.

After pressing **"PA"**, the PA icon will flash, and you will hear a tone prompt indicating that you are in pairing mode. You need to press the Vision Connect Hub reset button three times within 20 seconds.

If the pairing is successful, you will hear a long "beep". If the pairing fails, you will hear three "beeps". You need to re-enter the programming mode, and then enter the hub pairing mode **"PA"** to pair again the device.

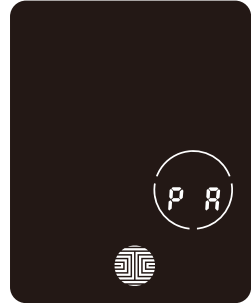

PAIR TO APP

To pair your smart lock to a new mobile phone, download the LocklyPro Commercial app on your new mobile phone then use the same account to login to your LocklyPro Commercial App on the new mobile device. If you're pairing your Lockly Guard to a new LocklyPro Commercial app account, follow the steps below

1. On the old LocklyPro Commercial app account, go to Settings > Reset and pairing > Perform Factory Reset.
2. Download, register and log in to the new LocklyPro Commercial app account.
3. You will need to scan the **ACTIVATION CODE*** that comes with the lock to setup to a new account.



Old LocklyPro Commercial app account



Scan to new LocklyPro Commercial app account

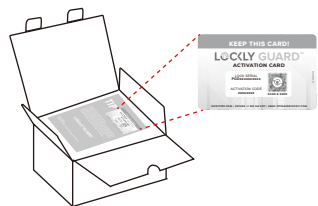

IMPORTANT

DO NOT INSERT ANY PINS TO RESET HOLES OF LOCKLY GUARD VISION / VISION DUO OR VISION CONNECT without consulting our support team. If you cannot remove your Lockly Guard from the old account, please contact LocklyPro support (855) 562-5599 or email: prosales@lockly.com

3.4 Adding an Access Code

Enter the App Access Management settings then tap **"Add New User"**. Select the the type of user you wish to add access, **"Trusted User"**, **"Guests"**, **"One-Time Access"**. For example, select **Trusted User**, **enter the user's name** and **set the Access Code**. Re-enter the access code, then tap **"Confirm"** to successfully add the new access code.

An access code is a combination of 6 to 8 digits. The Administrator can set up to 37 sets of access codes and these can only be added through the App.

Default access code (123456) becomes invalid once an administrator access code is setup.

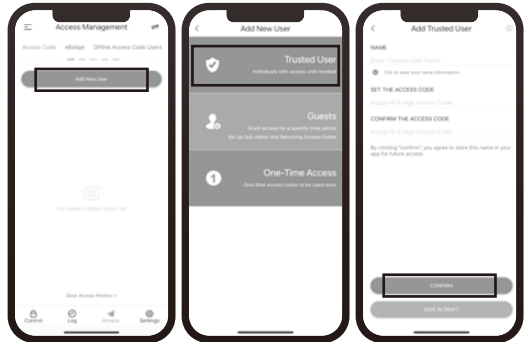

3.5 Checking/Deleting an Access Code

Access codes can only be deleted through the App. Enter the App Access Management and you can view all the issued access code users. Tap the access code user you wish to be deleted. Check access code and user name is correct, then tap **"Delete User"** to complete deleting the user access code.



The default access code 123456 can not be deleted until a new access code has been setup. Immediately setup a new access code and delete the default access code for your security.

3.6 Adding a Fingerprint

We are using an advanced biometric sensor, providing the most secure fingerprint authentication. For security reasons, Lockly Guard will only accept fingerprint patterns that consist of cross intersection points. Patterns with no cross intersection points will not be acceptable.

Please check your fingers before registration to make sure the finger you want to register will be acceptable by our system. Otherwise, use an alternative finger to ensure successful registration.

The following examples show which types of fingerprint patterns will be acceptable. It is highly recommended to enroll at least one finger from each hand in case the hand you are using is unavailable, such as, in instances like if you are holding items in that hand or have sustained an injury.

Fingerprint Pattern
with Cross
Intersection Lines



Concentric or Parallel
Pattern with no Cross
Intersection Lines



Fingerprint with
Scars or Worn Out
Ridges



Your Lockly Guard can register up to **ninety-nine (99) fingerprints**. Please read the following sections if you want to add or delete fingerprints. We recommend using your app to add fingerprints, however, the following section can show you without using the app.

3.7 Adding/Deleting Fingerprints

Fingerprints can only be added or deleted through the App. On the App Access Management, select Fingerprint, then tap **"Add New Fingerprint"**.

Scan your finger by lightly placing your designated finger on the sensor until you hear a beep. Lift your finger and repeat the process until the digit "6" shown on the screen becomes "1". If you have successfully scanned and registered your fingerprint, you will hear a beep and PASS will be displayed on the keypad. Press  to exit. If you did not successfully register your fingerprint, FAIL will show on the keypad. If FAIL is displayed, return to the previous App menu and rescan your finger.



For fingerprint scanning directions, please refer to **Section 3.8**.

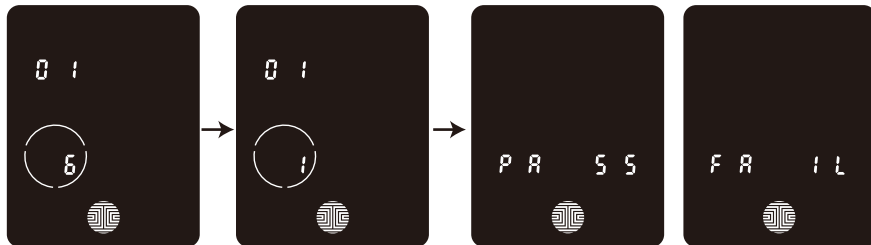

IMPORTANT

Please make sure your fingers are clean from dirt and oils before scanning your fingerprint. Make sure the sensor is also clean by taking a soft cloth and wiping the surface.

To **delete fingerprint access**, on the App Access Management, select Fingerprint. All registered fingerprint profiles will be shown. Scroll down, select the tap the profile you wish to delete. Check and then tap **"Delete User"** to confirm and complete deleting the fingerprint.

3.8 Fingerprint Scanning Directions

The **fingerprint sensor** equipped in your smart lock is loaded with powerful fingerprint algorithms to extract quality features from fingers, even in poor conditions. Placing your finger on the sensor correctly helps consistency in fingerprint recognition. The following directions and tips will guide you on how to scan an optimal fingerprint image.

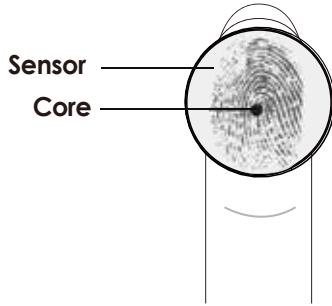
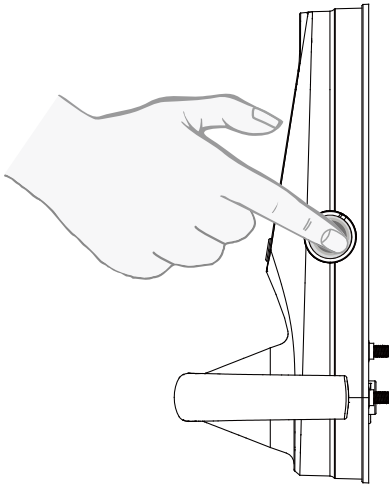

Position your finger on the **center** of the sensor

Top View

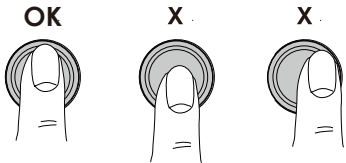

Correct



Side View



Incorrect

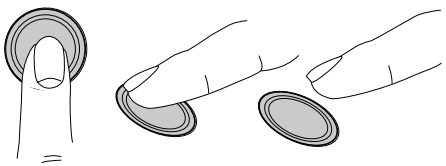

3.9 Fingerprint Scanning Tips & Troubleshoot

Tips for Fingerprint Enrollment and Recognition

- Place your finger to completely cover the sensor with maximum contact surface.
- Position the center of your finger (core) to the center of the sensor.
- Hold your finger still for more than a second until you hear a beep.
- Scan a finger that is clean and free from dirt.
- Children ages 12 and under are not recommended to use fingerprint access due to the constant changes of their fingers during growth.
- Elderly with fading fingerprints may have difficulty in recognition.
- If your finger has a cut, scar, or cracked skin due to dryness, try another finger.
- If your fingerprint reader is having issues recognizing your fingerprint to unlock due to varying physical and weather conditions such as moist, sweaty, cold or dry; please add an extra scanning of the finger in such condition. This will improve the fingerprint reader's speed and recognition.

Troubleshooting Fingerprints

In case of poor fingerprint conditions

- If wet - wipe excess moisture from finger before scanning
- If dirty - wipe stains and dirt off from finger before scanning
- Make sure the sensor is clean from dirt or smudges - wipe sensor with soft cloth regularly

For more troubleshooting help, visit [http:// LocklyPro.com/support](http://LocklyPro.com/support)

3.10 Adding an RFID card

RFID cards can only be added through the APP, and a maximum of **999** RFID cards can be added.

On the App Access Management, select RFID card then tap **"Add New RFID Card"**



3.10 Adding an RFID card (Continued)

The Lockly Guard keypad will lit up and show the number sequence of the RFIDs to be added.

Place the card into RFID card reading area.

- After the RFID card is successfully added, the keyboard will display PASS, and then give a long "beep". The display will automatically exit and illuminate with the PIN Genie screen.
- If the RFID card is not successfully added, the keyboard will display FAIL, and then the screen will close with "beep" twice. If FAIL is displayed, return to the previous application menu and try Add New RFID Card.

NOTE: When adding an RFID card, make sure the screen lit up and the card is close to the RFID reading area, within 1 cm.

If an RFID card is damaged or the card has not been encrypted properly, it cannot be added and used normally.

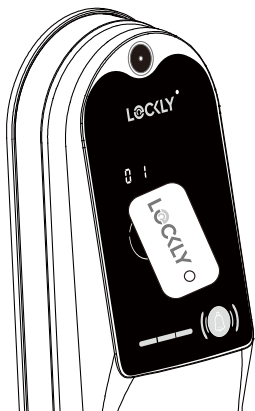

Place the **RFID card** to the screen where the **RFID card** sensor is embedded.

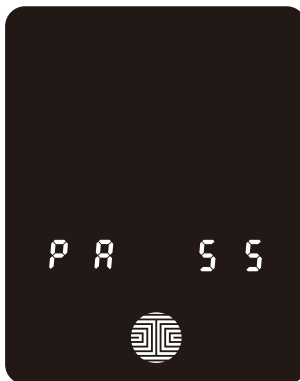

PASS will show on the keypad once card is registered successfully.

3.11 Checking/Deleting an RFID Card

The RFID card can only be deleted/checked through the APP.

On the App Access Management, select RFID Card. All registered RFID cards will be shown. Scroll down, select the tap the profile you wish to delete. Check and then tap **"Delete User"** to confirm and complete deleting the RFID card.



4.1 Unlocking with Access Codes

Lockly Guard Smart Lock can be unlocked using multiple ways - via your stored Access Code, registered fingerprint, smartphone with Bluetooth, the physical key supplied with your lock, or RFID card.

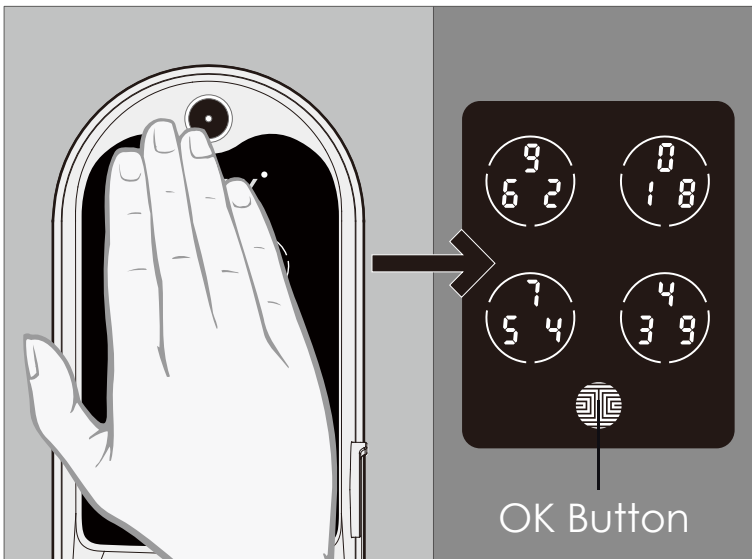

4.1 Unlocking with Access Codes (Continued)

Slide your hand across the screen to activate the keypad.

Enter your **6 to 8 digit Access Code** followed by the **OK** button. Press **OK** anytime to reset if you entered the wrong digit.

If the **Access Code** entered is correct, the door will unlock. If the **Access Code** entered is incorrect, Lockly Guard will beep twice.



Ten consecutive wrong attempts will put Lockly Guard in "Safe Mode". (See Section 4.8)

Lock your Lockly Guard by pressing the **OK Button** or by brushing your hand across the screen anytime when the door is closed. The smart lock will also auto-lock after unlocking based on your set auto-lock settings.

You may toggle between two types of keypad displays to enter your **Access Code**. The **fixed** digit version and the PIN Genie version (Recommended). Press and hold the **OK Button** for 3 seconds to toggle back and forth between the two keypads.

(Sample display shown only)

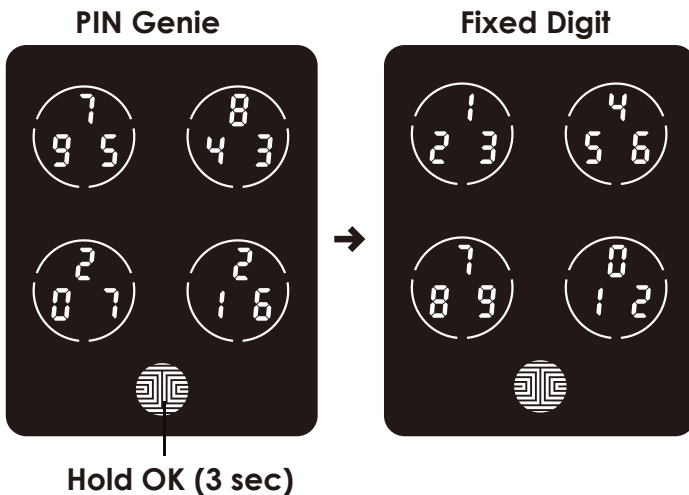

4.2 Unlocking with Fingerprints

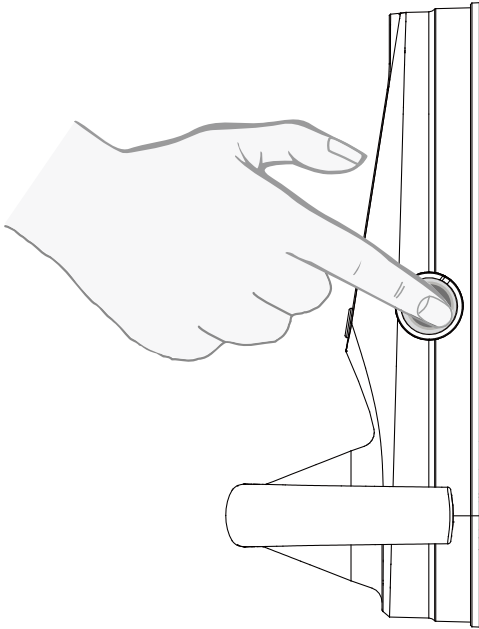

Unlocking

Place a registered finger to the **fingerprint scanner** located on the **exterior side** of the lock to the right.

To register a **fingerprint**, please see **Section 3.7**.

If your fingerprint is **registered** and acknowledged, you will hear a “beep” sound and a **Green LED** will light up on the **fingerprint scanner**. You can then push down the handle and open the door.

If you see a **Red LED**, it means your fingerprint is not recognized. Try again or use another registered fingerprint.

For best fingerprint scanning practices, see **Section 3.8**.

Locking

To lock your smart lock, swipe your hand across touchscreen. The lock should close (lock). If the touchscreen is ON, touch  , the lock should lock as well.

4.3 Unlocking with RFID



Place your **RFID card** closer to the panel.

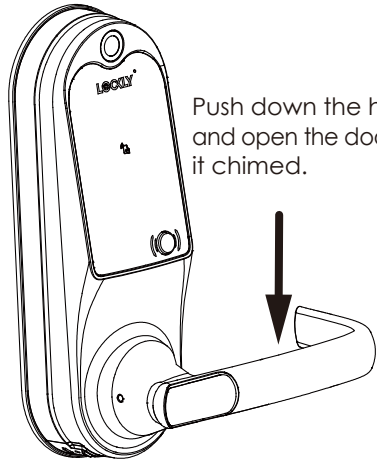

Push down the handle and open the door after it chimed.

4.4 Locking/Unlocking with Physical Key

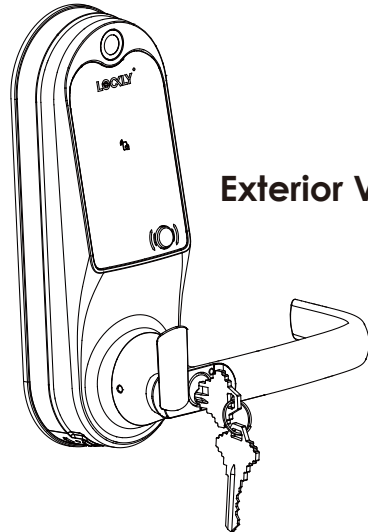
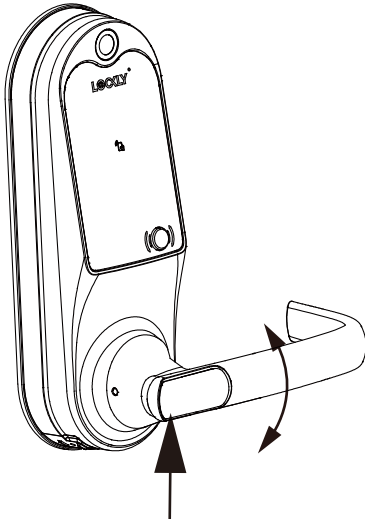

Exterior View

To **unlock** your lock using the **physical key (included)**, open the key cover on the handle by turning the cover to reveal the **keyhole**.

Insert your key and turn **clockwise** or **counter clockwise** to lock or unlock the door.

4.5 Locking/Unlocking with App

You must have the LocklyPro iOS or Android app installed in order to lock and unlock with smartphone. Please download the app by visiting the link below or search "LocklyPro" from the correct app store.

Scan or visit
locklypro.com/app

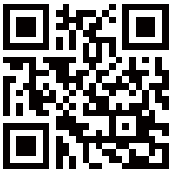

4.6 Unlock with QR Code

If you have multiple Locky Guard door locks, you can use the LocklyPro Commercial app code scanner to unlock.

A QR code sticker (blue color) comes together with your lock. Open the LocklyPro Commercial app and scan it to unlock. You may also generate a unique QR code via LocklyPro Commercial app for your smart lock.

You can generate QR code, print according to the size you want and stick it next to your door.

4.7 Locking/Unlocking with Door Handle

This smart lock is built with an anti-friction latch and deadbolt throw (698D only) for added security. The latch throw can be setup to auto lock based on your customized timing through the LocklyPro Commercial app.

To **UNLOCK** push the handle downwards and push door to open. This action is necessary to open your door whenever you access by keypad, fingerprint RFID card or smartphone App.

On both 698L or 698D, the latch throw will auto lock according to your customized time or simply lift the handle to lock the latch throw. On 698D, the deadbolt throw will lock when the handle is lifted upwards.

Follow instructions on LocklyPro Commercial APP on handle configuration to ensure the lock correctly detects whether the door is lock or unlock.

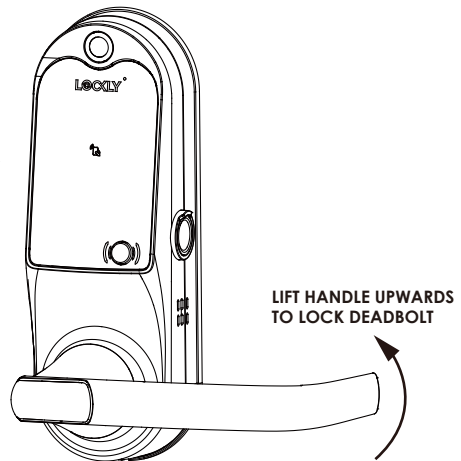

4.8 Safe Mode - Overview

Lockly Guard will enter **Safe Mode** when ten (10) consecutive wrong **Access Codes** are entered within 5 minutes. When in **Safe Mode**, the lock status icon  will start to flash.

To disable **Safe Mode**, you must unlock the door using a registered fingerprint, access via mobile App, unlock using the keyhole, pressing the Lockly Guard logo button on the interior panel or by pushing down the interior handle or enter the correct **Access Code** twice in a row. Activate the keypad by pressing and holding  for 3 seconds.

Once the screen is activated, enter the correct **Access Code** carefully twice, pressing  after every time.

If you enter the wrong code, the keypad will then be disabled for **10 minutes**.

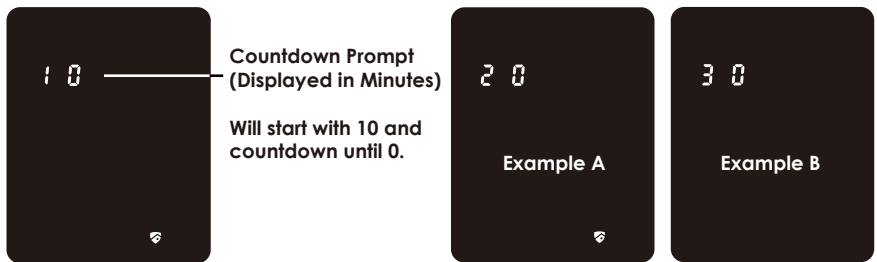



You will see a “10” on the screen, notifying the number of minutes that the keypad is disabled for. After **10 minutes**, you may attempt to enter the correct **Access Code** to unlock the door. After the second incorrect attempt to unlock the lock with the wrong **Access Code**, Lockly Guard will disable the keypad for **20 minutes**, displaying a “20” on the screen. After the third wrong attempt to unlock the door with the correct **Access Code**, the screen will be disabled for **30 minutes**. (Example A and Example B above).

Note: In order to conserve power, the countdown prompt will only be displayed for 3 seconds. You can reactivate the screen by sliding your hand across the screen.

4.8 Disabling Safe Mode

There are five (5) ways to disable Safe Mode.

Option 1 - Entering Correct Access Code

Activate the keypad by pressing and holding  for 3 seconds. Enter the correct **Access Code** twice (2) when the keypad is available, pressing  after every time the **Access Code** is entered.

Option 2 - LocklyPro Bluetooth App

Use the app that is synced to your Lockly Guard to disable **Safe Mode** by unlocking the door. If you have not downloaded the app to use with your smart lock, you won't be able to use this option to disable **Safe Mode**.

Option 3 - Physical Key

There is a pair of keys included with your new lock. You may use the keys to manually **unlock** the door. To learn how to use your physical keys, see **Section 4.4**.

Option 4 - Registered Fingerprint

Use any registered fingerprint to reactivate the keypad. The door will unlock and reactivate the keypad once a registered fingerprint is used.

Option 5 - Registered RFID card

Use any registered RFID card to reactivate the keypad. The door will unlock and reactivate the keypad once a registered RFID card is used.

4.9 Rain Mode

Like other digital electronic products water can trigger to activate the touchscreen and sensor which may cause the batteries to drain. To protect the lock and extend battery life, you can setup your Lockly Guard to enter Rain Mode to shut off keypad and fingerprint reader whenever rain or water is detected.

Activate this feature on the LocklyPro Commercial app. While you are within the Bluetooth range or remotely connected thru Wi-Fi hub (Secure Link), go to **Settings > Rain Mode** and toggle the button  to turn ON.

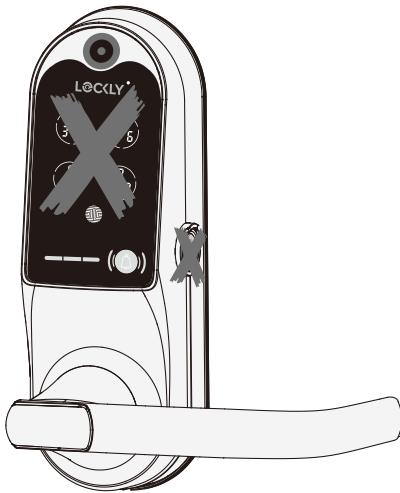

IMPORTANT

When RAIN MODE is ON, the keypad, RFID card and fingerprint sensor cannot be used. Unlock via LocklyPro Commercial App or, physical key. Rain Mode auto exits every 30-mins and re-enters if water or rain is still present.

If you are using the LocklyPro Commercial app, you will be notified when Lockly Guard entered rain mode and it will be recorded in your access history.

If you have not yet connected your device to LocklyPro Commercial App, follow below steps to activate the rain mode feature:

RAIN MODE ON

1. Long press  to enter fixed digit keypad.
2. Enter **access code +234+**  .
example: 135790 + 234 + 
3. You will hear a short beep and Bluetooth indicator flashes green once Rain Mode is ON.

RAIN MODE OFF

1. Long press  to enter fixed digit keypad.
2. Enter **access code +890+**  .
example: 135790 + 890 + 
3. You will hear a long beep and Bluetooth indicator flashes green once Rain Mode is OFF.

4.10 Shine Mode

Lockly Guard touchscreen keypad brightness was designed for optimum battery life. However, some users may need to adjust the brightness to their convenience to enter access codes.

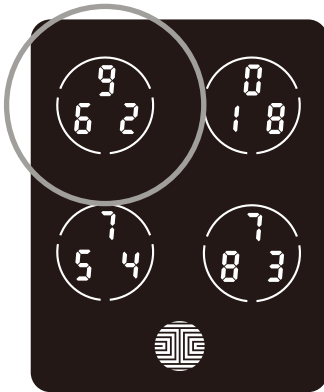

Swipe your fingers across the keypad to light up to its normal brightness. To adjust brightness, **long press the upper left button for 3 seconds**.



The touchscreen keypad will automatically return to normal brightness after the screen dimmed.

4.11 Welcome Mode

Welcome Mode temporarily disables auto locking, keeping the door open for a specified period of time eliminating the need to enter access codes, fingerprint or using Mobile App.

Enable this feature through the LocklyPro Commercial App. Go to > **Settings** > **Enable Welcome Mode**, then slide button to enable and set the specific time you require your door unlocked.

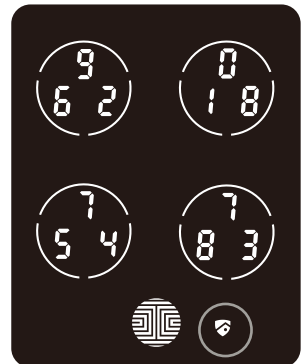

NOTICE

To ensure Welcome Mode works normally after replacing the battery, reconnect the lock to the Lockly app to synchronize the time.

5.1 Video Doorbell

Lockly Guard™ Vision has a built-in HD video doorbell with real-time video streaming on your smartphone and real-time 2-way voice interaction. Recordings are stored locally on the TF card, with no monthly fees, and you can access video recordings from anywhere using the Lockly app. To enjoy these features, make sure the below procedures are done correctly:

- Setup the Vision Connect Hub according to Installation Manual (See Step 11)
- Download the Lockly App and connect Lockly Guard™ Vision according to on-screen instructions
- Allow your smartphone to receive push notifications or alerts from your Lockly app. Please check on iOS or Android™ procedures for allowing push notifications and alerts.
- If you're an existing LocklyPro Commercial app user, make sure you have the latest firmware. Go to Settings > Firmware Upgrade.

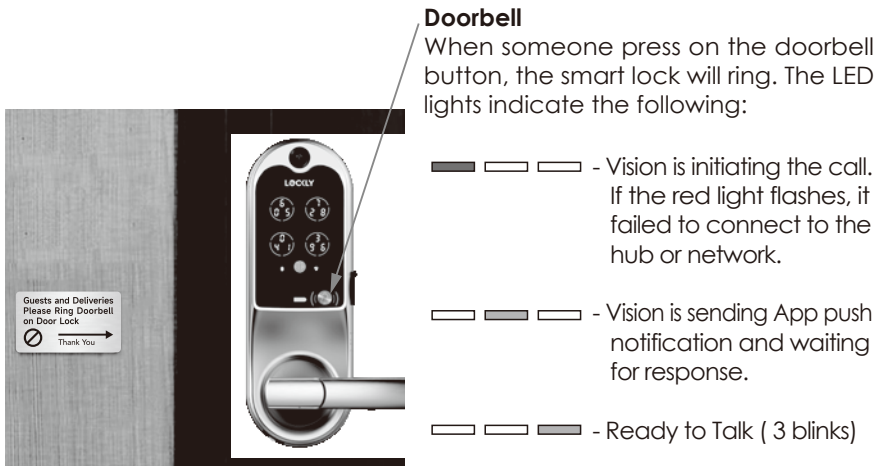

REMINDER: Install the provided "Please Ring Doorbell on Door Lock" plate on a clean and dry surface pointing the arrow to Lockly Guard™ Vision to remind guests.

5.1 Video Doorbell (Continued)

When the doorbell is pressed, you will receive a notification through the LocklyPro Commercial app. Once you tap on the notification, app will automatically open to allow you to see who's at your door.



Tap the Call icon to initiate conversation.



Enhanced Alert Notification

Lockly Guard™ Vision has an enhanced alert notification feature. When someone rings your doorbell and you were unable to answer, you will receive a 2nd alert notification.

We suggest you keep this feature **ON** if you expect to be in areas with unreliable internet connection and you do not wish to miss any important visitors. You can **switch off** this feature in the Lockly App, otherwise.

5.1 Video Doorbell (Continued)

Vision enables you to attend to your door when you are not at home. While using the app, you can use the icons below to view, initiate conversations and unlock door.



Live View

You can open the LocklyPro Commercial App and tap on the camera to see what Vision sees at all times.



Microphone

Tap mic to mute or unmute.

End Call

Tap icon to hang up without opening the door.

Unlock

Tap icon to unlock door.

TIP: Limit video interaction with guests to prolong battery life.

5.1 Video Doorbell (Continued)

Video Recording

Lockly Guard™ Vision stores video recording on the local TF card and recording can be accessed on the log history on your LocklyPro Commercial app.

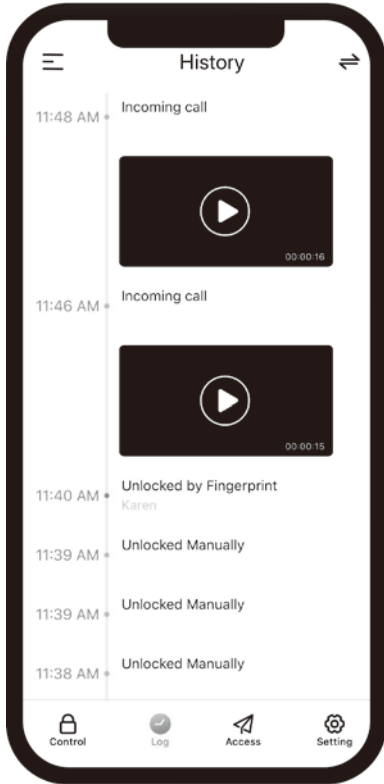

Vision automatically initiate video recording when below conditions take place:

- Keypad was used to unlock
- Doorbell was pushed
- Offline Access Code™ was used*
- eKey was used*
- Wrong (PIN) access code was used and lock entered in to Safe Mode

REMINDER:

- Video recordings can be customized through the LocklyPro Commercial App settings*.
- Ensure the TF card is properly inserted on Vision Connect to save the recordings¹.

¹Lockly Guard™ Vision TF card with regular use can store up to 1-year worth of video recordings.

6.1 Offline Access Code™ (OAC)

The **Offline Access Code™ (OAC)** is a unique feature of our smart lock. It allows you to grant access to guests remotely without guests needing to download the app.

To use the **OAC** feature, make sure you download the LocklyPro Commercial app for iOS or Android first, and sync your smart lock to your mobile device. OAC can only be issued by the administrative owner of the lock.

From there, you can then issue an **Offline Access Code™** within the app.

Go to “**Access**” and choose “**Add a New User**,” then select **Offline Access Code™ (OAC)**” and follow on screen instructions to generate your **Offline Access Code™**.

Understanding Offline Access Code™ (OAC)

OAC are issued to the guest by asking them to enter 4-12 digit number after a double - click on the  . Your Lockly Guard randomly generates the **Offline Access Code™** which can be shared to your guests together with the instructions generated using the LocklyPro Commercial app.

After a double-click on the  , touchscreen will display numbers on **Fixed Digit** mode, then guest can enter the **Offline Access Code™**.

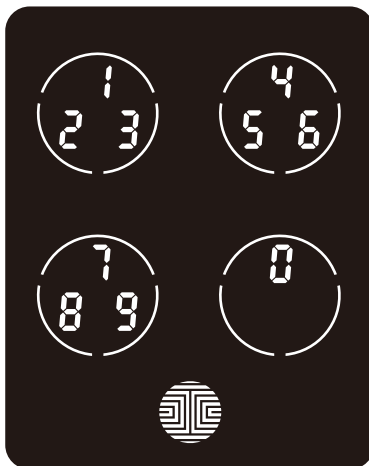

6.2 Sub Admin Access

Sub-Admin Access can be created to grant access for others to be able to control your lock and grant access to others via Bluetooth when within range of your Lockly Guard smart lock. The sub-admin permission can be setup through the LocklyPro Commercial App then **Add A New User**.

You can select the Validity Period and User Permissions of the sub-admin.

Sub Admins will not be able to access the lock remotely but Sub Admin will be able to grant limited access codes to users when within Bluetooth range. Once Sub Admin control is setup, you as the Admin will no longer be able to issue Offline Access Code™ (OAC)

The Sub-Admin access is ideal for long term property leasing and Airbnb tenants.

7.1 Re-keying

Lockly Guard smart lock comes with a 5-pin cylinder which can be replaced with regularly purchased DIY re-keying kit available in the market.

If you are not familiar with this process, please contact a professional locksmith. For more information, visit: <http://support.Lockly.com/faq/rekeying/>

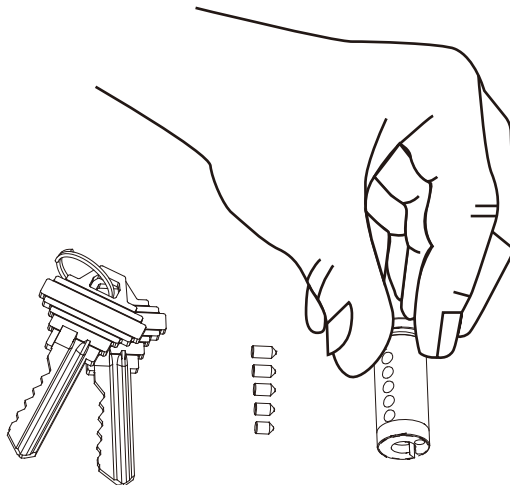

8.1 Important Notes

Auto Lock Feature

Your lock can be programmed to auto-lock between 5-300 seconds after the door opening. You can select the timing through the LocklyPro Commercial App. If auto-lock is not activated and door is still open, the touchscreen will remain lighted, simply press the  on the keypad to lock.

One-Touch Locking

You can always manually do a quick lock by touching anywhere on the touchscreen. Lockly Guard smart lock is shipped with this feature already activated. You may deactivate this feature through the LocklyPro Commercial App.

9V Backup Access

When your **Lockly Guard** is out of power, you can temporarily activate the keypad by using a 9V battery against the bottom of the exterior side of the smart lock. Please see **Section 2.5** for more info.

Physical Keys / Tamper Proof Recording

Even though you have your **fingerprints** registered and **Access Codes** stored, it's always best practice to carry your physical keys with you at all times in case for any reason your lock falls into **Safe Mode**. Your video recording will be triggered whenever a key is used.

Activation Code

You may find an **Activation Code Card** with an **Activation Code** included in your package. It is very crucial that you do not lose this card. Please store this card safely as you will need the default **Activation Code** on that card to **master reset** your lock in case, for any reason, you have lost the phone paired to Lockly Guard and also forgot your **Access Code**.

Troubleshooting

Please visit <http://Locklypro.com/support> for troubleshooting and the most frequently asked questions and answers.

9.1 Cleaning

Making sure your Lockly Guard is clean is best practice to ensure optimal product use. Follow the DOs and DON'Ts below.

DO	DON'T
<ul style="list-style-type: none">• Rinse the touchscreen with warm water prior to cleaning.• Use the application of soap with a damp, lukewarm cloth.• Air dry or wipe dry with a soft microfiber cloth to avoid scratches.	<ul style="list-style-type: none">• Don't use abrasives, high alkaline cleaners, or gasoline to clean your lock.• Don't apply cleaning detergent directly in sunlight or at high temperatures.• Don't leave cleaning detergent on the display keypad for long periods of time - wash immediately.• Don't use scrapers, squeegees, or razors.

9.2 Calibrating the Lock

If the lock was not used for a long period of time, the lubrication of the inside mechanism may affect its unlocking responses. Dust and freezing temperatures may also cause your lock to delay or not to respond to unlocking. Calibrate your lock to maintain its responsiveness.

Calibration may take 60 seconds to finish. You will hear the lock unlocking for multiple times. The unlocking sound will stop once the calibration is finished.

To calibrate the lock, enter **access code + 1234** + .

example: 135790+1234+ 

NOTE: You may also calibrate the lock using the LocklyPro Commercial App. Open the app, select the lock and go to > **Settings** > **Calibrate**.

10.1 Safety Precautions

Please read all instructions carefully. Remind all Lockly Guard users of the safety precautions.

Read the following instructions for your own safety

Do not attempt to disassemble the smart lock by yourself. It can cause product damage, void warranty, and cause injuries.

Do not use any inappropriate tools that can cause damages or malfunction to your lock.

Always make sure your door is securely closed and locked when you leave your house to prevent unwanted entry.

Please keep your Access Codes safe. Restrict access to the back panel of your smart lock and check your settings regularly to ensure Access Codes have not been changed without your knowledge.

Always dispose of used batteries according to your local laws. DO NOT BURN.



Unauthorized changes and modifications may void your product warranty. If you have questions or any problems while using your Lockly Guard Smart Lock, contact our customer service department at prosales@lockly.com or visit <http://Locklypro.com/support> for technical assistance.

FCC Warning :

This device complies with Part 15 of the FCC Rules. Operation is subject to the following two conditions: (1) This device may not cause harmful interference, and (2) this device must accept any interference received, including interference that may cause undesired operation.

NOTE 1: This equipment has been tested and found to comply with the limits for a Class B digital device, pursuant to part 15 of the FCC Rules. These limits are designed to provide reasonable protection against harmful interference in a residential installation. This equipment generates, uses and can radiate radio frequency energy and, if not installed and used in accordance with the instructions, may cause harmful interference to radio communications. However, there is no guarantee that interference will not occur in a particular installation. If this equipment does cause harmful interference to radio or television reception, which can be determined by turning the equipment off and on, the user is encouraged to try to correct the interference by one or more of the following measures:

- Reorient or relocate the receiving antenna.
- Increase the separation between the equipment and receiver.
- Connect the equipment into an outlet on a circuit different from that to which the receiver is connected.
- Consult the dealer or an experienced radio/TV technician for help.

NOTE 2: Any changes or modifications to this unit not expressly approved by the party responsible for compliance could void the user's authority to operate the equipment.

FCC Radiation Exposure Statement

This equipment complies with FCC radiation exposure limits set forth for an uncontrolled environment. It should be installed and operated with minimum distance 20cm between the radiator & your body.

IC WARNING

This equipment contains licence-exempt transmitter(s) that comply with Innovation, Science and Economic Development Canada's licence-exempt RSS(s).

Operation is subject to the following two conditions:

- (1) This device may not cause interference.
- (2) This device must accept any interference, including interference that may cause undesired operation of the device.

L'émetteur/récepteur exempt de licence contenu dans le présent appareil est conforme aux CNR d'Innovation, Sciences et Développement économique Canada applicables aux appareils radio exempts de licence. L'exploitation est autorisée aux deux conditions suivantes:

1. L'appareil ne doit pas produire de brouillage;
2. L'appareil doit accepter tout brouillage radioélectrique subi, même si le brouillage est susceptible d'en compromettre le fonctionnement.

IC Radiation Exposure Statement

This equipment meets the exemption from the routine evaluation limits in section 2.5 of RSS-102. It should be installed and operated with a minimum distance of 20cm between the radiator and any part of your body.

Cet équipement est conforme à l'exemption des limites d'évaluation habituelle de la section 2.5 de la norme RSS-102. Il doit être installé et utilisé à une distance minimale de 20 cm entre le radiateur et toute partie de votre corps.



WARNING: This product can expose you to chemicals including Lead, which is known to the State of California to cause cancer. For more information go to www.P65Warnings.ca.gov.

To ensure you have access to the most updated and newly added features of your Lockly Guard smart lock, please visit:

www.locklypro.com/698L

www.locklypro.com/698D



VISION DUO (698D) | INTERCONNECTED EDITION

VISION (698L) | LATCH EDITION



We're here to help!
prosales@lockly.com
locklypro.com/support

© Copyright 2022 Lockly All rights reserved

US Patent NO. US 9,881,146 B2 | US Patent NO. US 9,853,815 B2 | US Patent NO. US 9,875,350 B2 | US Patent NO. US 9,665,706 B2 | US Patent NO. US 11,010,463 B2 | AU Patent NO. 2013403169 | AU Patent NO. 2014391959 | AU Patent NO. 2016412123 | UK Patent NO. EP3059689B1 | UK Patent NO. EP3176722B1 | Other Patents Pending

The Bluetooth® word mark and logos are registered trademarks owned by the Bluetooth SIG, Inc. , and any use of such marks by Lockly is under license. Other trademarks and trade names are those of their respective owners. Google, Android and Google Play are trademarks of Google LLC.