

TEST REPORT

Reference No..... : WTX22X12255074W001
FCC ID : 2ASIVPGA387
Applicant : PIN GENIE, INC. DBA LOCKLY
Address..... : 676 Transfer Rd., St. Paul, MN 55114
Manufacturer : Smart Electronic Industrial (Dong Guan) Co., Ltd.
Address..... : Qing Long Road, Long Jian Tian Village, Huang Jiang Town, Dong Guan,
Guang Dong, China
Product Name : Wireless Exit Button
Model No..... : PGA387
Standards : FCC Part 15.231
Date of Receipt sample : 2022-12-19
Date of Test..... : 2022-12-19 to 2023-01-03
Date of Issue : 2023-01-03
Test Report Form No. : WTX_Part 15_231W
Test Result..... : **Pass**

Remarks:

The results shown in this test report refer only to the sample(s) tested, this test report cannot be reproduced, except in full, without prior written permission of the company. The report would be invalid without specific stamp of test institute and the signatures of approver.

Prepared By:

Waltek Testing Group (Shenzhen) Co., Ltd.

Address: 1/F., Room 101, Building 1, Hongwei Industrial Park, Liuxian 2nd Road,
Block 70 Bao'an District, Shenzhen, Guangdong, China

Tel.: +86-755-33663308 Fax.: +86-755-33663309 Email: sem@waltek.com.cn

Tested by:

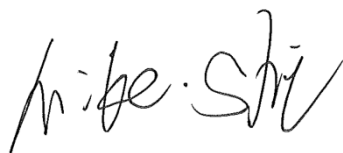

Mike Shi

Approved by:



Silin Chen

TABLE OF CONTENTS

1. GENERAL INFORMATION4
1.1 PRODUCT DESCRIPTION FOR EQUIPMENT UNDER TEST (EUT)4
1.2 TEST STANDARDS.....5
1.3 TEST METHODOLOGY5
1.4 TEST FACILITY5
1.5 EUT SETUP AND TEST MODE6
1.6 MEASUREMENT UNCERTAINTY.....7
1.7 TEST EQUIPMENT LIST AND DETAILS8

2. SUMMARY OF TEST RESULTS.....11

3. ANTENNA REQUIREMENT12
3.1 STANDARD APPLICABLE12
3.2 TEST RESULT.....12

4. RADIATED EMISSIONS13
4.1 STANDARD APPLICABLE13
4.2 TEST PROCEDURE14
4.3 CORRECTED AMPLITUDE & MARGIN CALCULATION.....15
4.4 SUMMARY OF TEST RESULTS/PLOTS.....15

5. DUTY CYCLE20
5.1 STANDARD APPLICABLE20
5.2 TEST PROCEDURE20
5.3 SUMMARY OF TEST RESULTS/PLOTS.....20

APPENDIX PHOTOGRAPHS.....22

Report version

Version No.	Date of issue	Description
Rev.00	2023-01-03	Original
/	/	/

1. GENERAL INFORMATION

1.1 Product Description for Equipment Under Test (EUT)

General Description of EUT	
Product Name:	Wireless Exit Button
Trade Name:	LOCKLY
Model No.:	PGA387
Adding Model(s):	/
Rated Voltage:	DC3V*2
Power Adaptor :	/
<i>Note: The test data is gathered from a production sample provided by the manufacturer.</i>	

Technical Characteristics of EUT	
Frequency Range:	433.97-443.97MHz
Max. Field Strength:	433.97MHz: 85.04dBuV/m(3m)
Data Rate:	/
Quantity of Channels:	41
Channel Separation:	250kHz
Modulation:	FSK
Antenna Type:	PCB Antenna
Antenna Gain:	0dBi
<i>Note: The Antenna Gain is provided by the customer and can affect the validity of results.</i>	

1.2 Test Standards

The tests were performed according to following standards:

FCC Rules Part 15.231: Periodic operation in the band 40.66-40.70MHz and above 70MHz.

ANSI C63.10-2013: American National Standard for Testing Unlicensed Wireless Devices.

Maintenance of compliance is the responsibility of the manufacturer. Any modification of the product, which result in lowering the emission/immunity, should be checked to ensure compliance has been maintained.

1.3 Test Methodology

All measurements contained in this report were conducted with ANSI C63.10-2013, the equipment under test (EUT) was configured to measure its highest possible emission level. The test modes were adapted accordingly in reference to the Operating Instructions.

1.4 Test Facility

Address of the test laboratory

Laboratory: Waltek Testing Group (Shenzhen) Co., Ltd.

Address: 1/F., Room 101, Building 1, Hongwei Industrial Park, Liuxian 2nd Road, Block 70 Bao'an District, Shenzhen, Guangdong, China

FCC – Registration No.: 125990

Waltek Testing Group (Shenzhen) Co., Ltd. EMC Laboratory has been registered and fully described in a report filed with the FCC (Federal Communications Commission). The acceptance letter from the FCC is maintained in our files. The Designation Number is CN5010, and Test Firm Registration Number is 125990.

Industry Canada (IC) Registration No.: 11464A

The 3m Semi-anechoic chamber of Waltek Testing Group (Shenzhen) Co., Ltd. has been registered by Certification and Engineering Bureau of Industry Canada for radio equipment testing with Registration No.: 11464A and the CAB identifier is CN0057.

1.5 EUT Setup and Test Mode

The EUT was operated at continuous transmitting mode that was for the purpose of the measurements. All testing shall be performed under maximum output power condition, and to measure its highest possible emissions level, more detailed description as follows:

Test Mode List		
Test Mode	Description	Remark
TM1	Transmitting	433.97MHz
TM2	Transmitting	443.97MHz

Test Conditions	
Temperature:	22~25 °C
Relative Humidity:	50~55 %.
ATM Pressure:	1019 mbar

EUT Cable List and Details			
Cable Description	Length (m)	Shielded/Unshielded	With / Without Ferrite
/	/	/	/

Special Cable List and Details			
Cable Description	Length (m)	Shielded/Unshielded	With / Without Ferrite
/	/	/	/

Auxiliary Equipment List and Details			
Description	Manufacturer	Model	Serial Number
/	/	/	/

1.6 Measurement Uncertainty

Measurement uncertainty		
Parameter	Conditions	Uncertainty
Occupied Bandwidth	Conducted	$\pm 1.5\%$
Conducted Spurious Emission	Conducted	$\pm 2.17\text{dB}$
Transmission Time	Conducted	$\pm 5\%$
Conducted Emissions	Conducted	9-150kHz $\pm 3.74\text{dB}$
		0.15-30MHz $\pm 3.34\text{dB}$
Transmitter Spurious Emissions	Radiated	30-200MHz $\pm 4.52\text{dB}$
		0.2-1GHz $\pm 5.56\text{dB}$
		1-6GHz $\pm 3.84\text{dB}$
		6-18GHz $\pm 3.92\text{dB}$

1.7 Test Equipment List and Details

No.	Description	Manufacturer	Model	Serial No.	Cal Date	Due. Date
SEMT-1075	Communication Tester	Rohde & Schwarz	CMW500	148650	2022-03-22	2023-03-21
SEMT-1063	GSM Tester	Rohde & Schwarz	CMU200	114403	2022-03-22	2023-03-21
SEMT-1072	Spectrum Analyzer	Agilent	E4407B	MY41440400	2022-03-25	2023-03-24
SEMT-1079	Spectrum Analyzer	Agilent	N9020A	US47140102	2022-03-22	2023-03-21
SMET-1313	Spectrum Analyzer	Agilent	N9020A	MY54320548	2022-03-22	2023-03-21
SEMT-1080	Signal Generator	Agilent	83752A	3610A01453	2022-03-22	2023-03-21
SEMT-1081	Vector Signal Generator	Agilent	N5182A	MY47070202	2022-03-22	2023-03-21
SEMT-1028	Power Divider	Weinschel	1506A	PM204	2022-03-22	2023-03-21
SEMT-1082	Power Divider	RF-Lambda	RFLT4W5M18G	14110400027	2022-03-22	2023-03-21
SEMT-C001	Cable	Zheng DI	LL142-07-07-10M(A)	/	/	/
SEMT-C002	Cable	Zheng DI	ZT40-2.92J-2.92J-6M	/	/	/
SEMT-C003	Cable	Zheng DI	ZT40-2.92J-2.92J-2.5M	/	/	/
SEMT-C004	Cable	Zheng DI	2M0RFC	/	/	/
SEMT-C005	Cable	Zheng DI	1M0RFC	/	/	/
SEMT-C006	Cable	Zheng DI	1M0RFC	/	/	/
<input checked="" type="checkbox"/> Chamber A: Below 1GHz						
SEMT-1031	Spectrum Analyzer	Rohde & Schwarz	FSP30	836079/035	2022-03-22	2023-03-21
SEMT-1007	EMI Test Receiver	Rohde & Schwarz	ESVB	825471/005	2022-03-22	2023-03-21
SEMT-1008	Amplifier	HP	8447F	2805A03475	2022-01-07	2023-01-06
					2022-12-30	2023-12-29
SEMT-1069	Loop Antenna	Schwarz beck	FMZB 1516	9773	2021-03-20	2023-03-19
SEMT-1068	Broadband Antenna	Schwarz beck	VULB9163	9163-333	2021-03-20	2023-03-19
<input checked="" type="checkbox"/> Chamber A: Above 1GHz						
SEMT-1031	Spectrum Analyzer	Rohde & Schwarz	FSP30	836079/035	2022-03-22	2023-03-21
SEMT-1007	EMI Test	Rohde &	ESVB	825471/00	2022-03-22	2023-03-21

	Receiver	Schwarz		5		
SEMT-1043	Amplifier	C&D	PAP-1G18	2002	2022-03-22	2023-03-21
SEMT-1042	Horn Antenna	ETS	3117	00086197	2021-03-19	2023-03-18
SEMT-1121	Horn Antenna	Schwarzbeck	BBHA 9170	BBHA917 0582	2021-04-27	2023-04-26
SEMT-1216	Pre-amplifier	Schwarzbeck	BBV 9721	9721-031	2022-03-25	2023-03-24
SEMT-1163	Spectrum Analyzer	Rohde & Schwarz	FSP40	100612	2022-03-22	2023-03-21
<input type="checkbox"/> Chamber B:Below 1GHz						
SEMT-1068	Trilog Broadband Antenna	Schwarz beck	VULB9163(B)	9163-635	2021-04-09	2023-04-08
SEMT-1067	Amplifier	Agilent	8447D	2944A101 79	2022-03-22	2023-03-21
SEMT-1066	EMI Test Receiver	Rohde & Schwarz	ESPI	101391	2022-03-22	2023-03-21
<input type="checkbox"/> Chamber C:Below 1GHz						
SEMT-1319	EMI Test Receiver	Rohde & Schwarz	ESIB 26	100401	2022-01-07 2022-12-30	2023-01-06 2023-12-29
SEMT-1343	Trilog Broadband Antenna	Schwarz beck	VULB 9168	1194	2021-05-28	2023-05-27
SEMT-1333	Amplifier	HP	8447F	2944A038 69	2022-03-22	2023-03-21
<input checked="" type="checkbox"/> Conducted Room 1#						
SEMT-1001	EMI Test Receiver	Rohde & Schwarz	ESPI	101611	2022-03-21	2023-03-20
SEMT-1002	Pulse Limiter	Rohde & Schwarz	ESH3-Z2	100911	2022-03-25	2023-03-24
SEMT-1003	AC LISN	Schwarz beck	NSLK8126	8126-224	2022-03-22	2023-03-21
<input type="checkbox"/> Conducted Room 2#						
SEMT-1334	EMI Test Receiver	Rohde & Schwarz	ESPI	101259	2022-03-22	2023-03-21
SEMT-1336	LISN	Rohde & Schwarz	ENV 216	100097	2022-03-22	2023-03-21

Software List			
Description	Manufacturer	Model	Version
EMI Test Software (Radiated Emission)*	Farad	EZ-EMC	RA-03A1
EMI Test Software (Conducted Emission)*	Farad	EZ-EMC	RA-03A1

*Remark: indicates software version used in the compliance certification testing.

2. SUMMARY OF TEST RESULTS

FCC Rules	Description of Test Item	Result
§15.203	Antenna Requirement	Compliant
§15.205	Restricted Band of Operation	N/A
§15.209	Radiated Spurious Emissions	N/A
§15.231(a)	Deactivation Testing	N/A
§15.231(b)	Radiated Emissions	Compliant
§15.231(c)	20dB Bandwidth Testing	N/A
§15.207(a)	Conducted Emission	N/A
§15.231 (b)(2)	Duty Cycle	Compliant

N/A: not applicable.

C2PC: Note: Report is for C2PC only. The test data includes Radiated Emissions and Duty Cycle. Those not tested mark with N/A (not effected by the C2PC).

3. Antenna Requirement

3.1 Standard Applicable

According to FCC Part 15.203, an intentional radiator shall be designed to ensure that no antenna other than that furnished by the responsible party shall be used with the device. The use of a permanently attached antenna or of an antenna that uses a unique coupling to the intentional radiator shall be considered sufficient to comply with the provisions of this section.

3.2 Test Result

This product has a PCB Antenna, fulfill the requirement of this section.

4. Radiated Emissions

4.1 Standard Applicable

According to §15.231(b), the field strength of emissions from intentional radiators operated under this section shall not exceed the following:

Fundamental Frequency (MHz)	Field Strength of Fundamental (microvolts/meter)	Field Strength of Spurious Emissions (microvolts/meter)
40.66 - 40.70	2,250	225
70 - 130	1,250	125
130 - 174	1,250 to 3,750 **	125 to 375 **
174 - 260	3,750	375
260 - 470	3,750 to 12,500 **	375 to 1,250 **
Above 470	12,500	1,250

** linear interpolations

The limits on the field strength of the spurious emissions in the above table are based on the fundamental frequency of the intentional radiator. Spurious emissions shall be attenuated to the average (or, alternatively, CISPR quasi-peak) limits shown in this table or to the general limits shown in §15.209, whichever limit permits a higher field strength.

The emission limit in this paragraph is based on measurement instrumentation employing an average detector. The provisions in §15.35 for limiting peak emissions apply. Spurious Radiated Emissions measurements starting below or at the lowest crystal frequency.

Compliance with the provisions of §15.205 shall be demonstrated using the measurement instrumentation specified in that section.

4.2 Test Procedure

The setup of EUT is according with per ANSI C63.10-2013 measurement procedure. The specification used was with the FCC Part 15.205 15.231(b) and FCC Part 15.209 Limit.

The test setup for emission measurement below 30MHz.

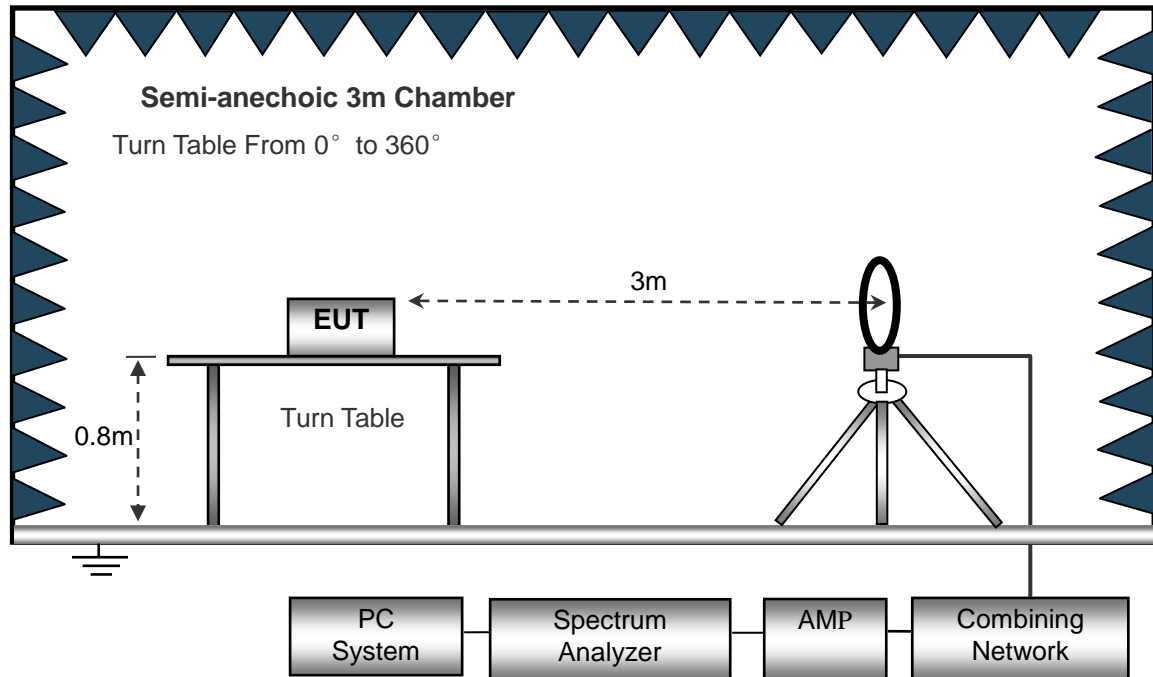

The test setup for emission measurement from 30MHz to 1GHz.

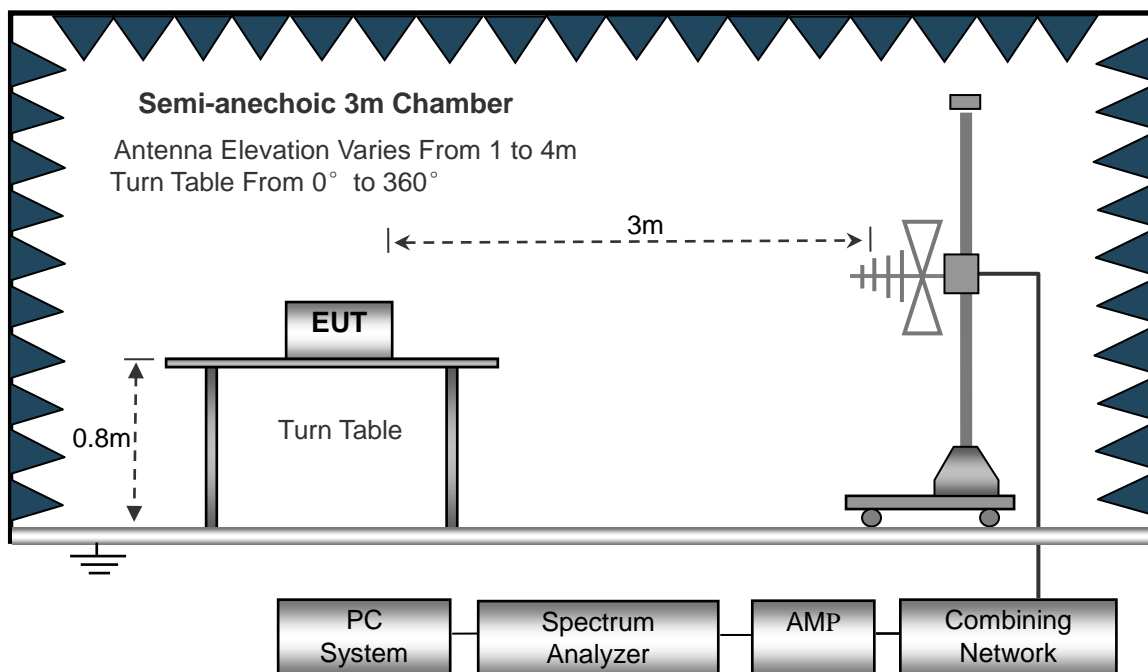

The test setup for emission measurement above 1GHz.

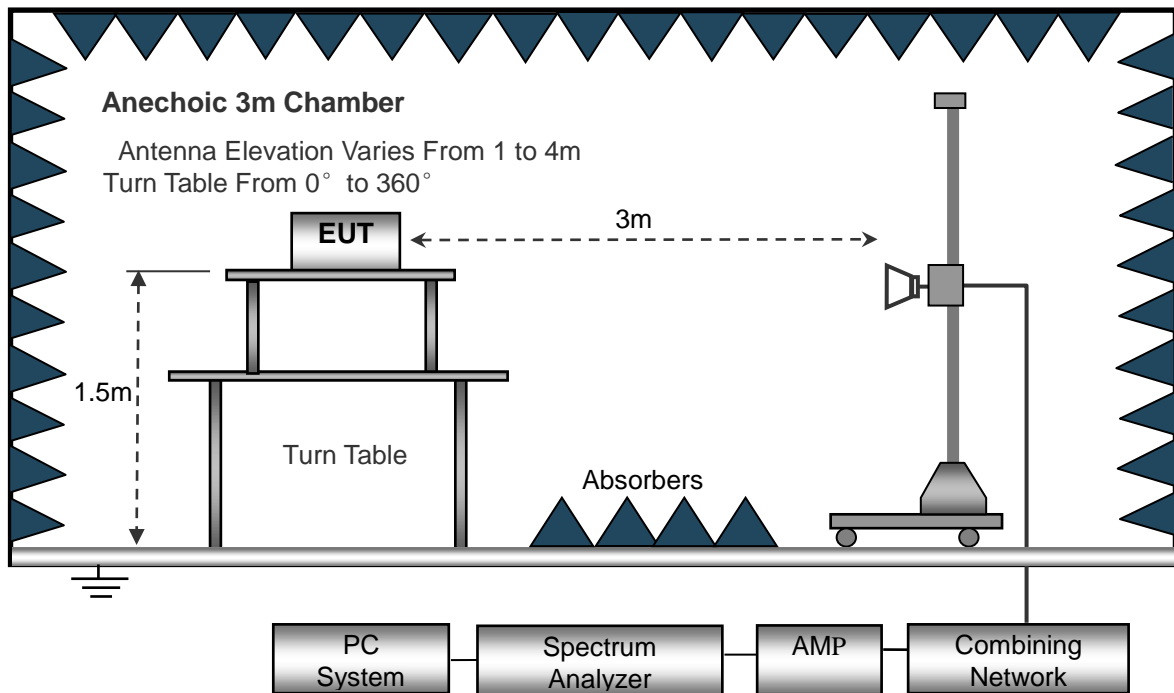

4.3 Corrected Amplitude & Margin Calculation

The Corrected Amplitude is calculated by adding the Antenna Factor and the Cable Factor, and subtracting the Amplifier Gain from the Amplitude reading. The basic equation is as follows:

$$\text{Corr. Ampl.} = \text{Indicated Reading} + \text{Ant. Loss} + \text{Cab. Loss} - \text{Ampl. Gain}$$

The “**Margin**” column of the following data tables indicates the degree of compliance with the applicable limit. For example, a margin of -6dB μ V means the emission is 6dB μ V below the maximum limit. The equation for margin calculation is as follows:

$$\text{Margin} = \text{Corr. Ampl.} - \text{FCC Part 15C Limit}$$

4.4 Summary of Test Results/Plots

Note: this EUT was tested in 3 orthogonal positions and the worst case position data was reported.

Test Mode	TM1	Polarity:	Horizontal
-----------	-----	-----------	------------

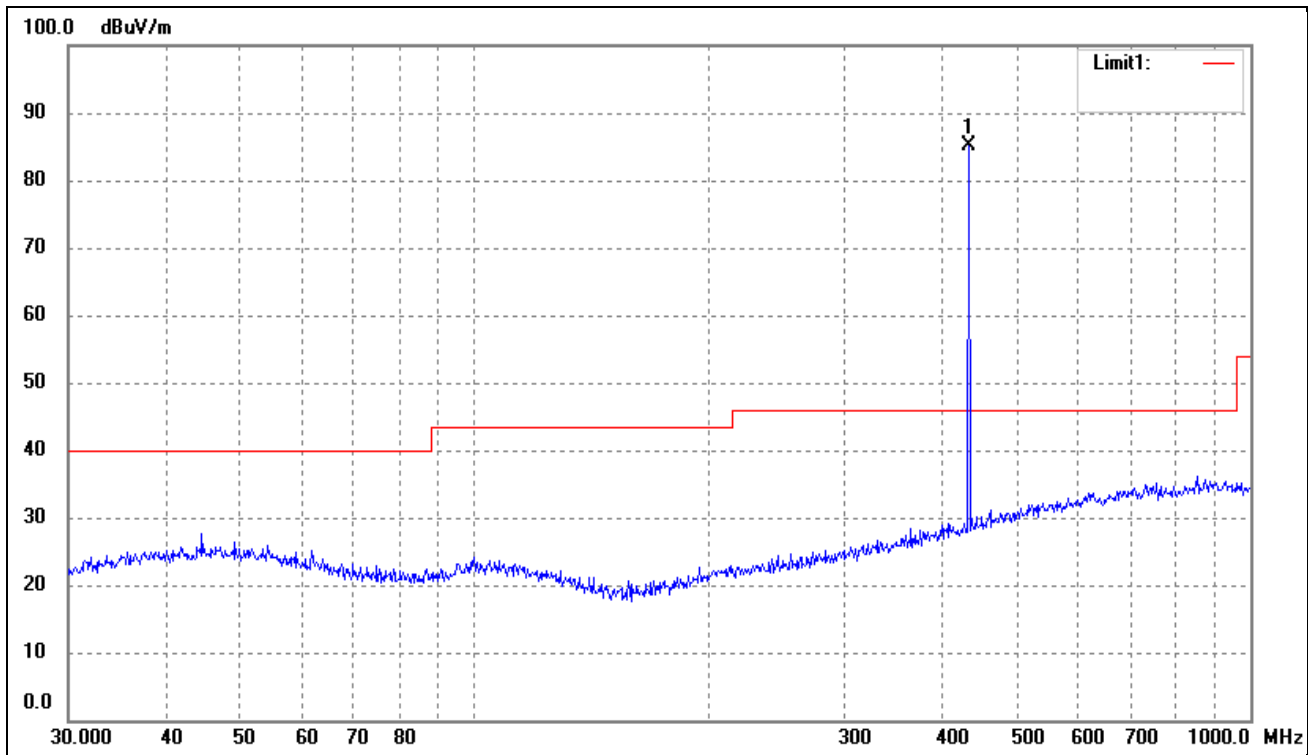

No.	Frequency	Reading	Corr.	Duty cycle	Result	Limit	Margin	Deg.	Height	Remark
	MHz	dBuV/m	Factor (dB)	Factor (dB)	dBuV/m	dBuV/m	(dB)	(°)	(cm)	
1	433.9851	87.78	-2.74	N/A	85.04	100.83	-15.79	-	-	peak
/	/	/	/	-9.76	75.28	80.83	-5.55	-	-	Ave

Above 1GHz

No.	Frequency	Reading	Corr.	Duty cycle	Result	Limit	Margin	Deg.	Height	Remark
	MHz	dBuV/m	Factor (dB)	Factor (dB)	dBuV/m	dBuV/m	dB	(°)	(cm)	
1	1909.469	53.39	-10.21	43.18	74.00	-30.82	-20.16	-	-	Peak
2	3351.599	52.95	-6.20	46.75	74.00	-27.25	-10.49	-	-	Peak
3	4660.494	50.59	-3.14	47.45	74.00	-26.55	-23.93	-	-	Peak

Test Mode	TM1	Polarity:	Vertical
-----------	-----	-----------	----------

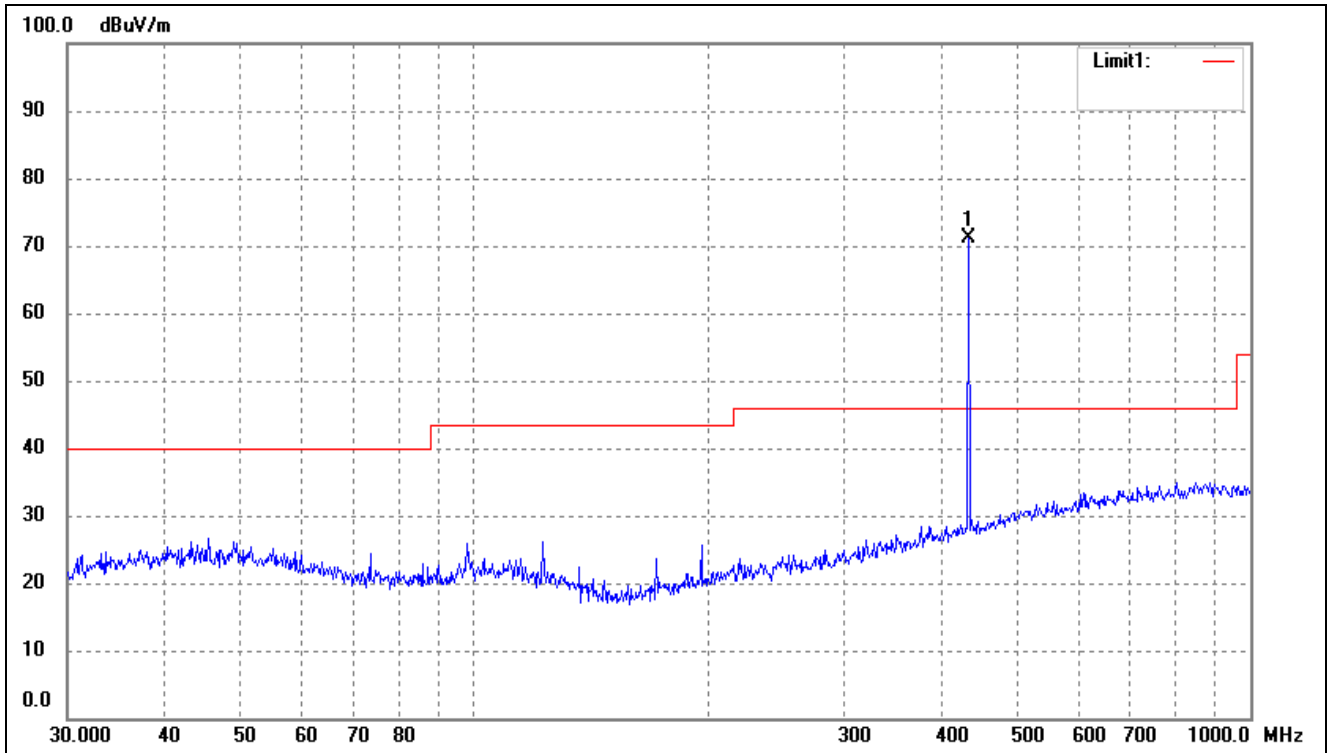

No.	Frequency MHz	Reading dBuV/m	Corr. Factor (dB)	Dutycycle Factor (dB)	Result dBuV/m	Limit dBuV/m	Margin (dB)	Deg. (°)	Height (cm)	Remark
1	433.9651	73.95	-2.74	N/A	71.21	100.83	-29.62	-	-	peak
/	/	/	/	-9.76	61.45	80.83	-19.38	-	-	Ave

Above 1GHz

No.	Frequency MHz	Reading dBuV/m	Corr. Factor (dB)	Dutycycle Factor (dB)	Result dBuV/m	Limit dBuV/m	Margin dB	Deg. (°)	Height (cm)	Remark
1	1493.846	54.57	-11.61	42.96	74.00	-31.04	-21.23	-	-	Peak
2	2325.462	53.78	-8.72	45.06	74.00	-28.94	-11.56	-	-	Peak
3	4245.883	53.66	-4.59	49.07	74.00	-24.93	-25.88	-	-	Peak

Test Mode	TM2	Polarity:	Horizontal
-----------	-----	-----------	------------

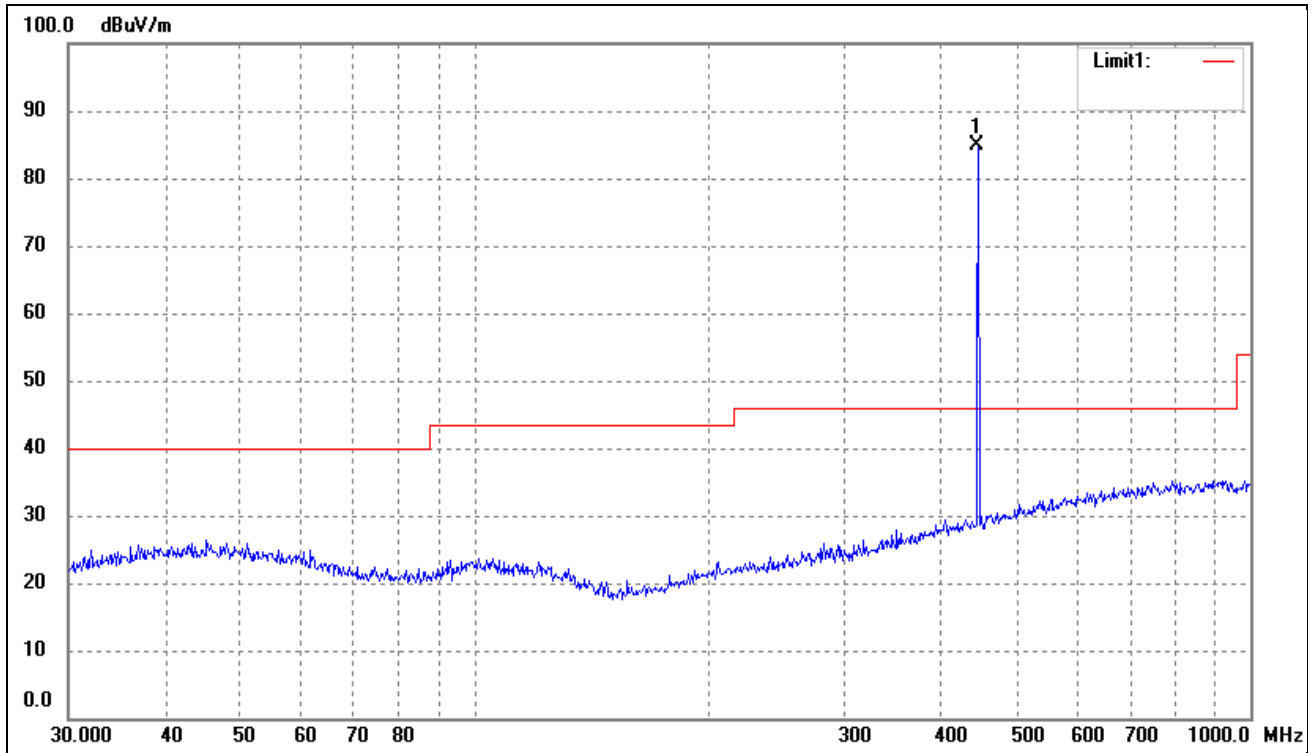

No.	Frequency MHz	Reading dBuV/m	Corr. Factor (dB)	Dutycycle Factor (dB)	Result dBuV/m	Limit dBuV/m	Margin (dB)	Deg. (°)	Height (cm)	Remark
1	443.9500	87.36	-2.50	N/A	84.86	101.15	-16.29	-	-	peak
/	/	/	/	-9.76	75.10	81.15	-6.05	-	-	Ave

Above 1GHz

No.	Frequency MHz	Reading dBuV/m	Corr. Factor (dB)	Result dBuV/m	Limit dBuV/m	Margin dB	Deg. (°)	Height (cm)	Remark
1	1842.254	52.93	-10.44	42.49	74.00	-31.51	-	-	Peak
2	3204.781	51.97	-6.72	45.25	74.00	-28.75	-	-	Peak
3	5124.765	50.29	-2.28	48.01	74.00	-25.99	-	-	Peak

Test Mode	TM2	Polarity:	Vertical
-----------	-----	-----------	----------

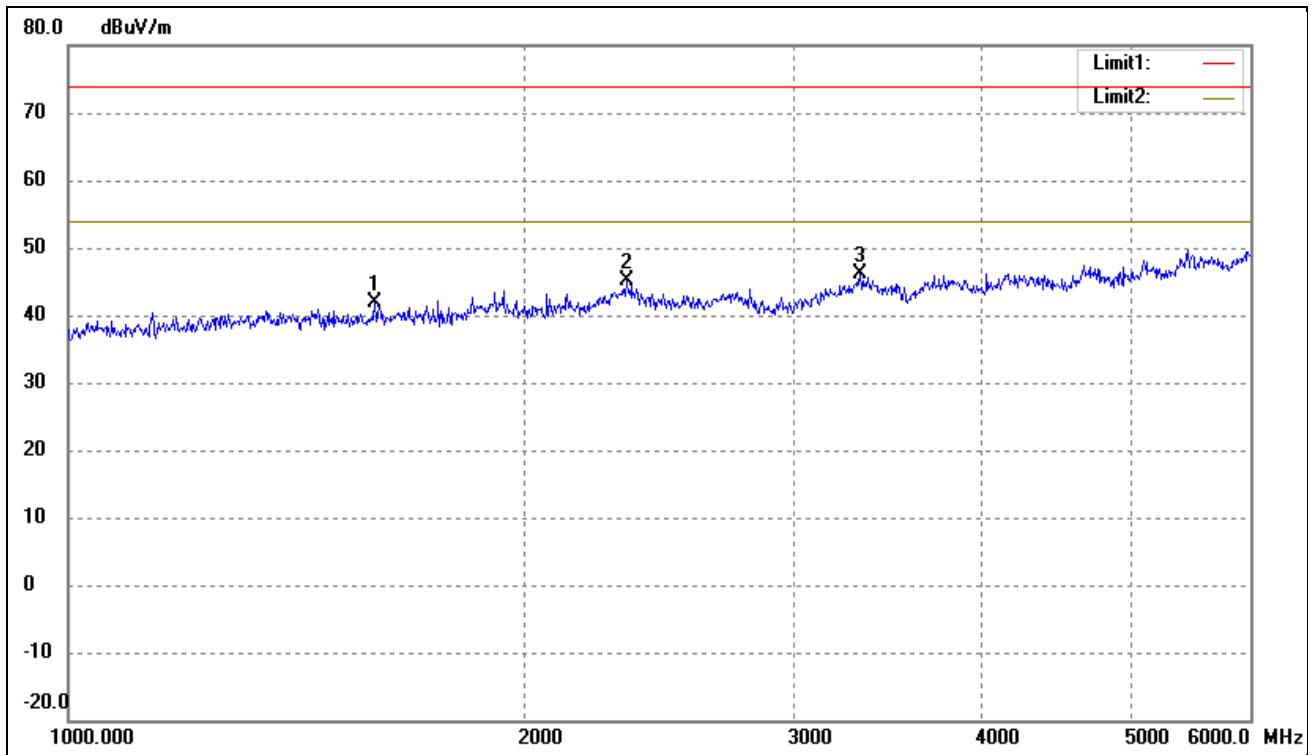

No.	Frequency MHz	Reading dBuV/m	Corr. Factor (dB)	Dutycycle Factor (dB)	Result dBuV/m	Limit dBuV/m	Margin (dB)	Deg. (°)	Height (cm)	Remark
1	443.9651	78.00	-2.50	N/A	75.50	101.15	-25.65	-	-	peak
/	/	/	/	-9.76	65.74	81.15	-15.41	-	-	Ave

Above 1GHz

No.	Frequency MHz	Reading dBuV/m	Corr. Factor (dB)	Result dBuV/m	Limit dBuV/m	Margin dB	Deg. (°)	Height (cm)	Remark
1	1590.527	53.08	-11.28	41.80	74.00	-32.20	-	-	Peak
2	2329.632	53.85	-8.70	45.15	74.00	-28.85	-	-	Peak
3	3321.707	52.31	-6.30	46.01	74.00	-27.99	-	-	Peak

Note: Testing is carried out with frequency rang 9kHz to the tenth harmonics, other than listed in the table above are attenuated more than 20dB below the permissible limits or the field strength is too small to be measured.

5. Duty Cycle

5.1 Standard Applicable

According to FCC Part 15.231 (b)(2) and 15.35 (c), for pulse operation transmitter, the averaging pulsed emissions are calculated by peak value of measured emission plus duty cycle factor.

5.2 Test Procedure

With the EUT's antenna attached, the EUT's output signal was received by the test antenna, which was connected to the spectrum analyzer. Set the center frequency to 433.97MHz, than set the spectrum analyzer to Zero Span for the release time reading. During the testing, the switch was released then the EUT automatically deactivated.

5.3 Summary of Test Results/Plots

433.97MHz:

Type of Pulse	Width of Pulse (ms)	Quantity of Pulse	Transmission Time (ms)
Pulse 1 (Wide)	32.5	1	32.5

Test Period (T _p)	Total Time (T _{on})	Duty Cycle	Duty Cycle Factor
ms	ms	%	dB
100	32.5	32.5	-9.76

Remark: Duty Cycle Factor=20*log(Duty Cycle)

Please refer to the attached test plots:



APPENDIX PHOTOGRAPHS

Please refer to "ANNEX"

**** END OF REPORT ****