

ELECTROMAGNETIC EMISSIONS COMPLIANCE REPORT
INTENTIONAL RADIATOR CERTIFICATION TO
FCC PART 15 SUBPART C

Product Name: Wireless charger

MODEL No.: XTCG011

Trademark: N/A

FCC ID: 2ASHX-XTCG011

REPORT NO.: ES190125030W01

ISSUE DATE: March 26, 2019

Prepared for

BEL USA,LLC.

12610 NW 115 Avenue, Bldg. 200 Medley, FL 33178, USA

Prepared by

EMTEK (SHENZHEN) CO., LTD.

Bldg 69, Majialong Industry Zone, Nanshan District, Shenzhen,
Guangdong, China

TEL: 86-755-26954280

FAX: 86-755-26954282

TABLE OF CONTENT

Test Report Description	Page
1. SUMMARY OF TEST RESULTS.....	5
2. GENERAL INFORMATION	6
2.1. Description of Device (EUT)	6
2.2. Input / Output Ports.....	6
2.3. Independent Operation Modes	7
2.4. Description of Test Facility	7
2.5. Test Software	7
2.6. Description of Support Device	8
2.7. Measurement Uncertainty.....	8
3. MEASURING DEVICE AND TEST EQUIPMENT	9
3.1. For Power Line Conducted Emission Measurement.....	9
3.2. For Radiated Emission Measurement	9
4. 20 DB BANDWIDTH	10
4.1. Block Diagram of Test Setup	10
4.2. Test set-up	10
4.3. Test Results	10
5. POWER LINE CONDUCTED EMISSION MEASUREMENT	11
5.1. Block Diagram of Test Setup	11
5.2. Limits.....	11
5.3. Test Procedure.....	11
5.4. Measuring Results	12
6. RADIATED EMISSION TEST.....	17
6.1. Measurement Procedure	17
6.2. Test SET-UP (Block Diagram of Configuration).....	17
6.3. Measurement Equipment Used	18
6.4. Radiated Emission Limit	18
6.5. Measurement Result.....	20
7. PHOTOS OF SETUP.....	26

TEST REPORT DESCRIPTION

Applicant : BEL USA,LLC.
12610 NW 115 Avenue, Bldg. 200 Medley, FL 33178, USA

Manufacturer : JMTEK Technology Co., Limited
14G, Innovation Tech building, Quanzhi Science and Technology
innovation Park, Shajin Street, Bao'an District, Shenzhen, China

Trade Mark : N/A

EUT : Wireless charger

Model No. : XTCG011

We hereby certify that:

The above equipment was tested by EMTEK (SHENZHEN) CO., LTD. The test data, data evaluation, test procedures, and equipment configurations shown in this report were made in accordance with the procedures given in ANSI C63.10 (2013) and the energy emitted by the sample EUT tested as described in this report is in compliance with conducted and radiated emission limits of FCC Rules Part 15C

The test results of this report relate only to the tested sample identified in this report.

Date of Test : January 25, 2019 to March 22, 2019

Prepared by : 
Yaping Shen/Editor

Reviewer : 
Joe Xia/Supervisor

Approved & Authorized Signer : 
Lisa Wang/Manager



Modified Information

Version	Report No.	Revision Data	Summary
Ver.1.0	ES190125030W01	/	Original Version

1. SUMMARY OF TEST RESULTS

EMISSION		
Description of Test Item	Standard & Limits	Results
Conducted Emission	FCC Part 15, Subpart C- Section 15.207 ANSI C63.10-2013	Pass
Radiated Emission	FCC Part 15, Subpart C- Section 15.209 ANSI C63.10-2013	Pass
20 dB Bandwidth	FCC Part 15, Subpart C- Section 15.215	Pass
Antenna Requirement	FCC Part 15, Subpart C- Section 15.203	Pass (See Notes)
Notes: The EUT uses an Integral Antenna which in accordance to Section 15.203 is considered sufficient to comply with the provisions of this section.		

2. GENERAL INFORMATION

2.1. Description of Device (EUT)

EUT	:	Wireless charger
Model Number	:	XTCG011
Power Supply	:	Input: DC 5V 2A Output: DC 5V 1000mA Max
Operating Frequency	:	112-205KHz
Modulation Technique	:	Induction
Classification	:	Type 3 (Category I Radio Apparatus)
Antenna Type	:	Integral Antenna(Induction coil)
Date of Received	:	January 25, 2019
Date of Test	:	January 25, 2019 to March 22, 2019

2.2. Input / Output Ports

Port #	Name	Type*	Cable Max. >3m	Cable Shielded	Comments
1	Enclosure	N/E	--	--	None
2	Type-C port	I/O	No	Shielded(1.2m)	1 ports
<p>* Note: For the purposes of the present document, the following symbols apply:</p> <p>AC AC Power Port DC DC Power Port N/E Non-Electrical I/O Signal Input or Output Port (Not Involved in Process Control) TP Telecommunication Ports</p>					

2.3. Independent Operation Modes

Pertest mode	Description
Mode 1	Standby mode
Mode 2	Mobile phone is charging at 1% battery power
Mode 3	Mobile phone is charging at 50% battery power
Mode 4	Mobile phone is charging at 99% battery power
Note: Only the worst case data is shown in the report.	

2.4. Description of Test Facility

Site Description

EMC Lab. : Accredited by CNAS, 2016.10.24
The certificate is valid until 2022.10.28
The Laboratory has been assessed and proved to be in compliance with
CNAS-CL01:2006 (identical to ISO/IEC 17025:2005)
The Certificate Registration Number is L2291.

Accredited by TUV Rheinland Shenzhen 2016.5.19
The Laboratory has been assessed according to the requirements
ISO/IEC 17025.

Accredited by FCC, August 06, 2018
The certificate is valid until August 07, 2020
Designation Number: CN1204
Test Firm Registration Number: 882943

Accredited by Industry Canada, November 09, 2018
The Conformity Assessment Body Identifier is CN0008.

Accredited by A2LA, July 31, 2017
The Certificate Number is 4321.01.

Name of Firm : EMTEK (SHENZHEN) CO., LTD.

Site Location : Bldg 69, Majialong Industry Zone, Nanshan District, Shenzhen,
Guangdong, China

2.5. Test Software

Item : Software
Conducted Emission : EMTEK(Ver.CON-03A1)-Shenzhen
Radiated Emission : EMTEK(Ver.RA-03A1)-Shenzhen

2.6. Description of Support Device

No.	Equipment	Trade name	Model	S/N	Power Cord
1.	Adapter	BULL	GN-U2000	N/A	N/A

2.7. Measurement Uncertainty

Test Item	Uncertainty
Conducted Emission Uncertainty	3.16dB(9k~150kHz Conduction 2#) 2.90dB(150k-30MHz Conduction 2#)
Radiated Emission Uncertainty (3m Chamber)	3.78dB (30M~1GHz Polarize: H) 4.27dB (30M~1GHz Polarize: V) 4.46dB (1~6GHz)

3. MEASURING DEVICE AND TEST EQUIPMENT

3.1. For Power Line Conducted Emission Measurement

Used	Equipment	Manufacturer	Model No.	Serial No.	Last Cal.	Cal. Interval
<input checked="" type="checkbox"/>	Test Receiver	Rohde & Schwarz	ESCS30	828985/018	May 20, 2018	1 Year
<input checked="" type="checkbox"/>	L.I.S.N.	Rohde & Schwarz	ESH3-Z5	100191	May 20, 2018	1 Year
<input checked="" type="checkbox"/>	50Ω Coaxial Switch	Anritsu	MP59B	M20531	May 20, 2018	1 Year
<input checked="" type="checkbox"/>	Pulse Limiter	Rohde & Schwarz	ESH3-Z2	100006	May 20, 2018	1 Year

3.2. For Radiated Emission Measurement

Used	Equipment	Manufacturer	Model No.	Serial No.	Last Cal.	Cal. Interval
<input checked="" type="checkbox"/>	EMI Test Receiver	Rohde & Schwarz	ESU	1302.6005.26	May 20, 2018	1 Year
<input checked="" type="checkbox"/>	Pre-Amplifier	HP	8447F	2944A07999	May 20, 2018	1 Year
<input checked="" type="checkbox"/>	Bilog Antenna	Schwarzbeck	VULB9163	142	May 20, 2018	1 Year
<input checked="" type="checkbox"/>	Cable	Schwarzbeck	AK9513	ACRX1	May 20, 2018	1 Year
<input checked="" type="checkbox"/>	Cable	Rosenberger	N/A	FP2RX2	May 20, 2018	1 Year
<input checked="" type="checkbox"/>	Cable	Schwarzbeck	AK9513	CRPX1	May 20, 2018	1 Year
<input checked="" type="checkbox"/>	Cable	Schwarzbeck	AK9513	CRRX2	May 20, 2018	1 Year
<input checked="" type="checkbox"/>	EMI Test Receiver	Rohde & Schwarz	ESU	1302.6005.26	May 20, 2018	1 Year
<input checked="" type="checkbox"/>	Pre-Amplifier	A.H.	PAM-0126	1415261	May 20, 2018	1 Year
<input checked="" type="checkbox"/>	Horn Antenna	Schwarzbeck	BBHA 9120	707	May 20, 2018	1 Year
<input checked="" type="checkbox"/>	Cable	H+B	0.5M SF104-26.5	289147/4	May 20, 2018	1 Year
<input checked="" type="checkbox"/>	Cable	H+B	3M SF104-26.5	295838/4	May 20, 2018	1 Year
<input checked="" type="checkbox"/>	Cable	H+B	6M SF104-26.5	295840/4	May 20, 2018	1 Year

4. 20 DB BANDWIDTH

4.1. Block Diagram of Test Setup

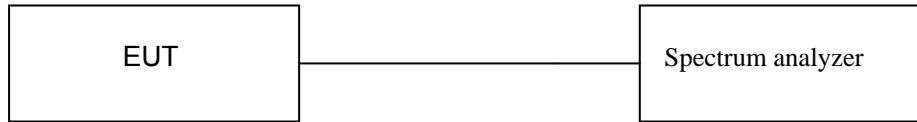

4.2. Test set-up

- Span = approximately 2 to 3 times the 20 dB bandwidth, RBW = greater than 1 % of the 20 dB bandwidth, VBW = RBW, Sweep = auto, Detector = peak, Trace = max hold.
- The marker-to-peak function to set the mark to the peak of the emission. Use the marker-delta function to measure 20 dB down one side of the emission. Reset the function, and move the marker to the other side of the emission, until it is (as close as possible) even with the reference marker level. The marker-delta reading at this point is 20 dB bandwidth of the emission.

4.3. Test Results

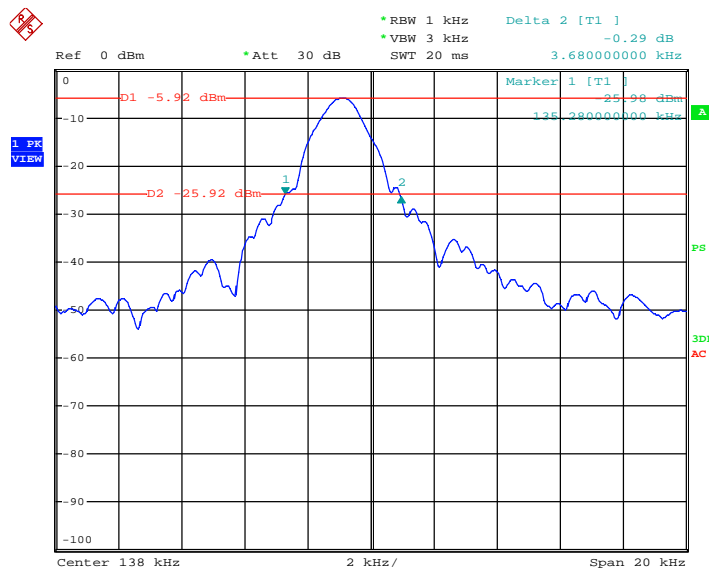

Date: 19.MAR.2019 10:39:27

5. POWER LINE CONDUCTED EMISSION MEASUREMENT

5.1. Block Diagram of Test Setup

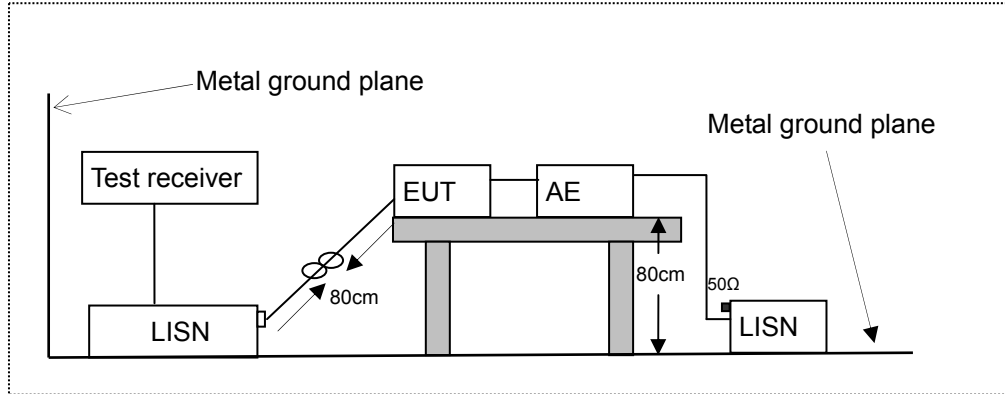

LISN: Line Impedance Stabilization Network
 AE: Associated equipment
 EUT: Equipment under test

5.2. Limits

FCC Part 15.207

Frequency (MHz)	Limit (dB μ V)	
	Quasi-peak Level	Average Level
0.15 ~ 0.50	66.0 ~ 56.0 *	56.0 ~ 46.0 *
0.50 ~ 5.00	56.0	46.0
5.00 ~ 30.00	60.0	50.0

NOTE1-The lower limit shall apply at the transition frequencies.
 NOTE2-The limit decreases linearly with the logarithm of the frequency in the range 0.15MHz to 0.50MHz.

5.3. Test Procedure

The EUT was placed on a desk 0.8 m height from the metal ground plane and 0.4 m from the conducting wall of the shielding room and it was kept at least 0.8 m from any other grounded conducting surface. The size of the table will nominally be 1.5 m x1.0 m.

The rear of the arrangement shall be flush with the back of the supporting tabletop unless that would not be possible or typical of normal use.

All units of equipment forming the system under test (includes the EUT as well as connected peripherals and associated equipment or devices) shall be arranged such that a nominal 0.1 m separation is achieved between the neighboring units.

Connect EUT to the power mains through a line impedance stabilization network (LISN). Where the mains cable supplied by the manufacturer is longer than 1 m, the excess should be folded at the centre into a bundle no longer than 0.4 m, so that its length is shortened to 1 m.

All the support units are connecting to the other LISN.

The LISN provides 50 ohm coupling impedance for the measuring instrument.

Both sides of AC line were checked for maximum conducted interference.

The frequency range from 150 kHz to 30 MHz was sweep.

Set the test-receiver system to quasi peak detect function and average detect function, and to measure the conducted emissions values.

Test results were obtained from the following equation:

Emission Level (dB μ V) = LISN Factor (dB) + Cable Loss (dB) + Reading (dB μ V)

Margin (dB) = Emission Level (dB μ V) - Limit (dB μ V)

5.4. Measuring Results

PASS.

Worst Case Operating Mode: Mode 2

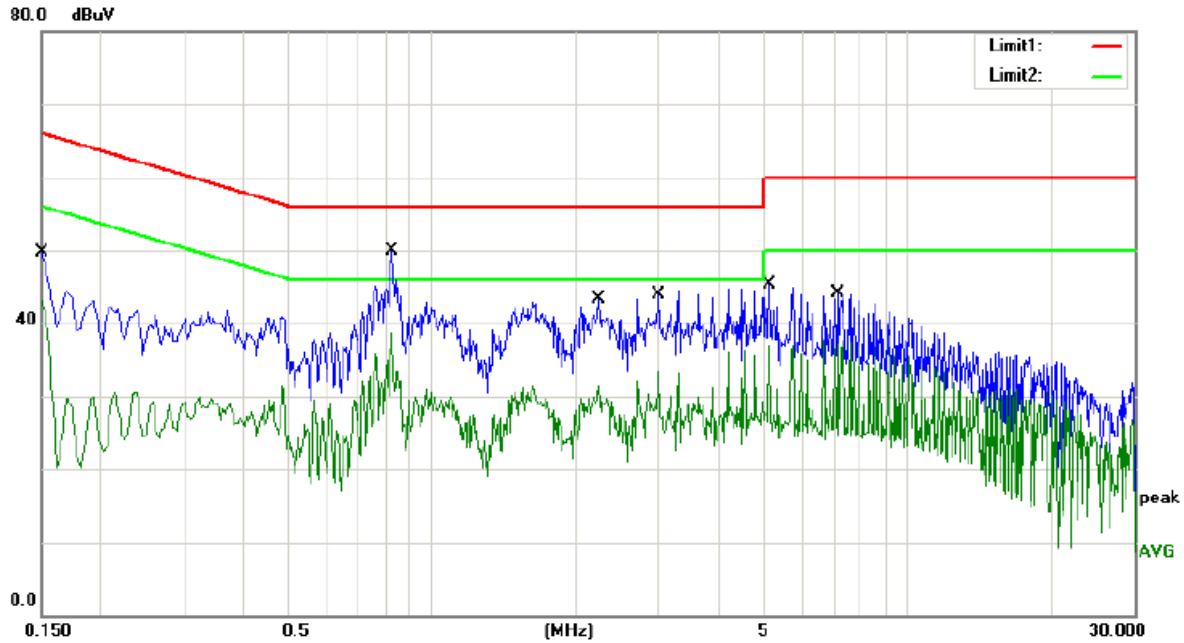

Site site #1 Phase: **L1** Temperature: 18
 Limit: (CE)FCC PART 15 class B_QP Power: AC 240V/60Hz Humidity: 43 %
 Mode: Mode 2
 Note:

No.	Mk.	Freq.	Reading Level	Correct Factor	Measurement	Limit	Over	Detector	Comment
		MHz	dBuV	dB	dBuV	dBuV	dB		
1		0.1500	39.60	10.10	49.70	66.00	-16.30	QP	
2		0.1500	33.00	10.10	43.10	56.00	-12.90	AVG	
3	*	0.8180	39.80	10.02	49.82	56.00	-6.18	QP	
4		0.8180	28.10	10.02	38.12	46.00	-7.88	AVG	
5		2.2460	33.20	10.13	43.33	56.00	-12.67	QP	
6		2.2460	21.40	10.13	31.53	46.00	-14.47	AVG	
7		2.9940	33.70	10.19	43.89	56.00	-12.11	QP	
8		2.9940	23.30	10.19	33.49	46.00	-12.51	AVG	
9		5.1360	35.00	10.35	45.35	60.00	-14.65	QP	
10		5.1360	26.50	10.35	36.85	50.00	-13.15	AVG	
11		7.1160	33.60	10.41	44.01	60.00	-15.99	QP	
12		7.1160	14.30	10.41	24.71	50.00	-25.29	AVG	

*:Maximum data x:Over limit !:over margin Comment: Factor build in receiver. Operator: YYF

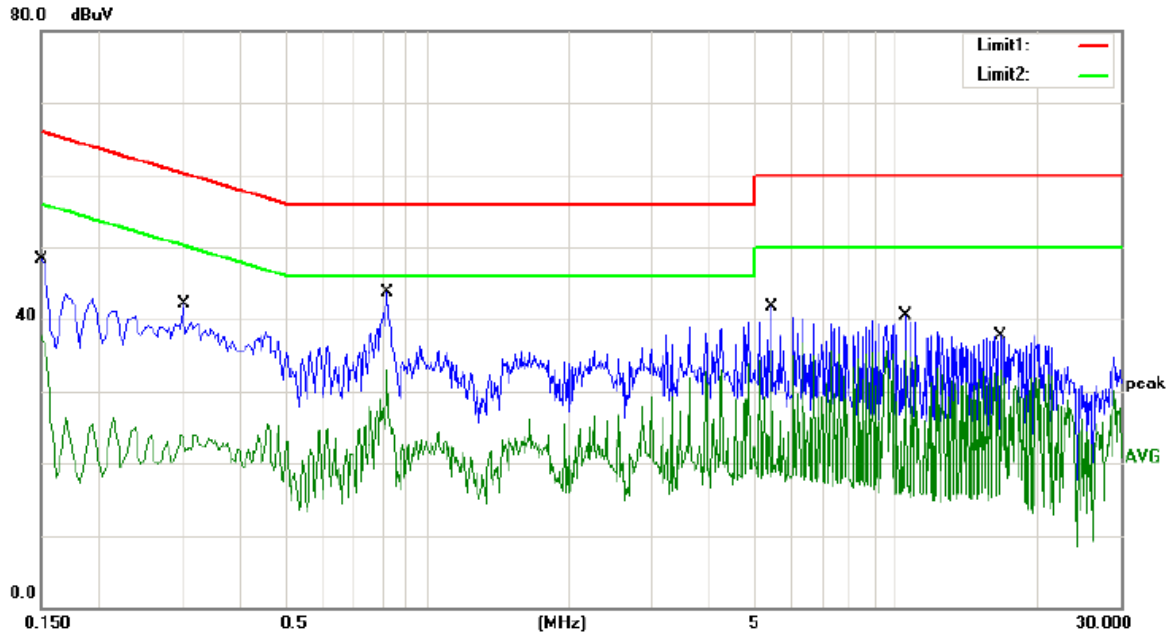

Site site #1 Phase: **N** Temperature: 18
 Limit: (CE)FCC PART 15 class B_QP Power: AC 240V/60Hz Humidity: 43 %
 Mode: Mode 2
 Note:

No.	Mk.	Freq.	Reading Level	Correct Factor	Measurement	Limit	Over	Detector	Comment
		MHz	dBuV	dB	dBuV	dBuV	dB		
1		0.1500	38.20	10.10	48.30	66.00	-17.70	QP	
2		0.1500	27.50	10.10	37.60	56.00	-18.40	AVG	
3		0.3020	32.00	10.08	42.08	60.19	-18.11	QP	
4		0.3020	12.80	10.08	22.88	50.19	-27.31	AVG	
5	*	0.8220	33.70	10.02	43.72	56.00	-12.28	QP	
6		0.8220	22.80	10.02	32.82	46.00	-13.18	AVG	
7		5.4320	31.20	10.36	41.56	60.00	-18.44	QP	
8		5.4320	25.40	10.36	35.76	50.00	-14.24	AVG	
9		10.4080	29.90	10.49	40.39	60.00	-19.61	QP	
10		10.4080	17.80	10.49	28.29	50.00	-21.71	AVG	
11		16.7440	27.00	10.57	37.57	60.00	-22.43	QP	
12		16.7440	22.30	10.57	32.87	50.00	-17.13	AVG	

*:Maximum data x:Over limit !:over margin Comment: Factor build in receiver. Operator: YYF

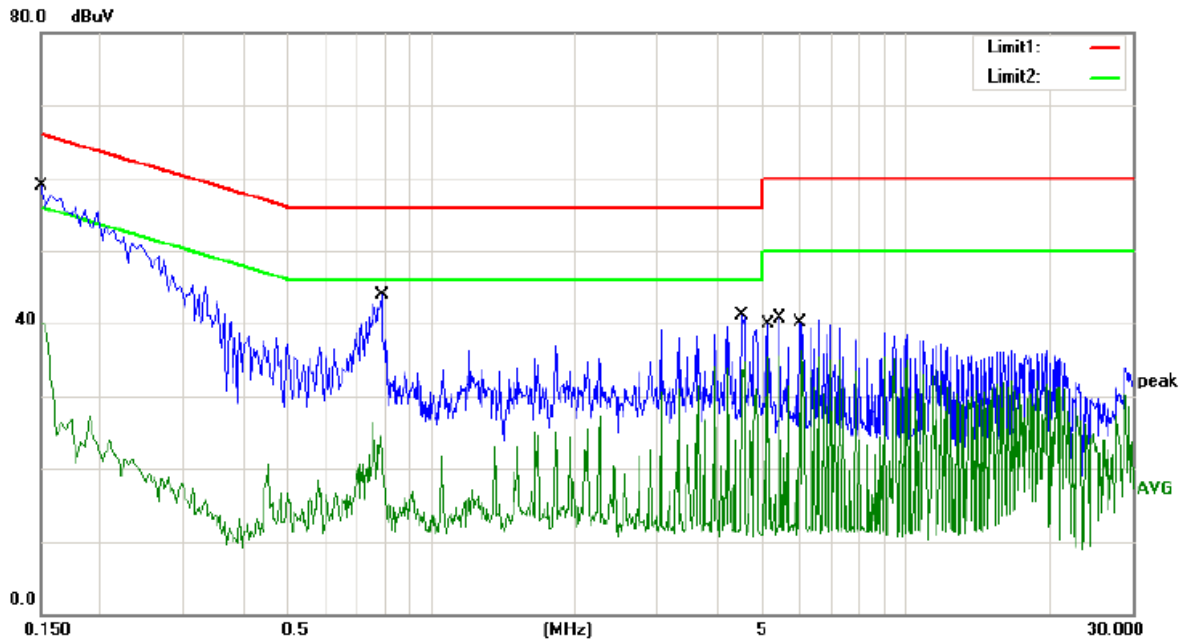

Site site #1 Phase: **N** Temperature: 18
 Limit: (CE)FCC PART 15 class B_QP Power: AC 120V/60Hz Humidity: 43 %
 Mode: Mode 2
 Note:

No.	Mk.	Freq. MHz	Reading Level dBuV	Correct Factor dB	Measure- ment dBuV	Limit dBuV	Over dB	Detector	Comment
1	*	0.1500	48.70	10.10	58.80	66.00	-7.20	QP	
2		0.1500	30.10	10.10	40.20	56.00	-15.80	AVG	
3		0.7820	33.80	10.02	43.82	56.00	-12.18	QP	
4		0.7820	14.40	10.02	24.42	46.00	-21.58	AVG	
5		4.5660	24.40	10.32	34.72	56.00	-21.28	QP	
6		4.5660	18.20	10.32	28.52	46.00	-17.48	AVG	
7		5.1280	29.50	10.35	39.85	60.00	-20.15	QP	
8		5.1280	24.80	10.35	35.15	50.00	-14.85	AVG	
9		5.4280	30.30	10.36	40.66	60.00	-19.34	QP	
10		5.4280	25.00	10.36	35.36	50.00	-14.64	AVG	
11		6.0320	29.50	10.38	39.88	60.00	-20.12	QP	
12		6.0320	25.80	10.38	36.18	50.00	-13.82	AVG	

*:Maximum data x:Over limit !:over margin Comment: Factor build in receiver. Operator: YYF

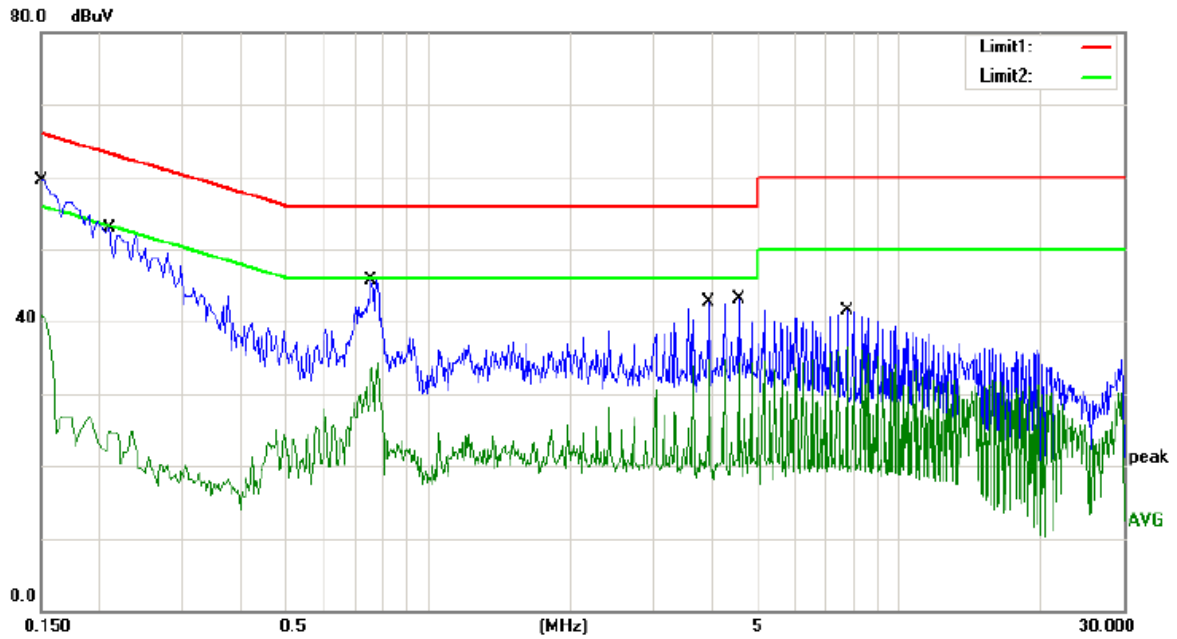

Site site #1 Phase: **L1** Temperature: 18
 Limit: (CE)FCC PART 15 class B_QP Power: AC 120V/60Hz Humidity: 43 %
 Mode: Mode 2
 Note:

No.	Mk.	Freq. MHz	Reading Level dBuV	Correct Factor dB	Measure- ment dBuV	Limit dBuV	Over dB	Detector	Comment
1	*	0.1500	49.30	10.10	59.40	66.00	-6.60	QP	
2		0.1500	30.70	10.10	40.80	56.00	-15.20	AVG	
3		0.2100	42.70	10.09	52.79	63.21	-10.42	QP	
4		0.2100	14.80	10.09	24.89	53.21	-28.32	AVG	
5		0.7580	35.70	10.03	45.73	56.00	-10.27	QP	
6		0.7580	23.20	10.03	33.23	46.00	-12.77	AVG	
7		3.9540	32.40	10.27	42.67	56.00	-13.33	QP	
8		3.9540	24.40	10.27	34.67	46.00	-11.33	AVG	
9		4.5620	32.70	10.31	43.01	56.00	-12.99	QP	
10		4.5620	9.60	10.31	19.91	46.00	-26.09	AVG	
11		7.7520	31.10	10.42	41.52	60.00	-18.48	QP	
12		7.7520	8.80	10.42	19.22	50.00	-30.78	AVG	

*:Maximum data x:Over limit !:over margin Comment: Factor build in receiver. Operator: YYF

6. RADIATED EMISSION TEST

6.1. Measurement Procedure

1. The EUT was placed on a turn table which is 0.8m above ground plane.
2. Maximum procedure was performed on the six highest emissions to ensure EUT compliance.
3. And also, each emission was to be maximized by changing the polarization of receiving antenna both horizontal and vertical.
4. Repeat above procedures until all frequency measured were complete.
5. Average detector is used for 9–90 KHz, 110–490 KHz and Quasi-Peak detector is used for their frequency band. The IF bandwidth used for measurement of radiated signal strength was 10 KHz for emission below 30 MHz and 120 KHz for emission from 30 MHz to 1000 MHz.

6.2. Test SET-UP (Block Diagram of Configuration)

(A) Radiated Emission Test Set-Up, Frequency Below 30MHz

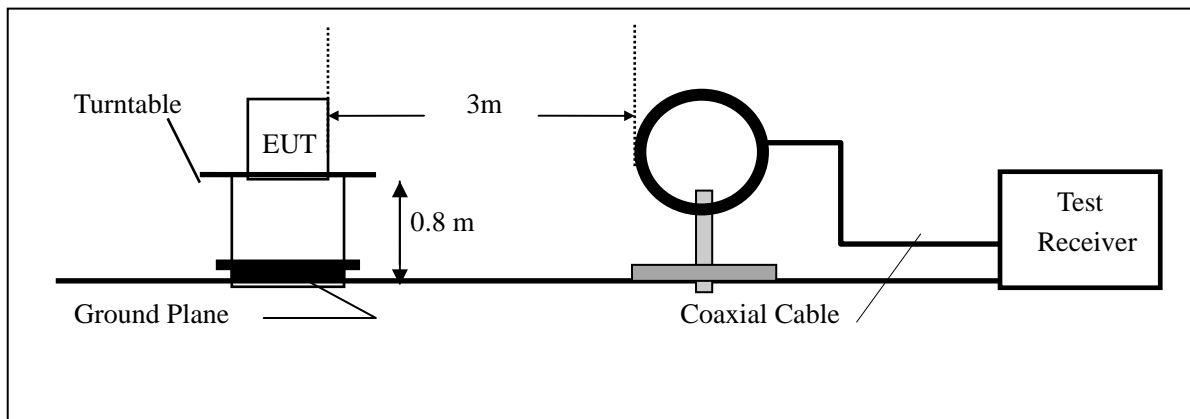

(B) Radiated Emission Test Set-Up, Frequency Below 1000MHz

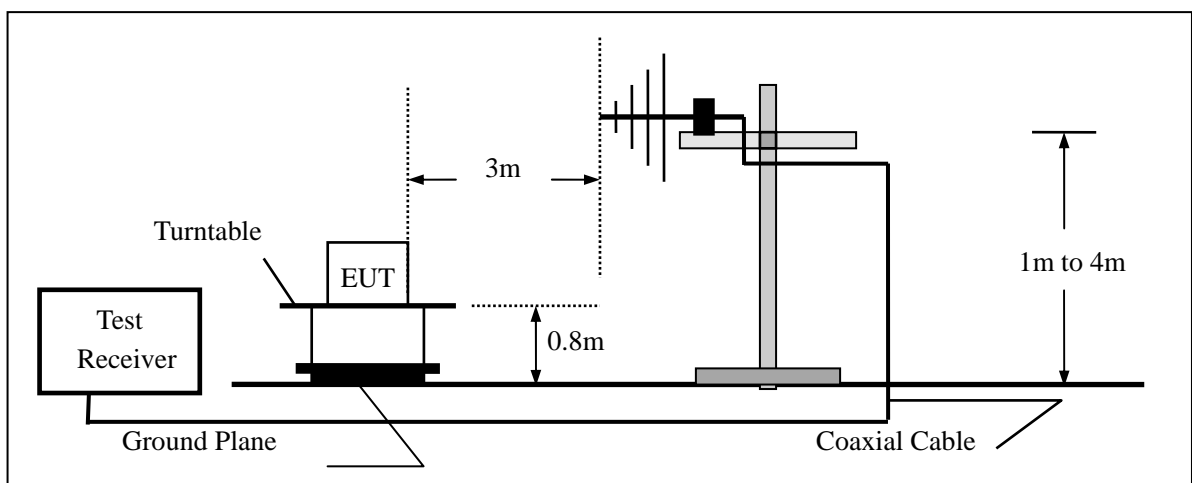

6.3. Measurement Equipment Used

EQUIPMENT TYPE	MFR	MODEL NUMBER	SERIAL NUMBER	LAST CAL.	CAL DUE.
EMI Test Receiver	Rohde & Schwarz	ESU	1302.6005.26	05/20/2018	05/19/2019
Pre-Amplifier	HP	8447D	2944A07999	05/20/2018	05/19/2019
Bilog Antenna	Schwarzbeck	VULB9163	142	05/20/2018	05/19/2019
Loop Antenna	ARA	PLA-1030/B	1029	05/20/2018	05/19/2019
Horn Antenna	Schwarzbeck	BBHA 9170	BBHA9170399	05/20/2018	05/19/2019
Horn Antenna	Schwarzbeck	BBHA 9120	D143	05/20/2018	05/19/2019
Cable	Schwarzbeck	AK9513	ACRX1	05/20/2018	05/19/2019
Cable	Rosenberger	N/A	FP2RX2	05/20/2018	05/19/2019
Cable	Schwarzbeck	AK9513	CRPX1	05/20/2018	05/19/2019
Cable	Schwarzbeck	AK9513	CRRX2	05/20/2018	05/19/2019

6.4. Radiated Emission Limit

The emissions from an intentional radiator shall not exceed the field strength levels specified in the following table 15.209(a):

FCC Part 15.209				
Frequency (MHz)	Field Strength Limitation		Field Strength Limitation Frequency tion at 3m Measurement Dist	
	(uV/m)	Dist	(uV/m)	(dBuV/m)
0.009 – 0.490	2400 / F(KHz)	300m	10000 * 2400/F(KHz)	20log 2400/F(KHz) + 80
0.490 – 1.705	24000 / F(KHz)	30m	100 * 24000/F(KHz)	20log 24000/F(KHz) + 40
1.705 – 30.00	30	30m	100* 30	20log 30 + 40
30.0 – 88.0	100	3m	100	20log 100
88.0 – 216.0	150	3m	150	20log 150
216.0 – 960.0	200	3m	200	20log 200
Above 960.0	500	3m	500	20log 500

15.205 Restricted bands of operation

MHz	MHz	MHz	GHz
0.090 - 0.110	16.42 - 16.423	399.9 - 410	4.5 - 5.15
¹ 0.495 - 0.505	16.69475 - 16.69525	608 - 614	5.35 - 5.46
2.1735 - 2.1905	16.80425 - 16.80475	960 - 1240	7.25 - 7.75
4.125 - 4.128	25.5 - 25.67	1300 - 1427	8.025 - 8.5
4.17725 - 4.17775	37.5 - 38.25	1435 - 1626.5	9.0 - 9.2
4.20725 - 4.20775	73 - 74.6	1645.5 - 1646.5	9.3 - 9.5
6.215 - 6.218	74.8 - 75.2	1660 - 1710	10.6 - 12.7
6.26775 - 6.26825	108 - 121.94	1718.8 - 1722.2	13.25 - 13.4
6.31175 - 6.31225	123 - 138	2200 - 2300	14.47 - 14.5
8.291 - 8.294	149.9 - 150.05	2310 - 2390	15.35 - 16.2
8.362 - 8.366	156.52475 - 156.52525	2483.5 - 2500	17.7 - 21.4
8.37625 - 8.38675	156.7 - 156.9	2690 - 2900	22.01 - 23.12
8.41425 - 8.41475	162.0125 - 167.17	3260 - 3267	23.6 - 24.0
12.29 - 12.293	167.72 - 173.2	3332 - 3339	31.2 - 31.8
12.51975 - 12.52025	240 - 285	3345.8 - 3358	36.43 - 36.5
12.57675 - 12.57725	322 - 335.4	3600 - 4400	(²)

- Remark:
1. Emission level in dBuV/m=20 log (uV/m)
 2. Measurement was performed at an antenna to the closed point of EUT distance of meters.
 3. Only spurious frequency is permitted to locate within the Restricted Bands specified in provision of ξ 15.205, and the emissions located in restricted bands also comply with 15.209 limit.

6.5.Measurement Result

Worst Case Operating Mode: Mode 2

9KHz-30MHz:

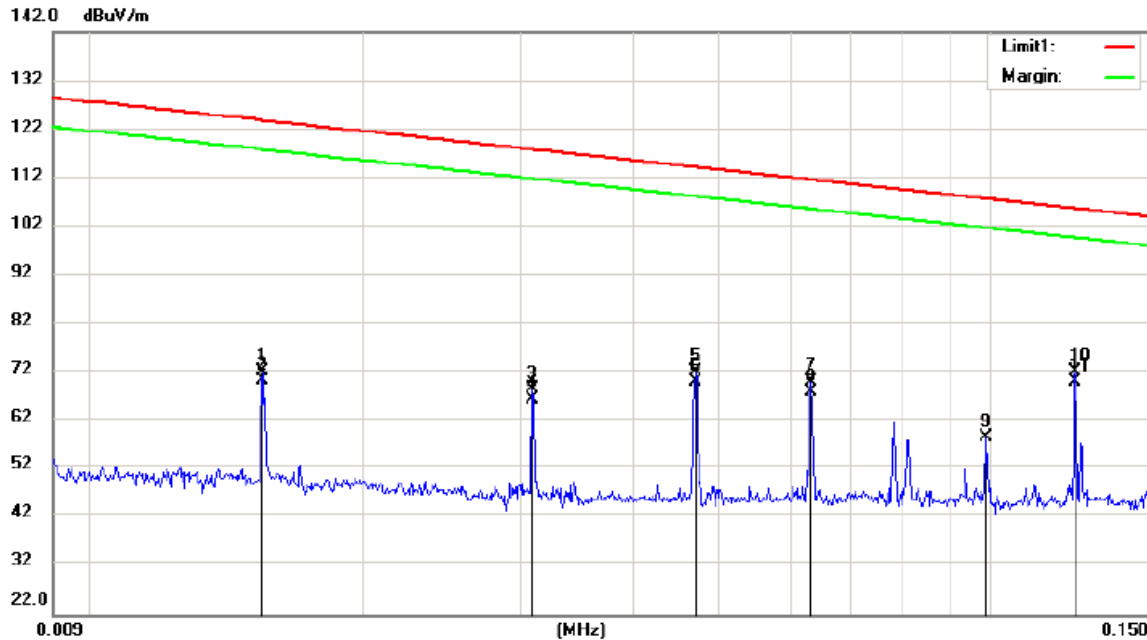

Site site #1
 Limit: (RE)FCC PART 15.209(9K-30M)
 Mode: Mode 2
 Note:

Polarization: **Horizontal**
 Power: AC 120V/60Hz

Temperature: 27 C
 Humidity: 43 %

No.	Mk.	Freq.	Reading	Correct	Measure-	Limit	Over	Antenna	Table	
		MHz	Level	Factor	ment			Height	Degree	
			dBuV	dB	dBuV/m	dBuV/m	dB	cm	degree	Comment
1		0.0154	51.65	20.74	72.39	123.84	-51.45			peak
2		0.0154	49.58	20.74	70.32	123.84	-53.52			AVG
3		0.0308	47.92	20.83	68.75	117.82	-49.07			peak
4		0.0308	45.85	20.83	66.68	117.82	-51.14			AVG
5		0.0470	51.11	21.10	72.21	114.15	-41.94			peak
6		0.0470	49.07	21.10	70.17	114.15	-43.98			AVG
7		0.0630	49.31	20.73	70.04	111.61	-41.57			peak
8		0.0630	47.28	20.73	68.01	111.61	-43.60			AVG
9		0.0990	37.90	20.83	58.73	107.68	-48.95			QP
10	*	0.1243	51.35	20.85	72.20	105.71	-33.51			peak
11		0.1243	49.36	20.85	70.21	105.71	-35.50			AVG

*:Maximum data x:Over limit !:over margin

Operator: KK

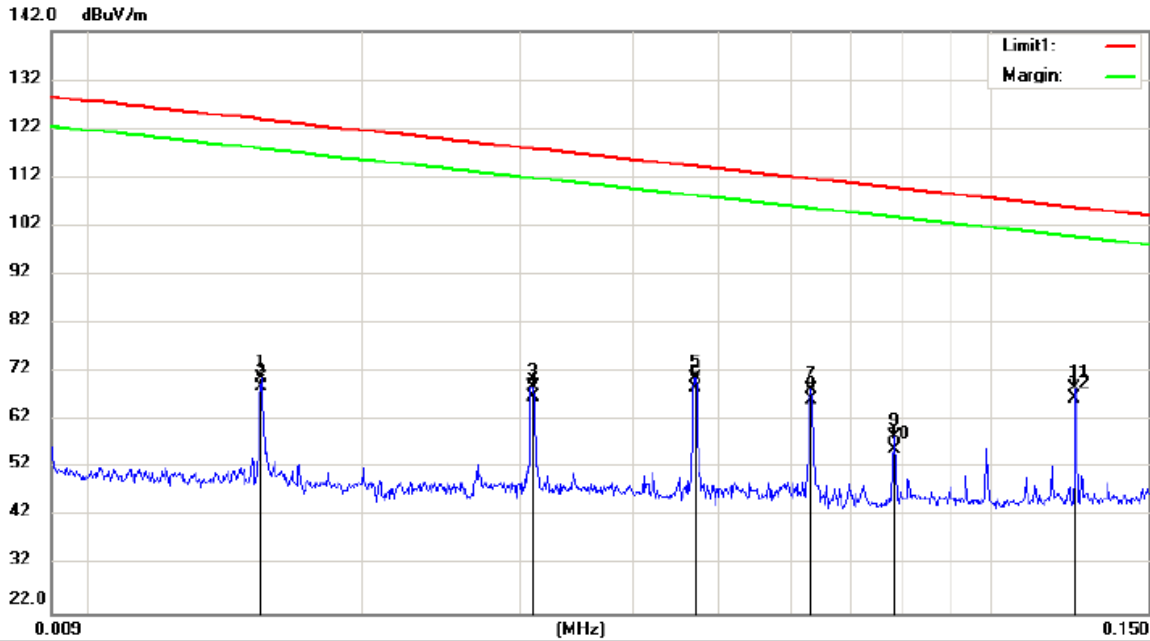

Site site #1 Polarization: **Vertical** Temperature: 27 C
 Limit: (RE)FCC PART 15.209(9K-30M) Power: AC 120V/60Hz Humidity: 43 %
 Mode: Mode 2
 Note:

No.	Mk.	Freq. MHz	Reading Level dBuV	Correct Factor dB	Measure- ment dBuV/m	Limit dBuV/m	Over dB	Antenna Height cm	Table Degree degree	Comment
1		0.0154	50.15	20.74	70.89	123.84	-52.95	peak		
2		0.0154	48.10	20.74	68.84	123.84	-55.00	AVG		
3		0.0310	48.22	20.83	69.05	117.76	-48.71	peak		
4		0.0310	46.06	20.83	66.89	117.76	-50.87	AVG		
5		0.0470	49.61	21.10	70.71	114.15	-43.44	peak		
6		0.0470	47.48	21.10	68.58	114.15	-45.57	AVG		
7		0.0632	47.53	20.73	68.26	111.58	-43.32	peak		
8		0.0632	45.42	20.73	66.15	111.58	-45.43	AVG		
9		0.0780	38.19	20.41	58.60	109.75	-51.15	peak		
10		0.0780	35.60	20.41	56.01	109.75	-53.74	AVG		
11	*	0.1242	47.85	20.85	68.70	105.71	-37.01	peak		
12		0.1242	45.63	20.85	66.48	105.71	-39.23	AVG		

*:Maximum data x:Over limit !:over margin

Operator: KK

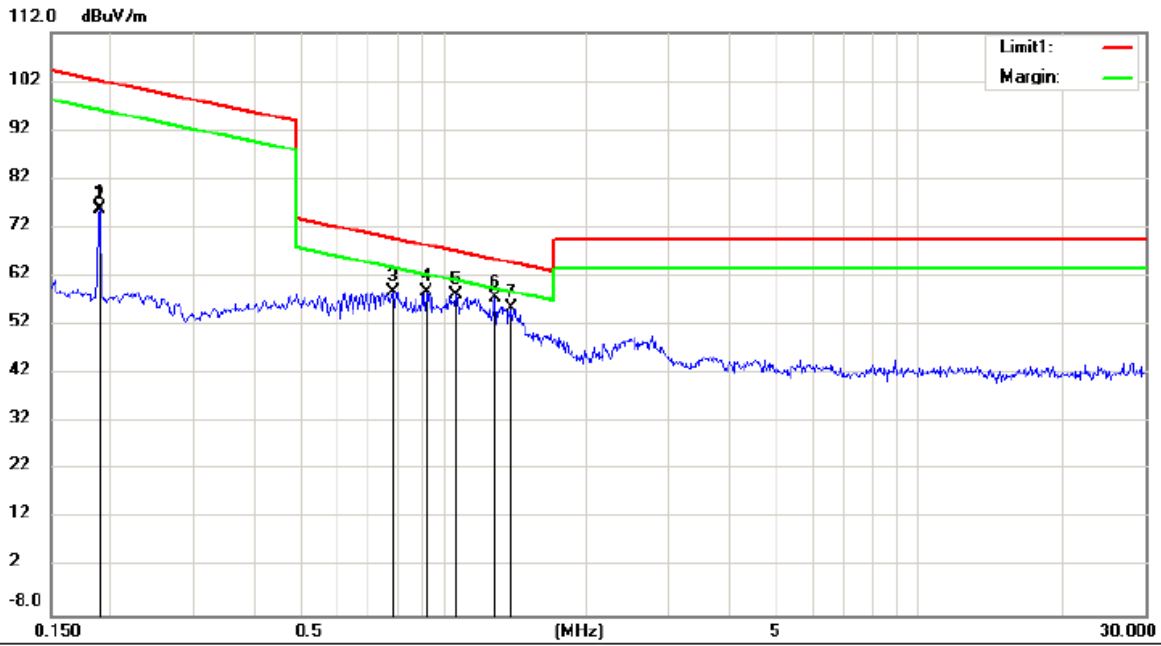

Site site #1 Polarization: **Vertical** Temperature: 27 C
 Limit: (RE)FCC PART 15.209(9K-30M) Power: AC 120V/60Hz Humidity: 43 %
 Mode: Mode 2
 Note:

No.	Mk.	Freq. MHz	Reading Level dBuV	Correct Factor dB	Measure- ment dBuV/m	Limit dBuV/m	Over dB	Antenna Height cm	Table Degree degree	Comment
1		0.1900	54.83	20.93	75.76	102.02	-26.26			peak
2		0.1900	54.75	20.93	75.68	102.02	-26.34			AVG
3		0.7872	37.77	20.96	58.73	69.69	-10.96			QP
4		0.9233	37.82	20.96	58.78	68.31	-9.53			QP
5		1.0650	37.27	20.94	58.21	67.08	-8.87			QP
6	*	1.2890	36.62	20.87	57.49	65.42	-7.93			QP
7		1.3952	34.50	20.84	55.34	64.74	-9.40			QP

*:Maximum data x:Over limit !:over margin

Operator: KK

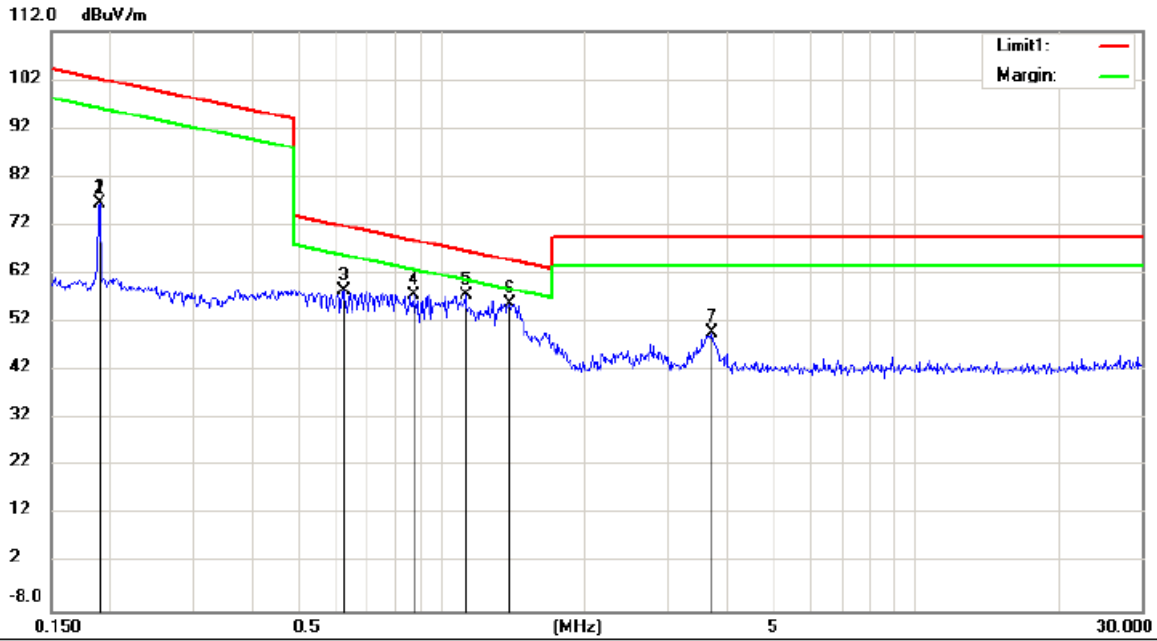

Site site #1 Polarization: **Horizontal** Temperature: 27 C
 Limit: (RE)FCC PART 15.209(9K-30M) Power: AC 120V/60Hz Humidity: 43 %
 Mode: Mode 2
 Note:

No.	Mk.	Freq. MHz	Reading Level dBuV	Correct Factor dB	Measure- ment dBuV/m	Limit dBuV/m	Over dB	Detector	Antenna Height cm	Table Degree	Comment
1		0.1900	55.48	20.93	76.41	102.02	-25.61	peak			
2		0.1900	55.39	20.93	76.32	102.02	-25.70	AVG			
3		0.6205	37.44	21.01	58.45	71.75	-13.30	QP			
4		0.8710	36.72	20.96	57.68	68.82	-11.14	QP			
5		1.1230	36.62	20.92	57.54	66.62	-9.08	QP			
6	*	1.3956	35.00	20.84	55.84	64.73	-8.89	QP			
7		3.7197	29.50	20.39	49.89	69.50	-19.61	QP			

*:Maximum data x:Over limit !:over margin

Operator: KK

30MHz-1GHz:

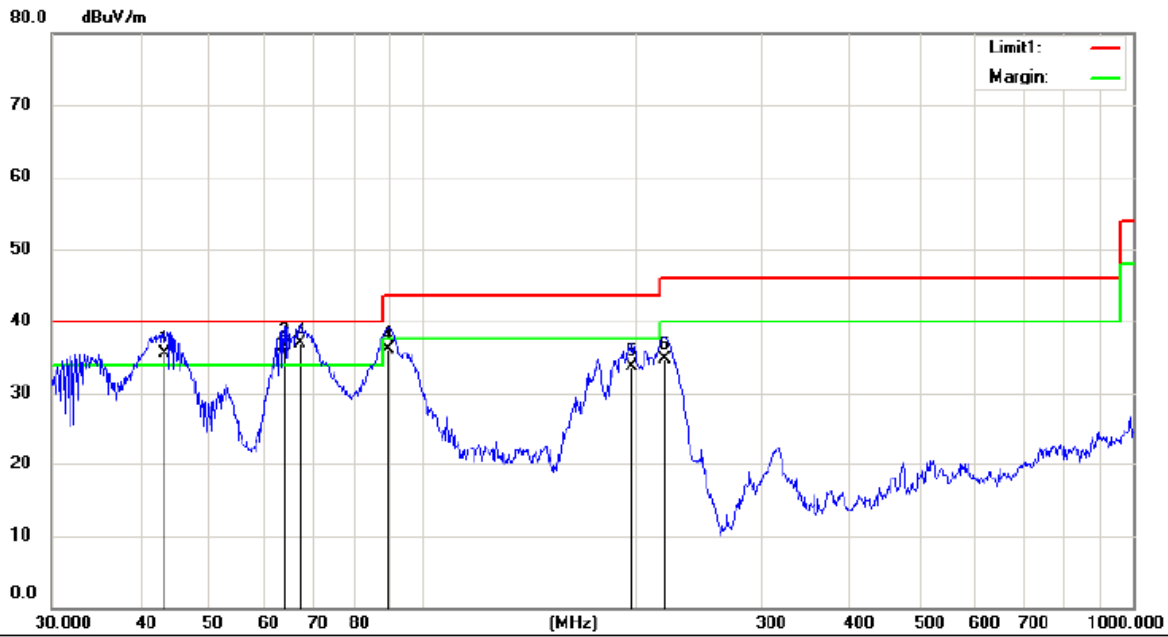

Site site #1

Polarization: **Vertical**

Temperature: 18 C

Limit: FCC Part15 Class B 3M Radiation

Power: AC 120V/60Hz

Humidity: 42 %

Mode: Mode 2

Note:

No.	Mk.	Freq.	Reading Level	Correct Factor	Measurement	Limit	Over	Antenna Height	Table Degree	
		MHz	dBuV	dB	dBuV/m	dBuV/m	dB	cm	degree	Comment
1	!	43.2017	55.62	-20.12	35.50	40.00	-4.50			QP
2	!	63.7588	59.05	-22.55	36.50	40.00	-3.50			QP
3	*	67.2022	60.34	-23.34	37.00	40.00	-3.00			QP
4		89.2764	59.65	-23.55	36.10	43.50	-7.40			QP
5		197.2001	55.88	-22.08	33.80	43.50	-9.70			QP
6		219.0753	56.93	-22.13	34.80	46.00	-11.20			QP

*:Maximum data x:Over limit !:over margin

Operator: KK

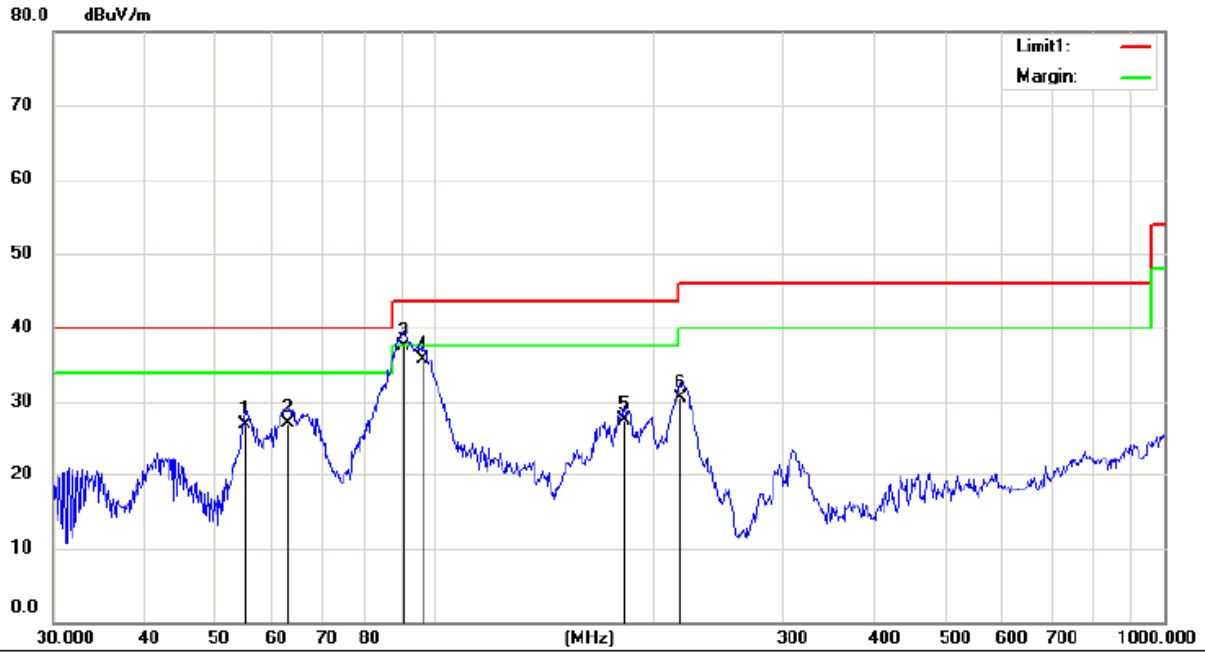

Site site #1 Polarization: **Horizontal** Temperature: 18 C
 Limit: FCC Part15 Class B 3M Radiation Power: AC 120V/60Hz Humidity: 42 %
 Mode: Mode 2
 Note:

No.	Mk.	Freq.	Reading Level	Correct Factor	Measurement	Limit	Over	Antenna Height	Table Degree	
		MHz	dBuV	dB	dBuV/m	dBuV/m	dB	cm	degree	Comment
1		54.8348	46.76	-19.76	27.00	40.00	-13.00			QP
2		62.8708	49.58	-22.38	27.20	40.00	-12.80			QP
3	*	90.5374	60.75	-23.25	37.50	43.50	-6.00			QP
4		96.0986	58.50	-22.70	35.80	43.50	-7.70			QP
5		181.9202	51.68	-24.18	27.50	43.50	-16.00			QP
6		216.7828	52.91	-22.41	30.50	46.00	-15.50			QP

*:Maximum data x:Over limit !:over margin

Operator: KK

7. PHOTOS OF SETUP

CONDUCTED EMISSION TEST



Radiated Measurement Photos

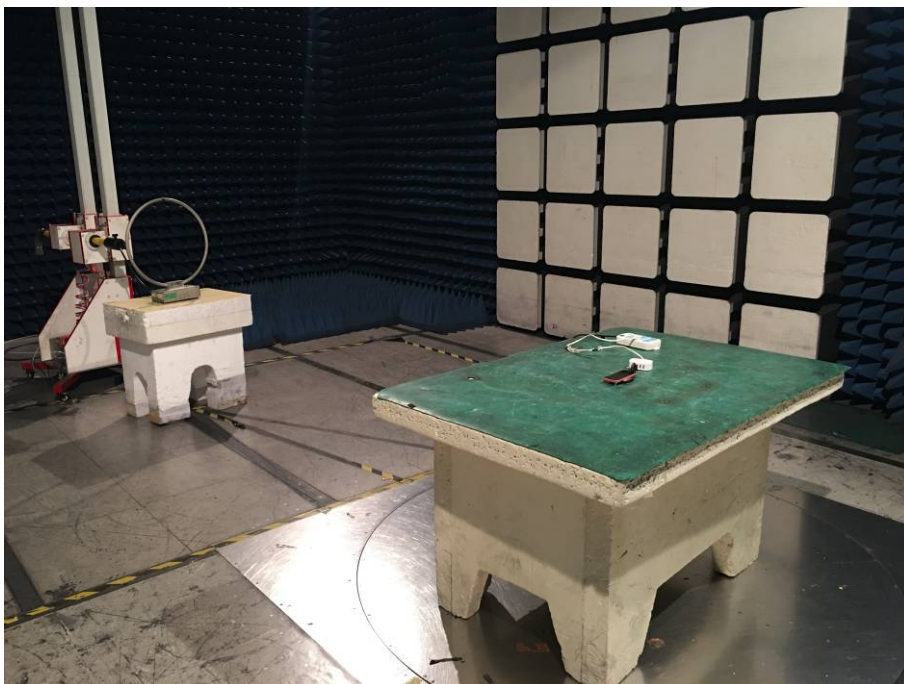
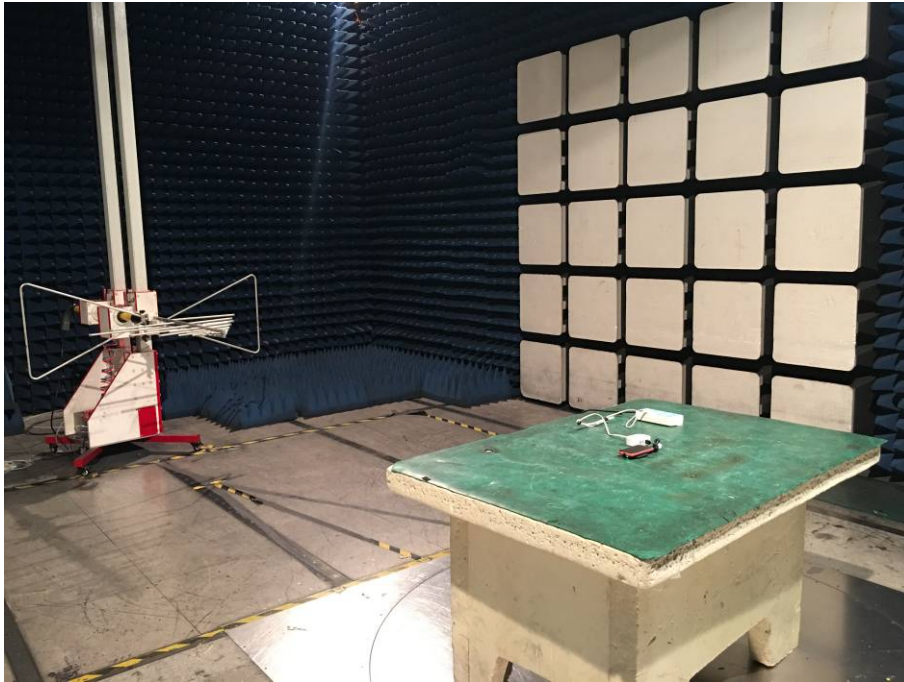

-----The end-----