

## 7. OUT OF BAND EMISSIONS

### RULE PART(S)

FCC: §2.1051, §22.901, §22.917 and §27.53

### LIMITS

The power of any emission outside of the authorized operating frequency ranges must be attenuated below the transmitting power (P) by a factor of at least  $43 + 10 \log (P)$  dB.

### TEST PROCEDURE

The RF output of the transmitter was connected to a spectrum analyzer through a calibrated coaxial cable. Sufficient scans were taken to show the out-of-band Emissions, if any, up to 10th harmonic. Multiple sweeps were recorded in maximum hold mode using a peak detector to ensure that the worst-case emissions were caught.

For each out of band emissions measurement:

- Set display line at -13 dBm
- Set RBW & VBW to 100 kHz for the measurement below 1 GHz, and 1 MHz for the measurement above 1 GHz.

### **MODES TESTED**

- LTE Band 5  
LTE Band 7
- LTE Band 41

### 7.1 MEASUREMENT METHOD

The test set up and general procedure is similar to conducted peak output power test. Only different for setting the measurement configuration of the measuring instrument of Spectrum Analyzer.

### 7.2 LTE BAND 5

*Band 5, UL Channel 20407, UL Frequency 824.7, BW 1.4, NO. RB 6, RB POS. Low, QPSK*

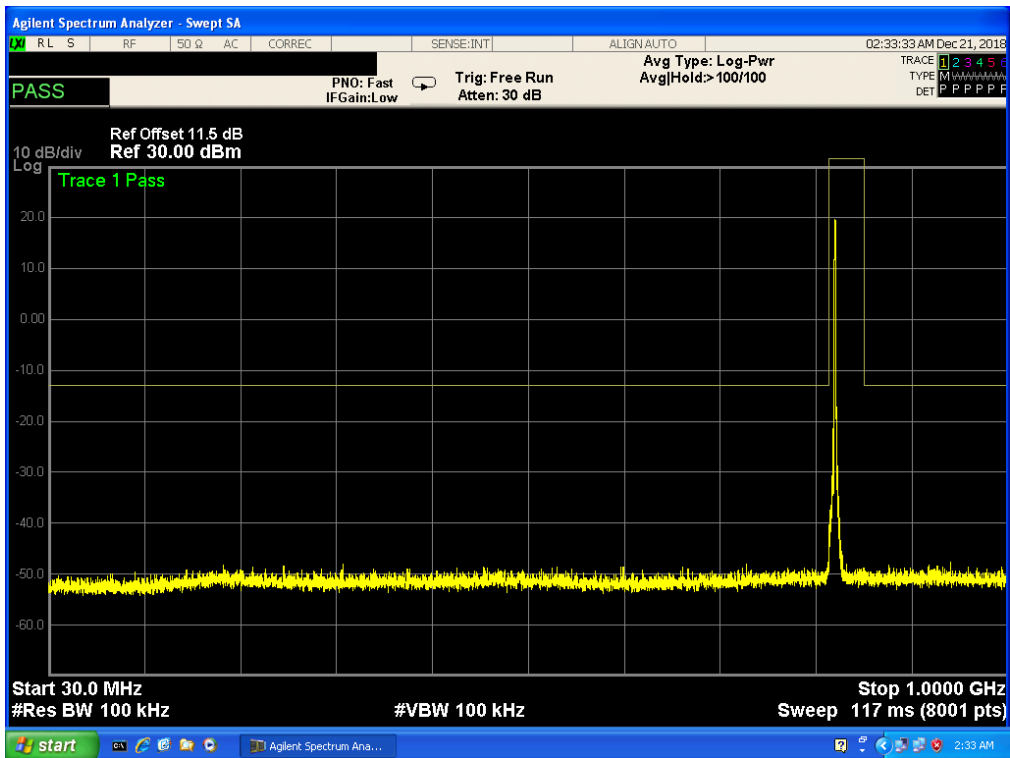

*Band 5, UL Channel 20407, UL Frequency 824.7, BW 1.4, NO. RB 6, RB POS. Low, QPSK*

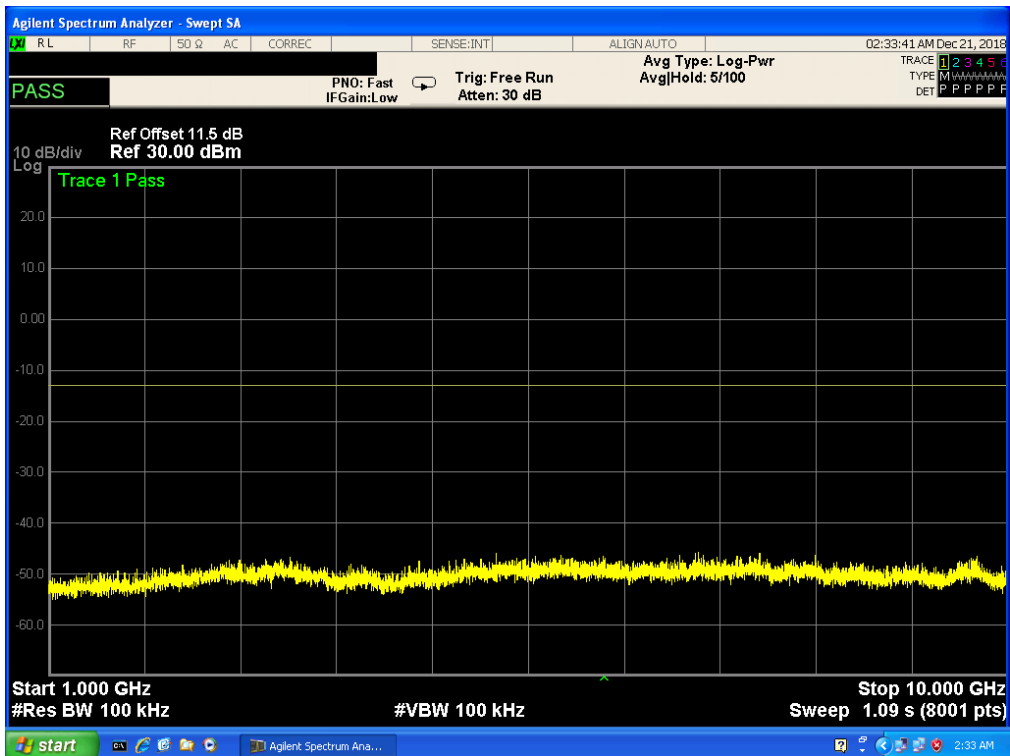

Band 5, UL Channel 20407, UL Frequency 824.7, BW 1.4, NO. RB 6, RB POS. Low, 16-QAM

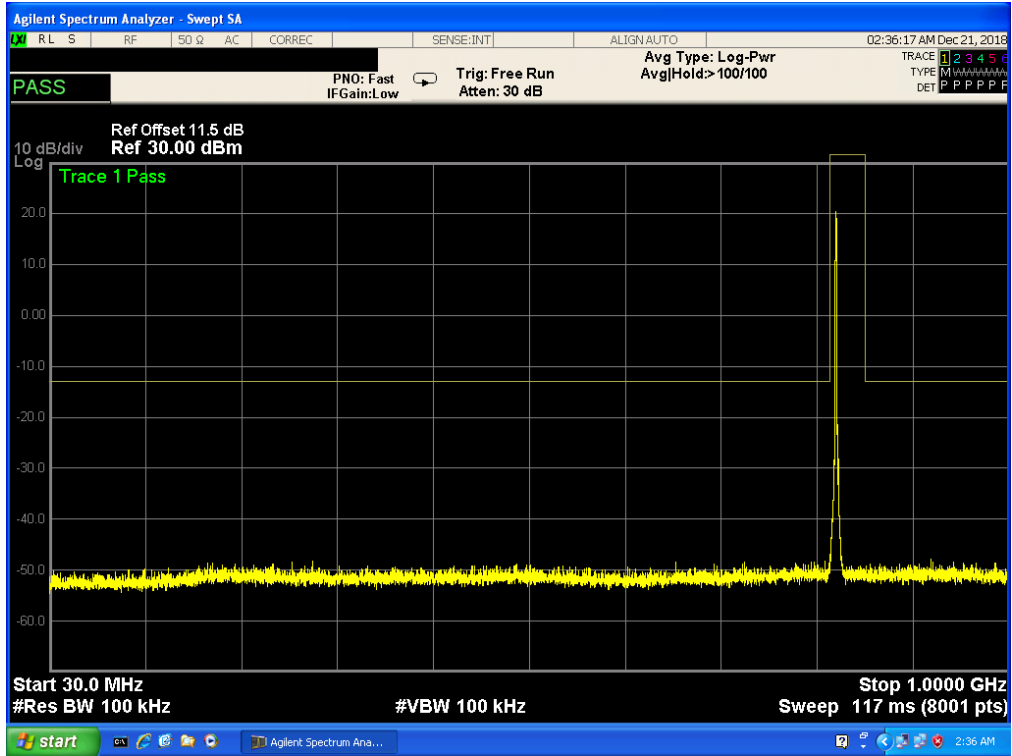

Band 5, UL Channel 20407, UL Frequency 824.7, BW 1.4, NO. RB 6, RB POS. Low, 16-QAM

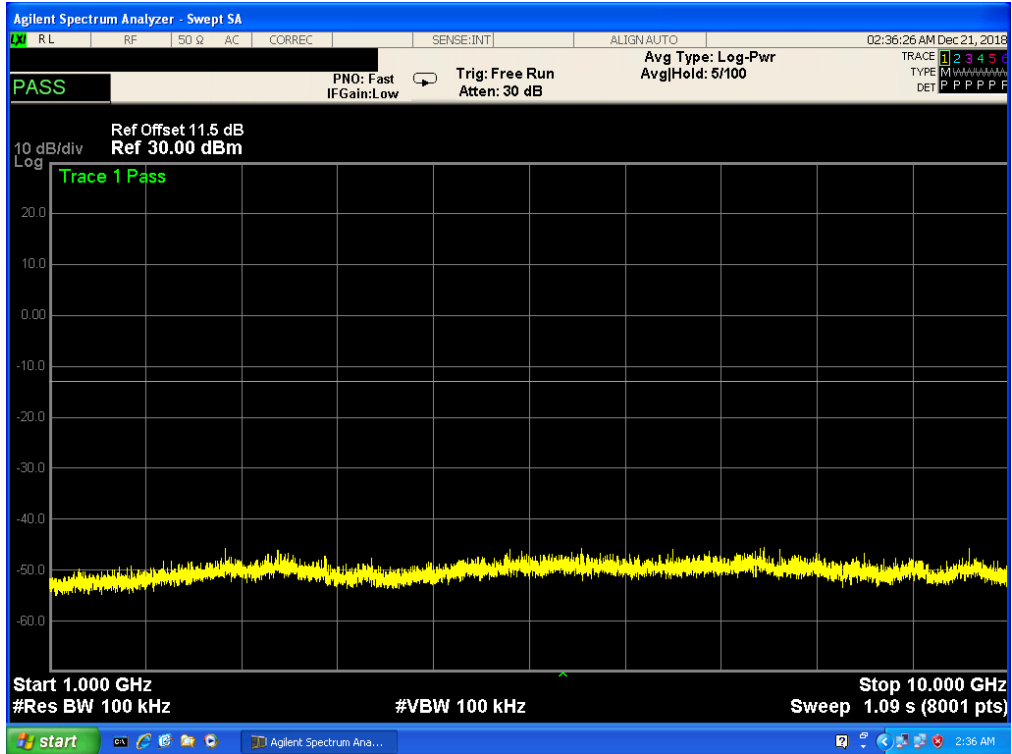

Band 5, UL Channel 20643, UL Frequency 848.3, BW 1.4, NO. RB 6, RB POS. Low, QPSK

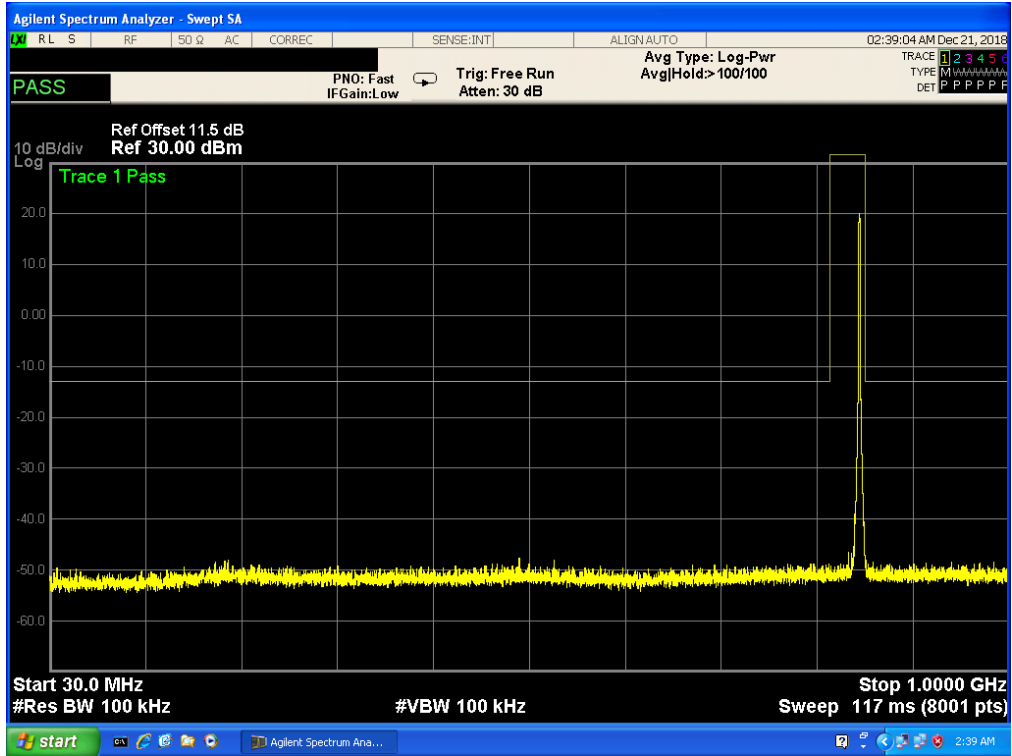

Band 5, UL Channel 20643, UL Frequency 848.3, BW 1.4, NO. RB 6, RB POS. Low, QPSK

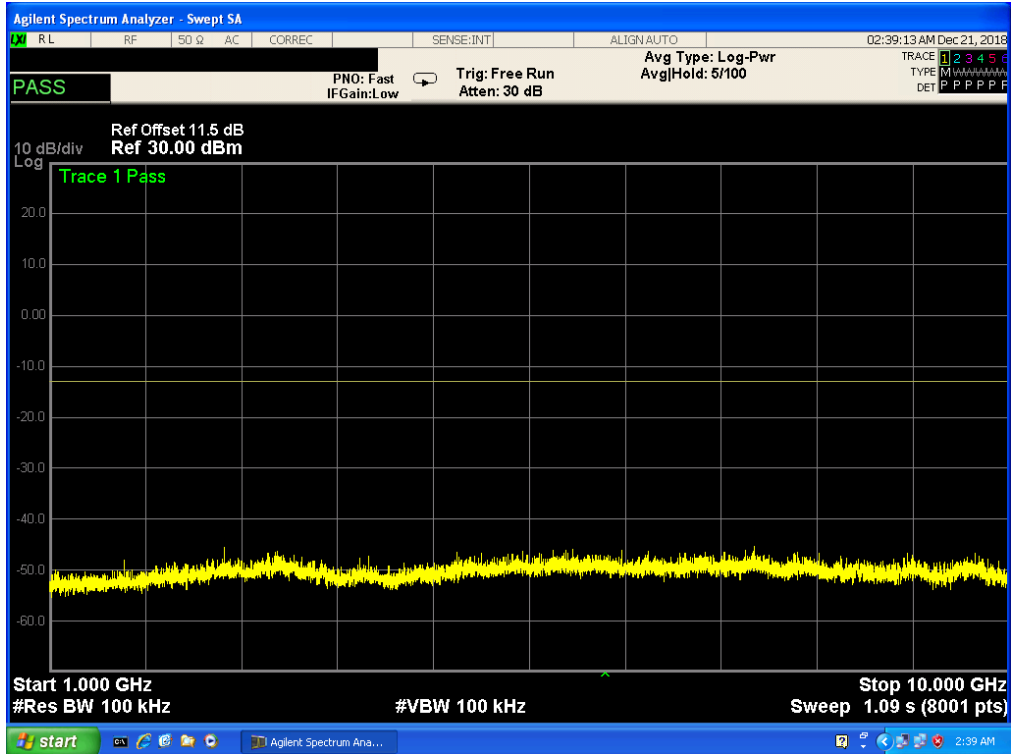

Band 5, UL Channel 20643, UL Frequency 848.3, BW 1.4, NO. RB 6, RB POS. Low, 16-QAM

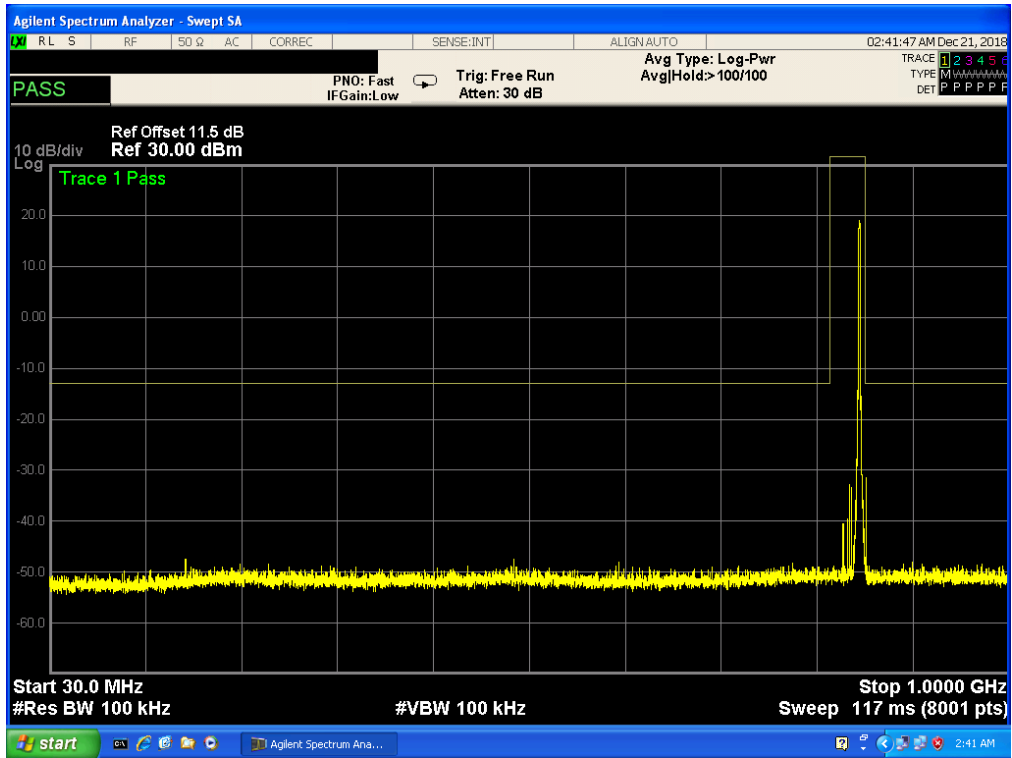

Band 5, UL Channel 20643, UL Frequency 848.3, BW 1.4, NO. RB 6, RB POS. Low, 16-QAM

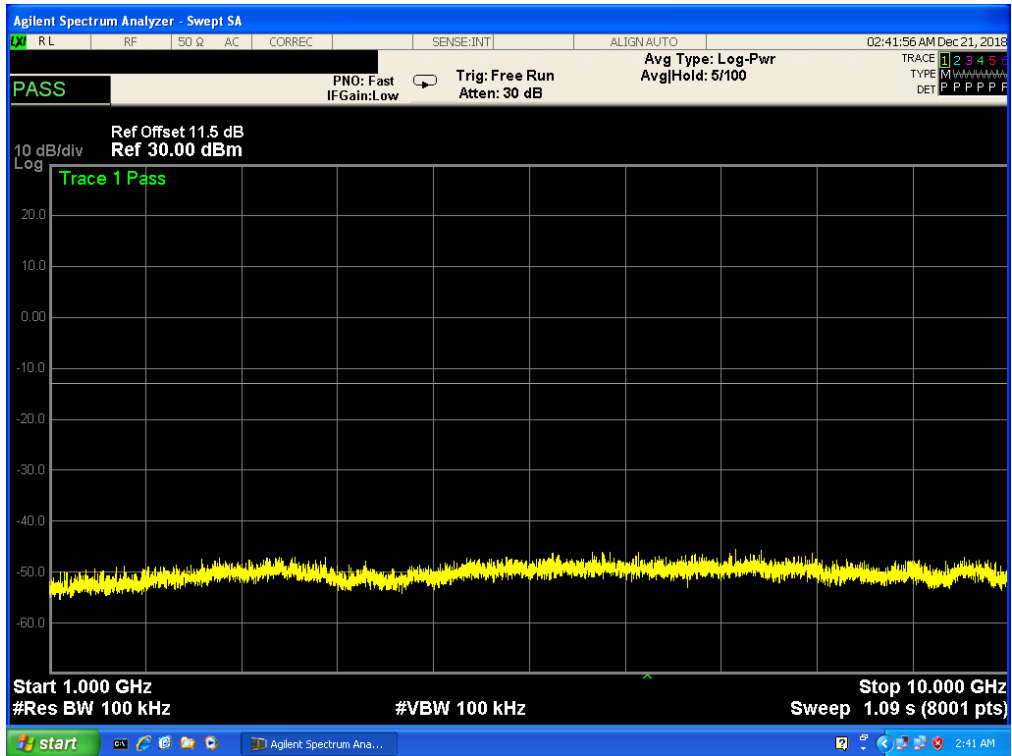

Band 5, UL Channel 20415, UL Frequency 825.5, BW 3.0, NO. RB 15, RB POS. Low, QPSK

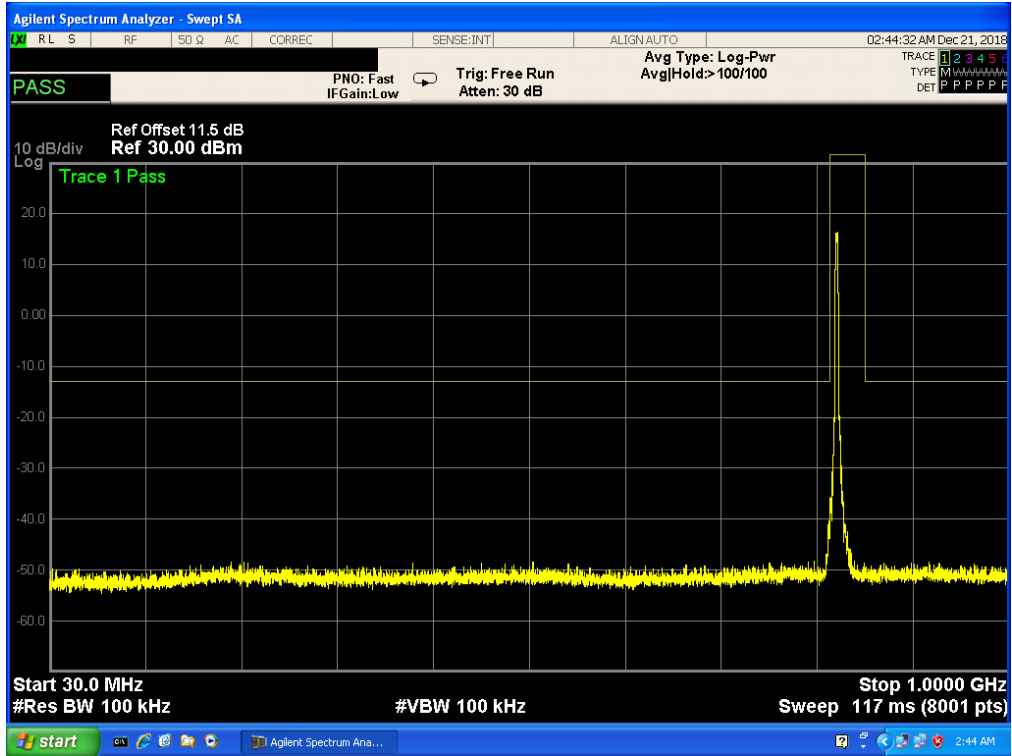

Band 5, UL Channel 20415, UL Frequency 825.5, BW 3.0, NO. RB 15, RB POS. Low, QPSK

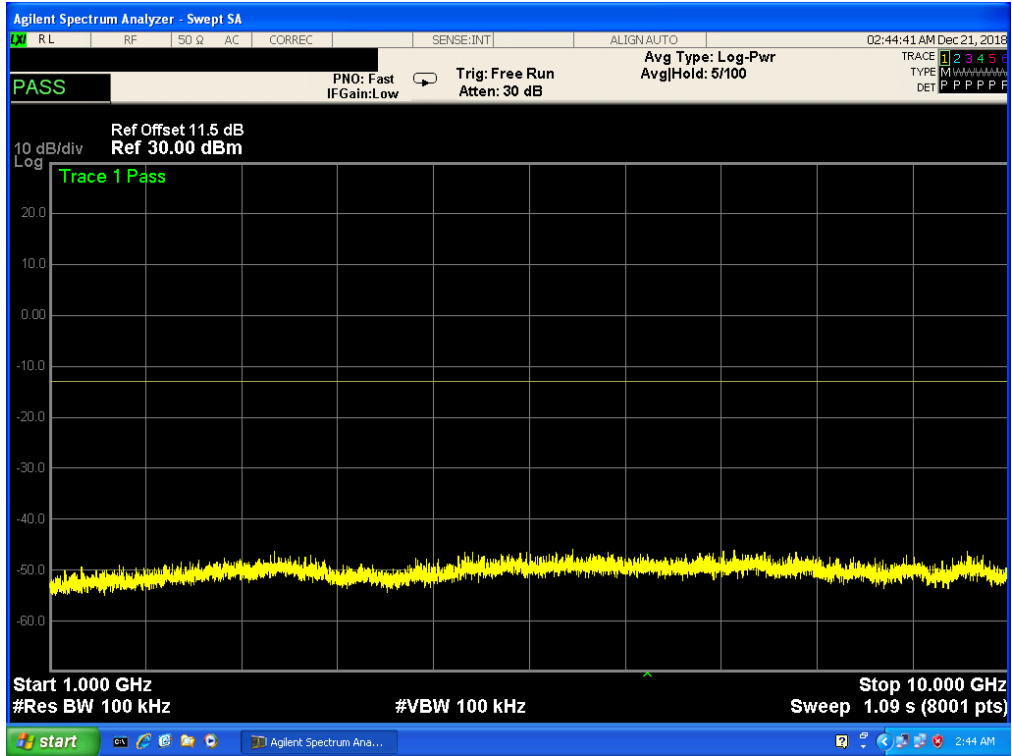

Band 5, UL Channel 20415, UL Frequency 825.5, BW 3.0, NO. RB 15, RB POS. Low, 16-QAM

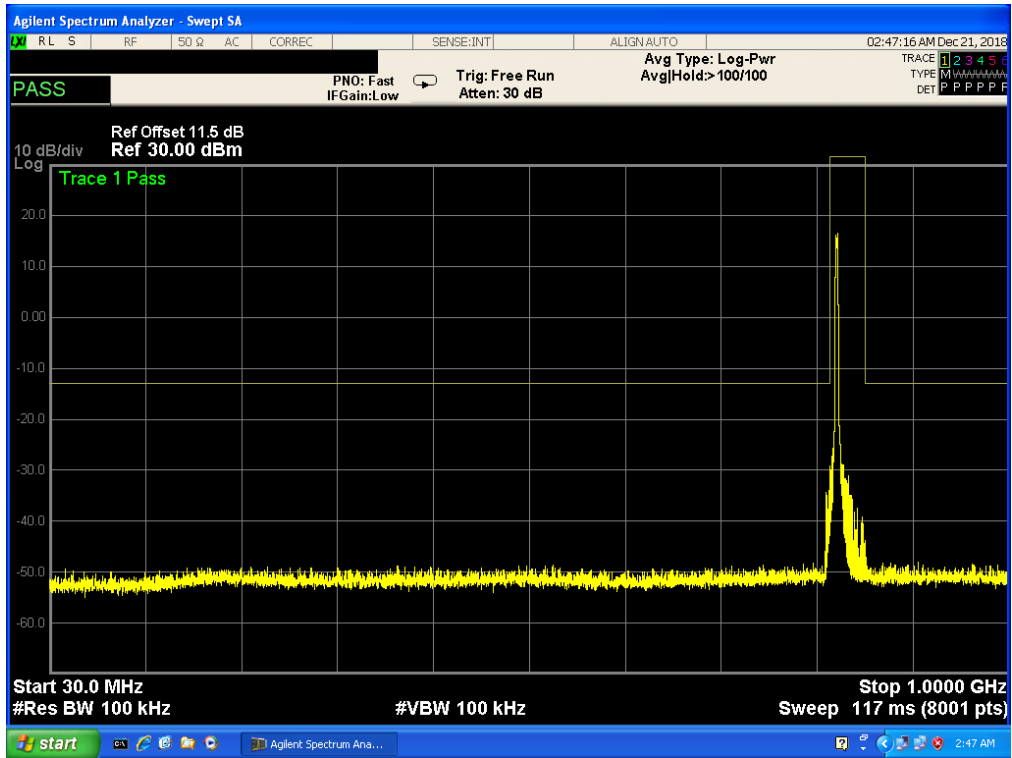

Band 5, UL Channel 20415, UL Frequency 825.5, BW 3.0, NO. RB 15, RB POS. Low, 16-QAM

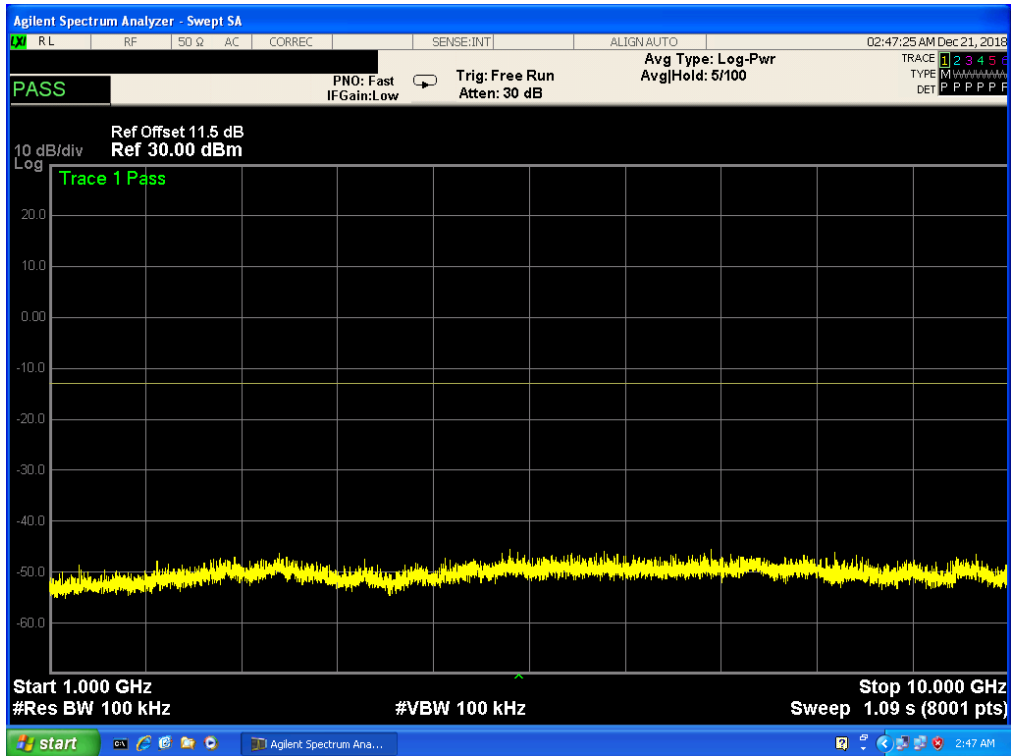

Band 5, UL Channel 20635, UL Frequency 847.5, BW 3.0, NO. RB 15, RB POS. Low, QPSK

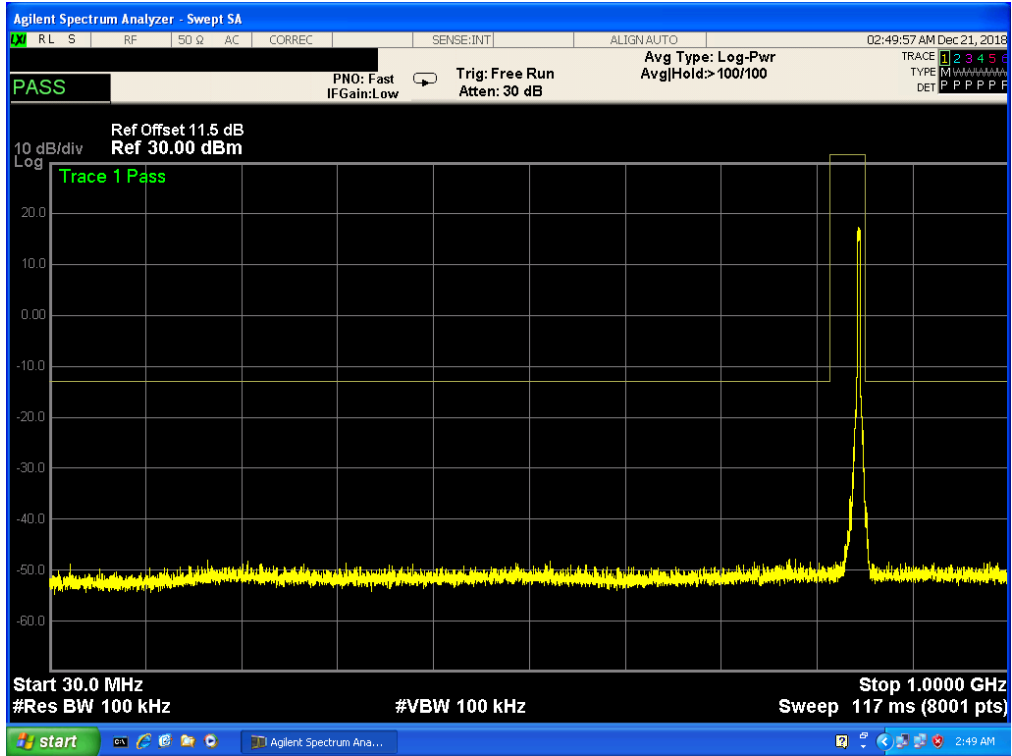

Band 5, UL Channel 20635, UL Frequency 847.5, BW 3.0, NO. RB 15, RB POS. Low, QPSK

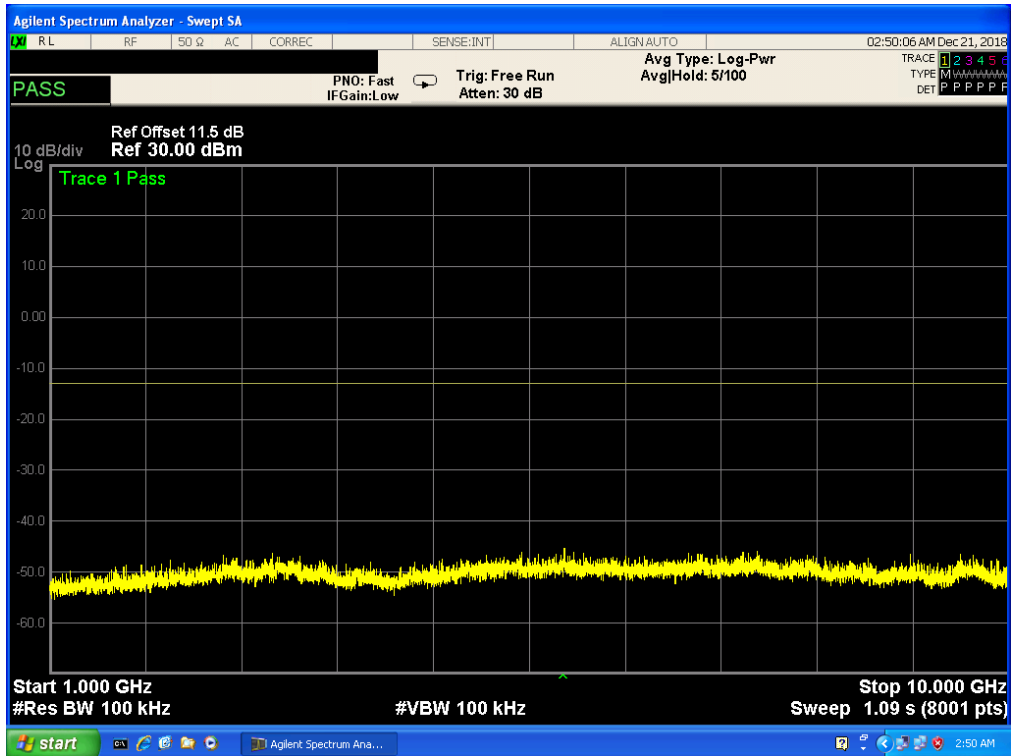



Band 5, UL Channel 20425, UL Frequency 826.5, BW 5.0, NO. RB 25, RB POS. Low, QPSK

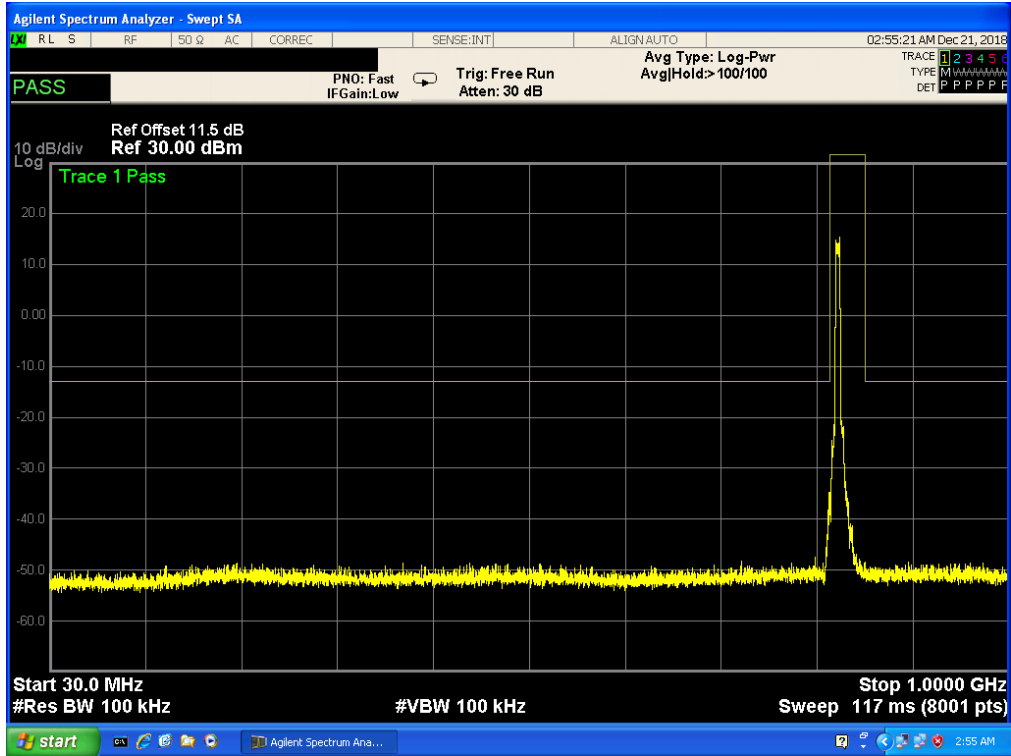

Band 5, UL Channel 20425, UL Frequency 826.5, BW 5.0, NO. RB 25, RB POS. Low, QPSK

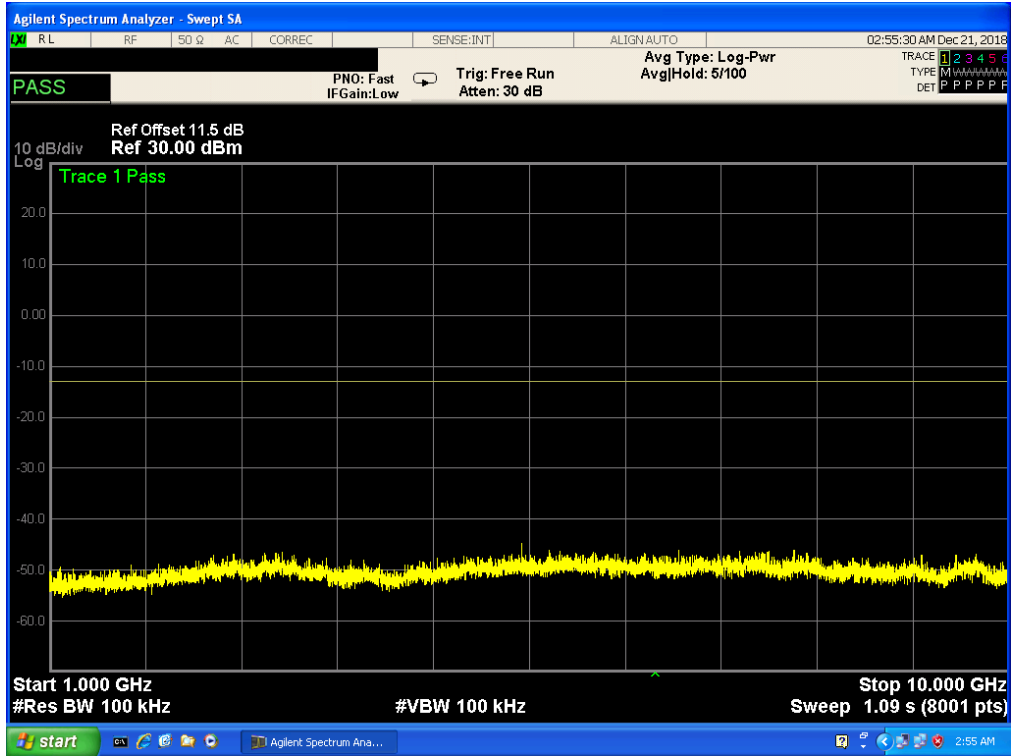

Band 5, UL Channel 20425, UL Frequency 826.5, BW 5.0, NO. RB 25, RB POS. Low, 16-QAM

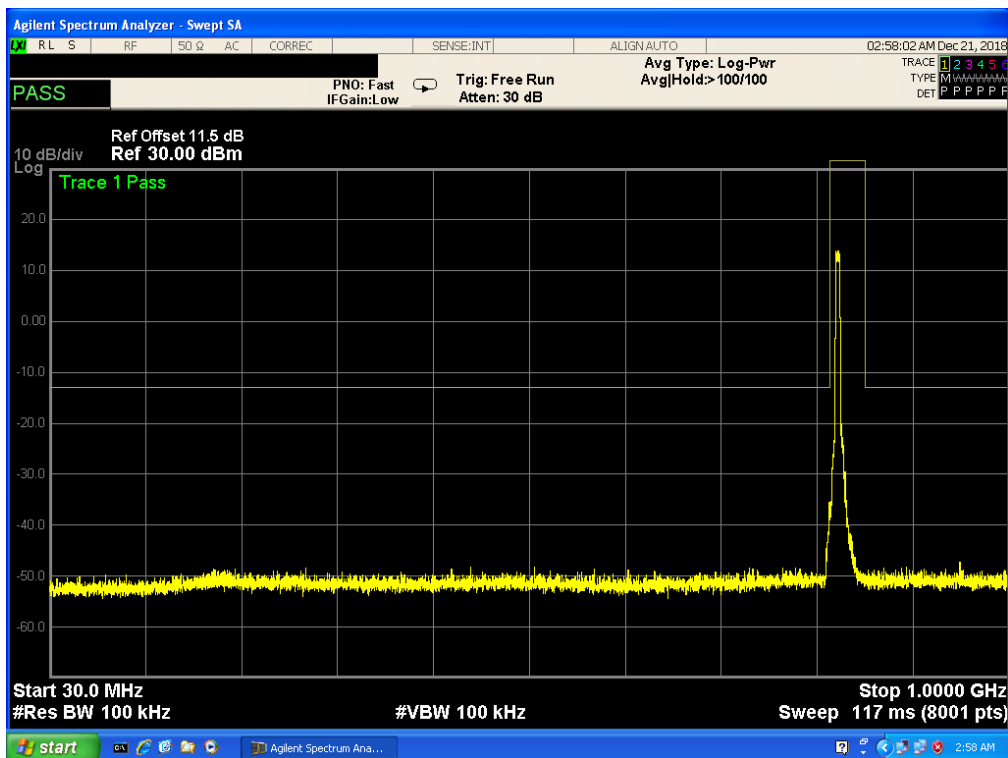

Band 5, UL Channel 20425, UL Frequency 826.5, BW 5.0, NO. RB 25, RB POS. Low, 16-QAM

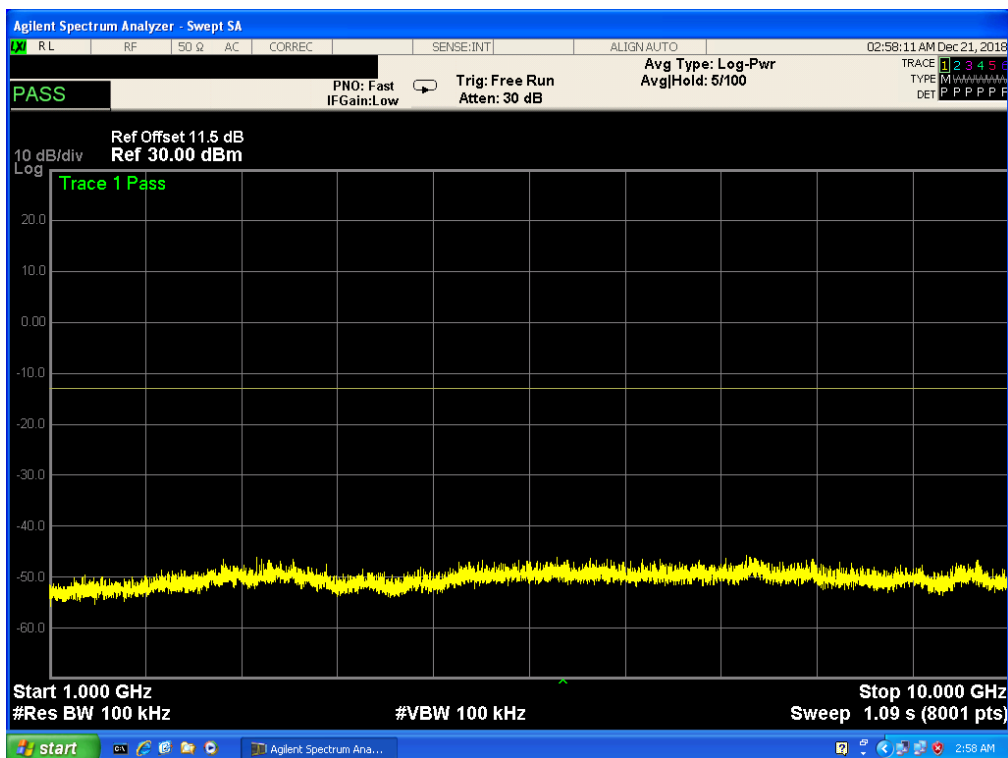

Band 5, UL Channel 20625, UL Frequency 846.5, BW 5.0, NO. RB 25, RB POS. Low, QPSK

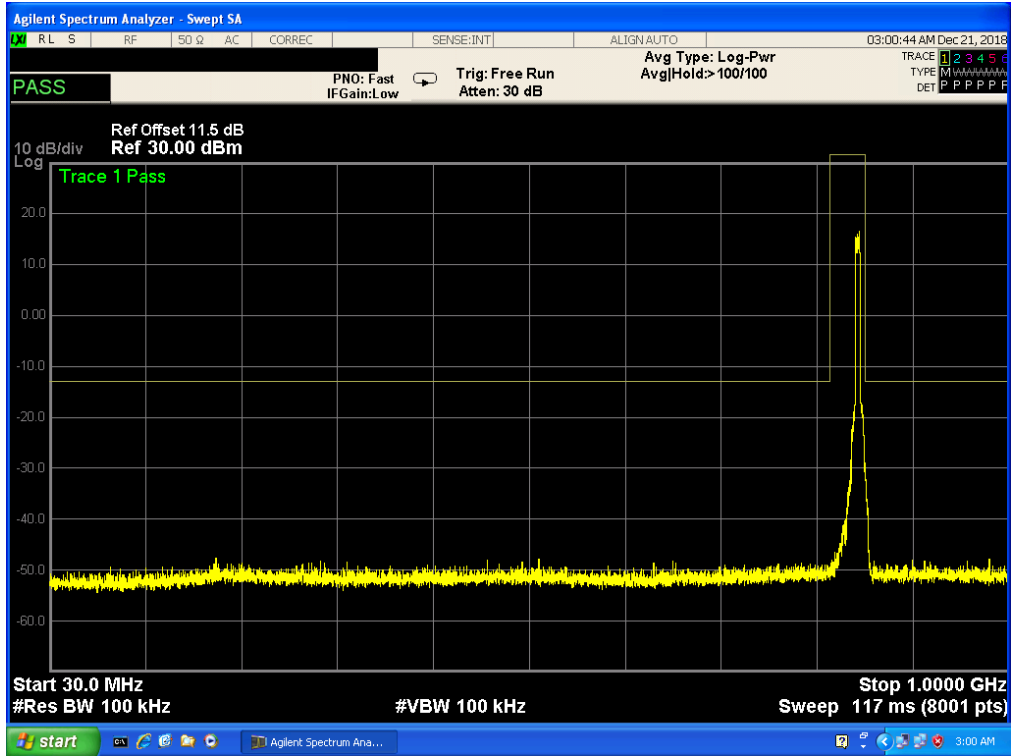

Band 5, UL Channel 20625, UL Frequency 846.5, BW 5.0, NO. RB 25, RB POS. Low, QPSK

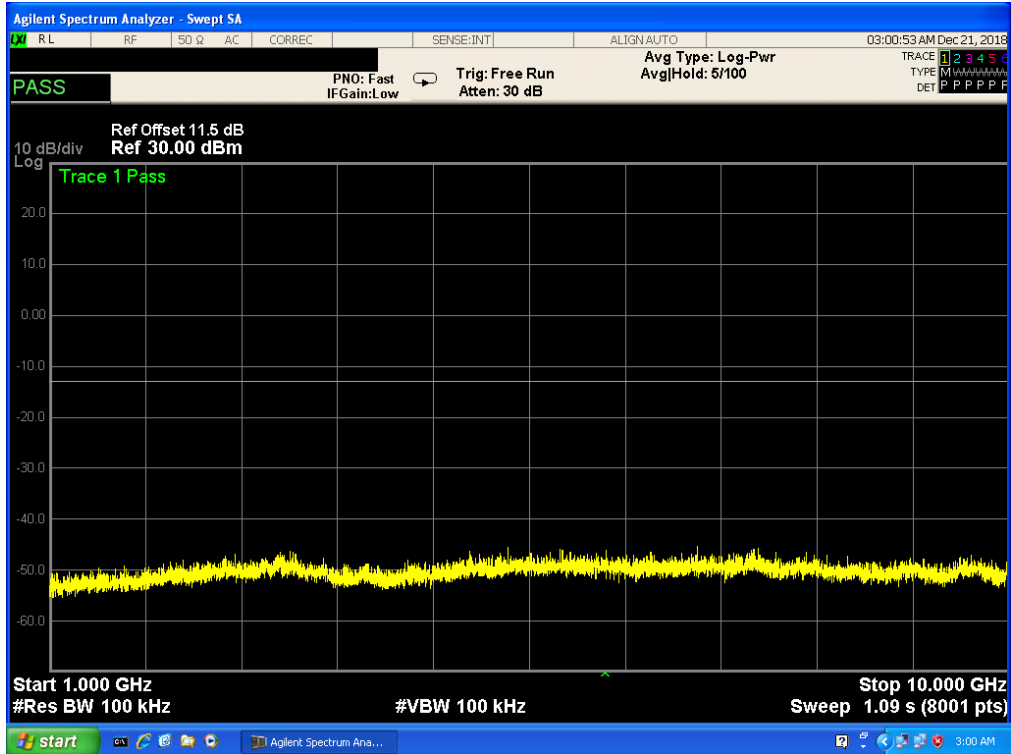

Band 5, UL Channel 20625, UL Frequency 846.5, BW 5.0, NO. RB 25, RB POS. Low, 16-QAM

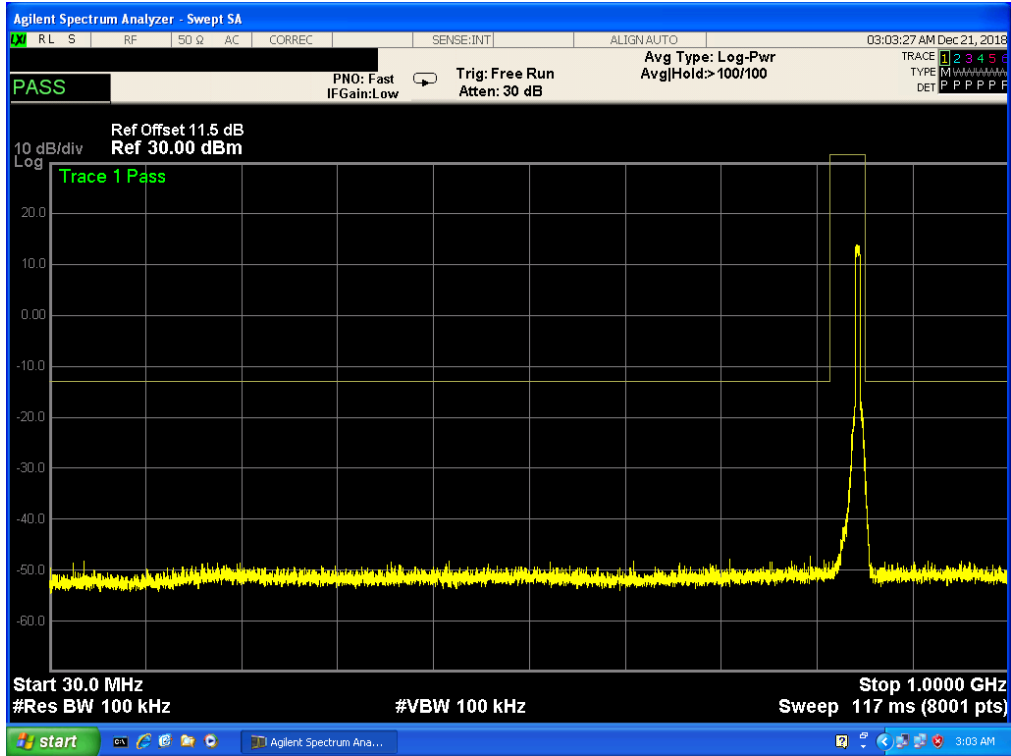

Band 5, UL Channel 20625, UL Frequency 846.5, BW 5.0, NO. RB 25, RB POS. Low, 16-QAM

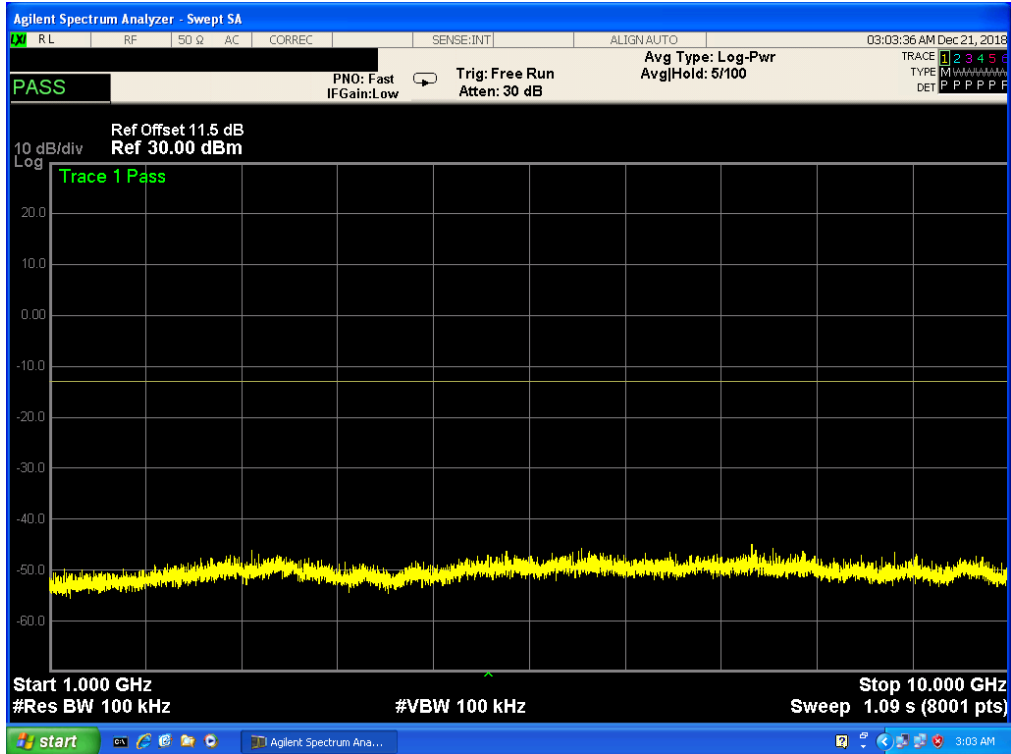



Band 5, UL Channel 20450, UL Frequency 829.0, BW 10.0, NO. RB 50, RB POS. Low, 16-QAM

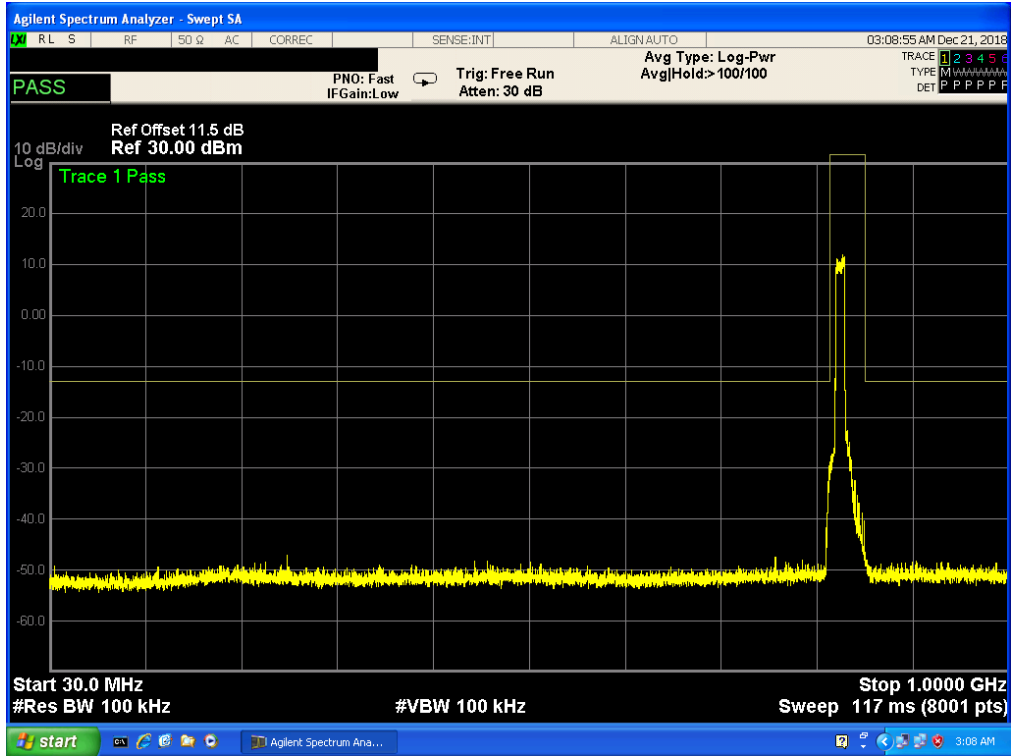

Band 5, UL Channel 20450, UL Frequency 829.0, BW 10.0, NO. RB 50, RB POS. Low, 16-QAM

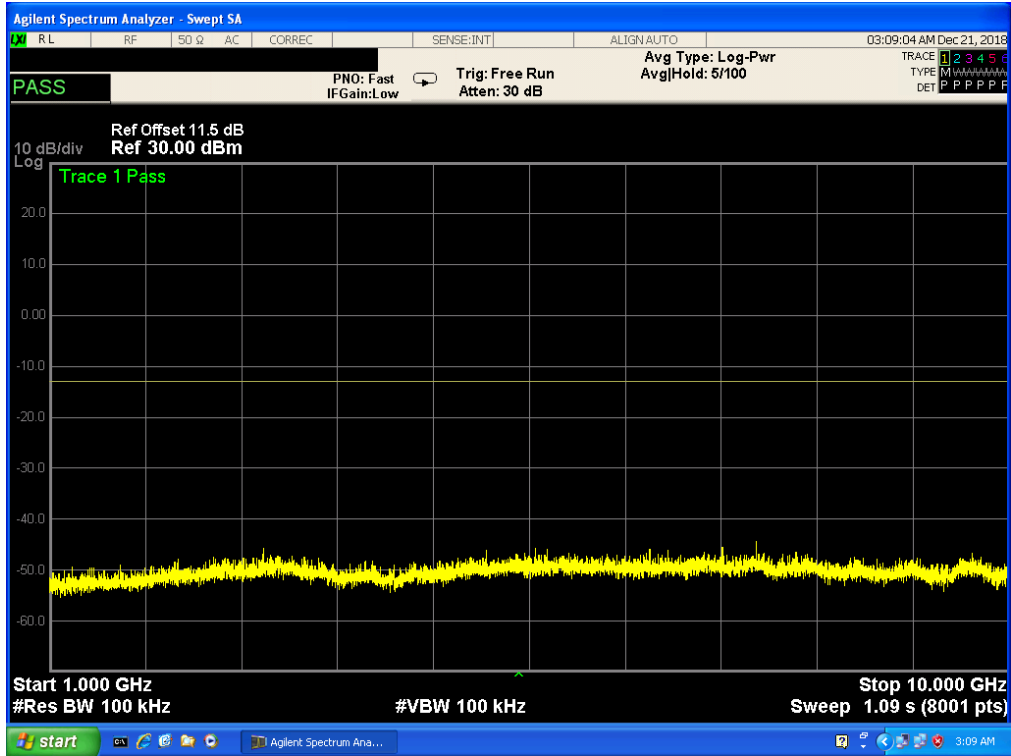

Band 5, UL Channel 20600, UL Frequency 844.0, BW 10.0, NO. RB 50, RB POS. Low, QPSK

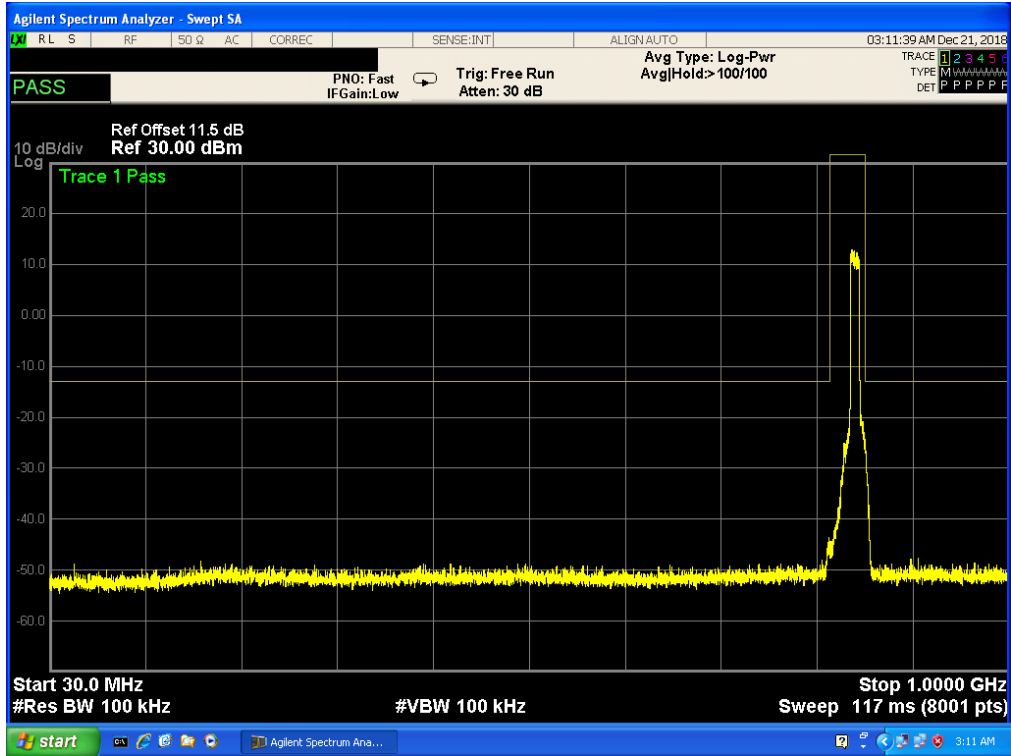

Band 5, UL Channel 20600, UL Frequency 844.0, BW 10.0, NO. RB 50, RB POS. Low, QPSK

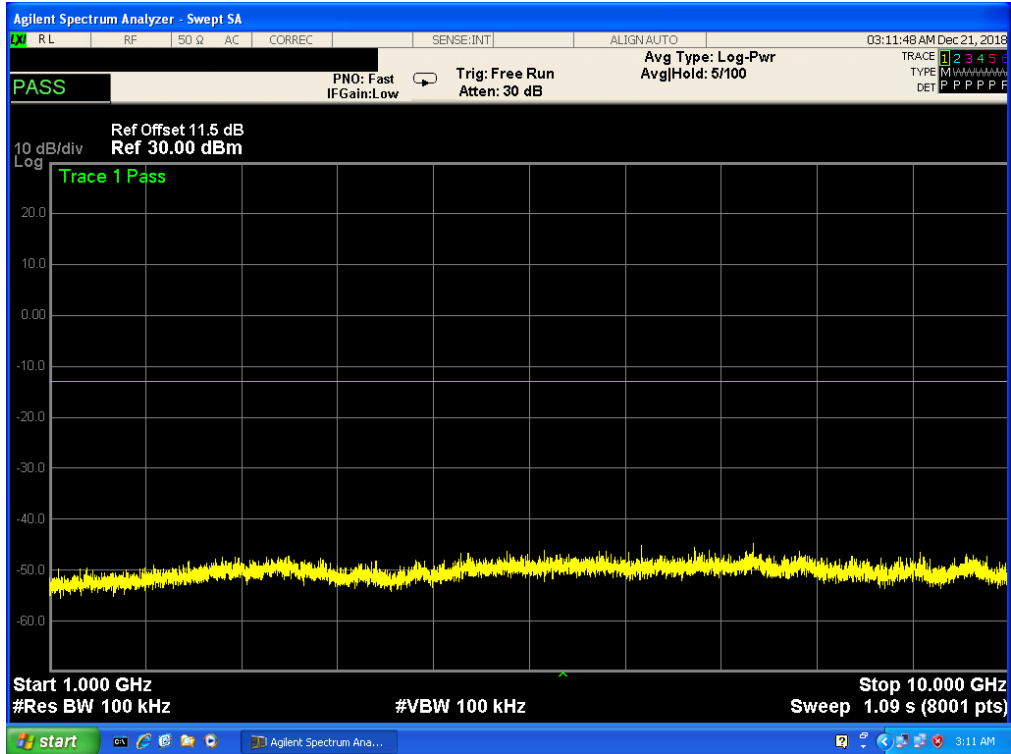

Band 5, UL Channel 20600, UL Frequency 844.0, BW 10.0, NO. RB 50, RB POS. Low, 16-QAM

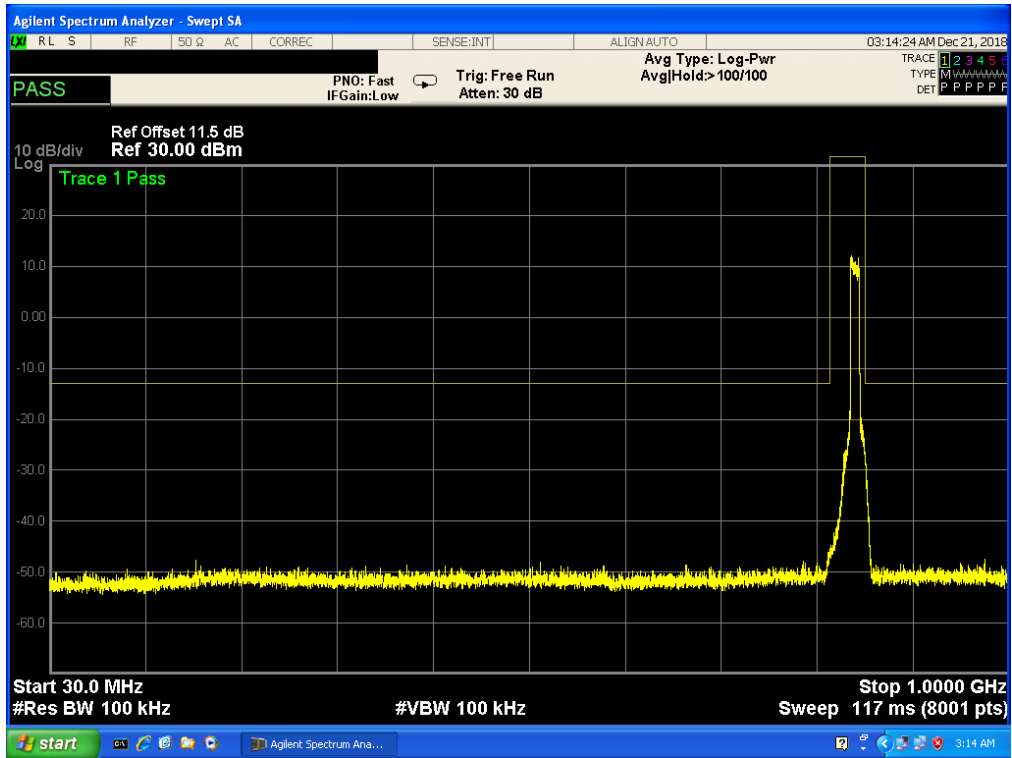

Band 5, UL Channel 20600, UL Frequency 844.0, BW 10.0, NO. RB 50, RB POS. Low, 16-QAM

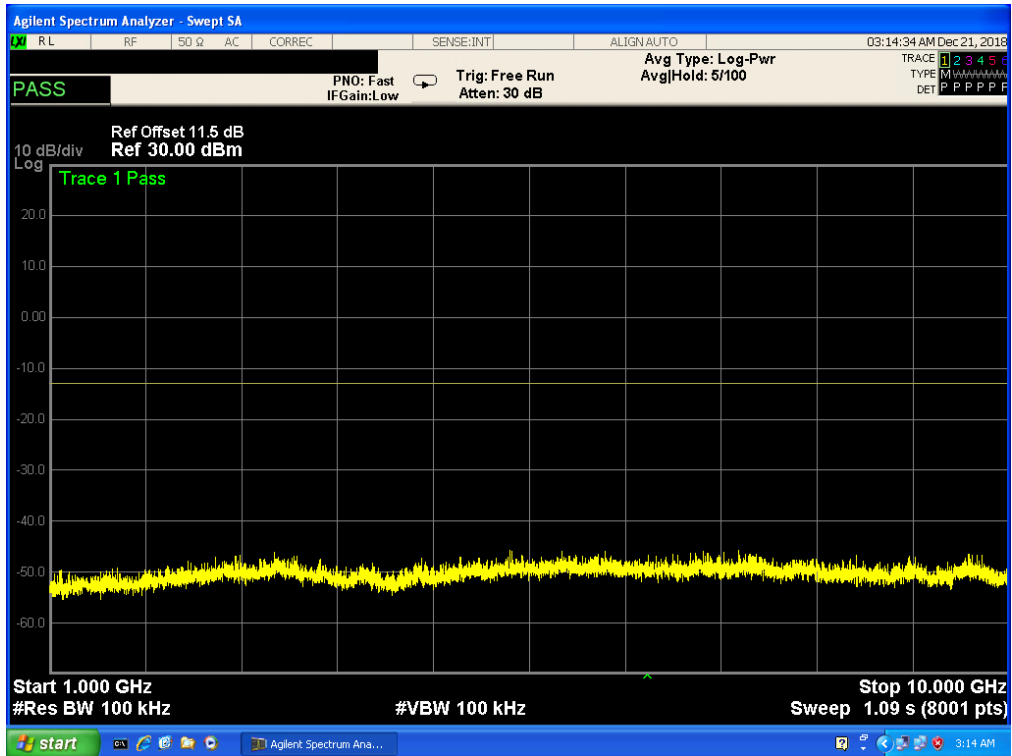

### 7.3 LTE BAND 7

Band 7, UL Channel 20775, UL Frequency 2502.5, BW 5.0, NO. RB 25, RB POS. Low, QPSK

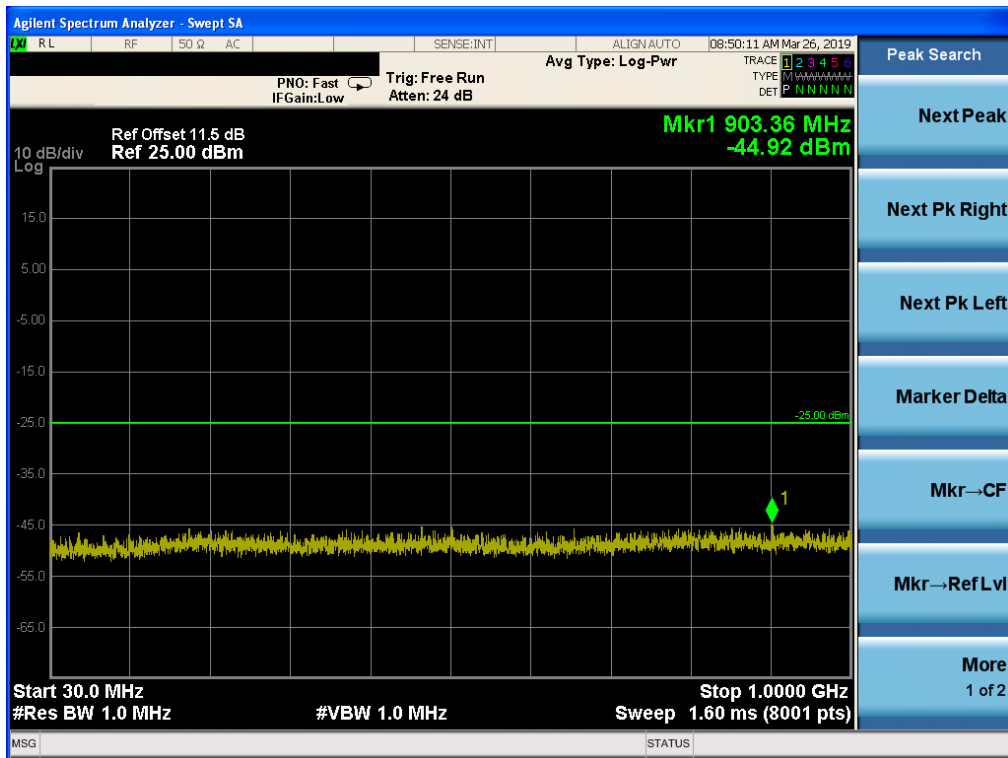

Band 7, UL Channel 20775, UL Frequency 2502.5, BW 5.0, NO. RB 25, RB POS. Low, QPSK

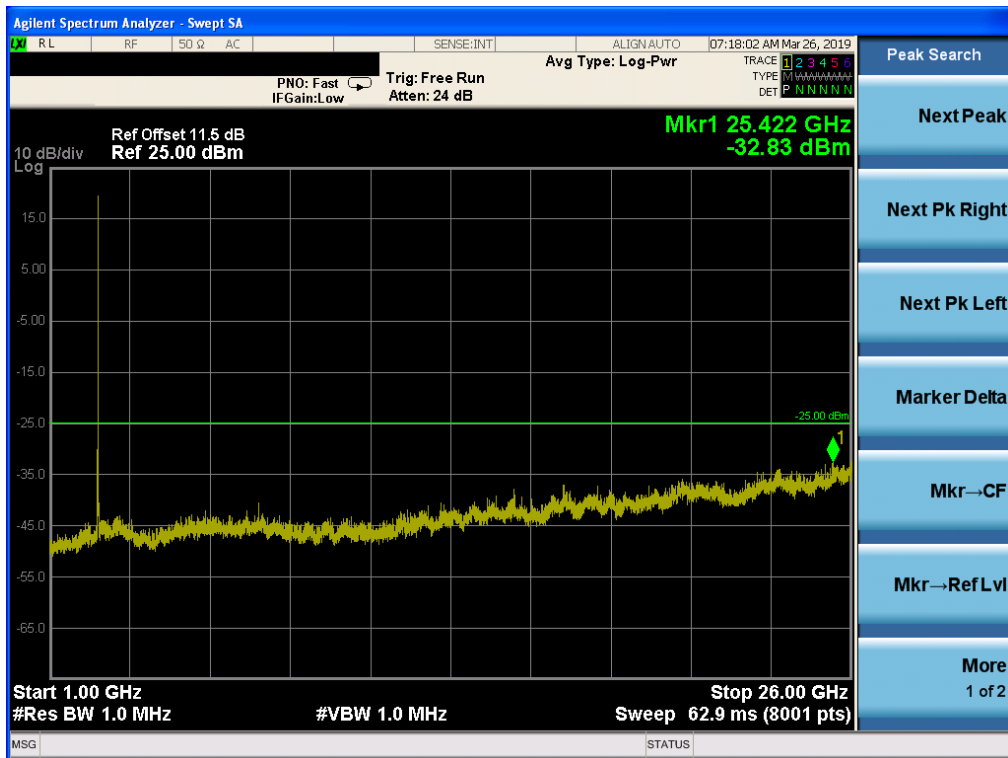

Band 7, UL Channel 20775, UL Frequency 2502.5, BW 5.0, NO. RB 25, RB POS. Low, 16-QAM

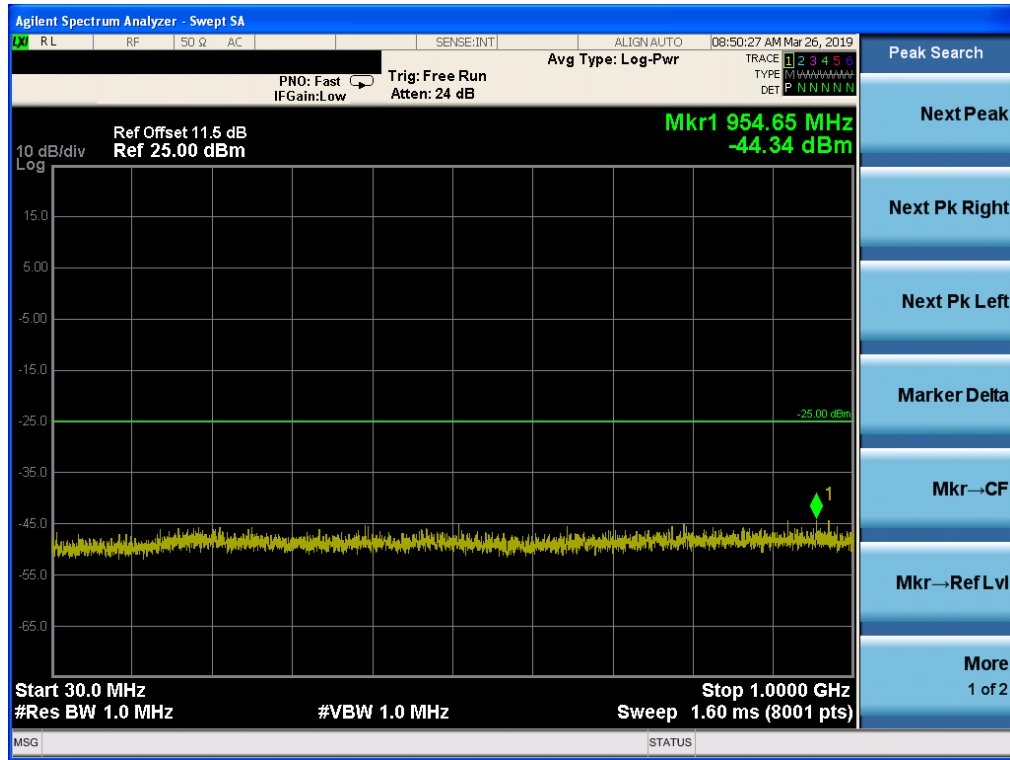

Band 7, UL Channel 20775, UL Frequency 2502.5, BW 5.0, NO. RB 25, RB POS. Low, 16-QAM

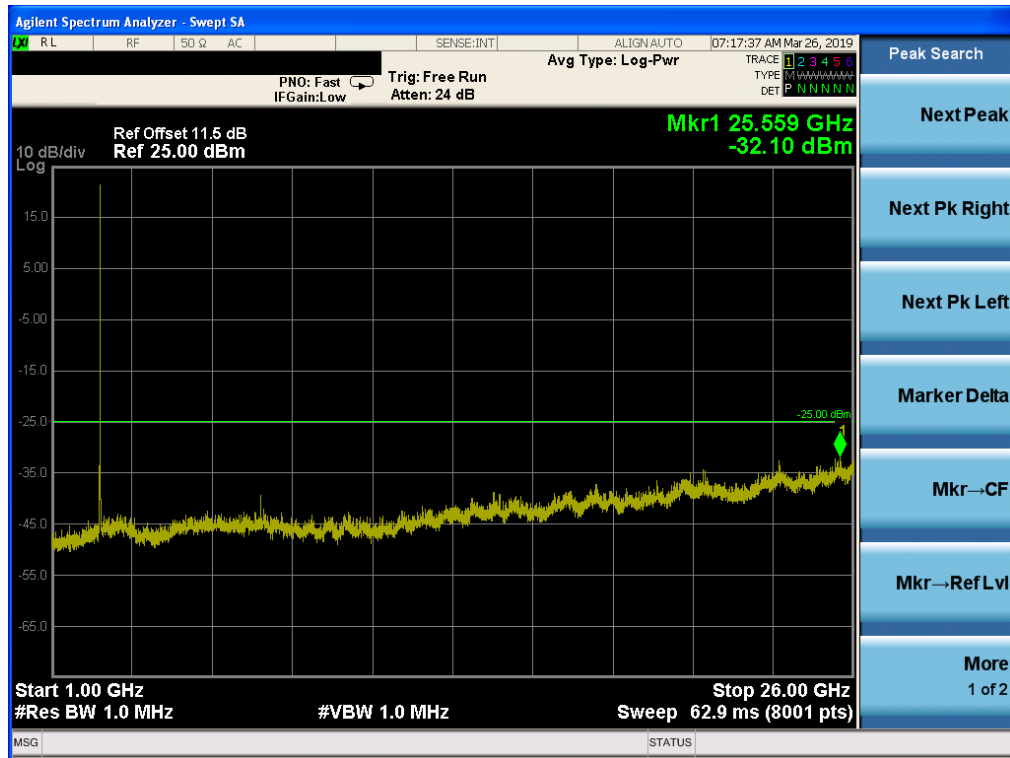

Band 7, UL Channel 21425, UL Frequency 2567.5, BW 5.0, NO. RB 25, RB POS. Low, QPSK

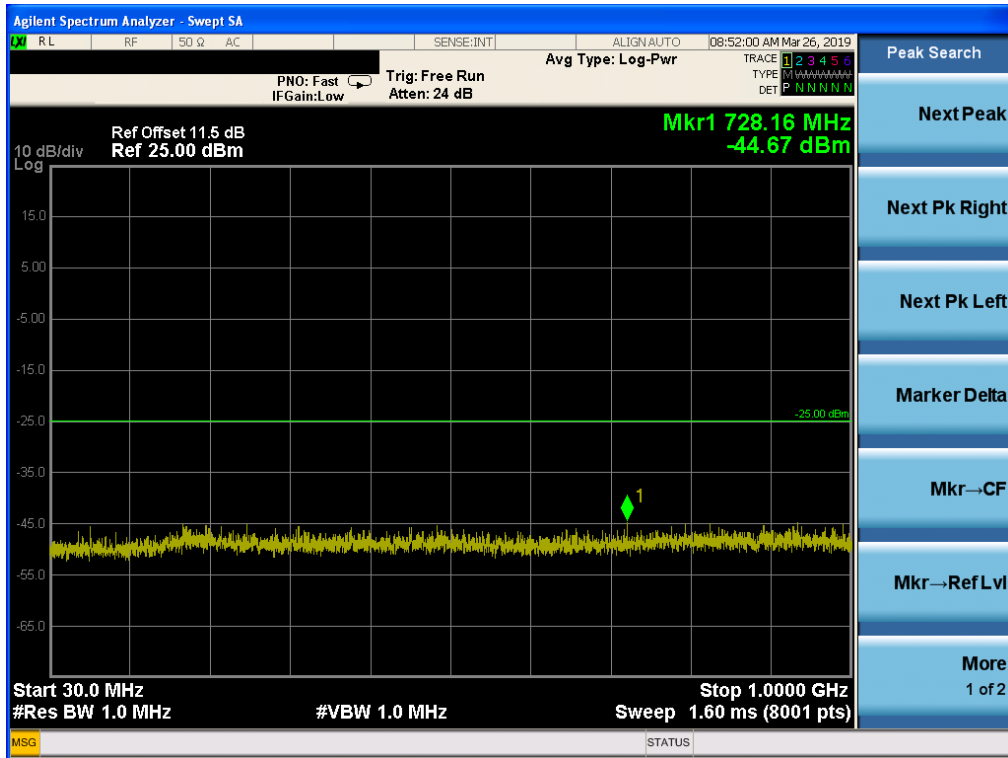

Band 7, UL Channel 21425, UL Frequency 2567.5, BW 5.0, NO. RB 25, RB POS. Low, QPSK

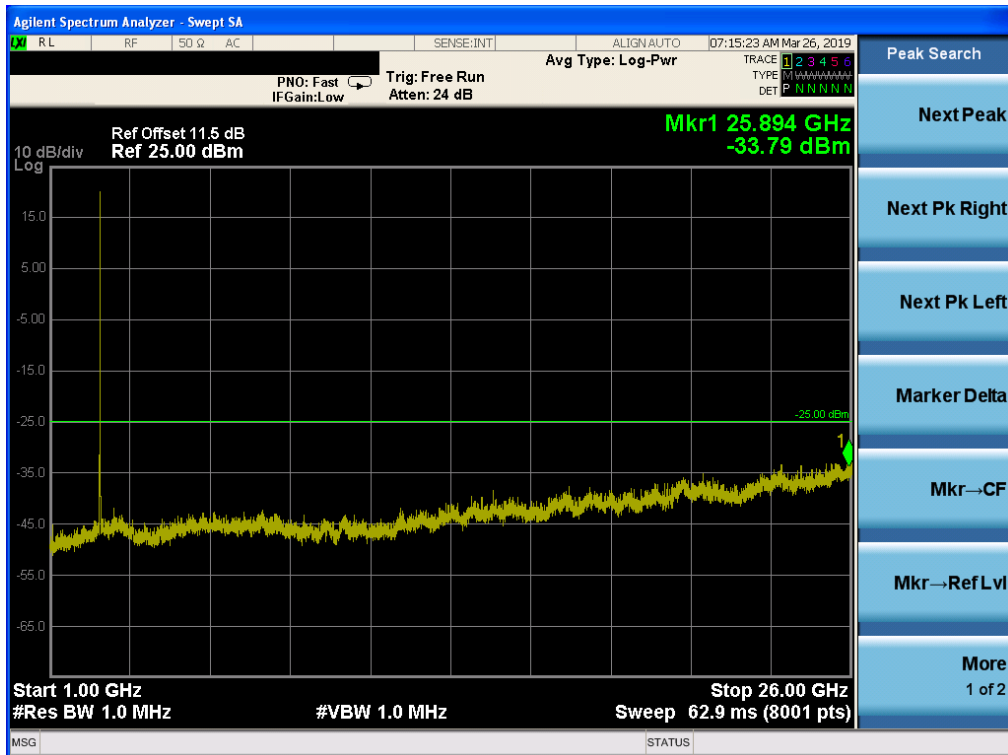

Band 7, UL Channel 21425, UL Frequency 2567.5, BW 5.0, NO. RB 25, RB POS. Low, 16-QAM

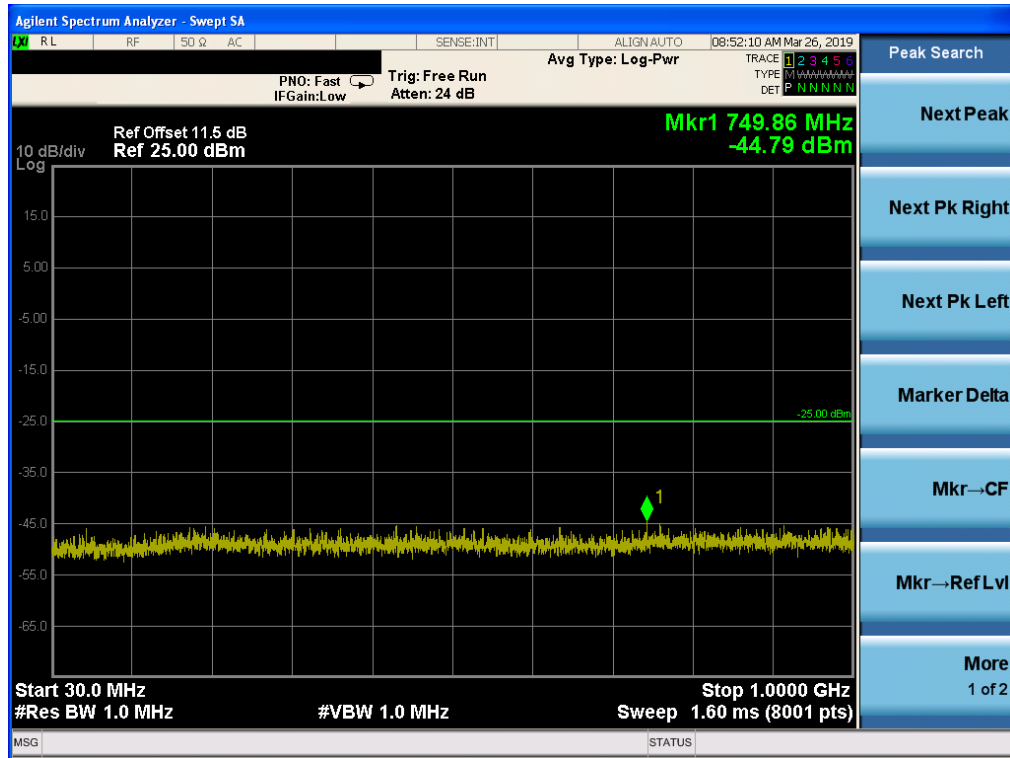

Band 7, UL Channel 21425, UL Frequency 2567.5, BW 5.0, NO. RB 25, RB POS. Low, 16-QAM

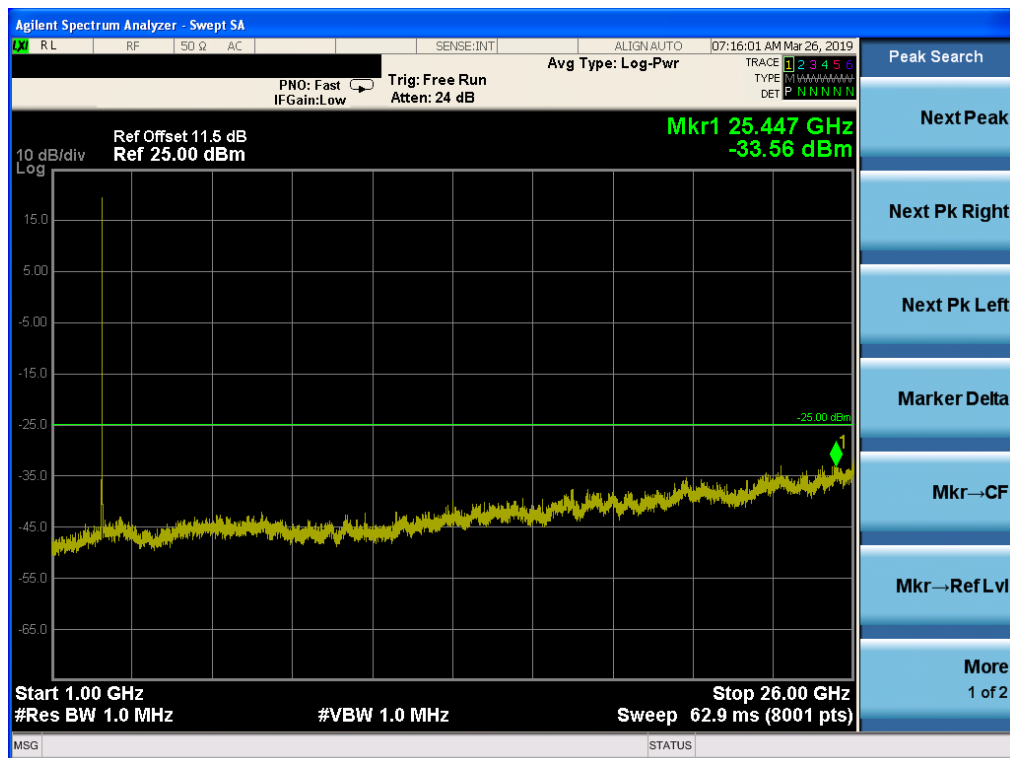

Band 7, UL Channel 20800, UL Frequency 2505.0, BW 10.0, NO. RB 50, RB POS. Low, QPSK

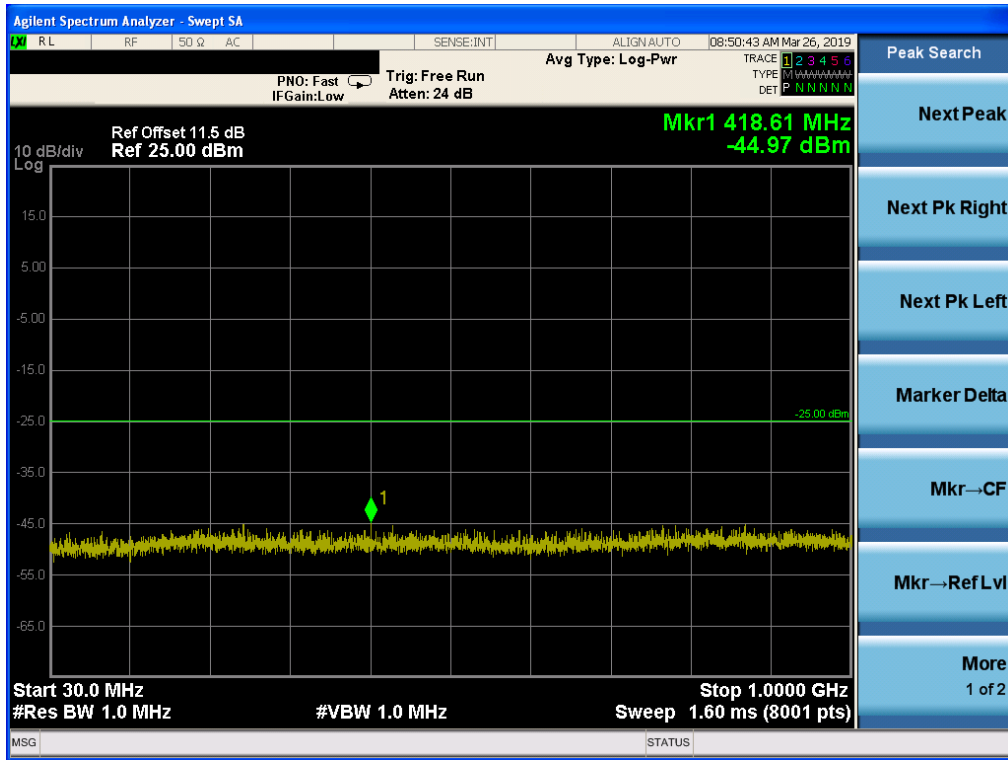

Band 7, UL Channel 20800, UL Frequency 2505.0, BW 10.0, NO. RB 50, RB POS. Low, QPSK

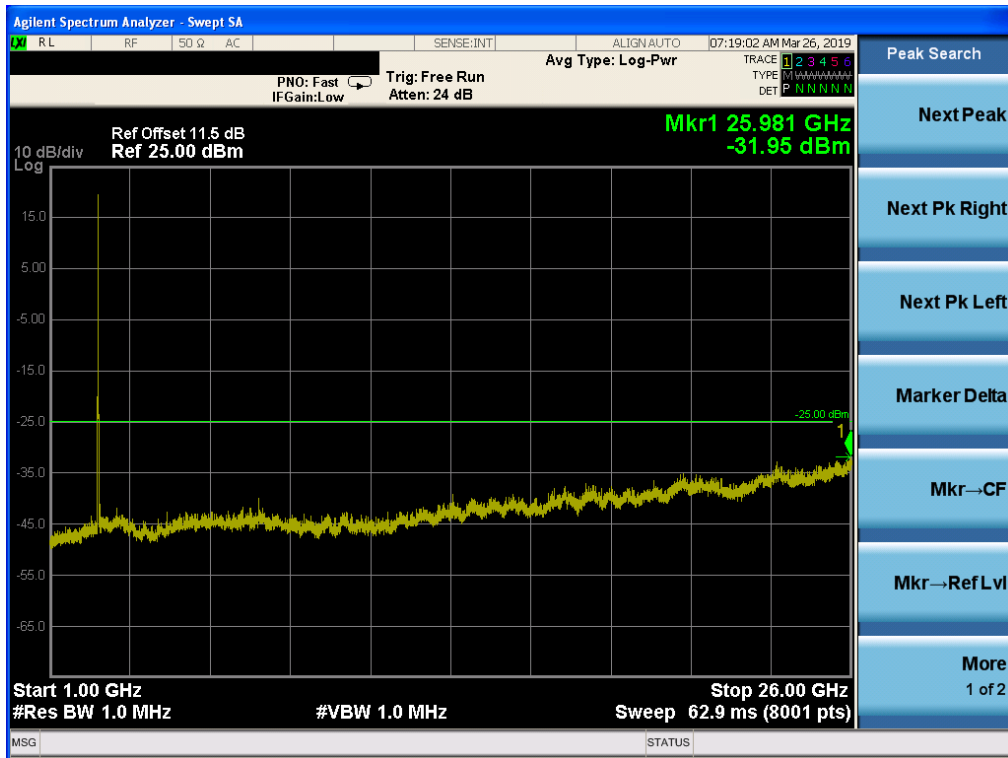

Band 7, UL Channel 20800, UL Frequency 2505.0, BW 10.0, NO. RB 50, RB POS. Low, 16-QAM

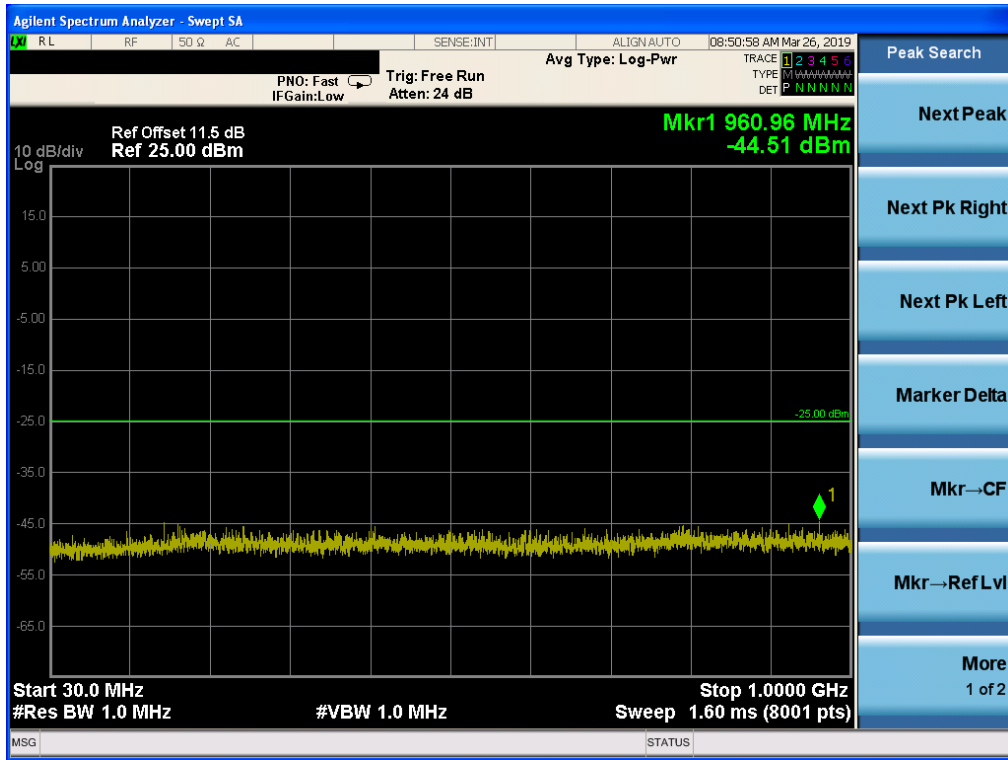

Band 7, UL Channel 20800, UL Frequency 2505.0, BW 10.0, NO. RB 50, RB POS. Low, 16-QAM

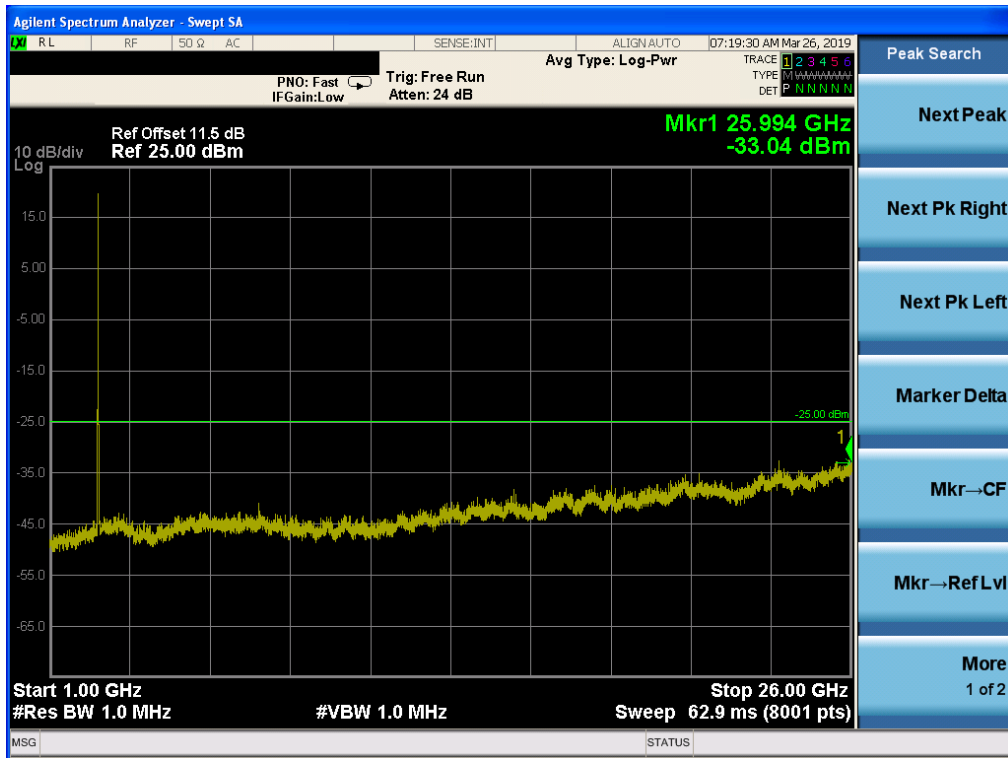

Band 7, UL Channel 21400, UL Frequency 2565.0, BW 10.0, NO. RB 50, RB POS. Low, QPSK

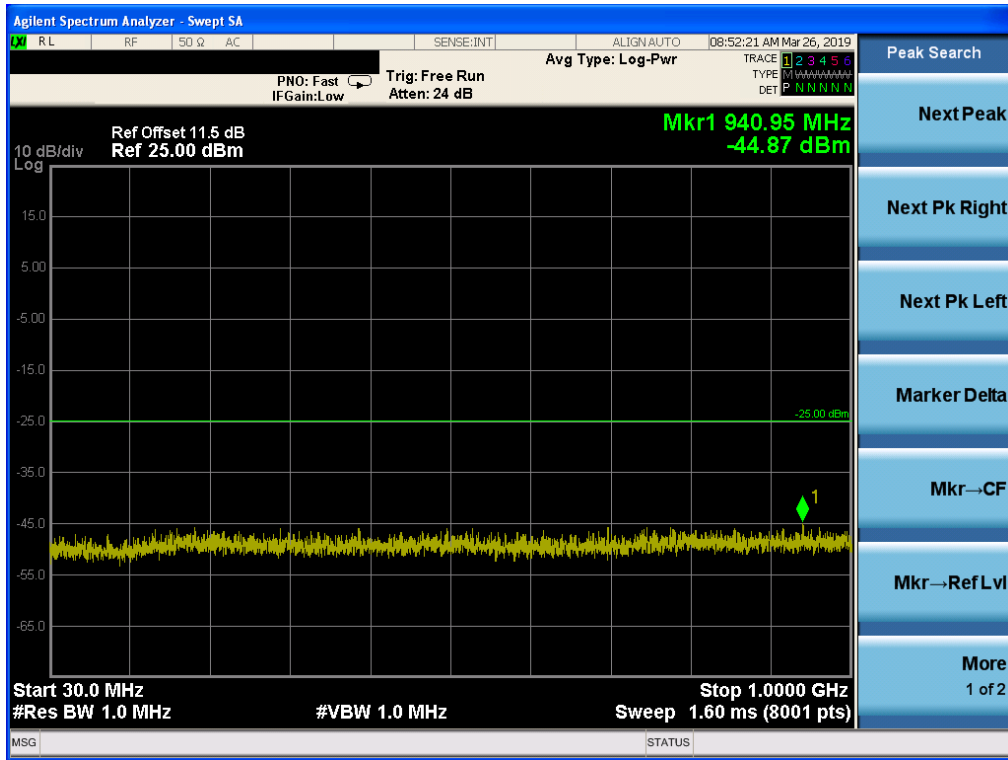

Band 7, UL Channel 21400, UL Frequency 2565.0, BW 10.0, NO. RB 50, RB POS. Low, QPSK

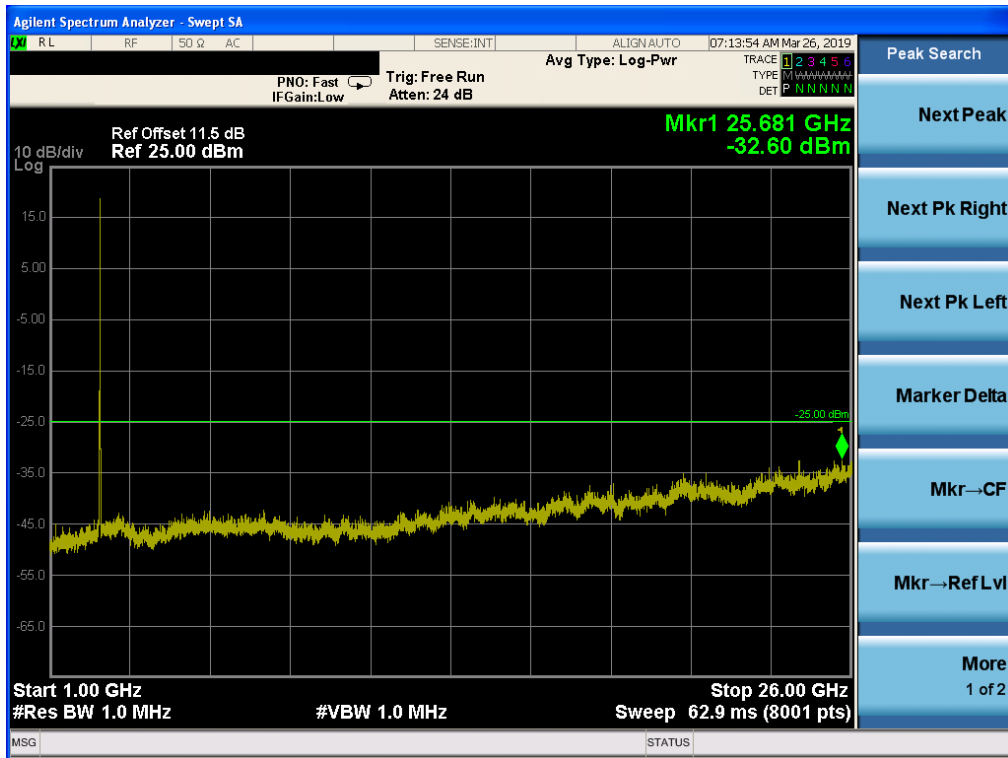

Band 7, UL Channel 21400, UL Frequency 2565.0, BW 10.0, NO. RB 50, RB POS. Low, 16-QAM

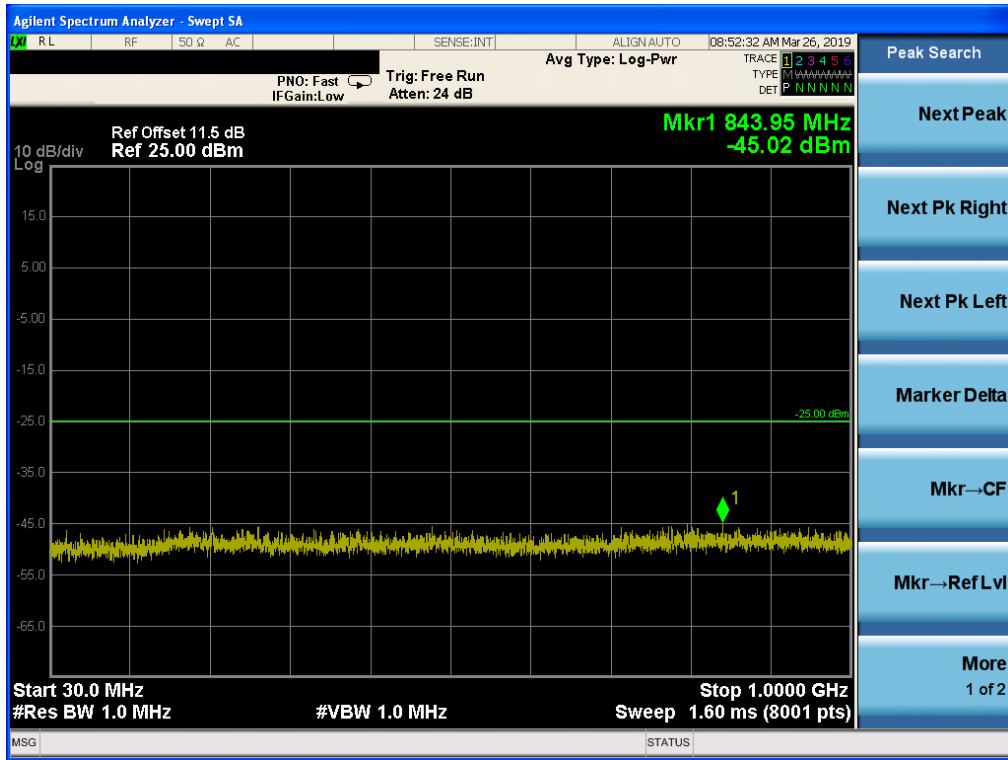

Band 7, UL Channel 21400, UL Frequency 2565.0, BW 10.0, NO. RB 50, RB POS. Low, 16-QAM

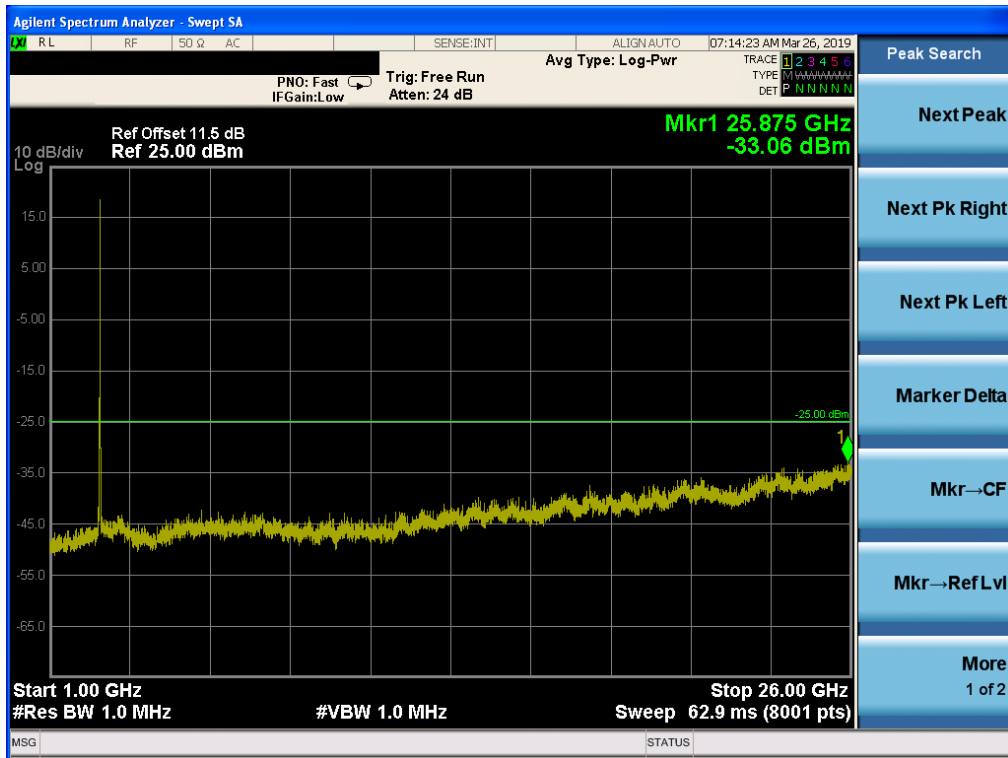

Band 7, UL Channel 20825, UL Frequency 2507.5, BW 15.0, NO. RB 75, RB POS. Low, QPSK

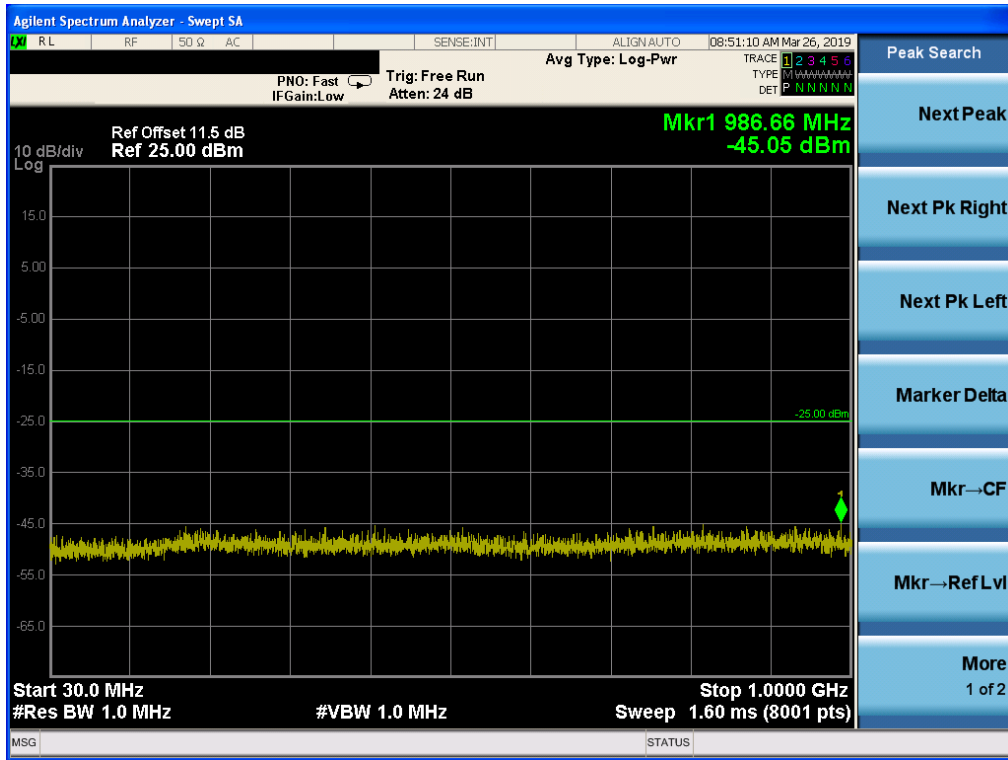

Band 7, UL Channel 20825, UL Frequency 2507.5, BW 15.0, NO. RB 75, RB POS. Low, QPSK

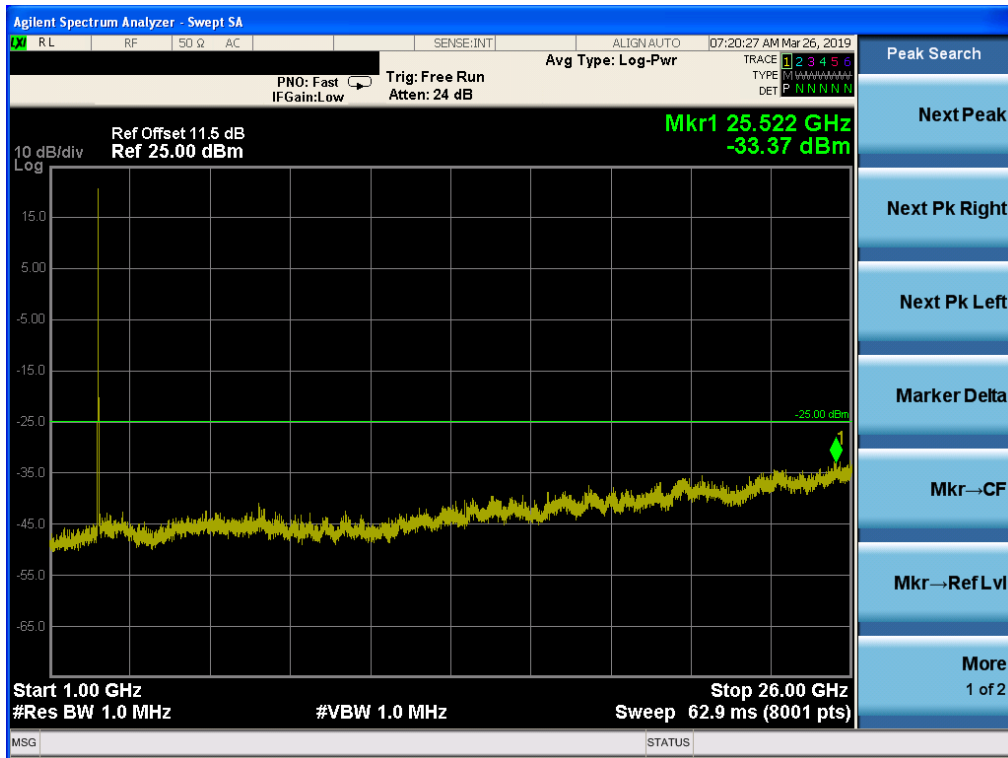

Band 7, UL Channel 20825, UL Frequency 2507.5, BW 15.0, NO. RB 75, RB POS. Low, 16-QAM

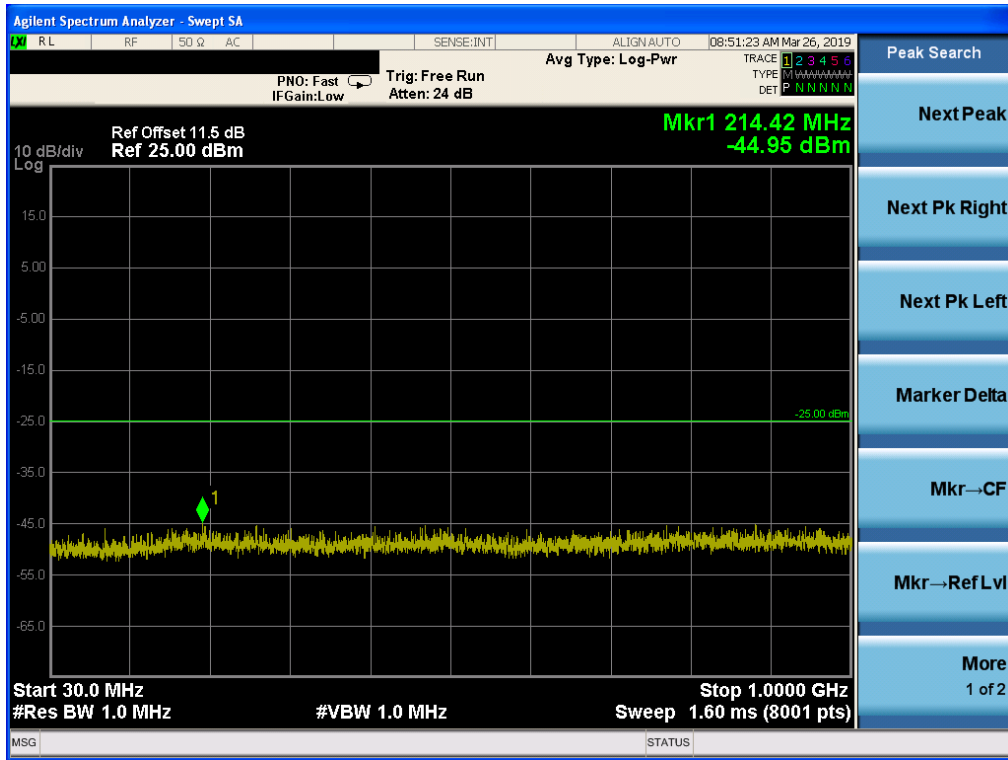

Band 7, UL Channel 20825, UL Frequency 2507.5, BW 15.0, NO. RB 75, RB POS. Low, 16-QAM

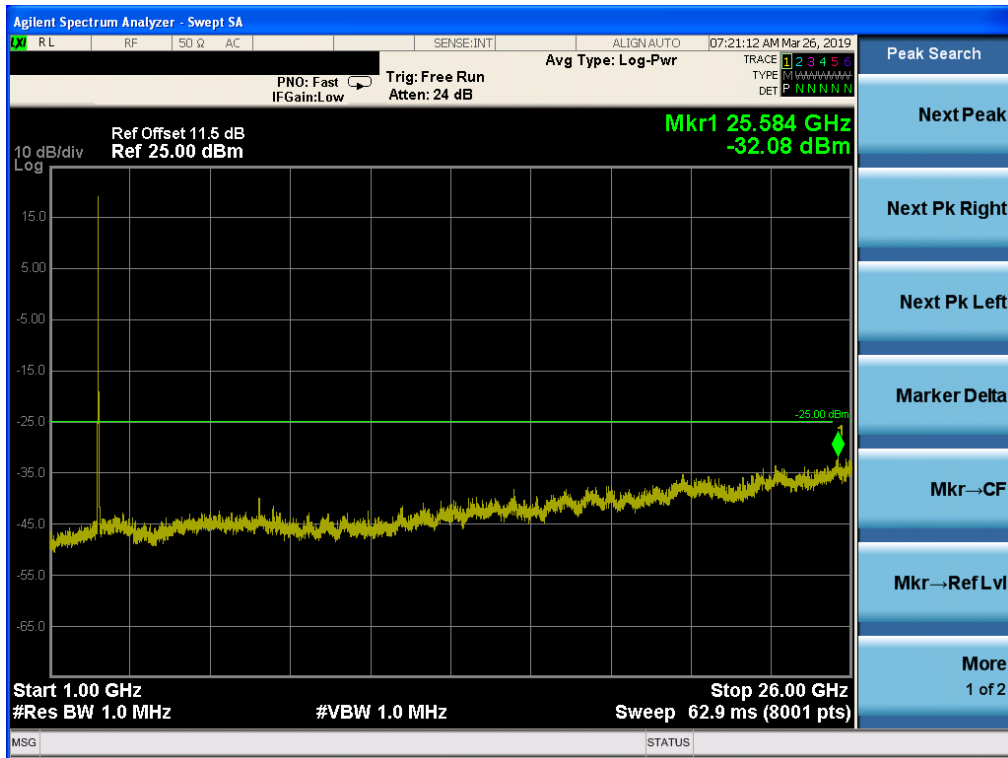

Band 7, UL Channel 21375, UL Frequency 2562.5, BW 15.0, NO. RB 75, RB POS. Low, QPSK

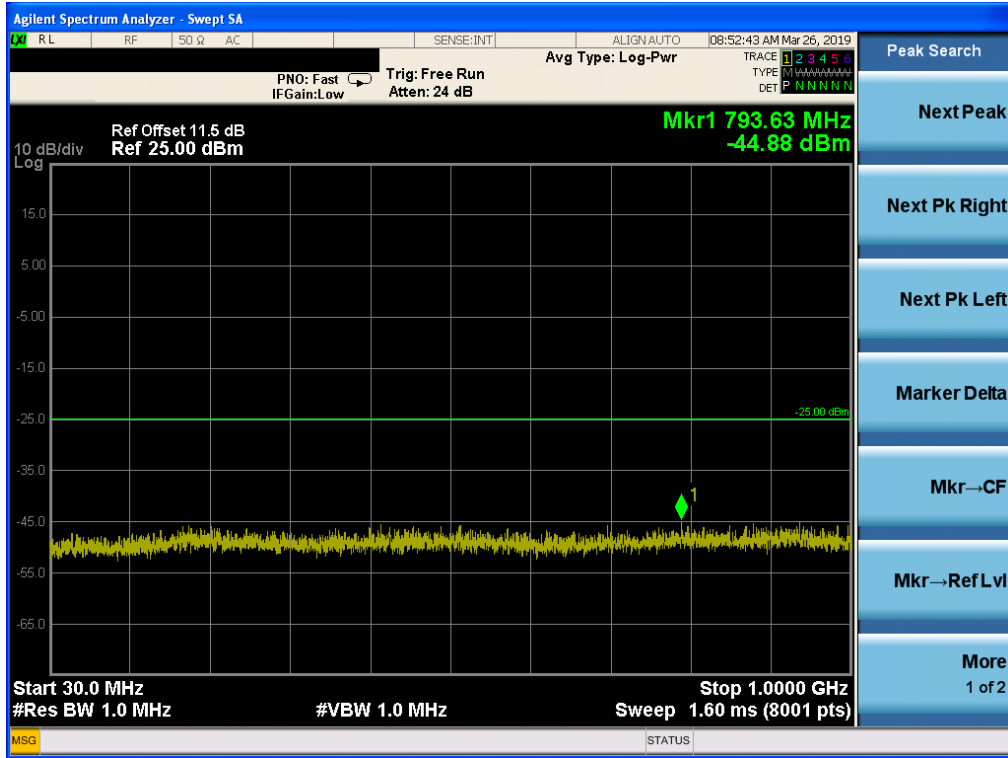

Band 7, UL Channel 21375, UL Frequency 2562.5, BW 15.0, NO. RB 75, RB POS. Low, QPSK

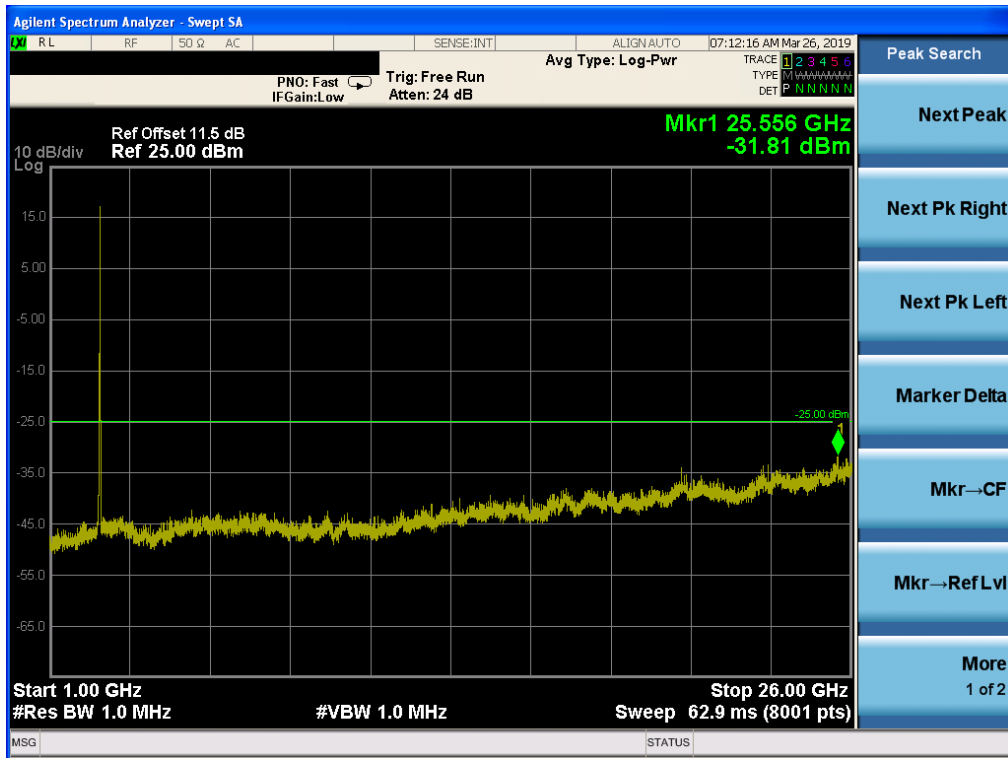

Band 7, UL Channel 21375, UL Frequency 2562.5, BW 15.0, NO. RB 75, RB POS. Low, 16-QAM

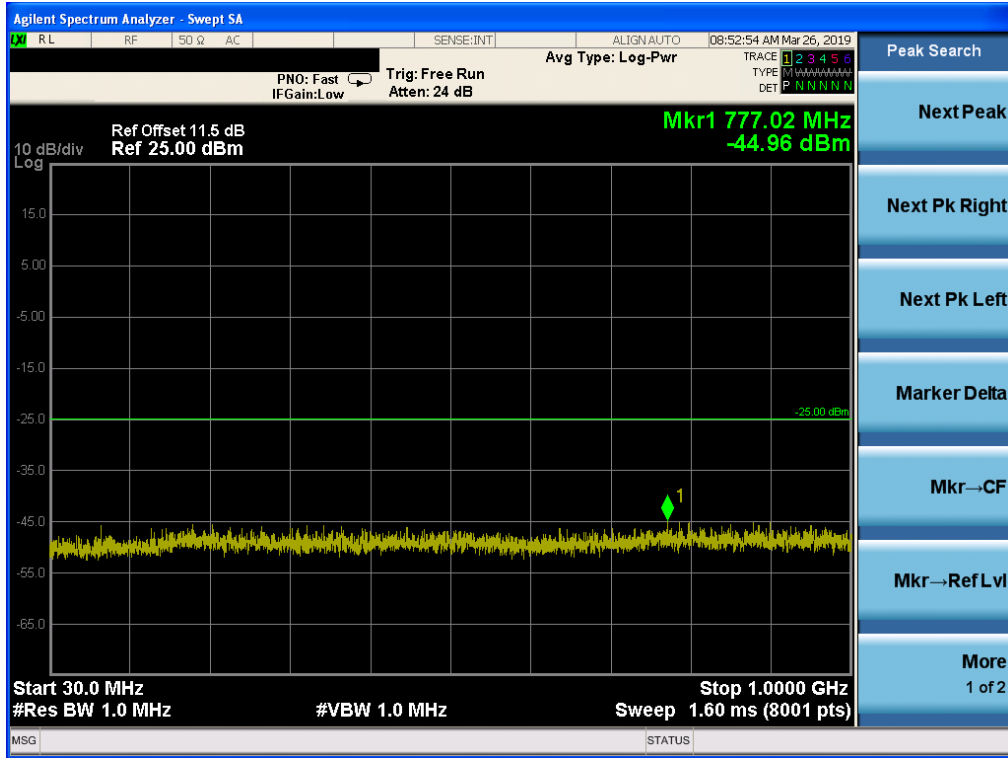

Band 7, UL Channel 21375, UL Frequency 2562.5, BW 15.0, NO. RB 75, RB POS. Low, 16-QAM

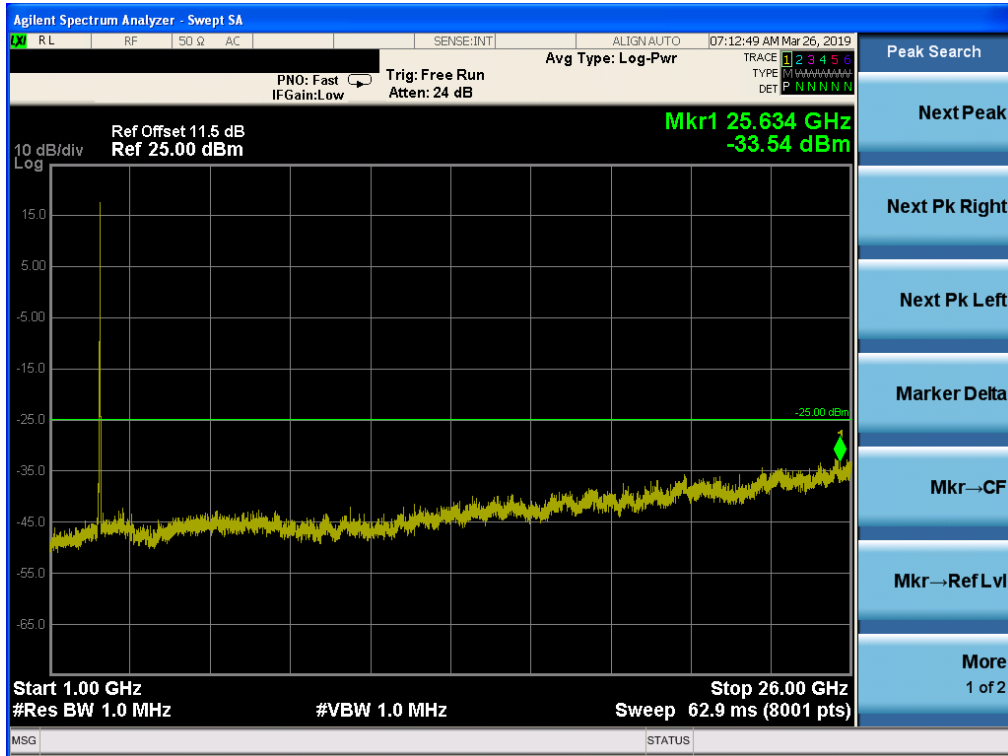

Band 7, UL Channel 20850, UL Frequency 2510.0, BW 20.0, NO. RB 100, RB POS. Low, QPSK

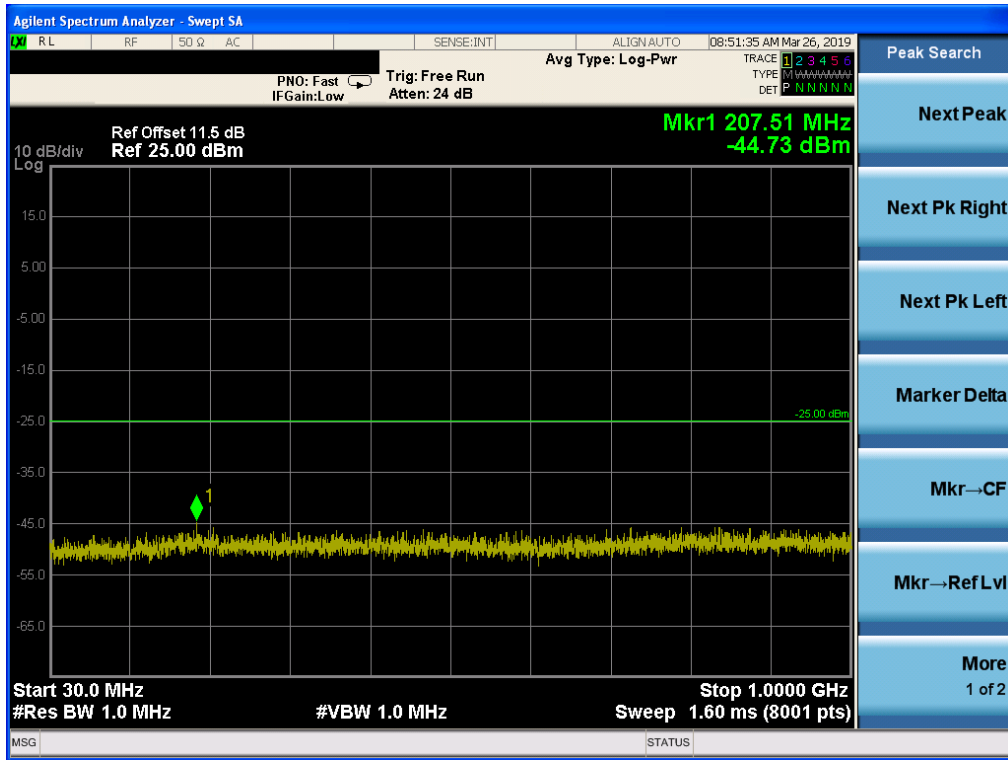

Band 7, UL Channel 20850, UL Frequency 2510.0, BW 20.0, NO. RB 100, RB POS. Low, QPSK

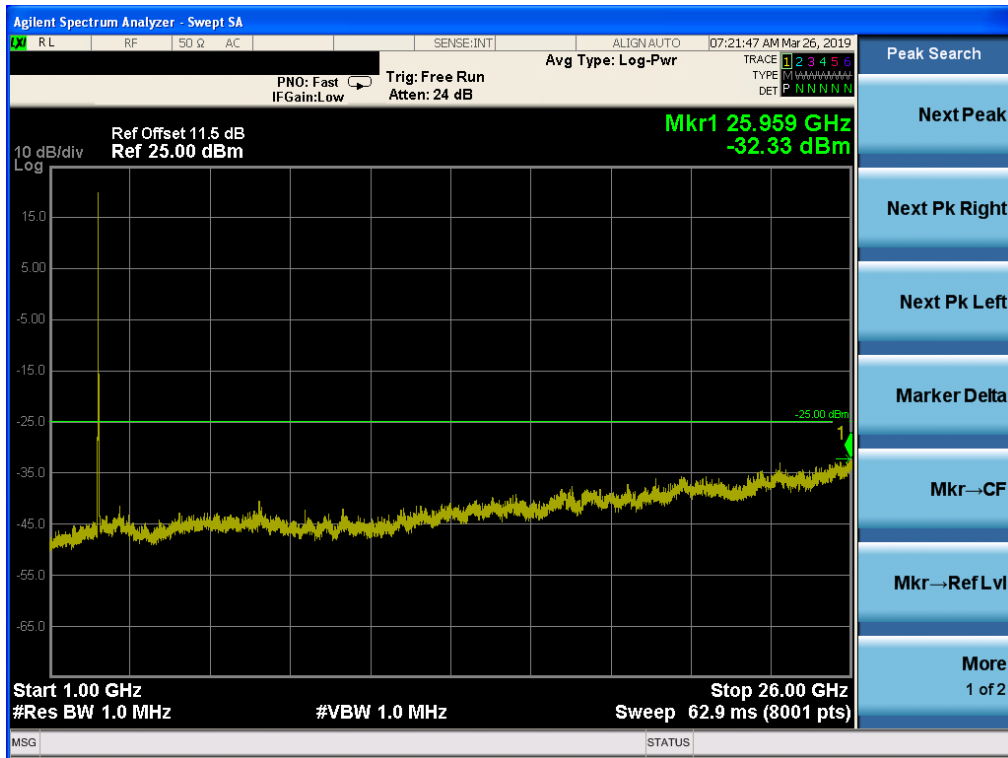

Band 7, UL Channel 20850, UL Frequency 2510.0, BW 20.0, NO. RB 100, RB POS. Low, 16-QAM

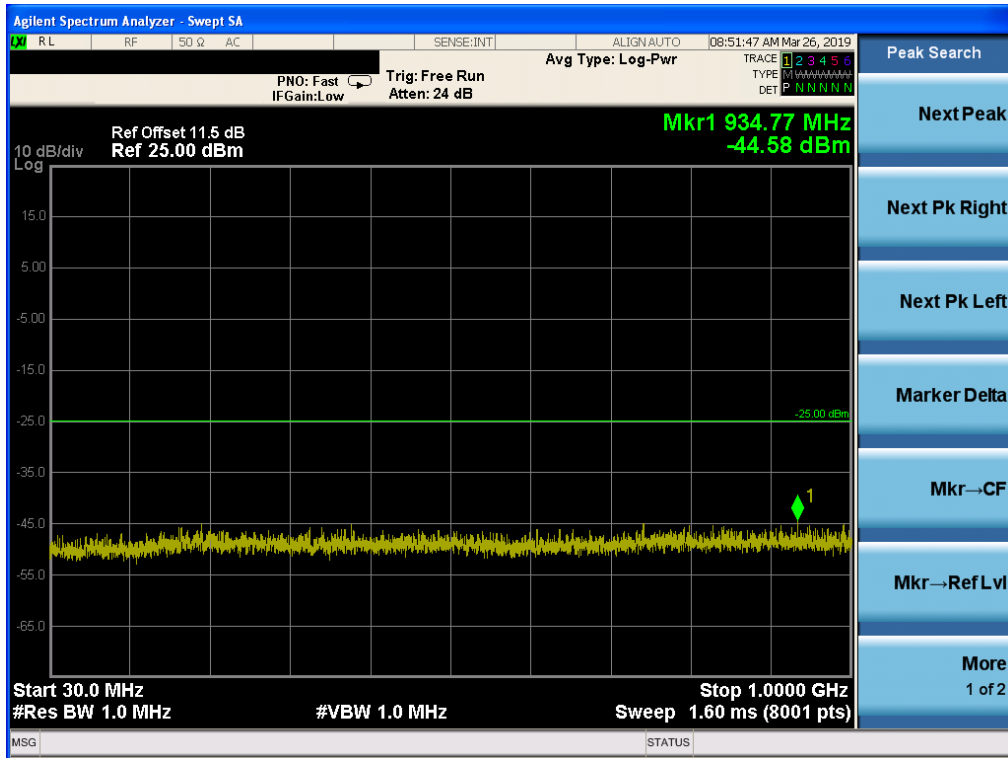

Band 7, UL Channel 20850, UL Frequency 2510.0, BW 20.0, NO. RB 100, RB POS. Low, 16-QAM

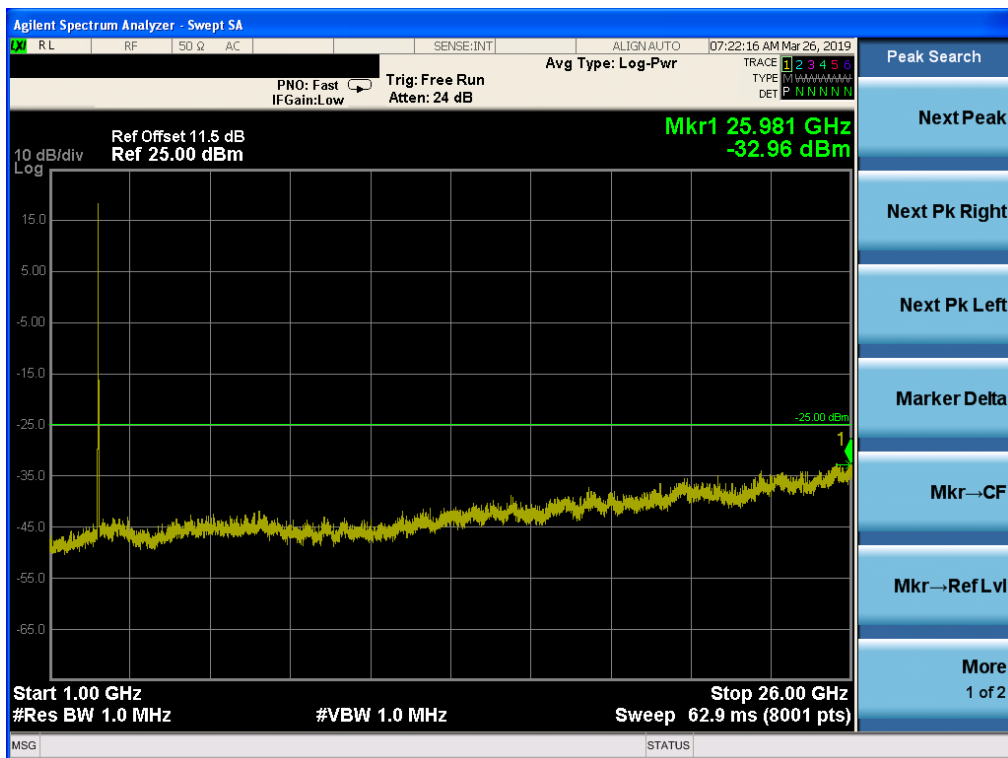

Band 7, UL Channel 21350, UL Frequency 2560.0, BW 20.0, NO. RB 100, RB POS. Low, QPSK

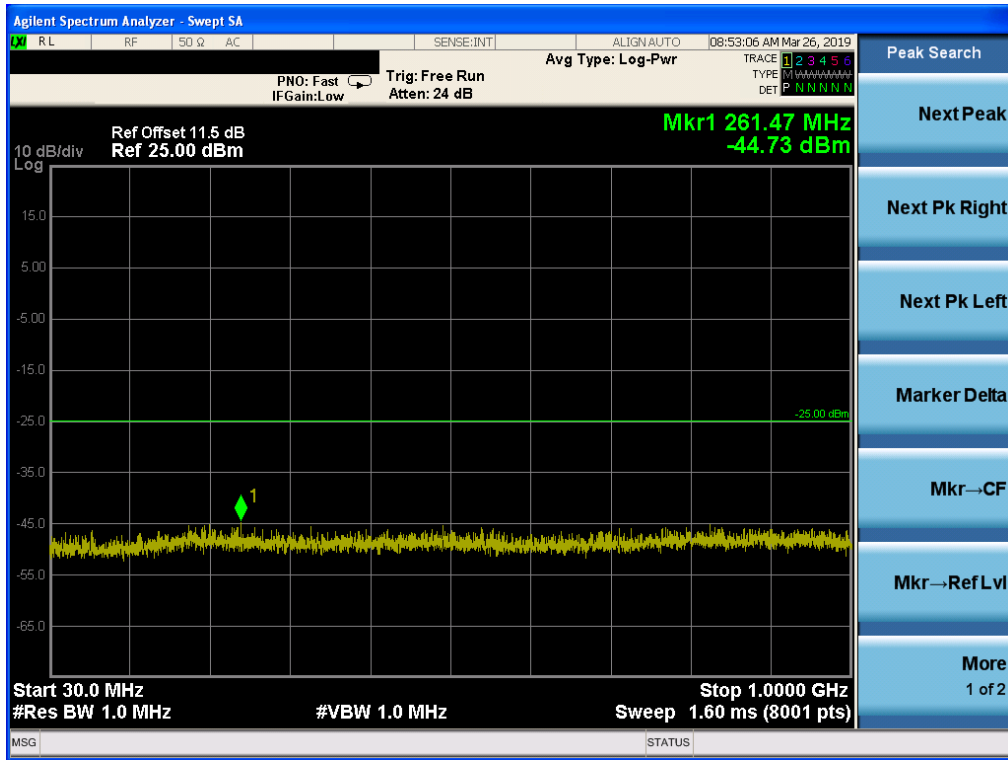

Band 7, UL Channel 21350, UL Frequency 2560.0, BW 20.0, NO. RB 100, RB POS. Low, QPSK

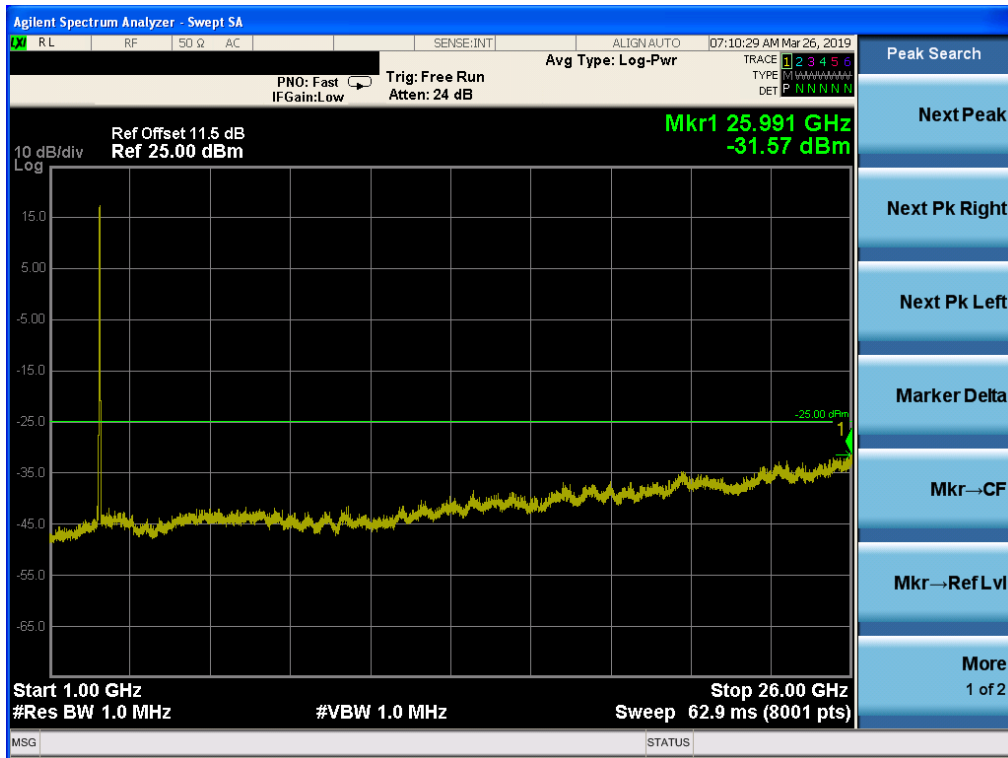

Band 7, UL Channel 21350, UL Frequency 2560.0, BW 20.0, NO. RB 100, RB POS. Low, 16-QAM

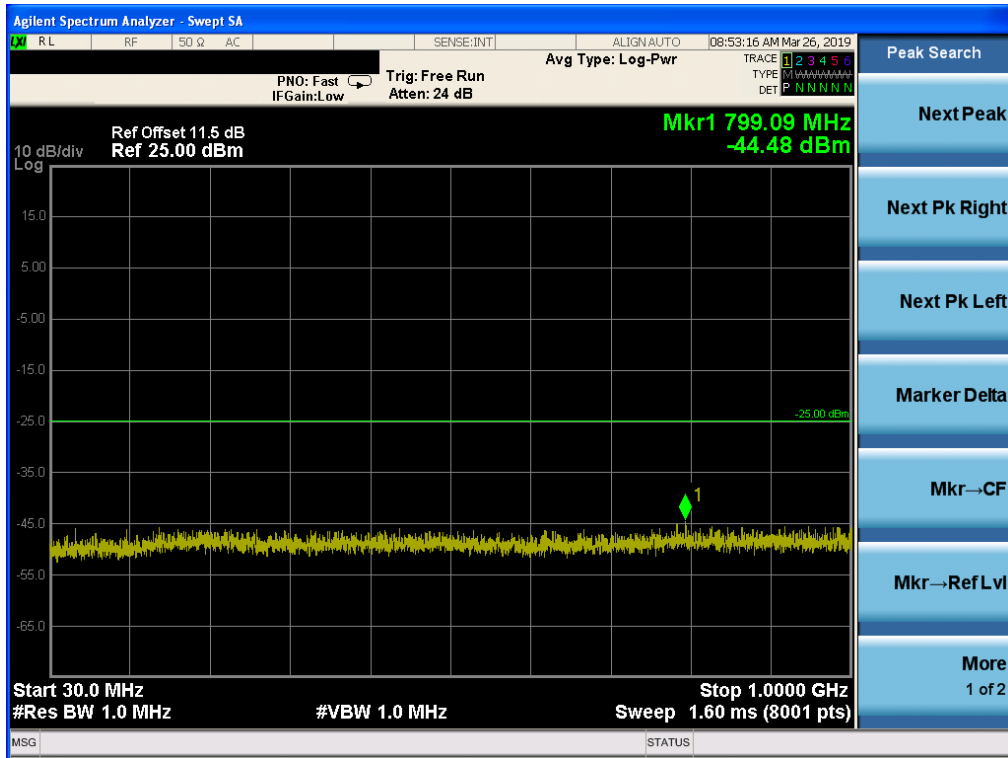

Band 7, UL Channel 21350, UL Frequency 2560.0, BW 20.0, NO. RB 100, RB POS. Low, 16-QAM

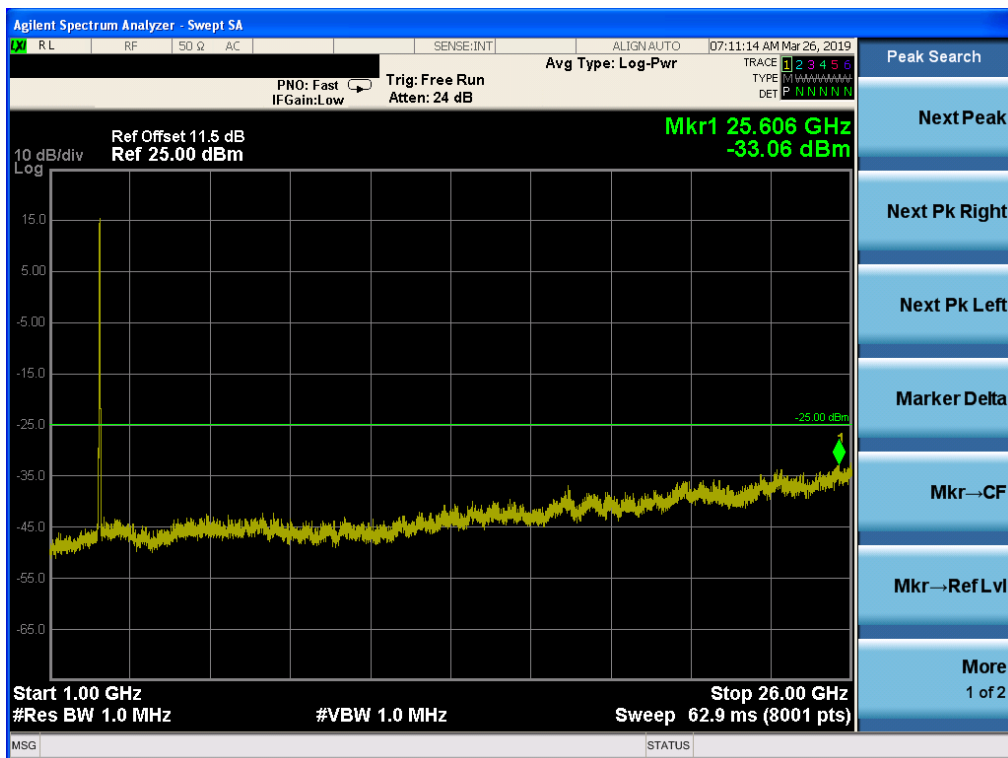

7.4 LTE BAND 41

Band 41, UL Channel 40440, UL Frequency 2575.0, BW 5.0, NO. RB 25, RB POS. Low, QPSK

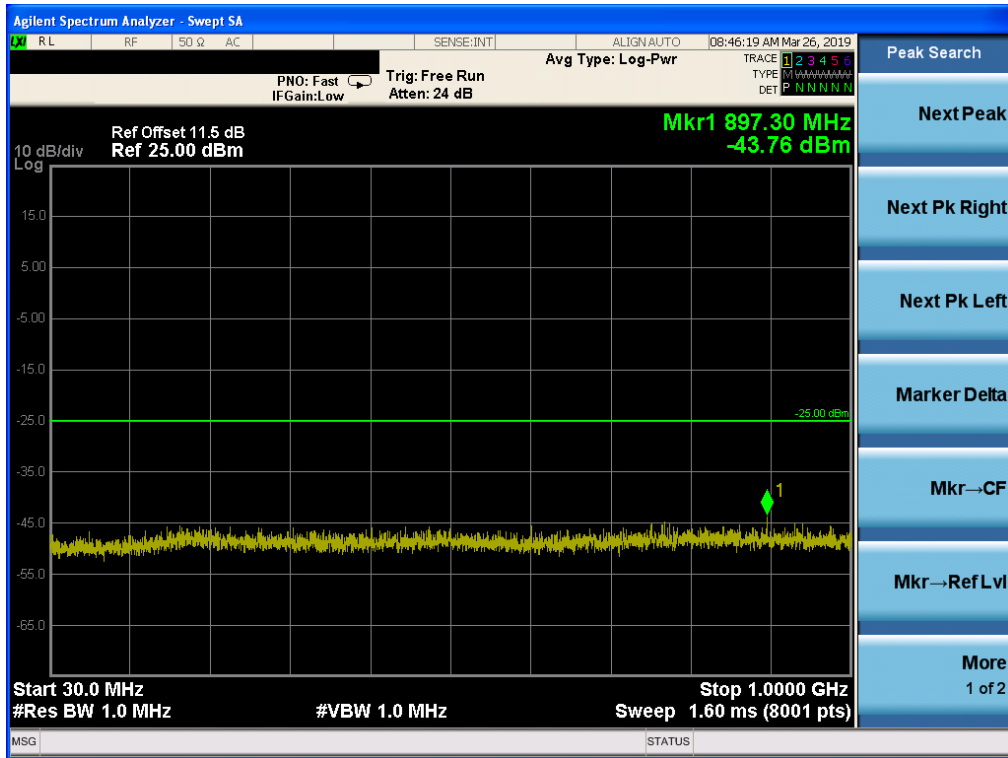

Band 41, UL Channel 40440, UL Frequency 2575.0, BW 5.0, NO. RB 25, RB POS. Low, QPSK

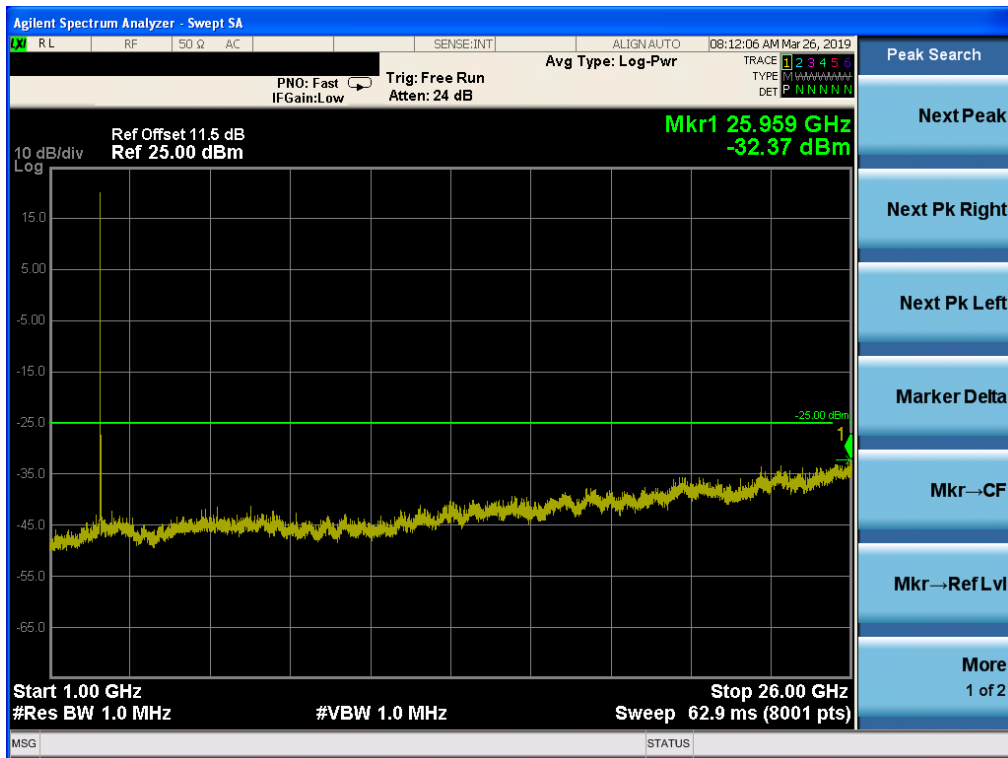

Band 41, UL Channel 40440, UL Frequency 2575.0, BW 5.0, NO. RB 25, RB POS. Low, 16-QAM

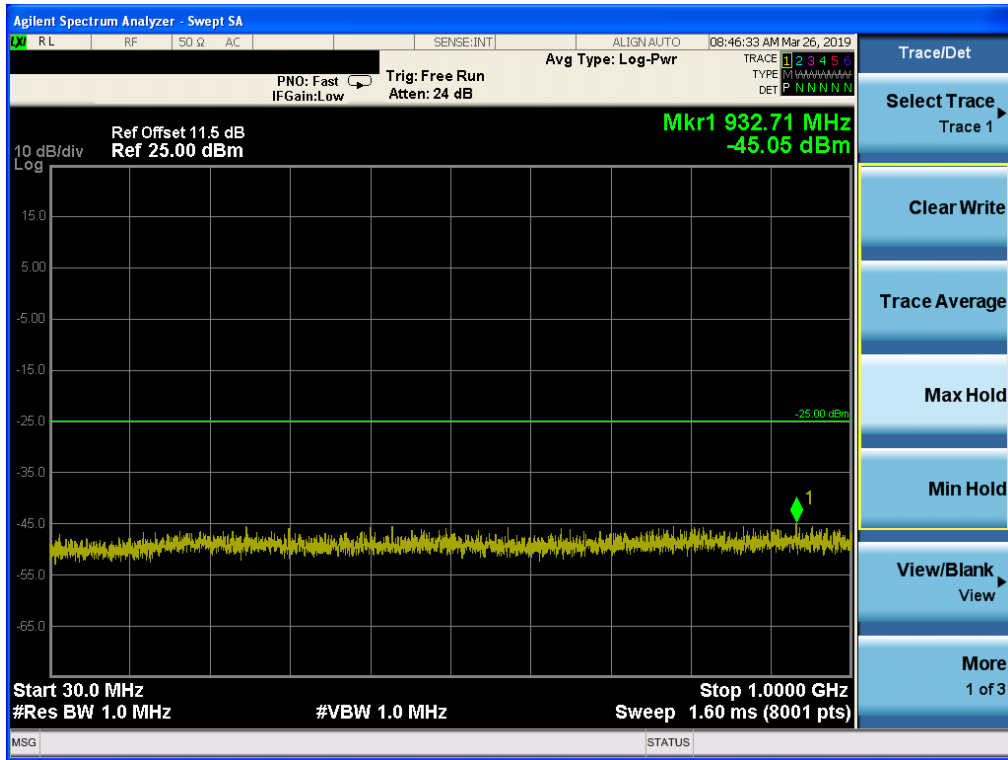

Band 41, UL Channel 40440, UL Frequency 2575.0, BW 5.0, NO. RB 25, RB POS. Low, 16-QAM

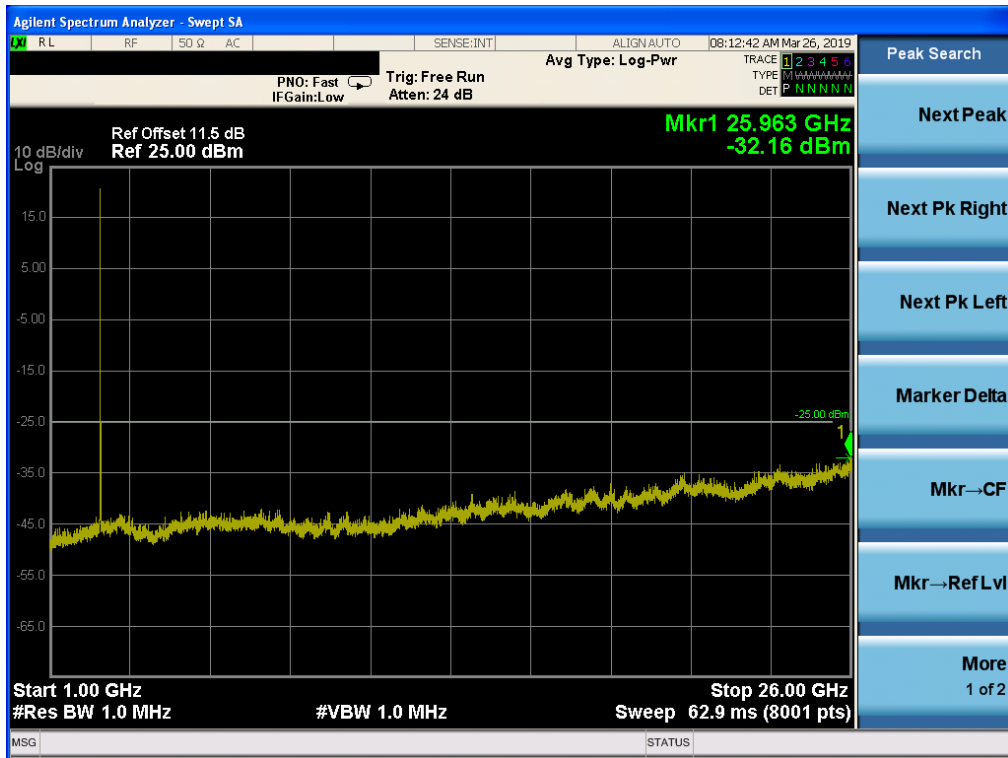

Band 41, UL Channel 41040, UL Frequency 2635.0, BW 5.0, NO. RB 25, RB POS. Low, QPSK

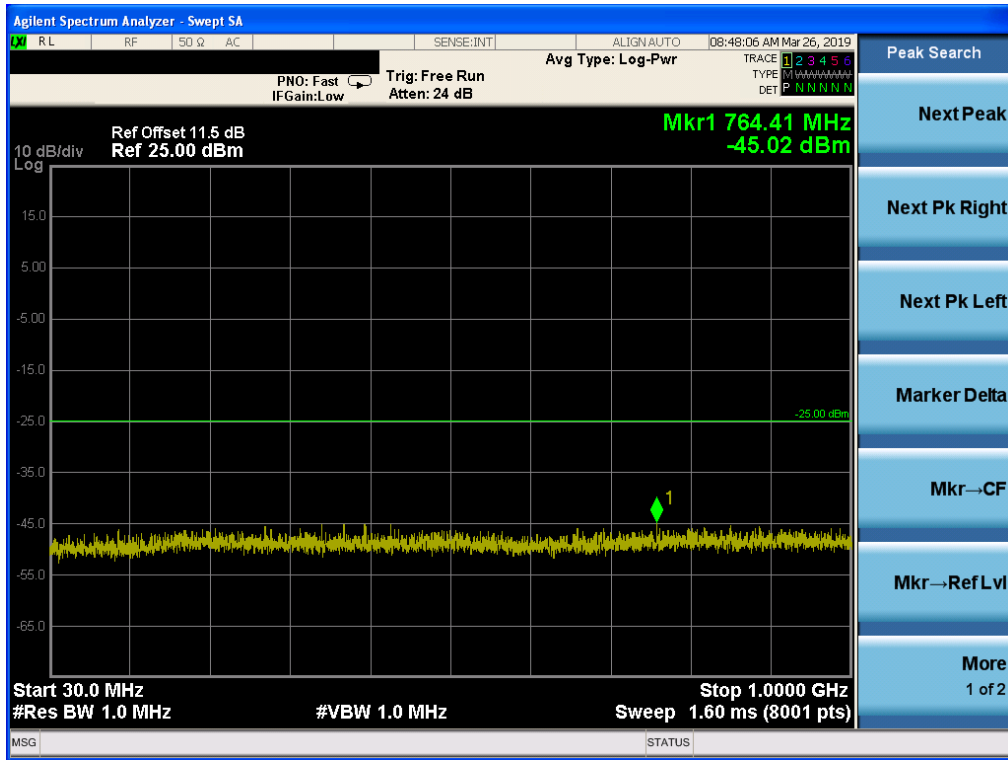

Band 41, UL Channel 41040, UL Frequency 2635.0, BW 5.0, NO. RB 25, RB POS. Low, QPSK

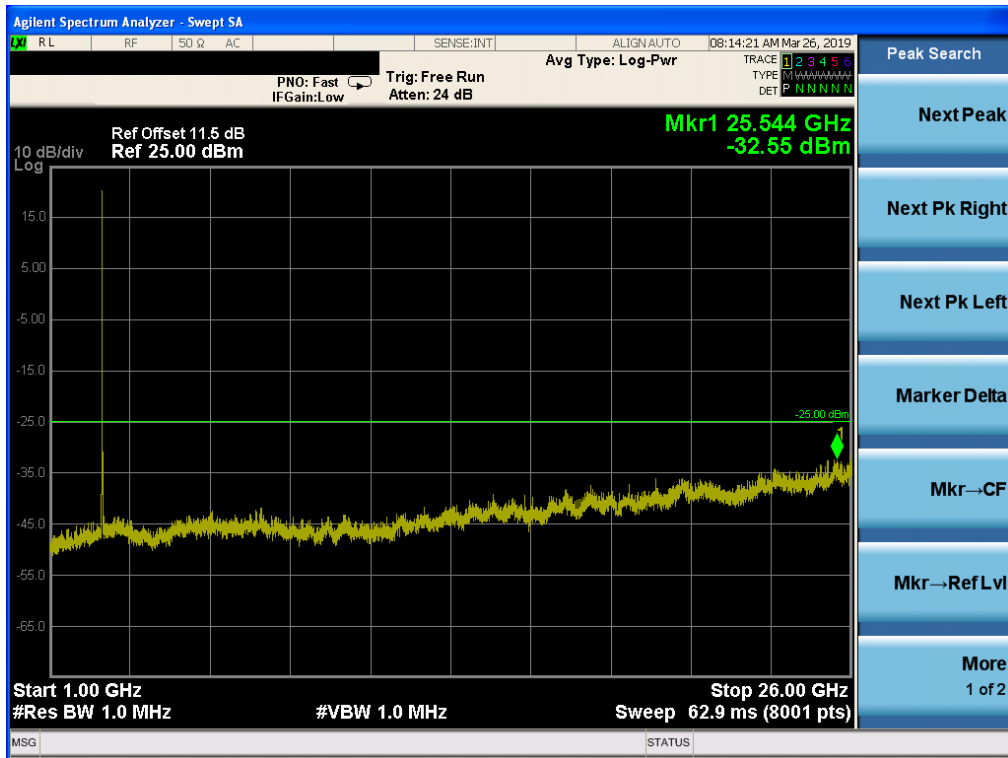

Band 41, UL Channel 41040, UL Frequency 2635.0, BW 5.0, NO. RB 25, RB POS. Low, 16-QAM

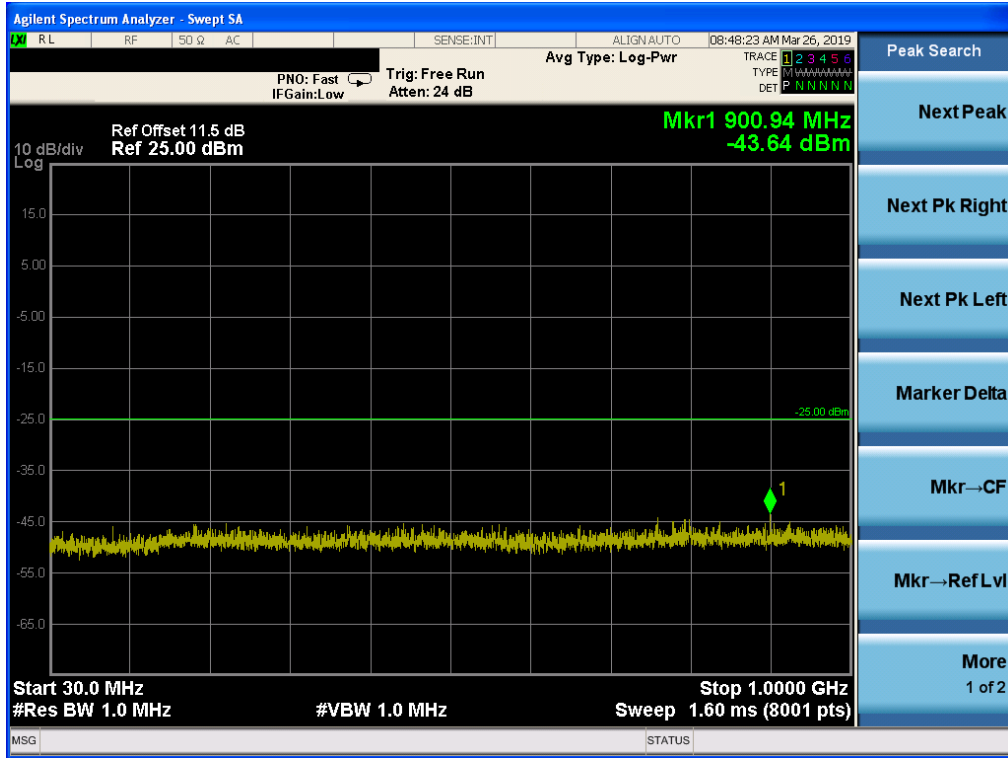

Band 41, UL Channel 41040, UL Frequency 2635.0, BW 5.0, NO. RB 25, RB POS. Low, 16-QAM

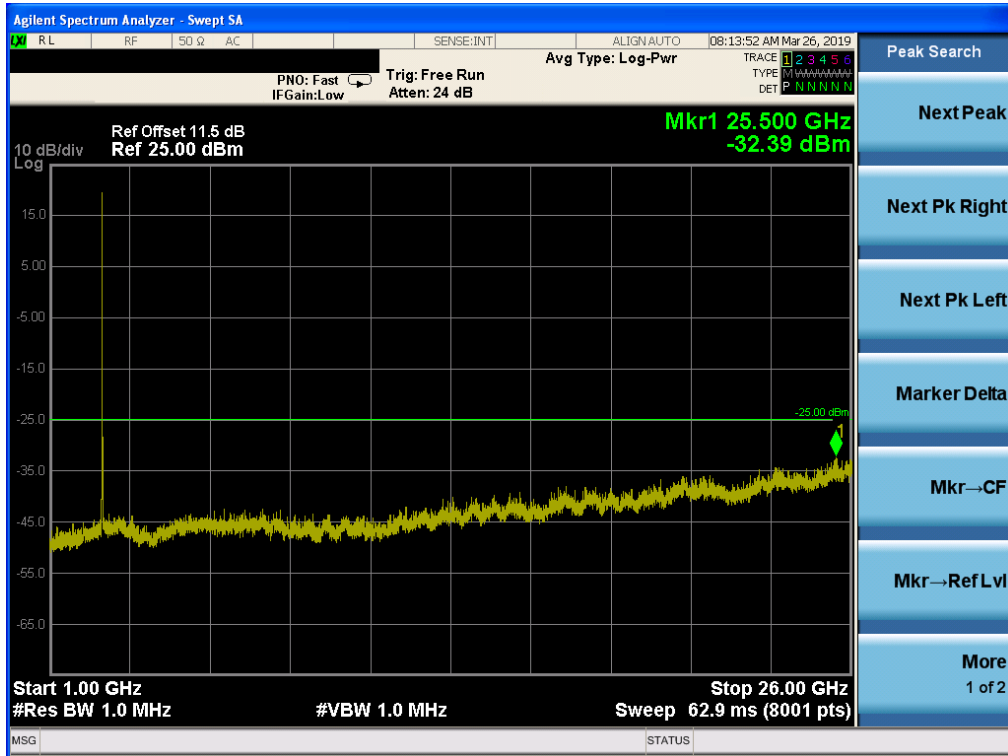

Band 41, UL Channel 40465, UL Frequency 2577.5, BW 10.0, NO. RB 50, RB POS. Low, QPSK

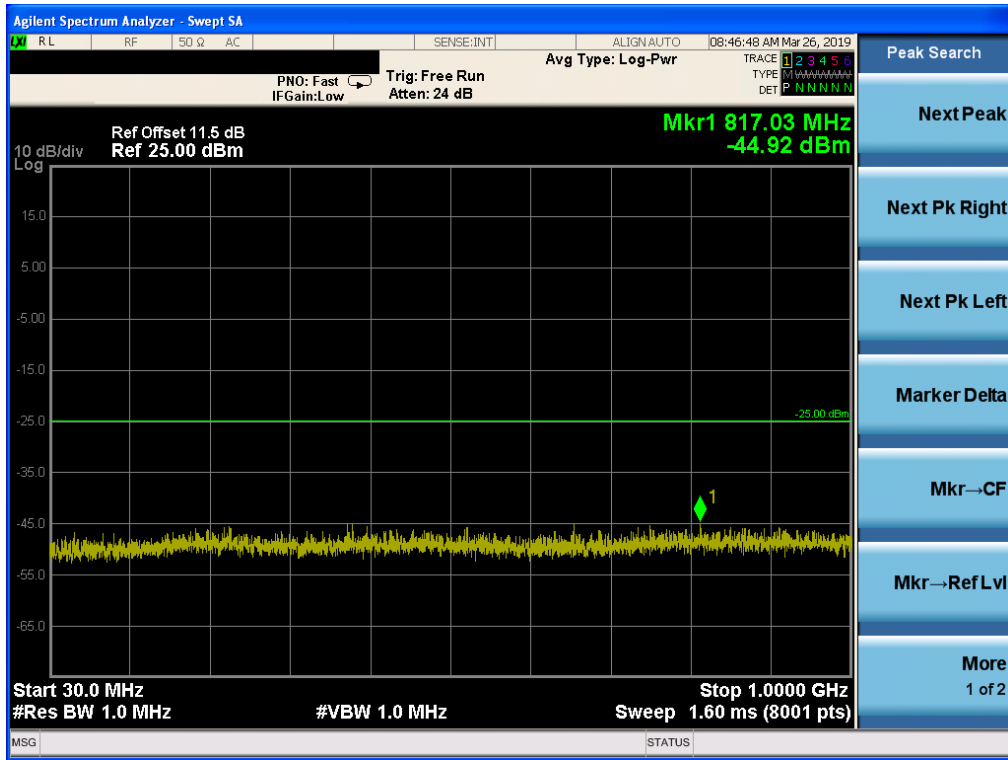

Band 41, UL Channel 40465, UL Frequency 2577.5, BW 10.0, NO. RB 50, RB POS. Low, QPSK

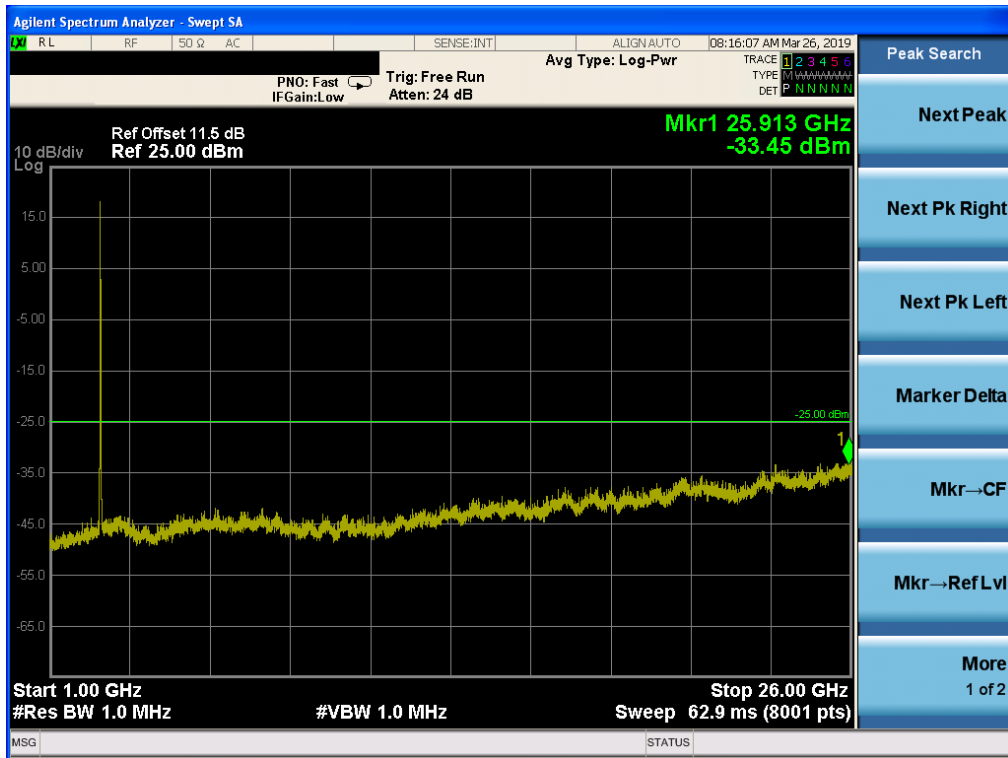

Band 41, UL Channel 40465, UL Frequency 2577.5, BW 10.0, NO. RB 50, RB POS. Low, 16-QAM

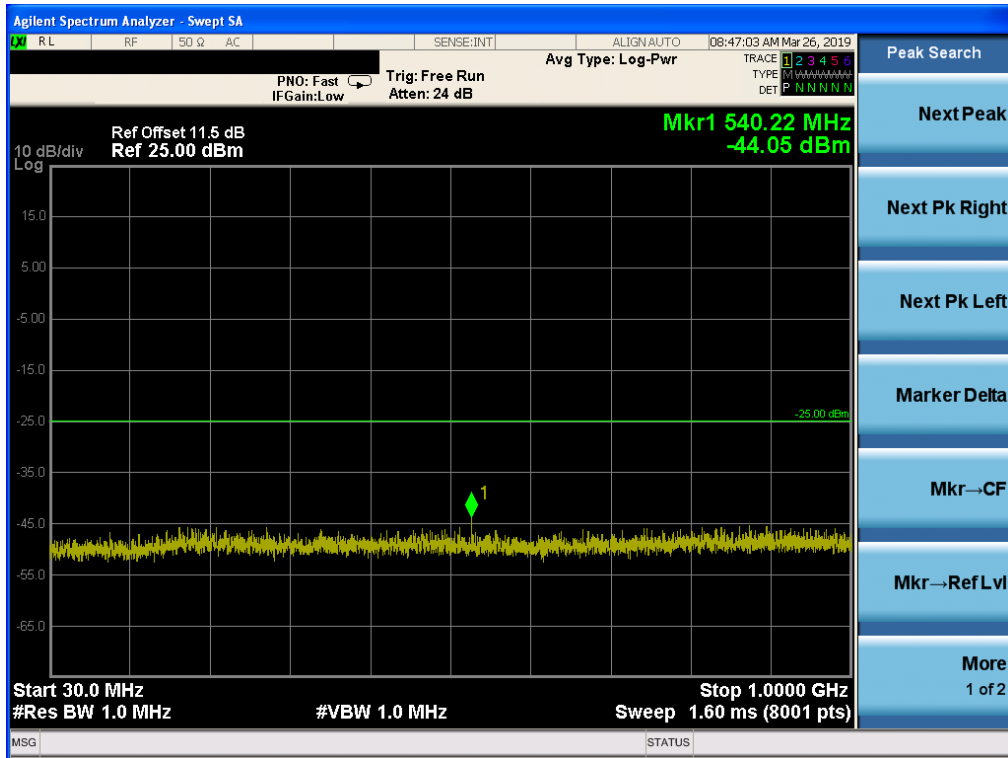

Band 41, UL Channel 40465, UL Frequency 2577.5, BW 10.0, NO. RB 50, RB POS. Low, 16-QAM

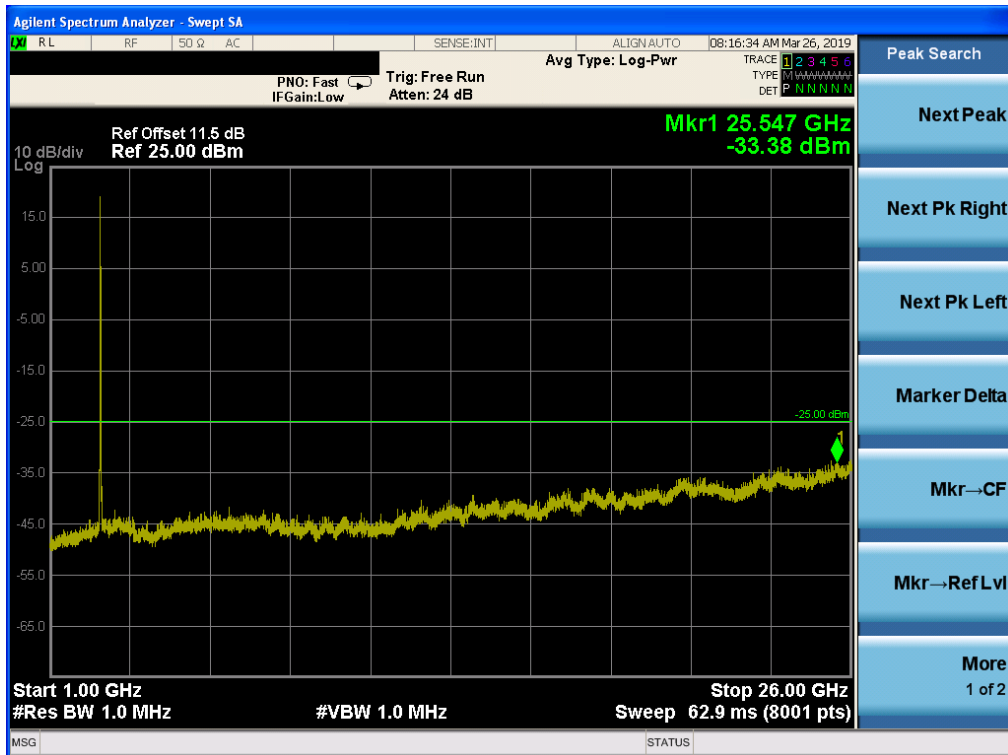

Band 41, UL Channel 41015, UL Frequency 2632.5, BW 10.0, NO. RB 50, RB POS. Low, QPSK

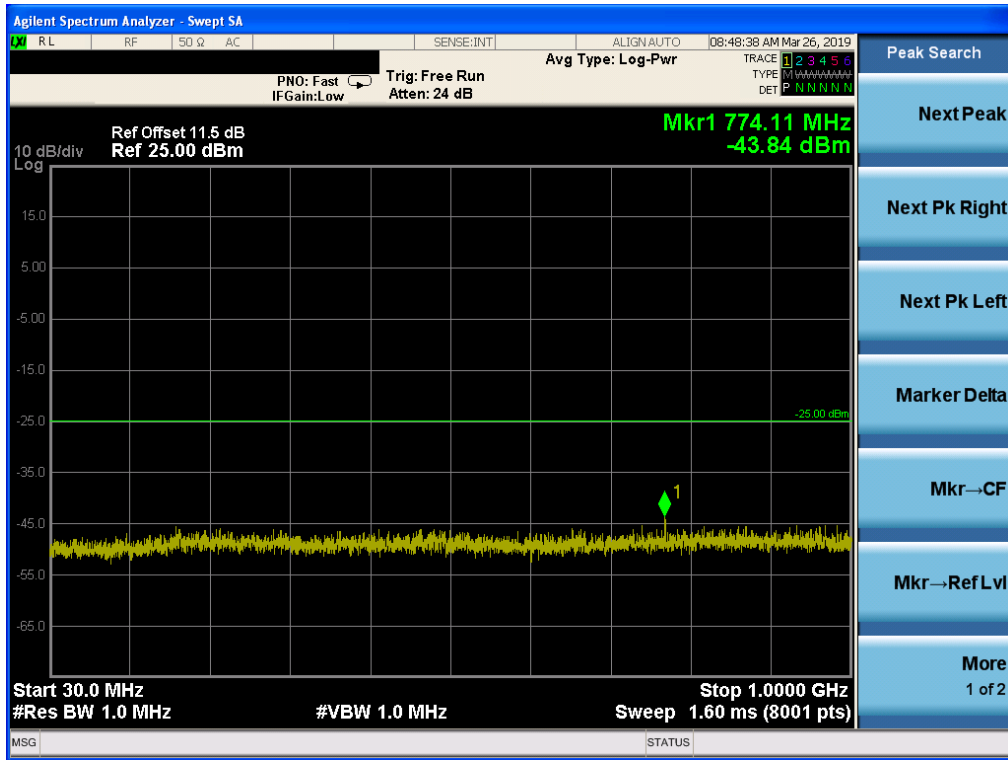

Band 41, UL Channel 41015, UL Frequency 2632.5, BW 10.0, NO. RB 50, RB POS. Low, QPSK

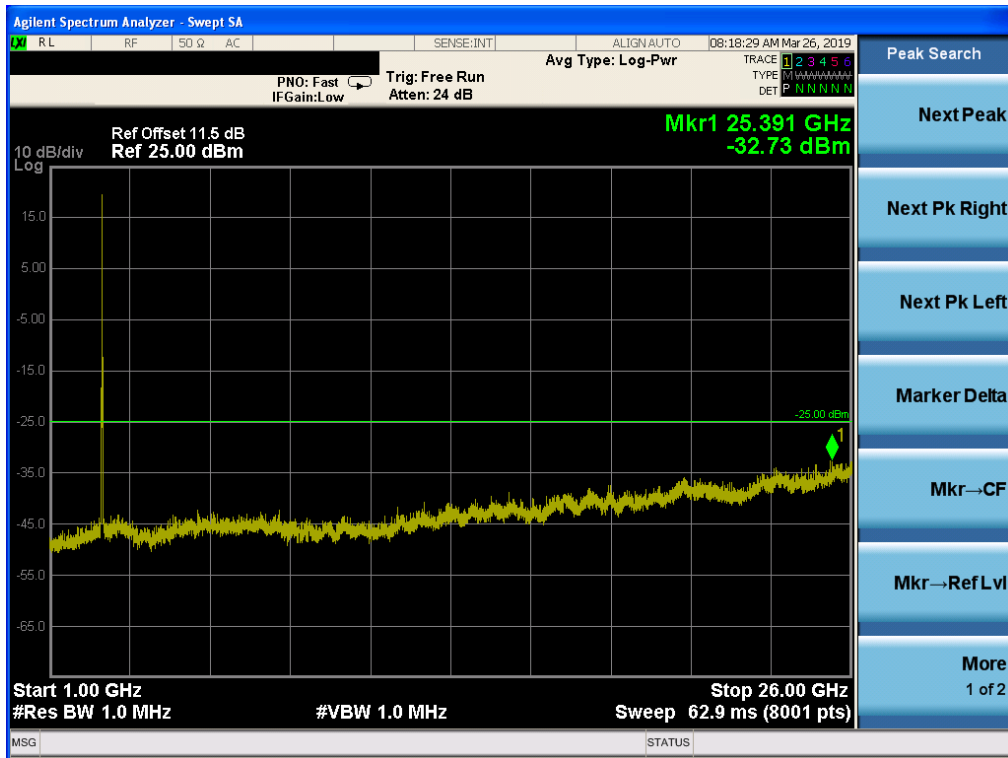

Band 41, UL Channel 41015, UL Frequency 2632.5, BW 10.0, NO. RB 50, RB POS. Low, 16-QAM

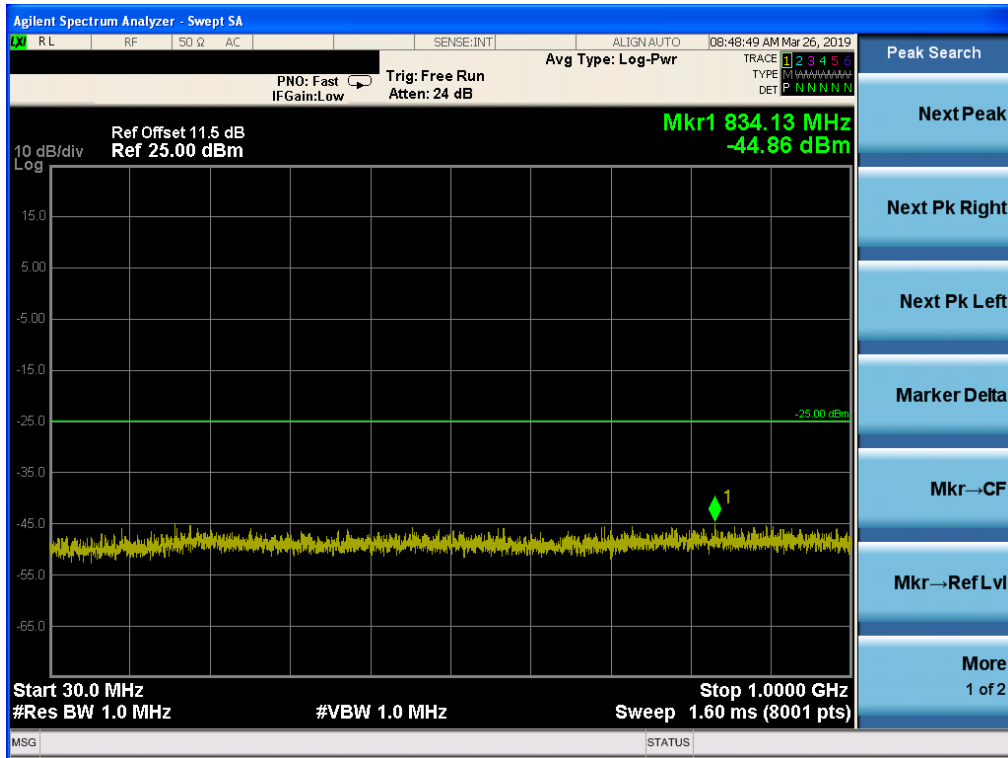

Band 41, UL Channel 41015, UL Frequency 2632.5, BW 10.0, NO. RB 50, RB POS. Low, 16-QAM

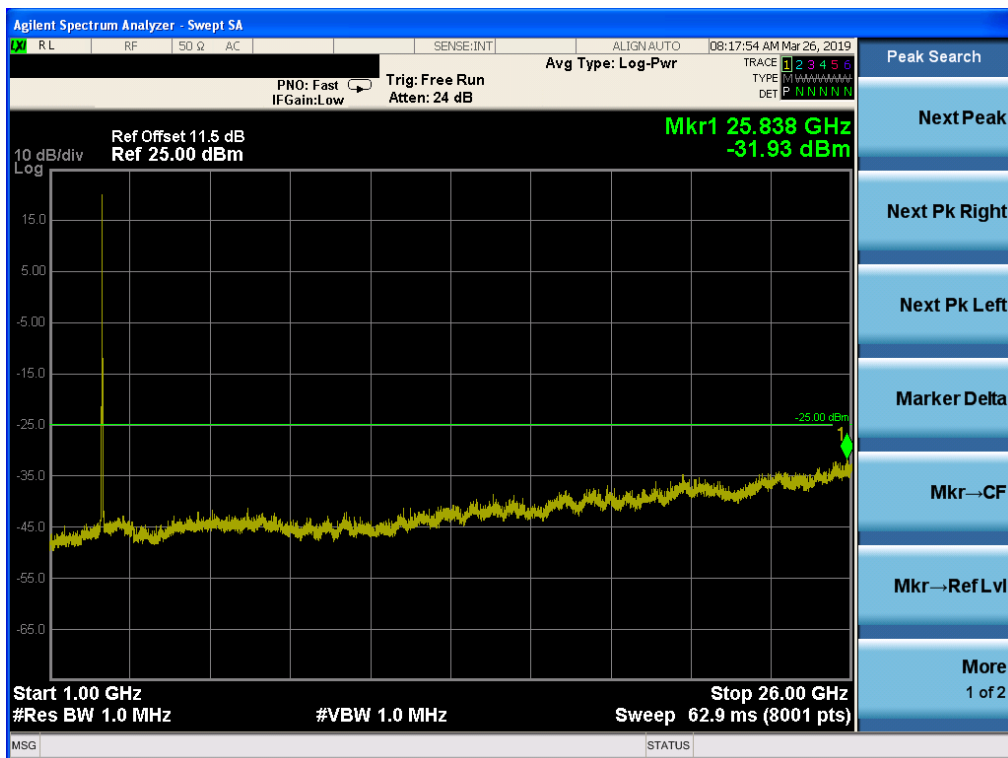

Band 41, UL Channel 40490, UL Frequency 2580.0, BW 15.0, NO. RB 75, RB POS. Low, QPSK

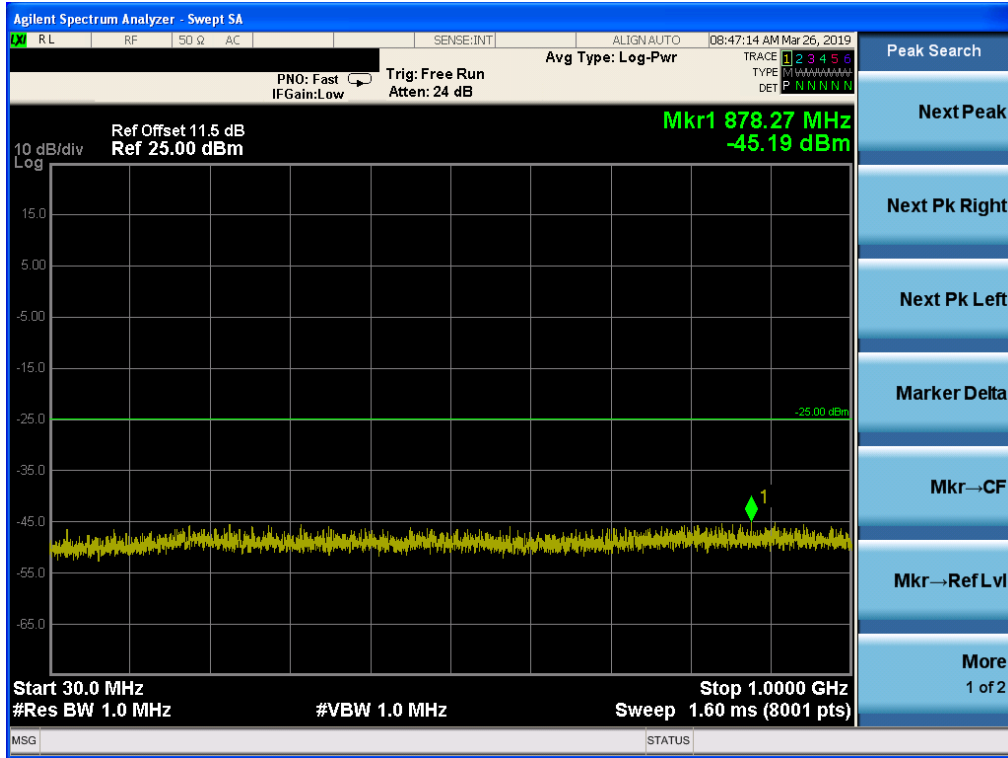

Band 41, UL Channel 40490, UL Frequency 2580.0, BW 15.0, NO. RB 75, RB POS. Low, QPSK

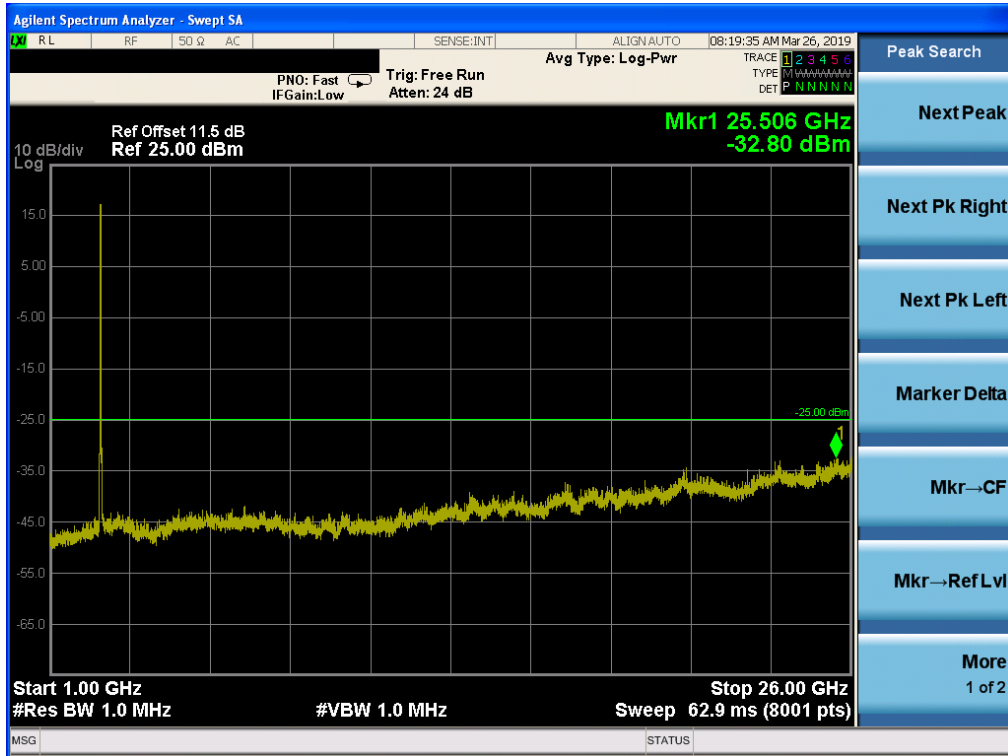

Band 41, UL Channel 40490, UL Frequency 2580.0, BW 15.0, NO. RB 75, RB POS. Low, 16-QAM

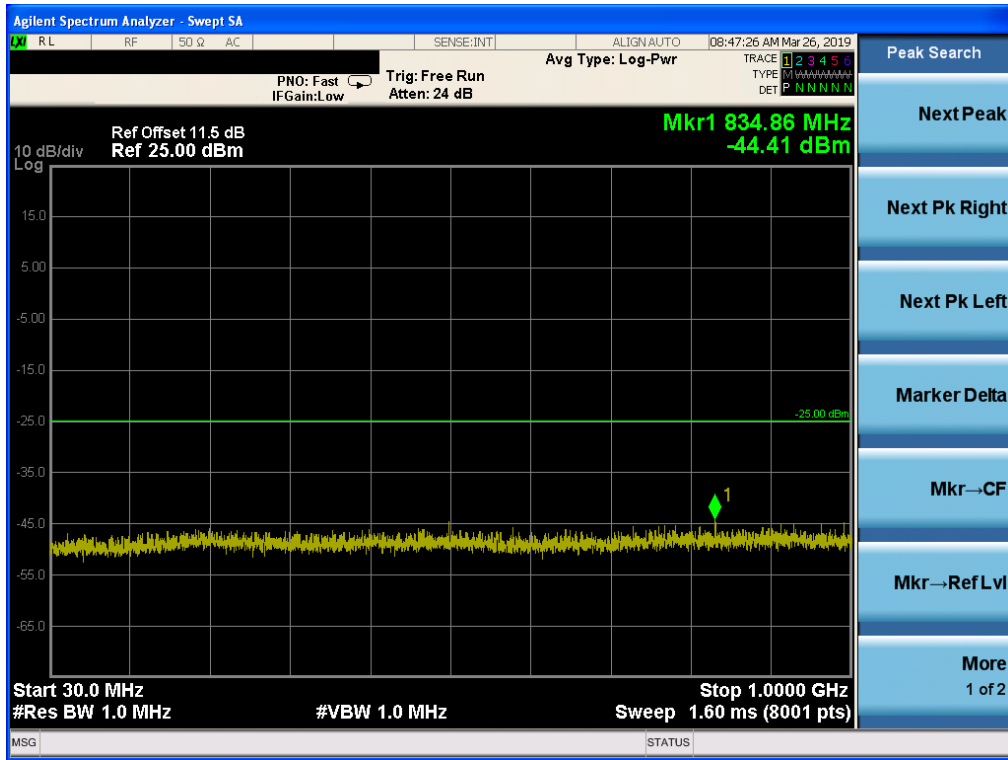

Band 41, UL Channel 40490, UL Frequency 2580.0, BW 15.0, NO. RB 75, RB POS. Low, 16-QAM

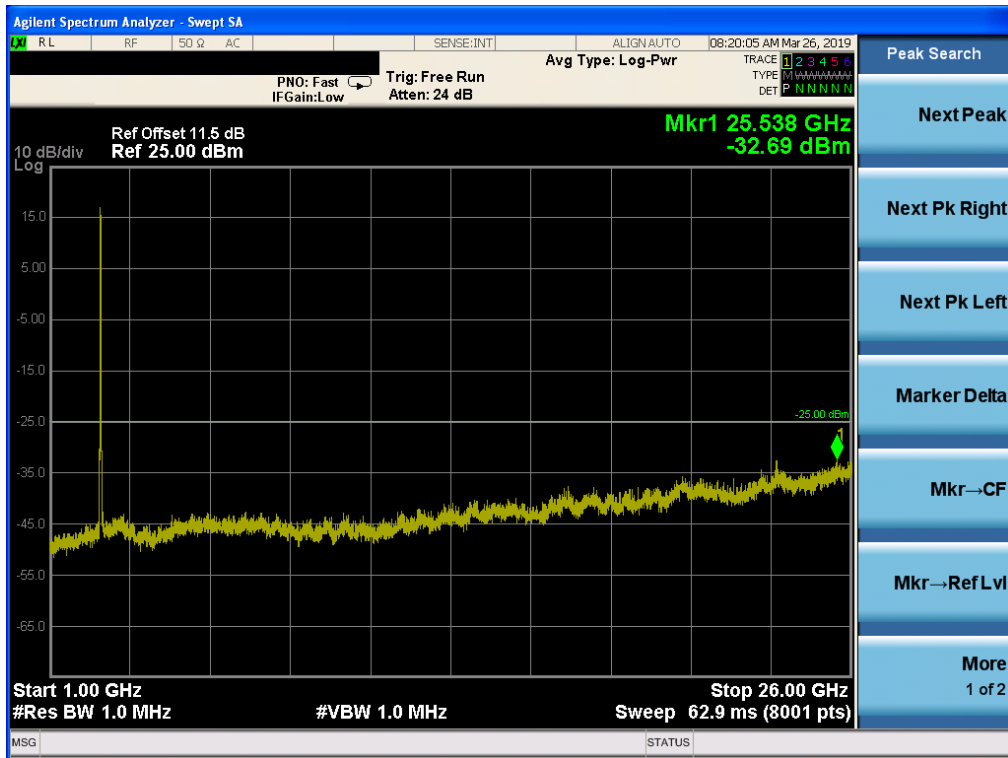

Band 41, UL Channel 40990, UL Frequency 2630.0, BW 15.0, NO. RB 75, RB POS. Low, QPSK

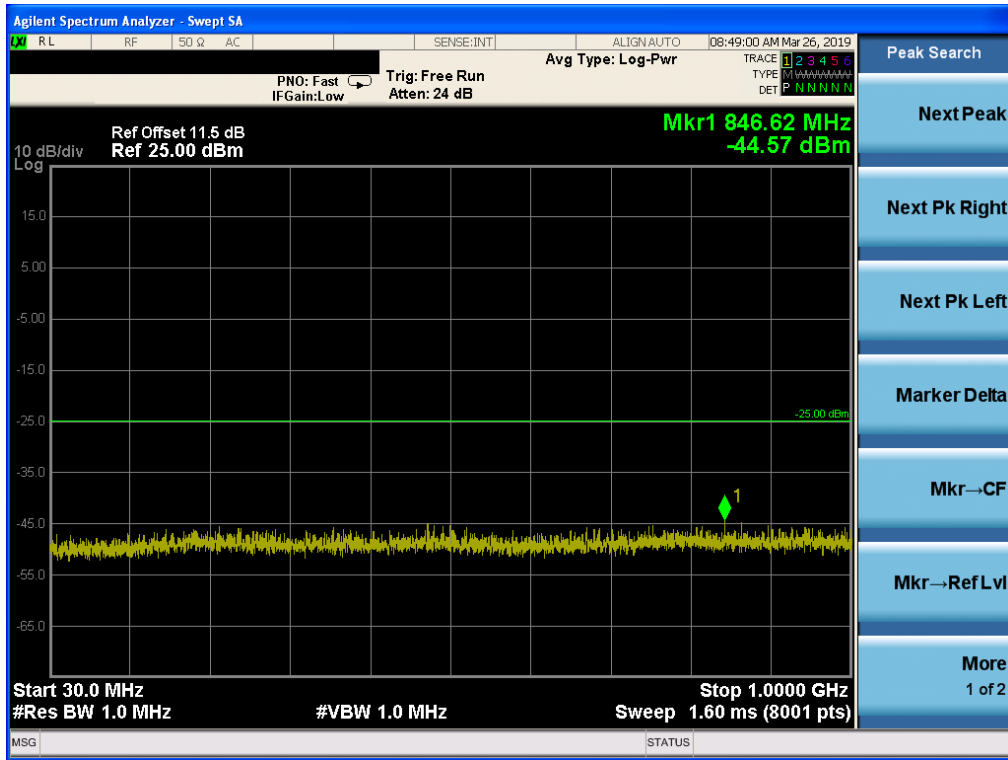

Band 41, UL Channel 40990, UL Frequency 2630.0, BW 15.0, NO. RB 75, RB POS. Low, QPSK

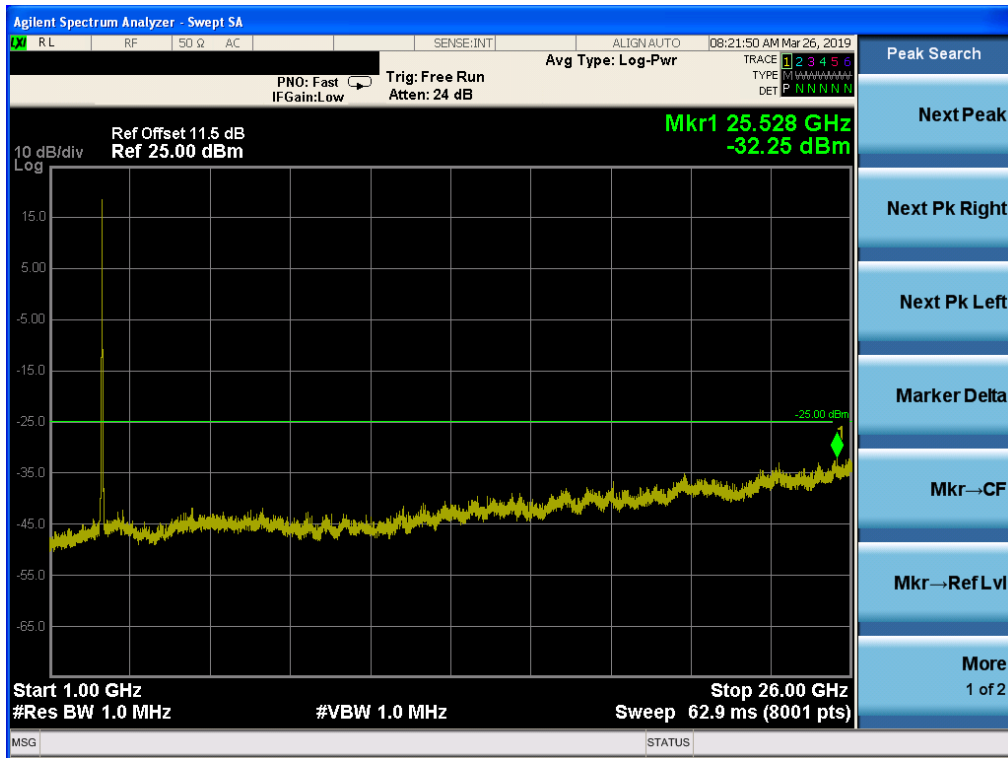

Band 41, UL Channel 40990, UL Frequency 2630.0, BW 15.0, NO. RB 75, RB POS. Low, 16-QAM

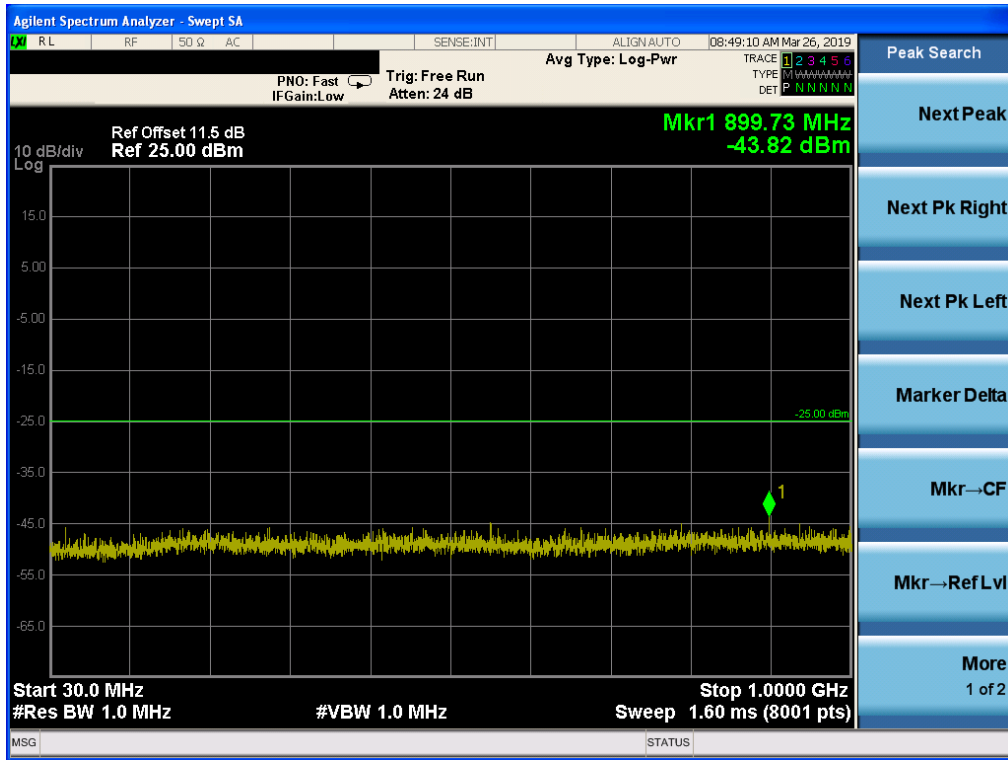

Band 41, UL Channel 40990, UL Frequency 2630.0, BW 15.0, NO. RB 75, RB POS. Low, 16-QAM

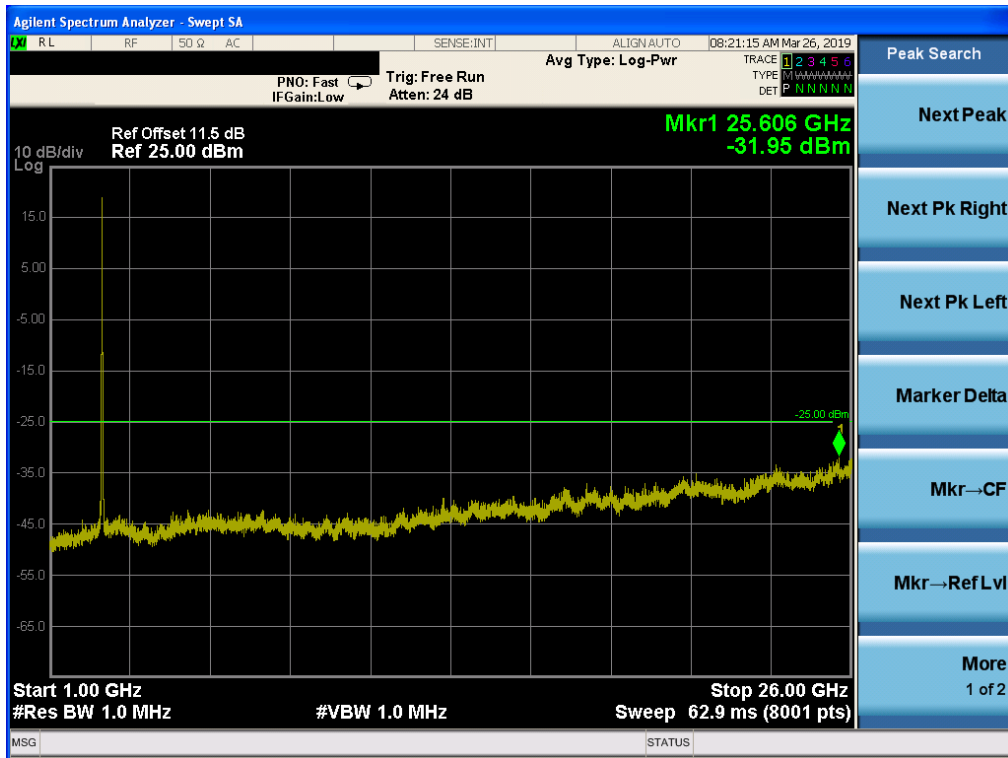

Band 41, UL Channel 40515, UL Frequency 2582.5, BW 20.0, NO. RB 100, RB POS. Low, QPSK

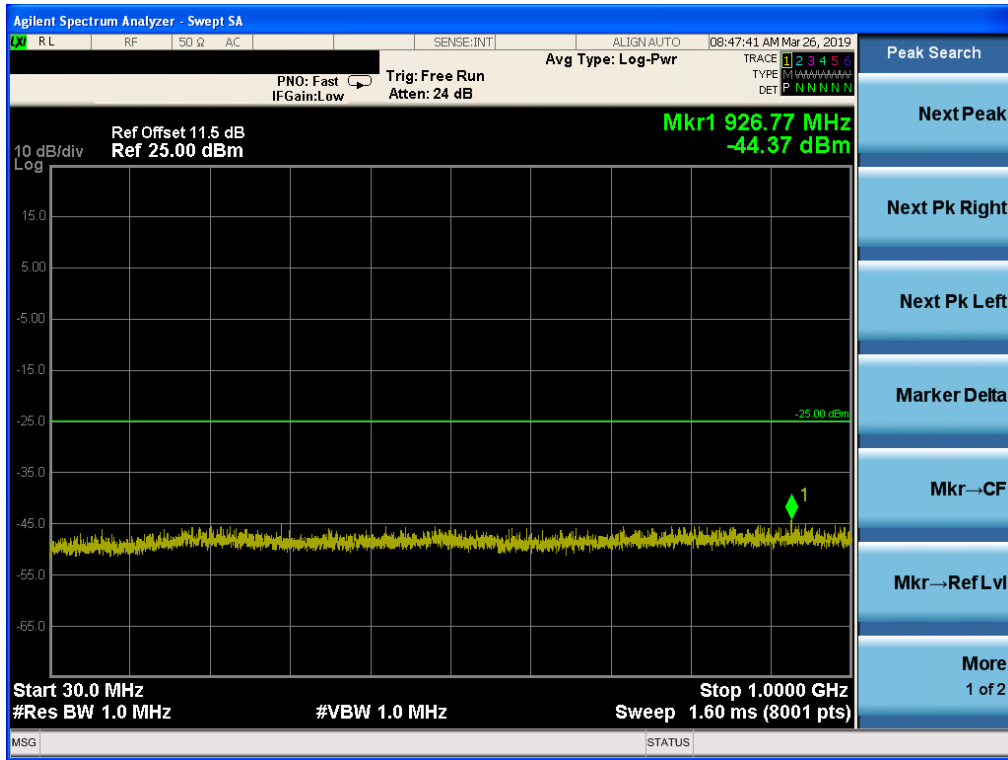

Band 41, UL Channel 40515, UL Frequency 2582.5, BW 20.0, NO. RB 100, RB POS. Low, QPSK

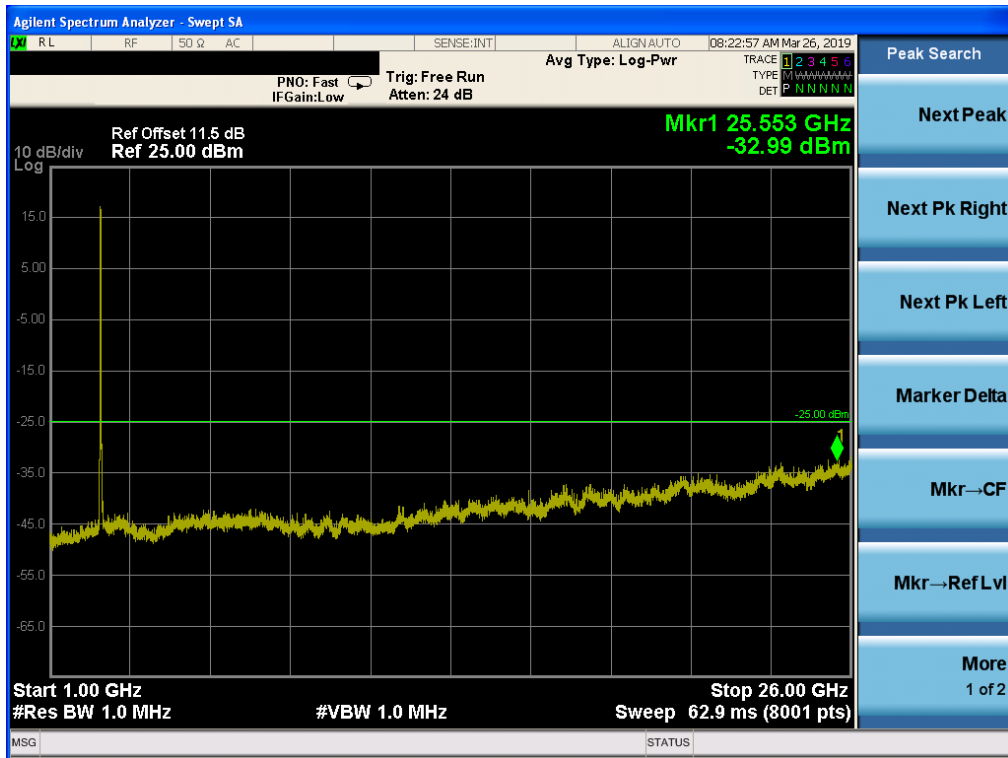

Band 41, UL Channel 40515, UL Frequency 2582.5, BW 20.0, NO. RB 100, RB POS. Low, 16-QAM

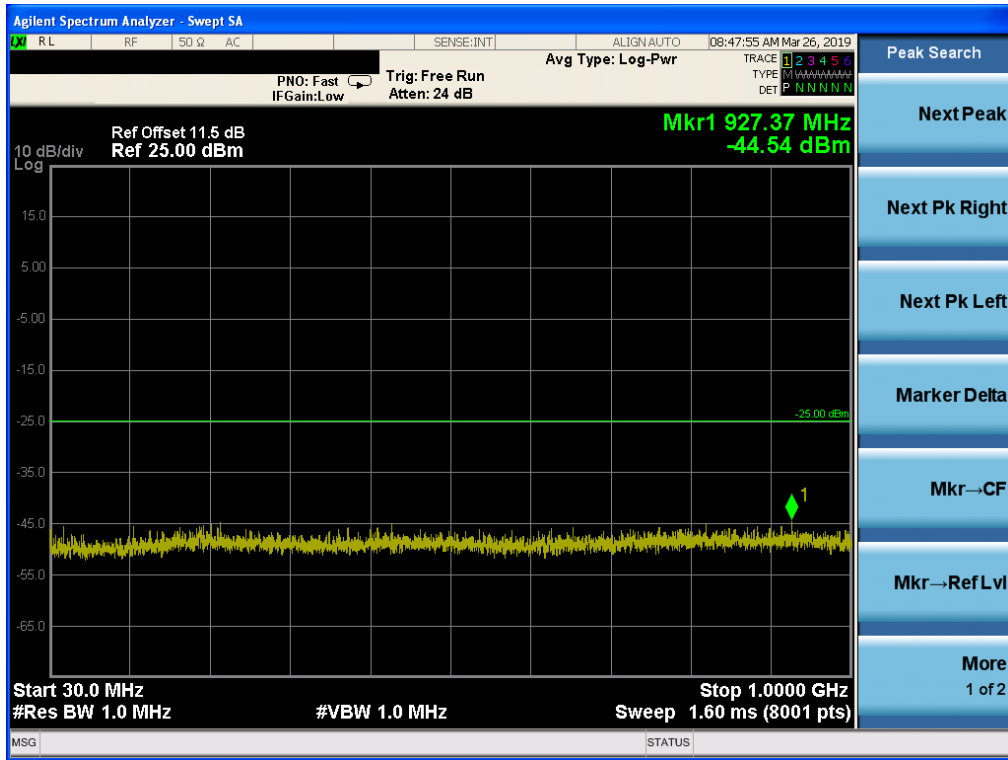

Band 41, UL Channel 40515, UL Frequency 2582.5, BW 20.0, NO. RB 100, RB POS. Low, 16-QAM

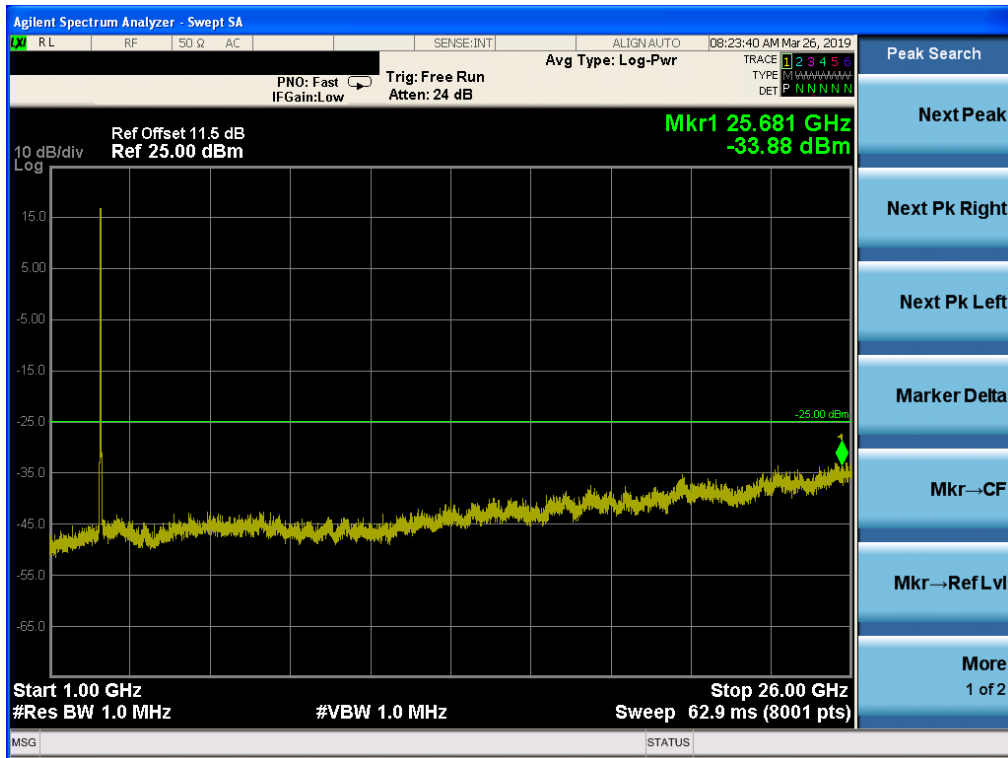

Band 41, UL Channel 40965, UL Frequency 2627.5, BW 20.0, NO. RB 100, RB POS. Low, QPSK

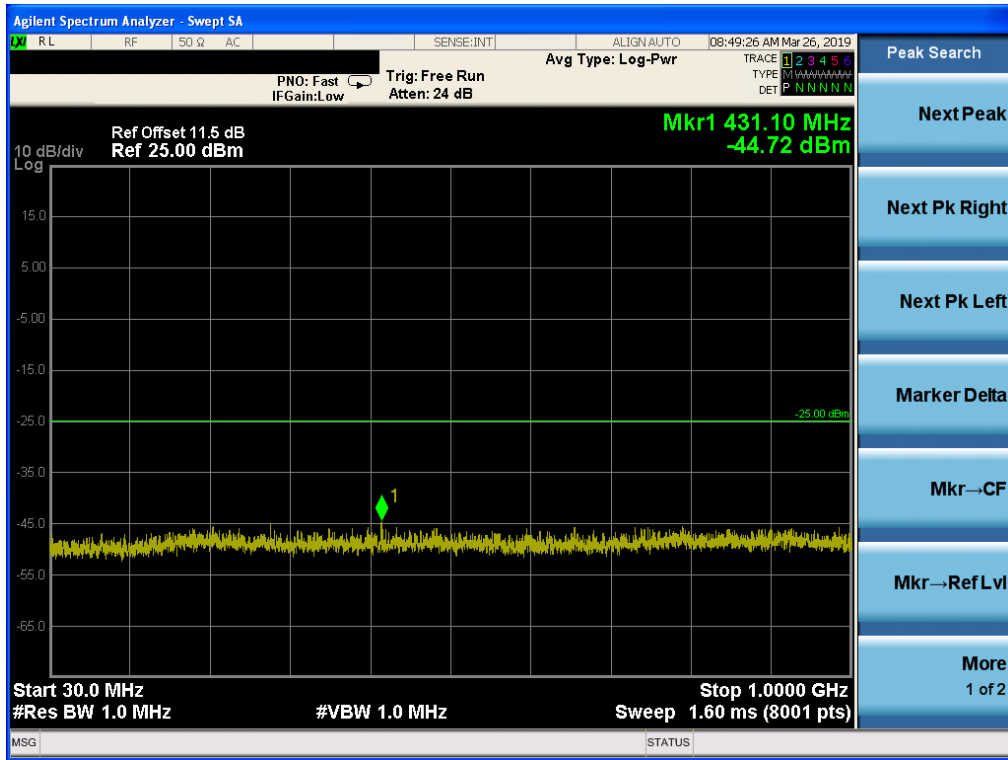

Band 41, UL Channel 40965, UL Frequency 2627.5, BW 20.0, NO. RB 100, RB POS. Low, QPSK

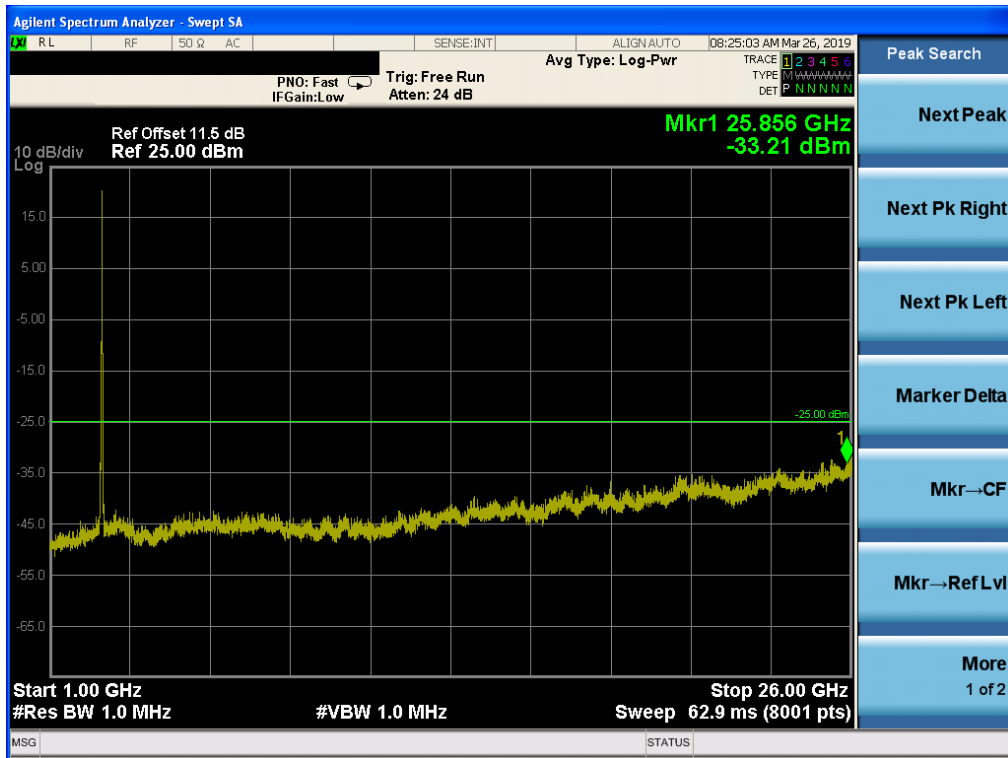

Band 41, UL Channel 40965, UL Frequency 2627.5, BW 20.0, NO. RB 100, RB POS. Low, 16-QAM

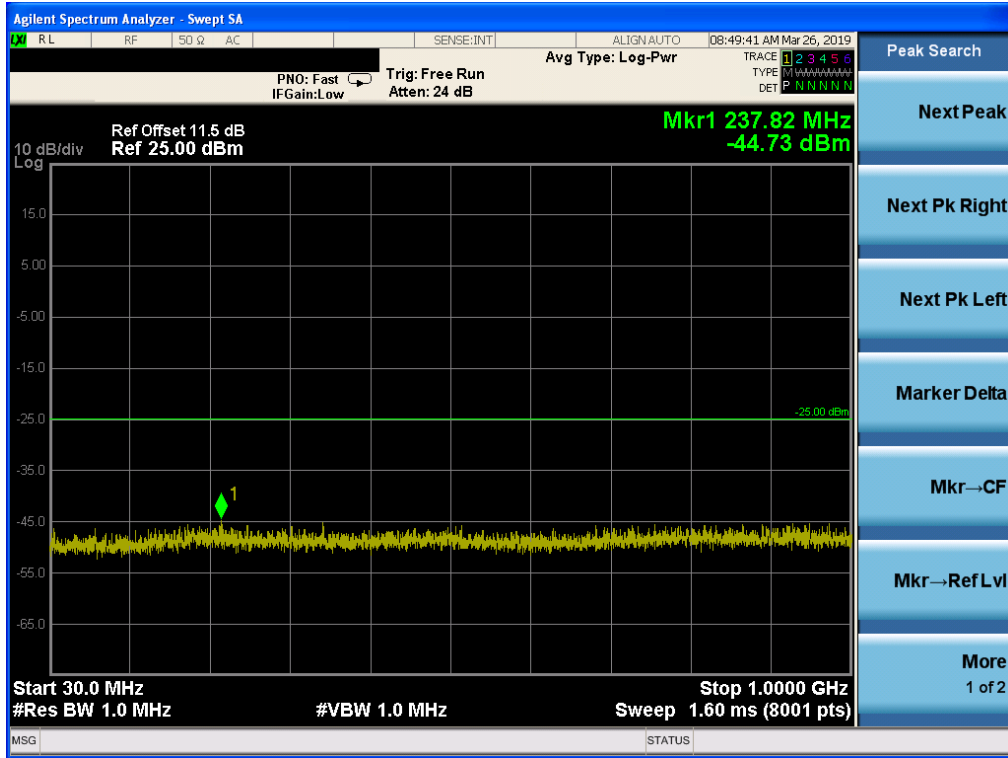

Band 41, UL Channel 40965, UL Frequency 2627.5, BW 20.0, NO. RB 100, RB POS. Low, 16-QAM

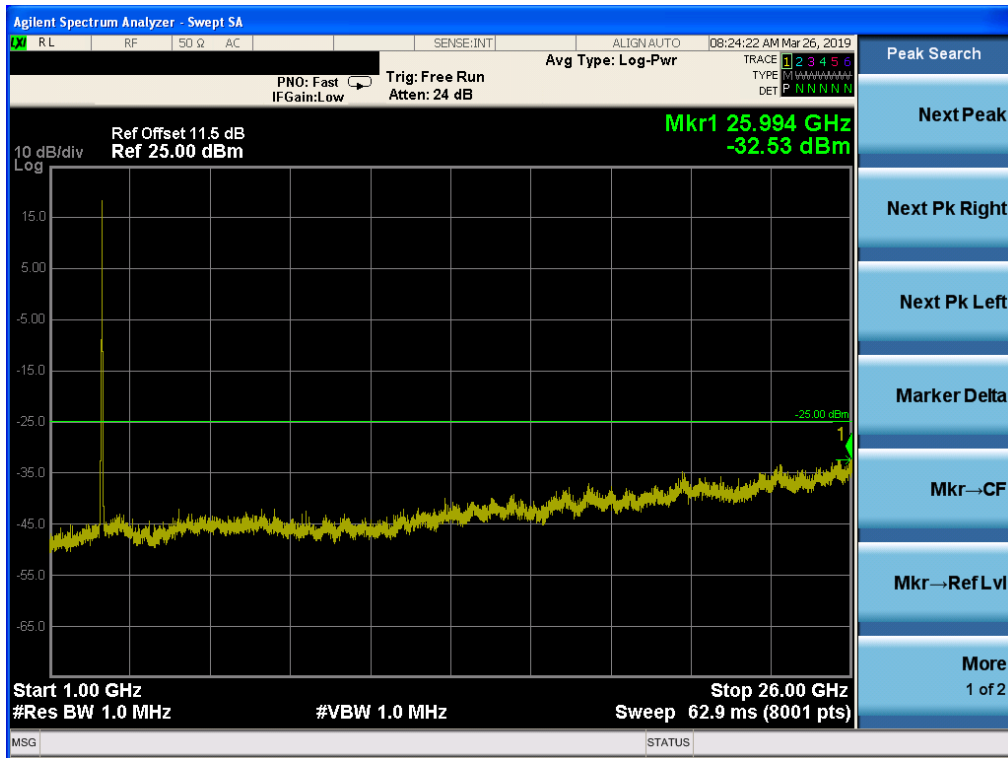

## 8. RADIATED MEASUREMENT

### 8.1. RADIATED POWER (ERP & EIRP)

#### **RULE PART(S)**

FCC: §2.1046, §22.913 and §27.50

#### **LIMITS:**

22.913(a) - The ERP of mobile transmitters and auxiliary test transmitters must not exceed 7 Watts.

27.50 (c) (10) the following power and antenna height requirements apply to stations transmitting in the 698–746 MHz band, the portable stations (hand-held devices) are limited to 3 watts ERP.

27.50 (b)(10) Portable stations (hand-held devices) transmitting in the 746–757 MHz, 758–763 MHz, 776–793 MHz, and 805–806 MHz bands are limited to 3 watts ERP.

27.50 (d)(4) The following power and antenna height requirements apply to stations transmitting in the 1710–1755 MHz and 2110–2155 MHz bands: Fixed, mobile, and portable (hand-held) stations operating in the 1710–1755 MHz band are limited to 1 watt EIRP.

#### **TEST PROCEDURE**

ANSI/TIA-603-E Clause 2.2.17

KDB 971168 v02r01 RF power output using broadband peak and average power meter method.

KDB 971168 D01 Power Meas License Digital Systems v02r01, "Measurement Guidance for Certification of Licensed Digital Transmitters"

#### **MODES TESTED**

- LTE Band 5
- LTE Band 7
- LTE Band 41

#### **RESULTS**

Pass

8.2 LTE BAND 5

Radiated Power (ERP) for Band 5										
Mode	RB/ RB SIZE	Frequ ncy	Result							Conclu sion
			SG Level (dBm)	Cable Loss (dBm)	Anten na Gain (dB)	Corre ction (dB)	Max. EIRP Averag e (dBm)	Max. EIRP Averag e (mW)	Polarizati on Of Max. ERP	
1.4MHz Band QPSK	6/0	824.7	7.19	2.01	19.68	2.15	22.71	186.638	Vertical	Pass
		836.5	7.24	2.01	19.77	2.15	22.85	192.752	Vertical	Pass
		848.3	6.98	2.02	19.82	2.15	22.63	183.231	Vertical	Pass
1.4MHz Band 16 QAM	6/0	824.7	6.35	2.01	19.68	2.15	21.87	153.815	Vertical	Pass
		836.5	6.24	2.01	19.77	2.15	21.85	153.109	Vertical	Pass
		848.3	6.08	2.02	19.82	2.15	21.73	148.936	Vertical	Pass
3.0MHz Band QPSK	15/0	825.5	7.20	2.01	19.70	2.15	22.74	187.932	Vertical	Pass
		836.5	7.20	2.01	19.77	2.15	22.81	190.985	Vertical	Pass
		847.5	6.98	2.02	19.81	2.15	22.62	182.810	Vertical	Pass
3.0MHz Band 16 QAM	15/0	825.5	6.25	2.01	19.70	2.15	21.79	151.008	Vertical	Pass
		836.5	6.20	2.01	19.77	2.15	21.81	151.705	Vertical	Pass
		847.5	6.03	2.02	19.81	2.15	21.67	146.893	Vertical	Pass
5.0MHz Band QPSK	25/0	826.5	7.28	2.01	19.71	2.15	22.83	191.867	Vertical	Pass
		836.5	7.03	2.01	19.77	2.15	22.64	183.654	Vertical	Pass
		846.5	7.17	2.02	19.79	2.15	22.79	190.108	Vertical	Pass
5.0MHz Band 16 QAM	25/0	826.5	6.31	2.01	19.71	2.15	21.86	153.462	Vertical	Pass
		836.5	6.03	2.01	19.77	2.15	21.64	145.881	Vertical	Pass
		846.5	6.11	2.02	19.79	2.15	21.73	148.936	Vertical	Pass
10.0MH z Band QPSK	50/0	829	7.12	2.01	19.73	2.15	22.69	185.780	Vertical	Pass
		836.5	7.23	2.01	19.77	2.15	22.84	192.309	Vertical	Pass
		844	7.15	2.02	19.78	2.15	22.76	188.799	Vertical	Pass
10.0MH z Band 16 QAM	50/0	829	6.29	2.01	19.73	2.15	21.86	153.462	Vertical	Pass
		836.5	6.13	2.01	19.77	2.15	21.74	149.279	Vertical	Pass
		844	6.17	2.02	19.78	2.15	21.78	150.661	Vertical	Pass

Note:

SG Level= Signal generator output

Max. EIRP Average (dBm)= Antenna Gain(dB)+ SG Level (dBm)- Cable Loss(dBm)

Radiated Power (ERP) for Band 5										
Mode	RB/ RB SIZE	Freque ncy	Result							Conclu sion
			SG Level (dBm)	Cable Loss (dBm)	Anten na Gain (dB)	Corre ction (dB)	Max. EIRP Averag e (dBm)	Max. EIRP Averag e (mW)	Polarizati on Of Max. ERP	
1.4MHz Band QPSK	6/0	824.7	6.72	2.01	19.68	2.15	22.24	167.494	Horizontal	Pass
		836.5	6.70	2.01	19.77	2.15	22.31	170.216	Horizontal	Pass
		848.3	6.64	2.02	19.82	2.15	22.29	169.434	Horizontal	Pass
1.4MHz Band 16 QAM	6/0	824.7	5.67	2.01	19.68	2.15	21.19	131.522	Horizontal	Pass
		836.5	5.66	2.01	19.77	2.15	21.27	133.968	Horizontal	Pass
		848.3	5.58	2.02	19.82	2.15	21.23	132.739	Horizontal	Pass
3.0MHz Band QPSK	15/0	825.5	6.72	2.01	19.70	2.15	22.26	168.267	Horizontal	Pass
		836.5	6.74	2.01	19.77	2.15	22.35	171.791	Horizontal	Pass
		847.5	6.64	2.02	19.81	2.15	22.28	169.044	Horizontal	Pass
3.0MHz Band 16 QAM	15/0	825.5	5.67	2.01	19.70	2.15	21.21	132.130	Horizontal	Pass
		836.5	5.74	2.01	19.77	2.15	21.35	136.458	Horizontal	Pass
		847.5	5.64	2.02	19.81	2.15	21.28	134.276	Horizontal	Pass
5.0MHz Band QPSK	25/0	826.5	6.72	2.01	19.71	2.15	22.27	168.655	Horizontal	Pass
		836.5	6.55	2.01	19.77	2.15	22.16	164.437	Horizontal	Pass
		846.5	6.67	2.02	19.79	2.15	22.29	169.434	Horizontal	Pass
5.0MHz Band 16 QAM	25/0	826.5	5.70	2.01	19.71	2.15	21.25	133.352	Horizontal	Pass
		836.5	5.65	2.01	19.77	2.15	21.26	133.660	Horizontal	Pass
		846.5	5.56	2.02	19.79	2.15	21.18	131.220	Horizontal	Pass
10.0MH z Band QPSK	50/0	829	6.64	2.01	19.73	2.15	22.21	166.341	Horizontal	Pass
		836.5	6.67	2.01	19.77	2.15	22.28	169.044	Horizontal	Pass
		844	6.55	2.02	19.78	2.15	22.16	164.437	Horizontal	Pass
10.0MH z Band 16 QAM	50/0	829	5.70	2.01	19.73	2.15	21.27	133.968	Horizontal	Pass
		836.5	5.52	2.01	19.77	2.15	21.13	129.718	Horizontal	Pass
		844	5.53	2.02	19.78	2.15	21.14	130.017	Horizontal	Pass

Note:

SG Level= Signal generator output

Max. EIRP Average (dBm)= Antenna Gain(dB)+ SG Level (dBm)- Cable Loss(dBm)

8.3 LTE BAND 7

Radiated Power (EIRP) for Band 7									
Mode	RB/ RB SIZE	Frequency	Result						Conclusion
			SG Level (dBm )	Cabl e Loss (dBm )	Antenn a Gain (dB)	Max. EIRP Averag e (dBm)	Max. EIRP Averag e (mW)	Polarizati on Of Max. ERP	
5.0MHz Band QPSK	25/0	2502.5	-1.53	4.54	27.75	21.68	147.231	Vertical	Pass
		2535	-1.88	4.69	27.72	21.15	130.317	Vertical	Pass
		2567.5	-1.94	4.71	27.71	21.06	127.644	Vertical	Pass
5.0MHz Band 16 QAM	25/0	2502.5	-2.47	4.54	27.75	20.74	118.577	Vertical	Pass
		2535	-2.81	4.69	27.72	20.22	105.196	Vertical	Pass
		2567.5	-3.02	4.71	27.71	19.98	99.541	Vertical	Pass
10.0MH z Band QPSK	50/0	2505	-1.57	4.55	27.76	21.64	145.881	Vertical	Pass
		2535	-1.89	4.69	27.72	21.14	130.017	Vertical	Pass
		2565	-1.95	4.72	27.70	21.03	126.765	Vertical	Pass
10.0MH z Band 16 QAM	50/0	2505	-2.43	4.55	27.76	20.78	119.674	Vertical	Pass
		2535	-2.77	4.69	27.72	20.26	106.170	Vertical	Pass
		2565	-2.97	4.72	27.70	20.01	100.231	Vertical	Pass
15.0MH z Band QPSK	75/0	2507.5	-1.53	4.55	27.77	21.69	147.571	Vertical	Pass
		2535	-1.86	4.69	27.72	21.17	130.918	Vertical	Pass
		2562.5	-2.04	4.72	27.69	20.93	123.880	Vertical	Pass
15.0MH z Band 16 QAM	75/0	2507.5	-2.67	4.55	27.77	20.55	113.501	Vertical	Pass
		2535	-2.82	4.69	27.72	20.21	104.954	Vertical	Pass
		2562.5	-3.10	4.72	27.69	19.87	97.051	Vertical	Pass
20.0MH z Band QPSK	100/0	2510	-1.50	4.57	27.78	21.71	148.252	Vertical	Pass
		2535	-1.77	4.73	27.72	21.22	132.434	Vertical	Pass
		2560	-1.90	4.75	27.68	21.03	126.765	Vertical	Pass
20.0MH z Band 16 QAM	100/0	2510	-2.52	4.57	27.78	20.69	117.220	Vertical	Pass
		2535	-2.74	4.73	27.72	20.25	105.925	Vertical	Pass
		2560	-2.80	4.75	27.68	20.13	103.039	Vertical	Pass

Note:

SG Level= Signal generator output

Max. EIRP Average (dBm)= Antenna Gain(dB)+ SG Level (dBm)- Cable Loss(dBm)

Radiated Power (EIRP) for Band 7									
Mode	RB/ RB SIZE	Frequency	Result						Conclusion
			SG Level (dBm )	Cabl e Loss (dBm )	Antenn a Gain (dB)	Max. EIRP Averag e (dBm)	Max. EIRP Averag e (mW)	Polarizati on Of Max. ERP	
5.0MHz Band QPSK	25/0	2502.5	-2.06	4.54	27.75	21.15	130.317	Horizontal	Pass
		2535	-2.36	4.69	27.72	20.67	116.681	Horizontal	Pass
		2567.5	-2.65	4.71	27.71	20.35	108.393	Horizontal	Pass
5.0MHz Band 16 QAM	25/0	2502.5	-2.99	4.54	27.75	20.22	105.196	Horizontal	Pass
		2535	-3.34	4.69	27.72	19.69	93.111	Horizontal	Pass
		2567.5	-3.49	4.71	27.71	19.51	89.331	Horizontal	Pass
10.0MH z Band QPSK	50/0	2505	-2.10	4.55	27.76	21.11	129.122	Horizontal	Pass
		2535	-2.40	4.69	27.72	20.63	115.611	Horizontal	Pass
		2565	-2.67	4.72	27.70	20.31	107.399	Horizontal	Pass
10.0MH z Band 16 QAM	50/0	2505	-2.97	4.55	27.76	20.24	105.682	Horizontal	Pass
		2535	-3.37	4.69	27.72	19.66	92.470	Horizontal	Pass
		2565	-3.50	4.72	27.70	19.48	88.716	Horizontal	Pass
15.0MH z Band QPSK	75/0	2507.5	-2.05	4.55	27.77	21.17	130.918	Horizontal	Pass
		2535	-2.40	4.69	27.72	20.63	115.611	Horizontal	Pass
		2562.5	-2.62	4.72	27.69	20.35	108.393	Horizontal	Pass
15.0MH z Band 16 QAM	75/0	2507.5	-3.03	4.55	27.77	20.19	104.472	Horizontal	Pass
		2535	-3.26	4.69	27.72	19.77	94.842	Horizontal	Pass
		2562.5	-3.41	4.72	27.69	19.56	90.365	Horizontal	Pass
20.0MH z Band QPSK	100/ 0	2510	-1.99	4.57	27.78	21.22	132.434	Horizontal	Pass
		2535	-2.26	4.73	27.72	20.73	118.304	Horizontal	Pass
		2560	-2.57	4.75	27.68	20.36	108.643	Horizontal	Pass
20.0MH z Band 16 QAM	100/ 0	2510	-2.83	4.57	27.78	20.38	109.144	Horizontal	Pass
		2535	-3.38	4.73	27.72	19.61	91.411	Horizontal	Pass
		2560	-3.51	4.75	27.68	19.42	87.498	Horizontal	Pass

Note:

SG Level= Signal generator output

Max. EIRP Average (dBm)= Antenna Gain(dB)+ SG Level (dBm)- Cable Loss(dBm)

8.4 LTE BAND 41

Radiated Power (EIRP) for Band 41										
Mode	RB/ RB SIZE	Frequency	Result						Polarizati on Of Max. ERP	Conclusio n
			SG Level (dBm )	Cable Loss (dBm)	Antenn a Gain (dB)	Max. EIRP Avera ge (dBm)	Max. EIRP			
							Average (mW)			
5.0MHz Band QPSK	25/0	2575	-1.35	4.75	27.68	21.58	143.880	Vertical	Pass	
		2593	-1.23	4.75	27.72	21.74	149.279	Vertical	Pass	
		2635	-1.34	4.78	27.78	21.66	146.555	Vertical	Pass	
5.0MHz Band 16 QAM	25/0	2575	-2.29	4.75	27.68	20.64	115.878	Vertical	Pass	
		2593	-2.20	4.75	27.72	20.77	119.399	Vertical	Pass	
		2635	-2.37	4.78	27.78	20.63	115.611	Vertical	Pass	
10.0MH z Band QPSK	50/0	2577.5	-1.38	4.75	27.68	21.55	142.889	Vertical	Pass	
		2593	-1.18	4.75	27.72	21.79	151.008	Vertical	Pass	
		2632.5	-1.39	4.78	27.78	21.61	144.877	Vertical	Pass	
10.0MH z Band 16 QAM	50/0	2577.5	-2.26	4.75	27.68	20.67	116.681	Vertical	Pass	
		2593	-2.16	4.75	27.72	20.81	120.504	Vertical	Pass	
		2632.5	-2.28	4.77	27.78	20.73	118.304	Vertical	Pass	
15.0MH z Band QPSK	75/0	2580	-1.32	4.75	27.68	21.61	144.877	Vertical	Pass	
		2593	-1.18	4.75	27.72	21.79	151.008	Vertical	Pass	
		2630	-1.29	4.78	27.78	21.71	148.252	Vertical	Pass	
15.0MH z Band 16 QAM	75/0	2580	-2.37	4.75	27.68	20.56	113.763	Vertical	Pass	
		2593	-2.13	4.75	27.72	20.84	121.339	Vertical	Pass	
		2630	-2.28	4.77	27.78	20.73	118.304	Vertical	Pass	
20.0MH z Band QPSK	100/ 0	2582.5	-1.39	4.75	27.68	21.54	142.561	Vertical	Pass	
		2593	-1.34	4.75	27.72	21.63	145.546	Vertical	Pass	
		2627.5	-1.43	4.78	27.78	21.57	143.549	Vertical	Pass	
20.0MH z Band 16 QAM	100/ 0	2582.5	-2.44	4.75	27.68	20.49	111.944	Vertical	Pass	
		2593	-2.35	4.75	27.72	20.62	115.345	Vertical	Pass	
		2627.5	-2.44	4.77	27.78	20.57	114.025	Vertical	Pass	

Note:

SG Level= Signal generator output

Max. EIRP Average (dBm)= Antenna Gain(dB)+ SG Level (dBm)- Cable Loss(dBm)

Radiated Power (EIRP) for Band 41									
Mode	RB/ RB SIZE	Frequency	Result						Conclusion
			SG Level (dBm )	Cable Loss (dBm)	Anten na Gain (dB)	Max. EIRP Average (dBm)	Max. EIRP Averag e (mW)	Polarizati on Of Max. ERP	
5.0MHz Band QPSK	25/0	2575	-1.68	4.75	27.68	21.25	133.352	Horizontal	Pass
		2593	-1.63	4.75	27.72	21.34	136.144	Horizontal	Pass
		2635	-1.64	4.78	27.78	21.36	136.773	Horizontal	Pass
5.0MHz Band 16 QAM	25/0	2575	-2.60	4.75	27.68	20.33	107.895	Horizontal	Pass
		2593	-2.56	4.75	27.72	20.41	109.901	Horizontal	Pass
		2635	-2.65	4.78	27.78	20.35	108.393	Horizontal	Pass
10.0MH z Band QPSK	50/0	2577.5	-1.71	4.75	27.68	21.22	132.434	Horizontal	Pass
		2593	-1.62	4.75	27.72	21.35	136.458	Horizontal	Pass
		2632.5	-1.68	4.78	27.78	21.32	135.519	Horizontal	Pass
10.0MH z Band 16 QAM	50/0	2577.5	-2.57	4.75	27.68	20.36	108.643	Horizontal	Pass
		2593	-2.69	4.75	27.72	20.28	106.660	Horizontal	Pass
		2632.5	-2.72	4.77	27.78	20.29	106.905	Horizontal	Pass
15.0MH z Band QPSK	75/0	2580	-1.67	4.75	27.68	21.26	133.660	Horizontal	Pass
		2593	-1.63	4.75	27.72	21.34	136.144	Horizontal	Pass
		2630	-1.72	4.78	27.78	21.28	134.276	Horizontal	Pass
15.0MH z Band 16 QAM	75/0	2580	-2.59	4.75	27.68	20.34	108.143	Horizontal	Pass
		2593	-2.60	4.75	27.72	20.37	108.893	Horizontal	Pass
		2630	-2.66	4.77	27.78	20.35	108.393	Horizontal	Pass
20.0MH z Band QPSK	100/ 0	2582.5	-1.72	4.75	27.68	21.21	132.130	Horizontal	Pass
		2593	-1.61	4.75	27.72	21.36	136.773	Horizontal	Pass
		2627.5	-1.71	4.78	27.78	21.29	134.586	Horizontal	Pass
20.0MH z Band 16 QAM	100/ 0	2582.5	-2.57	4.75	27.68	20.36	108.643	Horizontal	Pass
		2593	-2.56	4.75	27.72	20.41	109.901	Horizontal	Pass
		2627.5	-2.72	4.77	27.78	20.29	106.905	Horizontal	Pass

Note:

SG Level= Signal generator output

Max. EIRP Average (dBm)= Antenna Gain(dB)+ SG Level (dBm)- Cable Loss(dBm)

## 9. SPURIOUS RADIATION EMISSION

### RULE PART(S)

FCC: §2.1053, §22.917 and §27.53

### LIMIT

§22.917 (e): Out of band emissions. The power of any emission outside of the authorized operating frequency ranges must be attenuated below the transmitting power (P) by a factor of at least  $43 + 10 \log(P)$  dB.

§27.53 (g) For operations in the 698–746 MHz band, the power of any emission outside a licensee's frequency band(s) of operation shall be attenuated below the transmitter power (P) within the licensed band(s) of operation, measured in watts, by at least  $43 + 10 \log(P)$  dB.

§27.53 (h) For operations in the 1710–1755 MHz and 2110–2155 MHz bands, the power of any emission outside a licensee's frequency block shall be attenuated below the transmitter power (P) by at least  $43 + 10 \log_{10}(P)$  dB.

### TEST PROCEDURE

For Cellular equipment - Compliance with these rules is based on the use of measurement instrumentation employing a resolution bandwidth of 100 kHz or greater. In the 1 MHz bands immediately outside and adjacent to the frequency block a resolution bandwidth of at least one percent of the emission bandwidth of the fundamental emission of the transmitter may be employed. A narrower resolution bandwidth is permitted in all cases to improve measurement accuracy provided the measured power is integrated over the full required measurement bandwidth (i.e. 100 kHz or 1 percent of emission bandwidth, as specified). The emission bandwidth is defined as the width of the signal between two points, one below the carrier center frequency and one above the carrier center frequency, outside of which all emissions are attenuated at least 26 dB below the transmitter power.

For PCS equipment - Compliance with these rules is based on the use of measurement instrumentation employing a resolution bandwidth of 1 MHz or greater. However, in the 1 MHz bands immediately outside and adjacent to the frequency block a resolution bandwidth of at least one percent of the emission bandwidth of the fundamental emission of the transmitter may be employed. A narrower resolution bandwidth is permitted in all cases to improve measurement accuracy provided the measured power is integrated over the full required measurement bandwidth ( i.e. 1 MHz or 1 percent of emission bandwidth, as specified). The emission bandwidth is defined as the width of the signal between two points, one below the carrier center frequency and one above the carrier center frequency, outside of which all emissions are attenuated at least 26 dB below the transmitter power.

The unwanted emission power shall be measured with a resolution bandwidth of at least 1% of the occupied bandwidth in the 1 MHz band immediately outside and adjacent to the channel edge of the equipment. Beyond the 1 MHz band immediately outside the channel edge of the equipment, a resolution bandwidth of 1 MHz shall be employed. A narrower resolution bandwidth is allowed to be used provided that the measured power is integrated over the full required measurement bandwidth of 1 MHz or 1% of the occupied bandwidth as applicable.

The power of any unwanted emissions measured from the channel edge of the equipment shall be attenuated below the transmitter power,  $P$  (dBW), as follows:

- a. for base station and subscriber equipment, other than mobile subscriber equipment, the attenuation shall not be less than  $43 + 10 \text{ Log}_{10}(p)$ , dB; and
- b. for mobile subscriber equipment, the attenuation shall not be less than  $43 + 10 \text{ Log}_{10}(p)$ , dB at the channel edges and  $55 + 10 \text{ Log}_{10}(p)$  at 5.5 MHz away and beyond the channel edges where  $p$  in (a) and (b) is the transmitter power measured in watts.

**MODES TESTED**

- LTE Band 5
- LTE Band 7
- LTE Band 41

**RESULTS**

PASS

9.1 LTE BAND 5

**QPSK EIRP POWER FOR LTE BAND 5 (1.4MHZ BANDWIDTH)**

Test Results for Low Channel 824.7MHz							
Frequency(MHz)	SG Level(dBm)	Cable Loss(dB)	Antenna Gain(dB)	Absolute Level(dBm)	Limit (dBm)	Margin(dBm)	Polarity
1649.4	-56.96	2.78	27.50	-32.24	-13	-19.24	Horizontal
1649.4	-58.43	2.78	27.50	-33.71	-13	-20.71	Vertical
2474.1	-53.64	2.90	27.80	-28.74	-13	-15.74	Vertical
2474.1	-57.41	2.90	27.80	-32.51	-13	-19.51	Horizontal
Test Results For Mid Channel 836.5MHz							
1673	-55.28	2.78	27.48	-30.58	-13	-17.58	Horizontal
1673	-54.41	2.78	27.48	-29.71	-13	-16.71	Vertical
2509.5	-55.56	2.91	27.70	-30.77	-13	-17.77	Vertical
2509.5	-57.98	2.91	27.70	-33.19	-13	-20.19	Horizontal
Test Results for High Channel 848.3MHz							
1696.6	-54.41	2.78	27.43	-29.76	-13	-16.76	Horizontal
1696.6	-58.87	2.78	27.43	-34.22	-13	-21.22	Vertical
2544.9	-54.96	2.92	27.74	-30.14	-13	-17.14	Vertical
2544.9	-55.56	2.92	27.74	-30.74	-13	-17.74	Horizontal

**QPSK EIRP POWER FOR LTE BAND 5 (10MHZ BANDWIDTH)**

Test Results for Low Channel 829MHz							
Frequency(MHz)	SG Level(dBm)	Cable Loss(dB)	Antenna Gain(dB)	Absolute Level(dBm)	Limit (dBm)	Margin(dBm)	Polarity
1658	-56.96	2.78	27.50	-32.24	-13	-19.24	Horizontal
1658	-55.57	2.78	27.50	-30.85	-13	-17.85	Vertical
2487	-57.84	2.90	27.80	-32.94	-13	-19.94	Vertical
2487	-57.41	2.90	27.80	-32.51	-13	-19.51	Horizontal
Test Results For Mid Channel 836.5MHz							
1673	-57.85	2.78	27.48	-33.15	-13	-20.15	Horizontal
1673	-59.96	2.78	27.48	-35.26	-13	-22.26	Vertical
2509.5	-56.32	2.91	27.70	-31.53	-13	-18.53	Vertical
2509.5	-55.24	2.91	27.70	-30.45	-13	-17.45	Horizontal
Test Results for High Channel 844MHz							
1688	-55.54	2.78	27.43	-30.89	-13	-17.89	Horizontal
1688	-54.41	2.78	27.43	-29.76	-13	-16.76	Vertical
2532	-53.62	2.92	27.74	-28.80	-13	-15.80	Vertical
2532	-52.81	2.92	27.74	-27.99	-13	-14.99	Horizontal

Note: P<sub>Mea</sub>(dBm)= Power(dBm)+ ARpl (dBm)

Over Limit= : P<sub>Mea</sub>(dBm)-Limit(dBm)

We test both H direction and V direction, recorded worst case direction.

9.2 LTE BAND 7

**QPSK EIRP POWER FOR LTE BAND 7 (5.0MHZ BANDWIDTH)**

Test Results for Low Channel 2502.5MHz							
Frequency(MHz)	SG Level(dBm)	Cable Loss(dB)	Antenna Gain(dB)	Absolute Level(dBm)	Limit (dBm)	Margin(dBm)	Polarity
5005	-59.85	5.23	35.81	-29.27	-13	-16.27	Horizontal
5005	-55.64	5.23	35.81	-25.06	-13	-12.06	Vertical
7507.5	-57.84	5.67	36.85	-26.66	-13	-13.66	Vertical
7507.5	-57.41	5.67	36.85	-26.23	-13	-13.23	Horizontal
Test Results for Mid Channel 2535MHz							
5070	-56.63	5.23	35.82	-26.04	-13	-13.04	Horizontal
5070	-58.94	5.23	35.82	-28.35	-13	-15.35	Vertical
7605	-57.94	5.67	36.85	-26.76	-13	-13.76	Vertical
7605	-59.41	5.67	36.85	-28.23	-13	-15.23	Horizontal
Test Results for High Channel 2567.5MHz							
5135	-56.62	5.24	35.83	-26.03	-13	-13.03	Horizontal
5135	-55.52	5.24	35.83	-24.93	-13	-11.93	Vertical
7702.5	-58.23	5.68	36.87	-27.04	-13	-14.04	Vertical
7702.5	-58.41	5.68	36.87	-27.22	-13	-14.22	Horizontal

**QPSK EIRP POWER FOR LTE BAND 7 (20.0MHZ BANDWIDTH)**

Test Results for Low Channel 2510MHz							
Frequency(MHz)	SG Level(dBm)	Cable Loss(dB)	Antenna Gain(dB)	Absolute Level(dBm)	Limit (dBm)	Margin(dBm)	Polarity
5020	-59.68	5.23	35.82	-29.09	-13	-16.09	Horizontal
5020	-59.45	5.23	35.82	-28.86	-13	-15.86	Vertical
7530	-60.21	5.67	36.86	-29.02	-13	-16.02	Vertical
7530	-56.63	5.67	36.86	-25.44	-13	-12.44	Horizontal
Test Results for Mid Channel 2535MHz							
5070	-57.84	5.23	35.82	-27.25	-13	-14.25	Horizontal
5070	-55.58	5.23	35.82	-24.99	-13	-11.99	Vertical
7605	-59.96	5.67	36.85	-28.78	-13	-15.78	Vertical
7605	-58.42	5.67	36.85	-27.24	-13	-14.24	Horizontal
Test Results for High Channel 2560MHz							
5120	-54.41	5.24	35.83	-23.82	-13	-10.82	Horizontal
5120	-56.66	5.24	35.83	-26.07	-13	-13.07	Vertical
7680	-58.61	5.70	36.88	-27.43	-13	-14.43	Vertical
7680	-60.32	5.70	36.88	-29.14	-13	-16.14	Horizontal

Note: P<sub>Mea</sub>(dBm)= Power(dBm)+ ARpl (dBm)  
 Over Limit= : P<sub>Mea</sub>(dBm)-Limit(dBm)  
 We test both H direction and V direction, recorded worst case direction.

9.3 LTE BAND 41

**QPSK EIRP POWER FOR LTE BAND 41 (5MHZ BANDWIDTH)**

Test Results for Low Channel 2575MHz							
Frequency(MHz)	SG Level(dBm)	Cable Loss(dB)	Antenna Gain(dB)	Absolute Level(dBm)	Limit (dBm)	Margin(dBm)	Polarity
5150.0	-56.41	5.28	35.81	-25.88	-13	-12.88	Horizontal
5150.0	-58.64	5.28	35.81	-28.11	-13	-15.11	Vertical
7725.0	-57.61	5.74	36.85	-26.50	-13	-13.50	Vertical
7725.0	-57.36	5.74	36.85	-26.25	-13	-13.25	Horizontal
Test Results for Mid Channel 2593MHz							
5186.0	-57.44	5.28	35.82	-26.90	-13	-13.90	Horizontal
5186.0	-56.95	5.28	35.82	-26.41	-13	-13.41	Vertical
7779.0	-58.89	5.78	36.85	-27.82	-13	-14.82	Vertical
7779.0	-59.13	5.78	36.85	-28.06	-13	-15.06	Horizontal
Test Results for High Channel 2635MHz							
5270.0	-58.62	5.31	35.83	-28.10	-13	-15.10	Horizontal
5270.0	-57.52	5.31	35.83	-27.00	-13	-14.00	Vertical
7905.0	-58.46	5.80	36.87	-27.39	-13	-14.39	Vertical
7905.0	-58.63	5.80	36.87	-27.56	-13	-14.56	Horizontal

**QPSK EIRP POWER FOR LTE BAND 41 (20.0MHZ BANDWIDTH)**

<b>Test Results for Low Channel 2582.5MHz</b>							
Frequency(MHz)	SG Level(dBm)	Cable Loss(dB)	Antenna Gain(dB)	Absolute Level(dBm)	Limit (dBm)	Margin(dBm)	Polarity
5165.0	-57.47	5.28	35.82	-26.93	-13	-13.93	Horizontal
5165.0	-58.95	5.28	35.82	-28.41	-13	-15.41	Vertical
7747.5	-58.65	5.76	36.86	-27.55	-13	-14.55	Vertical
7747.5	-58.93	5.76	36.86	-27.83	-13	-14.83	Horizontal
<b>Test Results for Mid Channel 2593MHz</b>							
5186.0	-54.41	5.28	35.82	-23.87	-13	-10.87	Horizontal
5186.0	-56.62	5.28	35.82	-26.08	-13	-13.08	Vertical
7779.0	-57.82	5.78	36.85	-26.75	-13	-13.75	Vertical
7779.0	-57.94	5.78	36.85	-26.87	-13	-13.87	Horizontal
<b>Test Results for High Channel 2627.5MHz</b>							
5255.0	-58.13	5.30	35.83	-27.60	-13	-14.60	Horizontal
5255.0	-58.52	5.30	35.83	-27.99	-13	-14.99	Vertical
7882.5	-59.65	5.80	36.88	-28.57	-13	-15.57	Vertical
7882.5	-57.84	5.80	36.88	-26.76	-13	-13.76	Horizontal

Note:  $P_{Mea}(dBm) = Power(dBm) + ARpl (dBm)$

. Over Limit =  $P_{Mea}(dBm) - Limit(dBm)$

. We test both H direction and V direction, recorded worst case direction.

## 10. FREQUENCY STABILITY

### RULE PART(S)

FCC: §2.1055, §22.355, §27.54

### LIMITS

§22.355 - The carrier frequency shall not depart from the reference frequency in excess of  $\pm 2.5$  ppm for mobile stations.

### TEST PROCEDURE

Use CMW 500 with Frequency Error measurement capability.

- Temp. =  $-30^{\circ}$  to  $+50^{\circ}\text{C}$
- Voltage = low voltage, DC 6.3V, Normal, DC 7.4V and High voltage, DC DC 8.5V.

### Frequency Stability vs Temperature:

The EUT is placed inside a temperature chamber. The temperature is set to  $-30^{\circ}\text{C}$  and allowed to stabilize. After sufficient soak time, the transmitting frequency error is measured. The temperature is increased by 10 degrees, allowed to stabilize and soak, and then the measurement is repeated. This is repeated until  $+50^{\circ}\text{C}$  is reached.

### Frequency Stability vs Voltage:

The peak frequency error is recorded (worst-case).

### MODES TESTED

- LTE Band 5
- LTE Band 7
- LTE Band 41

### RESULTS

See the following pages.

10.1 LTE BAND 5

QPSK, (10MHz BANDWIDTH)

**Frequency error vs. Voltage**

Voltage [Vdc]	Frequency [MHz]	Frequency* Error[Hz]	Frequency Error[ppm]	Limit [ppm]
<b>BAND 5 QPSK, (CH 20525 RB size 50 RB Offset 0 10MHz BANDWIDTH)</b>				
6.3	836.5	-2.6	-0.003108	2.5
7.4	836.5	-5.7	-0.006814	2.5
8.5	836.5	-6.3	-0.007531	2.5

**Frequency error vs. Temperature**

Temperature [° C]	Frequency [MHz]	Frequency* Error[Hz]	Frequency Error[ppm]	Limit [ppm]
<b>BAND 5 QPSK, (CH 20525 RB size 50 RB Offset 0 10MHz BANDWIDTH)</b>				
Normal (25C)	836.5	-2.8	-0.003347	2.5
Extreme (50C)	836.5	4.1	0.004901	2.5
Extreme (40C)	836.5	3.9	0.004662	2.5
Extreme (30C)	836.5	6.5	0.007770	2.5
Extreme (10C)	836.5	-7.4	-0.008846	2.5
Extreme (0C)	836.5	-6.4	-0.007651	2.5
Extreme (-10C)	836.5	-6.2	-0.007412	2.5
Extreme (-20C)	836.5	-5.8	-0.006934	2.5
Extreme (-30C)	836.5	-5.3	-0.006336	2.5

**16QAM, (10MHz BANDWIDTH)**

**Frequency error vs. Voltage**

Voltage [Vdc]	Frequency [MHz]	Frequency* Error[Hz]	Frequency Error[ppm]	Limit [ppm]
<b>BAND 5 16QAM, (CH 20525 RB size 50 RB Offset 0 10MHz BANDWIDTH)</b>				
6.3	836.5	-3.6	-0.004304	2.5
7.4	836.5	-4.4	-0.005260	2.5
8.5	836.5	-3.2	-0.003825	2.5

**Frequency error vs. Temperature**

Temperature [° C]	Frequency [MHz]	Frequency* Error[Hz]	Frequency Error[ppm]	Limit [ppm]
<b>BAND 5 16QAM, (CH 20525 RB size 50 RB Offset 0 10MHz BANDWIDTH)</b>				
Normal (25C)	836.5	-4.7	-0.005619	2.5
Extreme (50C)	836.5	-6.3	-0.007531	2.5
Extreme (40C)	836.5	5.2	0.006216	2.5
Extreme (30C)	836.5	4.1	0.004901	2.5
Extreme (10C)	836.5	4.3	0.005140	2.5
Extreme (0C)	836.5	6.9	0.008249	2.5
Extreme (-10C)	836.5	2.8	0.003347	2.5
Extreme (-20C)	836.5	3.3	0.003945	2.5
Extreme (-30C)	836.5	3.6	0.004304	2.5

**\*Note:** Frequency error measurements were made by using the build-in capability of the Wireless Communication Test Set.

10.2 LTE BAND 7

QPSK, (20MHz BANDWIDTH)

**Frequency error vs. Voltage**

Voltage [Vdc]	Frequency [MHz]	Frequency* Error[Hz]	Frequency Error[ppm]	Limit [ppm]
<b>BAND 7 QPSK, (CH 21100 RB size 100 RB Offset 0 20MHz BANDWIDTH)</b>				
6.3	2535	8	0.003156	2.5
7.4	2535	13	0.005128	2.5
8.5	2535	11	0.004339	2.5

**Frequency error vs. Temperature**

Temperature [° C]	Frequency [MHz]	Frequency* Error[Hz]	Frequency Error[ppm]	Limit [ppm]
<b>BAND 7 QPSK, (CH 21100 RB size 100 RB Offset 0 20MHz BANDWIDTH)</b>				
Normal (25C)	2535	9	0.003550	2.5
Extreme (50C)	2535	10.4	0.004103	2.5
Extreme (40C)	2535	8.8	0.003471	2.5
Extreme (30C)	2535	9.6	0.003787	2.5
Extreme (10C)	2535	9.1	0.003590	2.5
Extreme (0C)	2535	12.3	0.004852	2.5
Extreme (-10C)	2535	12.1	0.004773	2.5
Extreme (-20C)	2535	11.7	0.004615	2.5
Extreme (-30C)	2535	11.1	0.004379	2.5

**16QAM, (20MHz BANDWIDTH)**

**Frequency error vs. Voltage**

Voltage [Vdc]	Frequency [MHz]	Frequency* Error[Hz]	Frequency Error[ppm]	Limit [ppm]
<b>BAND 7 16QAM, (CH 21100 RB size 100 RB Offset 0 20MHz BANDWIDTH)</b>				
6.3	2535	7.7	0.003037	2.5
7.4	2535	6.3	0.002485	2.5
8.5	2535	14.8	0.005838	2.5

**Frequency error vs. Temperature**

Temperature [° C]	Frequency [MHz]	Frequency* Error[Hz]	Frequency Error[ppm]	Limit [ppm]
<b>BAND 7 16QAM, (CH 21100 RB size 100 RB Offset 0 20MHz BANDWIDTH)</b>				
Normal (25C)	2535	11.2	0.004418	2.5
Extreme (50C)	2535	10.6	0.004181	2.5
Extreme (40C)	2535	10.3	0.004063	2.5
Extreme (30C)	2535	9.8	0.003866	2.5
Extreme (10C)	2535	7.4	0.002919	2.5
Extreme (0C)	2535	7.7	0.003037	2.5
Extreme (-10C)	2535	6.9	0.002722	2.5
Extreme (-20C)	2535	6.4	0.002525	2.5
Extreme (-30C)	2535	7.9	0.003116	2.5

**\*Note:** Frequency error measurements were made by using the build-in capability of the Wireless Communication Test Set.

10.3 LTE BAND 41

QPSK, (20MHz BANDWIDTH)

**Frequency error vs. Voltage**

Voltage [Vdc]	Frequency [MHz]	Frequency* Error[Hz]	Frequency Error[ppm]	Limit [ppm]
<b>QPSK, (CH 40620 RB size 100 RB Offset 0 20MHz BANDWIDTH)</b>				
6.3	2593	-13.6	-0.005245	2.5
7.4	2593	-13.5	-0.005206	2.5
8.5	2593	-11.4	-0.004396	2.5

**Frequency error vs. Temperature**

Temperature [° C]	Frequency [MHz]	Frequency* Error[Hz]	Frequency Error[ppm]	Limit [ppm]
<b>QPSK, (CH 40620 RB size 100 RB Offset 0 20MHz BANDWIDTH)</b>				
Normal (25C)	2593	10.8	0.004165	2.5
Extreme (50C)	2593	14.5	0.005592	2.5
Extreme (40C)	2593	-16.4	-0.006325	2.5
Extreme (30C)	2593	-14.7	-0.005669	2.5
Extreme (10C)	2593	-15.8	-0.006093	2.5
Extreme (0C)	2593	12.5	0.004821	2.5
Extreme (-10C)	2593	15	0.005785	2.5
Extreme (-20C)	2593	18	0.006942	2.5
Extreme (-30C)	2593	17.6	0.006788	2.5

**16QAM, (20MHz BANDWIDTH)**

**Frequency error vs. Voltage**

Voltage [Vdc]	Frequency [MHz]	Frequency* Error[Hz]	Frequency Error[ppm]	Limit [ppm]
<b>16QAM, (CH 40620 RB size 100 RB Offset 0 20MHz BANDWIDTH)</b>				
6.3	2593	-13.1	-0.005052	2.5
7.4	2593	-18.2	-0.007019	2.5
8.5	2593	-17.4	-0.006710	2.5

**Frequency error vs. Temperature**

Temperature [° C]	Frequency [MHz]	Frequency* Error[Hz]	Frequency Error[ppm]	Limit [ppm]
<b>16QAM, (CH 40620 RB size 100 RB Offset 0 20MHz BANDWIDTH)</b>				
Normal (25C)	2593	11.5	0.004435	2.5
Extreme (50C)	2593	-16.4	-0.006325	2.5
Extreme (40C)	2593	-15.3	-0.005901	2.5
Extreme (30C)	2593	-14.7	-0.005669	2.5
Extreme (10C)	2593	11.3	0.004358	2.5
Extreme (0C)	2593	12.5	0.004821	2.5
Extreme (-10C)	2593	10.8	0.004165	2.5
Extreme (-20C)	2593	-10.9	-0.004204	2.5
Extreme (-30C)	2593	-11.1	-0.004281	2.5

**\*Note:** Frequency error measurements were made by using the build-in capability of the Wireless Communication Test Set.

## 11. Peak-to-Average Ratio

### 11.1 Description of the PAR Measurement

The peak-to-average ratio (PAR) of the transmission may not exceed 13 dB.

### 11.2 Measuring Instruments

See list of measuring instruments of this test report.

### 11.3 Test Procedures

1. The EUT was connected to Spectrum Analyzer and Base Station via power divider.
2. The RF output of EUT was connected to the spectrum analyzer by RF cable and attenuator. The path loss was compensated to the results for each measurement.
3. For GSM/EGPRS operating modes:
  - a. Set the RBW = 1MHz, VBW = 1MHz, Peak detector in spectrum analyzer.
  - b. Set EUT in maximum power output, and triggered the burst signal.
  - c. Measured respectively the Peak level and Mean level, and the deviation was recorded as Peak to Average Ratio.
4. For UMTS operating modes:
  - a. Set the CCDF (Complementary Cumulative Distribution Function) option in spectrum analyzer.
  - b. The highest RF powers were measured and recorded the maximum PAPR level associated with a probability of 0.1 %.

### 11.4 Test Setup

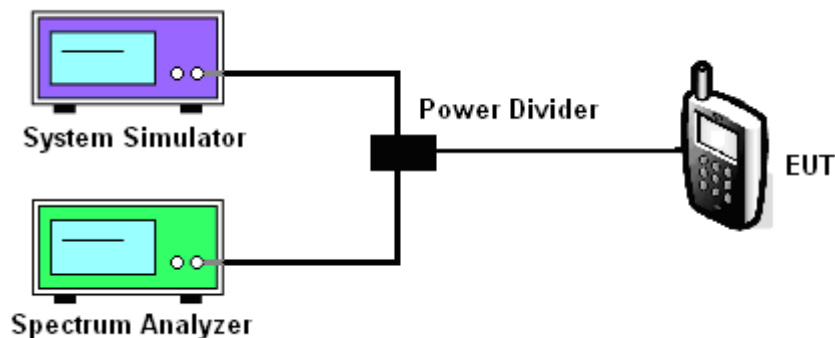

#### MODES TESTED

- LTE Band5
- LTE Band 7
- LTE Band 41

BAND	CHANNEL	Frequency [MHz]	BANDWIDTH	NO. RB	RB POS.	MODULATION	PAR [dB]
5	20525	836.5	1.4	1	Low	QPSK	6.12
5	20525	836.5	1.4	1	Low	16-QAM	6.78
5	20525	836.5	3.0	1	Low	QPSK	6.26
5	20525	836.5	3.0	1	Low	16-QAM	6.83
5	20525	836.5	5.0	1	Low	QPSK	6.27
5	20525	836.5	5.0	1	Low	16-QAM	6.80
5	20525	836.5	10.0	1	Low	QPSK	6.21
5	20525	836.5	10.0	1	Low	16-QAM	6.83
7	21100	2535.0	5.0	1	Low	QPSK	5.27
7	21100	2535.0	5.0	1	Low	16-QAM	5.94
7	21100	2535.0	10.0	1	Low	QPSK	5.21
7	21100	2535.0	10.0	1	Low	16-QAM	5.95
7	21100	2535.0	15.0	1	Low	QPSK	5.57
7	21100	2535.0	15.0	1	Low	16-QAM	6.05
7	21100	2535.0	20.0	1	Low	QPSK	5.30
7	21100	2535.0	20.0	1	Low	16-QAM	6.07
41	40620	2593	5.0	1	Low	QPSK	5.72
41	40620	2593	5.0	1	Low	16-QAM	6.31
41	40620	2593	10.0	1	Low	QPSK	5.65
41	40620	2593	10.0	1	Low	16-QAM	6.38
41	40620	2593	15.0	1	Low	QPSK	5.90
41	40620	2593	15.0	1	Low	16-QAM	6.43
41	40620	2593	20.0	1	Low	QPSK	5.65
41	40620	2593	20.0	1	Low	16-QAM	6.32

11.5 LTE BAND 5

Band 5, UL Channel 20525, UL Frequency 836.5, BW 1.4, NO. RB 1, RB POS. Low, QPSK

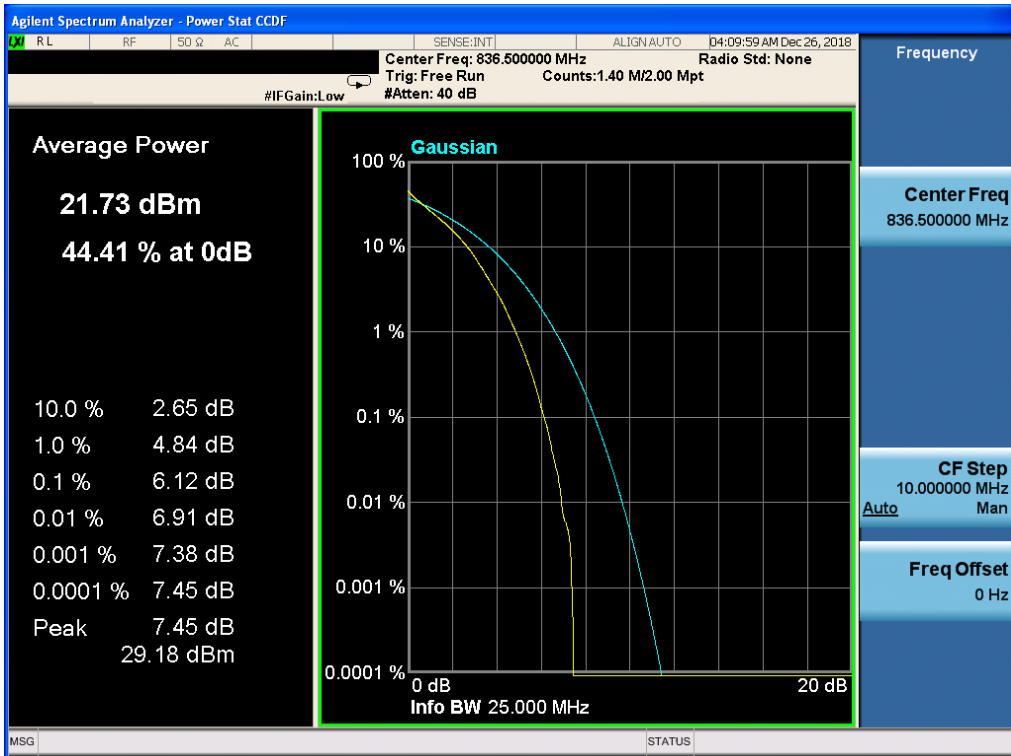

Band 5, UL Channel 20525, UL Frequency 836.5, BW 1.4, NO. RB 1, RB POS. Low, 16-QAM

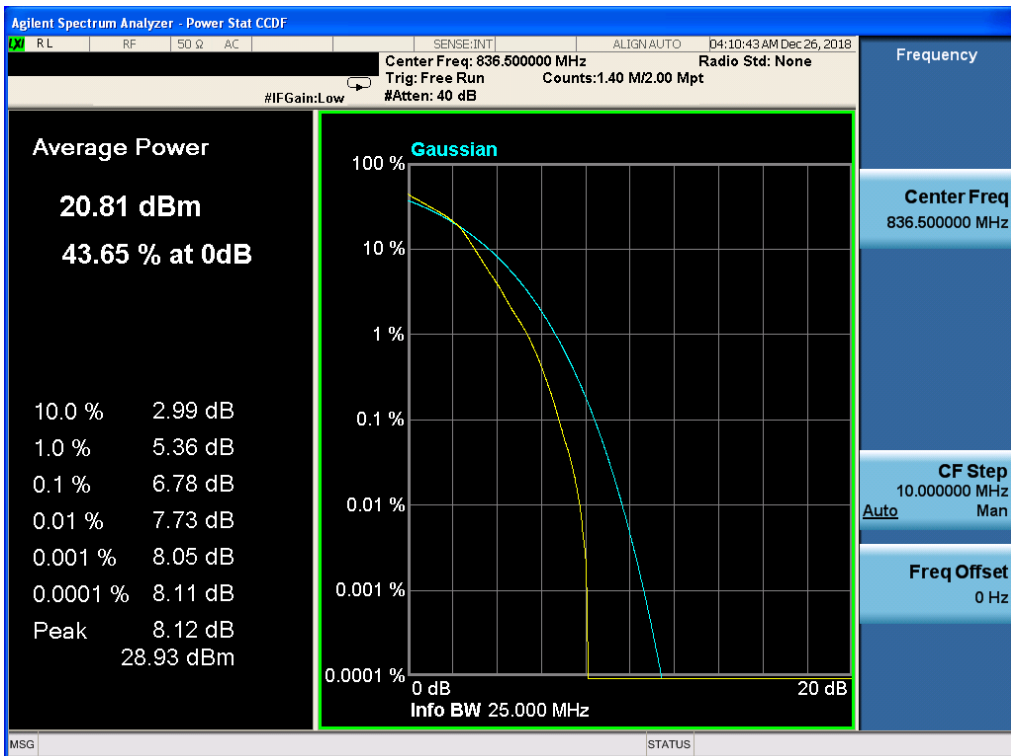

Band 5, UL Channel 20525, UL Frequency 836.5, BW 3.0, NO. RB 1, RB POS. Low, QPSK

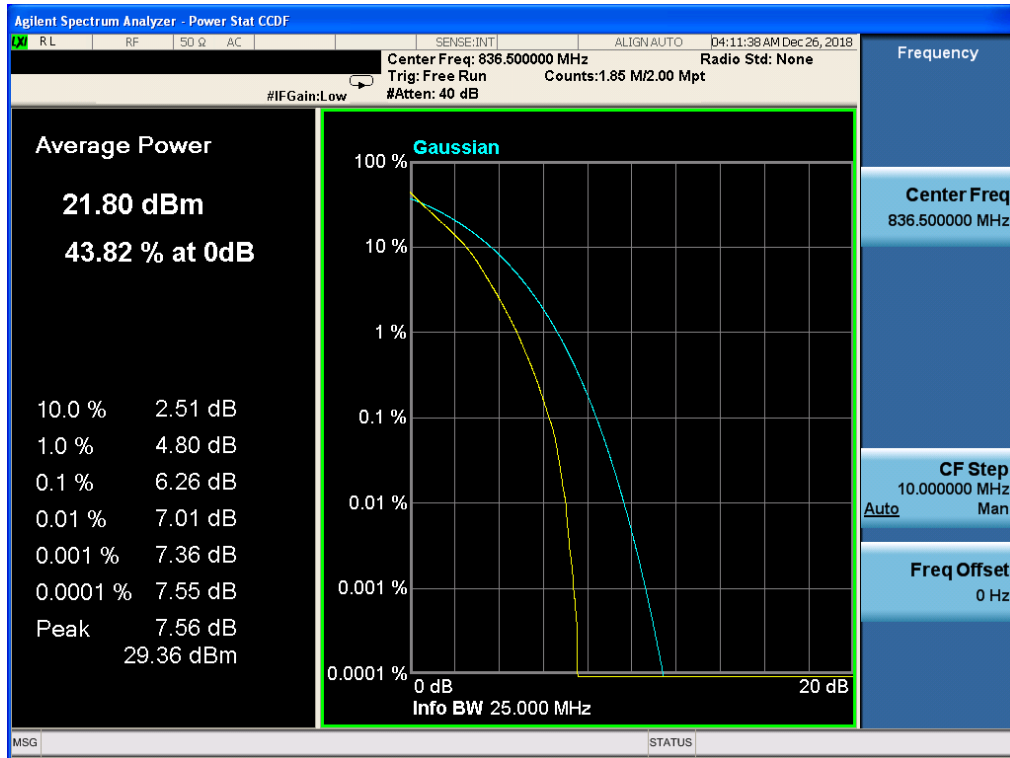

Band 5, UL Channel 20525, UL Frequency 836.5, BW 3.0, NO. RB 1, RB POS. Low, 16-QAM

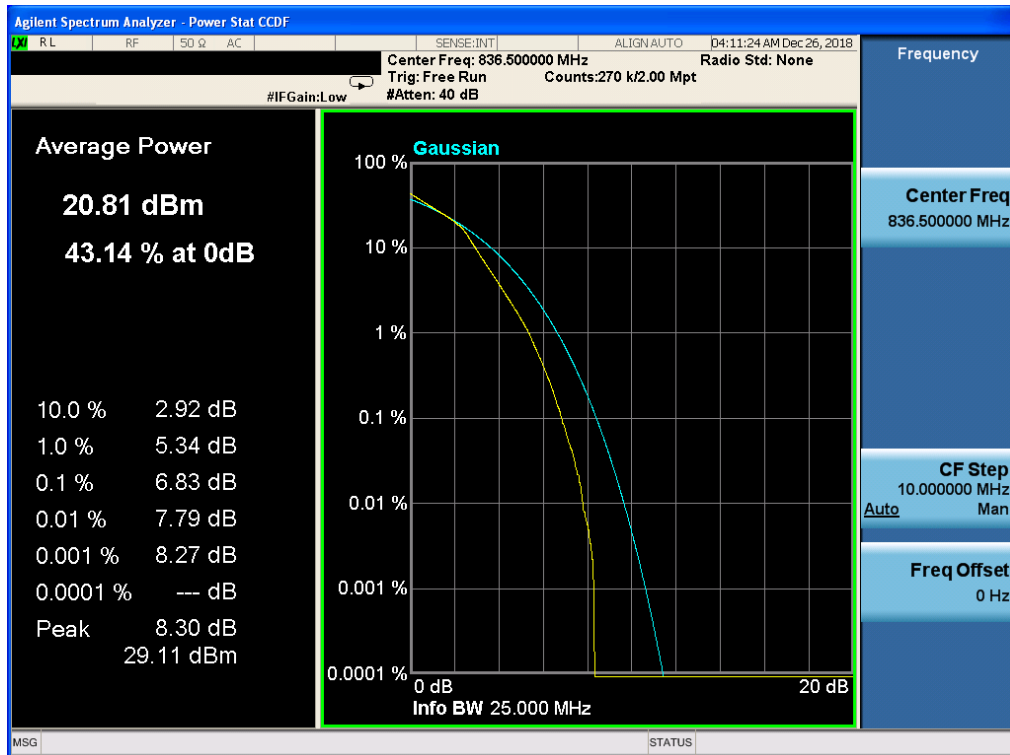

Band 5, UL Channel 20525, UL Frequency 836.5, BW 5.0, NO. RB 1, RB POS. Low, QPSK

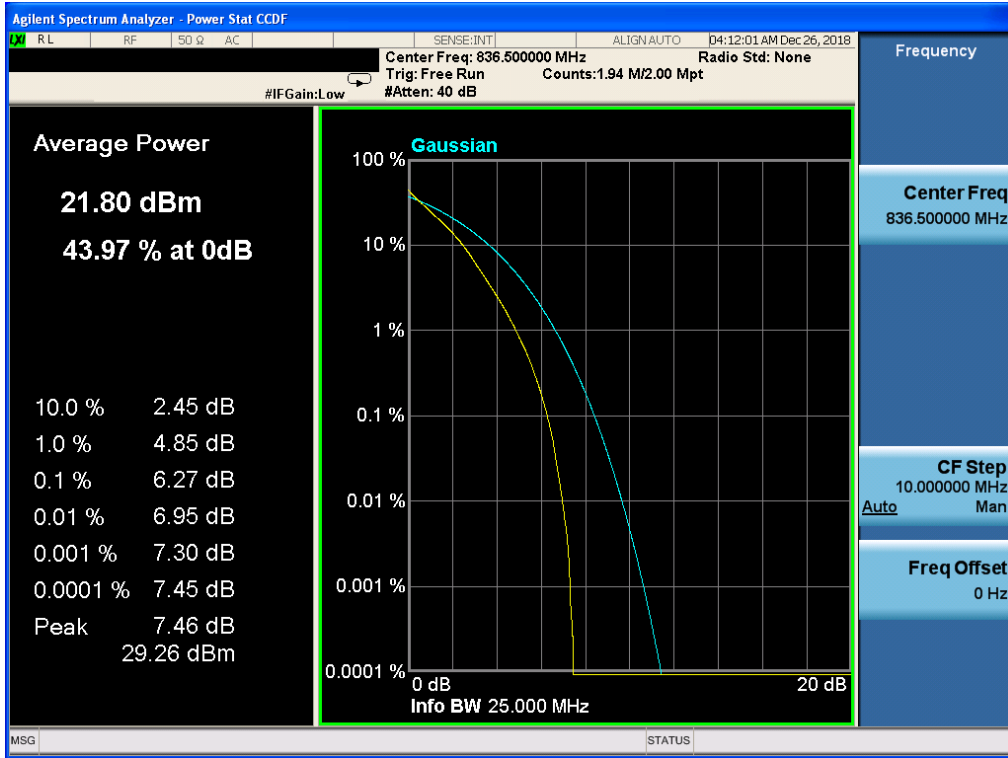

Band 5, UL Channel 20525, UL Frequency 836.5, BW 5.0, NO. RB 1, RB POS. Low, 16-QAM

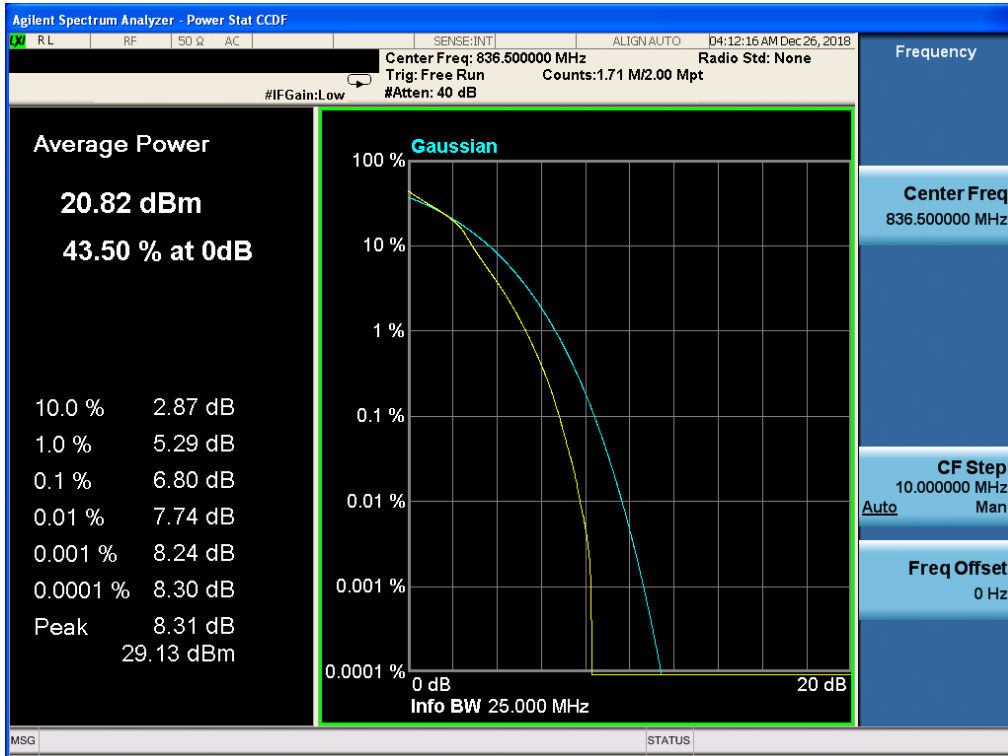

Band 5, UL Channel 20525, UL Frequency 836.5, BW 10.0, NO. RB 1, RB POS. Low, QPSK

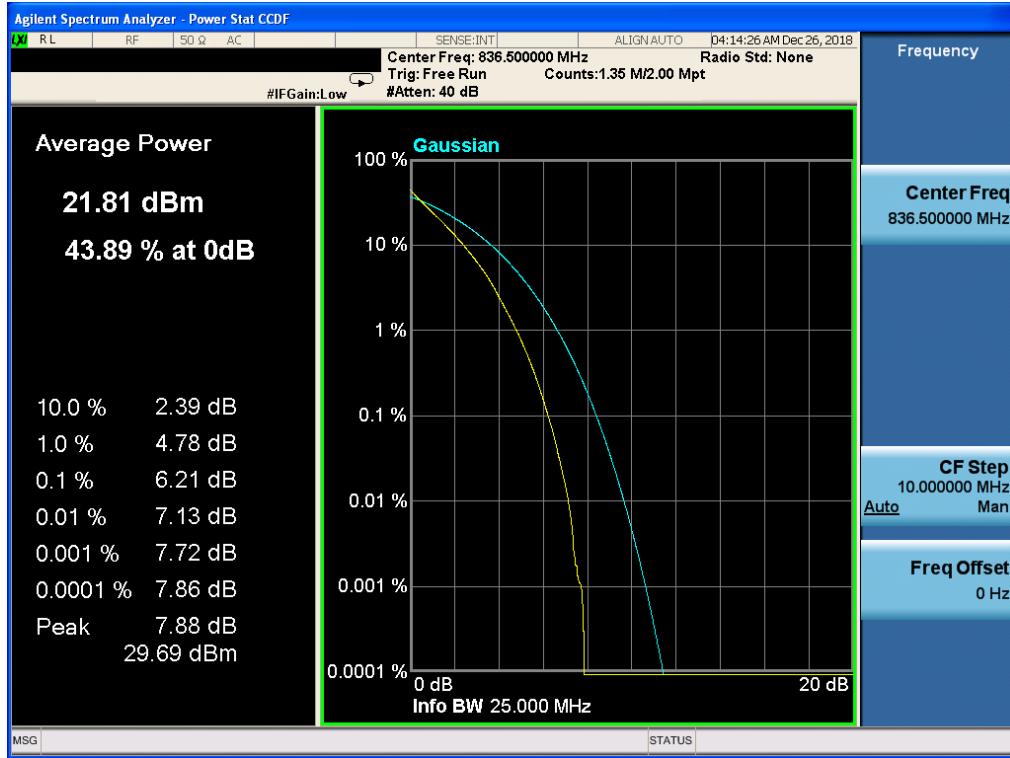

Band 5, UL Channel 20525, UL Frequency 836.5, BW 10.0, NO. RB 1, RB POS. Low, 16-QAM

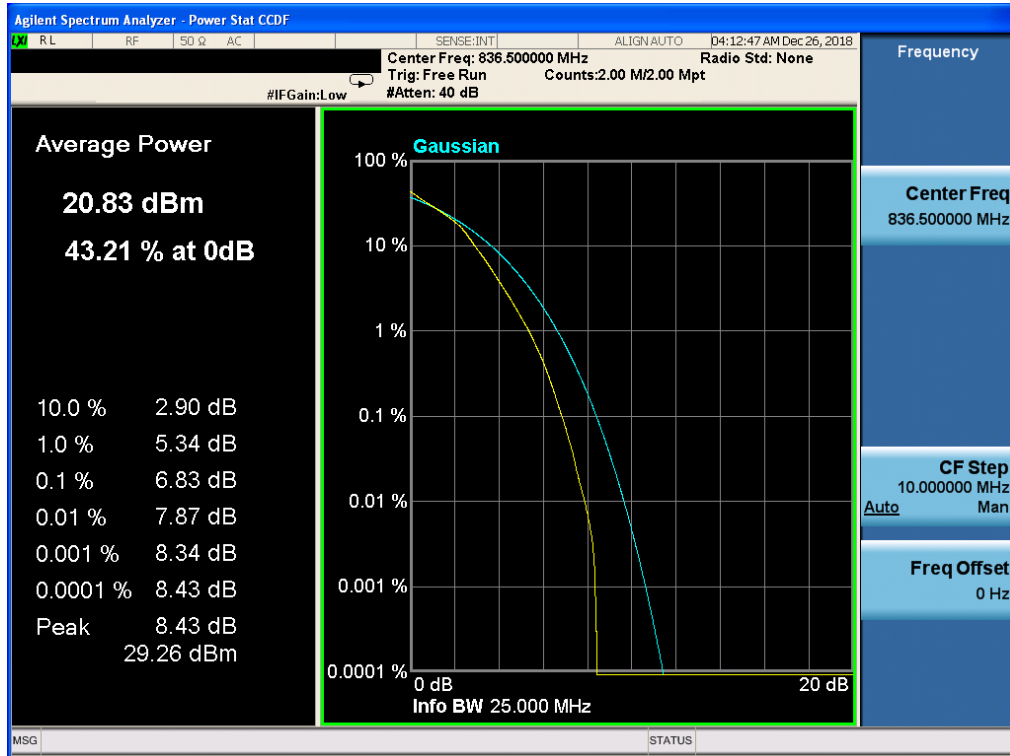

### 11.6 LTE BAND 7

Band 7, UL Channel 21100, UL Frequency 2535.0, BW 5.0, NO. RB 25, RB POS. Low, QPSK

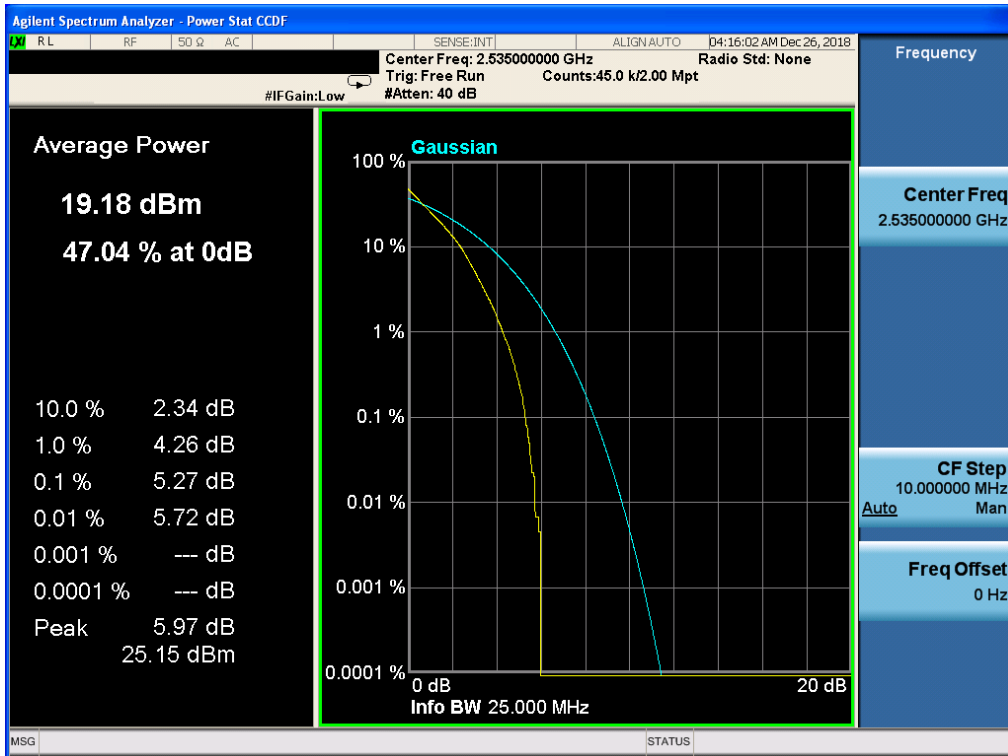

Band 7, UL Channel 21100, UL Frequency 2535.0, BW 5.0, NO. RB 25, RB POS. Low, 16-QAM

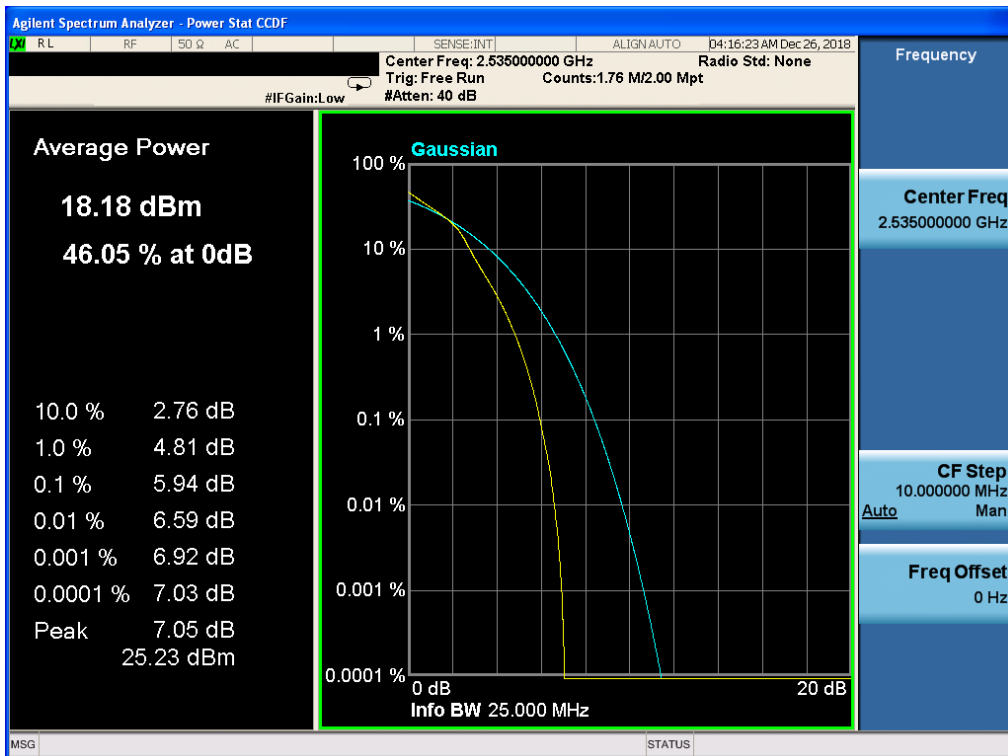

Band 7, UL Channel 21100, UL Frequency 2535.0, BW 10.0, NO. RB 50, RB POS. Low, QPSK

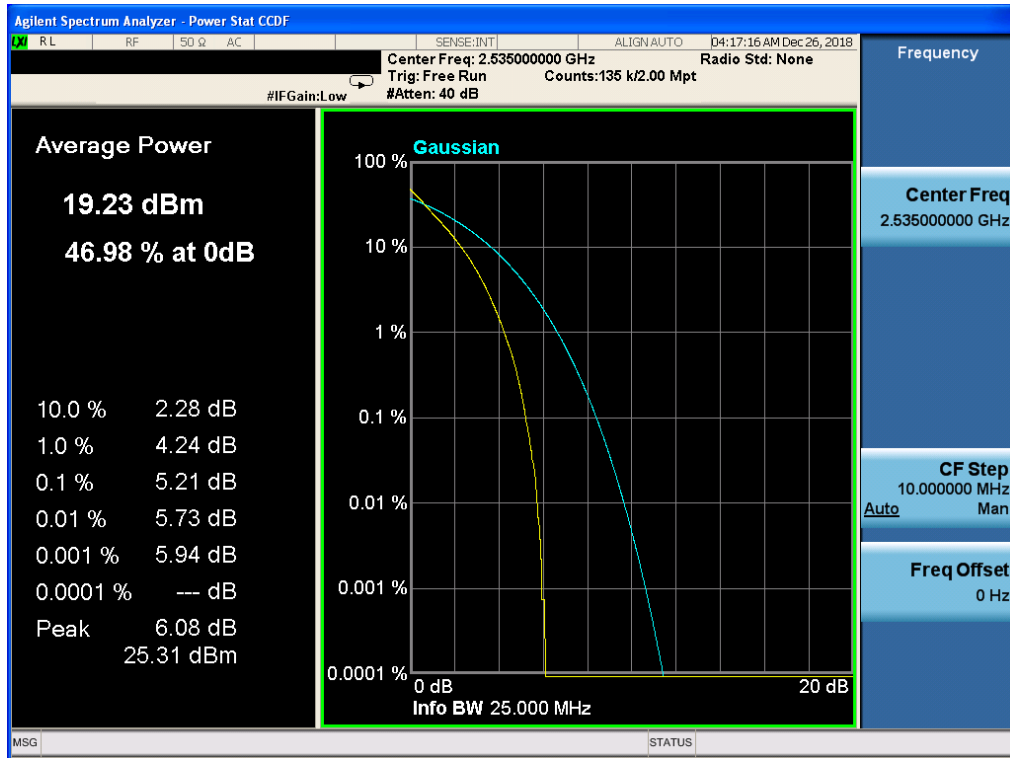

Band 7, UL Channel 21100, UL Frequency 2535.0, BW 10.0, NO. RB 1, RB POS. Low, 16-QAM

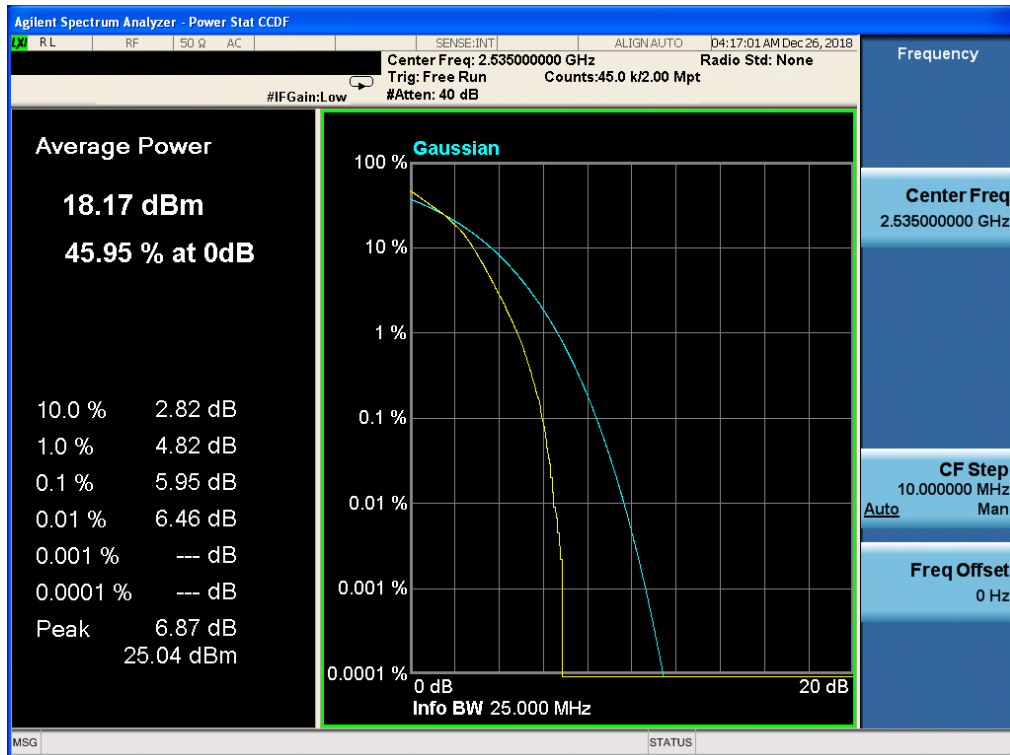

Band 7, UL Channel 21100, UL Frequency 2535.0, BW 15.0, NO. RB 1, RB POS. Low, QPSK

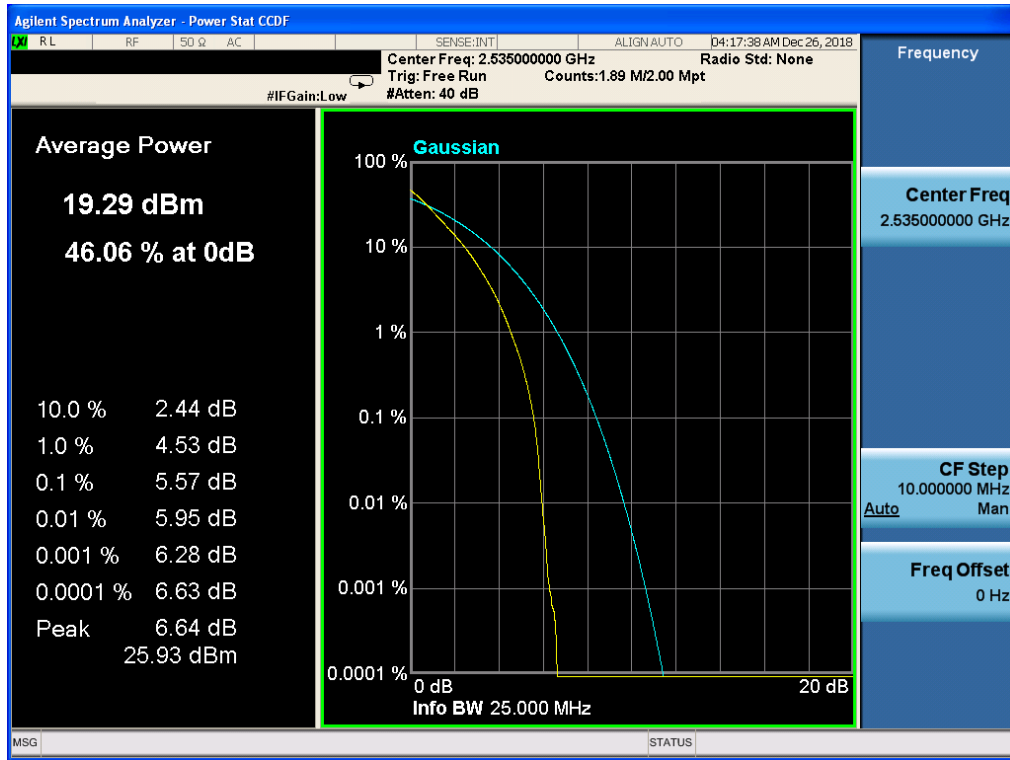

Band 7, UL Channel 21100, UL Frequency 2535.0, BW 15.0, NO. RB 1, RB POS. Low, 16-QAM

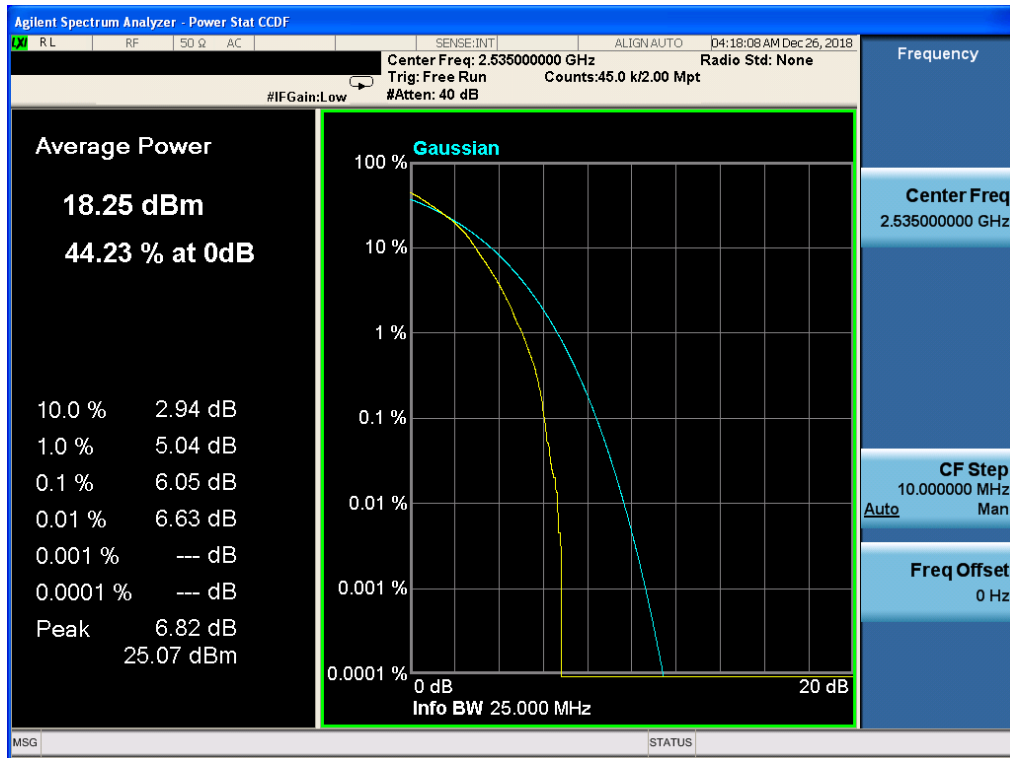

Band 7, UL Channel 21100, UL Frequency 2535.0, BW 20.0, NO. RB 1, RB POS. Low, QPSK

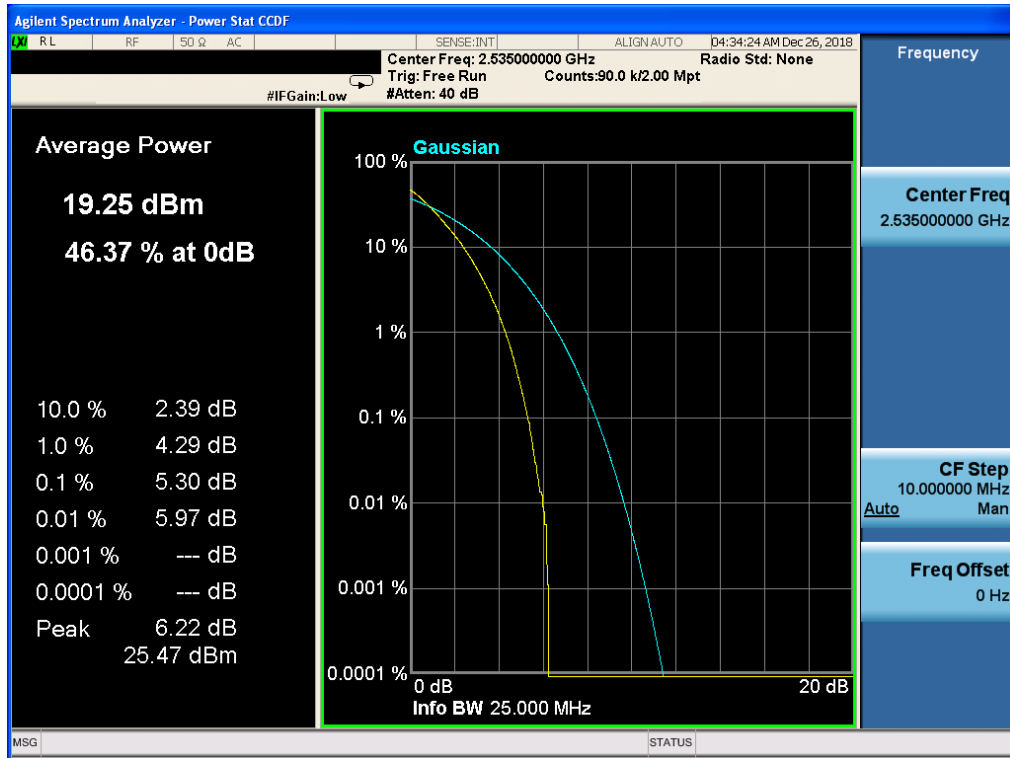

Band 7, UL Channel 21100, UL Frequency 2535.0, BW 20.0, NO. RB 1, RB POS. Low, 16-QAM

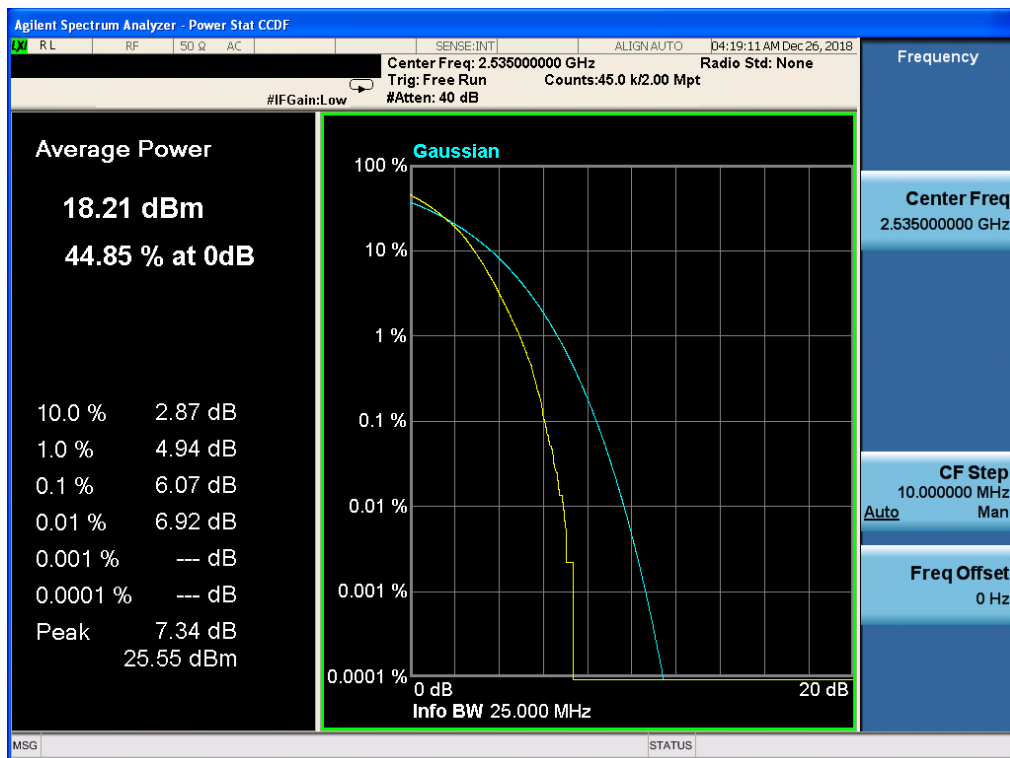

### 11.7 LTE BAND 41

Band 41, UL Channel 40620, UL Frequency 2593.0, BW 5.0, NO. RB 1, RB POS. Low, QPSK

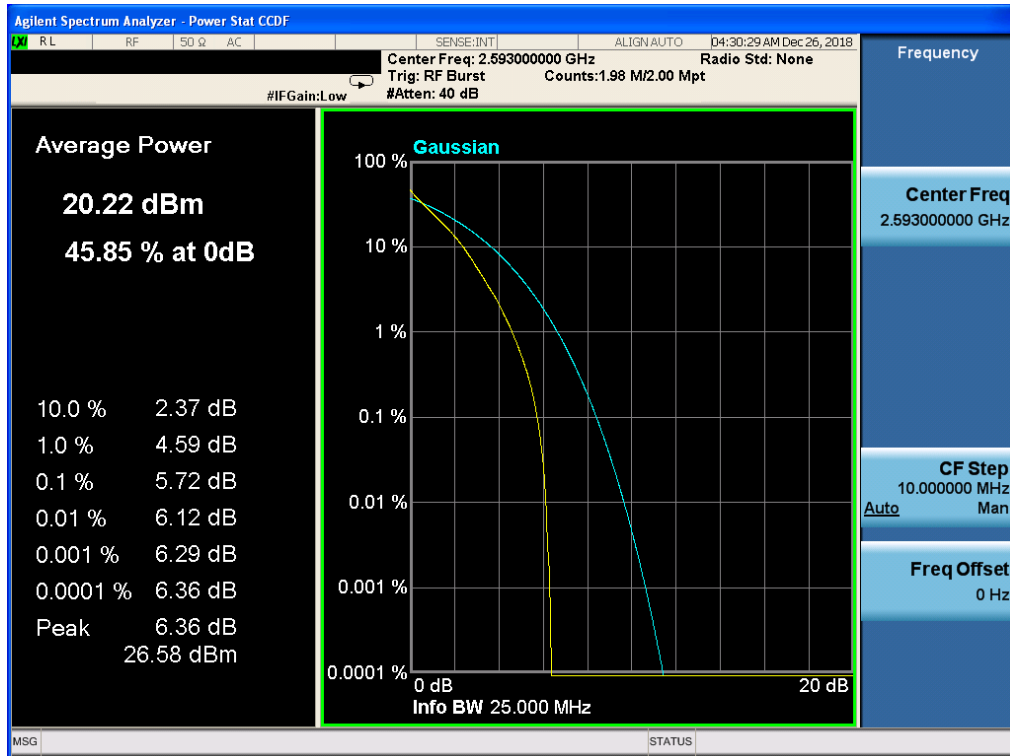

Band 41, UL Channel 40620, UL Frequency 2593.0, BW 5.0, NO. RB 1, RB POS. Low, 16-QAM

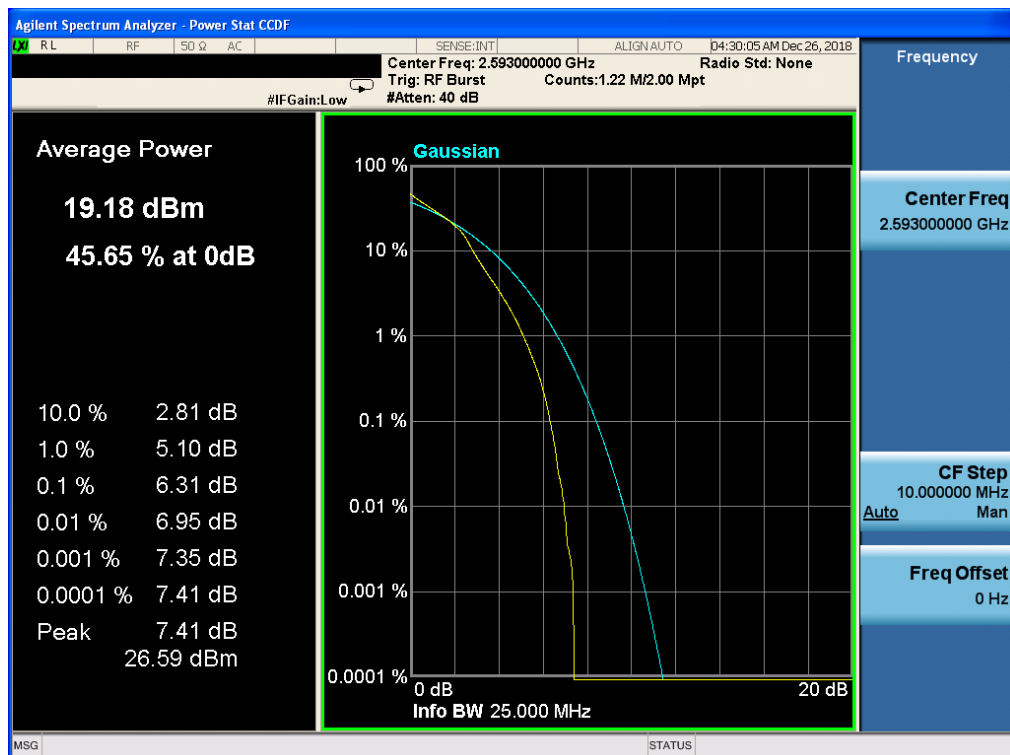

Band 41, UL Channel 40620, UL Frequency 2593.0, BW 10.0, NO. RB 1, RB POS. Low, QPSK

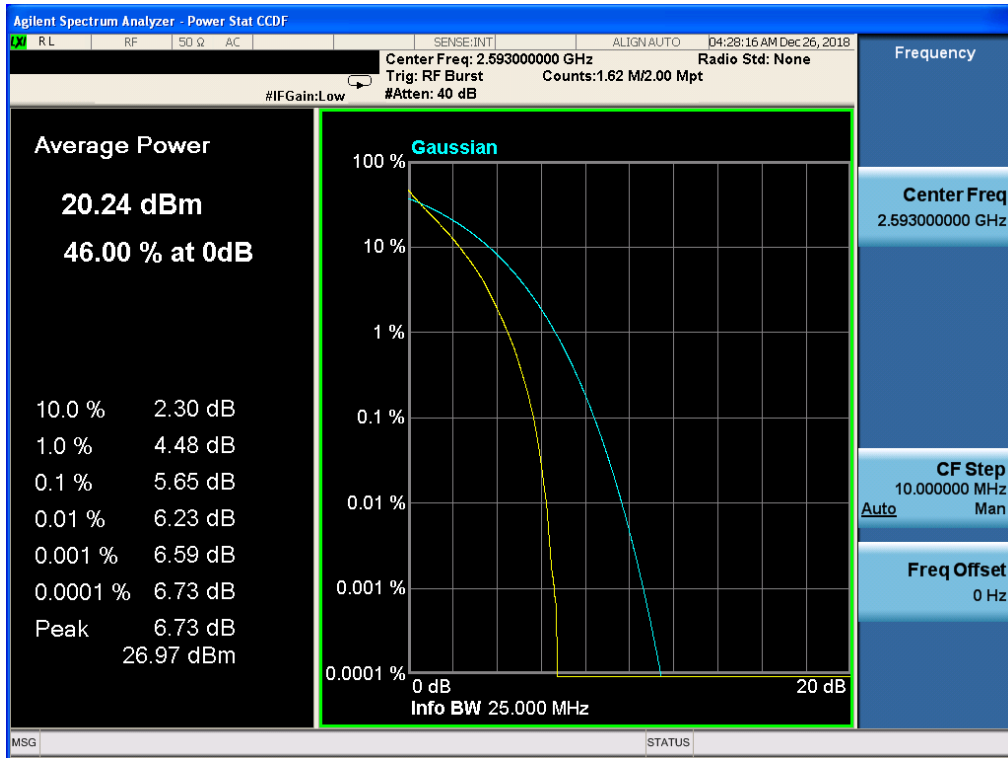

Band 41, UL Channel 40620, UL Frequency 2593.0, BW 10.0, NO. RB 1, RB POS. Low, 16-QAM

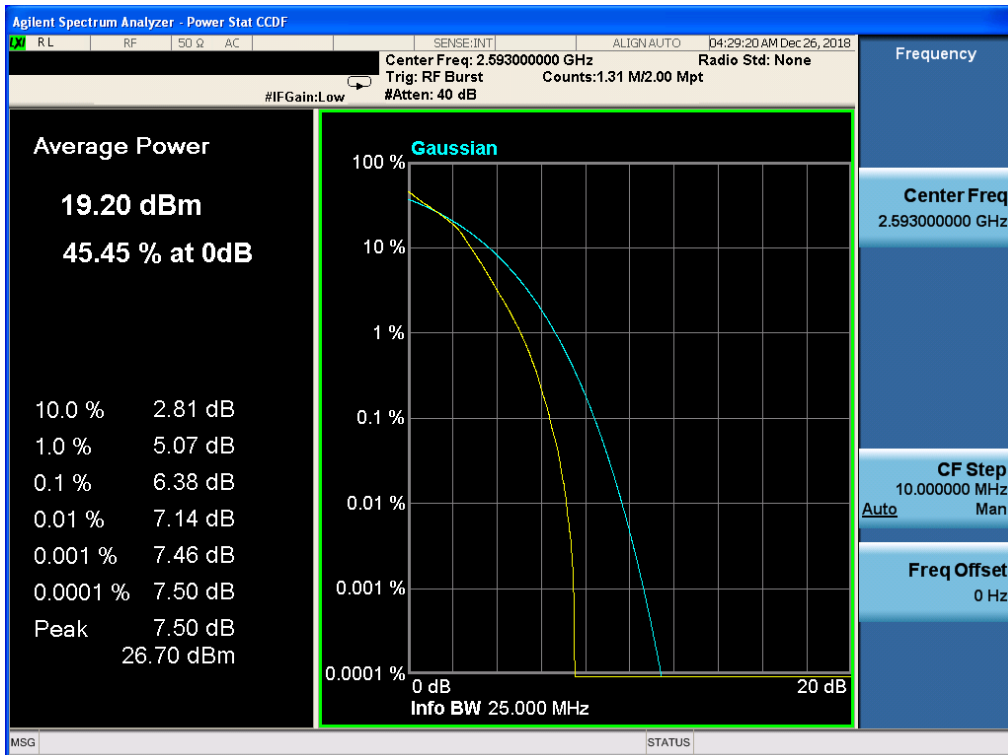

Band 41, UL Channel 40620, UL Frequency 2593.0, BW 15.0, NO. RB 1, RB POS. Low, QPSK

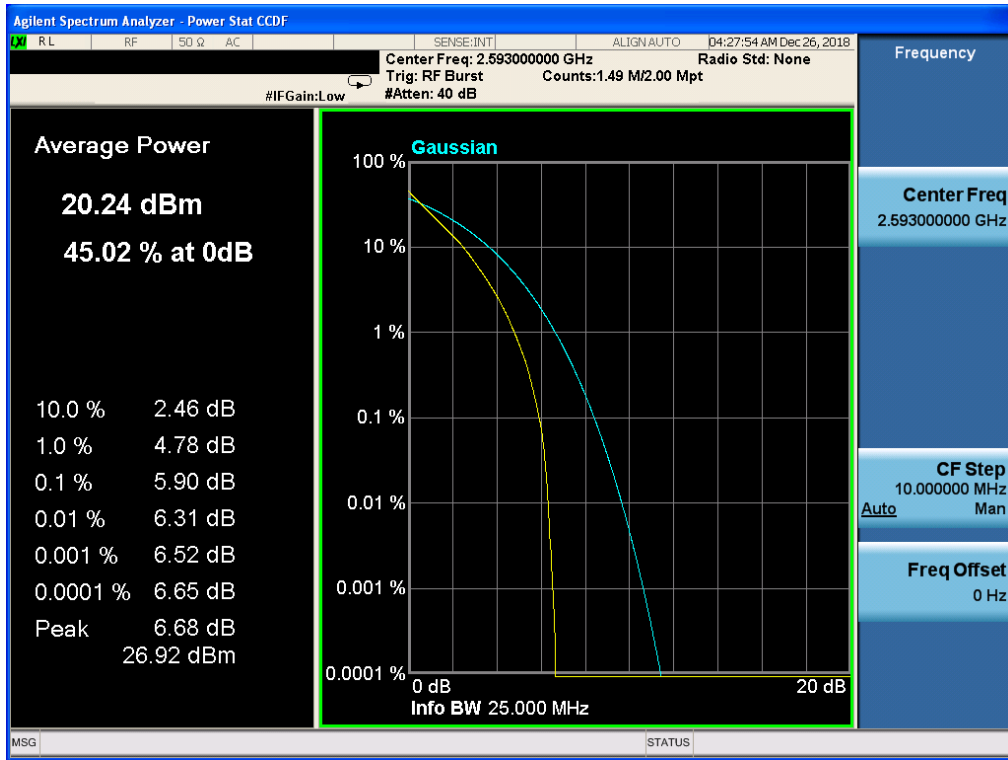

Band 41, UL Channel 40620, UL Frequency 2593.0, BW 15.0, NO. RB 1, RB POS. Low, 16-QAM

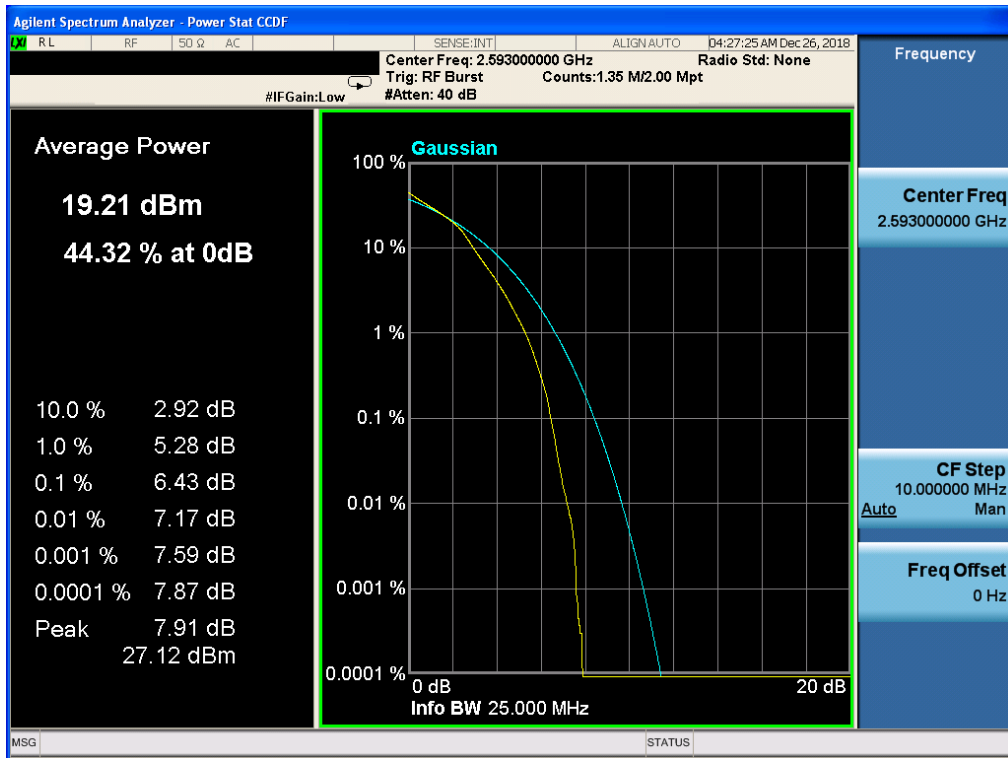

Band 41, UL Channel 40620, UL Frequency 2593.0, BW 20.0, NO. RB 1, RB POS. Low, QPSK

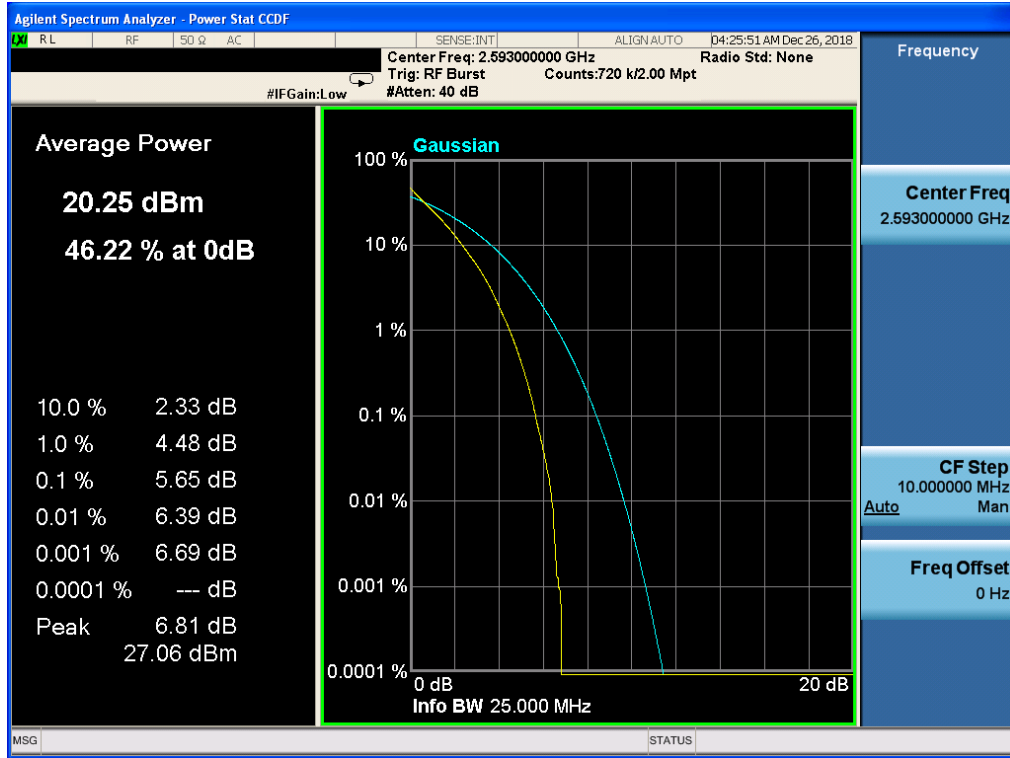

Band 41, UL Channel 40620, UL Frequency 2593.0, BW 20.0, NO. RB 1, RB POS. Low, 16-QAM

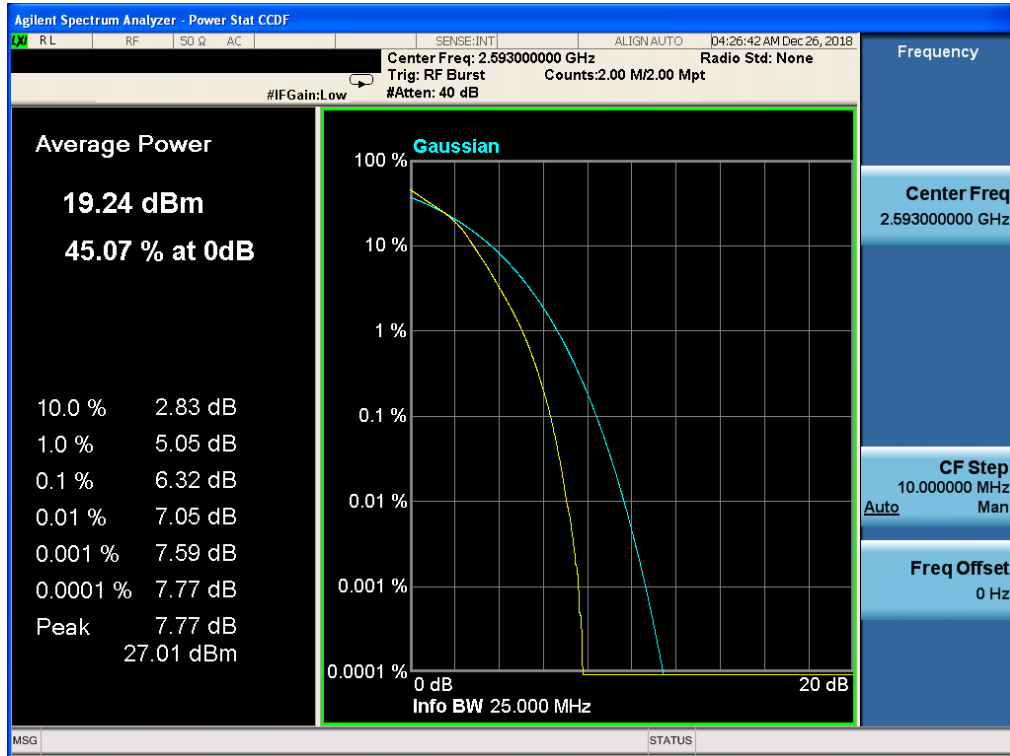

----END OF REPORT----