



MEASUREMENT REPORT

FCC PART 15.247

FCC ID: 2ASGB-US142019

APPLICANT: Impossible Aerospace Corporation

Application Type: Certification

Product: 2.4GHz HD Wireless Link

Model No.: IAUS11901a, IAUS11901b, IAUS11901c

Brand Name: Impossible Radio -1

FCC Classification: Digital Transmission System (DTS)

FCC Rule Part(s): Part 15 Subpart C (Section 15.247)

Test Procedure(s): ANSI C63.10-2013, KDB 558074 D01v05r02

Test Date: April 13 ~ 24, 2019

Reviewed By:

Kevin Guo

(Kevin Guo)

Approved By:

Robin Wu

(Robin Wu)



The test results relate only to the samples tested.

This equipment has been shown to be capable of compliance with the applicable technical standards as indicated in the measurement report and was tested in accordance with the measurement procedures specified in ANSI C63.10-2013. Test results reported herein relate only to the item(s) tested.

The test report shall not be reproduced except in full without the written approval of MRT Technology (Suzhou) Co., Ltd.

Revision History

Report No.	Version	Description	Issue Date	Note
1904RSU030-U1	Rev. 01	Initial Report	04-26-2019	Valid

CONTENTS

Description	Page
§2.1033 General Information.....	5
1. INTRODUCTION.....	6
1.1. Scope.....	6
1.2. MRT Test Location.....	6
2. PRODUCT INFORMATION.....	7
2.1. Feature of Equipment under Test.....	7
2.2. Product Specification Subjective to this Report.....	7
2.3. Working Frequencies for this report.....	7
2.4. Description of Available Antennas.....	8
2.5. Description of Antenna RF Port.....	8
2.6. Test Mode.....	8
2.7. Device Capabilities.....	9
2.8. Test Configuration.....	10
2.9. EMI Suppression Device(s)/Modifications.....	10
2.10. Labeling Requirements.....	10
3. DESCRIPTION of TEST.....	11
3.1. Evaluation Procedure.....	11
3.2. AC Line Conducted Emissions.....	11
3.3. Radiated Emissions.....	12
4. ANTENNA REQUIREMENTS.....	13
5. TEST EQUIPMENT CALIBRATION DATE.....	14
6. MEASUREMENT UNCERTAINTY.....	16
7. TEST RESULT.....	17
7.1. Summary.....	17
7.2. 6dB Bandwidth Measurement.....	18
7.2.1. Test Limit.....	18
7.2.2. Test Procedure used.....	18
7.2.3. Test Setting.....	18
7.2.4. Test Setup.....	18
7.2.5. Test Result.....	19
7.3. Output Power Measurement.....	23
7.3.1. Test Limit.....	23
7.3.2. Test Procedure Used.....	23

7.3.3.	Test Setting.....	23
7.3.4.	Test Setup	23
7.3.5.	Test Result.....	24
7.4.	Power Spectral Density Measurement.....	26
7.4.1.	Test Limit	26
7.4.2.	Test Procedure Used	26
7.4.3.	Test Setting.....	26
7.4.4.	Test Setup	27
7.4.5.	Test Result.....	28
7.5.	Conducted Band Edge and Out-of-Band Emissions	32
7.5.1.	Test Limit	32
7.5.2.	Test Procedure Used	32
7.5.3.	Test Settintg.....	32
7.5.4.	Test Setup	33
7.5.5.	Test Result.....	34
7.6.	Radiated Spurious Emission Measurement.....	41
7.6.1.	Test Limit	41
7.6.2.	Test Procedure Used	41
7.6.3.	Test Setting.....	41
7.6.4.	Test Setup	43
7.6.5.	Test Result.....	44
7.7.	Radiated Restricted Band Edge Measurement.....	56
7.7.1.	Test Limit	56
7.7.2.	Test Procedure Used	57
7.7.3.	Test Setting.....	57
7.7.4.	Test Setup	58
7.7.5.	Test Result.....	59
7.8.	AC Conducted Emissions Measurement	87
7.8.1.	Test Limit	87
7.8.2.	Test Setup	87
7.8.3.	Test Result.....	88
8.	CONCLUSION	90
	Appendix A – Test Setup Photograph	91
	Appendix B – EUT Photograph.....	92

§2.1033 General Information

Applicant:	Impossible Aerospace Corporation
Applicant Address:	2222 Ronald Street, Santa Clara, CA 95050 USA
Manufacturer:	Taisync Technology LLC
Manufacturer Address:	4620 Fortran Drive, Suite 209, San Jose, CA 95134
Test Site:	MRT Technology (Suzhou) Co., Ltd
Test Site Address:	D8 Building, No.2 Tian'edang Rd., Wuzhong Economic Development Zone, Suzhou, China
Test Device Serial No.:	N/A <input type="checkbox"/> Production <input checked="" type="checkbox"/> Pre-Production <input type="checkbox"/> Engineering

Test Facility / Accreditations

Measurements were performed at MRT Laboratory located in Tian'edang Rd., Suzhou, China.

- MRT facility is a FCC registered (MRT Reg. No. 893164) test facility with the site description report on file and has met all the requirements specified in ANSI C63.4-2014.
- MRT facility is an IC registered (MRT Reg. No. 11384A-1) test laboratory with the site description on file at Industry Canada.
- MRT facility is a VCCI registered (R-20025, G-20034, C-20020, T-20020) test laboratory with the site description on file at VCCI Council.
- MRT Lab is accredited to ISO 17025 by the American Association for Laboratory Accreditation (A2LA) under the American Association for Laboratory Accreditation Program (A2LA Cert. No. 3628.01) in EMC, Telecommunications, Radio and SAR testing.



1. INTRODUCTION

1.1. Scope

Measurement and determination of electromagnetic emissions (EMC) of radio frequency devices including intentional and/or unintentional radiators for compliance with the technical rules and regulations of the Federal Communications Commission and the Industry Canada Certification and Engineering Bureau.

1.2. MRT Test Location

The map below shows the location of the MRT LABORATORY, its proximity to the Taihu Lake. These measurement tests were conducted at the MRT Technology (Suzhou) Co., Ltd. Facility located at D8 Building, No.2 Tian'edang Rd., Wuzhong Economic Development Zone, Suzhou, China. The measurement facility compliant with the test site requirements specified in ANSI C63.4-2014.



2. PRODUCT INFORMATION

2.1. Feature of Equipment under Test

Product Name:	2.4GHz HD Wireless Link
Model No.:	IAUS11901a, IAUS11901b, IAUS11901c
Brand Name:	Impossible Radio -1
RF Specification:	2.4GHz
Working Voltage:	DC 5V

Note 1: These models are different in the shape of their shielding enclosures, which are used to accommodate different mounting configurations. The material and PCBA are the same.

Note 2: Due to 3 models has the same shielding cavity, and the more similar shape between IAUS11901a and IAUS11901b, so we select IAUS11901a for all tests and verify RSE & Band Edge test of one channel for IAUS11901c according to IAUS11901a's test result in this report.

2.2. Product Specification Subjective to this Report



RF Specification	
Frequency Range:	2412 ~ 2472 MHz
Type of Modulation:	OFDM
Channel Bandwidth	2.5MHz / 10MHz
Data Rate:	Bandwidth 2.5MHz: 115200kbps Bandwidth 10MHz: 2.3 Mbps ~ 12Mbps

2.3. Working Frequencies for this report

2.4G 2.5MHz/10MHz

Channel	Frequency	Channel	Frequency	Channel	Frequency
01	2412 MHz	02	2417 MHz	03	2422 MHz
04	2427 MHz	05	2432 MHz	06	2437 MHz
07	2442 MHz	08	2447 MHz	09	2452 MHz
10	2457 MHz	11	2462 MHz	12	2467 MHz
13	2472 MHz	--	--	--	--

2.4. Description of Available Antennas

Antenna Plots	Antenna Type	Manufacturer	Frequency Band (GHz)	Max Peak Gain (dBi)
	Dipole Antenna 1#	Saixun	2.4 ~ 2.5	5.0
	PCB Antenna 2#	Airgain	2.4 ~ 2.5	2.0

Note: When operating at 2.5MHz BW status, only dipole antenna 1# can be used. When operating at 2.5MHz and 10MHz BWs status, both antennas can be used.

These information will be shown in operational description and user manual by manufacturer.

2.5. Description of Antenna RF Port

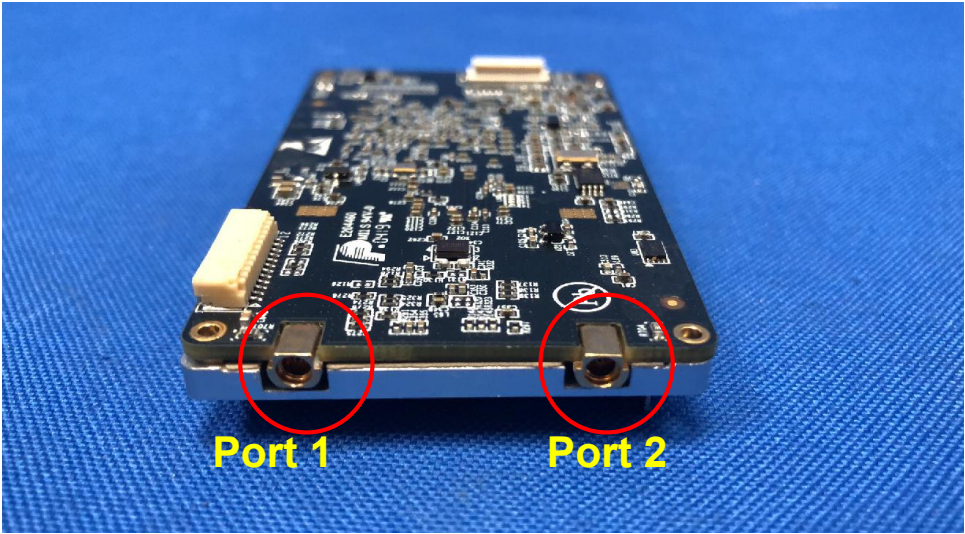
2.4GHz RF Port	
Port 1	Port 2
	
<p>Note: Only port 1 can be used, port 2 is reserved and its function had been shut down.</p>	

2.6. Test Mode

Test Mode	Mode 1: Transmit by Bandwidth 10MHz (2.3Mbps)
	Mode 2: Transmit by Bandwidth 2.5MHz (115200kbps)

2.7. Device Capabilities

This device contains the following capabilities:

2.4G radio frequency with 10MHz and 2.5MHz Bandwidth.

The maximum achievable duty cycles for all modes were determined based on measurements performed on a spectrum analyzer in zero-span mode with RBW = 8MHz, VBW = 50MHz, and detector = peak. The RBW and VBW were both greater than 50/T, where T is the minimum transmission duration, and the number of sweep points across T was greater than 100. The duty cycles are as follows:

Test Mode / Bandwidth	Duty Cycle
10MHz	92.01 %
2.5MHz	97.28 %

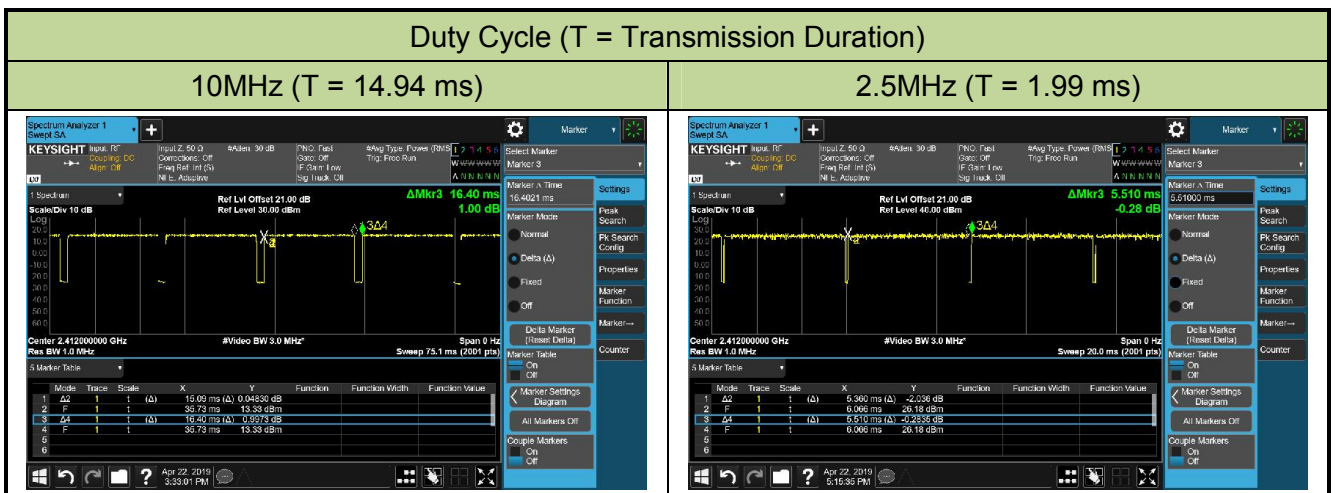

2.8. Test Configuration

The device was tested per the guidance of ANSI C63.10-2013. ANSI C63.10-2013 was used to reference the appropriate EUT setup for radiated spurious emissions testing and AC line conducted testing.

2.9. Test Software

The test utility software used during testing was “Taisync Wireless app”, and the version was “V2.55T”.

2.10. EMI Suppression Device(s)/Modifications

No EMI suppression device(s) were added and/or no modifications were made during testing.

2.11. Labeling Requirements

Per 2.1074 & 15.19; Docket 95-19

The label shall be permanently affixed at a conspicuous location on the device; instruction manual or pamphlet supplied to the user and be readily visible to the purchaser at the time of purchase. However, when the device is so small wherein placement of the label with specified statement is not practical, only the FCC ID must be displayed on the device per Section 15.19(a)(5). Please see attachment for FCC ID label and label location.

3. DESCRIPTION of TEST

3.1. Evaluation Procedure

The measurement procedures described in the American National Standard for Testing Unlicensed Wireless Devices (ANSI C63.10-2013), and the guidance was used in the measurement of the device.

Deviation from measurement procedure.....None

3.2. AC Line Conducted Emissions

The line-conducted facility is located inside an 8'x4'x4' shielded enclosure. A 1m x 2m wooden table 80cm high is placed 40cm away from the vertical wall and 80cm away from the sidewall of the shielded room. Two 10kHz-30MHz, 50Ω/50uH Line-Impedance Stabilization Networks (LISNs) are bonded to the shielded room floor. Power to the LISNs is filtered by external high-current high-insertion loss power line filters. These filters attenuate ambient signal noise from entering the measurement lines. These filters are also bonded to the shielded enclosure.

The EUT is powered from one LISN and the support equipment is powered from the second LISN. All interconnecting cables more than 1 meter were shortened to a 1 meter length by non-inductive bundling (serpentine fashion) and draped over the back edge of the test table. All cables were at least 40cm above the horizontal reference ground-plane. Power cables for support equipment were routed down to the second LISN while ensuring that that cables were not draped over the second LISN.

Sufficient time for the EUT, support equipment, and test equipment was allowed in order for them to warm up to their normal operating condition. The RF output of the LISN was connected to the receiver and exploratory measurements were made to determine the frequencies producing the maximum emission from the EUT. The receiver was scanned from 150kHz to 30MHz. The detector function was set to peak mode for exploratory measurements while the bandwidth of the analyzer was set to 9kHz. The EUT, support equipment, and interconnecting cables were arranged and manipulated to maximize each emission. Each emission was also maximized by varying: power lines, the mode of operation or data exchange speed, or support equipment whichever determined the worst-case emission. Once the worst case emissions have been identified, the one EUT cable configuration/arrangement and mode of operation that produced these emissions are used for final measurements on the same test site. The analyzer is set to CISPR quasi-peak and average detectors with a 9kHz resolution bandwidth for final measurements.

An extension cord was used to connect to a single LISN which powered by EUT. The extension cord was calibrated with LISN, the impedance and insertion loss are compliance with the requirements as stated in ANSI C63.10-2013.

3.3. Radiated Emissions

The radiated test facilities consisted of an indoor 3 meter semi-anechoic chamber used for final measurements and exploratory measurements, when necessary. The measurement area is contained within the semi-anechoic chamber which is shielded from any ambient interference. For measurements above 1GHz absorbers are arranged on the floor between the turn table and the antenna mast in such a way so as to maximize the reduction of reflections. For measurements below 1GHz, the absorbers are removed. A MF Model 210SS turntable is used for radiated measurement. It is a continuously rotatable, remote controlled, metallic turntable and 2 meters (6.56 ft.) in diameter. The turn table is flush with the raised floor of the chamber in order to maintain its function as a ground plane. An 80cm high PVC support structure is placed on top of the turntable.

For all measurements, the spectrum was scanned through all EUT azimuths and from 1 to 4 meter receive antenna height using a broadband antenna from 30MHz up to the upper frequency shown in 15.33(b)(1) depending on the highest frequency generated or used in the device or on which the device operates or tunes. For frequencies above 1GHz, linearly polarized double ridge horn antennas were used. For frequencies below 30MHz, a calibrated loop antenna was used. When exploratory measurements were necessary, they were performed at 1 meter test distance inside the semi-anechoic chamber using broadband antennas, broadband amplifiers, and spectrum analyzers to determine the frequencies and modes producing the maximum emissions. Sufficient time for the EUT, support equipment, and test equipment was allowed in order for them to warm up to their normal operating condition. The test set-up for frequencies below 1GHz was placed on top of the 0.8 meter high, 1 x 1.5 meter table; and test set-up for frequencies 1-40GHz was placed on top of the 1.5 meter high, 1 x 1.5 meter table. The EUT, support equipment, and interconnecting cables were arranged and manipulated to maximize each emission. Appropriate precaution was taken to ensure that all emissions from the EUT were maximized and investigated. The system configuration, clock speed, mode of operation or video resolution, if applicable, turntable azimuth, and receive antenna height was noted for each frequency found.

Final measurements were made in the semi-anechoic chamber using calibrated, linearly polarized broadband and horn antennas. The test setup was configured to the setup that produced the worst case emissions. The spectrum analyzer was set to investigate all frequencies required for testing to compare the highest radiated disturbances with respect to the specified limits. The turntable containing the EUT was rotated through 360 degrees and the height of the receive antenna was varied 1 to 4 meters and stopped at the azimuth and height producing the maximum emission. Each emission was maximized by changing the orientation of the EUT through three orthogonal planes and changing the polarity of the receive antenna, whichever produced the worst-case emissions. According to 3dB Beam-Width of horn antenna, the horn antenna should be always directed to the EUT when rising height.

4. ANTENNA REQUIREMENTS

Excerpt from §15.203 of the FCC Rules/Regulations:

“An intentional radiator antenna shall be designed to ensure that no antenna other than that furnished by the responsible party can be used with the device. The use of a permanently attached antenna or of an antenna that uses a unique coupling to the intentional radiator shall be considered sufficient to comply with the provisions of this section.”

- There are provisions for special connector (MMCX PLUG connector) to an external antenna.

Conclusion:

The device unit complies with the requirement of §15.203.

5. TEST EQUIPMENT CALIBRATION DATE

Conducted Emissions - SR2

Instrument	Manufacturer	Type No.	Asset No.	Cali. Interval	Cali. Due Date
EMI Test Receiver	R&S	ESR3	MRTSUE06185	1 year	2020/04/15
Two-Line V-Network	R&S	ENV 216	MRTSUE06002	1 year	2019/06/14
Two-Line V-Network	R&S	ENV 216	MRTSUE06003	1 year	2019/06/14
Thermohygrometer	Testo	608-H1	MRTSUE06404	1 year	2019/08/14
Shielding Anechoic Chamber	MIX-BEP	Chamber-SR2	MRTSUE06214	N/A	N/A

Radiated Emissions - AC1

Instrument	Manufacturer	Type No.	Asset No.	Cali. Interval	Cali. Due Date
EMI Test Receiver	R&S	ESR7	MRTSUE06001	1 year	2019/08/13
PXA Signal Analyzer	Keysight	9030B	MRTSUE06395	1 year	2019/09/25
Loop Antenna	Schwarzbeck	FMZB 1519	MRTSUE06025	1 year	2019/11/09
Bilog Period Antenna	Schwarzbeck	VULB 9168	MRTSUE06172	1 year	2020/03/31
Broad Band Horn Antenna	Schwarzbeck	BBHA 9120D	MRTSUE06023	1 year	2019/10/19
Broad Band Horn Antenna	Schwarzbeck	BBHA 9170	MRTSUE06024	1 year	2019/12/17
Microwave System Amplifier	Agilent	83017A	MRTSUE06076	1 year	2019/11/16
Preamplifier	Schwarzbeck	BBV 9721	MRTSUE06121	1 year	2019/06/12
Thermohygrometer	Testo	608-H1	MRTSUE06403	1 year	2019/08/14
Anechoic Chamber	TDK	Chamber-AC1	MRTSUE06213	1 year	2019/05/01

Radiated Emission - AC2

Instrument	Manufacturer	Type No.	Asset No.	Cali. Interval	Cali. Due Date
Spectrum Analyzer	Keysight	N9038A	MRTSUE06125	1 year	2019/08/13
Loop Antenna	Schwarzbeck	FMZB 1519	MRTSUE06025	1 year	2019/11/09
Bilog Period Antenna	Schwarzbeck	VULB 9162	MRTSUE06022	1 year	2019/10/19
Horn Antenna	Schwarzbeck	BBHA9120D	MRTSUE06171	1 year	2019/11/09
Broad Band Horn Antenna	Schwarzbeck	BBHA 9170	MRTSUE06024	1 year	2019/12/17
Broadband Coaxial Preamplifier	Schwarzbeck	BBV 9718	MRTSUE06176	1 year	2019/11/16
Preamplifier	Schwarzbeck	BBV 9721	MRTSUE06121	1 year	2019/06/12
Temperature/Humidity Meter	Minggao	ETH529	MRTSUE06170	1 year	2019/12/13
Anechoic Chamber	RIKEN	Chamber-AC2	MRTSUE06213	1 year	2019/05/01

Conducted Test Equipment - TR3

Instrument	Manufacturer	Type No.	Asset No.	Cali. Interval	Cali. Due Date
EXA Signal Analyzer	Agilent	N9020A	MRTSUE06106	1 year	2020/04/15
EXA Signal Analyzer	Keysight	N9010B	MRTSUE06452	1 year	2019/07/19
Power Meter	Agilent	U2021XA	MRTSUE06030	1 year	2019/11/16
USB wideband power sensor	Keysight	U2021XA	MRTSUE06446	1 year	2019/07/19
USB wideband power sensor	Keysight	U2021XA	MRTSUE06447	1 year	2019/07/05
DC Power Supply	GWINSTEK	DPS-3303C	MRTSUE06064	N/A	N/A
Temperature & Humidity Chamber	BAOYT	BYH-150CL	MRTSUE06051	1 year	2019/11/16
Thermohygrometer	testo	608-H1	MRTSUE06401	1 year	2019/08/14

Software	Version	Function
EMI Software	V3	EMI Test Software

6. MEASUREMENT UNCERTAINTY

Where relevant, the following test uncertainty levels have been estimated for tests performed on the EUT as specified in CISPR 16-4-2. This uncertainty represents an expanded uncertainty expressed at approximately the 95% confidence level using a coverage factor of $k = 2$.

AC Conducted Emission Measurement - SR2
Measuring Uncertainty for a Level of Confidence of 95% ($U=2Uc(y)$): 150kHz~30MHz: 3.46dB
Radiated Emission Measurement – AC1
Measuring Uncertainty for a Level of Confidence of 95% ($U=2Uc(y)$): 9kHz ~ 1GHz: 4.18dB 1GHz ~ 25GHz: 4.76dB
Radiated Emission Measurement – AC2
Measuring Uncertainty for a Level of Confidence of 95% ($U=2Uc(y)$): 9kHz ~ 1GHz: 3.86dB 1GHz ~ 25GHz: 4.33dB
Spurious Emissions, Conducted - TR3
Measuring Uncertainty for a Level of Confidence of 95% ($U=2Uc(y)$): 0.78dB
Output Power - TR3
Measuring Uncertainty for a Level of Confidence of 95% ($U=2Uc(y)$): 1.13dB
Power Spectrum Density - TR3
Measuring Uncertainty for a Level of Confidence of 95% ($U=2Uc(y)$): 1.15dB
Occupied Bandwidth - TR3
Measuring Uncertainty for a Level of Confidence of 95% ($U=2Uc(y)$): 0.28%

7. TEST RESULT

7.1. Summary

FCC Part Section(s)	Test Description	Test Limit	Test Condition	Test Result	Reference
15.247(a)(2)	6dB Bandwidth	$\geq 500\text{kHz}$	Conducted	Pass	Section 7.2
15.247(b)(3)	Output Power	$\leq 1\text{ Watt}$		Pass	Section 7.3
15.247(e)	Power Spectral Density	$\leq 8\text{ dBm} / 3\text{kHz}$		Pass	Section 7.4
15.247(d)	Band Edge / Out-of-Band Emissions	$\leq 30\text{dBc (Average)}$		Pass	Section 7.5
15.205 15.209	General Field Strength Limits (Restricted Bands and Radiated Emission Limits)	Emissions in restricted bands must meet the radiated limits detailed in 15.209	Radiated	Pass	Section 7.6 & 7.7
15.207	AC Conducted Emissions 150kHz - 30MHz	$< \text{FCC } 15.207\text{ limits}$	Line Conducted	Pass	Section 7.8

Notes:

- 1) All modes of operation and data rates were investigated. For radiated emission test, every axis (X, Y, Z) was also verified. The test results shown in the following sections represent the worst case emissions.
- 2) The analyzer plots shown in this section were all taken with a correction table loaded into the analyzer. The correction table was used to account for the losses of the cables and attenuators used as part of the system to connect the EUT to the analyzer at all frequencies of interest.
- 3) All channels that reduced power are verified in the band-edge testing, but we reported worst channel data only.

7.2. 6dB Bandwidth Measurement

7.2.1. Test Limit

The minimum 6dB bandwidth shall be at least 500 kHz.

7.2.2. Test Procedure used

ANSI C63.10-2013 Section 11.8

7.2.3. Test Setting

1. The Spectrum's automatic bandwidth measurement capability was used to perform the 6dB bandwidth measurement. The "X" dB bandwidth parameter was set to $X = 6$. The bandwidth measurement was not influenced by any intermediate power nulls in the fundamental emission.
2. Set RBW = 100 kHz
3. VBW $\geq 3 \times$ RBW
4. Detector = Peak
5. Trace mode = max hold
6. Sweep = auto couple
7. Allow the trace was allowed to stabilize

7.2.4. Test Setup

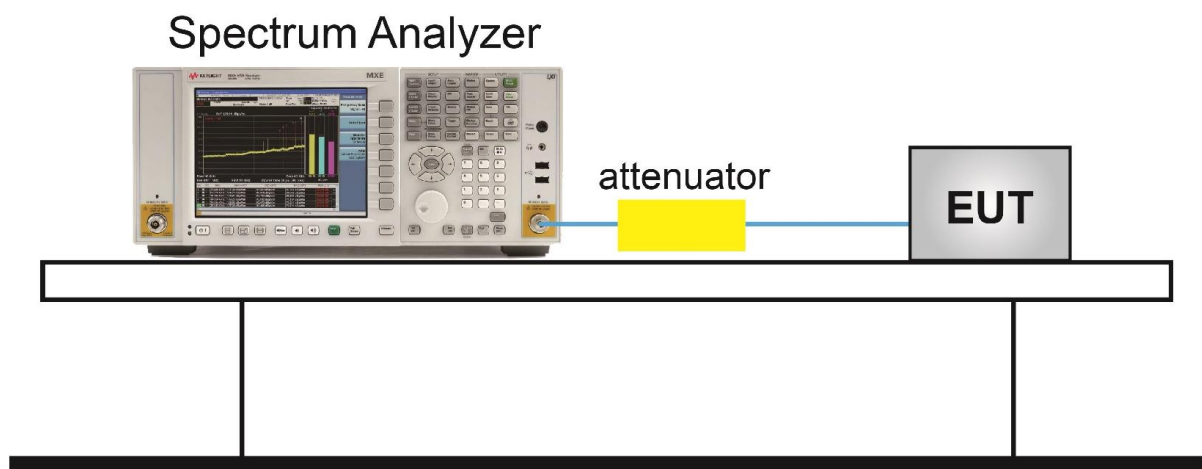

7.2.5. Test Result

Product	2.4GHz HD Wireless Link	Temperature	25°C
Test Engineer	Snake Ni	Relative Humidity	52%
Test Site	TR3	Test Date	2019/04/22

Test Mode / Bandwidth	Data Rate	Channel No.	Frequency (MHz)	6dB Bandwidth (MHz)	Limit (MHz)	Result
Ant 1						
10MHz	2.3Mbps	01	2412	9.11	≥ 0.5	Pass
10MHz	2.3Mbps	07	2442	9.11	≥ 0.5	Pass
10MHz	2.3Mbps	13	2472	9.11	≥ 0.5	Pass
2.5MHz	115200kbps	01	2412	2.30	≥ 0.5	Pass
2.5MHz	115200kbps	07	2442	2.28	≥ 0.5	Pass
2.5MHz	115200kbps	13	2472	2.30	≥ 0.5	Pass
Ant 2						
10MHz	2.3Mbps	01	2412	9.10	≥ 0.5	Pass
10MHz	2.3Mbps	07	2442	9.11	≥ 0.5	Pass
10MHz	2.3Mbps	13	2472	9.10	≥ 0.5	Pass

10MHz BW - 6dB Bandwidth - Ant 1

Channel 01 (2412MHz)

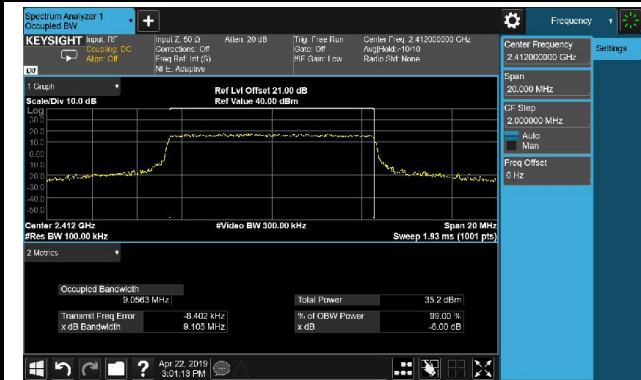

Channel 07 (2442MHz)

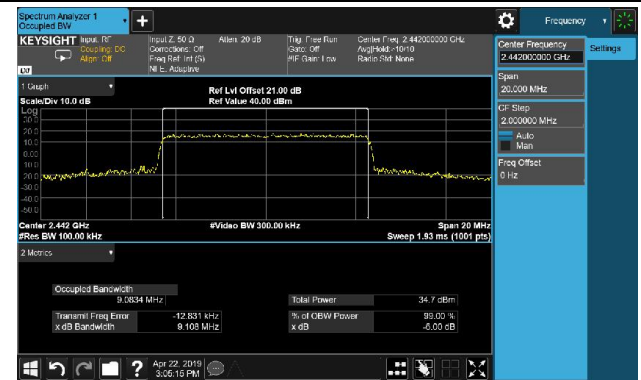

Channel 13 (2472MHz)

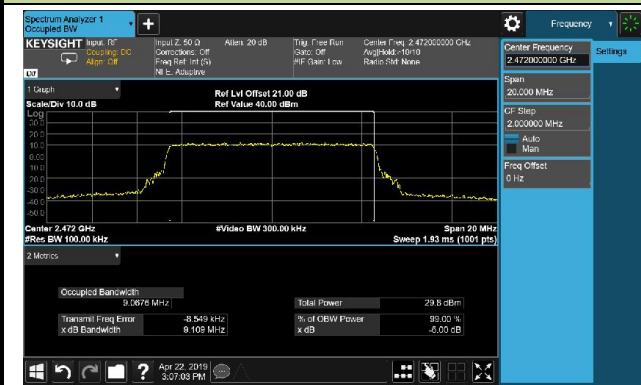

--

--

2.5MHz BW - 6dB Bandwidth - Ant 1

Channel 01 (2412MHz)

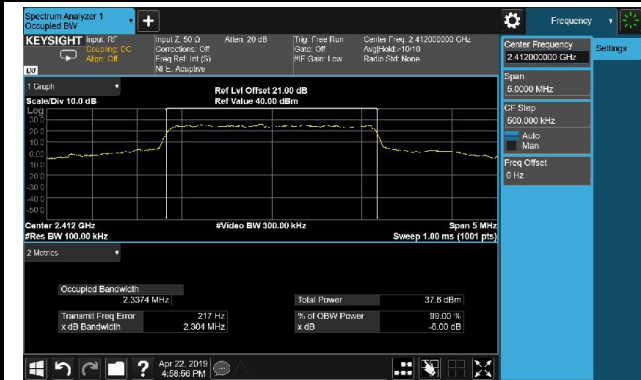

Channel 07 (2442MHz)

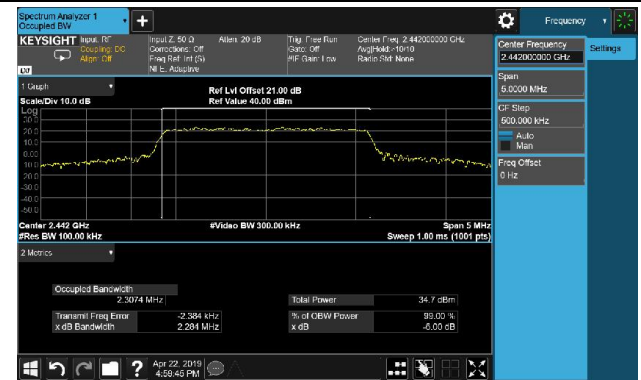

Channel 13 (2472MHz)



--

--

10MHz BW - 6dB Bandwidth - Ant 2

Channel 01 (2412MHz)

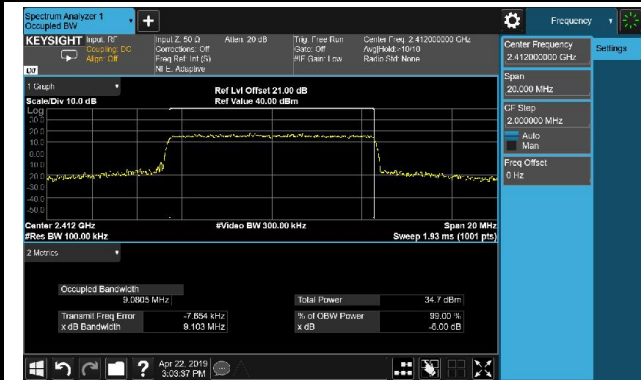

Channel 07 (2442MHz)

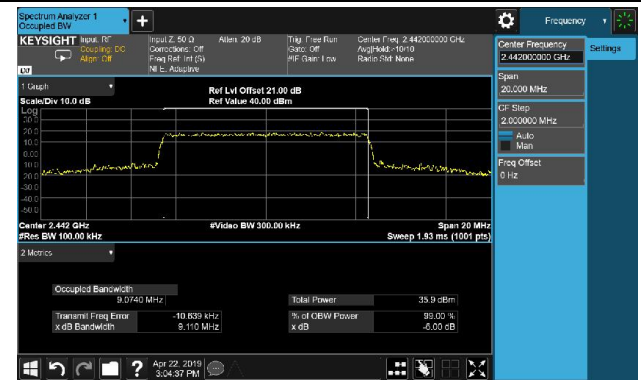

Channel 13 (2472MHz)

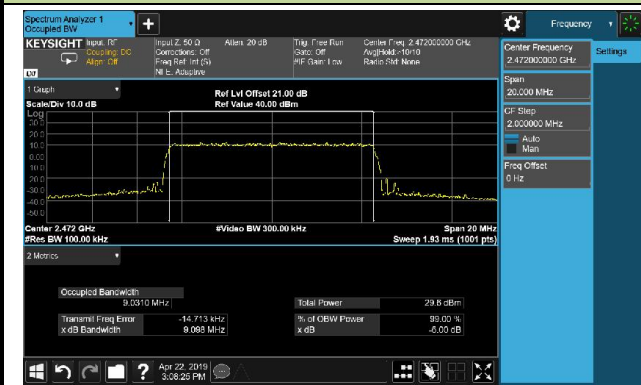

--

--

7.3. Output Power Measurement

7.3.1. Test Limit

The maximum out power shall be less 1 Watt (30dBm).

7.3.2. Test Procedure Used

ANSI C63.10 Section 11.9.2.3.2

7.3.3. Test Setting

Average Power Measurement

Average power measurements were perform only when the EUT was transmitting at its maximum power control level using a broadband power meter with a pulse sensor. The power meter implemented triggering and gating capabilities which were set up such that power measurements were recorded only during the ON time of the transmitter.

7.3.4. Test Setup

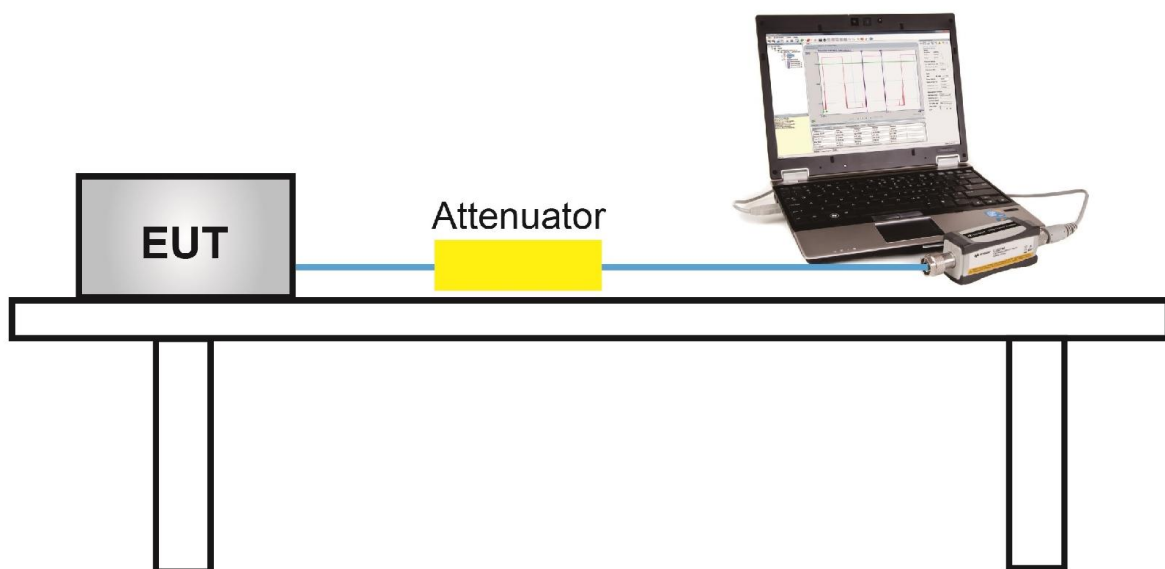

7.3.5. Test Result

Power output test was verified over all data rates of each mode shown as below, and then choose the maximum power output (Gray marker) for final test of each channel.

Output power at various data rates:

Test Mode / Bandwidth	Channel No.	Frequency (MHz)	Data Rate	Average Power (dBm)
10MHz	7	2442	2.3 Mbps	25.97
			6.94 Mbps	25.90
			12 Mbps	25.82
2.5MHz	7	2442	115200kbps	26.88
			--	--
			--	--

Product	2.4GHz HD Wireless Link	Temperature	23°C
Test Engineer	Snake Ni	Relative Humidity	51%
Test Site	TR3	Test Date	2019/04/22

Test Mode / Bandwidth	Data Rate	Channel No.	Freq. (MHz)	Average Power (dBm)	Limit (dBm)	Result
Ant 1						
10MHz	2.3Mbps	1	2412	24.56	≤ 30.00	Pass
	2.3Mbps	7	2442	25.97	≤ 30.00	Pass
	2.3Mbps	13	2472	19.80	≤ 30.00	Pass
2.5MHz	115200kbps	1	2412	27.47	≤ 30.00	Pass
	115200kbps	7	2442	26.29	≤ 30.00	Pass
	115200kbps	13	2472	26.03	≤ 30.00	Pass
Ant 2						
10MHz	2.3Mbps	1	2412	25.40	≤ 30.00	Pass
	2.3Mbps	7	2442	26.88	≤ 30.00	Pass
	2.3Mbps	13	2472	20.84	≤ 30.00	Pass

7.4. Power Spectral Density Measurement

7.4.1. Test Limit

The maximum permissible power spectral density is 8dBm in any 3 kHz band.

The same method of determining the conducted output power shall be used to determine the power spectral density.

7.4.2. Test Procedure Used

ANSI C63.10 Section 11.10.5

7.4.3. Test Setting

1. Measure the duty cycle (x) of the transmitter output signal.
2. Set instrument center frequency to DTS channel center frequency.
3. Set span to at least 1.5 times the OBW.
4. RBW = 10 kHz.
5. VBW = 30 kHz.
6. Detector = RMS.
7. Ensure that the number of measurement points in the sweep $\geq 2 \times \text{span}/\text{RBW}$.
8. Sweep time = auto couple.
9. Don't use sweep triggering. Allow sweep to "free run".
10. Employ trace averaging (RMS) mode over a minimum of 100 traces.
11. Use the peak marker function to determine the maximum amplitude level.
12. Add $10 \log (1/x)$, where x is the duty cycle measured in step (a), to the measured PSD to compute the average PSD during the actual transmission time.

7.4.4. Test Setup

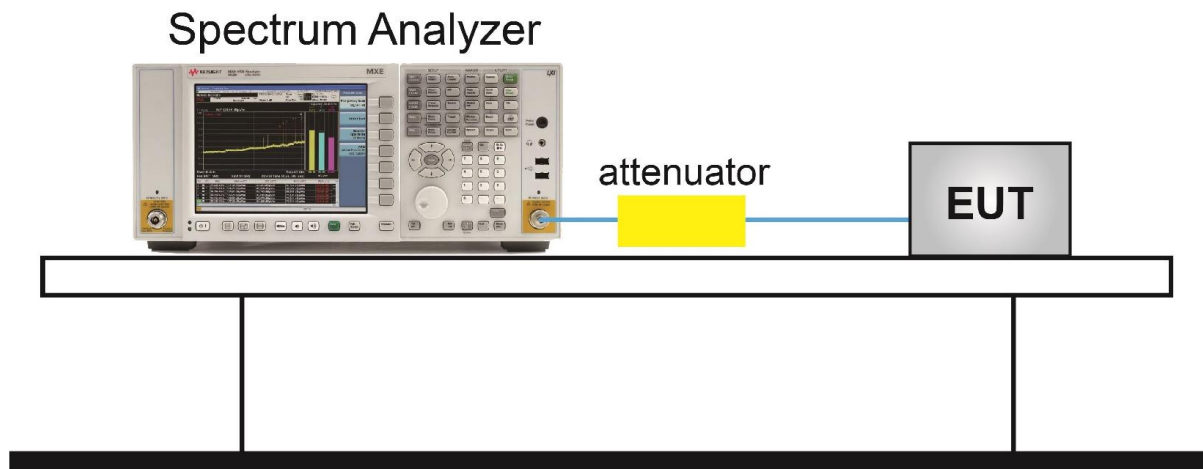

7.4.5. Test Result

Product	2.4GHz HD Wireless Link	Temperature	23°C
Test Engineer	Snake Ni	Relative Humidity	52%
Test Site	TR3	Test Date	2019/04/22

Test Mode	Data Rate	Channel No.	Freq. (MHz)	AVG PSD (dBm / 10kHz)	Duty Cycle (%)	Final AVG PSD (dBm / 3kHz)	Limit (dBm / 3kHz)	Result
Ant 1								
10MHz	2.3Mbps	1	2412	-3.70	92.01	-8.93	≤ 8.00	Pass
	2.3Mbps	7	2442	-1.96	92.01	-7.19	≤ 8.00	Pass
	2.3Mbps	13	2472	-8.14	92.01	-13.37	≤ 8.00	Pass
2.5MHz	115200kbps	1	2412	7.22	91.40	2.38	≤ 8.00	Pass
	115200kbps	7	2442	4.92	91.40	0.08	≤ 8.00	Pass
	115200kbps	13	2472	4.00	91.40	-0.84	≤ 8.00	Pass
Ant 2								
10MHz	2.3Mbps	1	2412	-2.58	92.01	-7.81	≤ 8.00	Pass
	2.3Mbps	7	2442	-1.17	92.01	-6.40	≤ 8.00	Pass
	2.3Mbps	13	2472	-7.39	92.01	-12.62	≤ 8.00	Pass

Note: When EUT duty cycle < 98%, Final AVG PSD (dBm / 3kHz) = AVG PSD + 10*log (1/Duty Cycle).

10MHz PSD - Ant 1

Channel 01 (2412MHz)

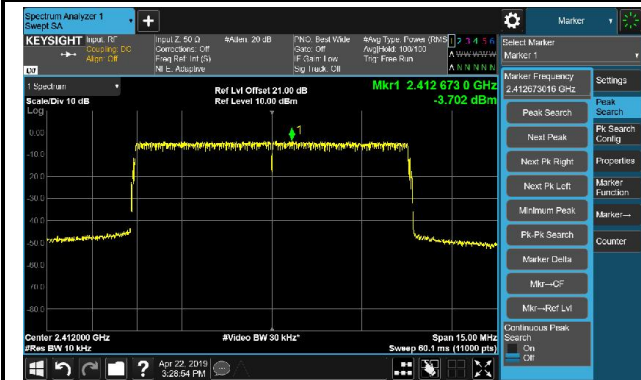

Channel 07 (2442MHz)



Channel 13 (2472MHz)

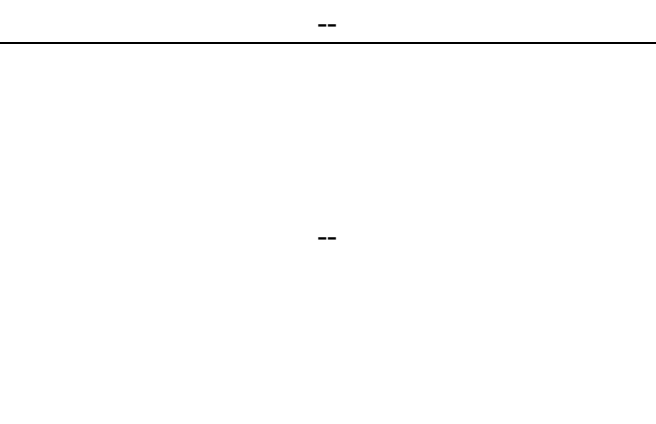

2.5MHz PSD-Ant 1

Channel 01 (2412MHz)



Channel 07 (2442MHz)



Channel 13 (2472MHz)



--

--

10MHz PSD-Ant 2

Channel 01 (2412MHz)



Channel 07 (2442MHz)



Channel 13 (2472MHz)

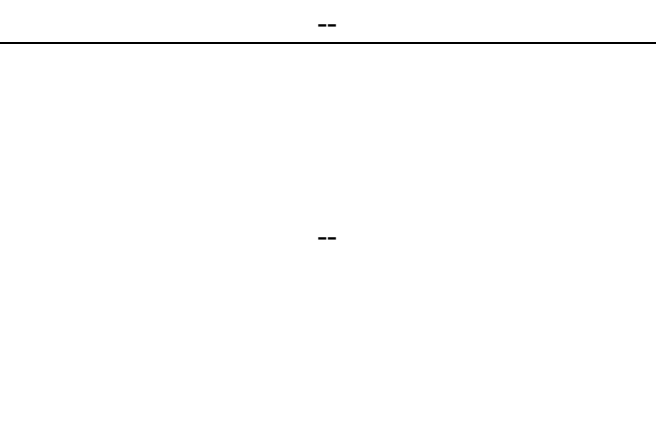
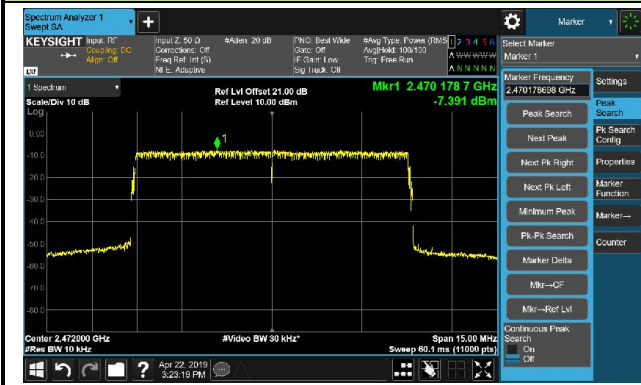

7.5. Conducted Band Edge and Out-of-Band Emissions

7.5.1. Test Limit

The limit for out-of-band spurious emissions at the band edge is 30dB below the fundamental emission level, as determined from the in-band power measurement of the DTS channel performed in a 100 kHz bandwidth per the PSD procedure.

7.5.2. Test Procedure Used

ANSI C63.10 Section 11.11

7.5.3. Test Setting

Reference level measurement

1. Set instrument center frequency to DTS channel center frequency
2. Set the span to ≥ 1.5 times the DTS bandwidth
3. Set the RBW = 100 kHz
4. Set the VBW $\geq 3 \times$ RBW
5. Detector = peak
6. Sweep time = auto couple
7. Trace mode = max hold
8. Allow trace to fully stabilize

Emission level measurement

1. Set the center frequency and span to encompass frequency range to be measured
2. RBW = 100kHz
3. VBW = 300kHz
4. Detector = Peak
5. Trace mode = max hold
6. Sweep time = auto couple
7. The trace was allowed to stabilize

Test Notes

1. RBW was set to 1.3MHz rather than 100 kHz in order to increase the measurement speed.
2. The display line shown in the following plots denotes the limit at 30dB below the fundamental emission level measured in a 100 kHz bandwidth. However, since the traces in the following plots are measured with a 1.3MHz RBW, the display line may not necessarily appear to be 30dB below the level of the fundamental in a 1.3MHz bandwidth.
3. For plots showing conducted spurious emissions near the limit, the frequencies were investigated with a reduced RBW to ensure that no emissions were present

7.5.4. Test Setup

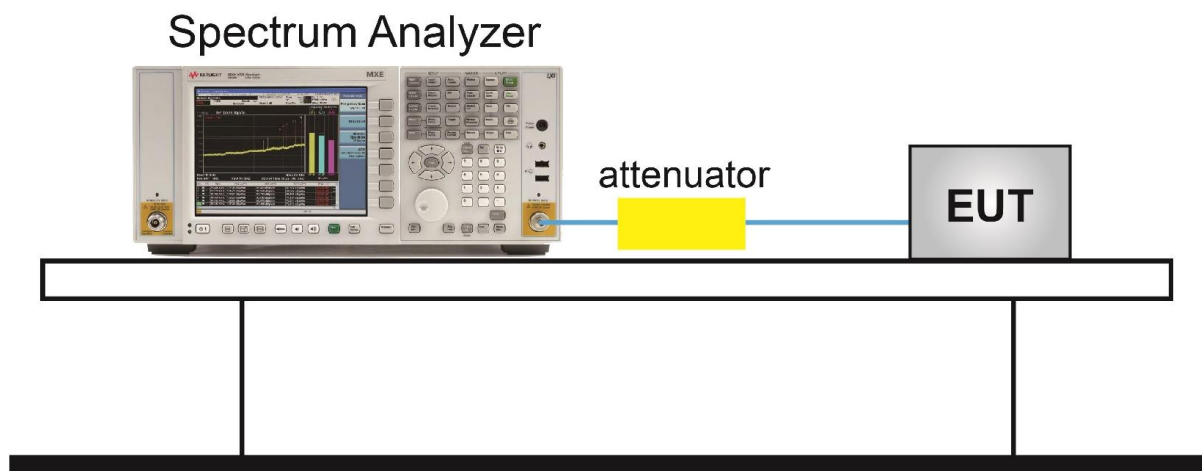

7.5.5. Test Result

Product	2.4GHz HD Wireless Link	Temperature	23°C
Test Engineer	Snake Ni	Relative Humidity	52%
Test Site	TR3	Test Date	2019/04/22

Test Mode / Bandwidth	Data Rate	Channel No.	Frequency (MHz)	Limit	Result
Ant 1					
10MHz	2.3Mbps	01	2412	30dBc	Pass
10MHz	2.3Mbps	07	2442	30dBc	Pass
10MHz	2.3Mbps	13	2472	30dBc	Pass
2.5MHz	115200kbps	01	2412	30dBc	Pass
2.5MHz	115200kbps	07	2442	30dBc	Pass
2.5MHz	115200kbps	13	2472	30dBc	Pass
Ant 2					
10MHz	2.3Mbps	01	2412	30dBc	Pass
10MHz	2.3Mbps	07	2442	30dBc	Pass
10MHz	2.3Mbps	13	2472	30dBc	Pass

10MHz Out-of-Band Emissions - Ant 1

Channel 01 (2412MHz)

100kHz PSD reference Level



Low Band Edge



Spurious Emission

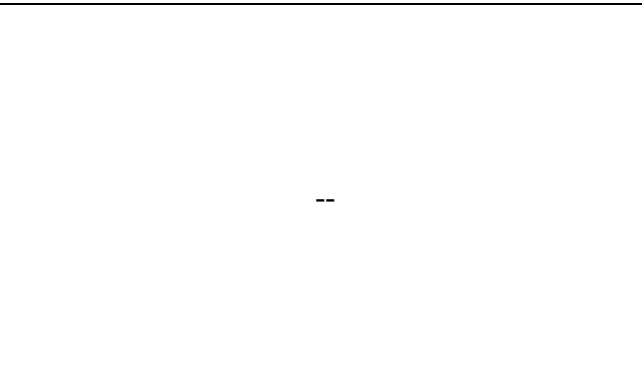

Channel 07 (2442MHz)

100kHz PSD reference Level



Spurious Emission

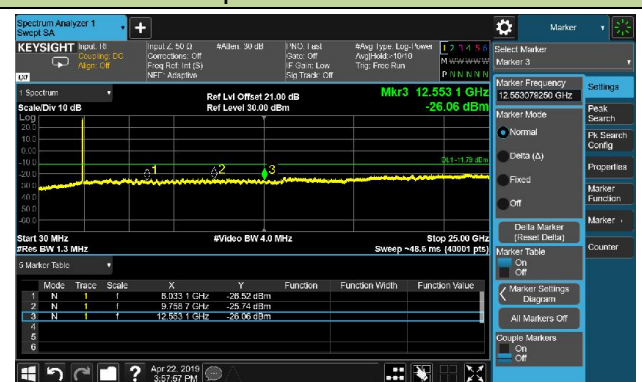

Channel 13 (2472MHz)

100kHz PSD reference Level



High Band Edge



Spurious Emission



--

--

2.5MHz Out-of-Band Emissions - Ant 1

Channel 01 (2412MHz)

100kHz PSD reference Level



Low Band Edge



Spurious Emission

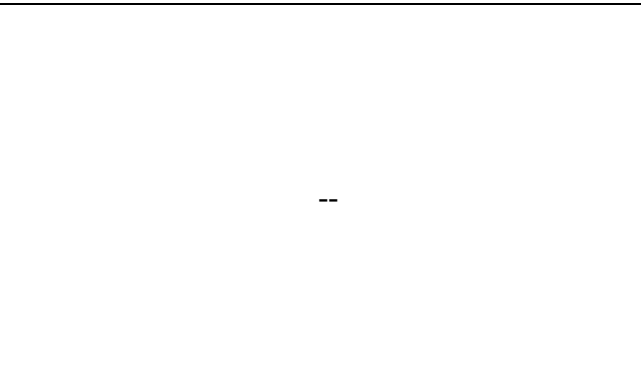

Channel 07 (2442MHz)

100kHz PSD reference Level



Spurious Emission

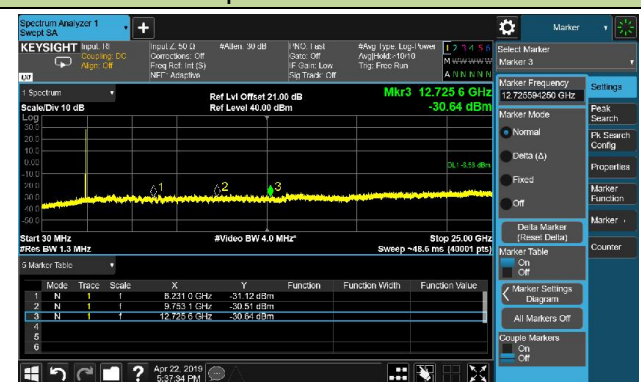

Channel 13 (2472MHz)

100kHz PSD reference Level



High Band Edge



Spurious Emission

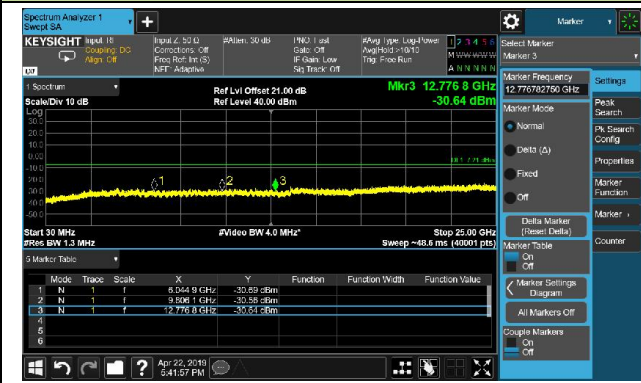

--

--

10MHz Out-of-Band Emissions - Ant 2

Channel 01 (2412MHz)

100kHz PSD reference Level



Low Band Edge



Spurious Emission



--

--

Channel 07 (2442MHz)

100kHz PSD reference Level



Spurious Emission

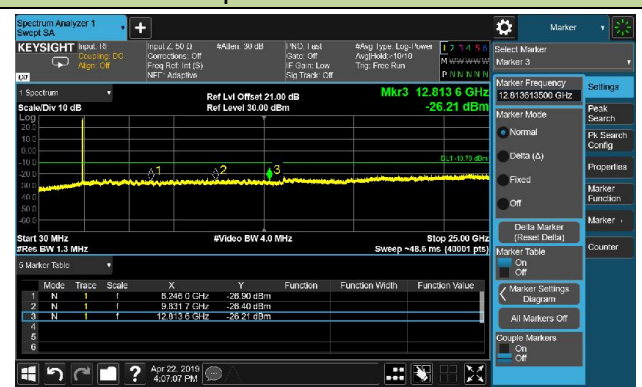

Channel 13 (2472MHz)

100kHz PSD reference Level



High Band Edge

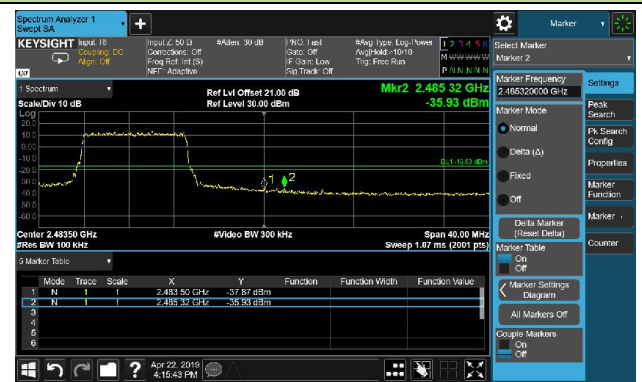

Spurious Emission



--

--

7.6. Radiated Spurious Emission Measurement

7.6.1. Test Limit

All out of band emissions appearing in a restricted band as specified in Section 15.205 of the Title 47 CFR must not exceed the limits shown in Table per Section 15.209.

FCC Part 15 Subpart C Paragraph 15.209		
Frequency [MHz]	Field Strength [uV/m]	Measured Distance [Meters]
0.009 - 0.490	2400/F (kHz)	300
0.490 - 1.705	24000/F (kHz)	30
1.705 - 30	30	30
30 - 88	100	3
88 - 216	150	3
216 - 960	200	3
Above 960	500	3

7.6.2. Test Procedure Used

ANSI C63.10 Section 6.3 (General Requirements)

ANSI C63.10 Section 6.4 (Standard test method below 30MHz)

ANSI C63.10 Section 6.5 (Standard test method above 30MHz to 1GHz)

ANSI C63.10 Section 6.6 (Standard test method above 1GHz)

7.6.3. Test Setting

Quasi-Peak Measurements below 1GHz

1. Analyzer center frequency was set to the frequency of the radiated spurious emission of interest
2. Span was set greater than 1MHz
3. RBW = as specified in Table 1
4. Detector = CISPR quasi-peak or average
5. Sweep time = auto couple
6. Trace was allowed to stabilize

Table 1 - RBW as a function of frequency

Frequency	RBW
9 ~ 150 kHz	200 ~ 300 Hz
0.15 ~ 30 MHz	9 ~ 10 kHz
30 ~ 1000 MHz	100 ~ 120 kHz

Peak Measurements above 1GHz

1. Analyzer center frequency was set to the frequency of the radiated spurious emission of interest
2. RBW = 1MHz
3. VBW = 3MHz
4. Detector = peak
5. Sweep time = auto couple
6. Trace mode = max hold
7. Trace was allowed to stabilize

Average Measurements above 1GHz (Method VB)

1. Analyzer center frequency was set to the frequency of the radiated spurious emission of interest
2. RBW = 1MHz
3. VBW; If the EUT is configured to transmit with duty cycle $\geq 98\%$, set VBW = 10 Hz.
If the EUT duty cycle is $< 98\%$, set VBW $\geq 1/T$. T is the minimum transmission duration.
4. Detector = Peak
5. Sweep time = auto
6. Trace mode = max hold
7. Trace was allowed to stabilize

7.6.4. Test Setup

Below 1GHz Test Setup:

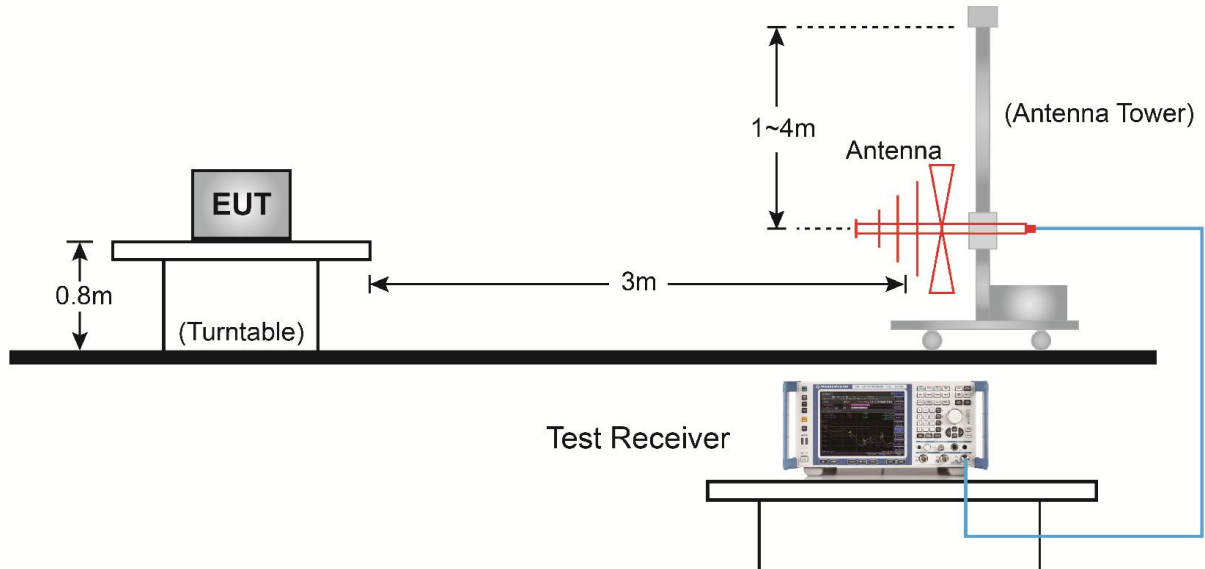

Above 1GHz Test Setup:

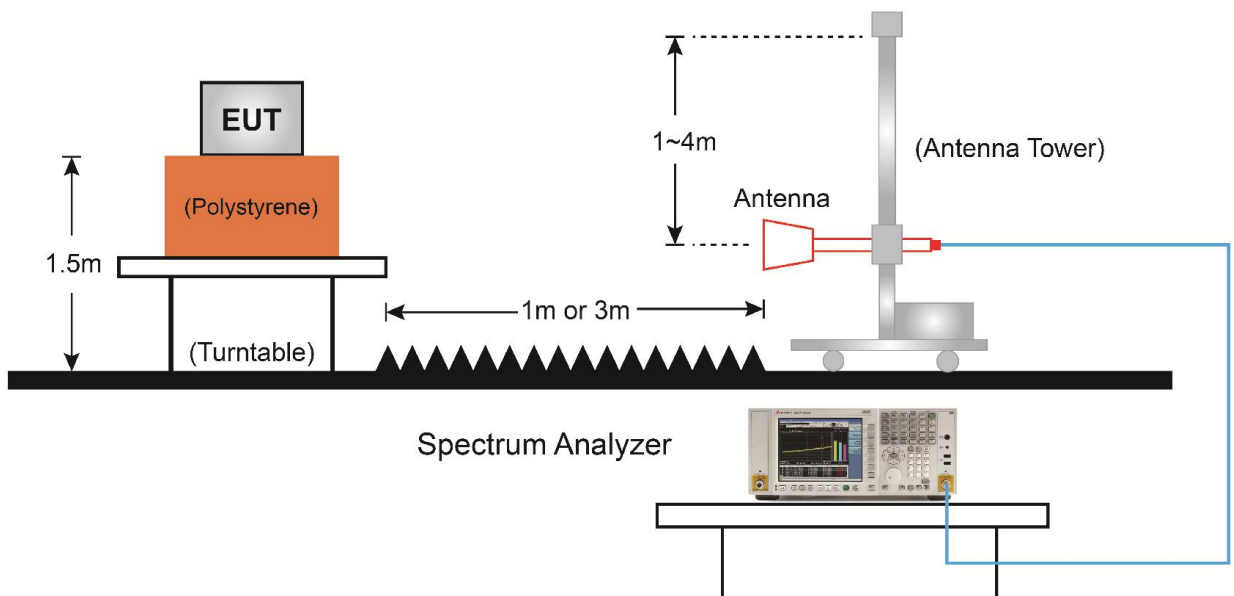

7.6.5. Test Result

Product	2.4GHz HD Wireless Link	Temperature	26°C
Test Engineer	Snake Ni	Relative Humidity	56%
Test Site	AC2	Test Date	2019/04/19
Test Mode:	10MHz Bandwidth - Ant 1	Test Channel:	01
Remark:	1. Average measurement was not performed if peak level lower than average limit. 2. Other frequency was 20dB below limit line within 1-18GHz, there is not show in the report.		

Mark	Frequency (MHz)	Reading Level (dB μ V)	Factor (dB)	Measure Level (dB μ V/m)	Limit (dB μ V/m)	Margin (dB)	Detector	Polarization
	4825.0	43.4	3.6	47.0	74.0	-27.0	Peak	Horizontal
*	7239.0	44.5	11.4	55.9	93.1	-37.2	Peak	Horizontal
*	9644.5	46.6	13.7	60.3	93.1	-32.8	Peak	Horizontal
	11327.0	20.8	19.1	39.9	54.0	-14.1	Average	Horizontal
	11327.5	39.5	19.1	58.6	74.0	-15.4	Peak	Horizontal
	4823.7	42.4	3.6	46.0	54.0	-8.0	Average	Vertical
	4825.0	53.4	3.6	57.0	74.0	-17.0	Peak	Vertical
*	5666.5	59.8	4.7	64.5	93.1	-28.6	Peak	Vertical
*	9644.5	54.1	13.7	67.8	93.1	-25.3	Peak	Vertical
	11335.3	21.3	19.0	40.3	54.0	-13.7	Average	Vertical
	11336.0	45.2	19.0	64.2	74.0	-9.8	Peak	Vertical

Note 1: "*" is not in restricted band, its limit is 30dBc of the fundamental emission level (123.1dB μ V/m) or 15.209 which is higher.

Note 2: Measure Level (dB μ V/m) = Reading Level (dB μ V) + Factor (dB)

Factor (dB) = Cable Loss (dB) + Antenna Factor (dB/m) - Pre_Amplifier Gain (dB)

Product	2.4GHz HD Wireless Link	Temperature	26°C
Test Engineer	Snake Ni	Relative Humidity	56%
Test Site	AC2	Test Date	2019/04/19
Test Mode:	10MHz Bandwidth - Ant 1	Test Channel:	07
Remark:	1. Average measurement was not performed if peak level lower than average limit. 2. Other frequency was 20dB below limit line within 1-18GHz, there is not show in the report.		

Mark	Frequency (MHz)	Reading Level (dBµV)	Factor (dB)	Measure Level (dBµV/m)	Limit (dBµV/m)	Margin (dB)	Detector	Polarization
*	5666.5	51.3	4.7	56.0	96.8	-40.8	Peak	Horizontal
	7324.0	33.5	12.0	45.5	54.0	-8.5	Average	Horizontal
	7324.0	48.9	12.0	60.9	74.0	-13.1	Peak	Horizontal
*	9772.0	44.6	14.0	58.6	96.8	-38.2	Peak	Horizontal
	11333.5	20.6	19.0	39.6	54.0	-14.4	Average	Horizontal
	11336.0	40.8	19.0	59.8	74.0	-14.2	Peak	Horizontal
	4884.4	45.0	3.5	48.5	54.0	-5.5	Average	Vertical
	4893.0	54.3	3.5	57.8	74.0	-16.2	Peak	Vertical
*	5666.5	59.5	4.7	64.2	96.8	-32.6	Peak	Vertical
	7324.0	58.2	12.0	70.2	74.0	-3.8	Peak	Vertical
	7326.3	41.1	11.9	53.0	54.0	-1.0	Average	Vertical
*	9772.0	53.1	14.0	67.1	96.8	-29.7	Peak	Vertical

Note 1: "*" is not in restricted band, its limit is 30dBc of the fundamental emission level (126.8dBµV/m) or 15.209 which is higher.

Note 2: Measure Level (dBµV/m) = Reading Level (dBµV) + Factor (dB)

Factor (dB) = Cable Loss (dB) + Antenna Factor (dB/m) - Pre_Amplifier Gain (dB)

Product	2.4GHz HD Wireless Link	Temperature	26°C
Test Engineer	Snake Ni	Relative Humidity	56%
Test Site	AC2	Test Date	2019/04/19
Test Mode:	10MHz Bandwidth - Ant 1	Test Channel:	13
Remark:	1. Average measurement was not performed if peak level lower than average limit. 2. Other frequency was 20dB below limit line within 1-18GHz, there is not show in the report.		

Mark	Frequency (MHz)	Reading Level (dBμV)	Factor (dB)	Measure Level (dBμV/m)	Limit (dBμV/m)	Margin (dB)	Detector	Polarization
*	5666.5	50.6	4.7	55.3	90.5	-35.2	Peak	Horizontal
	7417.5	37.0	11.7	48.7	74.0	-25.3	Peak	Horizontal
*	9891.0	44.8	14.0	58.8	90.5	-31.7	Peak	Horizontal
	11319.0	42.8	19.2	62.0	74.0	-12.0	Peak	Horizontal
	11326.7	20.7	19.1	39.8	54.0	-14.2	Average	Horizontal
*	5666.5	59.8	4.7	64.5	90.5	-26.0	Peak	Vertical
	7416.8	32.5	11.7	44.2	54.0	-9.8	Average	Vertical
	7417.5	43.7	11.7	55.4	74.0	-18.6	Peak	Vertical
*	9891.0	49.3	14.0	63.3	90.5	-27.2	Peak	Vertical
	11319.0	46.1	19.2	65.3	74.0	-8.7	Peak	Vertical
	11324.5	22.0	19.1	41.1	54.0	-12.9	Average	Vertical

Note 1: "*" is not in restricted band, its limit is 30dBc of the fundamental emission level (120.5dBμV/m) or 15.209 which is higher.

Note 2: Measure Level (dBμV/m) = Reading Level (dBμV) + Factor (dB)

Factor (dB) = Cable Loss (dB) + Antenna Factor (dB/m) - Pre_Amplifier Gain (dB)

Product	2.4GHz HD Wireless Link	Temperature	26°C
Test Engineer	Snake Ni	Relative Humidity	56%
Test Site	AC2	Test Date	2019/04/19
Test Mode:	2.5MHz Bandwidth - Ant 1	Test Channel:	01
Remark:	1. Average measurement was not performed if peak level lower than average limit. 2. Other frequency was 20dB below limit line within 1-18GHz, there is not show in the report.		

Mark	Frequency (MHz)	Reading Level (dB μ V)	Factor (dB)	Measure Level (dB μ V/m)	Limit (dB μ V/m)	Margin (dB)	Detector	Polarization
	4825.0	50.1	3.6	53.7	74.0	-20.3	Peak	Horizontal
*	5607.0	55.5	4.5	60.0	99.9	-39.9	Peak	Horizontal
*	7230.5	53.3	11.5	64.8	99.9	-35.1	Peak	Horizontal
	12058.5	48.0	19.4	67.4	74.0	-6.6	Peak	Horizontal
	12060.1	24.7	19.4	44.1	54.0	-9.9	Average	Horizontal
	4823.9	46.5	3.6	50.1	54.0	-3.9	Average	Vertical
	4825.0	57.1	3.6	60.7	74.0	-13.3	Peak	Vertical
*	5607.0	62.8	4.5	67.3	99.9	-32.6	Peak	Vertical
*	7239.0	64.5	11.4	75.9	99.9	-24.0	Peak	Vertical
	12058.5	47.8	19.4	67.2	74.0	-6.8	Peak	Vertical
	12060.0	25.2	19.4	44.6	54.0	-9.4	Average	Vertical

Note 1: "*" is not in restricted band, its limit is 30dBc of the fundamental emission level (129.9dB μ V/m) or 15.209 which is higher.

Note 2: Measure Level (dB μ V/m) = Reading Level (dB μ V) + Factor (dB)

Factor (dB) = Cable Loss (dB) + Antenna Factor (dB/m) - Pre_Amplifier Gain (dB)

Product	2.4GHz HD Wireless Link	Temperature	26°C
Test Engineer	Snake Ni	Relative Humidity	56%
Test Site	AC2	Test Date	2019/04/19
Test Mode:	2.5MHz Bandwidth - Ant 1	Test Channel:	07
Remark:	1. Average measurement was not performed if peak level lower than average limit. 2. Other frequency was 20dB below limit line within 1-18GHz, there is not show in the report.		

Mark	Frequency (MHz)	Reading Level (dBµV)	Factor (dB)	Measure Level (dBµV/m)	Limit (dBµV/m)	Margin (dB)	Detector	Polarization
*	5607.0	54.7	4.5	59.2	99.6	-40.4	Peak	Horizontal
	7324.0	50.6	12.0	62.6	74.0	-11.4	Peak	Horizontal
	7325.8	30.5	11.9	42.4	54.0	-11.6	Average	Horizontal
*	9763.5	47.7	14.0	61.7	99.6	-37.9	Peak	Horizontal
	12209.7	20.6	19.5	40.1	54.0	-13.9	Average	Horizontal
	12211.5	39.5	19.4	58.9	74.0	-15.1	Peak	Horizontal
*	5607.0	63.1	4.5	67.6	99.6	-32.0	Peak	Vertical
	7324.0	60.9	12.0	72.9	74.0	-1.1	Peak	Vertical
	7325.9	39.9	11.9	51.8	54.0	-2.2	Average	Vertical
*	9772.0	49.0	14.0	63.0	99.6	-36.6	Peak	Vertical
	11202.4	27.1	18.9	46.0	54.0	-8.0	Average	Vertical
	11225.5	37.7	18.7	56.4	74.0	-17.6	Peak	Vertical

Note 1: "*" is not in restricted band, its limit is 30dBc of the fundamental emission level (129.6dBµV/m) or 15.209 which is higher.

Note 2: Measure Level (dBµV/m) = Reading Level (dBµV) + Factor (dB)

Factor (dB) = Cable Loss (dB) + Antenna Factor (dB/m) - Pre_Amplifier Gain (dB)

Product	2.4GHz HD Wireless Link	Temperature	26°C
Test Engineer	Snake Ni	Relative Humidity	56%
Test Site	AC2	Test Date	2019/04/19
Test Mode:	2.5MHz Bandwidth - Ant 1	Test Channel:	13
Remark:	1. Average measurement was not performed if peak level lower than average limit. 2. Other frequency was 20dB below limit line within 1-18GHz, there is not show in the report.		

Mark	Frequency (MHz)	Reading Level (dBμV)	Factor (dB)	Measure Level (dBμV/m)	Limit (dBμV/m)	Margin (dB)	Detector	Polarization
*	5598.5	54.8	4.4	59.2	98.6	-39.4	Peak	Horizontal
	7416.0	31.6	11.7	43.3	54.0	-10.7	Average	Horizontal
	7417.5	50.3	11.7	62.0	74.0	-12.0	Peak	Horizontal
*	9891.0	41.0	14.0	55.0	98.6	-43.6	Peak	Horizontal
	12359.6	20.4	19.5	39.9	54.0	-14.1	Average	Horizontal
	12364.5	40.7	19.5	60.2	74.0	-13.8	Peak	Horizontal
*	5598.5	63.2	4.4	67.6	98.6	-31.0	Peak	Vertical
	7416.0	39.8	11.7	51.5	54.0	-2.5	Average	Vertical
	7417.5	59.1	11.7	70.8	74.0	-3.2	Peak	Vertical
*	9891.0	52.2	14.0	66.2	98.6	-32.4	Peak	Vertical
	12359.6	21.1	19.5	40.6	54.0	-13.4	Average	Vertical
	12364.5	47.7	19.5	67.2	74.0	-6.8	Peak	Vertical

Note 1: "*" is not in restricted band, its limit is 30dBc of the fundamental emission level (128.6dBμV/m) or 15.209 which is higher.

Note 2: Measure Level (dBμV/m) = Reading Level (dBμV) + Factor (dB)

Factor (dB) = Cable Loss (dB) + Antenna Factor (dB/m) - Pre_Amplifier Gain (dB)

Product	2.4GHz HD Wireless Link	Temperature	26°C
Test Engineer	Snake Ni	Relative Humidity	56%
Test Site	AC2	Test Date	2019/04/19
Test Mode:	10MHz Bandwidth - Ant 2	Test Channel:	01
Remark:	1. Average measurement was not performed if peak level lower than average limit. 2. Other frequency was 20dB below limit line within 1-18GHz, there is not show in the report.		

Mark	Frequency (MHz)	Reading Level (dBμV)	Factor (dB)	Measure Level (dBμV/m)	Limit (dBμV/m)	Margin (dB)	Detector	Polarization
*	7239.0	49.7	11.4	61.1	90.6	-29.5	Peak	Horizontal
*	9644.5	43.6	13.7	57.3	90.6	-33.3	Peak	Horizontal
	11317.5	26.1	19.1	45.2	54.0	-8.8	Average	Horizontal
	11336.0	38.4	19.0	57.4	74.0	-16.6	Peak	Horizontal
	12065.4	20.1	19.5	39.6	54.0	-14.4	Average	Horizontal
	12067.0	38.0	19.5	57.5	74.0	-16.5	Peak	Horizontal
	4823.5	42.7	3.6	46.3	54.0	-7.7	Average	Vertical
	4825.0	52.4	3.6	56.0	74.0	-18.0	Peak	Vertical
*	7230.5	54.7	11.5	66.2	90.6	-24.4	Peak	Vertical
*	9644.5	54.0	13.7	67.7	90.6	-22.9	Peak	Vertical
	11317.0	28.9	19.1	48.0	54.0	-6.0	Average	Vertical
	11319.0	40.1	19.2	59.3	74.0	-14.7	Peak	Vertical

Note 1: "*" is not in restricted band, its limit is 30dBc of the fundamental emission level (120.6dBμV/m) or 15.209 which is higher.

Note 2: Measure Level (dBμV/m) = Reading Level (dBμV) + Factor (dB)

Factor (dB) = Cable Loss (dB) + Antenna Factor (dB/m) - Pre_Amplifier Gain (dB)

Product	2.4GHz HD Wireless Link	Temperature	26°C
Test Engineer	Snake Ni	Relative Humidity	56%
Test Site	AC2	Test Date	2019/04/19
Test Mode:	10MHz Bandwidth - Ant 2	Test Channel:	07
Remark:	1. Average measurement was not performed if peak level lower than average limit. 2. Other frequency was 20dB below limit line within 1-18GHz, there is not show in the report.		

Mark	Frequency (MHz)	Reading Level (dBμV)	Factor (dB)	Measure Level (dBμV/m)	Limit (dBμV/m)	Margin (dB)	Detector	Polarization
*	5675.0	48.7	4.9	53.6	95.4	-41.8	Peak	Horizontal
	7324.0	51.5	12.0	63.5	74.0	-10.5	Peak	Horizontal
	7324.2	32.7	12.0	44.7	54.0	-9.3	Average	Horizontal
*	9772.0	46.2	14.0	60.2	95.4	-35.2	Peak	Horizontal
	12210.8	20.1	19.4	39.5	54.0	-14.5	Average	Horizontal
	12211.5	40.6	19.4	60.0	74.0	-14.0	Peak	Horizontal
	4883.6	43.1	3.6	46.7	54.0	-7.3	Average	Vertical
	4884.5	54.0	3.5	57.5	74.0	-16.5	Peak	Vertical
*	5675.0	58.9	4.9	63.8	95.4	-31.6	Peak	Vertical
	7324.0	55.9	12.0	67.9	74.0	-6.1	Peak	Vertical
	7326.5	41.1	11.9	53.0	54.0	-1.0	Average	Vertical
*	9772.0	53.6	14.0	67.6	95.4	-27.8	Peak	Vertical

Note 1: "*" is not in restricted band, its limit is 30dBc of the fundamental emission level (125.4dBμV/m) or 15.209 which is higher.

Note 2: Measure Level (dBμV/m) = Reading Level (dBμV) + Factor (dB)

Factor (dB) = Cable Loss (dB) + Antenna Factor (dB/m) - Pre_Amplifier Gain (dB)

Product	2.4GHz HD Wireless Link	Temperature	26°C
Test Engineer	Snake Ni	Relative Humidity	56%
Test Site	AC2	Test Date	2019/04/19
Test Mode:	10MHz Bandwidth - Ant 2	Test Channel:	13
Remark:	1. Average measurement was not performed if peak level lower than average limit. 2. Other frequency was 20dB below limit line within 1-18GHz, there is not show in the report.		

Mark	Frequency (MHz)	Reading Level (dB μ V)	Factor (dB)	Measure Level (dB μ V/m)	Limit (dB μ V/m)	Margin (dB)	Detector	Polarization
	4944.0	41.6	3.5	45.1	74.0	-28.9	Peak	Horizontal
*	5666.5	49.3	4.7	54.0	88.1	-34.1	Peak	Horizontal
*	9891.0	44.9	14.0	58.9	88.1	-29.2	Peak	Horizontal
	11326.0	20.4	19.1	39.5	54.0	-14.5	Average	Horizontal
	11327.5	39.3	19.1	58.4	74.0	-15.6	Peak	Horizontal
*	5666.5	59.1	4.7	63.8	88.1	-24.3	Peak	Vertical
	7417.2	33.7	11.7	45.4	54.0	-8.6	Average	Vertical
	7417.5	46.8	11.7	58.5	74.0	-15.5	Peak	Vertical
*	9891.0	50.3	14.0	64.3	88.1	-23.8	Peak	Vertical
	11319.0	41.8	19.2	61.0	74.0	-13.0	Peak	Vertical
	11321.6	20.5	19.2	39.7	54.0	-14.3	Average	Vertical

Note 1: "*" is not in restricted band, its limit is 30dBc of the fundamental emission level (118.1dB μ V/m) or 15.209 which is higher.

Note 2: Measure Level (dB μ V/m) = Reading Level (dB μ V) + Factor (dB)

Factor (dB) = Cable Loss (dB) + Antenna Factor (dB/m) - Pre_Amplifier Gain (dB)

Product	2.4GHz HD Wireless Link	Temperature	26°C
Test Engineer	Snake Ni	Relative Humidity	56%
Test Site	AC2	Test Date	2019/04/23
Test Mode:	10MHz Bandwidth - Ant 2 (Model: IAUS11901c)	Test Channel:	07
Remark:	1. Average measurement was not performed if peak level lower than average limit. 2. Other frequency was 20dB below limit line within 1-18GHz, there is not show in the report.		

Mark	Frequency (MHz)	Reading Level (dBμV)	Factor (dB)	Measure Level (dBμV/m)	Limit (dBμV/m)	Margin (dB)	Detector	Polarization
*	5666.5	50.4	4.7	55.1	95.1	-40.0	Peak	Horizontal
	7324.0	50.9	12.0	62.9	74.0	-11.1	Peak	Horizontal
	7325.8	35.5	11.9	47.4	54.0	-6.6	Average	Horizontal
*	9772.0	47.1	14.0	61.1	95.1	-34.0	Peak	Horizontal
	11305.7	24.9	18.8	43.7	54.0	-10.3	Average	Horizontal
	11319.0	40.2	19.2	59.4	74.0	-14.6	Peak	Horizontal
*	5675.0	45.6	4.9	50.5	95.1	-44.6	Peak	Vertical
	7324.8	41.1	11.9	53.0	54.0	-1.0	Average	Vertical
	7332.5	50.7	11.8	62.5	74.0	-11.5	Peak	Vertical
*	9772.0	47.8	14.0	61.8	95.1	-33.3	Peak	Vertical
	12211.5	37.7	19.4	57.1	74.0	-16.9	Peak	Vertical

Note 1: "*" is not in restricted band, its limit is 30dBc of the fundamental emission level (125.1dBμV/m) or 15.209 which is higher.

Note 2: Measure Level (dBμV/m) = Reading Level (dBμV) + Factor (dB)

Factor (dB) = Cable Loss (dB) + Antenna Factor (dB/m) - Pre_Amplifier Gain (dB)

The worst case of Radiated Emission below 1GHz:

Site: AC2	Time: 2019/04/24 - 00:04
Limit: FCC_Part15.209_RSE(3m)	Engineer: Messiah Li
Probe: VULB 9168 _20-2000MHz	Polarity: Horizontal
EUT: 2.4GHz HD Wireless Link	Power: DC 5V
Test Mode: Worst mode	

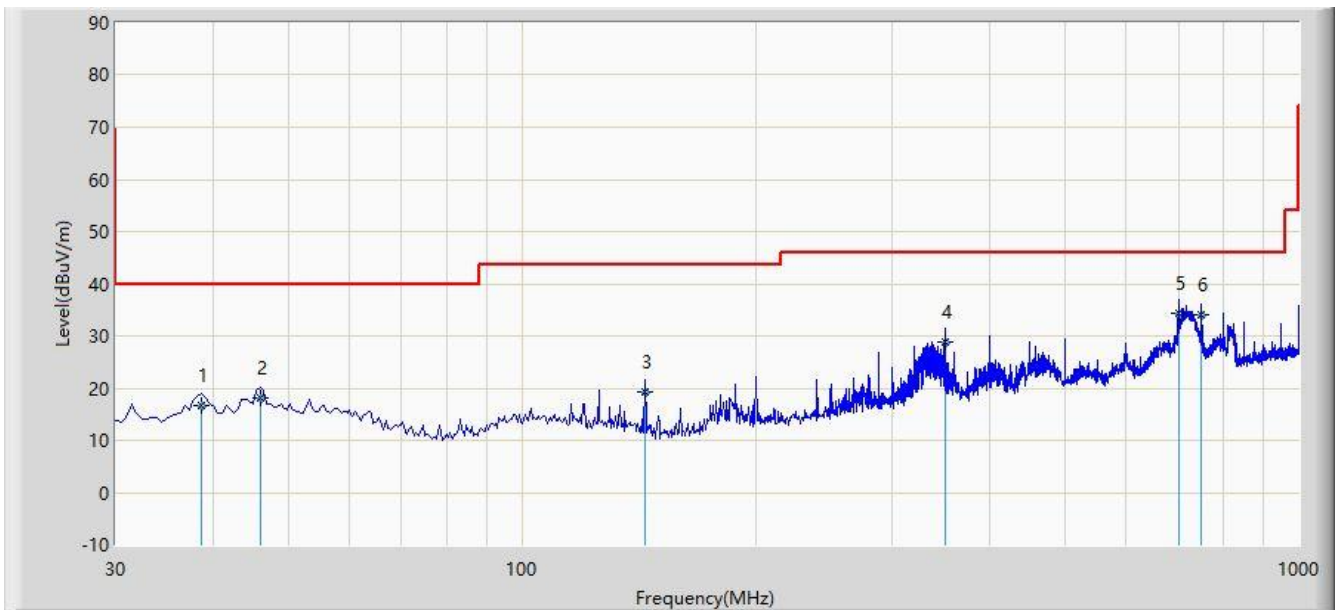

No	Flag	Mark	Frequency (MHz)	Measure Level (dBuV/m)	Reading Level (dBuV)	Over Limit (dB)	Limit (dBuV/m)	Factor (dB)	Type
1		*	38.760	16.793	3.240	-23.207	40.000	13.553	QP
2			46.056	18.155	3.250	-21.845	40.000	14.905	QP
3			143.900	19.409	10.120	-24.091	43.500	9.290	QP
4			350.260	28.978	13.410	-17.022	46.000	15.568	QP
5			700.120	34.408	13.250	-11.592	46.000	21.158	QP
6			749.740	34.097	12.320	-11.903	46.000	21.776	QP

Note 1: Measure Level (dB μ V/m) = Reading Level (dB μ V) + Factor (dB)

Factor (dB) = Cable Loss (dB) + Antenna Factor (dB/m)

Note 2: The test trace is same as the ambient noise and the amplitude of the emissions are attenuated more than 20dB below the permissible (the test frequency range: 9kHz ~ 30MHz, 18GHz ~ 25GHz), therefore no data appear in the report.

Site: AC2	Time: 2019/04/24 - 00:05
Limit: FCC_Part15.209_RSE(3m)	Engineer: Messiah Li
Probe: VULB 9168 _20-2000MHz	Polarity: Vertical
EUT: 2.4GHz HD Wireless Link	Power: DC 5V
Test Mode: Worst mode	

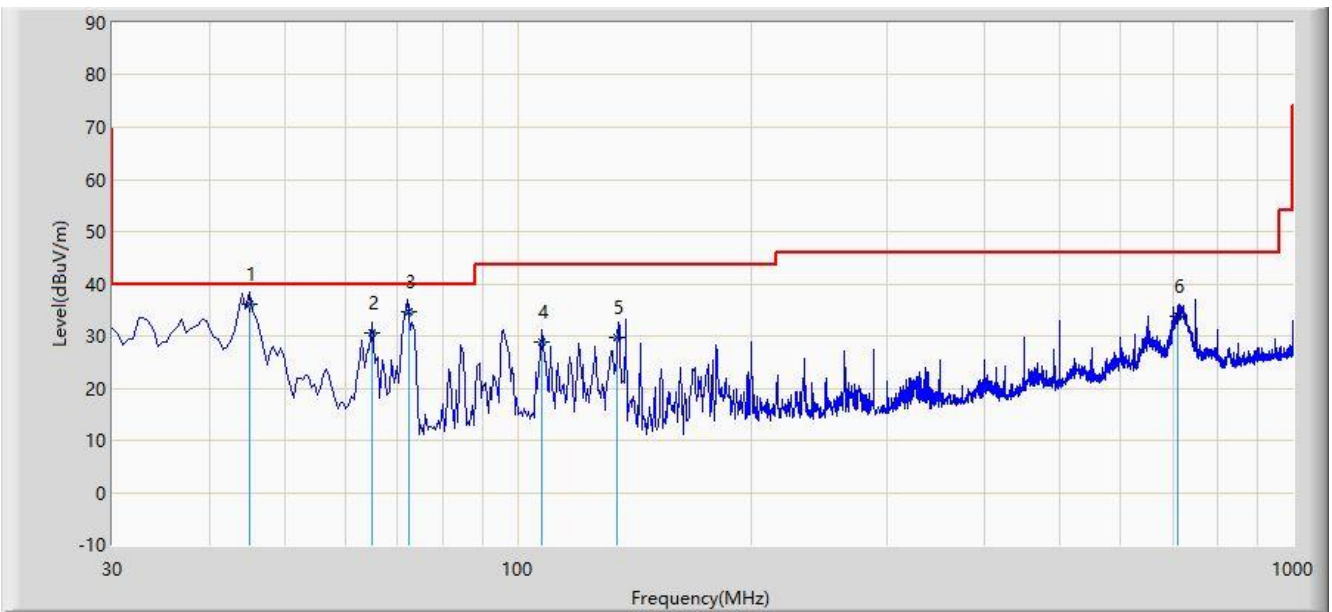

No	Flag	Mark	Frequency (MHz)	Measure Level (dBuV/m)	Reading Level (dBuV)	Over Limit (dB)	Limit (dBuV/m)	Factor (dB)	Type
1			45.010	35.978	21.250	-4.022	40.000	14.728	QP
2			64.950	30.575	18.120	-9.425	40.000	12.455	QP
3			72.510	34.558	24.350	-5.442	40.000	10.208	QP
4			107.240	28.934	16.030	-14.566	43.500	12.904	QP
5			134.210	29.717	20.120	-13.783	43.500	9.597	QP
6		*	710.260	33.653	12.350	-12.347	46.000	21.304	QP

Note 1: Measure Level (dB μ V/m) = Reading Level (dB μ V) + Factor (dB)

Factor (dB) = Cable Loss (dB) + Antenna Factor (dB/m)

Note 2: The test trace is same as the ambient noise and the amplitude of the emissions are attenuated more than 20dB below the permissible (the test frequency range: 9kHz ~ 30MHz, 18GHz ~ 25GHz), therefore no data appear in the report.

7.7. Radiated Restricted Band Edge Measurement

7.7.1. Test Limit

For 15.205 requirement:

Radiated emissions which fall in the restricted bands, as defined in Section 15.205(a) of FCC part 15, must also comply with the radiated emission limits specified in Section 15.209(a).

Frequency (MHz)	Frequency (MHz)	Frequency (MHz)	Frequency (GHz)
0.090 - 0.110	16.42 - 16.423	399.9 - 410	4.5 - 5.15
¹ 0.495 - 0.505	16.69475 - 16.69525	608 - 614	5.35 - 5.46
2.1735 - 2.1905	16.80425 - 16.80475	960 - 1240	7.25 - 7.75
4.125 - 4.128	25.5 - 25.67	1300 - 1427	8.025 - 8.5
4.17725 - 4.17775	37.5 - 38.25	1435 - 1626.5	9.0 - 9.2
4.20725 - 4.20775	73 - 74.6	1645.5 - 1646.5	9.3 - 9.5
6.215 - 6.218	74.8 - 75.2	1660 - 1710	10.6 - 12.7
6.26775 - 6.26825	108 - 121.94	1718.8 - 1722.2	13.25 - 13.4
6.31175 - 6.31225	123 - 138	2200 - 2300	14.47 - 14.5
8.291 - 8.294	149.9 - 150.05	2310 - 2390	15.35 - 16.2
8.362 - 8.366	156.52475 - 156.525	2483.5 - 2500	17.7 - 21.4
8.37625 - 8.38675	156.7 - 156.9	2690 - 2900	22.01 - 23.12
8.41425 - 8.41475	162.0125 - 167.17	3260 - 3267	23.6 - 24.0
12.29 - 12.293	167.72 - 173.2	3332 - 3339	31.2 - 31.8
12.51975 - 12.52025	240 - 285	3345.8 - 3358	36.43 - 36.5
12.57675 - 12.57725	322 - 335.4	3600 - 4400	(²)
13.36 - 13.41	--	--	--

All out of band emissions appearing in a restricted band as specified in Section 15.205 of the Title 47CFR must not exceed the limits shown in Table per Section 15.209.

FCC Part 15 Subpart C Paragraph 15.209		
Frequency [MHz]	Field Strength [uV/m]	Measured Distance [Meters]
0.009 - 0.490	2400/F (kHz)	300
0.490 - 1.705	24000/F (kHz)	30
1.705 - 30	30	30
30 - 88	100	3
88 - 216	150	3
216 - 960	200	3
Above 960	500	3

7.7.2. Test Procedure Used

ANSI C63.10 Section 6.3 (General Requirements)

ANSI C63.10 Section 6.6 (Standard test method above 1GHz)

7.7.3. Test Setting

Peak Field Strength Measurements

1. Analyzer center frequency was set to the frequency of the radiated spurious emission of interest
2. RBW = as specified in Table 1
3. VBW = 3MHz
4. Detector = peak
5. Sweep time = auto couple
6. Trace mode = max hold
7. Trace was allowed to stabilize

Average Field Strength Measurements

. Analyzer center frequency was set to the frequency of the radiated spurious emission of interest

2. RBW = 1MHz

3. VBW; If the EUT is configured to transmit with duty cycle $\geq 98\%$, set VBW = 10 Hz.

If the EUT duty cycle is $< 98\%$, set $VBW \geq 1/T$. T is the minimum transmission duration.

4. Detector = Peak

5. Sweep time = auto

6. Trace mode = max hold

7. Trace was allowed to stabilize

7.7.4. Test Setup

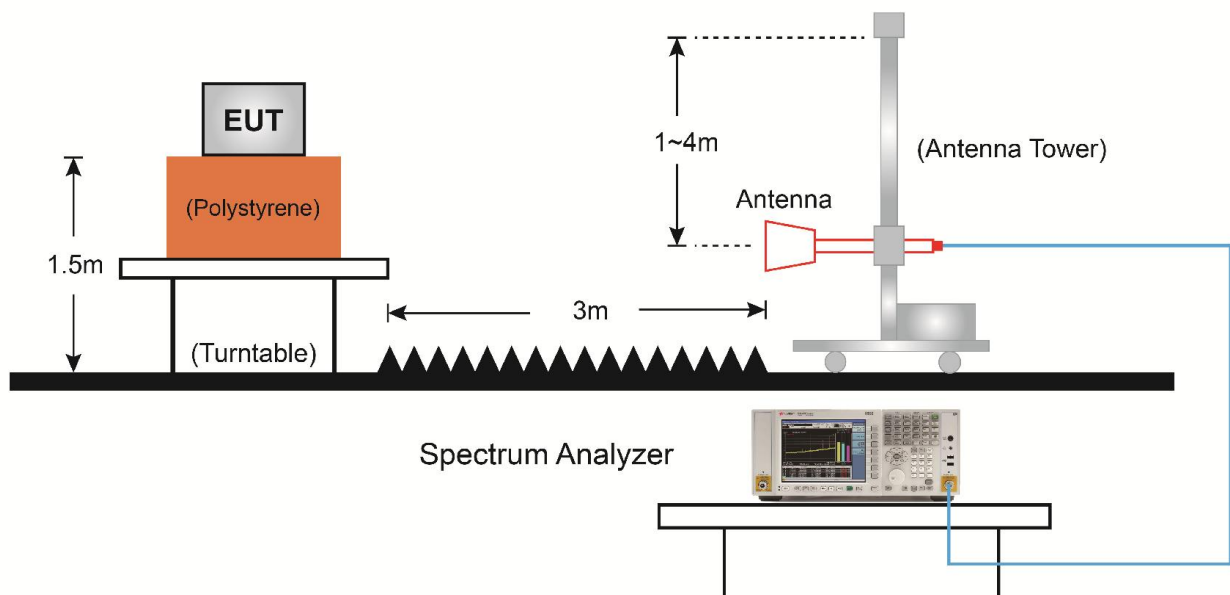

7.7.5. Test Result

Site: AC2	Time: 2019/04/19 - 22:27
Limit: FCC_Part15_Band Edge(3m)	Engineer: Snake Ni
Probe: BBHA9120D_1-18GHz	Polarity: Horizontal
EUT: 2.4GHz HD Wireless Link	Power: DC 5V
Test Mode: Transmit by 10MHz Bandwidth at channel 2412MHz with Ant 1	

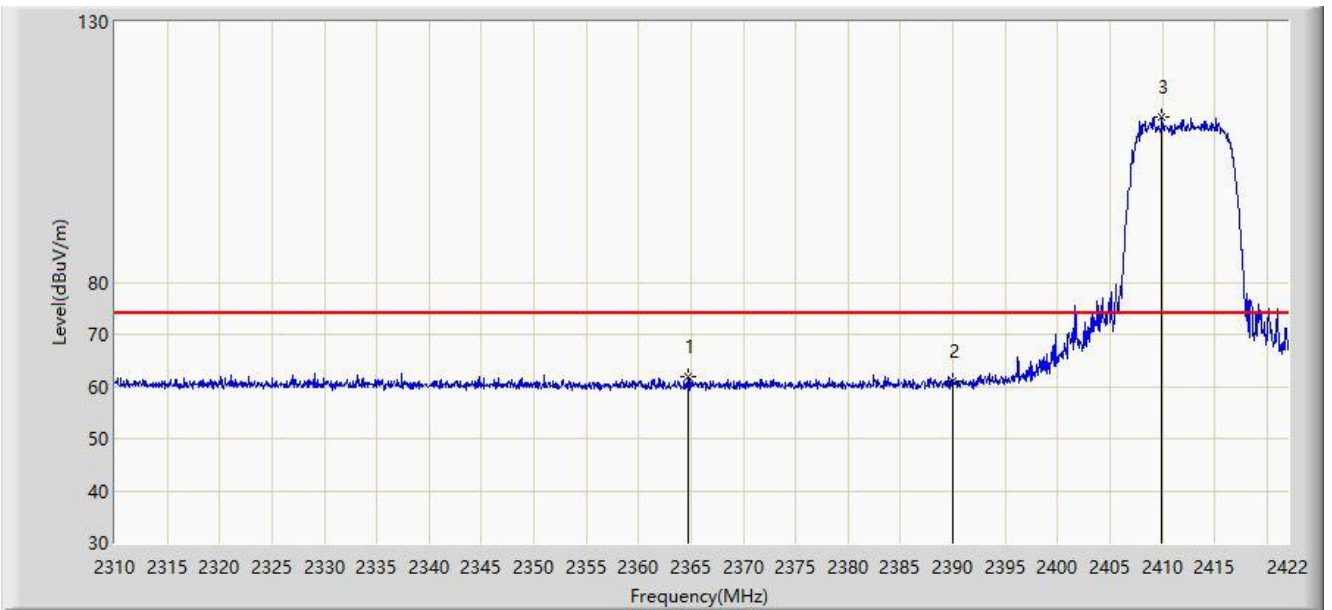

No	Flag	Mark	Frequency (MHz)	Measure Level (dBuV/m)	Reading Level (dBuV)	Over Limit (dB)	Limit (dBuV/m)	Factor (dB)	Type
1			2364.768	61.926	30.460	-12.074	74.000	31.466	PK
2			2390.000	60.948	29.499	-13.052	74.000	31.449	PK
3		*	2409.960	111.625	80.231	N/A	N/A	31.394	PK

Note: Measure Level (dB μ V/m) = Reading Level (dB μ V) + Factor (dB)

Factor (dB) = Cable Loss (dB) + Antenna Factor (dB/m).

Site: AC2	Time: 2019/04/19 - 22:28
Limit: FCC_Part15_Band Edge(3m)	Engineer: Snake Ni
Probe: BBHA9120D_1-18GHz	Polarity: Horizontal
EUT: 2.4GHz HD Wireless Link	Power: DC 5V
Test Mode: Transmit by 10MHz Bandwidth at channel 2412MHz with Ant 1	

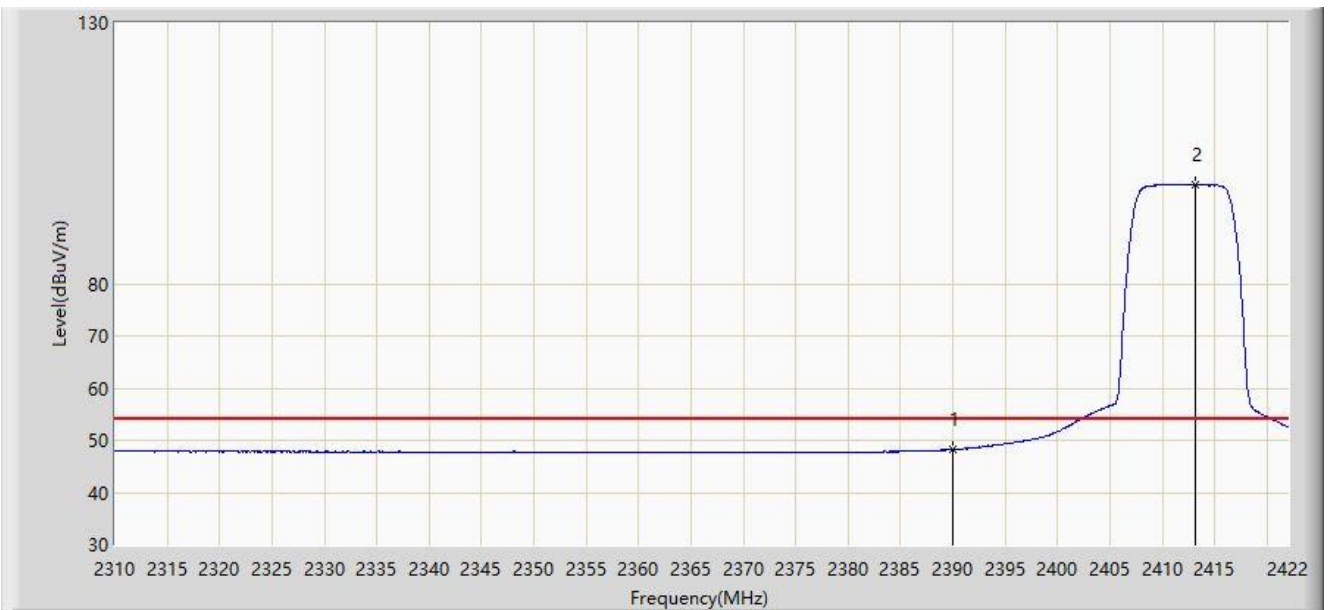

No	Flag	Mark	Frequency (MHz)	Measure Level (dBuV/m)	Reading Level (dBuV)	Over Limit (dB)	Limit (dBuV/m)	Factor (dB)	Type
1			2390.000	48.245	16.796	-5.755	54.000	31.449	AV
2		*	2413.208	99.102	67.717	N/A	N/A	31.385	AV

Note: Measure Level (dBuV/m) = Reading Level (dBuV) + Factor (dB)

Factor (dB) = Cable Loss (dB) + Antenna Factor (dB/m).

Site: AC2	Time: 2019/04/19 - 22:29
Limit: FCC_Part15_Band Edge(3m)	Engineer: Snake Ni
Probe: BBHA9120D_1-18GHz	Polarity: Vertical
EUT: 2.4GHz HD Wireless Link	Power: DC 5V
Test Mode: Transmit by 10MHz Bandwidth at channel 2412MHz with Ant 1	

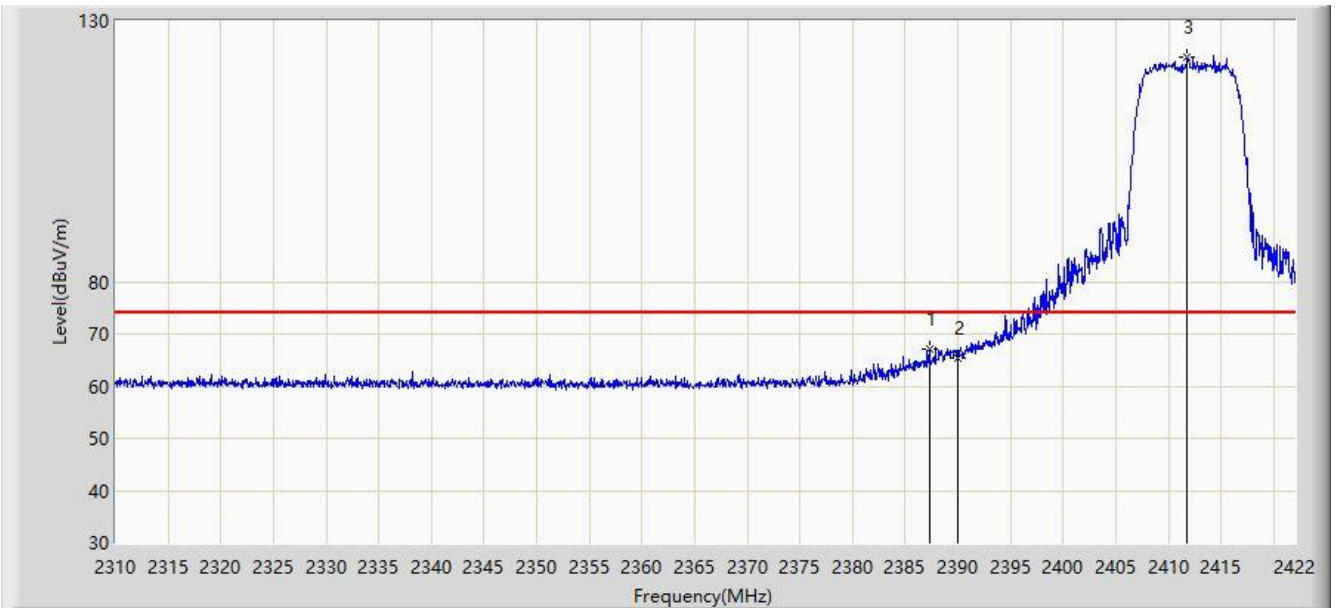

No	Flag	Mark	Frequency (MHz)	Measure Level (dBuV/m)	Reading Level (dBuV)	Over Limit (dB)	Limit (dBuV/m)	Factor (dB)	Type
1			2387.336	67.126	35.678	-6.874	74.000	31.449	PK
2			2390.000	65.498	34.049	-8.502	74.000	31.449	PK
3		*	2411.808	123.144	91.756	N/A	N/A	31.388	PK

Note: Measure Level (dB μ V/m) = Reading Level (dB μ V) + Factor (dB)

Factor (dB) = Cable Loss (dB) + Antenna Factor (dB/m).

Site: AC2	Time: 2019/04/19 - 22:30
Limit: FCC_Part15_Band Edge(3m)	Engineer: Snake Ni
Probe: BBHA9120D_1-18GHz	Polarity: Vertical
EUT: 2.4GHz HD Wireless Link	Power: DC 5V
Test Mode: Transmit by 10MHz Bandwidth at channel 2412MHz with Ant 1	

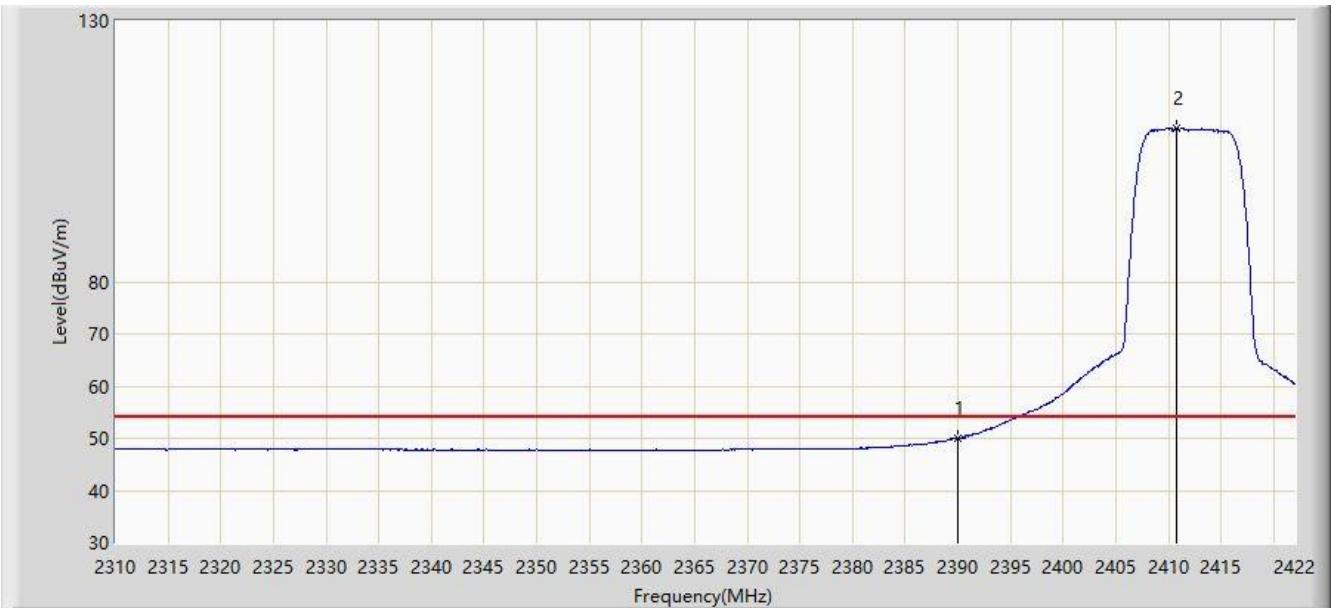

No	Flag	Mark	Frequency (MHz)	Measure Level (dBuV/m)	Reading Level (dBuV)	Over Limit (dB)	Limit (dBuV/m)	Factor (dB)	Type
1			2390.000	49.906	18.457	-4.094	54.000	31.449	AV
2		*	2410.800	109.429	78.038	N/A	N/A	31.391	AV

Note: Measure Level (dBuV/m) = Reading Level (dBuV) + Factor (dB)

Factor (dB) = Cable Loss (dB) + Antenna Factor (dB/m).

Site: AC2	Time: 2019/04/19 - 22:38
Limit: FCC_Part15_Band Edge(3m)	Engineer: Snake Ni
Probe: BBHA9120D_1-18GHz	Polarity: Horizontal
EUT: 2.4GHz HD Wireless Link	Power: DC 5V
Test Mode: Transmit by 10MHz Bandwidth at channel 2472MHz with Ant 1	

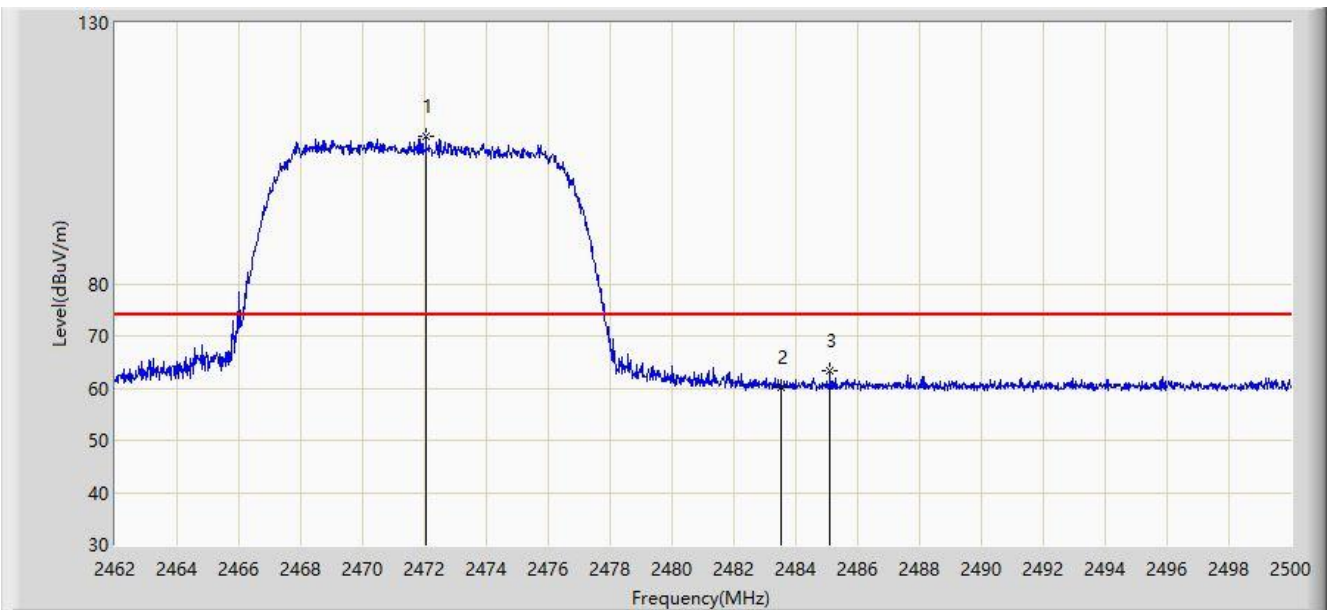

No	Flag	Mark	Frequency (MHz)	Measure Level (dBuV/m)	Reading Level (dBuV)	Over Limit (dB)	Limit (dBuV/m)	Factor (dB)	Type
1		*	2472.051	108.156	76.786	N/A	N/A	31.370	PK
2			2483.500	60.142	28.739	-13.858	74.000	31.403	PK
3			2485.104	63.388	31.980	-10.612	74.000	31.409	PK

Note: Measure Level (dB μ V/m) = Reading Level (dB μ V) + Factor (dB)

Factor (dB) = Cable Loss (dB) + Antenna Factor (dB/m).

Site: AC2	Time: 2019/04/19 - 22:39
Limit: FCC_Part15_Band Edge(3m)	Engineer: Snake Ni
Probe: BBHA9120D_1-18GHz	Polarity: Horizontal
EUT: 2.4GHz HD Wireless Link	Power: DC 5V
Test Mode: Transmit by 10MHz Bandwidth at channel 2472MHz with Ant 1	

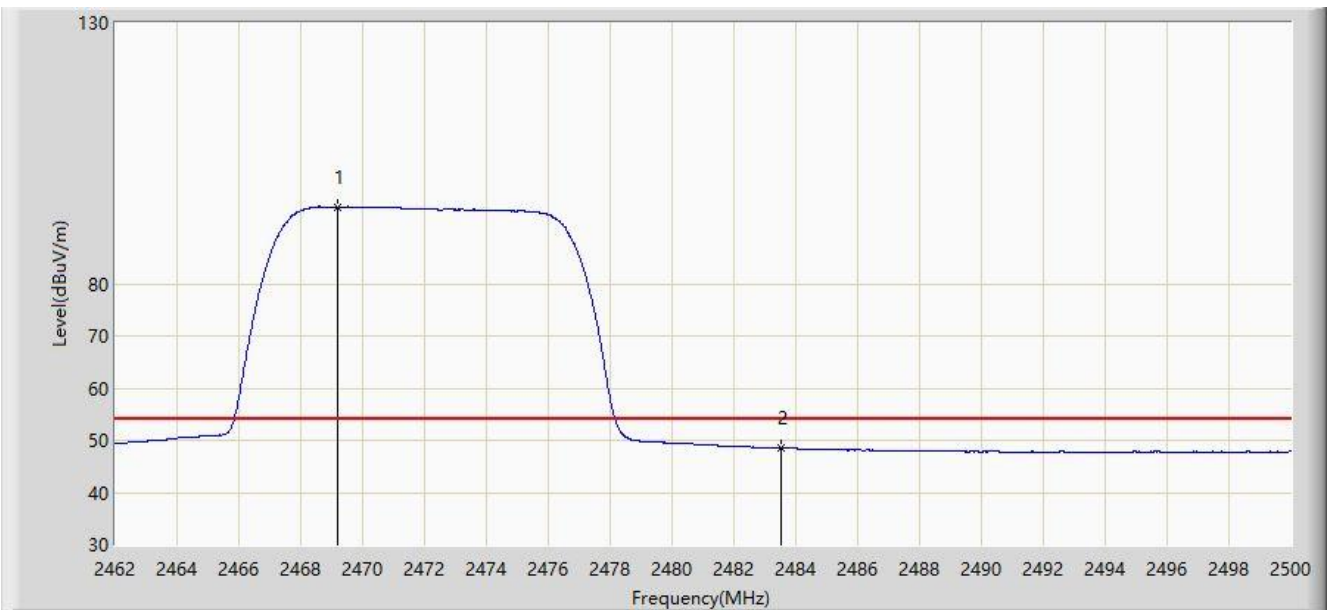

No	Flag	Mark	Frequency (MHz)	Measure Level (dBuV/m)	Reading Level (dBuV)	Over Limit (dB)	Limit (dBuV/m)	Factor (dB)	Type
1		*	2469.182	94.763	63.400	N/A	N/A	31.363	AV
2			2483.500	48.502	17.099	-5.498	54.000	31.403	AV

Note: Measure Level (dB μ V/m) = Reading Level (dB μ V) + Factor (dB)

Factor (dB) = Cable Loss (dB) + Antenna Factor (dB/m).

Site: AC2	Time: 2019/04/19 - 22:35
Limit: FCC_Part15_Band Edge(3m)	Engineer: Snake Ni
Probe: BBHA9120D_1-18GHz	Polarity: Vertical
EUT: 2.4GHz HD Wireless Link	Power: DC 5V
Test Mode: Transmit by 10MHz Bandwidth at channel 2472MHz with Ant 1	

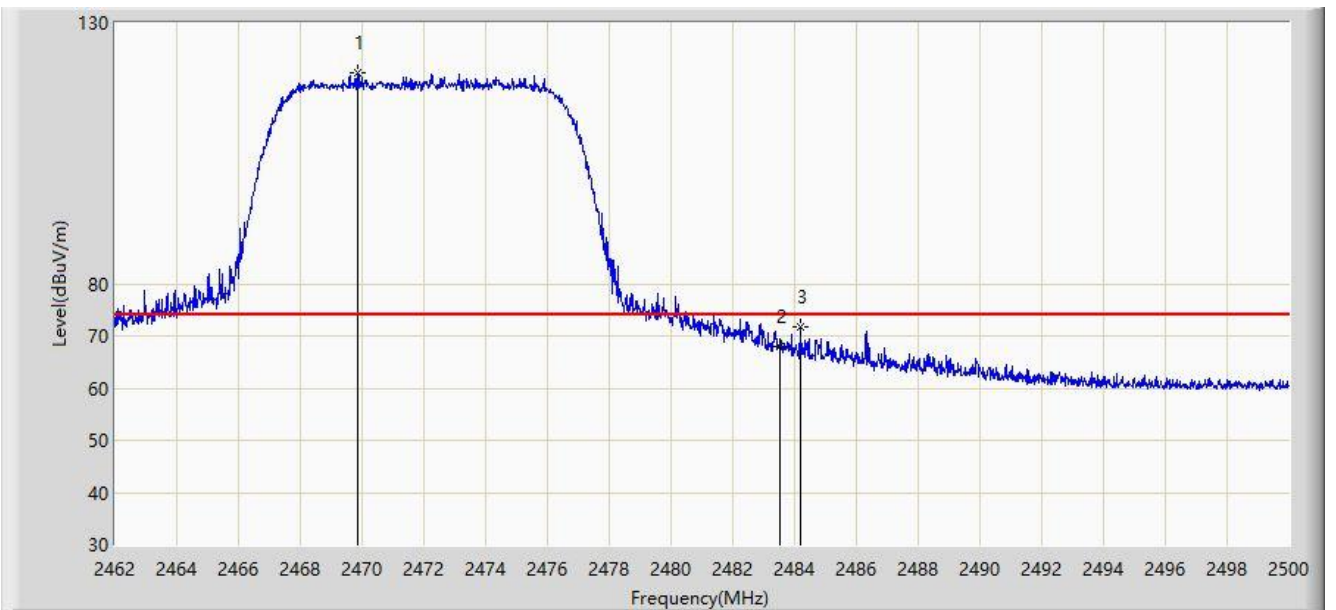

No	Flag	Mark	Frequency (MHz)	Measure Level (dBuV/m)	Reading Level (dBuV)	Over Limit (dB)	Limit (dBuV/m)	Factor (dB)	Type
1		*	2469.847	120.520	89.156	N/A	N/A	31.365	PK
2			2483.500	68.010	36.607	-5.990	74.000	31.403	PK
3			2484.173	71.717	40.312	-2.283	74.000	31.405	PK

Note: Measure Level (dBuV/m) = Reading Level (dBuV) + Factor (dB)

Factor (dB) = Cable Loss (dB) + Antenna Factor (dB/m).

Site: AC2	Time: 2019/04/19 - 22:37
Limit: FCC_Part15_Band Edge(3m)	Engineer: Snake Ni
Probe: BBHA9120D_1-18GHz	Polarity: Vertical
EUT: 2.4GHz HD Wireless Link	Power: DC 5V
Test Mode: Transmit by 10MHz Bandwidth at channel 2472MHz with Ant 1	

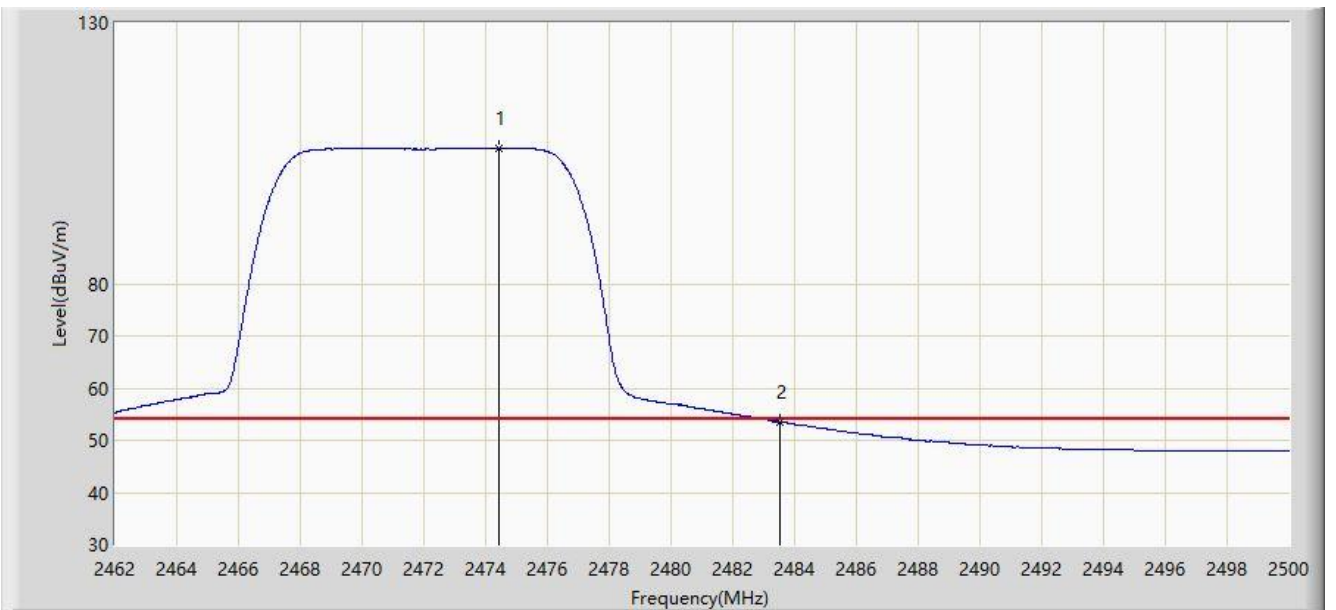

No	Flag	Mark	Frequency (MHz)	Measure Level (dBuV/m)	Reading Level (dBuV)	Over Limit (dB)	Limit (dBuV/m)	Factor (dB)	Type
1		*	2474.445	105.946	74.570	N/A	N/A	31.376	AV
2			2483.500	53.483	22.080	-0.517	54.000	31.403	AV

Note: Measure Level (dBuV/m) = Reading Level (dBuV) + Factor (dB)

Factor (dB) = Cable Loss (dB) + Antenna Factor (dB/m).

Site: AC2	Time: 2019/04/13 - 11:28
Limit: FCC_Part15_Band Edge(3m)	Engineer: Messiah Li
Probe: BBHA9120D_1-18GHz	Polarity: Horizontal
EUT: 2.4GHz HD Wireless Link	Power: DC 5V
Test Mode: Transmit by 2.5MHz Bandwidth at channel 2412MHz with Ant 1	

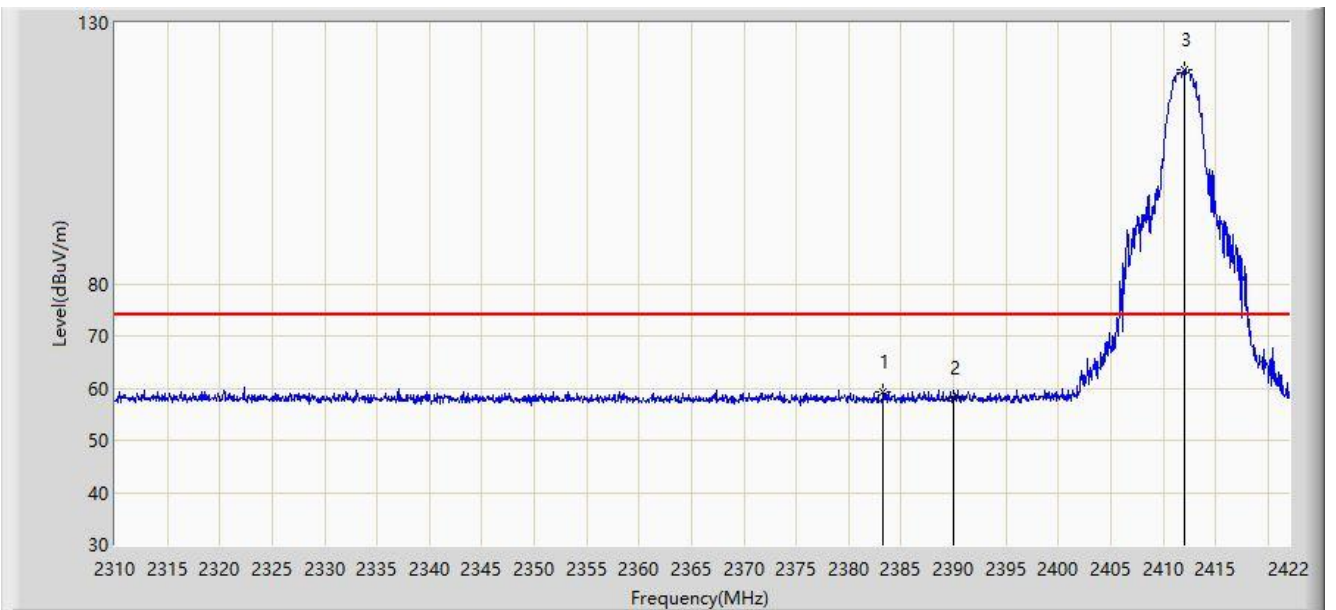

No	Flag	Mark	Frequency (MHz)	Measure Level (dBuV/m)	Reading Level (dBuV)	Over Limit (dB)	Limit (dBuV/m)	Factor (dB)	Type
1			2383.304	59.352	27.904	-14.648	74.000	31.447	PK
2			2390.000	58.258	26.809	-15.742	74.000	31.449	PK
3		*	2411.976	121.079	89.691	N/A	N/A	31.388	PK

Note: Measure Level (dB μ V/m) = Reading Level (dB μ V) + Factor (dB)

Factor (dB) = Cable Loss (dB) + Antenna Factor (dB/m).

Site: AC2	Time: 2019/04/13 - 11:34
Limit: FCC_Part15_Band Edge(3m)	Engineer: Messiah Li
Probe: BBHA9120D_1-18GHz	Polarity: Horizontal
EUT: 2.4GHz HD Wireless Link	Power: DC 5V
Test Mode: Transmit by 2.5MHz Bandwidth at channel 2412MHz with Ant 1	

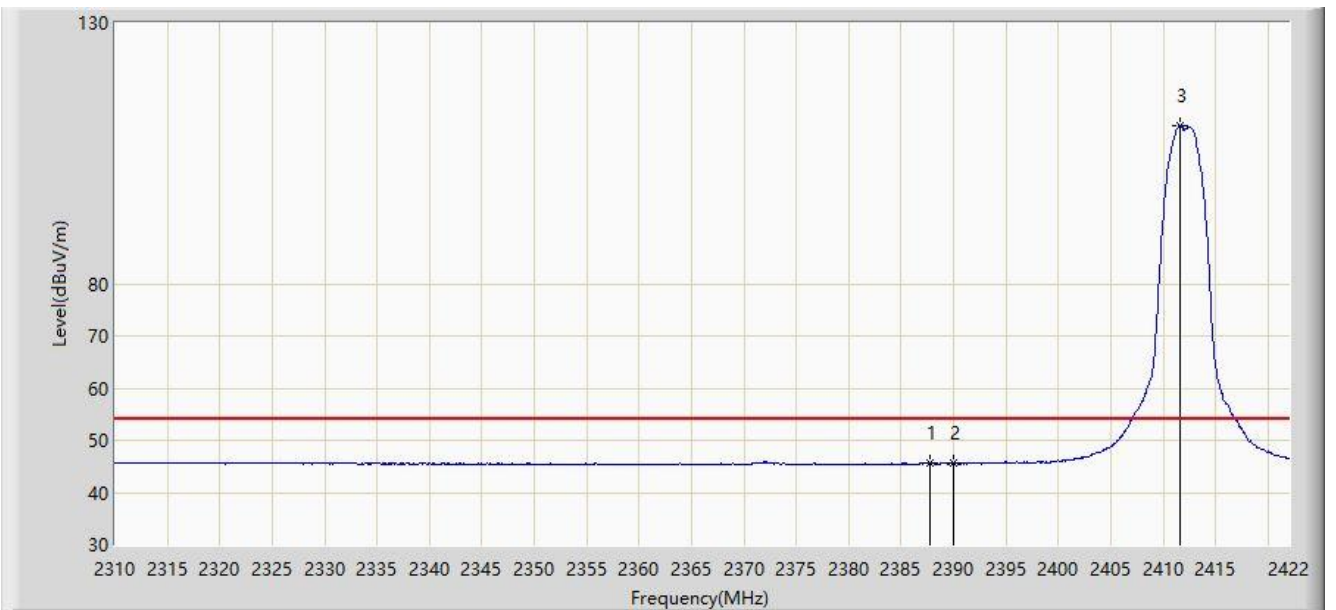

No	Flag	Mark	Frequency (MHz)	Measure Level (dBuV/m)	Reading Level (dBuV)	Over Limit (dB)	Limit (dBuV/m)	Factor (dB)	Type
1			2387.784	45.699	14.251	-8.301	54.000	31.449	AV
2			2390.000	45.561	14.112	-8.439	54.000	31.449	AV
3		*	2411.640	110.386	78.997	N/A	N/A	31.389	AV

Note: Measure Level (dB μ V/m) = Reading Level (dB μ V) + Factor (dB)

Factor (dB) = Cable Loss (dB) + Antenna Factor (dB/m).

Site: AC2	Time: 2019/04/13 - 11:55
Limit: FCC_Part15_Band Edge(3m)	Engineer: Messiah Li
Probe: BBHA9120D_1-18GHz	Polarity: Vertical
EUT: 2.4GHz HD Wireless Link	Power: DC 5V
Test Mode: Transmit by 2.5MHz Bandwidth at channel 2412MHz with Ant 1	

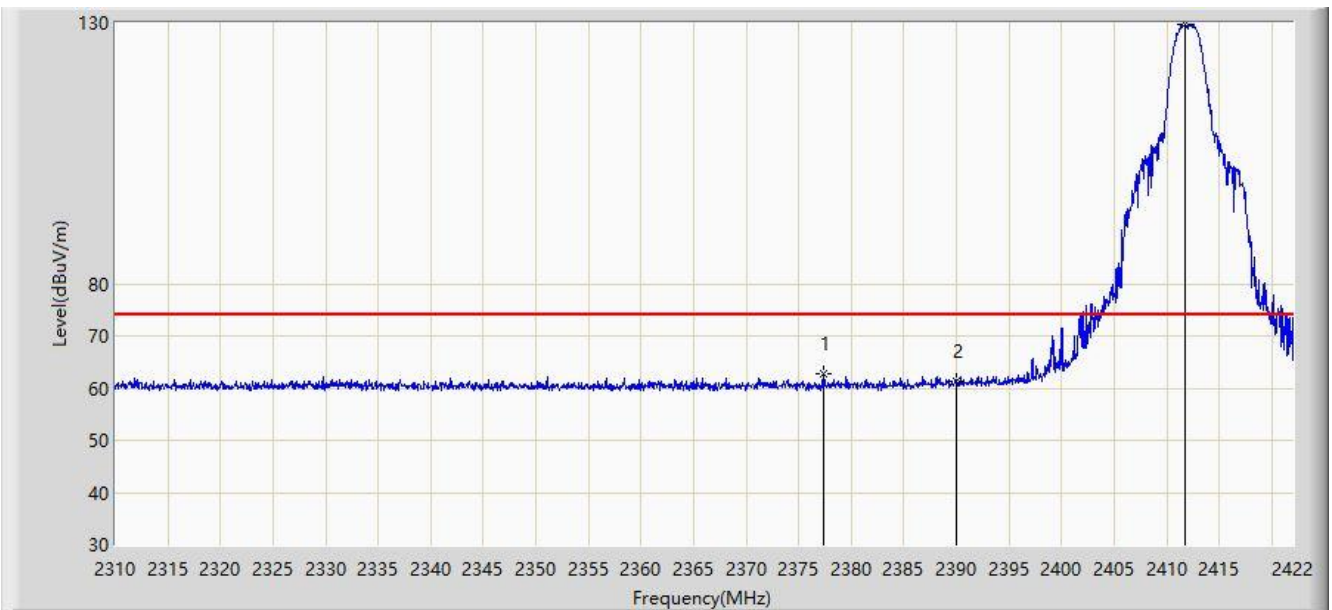

No	Flag	Mark	Frequency (MHz)	Measure Level (dBuV/m)	Reading Level (dBuV)	Over Limit (dB)	Limit (dBuV/m)	Factor (dB)	Type
1			2377.424	62.744	31.297	-11.256	74.000	31.446	PK
2			2390.000	61.364	29.915	-12.636	74.000	31.449	PK
3		*	2411.752	129.853	98.464	N/A	N/A	31.389	PK

Note: Measure Level (dBuV/m) = Reading Level (dBuV) + Factor (dB)

Factor (dB) = Cable Loss (dB) + Antenna Factor (dB/m).

Site: AC2	Time: 2019/04/13 - 11:58
Limit: FCC_Part15_Band Edge(3m)	Engineer: Messiah Li
Probe: BBHA9120D_1-18GHz	Polarity: Vertical
EUT: 2.4GHz HD Wireless Link	Power: DC 5V
Test Mode: Transmit by 2.5MHz Bandwidth at channel 2412MHz with Ant 1	

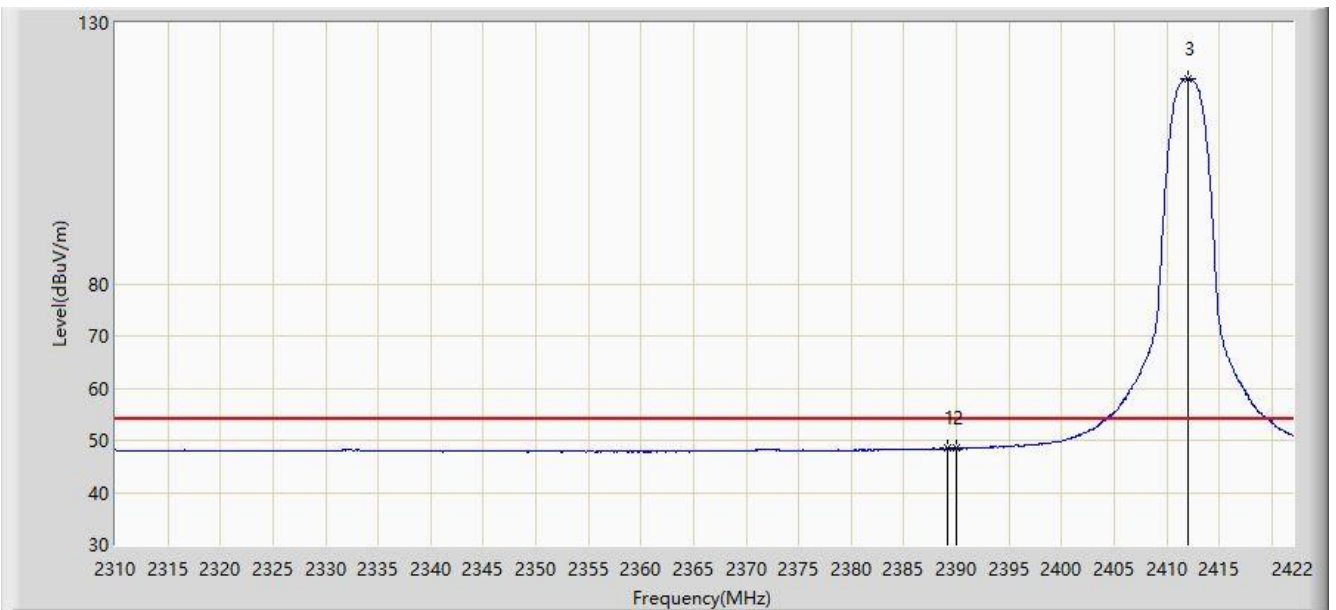

No	Flag	Mark	Frequency (MHz)	Measure Level (dBuV/m)	Reading Level (dBuV)	Over Limit (dB)	Limit (dBuV/m)	Factor (dB)	Type
1			2389.184	48.537	17.088	-5.463	54.000	31.449	AV
2			2390.000	48.411	16.962	-5.589	54.000	31.449	AV
3		*	2412.032	119.154	87.766	N/A	N/A	31.388	AV

Note: Measure Level (dB μ V/m) = Reading Level (dB μ V) + Factor (dB)

Factor (dB) = Cable Loss (dB) + Antenna Factor (dB/m).

Site: AC2	Time: 2019/04/13 - 12:20
Limit: FCC_Part15_Band Edge(3m)	Engineer: Messiah Li
Probe: BBHA9120D_1-18GHz	Polarity: Horizontal
EUT: 2.4GHz HD Wireless Link	Power: DC 5V
Test Mode: Transmit by 2.5MHz Bandwidth at channel 2472MHz with Ant 1	

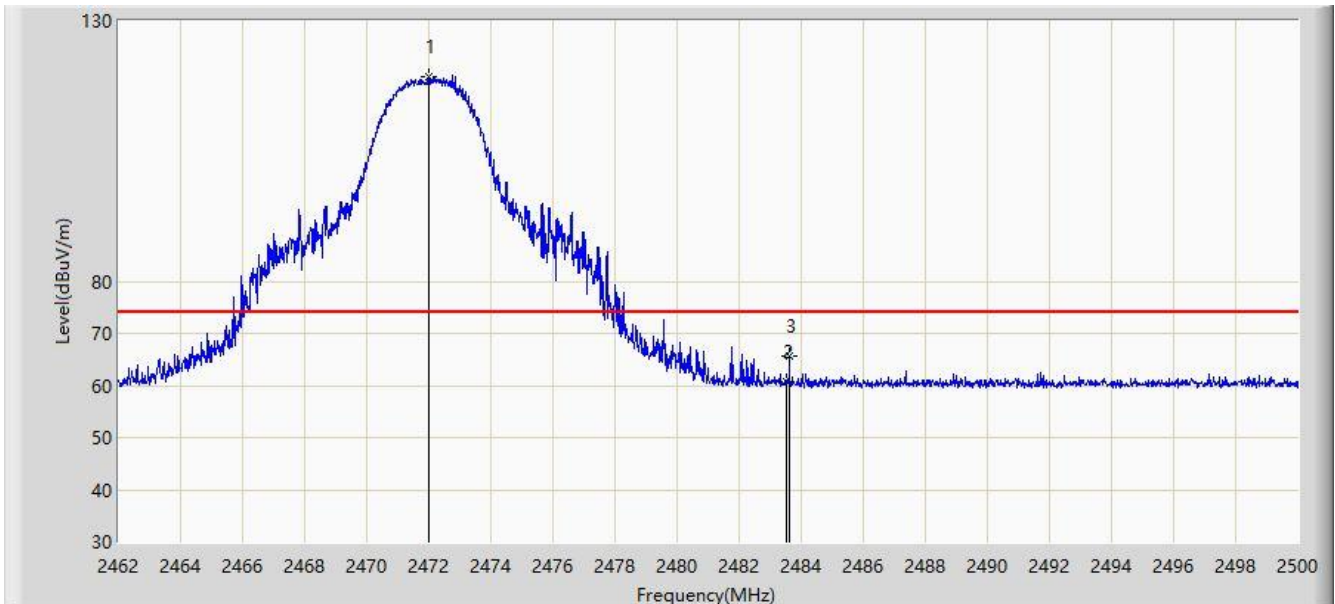

No	Flag	Mark	Frequency (MHz)	Measure Level (dBuV/m)	Reading Level (dBuV)	Over Limit (dB)	Limit (dBuV/m)	Factor (dB)	Type
1		*	2471.994	119.319	87.949	N/A	N/A	31.370	PK
2			2483.500	60.740	29.337	-13.260	74.000	31.403	PK
3			2483.622	65.639	34.236	-8.361	74.000	31.403	PK

Note: Measure Level (dB μ V/m) = Reading Level (dB μ V) + Factor (dB)

Factor (dB) = Cable Loss (dB) + Antenna Factor (dB/m).

Site: AC2	Time: 2019/04/13 - 12:22
Limit: FCC_Part15_Band Edge(3m)	Engineer: Messiah Li
Probe: BBHA9120D_1-18GHz	Polarity: Horizontal
EUT: 2.4GHz HD Wireless Link	Power: DC 5V
Test Mode: Transmit by 2.5MHz Bandwidth at channel 2472MHz with Ant 1	

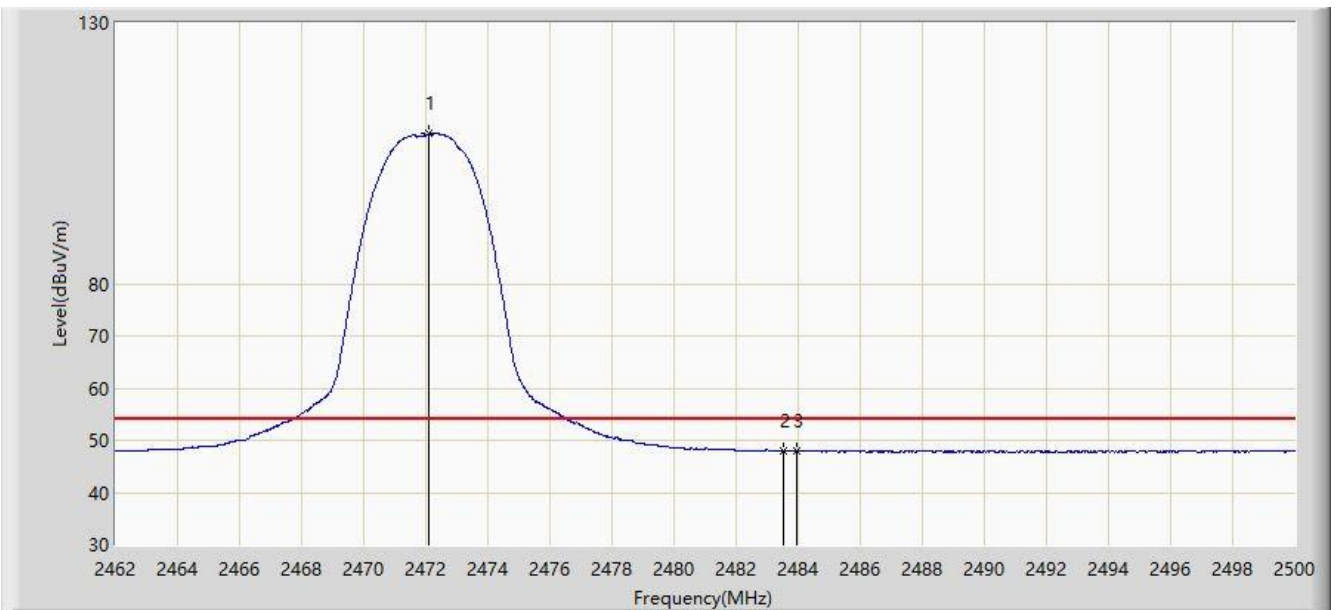

No	Flag	Mark	Frequency (MHz)	Measure Level (dBuV/m)	Reading Level (dBuV)	Over Limit (dB)	Limit (dBuV/m)	Factor (dB)	Type
1		*	2472.108	108.764	77.394	N/A	N/A	31.370	AV
2			2483.500	47.962	16.559	-6.038	54.000	31.403	AV
3			2483.964	47.995	16.591	-6.005	54.000	31.404	AV

Note: Measure Level (dB μ V/m) = Reading Level (dB μ V) + Factor (dB)

Factor (dB) = Cable Loss (dB) + Antenna Factor (dB/m).

Site: AC2	Time: 2019/04/13 - 12:16
Limit: FCC_Part15_Band Edge(3m)	Engineer: Messiah Li
Probe: BBHA9120D_1-18GHz	Polarity: Vertical
EUT: 2.4GHz HD Wireless Link	Power: DC 5V
Test Mode: Transmit by 2.5MHz Bandwidth at channel 2472MHz with Ant 1	

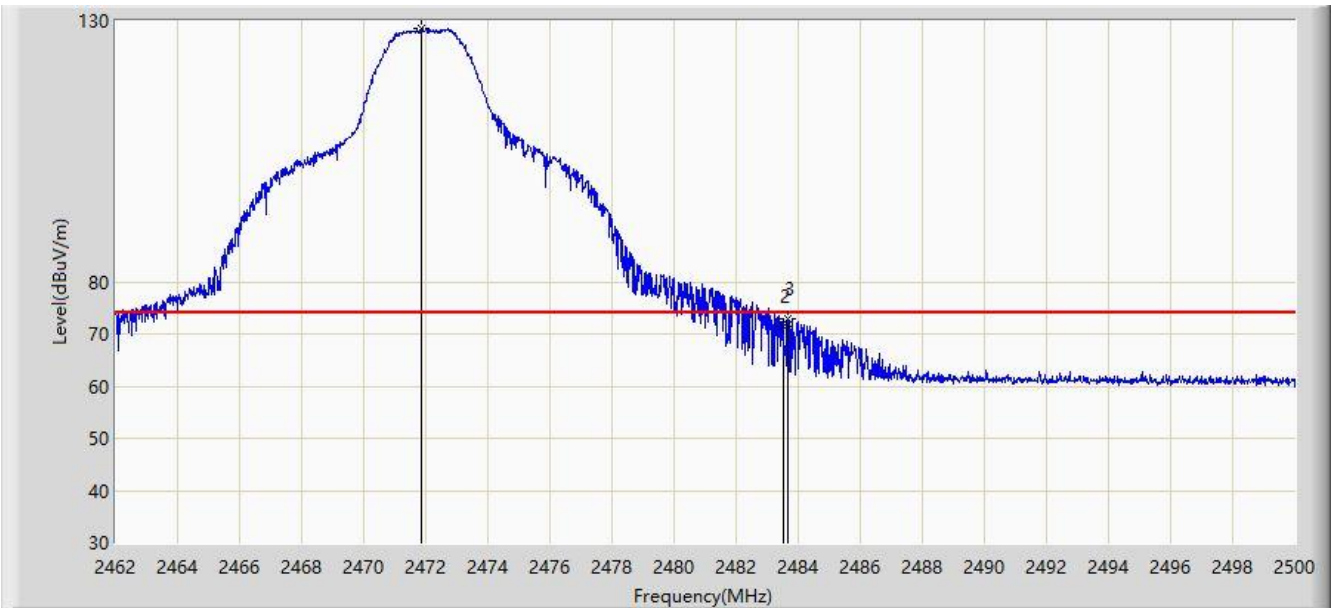

No	Flag	Mark	Frequency (MHz)	Measure Level (dBuV/m)	Reading Level (dBuV)	Over Limit (dB)	Limit (dBuV/m)	Factor (dB)	Type
1		*	2471.842	128.647	97.278	N/A	N/A	31.370	PK
2			2483.500	71.307	39.904	-2.693	74.000	31.403	PK
3			2483.660	72.762	41.359	-1.238	74.000	31.403	PK

Note: Measure Level (dB μ V/m) = Reading Level (dB μ V) + Factor (dB)

Factor (dB) = Cable Loss (dB) + Antenna Factor (dB/m).

Site: AC2	Time: 2019/04/13 - 12:19
Limit: FCC_Part15_Band Edge(3m)	Engineer: Messiah Li
Probe: BBHA9120D_1-18GHz	Polarity: Vertical
EUT: 2.4GHz HD Wireless Link	Power: DC 5V
Test Mode: Transmit by 2.5MHz Bandwidth at channel 2472MHz with Ant 1	

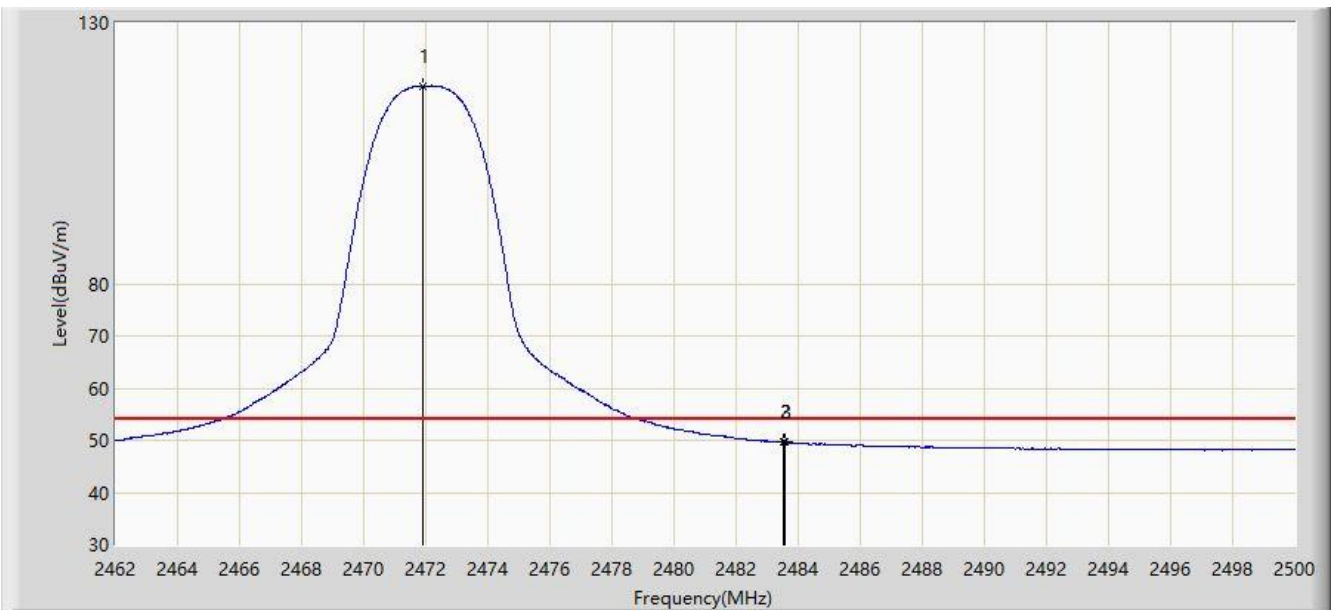

No	Flag	Mark	Frequency (MHz)	Measure Level (dBuV/m)	Reading Level (dBuV)	Over Limit (dB)	Limit (dBuV/m)	Factor (dB)	Type
1		*	2471.899	117.932	86.562	N/A	N/A	31.370	AV
2			2483.500	49.576	18.173	-4.424	54.000	31.403	AV
3			2483.565	49.586	18.183	-4.414	54.000	31.403	AV

Note: Measure Level (dB μ V/m) = Reading Level (dB μ V) + Factor (dB)

Factor (dB) = Cable Loss (dB) + Antenna Factor (dB/m).

Site: AC2	Time: 2019/04/19 - 20:40
Limit: FCC_Part15_Band Edge(3m)	Engineer: Snake Ni
Probe: BBHA9120D_1-18GHz	Polarity: Horizontal
EUT: 2.4GHz HD Wireless Link	Power: DC 5V
Test Mode: Transmit by 10MHz Bandwidth at channel 2412MHz with Ant 2	

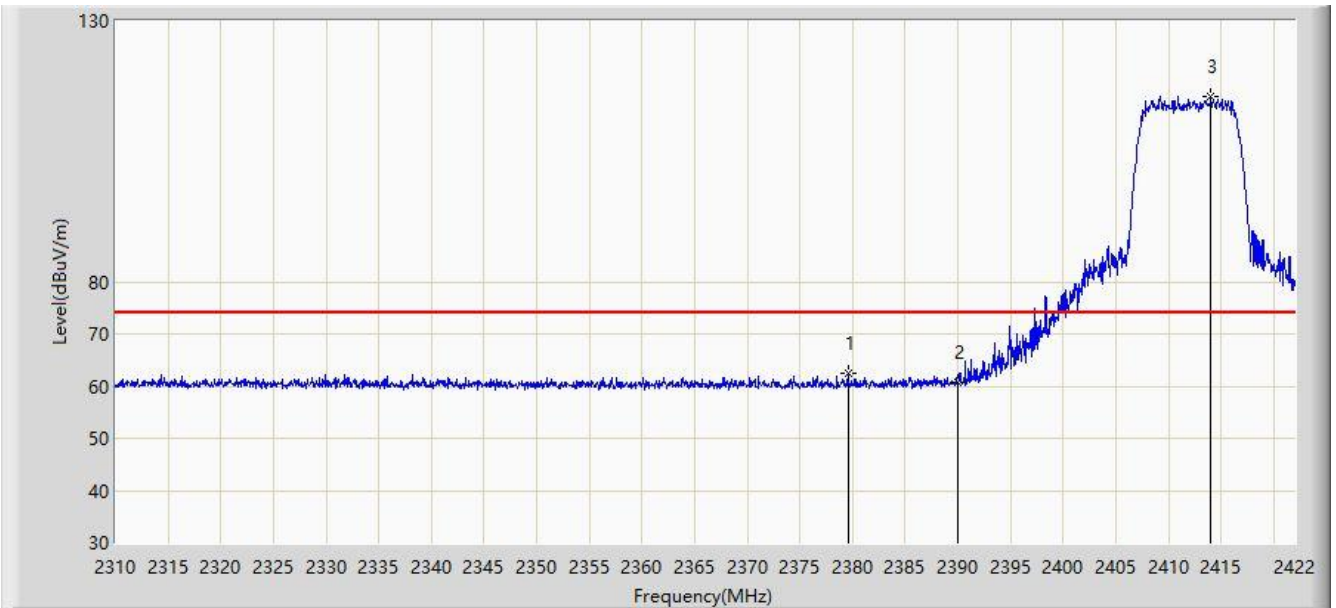

No	Flag	Mark	Frequency (MHz)	Measure Level (dBuV/m)	Reading Level (dBuV)	Over Limit (dB)	Limit (dBuV/m)	Factor (dB)	Type
1			2379.552	62.346	30.899	-11.654	74.000	31.447	PK
2			2390.000	60.668	29.219	-13.332	74.000	31.449	PK
3		*	2414.048	115.569	84.186	N/A	N/A	31.383	PK

Note: Measure Level (dB μ V/m) = Reading Level (dB μ V) + Factor (dB)

Factor (dB) = Cable Loss (dB) + Antenna Factor (dB/m).

Site: AC2	Time: 2019/04/19 - 20:42
Limit: FCC_Part15_Band Edge(3m)	Engineer: Snake Ni
Probe: BBHA9120D_1-18GHz	Polarity: Horizontal
EUT: 2.4GHz HD Wireless Link	Power: DC 5V
Test Mode: Transmit by 10MHz Bandwidth at channel 2412MHz with Ant 2	

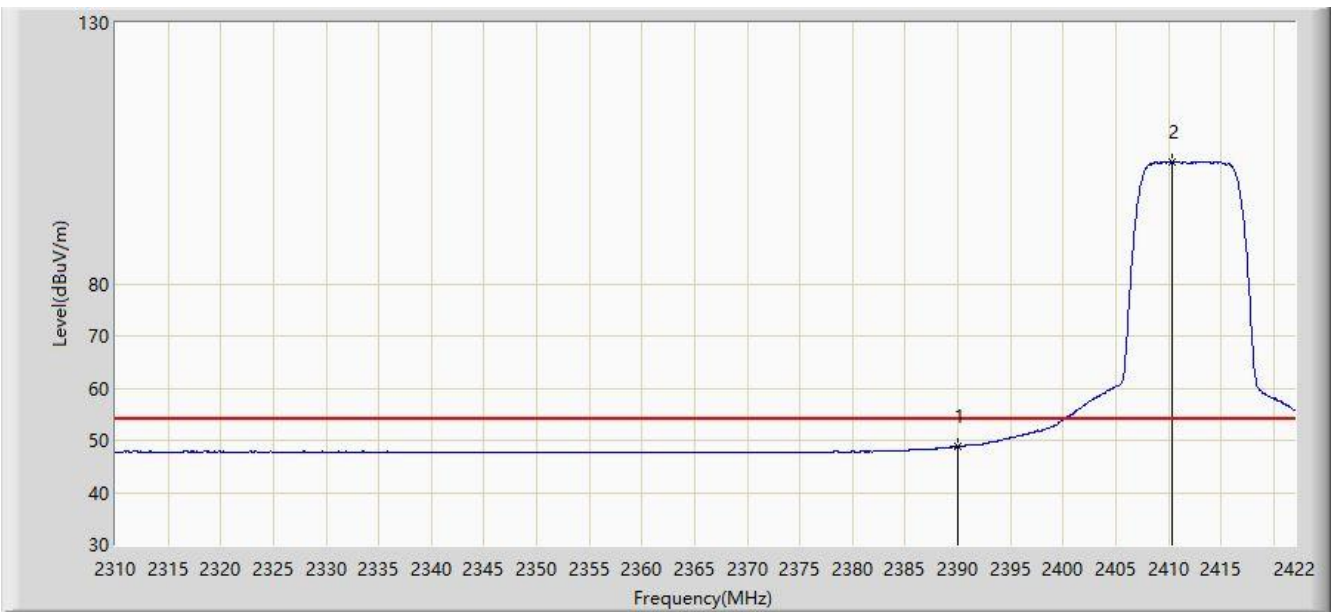

No	Flag	Mark	Frequency (MHz)	Measure Level (dBuV/m)	Reading Level (dBuV)	Over Limit (dB)	Limit (dBuV/m)	Factor (dB)	Type
1			2390.000	48.776	17.327	-5.224	54.000	31.449	AV
2		*	2410.296	103.449	72.056	N/A	N/A	31.393	AV

Note: Measure Level (dBuV/m) = Reading Level (dBuV) + Factor (dB)

Factor (dB) = Cable Loss (dB) + Antenna Factor (dB/m).

Site: AC2	Time: 2019/04/19 - 20:44
Limit: FCC_Part15_Band Edge(3m)	Engineer: Snake Ni
Probe: BBHA9120D_1-18GHz	Polarity: Vertical
EUT: 2.4GHz HD Wireless Link	Power: DC 5V
Test Mode: Transmit by 10MHz Bandwidth at channel 2412MHz with Ant 2	

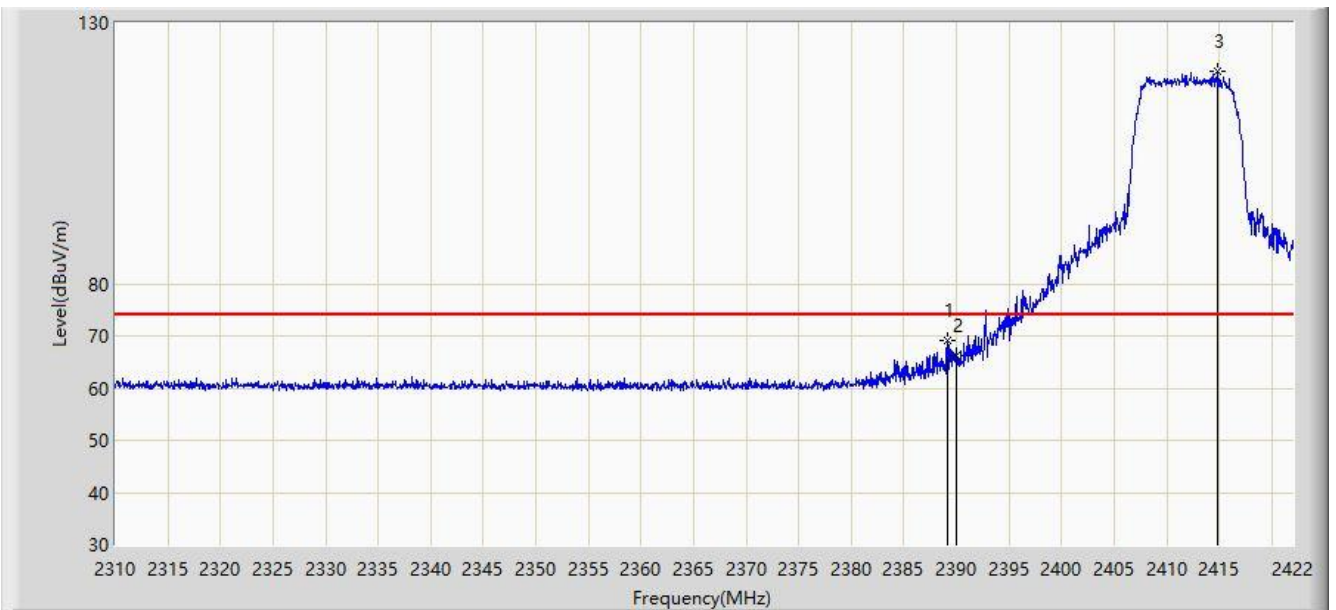

No	Flag	Mark	Frequency (MHz)	Measure Level (dBuV/m)	Reading Level (dBuV)	Over Limit (dB)	Limit (dBuV/m)	Factor (dB)	Type
1			2389.128	69.207	37.758	-4.793	74.000	31.449	PK
2			2390.000	66.314	34.865	-7.686	74.000	31.449	PK
3		*	2414.776	120.591	89.210	N/A	N/A	31.381	PK

Note: Measure Level (dB μ V/m) = Reading Level (dB μ V) + Factor (dB)

Factor (dB) = Cable Loss (dB) + Antenna Factor (dB/m).

Site: AC2	Time: 2019/04/19 - 20:45
Limit: FCC_Part15_Band Edge(3m)	Engineer: Snake Ni
Probe: BBHA9120D_1-18GHz	Polarity: Vertical
EUT: 2.4GHz HD Wireless Link	Power: DC 5V
Test Mode: Transmit by 10MHz Bandwidth at channel 2412MHz with Ant 2	

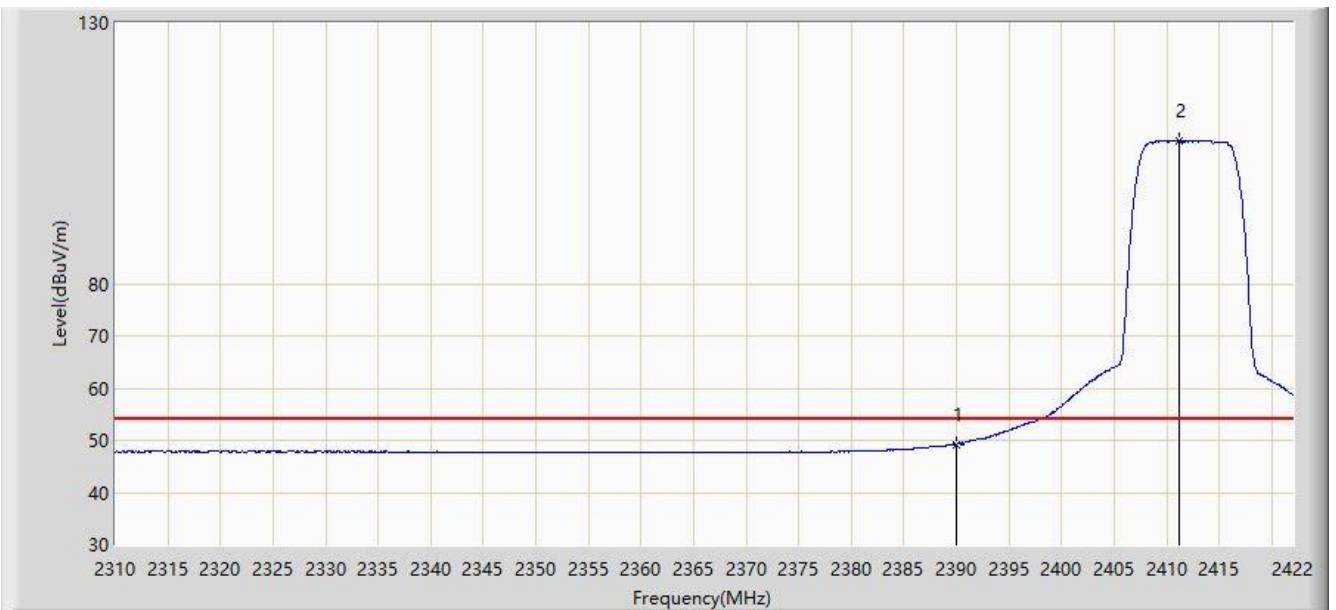

No	Flag	Mark	Frequency (MHz)	Measure Level (dBuV/m)	Reading Level (dBuV)	Over Limit (dB)	Limit (dBuV/m)	Factor (dB)	Type
1			2390.000	49.261	17.812	-4.739	54.000	31.449	AV
2		*	2411.192	107.486	76.096	N/A	N/A	31.390	AV

Note: Measure Level (dBuV/m) = Reading Level (dBuV) + Factor (dB)

Factor (dB) = Cable Loss (dB) + Antenna Factor (dB/m).

Site: AC2	Time: 2019/04/19 - 20:47
Limit: FCC_Part15_Band Edge(3m)	Engineer: Snake Ni
Probe: BBHA9120D_1-18GHz	Polarity: Horizontal
EUT: 2.4GHz HD Wireless Link	Power: DC 5V
Test Mode: Transmit by 10MHz Bandwidth at channel 2472MHz with Ant 2	

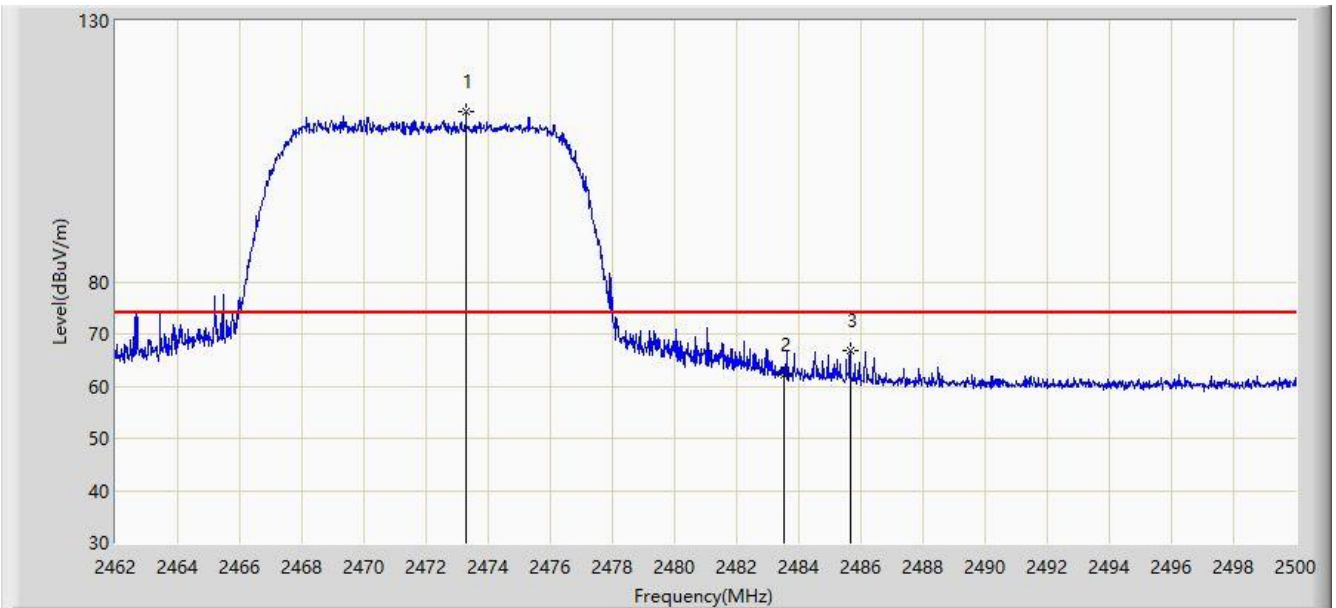

No	Flag	Mark	Frequency (MHz)	Measure Level (dBuV/m)	Reading Level (dBuV)	Over Limit (dB)	Limit (dBuV/m)	Factor (dB)	Type
1		*	2473.286	112.464	81.091	N/A	N/A	31.373	PK
2			2483.500	62.302	30.899	-11.698	74.000	31.403	PK
3			2485.655	66.763	35.353	-7.237	74.000	31.411	PK

Note: Measure Level (dBuV/m) = Reading Level (dBuV) + Factor (dB)

Factor (dB) = Cable Loss (dB) + Antenna Factor (dB/m).

Site: AC2	Time: 2019/04/19 - 20:49
Limit: FCC_Part15_Band Edge(3m)	Engineer: Snake Ni
Probe: BBHA9120D_1-18GHz	Polarity: Horizontal
EUT: 2.4GHz HD Wireless Link	Power: DC 5V
Test Mode: Transmit by 10MHz Bandwidth at channel 2472MHz with Ant 2	

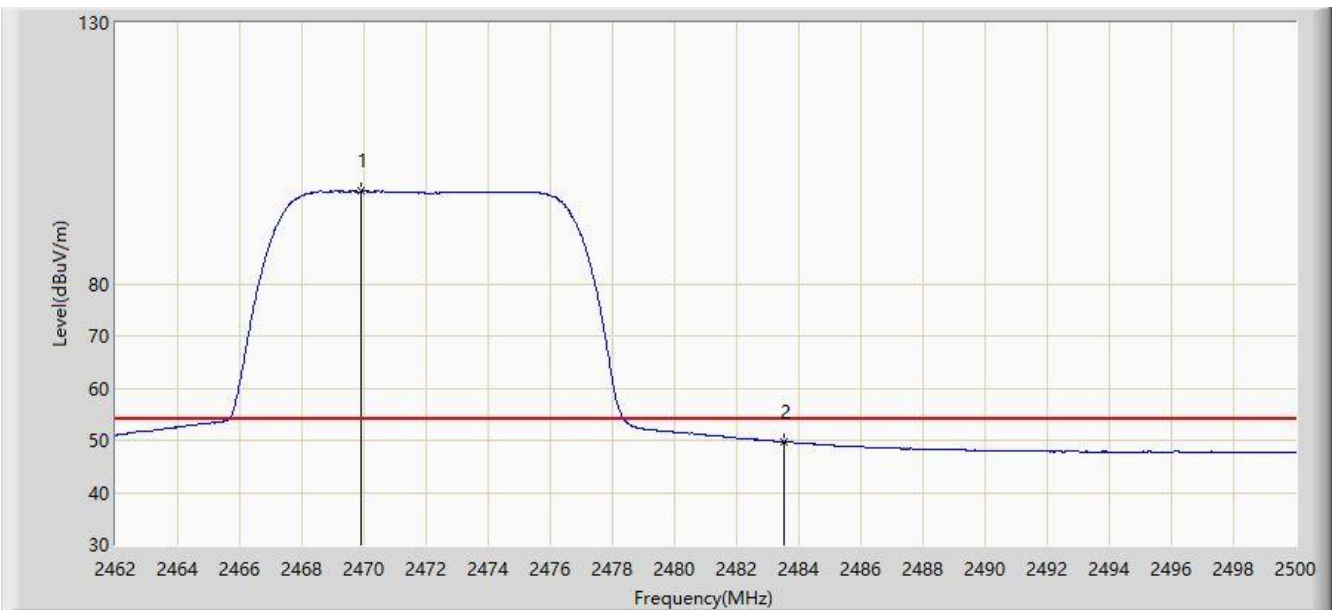

No	Flag	Mark	Frequency (MHz)	Measure Level (dBuV/m)	Reading Level (dBuV)	Over Limit (dB)	Limit (dBuV/m)	Factor (dB)	Type
1		*	2469.904	97.690	66.325	N/A	N/A	31.365	AV
2			2483.500	49.672	18.269	-4.328	54.000	31.403	AV

Note: Measure Level (dBuV/m) = Reading Level (dBuV) + Factor (dB)

Factor (dB) = Cable Loss (dB) + Antenna Factor (dB/m).

Site: AC2	Time: 2019/04/19 - 20:50
Limit: FCC_Part15_Band Edge(3m)	Engineer: Snake Ni
Probe: BBHA9120D_1-18GHz	Polarity: Vertical
EUT: 2.4GHz HD Wireless Link	Power: DC 5V
Test Mode: Transmit by 10MHz Bandwidth at channel 2472MHz with Ant 2	

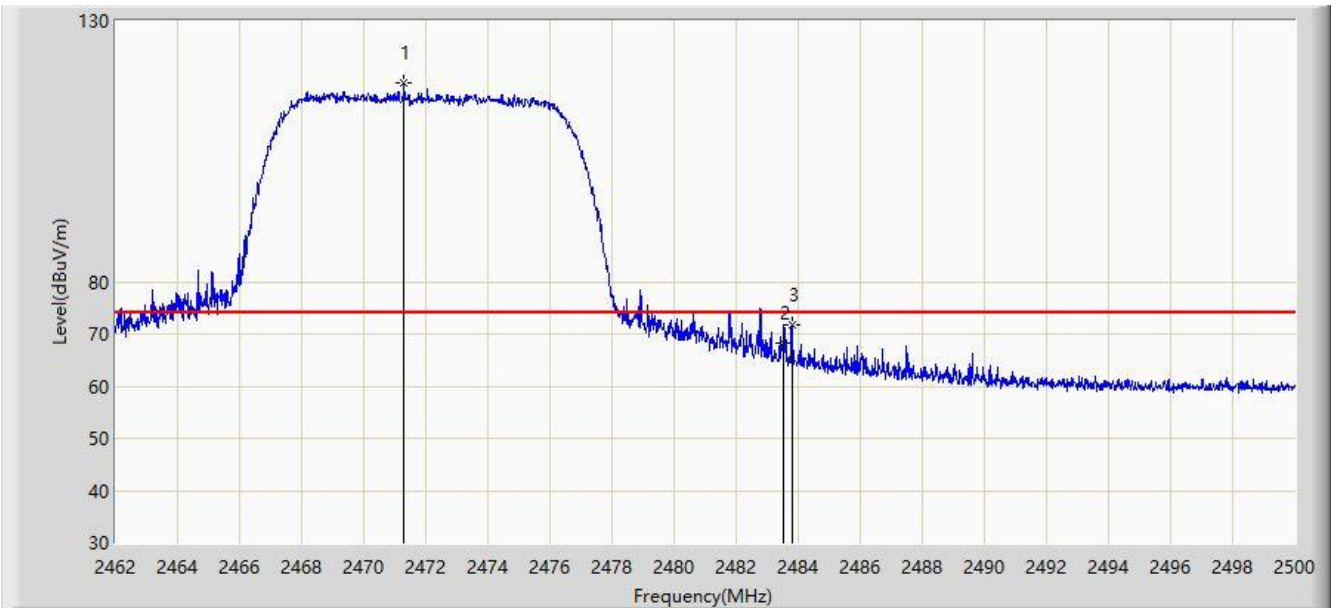

No	Flag	Mark	Frequency (MHz)	Measure Level (dBuV/m)	Reading Level (dBuV)	Over Limit (dB)	Limit (dBuV/m)	Factor (dB)	Type
1		*	2471.291	118.062	86.694	N/A	N/A	31.369	PK
2			2483.500	68.229	36.826	-5.771	74.000	31.403	PK
3			2483.812	71.688	40.284	-2.312	74.000	31.404	PK

Note: Measure Level (dB μ V/m) = Reading Level (dB μ V) + Factor (dB)

Factor (dB) = Cable Loss (dB) + Antenna Factor (dB/m).

Site: AC2	Time: 2019/04/19 - 20:52
Limit: FCC_Part15_Band Edge(3m)	Engineer: Snake Ni
Probe: BBHA9120D_1-18GHz	Polarity: Vertical
EUT: 2.4GHz HD Wireless Link	Power: DC 5V
Test Mode: Transmit by 10MHz Bandwidth at channel 2472MHz with Ant 2	

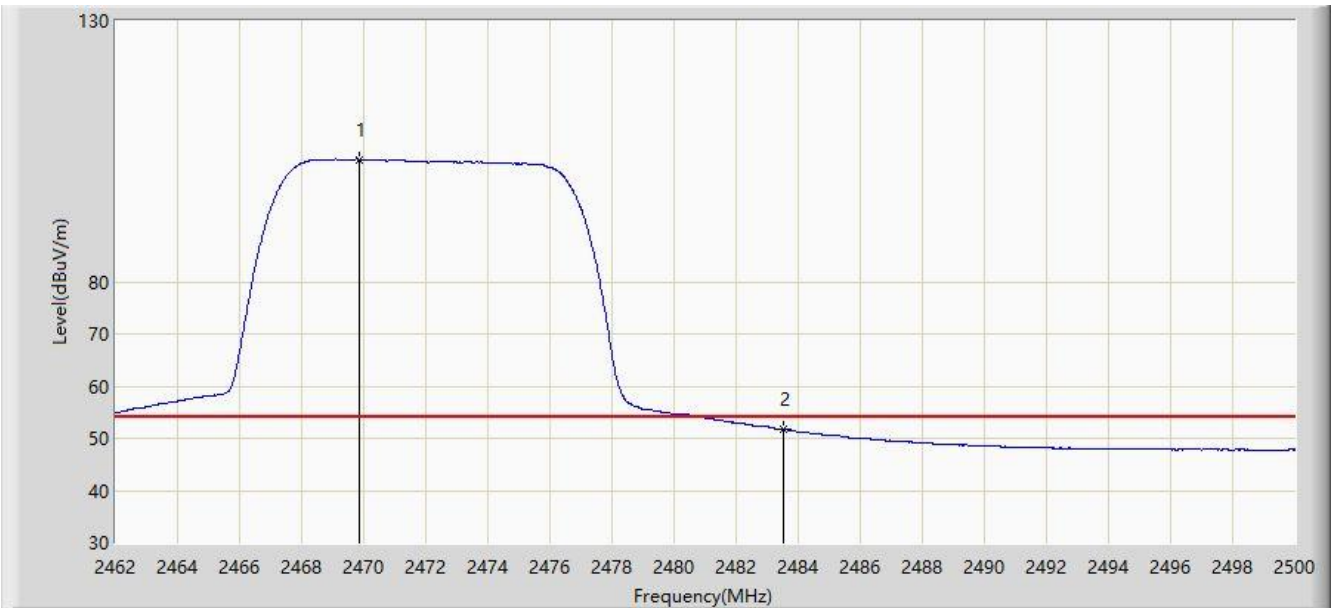

No	Flag	Mark	Frequency (MHz)	Measure Level (dBuV/m)	Reading Level (dBuV)	Over Limit (dB)	Limit (dBuV/m)	Factor (dB)	Type
1		*	2469.847	103.457	72.093	N/A	N/A	31.365	AV
2			2483.500	51.730	20.327	-2.270	54.000	31.403	AV

Note: Measure Level (dBuV/m) = Reading Level (dBuV) + Factor (dB)

Factor (dB) = Cable Loss (dB) + Antenna Factor (dB/m).

Site: AC2	Time: 2019/04/24 - 00:39
Limit: FCC_Part15_Band Edge(3m)	Engineer: Messiah Li
Probe: BBHA9120D_1-18GHz	Polarity: Horizontal
EUT: 2.4GHz HD Wireless Link	Power: DC 5V
Test Mode: Transmit by 10MHz Bandwidth at channel 2472MHz with Ant 1 (Model: IAUS11901c)	

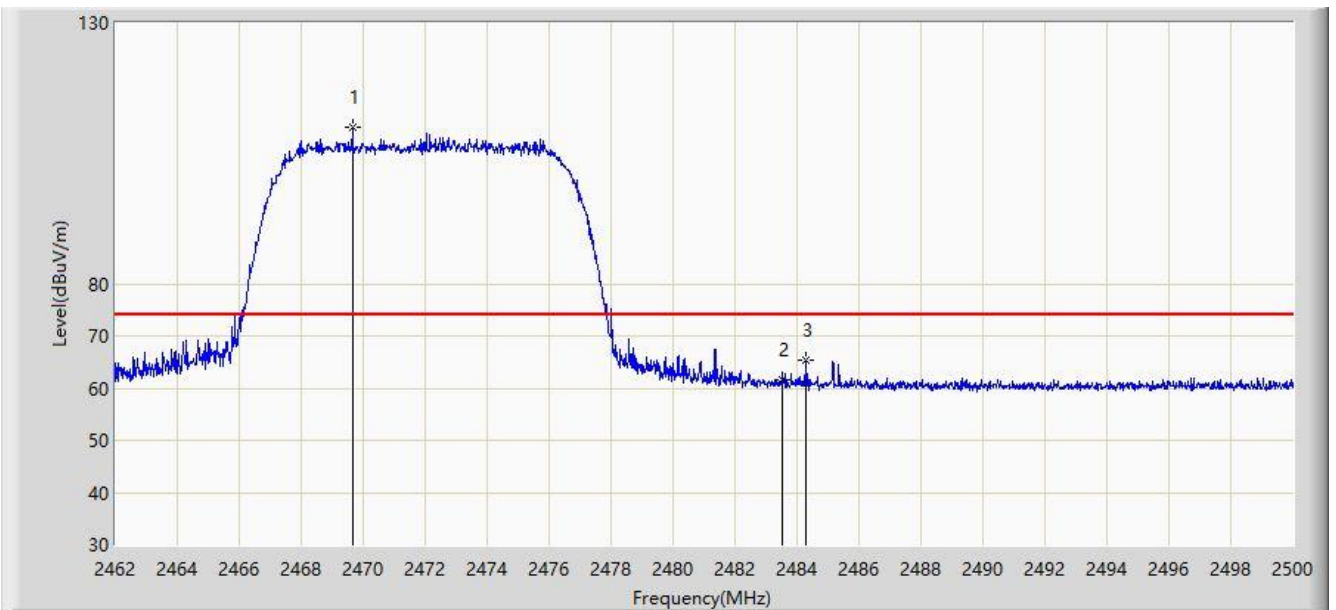

No	Flag	Mark	Frequency (MHz)	Measure Level (dBuV/m)	Reading Level (dBuV)	Over Limit (dB)	Limit (dBuV/m)	Factor (dB)	Type
1		*	2469.657	109.876	78.512	N/A	N/A	31.364	PK
2			2483.500	61.568	30.165	-12.432	74.000	31.403	PK
3			2484.306	65.451	34.045	-8.549	74.000	31.405	PK

Note: Measure Level (dBuV/m) = Reading Level (dBuV) + Factor (dB)

Factor (dB) = Cable Loss (dB) + Antenna Factor (dB/m).

Site: AC2	Time: 2019/04/24 - 00:41
Limit: FCC_Part15_Band Edge(3m)	Engineer: Messiah Li
Probe: BBHA9120D_1-18GHz	Polarity: Horizontal
EUT: 2.4GHz HD Wireless Link	Power: DC 5V
Test Mode: Transmit by 10MHz Bandwidth at channel 2472MHz with Ant 1 (Model: IAUS11901c)	

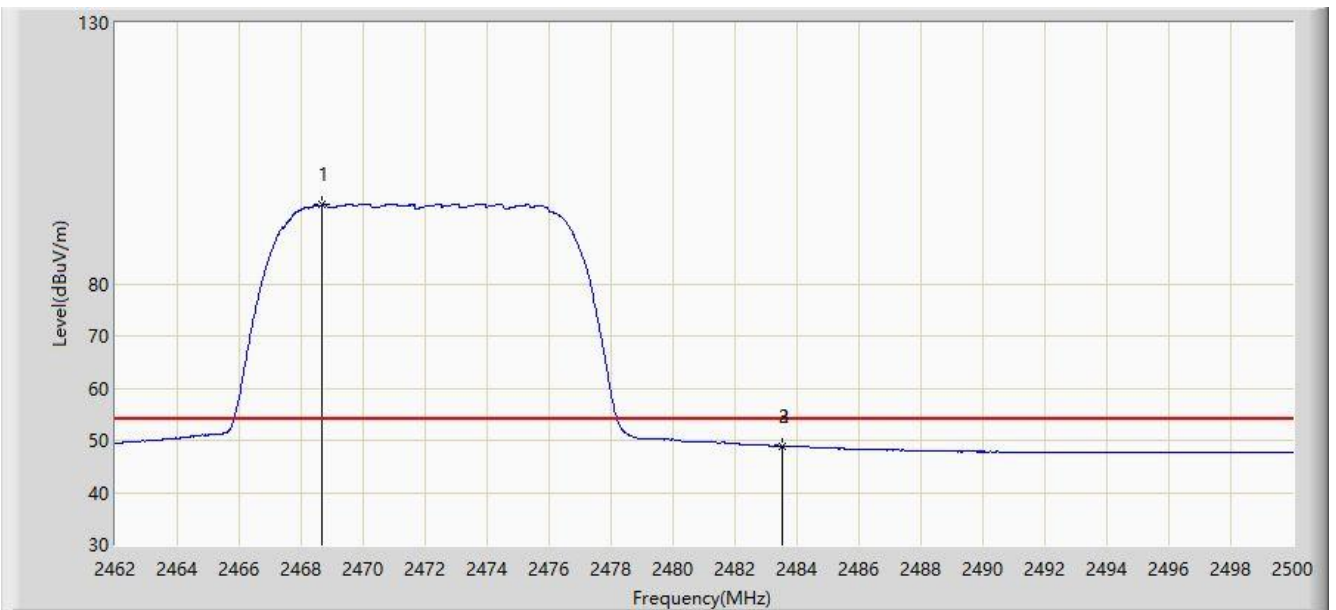

No	Flag	Mark	Frequency (MHz)	Measure Level (dBuV/m)	Reading Level (dBuV)	Over Limit (dB)	Limit (dBuV/m)	Factor (dB)	Type
1		*	2468.688	95.082	63.720	N/A	N/A	31.362	AV
2			2483.500	48.960	17.557	-5.040	54.000	31.403	AV
3			2483.527	48.961	17.558	-5.039	54.000	31.403	AV

Note: Measure Level (dB μ V/m) = Reading Level (dB μ V) + Factor (dB)

Factor (dB) = Cable Loss (dB) + Antenna Factor (dB/m).

Site: AC2	Time: 2019/04/24 - 11:14
Limit: FCC_Part15_Band Edge(3m)	Engineer: Messiah Li
Probe: BBHA9120D_1-18GHz	Polarity: Vertical
EUT: 2.4GHz HD Wireless Link	Power: DC 5V
Test Mode: Transmit by 10MHz Bandwidth at channel 2472MHz with Ant 1 (Model: IAUS11901c)	

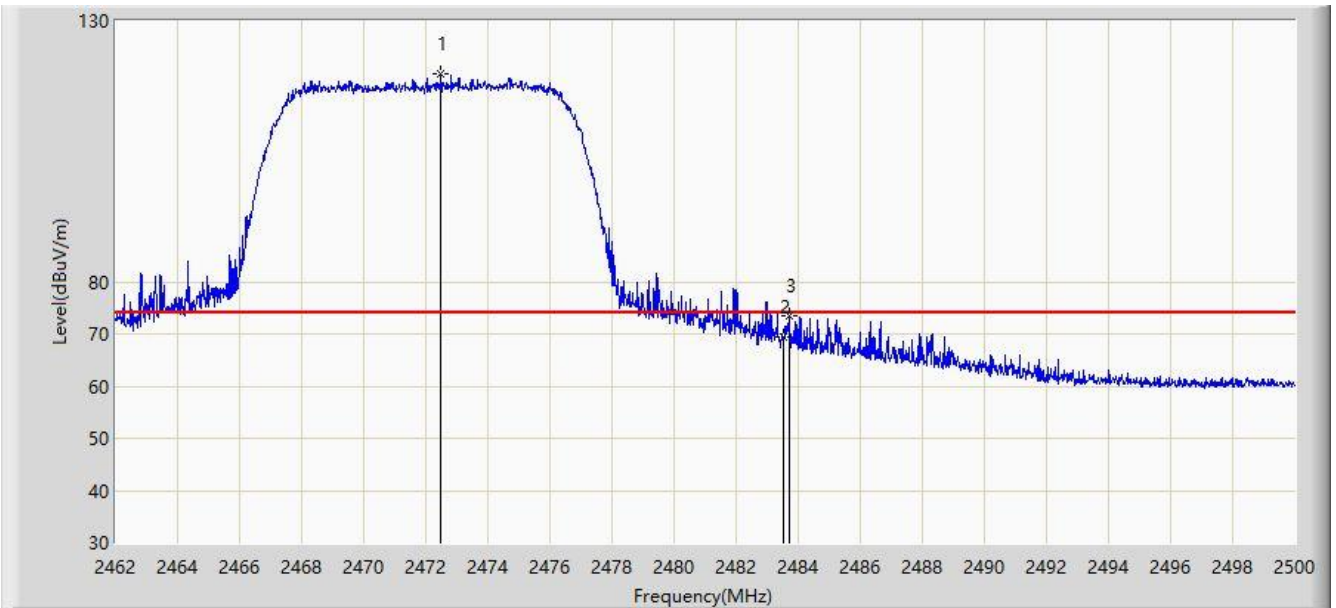

No	Flag	Mark	Frequency (MHz)	Measure Level (dBuV/m)	Reading Level (dBuV)	Over Limit (dB)	Limit (dBuV/m)	Factor (dB)	Type
1		*	2472.488	119.725	88.354	N/A	N/A	31.371	PK
2			2483.500	69.549	38.146	-4.451	74.000	31.403	PK
3			2483.698	73.464	42.061	-0.536	74.000	31.403	PK

Note: Measure Level (dBuV/m) = Reading Level (dBuV) + Factor (dB)

Factor (dB) = Cable Loss (dB) + Antenna Factor (dB/m).

Site: AC2	Time: 2019/04/24 - 11:15
Limit: FCC_Part15_Band Edge(3m)	Engineer: Messiah Li
Probe: BBHA9120D_1-18GHz	Polarity: Vertical
EUT: 2.4GHz HD Wireless Link	Power: DC 5V
Test Mode: Transmit by 10MHz Bandwidth at channel 2472MHz with Ant 1 (Model: IAUS11901c)	

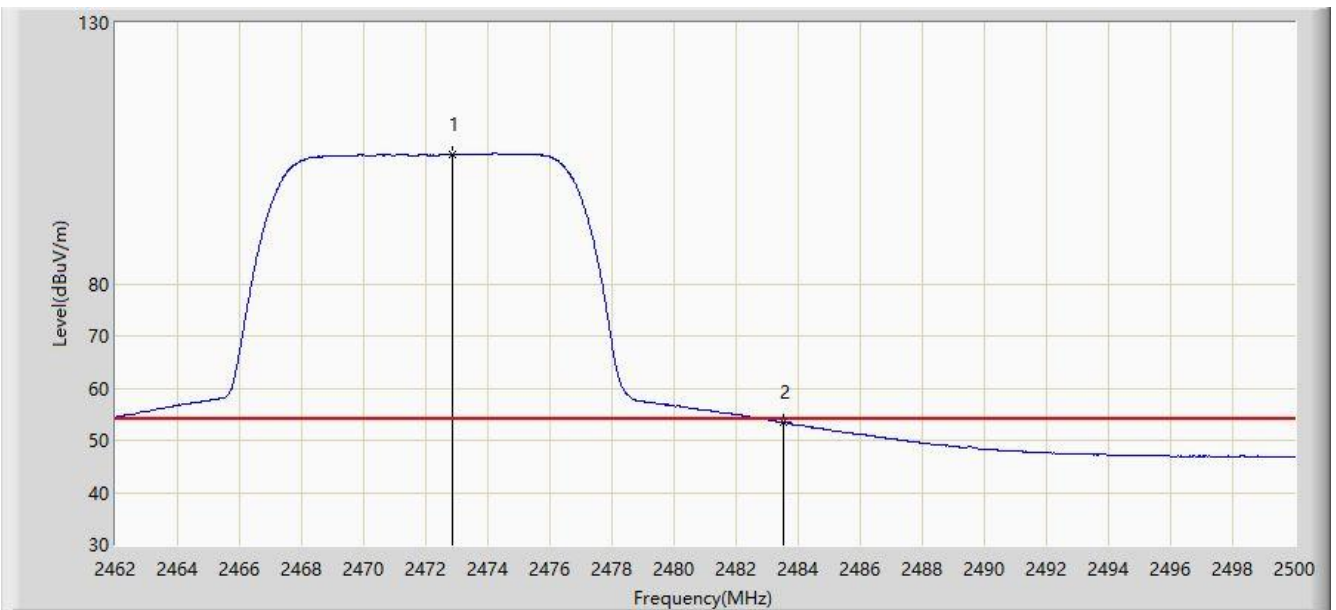

No	Flag	Mark	Frequency (MHz)	Measure Level (dBuV/m)	Reading Level (dBuV)	Over Limit (dB)	Limit (dBuV/m)	Factor (dB)	Type
1		*	2472.849	104.829	73.457	N/A	N/A	31.372	AV
2			2483.500	53.447	22.044	-0.553	54.000	31.403	AV

Note: Measure Level (dBuV/m) = Reading Level (dBuV) + Factor (dB)

Factor (dB) = Cable Loss (dB) + Antenna Factor (dB/m).

7.8. AC Conducted Emissions Measurement

7.8.1. Test Limit

FCC Part 15 Subpart C Paragraph 15.207 Limits		
Frequency (MHz)	QP (dBuV)	AV (dBuV)
0.15 - 0.50	66 - 56	56 - 46
0.50 - 5.0	56	46
5.0 - 30	60	50

Note 1: The lower limit shall apply at the transition frequencies.

Note 2: The limit decreases linearly with the logarithm of the frequency in the range 0.15MHz to 0.5MHz.

7.8.2. Test Setup

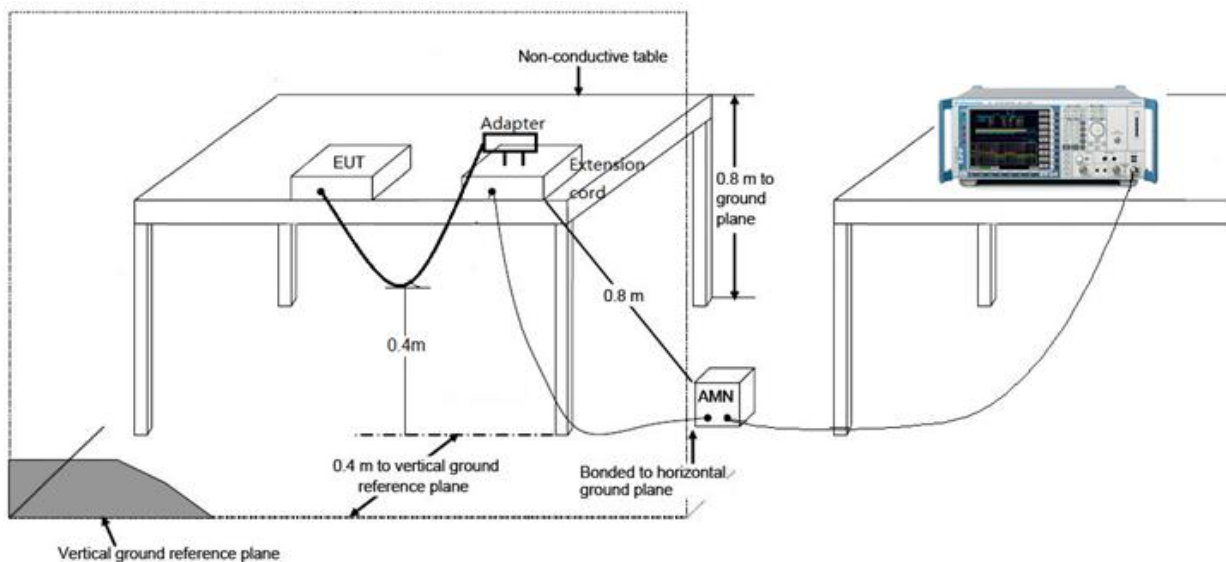

7.8.3. Test Result

Site: SR2	Time: 2019/04/23 - 18:52
Limit: FCC_Part15.207_CE_AC Power	Engineer: Messiah Li
Probe: ENV216_101683_Filter On	Polarity: Line
EUT: 2.4GHz HD Wireless Link	Power: DC 5V
Worst Case Mode: Transmit by 10MHz Bandwidth at channel 2442MHz with Ant 1	

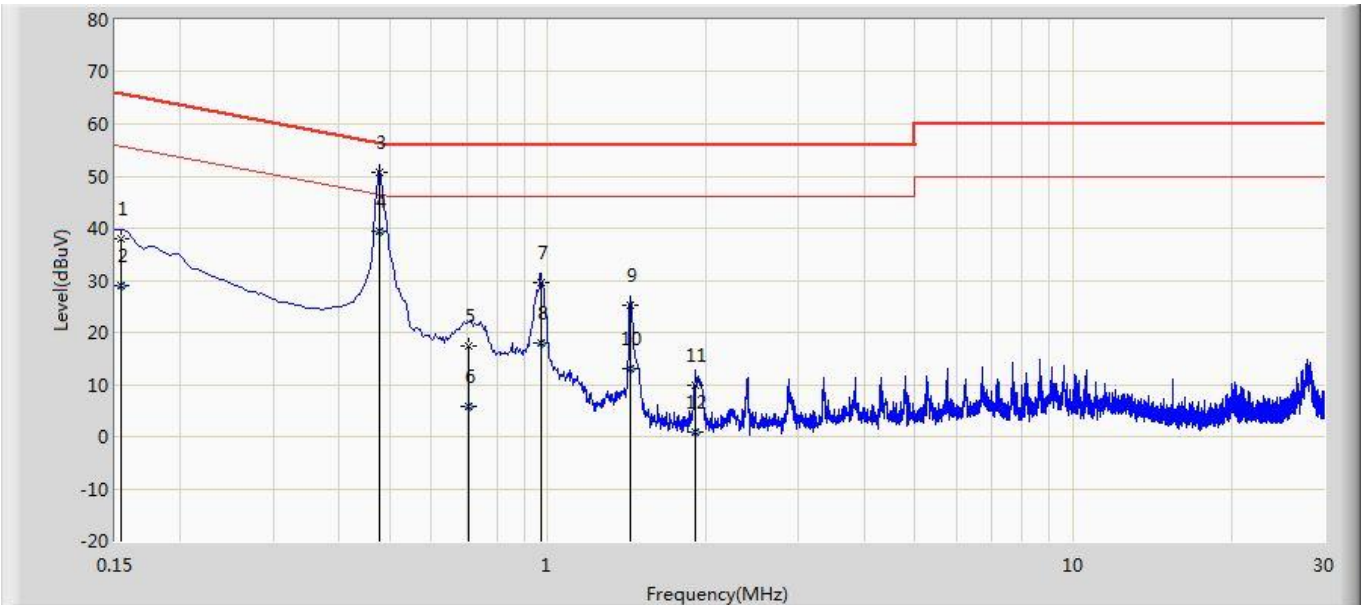

No	Flag	Mark	Frequency (MHz)	Measure Level (dBuV)	Reading Level (dBuV)	Margin (dB)	Limit (dBuV)	Factor (dB)	Type
1			0.154	37.857	27.118	-27.924	65.781	10.740	QP
2			0.154	28.854	18.115	-26.927	55.781	10.740	AV
3			0.478	50.668	40.519	-5.706	56.374	10.149	QP
4			0.478	39.416	29.268	-6.957	46.374	10.149	AV
5			0.706	17.402	7.342	-38.598	56.000	10.060	QP
6			0.706	5.858	-4.202	-40.142	46.000	10.060	AV
7			0.970	29.534	19.610	-26.466	56.000	9.924	QP
8			0.970	18.009	8.085	-27.991	46.000	9.924	AV
9			1.438	25.168	15.276	-30.832	56.000	9.891	QP
10			1.438	12.991	3.100	-33.009	46.000	9.891	AV
11			1.910	9.767	-0.108	-46.233	56.000	9.875	QP
12		*	1.910	0.831	-9.044	-45.169	46.000	9.875	AV

Note: Measure Level (dBμV) = Reading Level (dBμV) + Factor (dB)

Factor (dB) = Cable Loss (dB) + LISN Factor (dB).

Site: SR2	Time: 2019/04/23 - 18:58
Limit: FCC_Part15.207_CE_AC Power	Engineer: Messiah Li
Probe: ENV216_101683_Filter On	Polarity: Neutral
EUT: 2.4GHz HD Wireless Link	Power: DC 5V
Worst Case Mode: Transmit by 10MHz Bandwidth at channel 2442MHz with Ant 1	

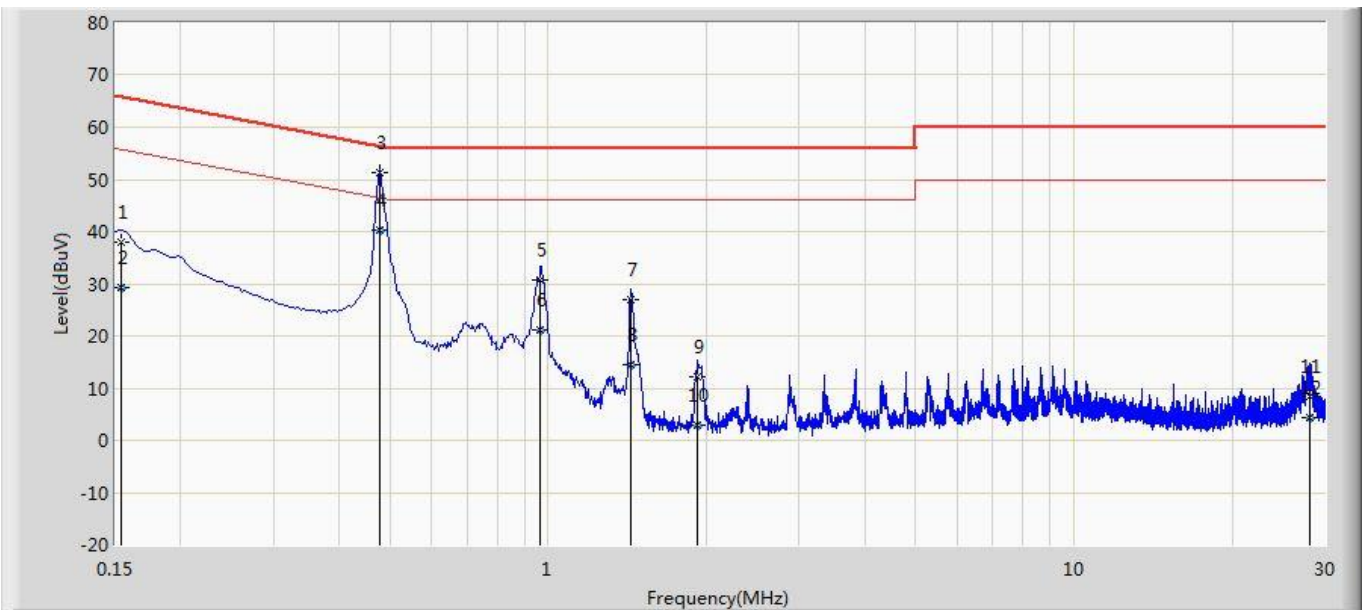

No	Flag	Mark	Frequency (MHz)	Measure Level (dBuV)	Reading Level (dBuV)	Margin (dB)	Limit (dBuV)	Factor (dB)	Type
1			0.154	37.954	27.238	-27.828	65.781	10.716	QP
2			0.154	29.146	18.430	-26.635	55.781	10.716	AV
3			0.478	51.170	41.000	-5.203	56.374	10.170	QP
4			0.478	40.170	30.000	-6.203	46.374	10.170	AV
5			0.966	30.789	20.862	-25.211	56.000	9.927	QP
6			0.966	21.134	11.207	-24.866	46.000	9.927	AV
7			1.438	26.879	16.986	-29.121	56.000	9.892	QP
8			1.438	14.580	4.688	-31.420	46.000	9.892	AV
9			1.922	12.029	2.153	-43.971	56.000	9.876	QP
10		*	1.922	2.801	-7.076	-43.199	46.000	9.876	AV
11			28.154	8.325	-2.073	-51.675	60.000	10.398	QP
12			28.154	4.291	-6.107	-45.709	50.000	10.398	AV

Note: Measure Level (dBμV) = Reading Level (dBμV) + Factor (dB)

Factor (dB) = Cable Loss (dB) + LISN Factor (dB).

8. CONCLUSION

The data collected relate only the item(s) tested and show that the device is in compliance with Part 15C of the FCC Rules.

_____ The End _____

Appendix A – Test Setup Photograph

Refer to “ 1904RSU030-UT” file.

Appendix B – EUT Photograph

Refer to “ 1904RSU030-UE” file.