

CS 7600

User Guide

Notice

CARESTREAM Dental Systems are designed to meet international safety and performance standards. Personnel operating the unit must have a thorough understanding of the proper operation of the system. This guide has been prepared to aid dental professionals to understand and operate the system. Do not operate the system before reading this guide and gaining a clear understanding of the operation of the system. If any part of this guide is not clear, please contact your Carestream Dental LLC representative for clarification.



WARNING: Read the “Safety, Regulatory and the Technical Specifications User Guide” and make sure you observe all the Warnings and Cautions before using the CS 7600.

The CS 7600 is intended for digital dental radiography using an imaging plate (storage phosphor screen) for radiographic diagnostic intraoral images.

The CS 7600 in addition, optionally provides the Scan & Go technology to enable dental practitioners prior to acquisition to record the dental imaging plates with exam acquisition data.

No part of this guide may be reproduced without the express permission of Carestream Dental LLC.

U.S. Federal law restricts this device to sale by or on the order of a dentist or physician.

This document is originally written in English.

Guide Name: CS 7600 User Guide

Part Number: 8J4071

Revision Number: 07

Print Date: 2019-03

In this guide, all trademarks and registered trademarks are the property of their respective holders.

The brand names and logos reproduced in this guide are copyright.

CS 7600 complies with Directive 93/42/CEE relating to medical equipment.



Manufacturer



Carestream Dental LLC

3625 Cumberland Boulevard, Suite 700,
Atlanta, GA USA 30339

Authorized Representative in the European Community



Trophy

4, Rue F. Pelloutier

Croissy-Beaubourg

77435 Marne-la-Vallée, Cedex 2

France

Contents

Chapter 1	Conventions in this Guide	1
Conventions in this Guide		
Chapter 2	Introduction	3
CS 7600 System Overview	CS 7600 Components Overview	4
	Scanner Overview	4
	Smart Imaging Plates Overview	6
	Hygienic Sheaths	7
	Scan & Go Overview	9
	Scan & Go Generation 1 (Models Released before June 2012)	9
	Scan & Go Generation 2 (Models Released from June 2012)	10
	Connecting the Scan & Go Device	11
	Scanner Shelf	11
Chapter 3	Computer System Requirements	13
Software Overview	General Software Overview	13
	Single Image Acquisition Interface Overview	13
	Full Mouth Series (FMS) Acquisition Interface Overview	14
	Dental Imaging Software Main Toolbar	17
	CS 7600 Configuration Window	18
Chapter 4	Computer System Requirements	19
Scanner Interface Overview	CS 7600 Scanner Interface Overview	19
	Scanner Interface Icons	20
	Working with the Scanner	22
	Turning on the Scanner	22
	Image Acquisition	22
	Scanner Info	23
	Erasing the Imaging Plates	24
Chapter 5	CS 7600 Imaging Software Overview	25
CS 7600 Image Acquisition Interface	CS 7600 Image Acquisition Interface Overview	25
	Full Mouth Series Image Acquisition Interface	26
Chapter 6	Introduction	33
Acquiring Images without Scan & Go	Acquiring Single Image	34
	Starting the Imaging Software	34

	Preparing the Imaging Plates	35
	Inserting the Imaging Plate.	35
	Performing the X-rays.	36
	Scanning the Imaging Plates	37
	Acquiring Multiple Images.	40
	Preparing Acquisition of FMS Images	40
Chapter 7	Introduction.	43
Acquiring Images	Acquiring Single Image Using Scan & Go.	44
Using Scan & Go	Starting the Imaging Software	44
	Preparing the Imaging Plates	44
	Tagging the Imaging Plate with the Scan & Go	44
	Performing the X-rays.	45
	Scanning the Imaging Plates	45
	Retrieving a Fallen Imaging Plate.	45
	Acquisition Related Procedures	45
	Acquiring Multiple Images (FMS) Using Scan & Go.	46
	Acquiring Images.	46
	Starting the Imaging Software	46
	Opening the Image Acquisition Interface.	46
	Preparing the Imaging Plates	46
	Tagging the Imaging Plate with the Scan & Go	46
	Performing the X-rays.	46
	Scanning the Imaging Plates	46
	Acquisition Related Procedures	46
Chapter 8	Processing the Images.	47
Acquisition Related	Re-tagging Imaging Plates	48
Procedures	Storing the Images	48
	Clearing Scanner Memory	48
	Erasing the Imaging Plates	49
Chapter 9	General	51
Scanner Settings	Scanner Settings	51
	Brightness Control	52
	IP Setup	52
	Viewer	54
	Working with Settings.	55
	General Settings Tab	55
	Working with the General Settings Tab	57
	Scan & Go Tab	61
	Scanners Connections Tab.	62
	Working with the Scanners Connections Tab.	63
	About Peer to Peer Connection.	63
	Creating a Peer to Peer Connection.	64

	Disconnecting a Peer to Peer Connection	65
	Clearing Scanner Memory	66
Chapter 10	Imaging Plate Care	69
Maintenance	Handling and Storage of Imaging Plates	69
	Cleaning the Imaging Plate	70
	Cleaning Materials	70
	Cleaning Method	70
	Disinfecting the Hygienic Sheath and the Imaging Plates .71	
	Frequency of Disinfection	71
	Disinfection Solutions	71
	Disinfection Method	71
	Disposing of the Imaging Plate	71
	Scanner Care	72
	Cleaning the Scanner Body	72
	Cleaning the Detachable Insertion Panels	72
	Cleaning the Scanner Rollers	75
	Scan & Go Device Care	78
	Cleaning the Scan & Go	78
	Replacing the Battery (Scan & Go Generation 1)	78
Chapter 11	Quick Troubleshooting	81
Troubleshooting	Retrieving a Fallen Imaging Plate	84
Appendix:	CS 7600 Consumables & Accessories	89
	Scanner Manager	90
	Accessing the Scanner Manager	90
	Scanner Info	91
	Scanner Setup	92
	Update Scanner	93
	Updating the Scanner using the USB Storage Device	93
	Updating the Scanner using the Scanner Manager Tool	94
	Collect Info	95
	Diagnose Connection	96

1 Conventions in this Guide

Conventions in this Guide

The following special messages emphasize information or indicate potential risk to personnel or equipment:



WARNING: Warns you to avoid injury to yourself or others by following the safety instructions precisely.



CAUTION: Alerts you to a condition that might cause serious damage.



Important: Alerts you to a condition that might cause problems.



Note: Emphasizes important information.



Tip: Provides extra information and hints.

2 CS 7600 System Overview

Introduction



Note: The CS 7600 is intended for dental professionals. You are required to have training to use the CS 7600.

CS 7600 is a scanner system for intraoral X-ray exposed imaging plates.

The CS 7600 is intended for digital dental radiography using an imaging plate (storage phosphor plate) for radiographic diagnostic intraoral images. The CS 7600 system is used to scan and review intraoral dental X-ray images. When scanning the X-ray exposed imaging plate a digital image is previewed on the scanner's LCD and saved to the scanner's internal memory. After scanning, the scanner erases the imaging plate and ejects it. The imaging plate is ready for re-use.

The exam acquisition's scanned image is sent over the network to the workstation's image Acquisition interface. Using the image Acquisition interface the image is processed and reviewed.

The image Acquisition interface sends the images to the CS Imaging Software, which archives the acquired images.

The scanner connects directly to the network, or is connected peer-to-peer to the workstation.

The scanner can be optionally placed on a desk/counter top or mounted on a wall, using a special shelf (adapter).

The system is composed of the following elements:

- CS 7600 scanning device (page 4)
- Smart imaging plates (page 6)
- Scan & Go device (optional, page 9)



Note: The scanner is supplied with a separate viewing and archiving software package: *CS Imaging Software*, approved by Carestream Dental.



Note: The CS 7600 User Guide is also provided as a PDF file on the supplied CD-ROM.

This device complies with part 15 of the FCC Rules and contains licence-exempt transmitter(s)/ receiver(s) that comply with Innovation, Science and Economic Development Canada's licence-exempt RSS(s). Operation is subject to the following two conditions: (1) This device may not cause interference. (2) This device must accept any interference, including interference that may cause undesired operation of the device.

L'émetteur/récepteur exempt de licence contenu dans le présent appareil est conforme aux CNR d'Innovation, Sciences et Développement économique Canada applicables aux appareils radio exempts de licence. L'exploitation est autorisée aux deux conditions suivantes:

- 1) L'appareil ne doit pas produire de brouillage;
- 2) L'appareil doit accepter tout brouillage radioélectrique subi, même si le brouillage est susceptible d'en compromettre le fonctionnement.

Caution: Changes or modifications to this unit not expressly approved by the party responsible for compliance could void the user's authority to operate the equipment.

CS 7600 Components Overview

Scanner Overview

The CS 7600 scanner performs the functions necessary for scanning and acquiring images from the imaging plates.

Figure 1 CS 7600 Front View

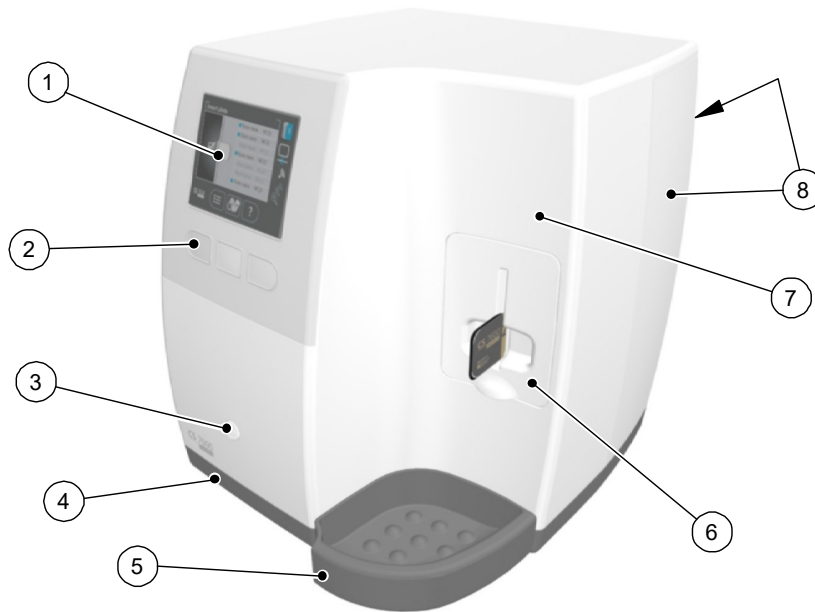

- 1 3.5" QVGA color LCD (320 X 240 pixels, landscape matrix)
- 2 Function buttons for scanner use and menu navigation
- 3 On/Off button + LED power indicator
On/Off button functions:
 - Turn scanner On: press for 1 second
 - Turn scanner Off (close application and files and then turn off): press for 2 seconds
- 4 Base
- 5 Intraoral imaging plates tray
- 6 Detachable insertion panel. The CS 7600 makes use of three insertion panel sizes according to the inserted imaging plates size (0, 0-3, or 4).
- 7 Front cover
- 8 Back covers

Figure 2 CS 7600 Rear View

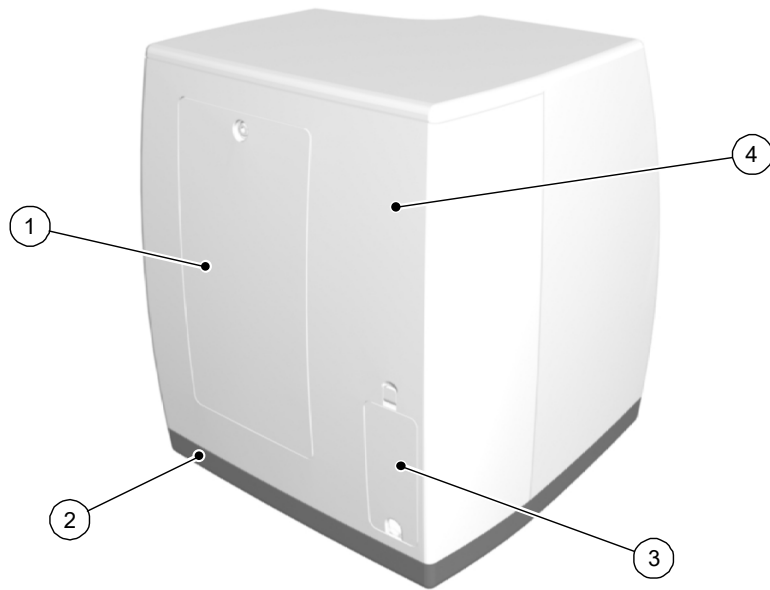

- 1 Service door
- 2 Base
- 3 Cables compartment for power supply connection and interface ports (RJ-45 Ethernet port)
- 4 Back cover

Figure 3 Cables Compartment in Detail

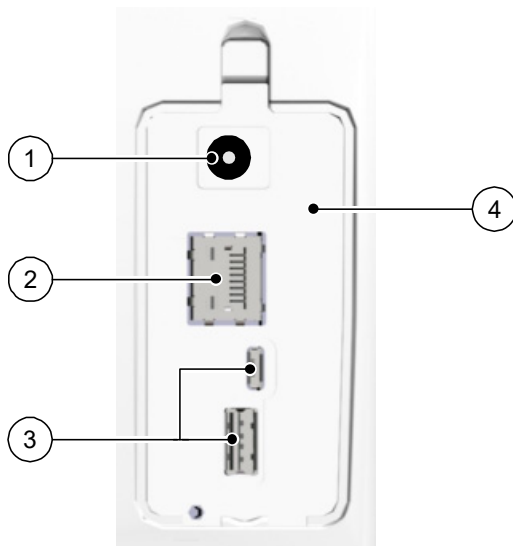





- 1 Power supply inlet
- 2 RJ-45 Ethernet port (Ethernet activity LEDs: yellow indicates speed, green indicates that the ethernet is connected)
- 3 Service ONLY ports
- 4 Compartment cover

Smart Imaging Plates Overview

The CS 7600 works with five imaging plate sizes: 0 to 4. The scanned image file size depends on the imaging plate size and the scanning resolution set by the user.

The smart function of the imaging plates is utilized when using the Scan & Go device.

Table 1 Intraoral Imaging Plate Sizes

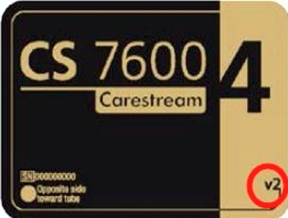
Size	Illustration	Application
0	 The illustration shows a small, rectangular imaging plate. It is black with a yellow top edge and a yellow right edge. The text 'CS 7600' is at the top left, 'Carestream' is below it, and a large '0' is on the right. At the bottom right, there is a 'v2' logo. At the bottom left, there is a barcode and the text 'Cyanide side toward tube'.	Periapical exam (Pediatric dentistry)
1	 The illustration shows a rectangular imaging plate, larger than size 0. It is black with a yellow top edge and a yellow right edge. The text 'CS 7600' is at the top left, 'Carestream' is below it, and a large '1' is on the right. At the bottom right, there is a 'v2' logo. At the bottom left, there is a barcode and the text 'Cyanide side toward tube'.	Bitewing exam (Pediatric dentistry)
2	 The illustration shows a rectangular imaging plate, larger than size 1. It is black with a yellow top edge and a yellow right edge. The text 'CS 7600' is at the top left, 'Carestream' is below it, and a large '2' is on the right. At the bottom right, there is a 'v2' logo. At the bottom left, there is a barcode and the text 'Cyanide side toward tube'.	Periapical exam (Adult)
3	 The illustration shows a rectangular imaging plate, larger than size 2. It is black with a yellow top edge and a yellow right edge. The text 'CS 7600' is at the top left, 'Carestream' is below it, and a large '3' is on the right. At the bottom right, there is a 'v2' logo. At the bottom left, there is a barcode and the text 'Cyanide side toward tube'.	Bitewing exam (Adult)
4	 The illustration shows a large rectangular imaging plate. It is black with a yellow top edge and a yellow right edge. The text 'CS 7600' is at the top left, 'Carestream' is below it, and a large '4' is on the right. At the bottom right, there is a 'v2' logo inside a red circle. At the bottom left, there is a barcode and the text 'Cyanide side toward tube'.	Occlusal exam

The imaging plate has two sides: the active side for capturing the X-ray image and the inactive side. The active side of the imaging plate includes an orientation mark 'c' to facilitate accurate positioning within the patient's mouth. The inactive side has a printed dot that corresponds to the location of the orientation mark on the active side. This dot is visible through the transparent hygienic sheath and is also helpful for positioning the imaging plate correctly in the patient's mouth.

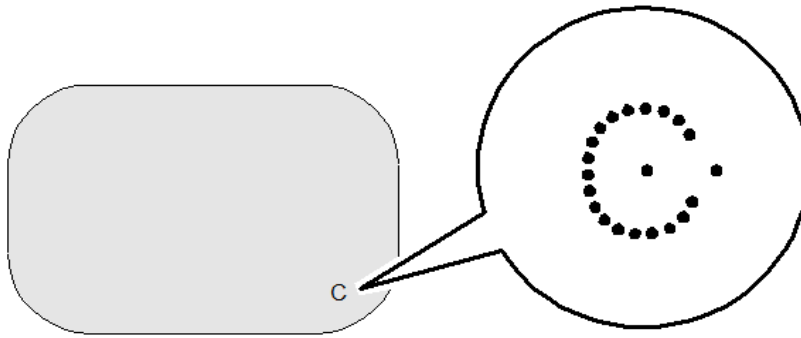

Active side

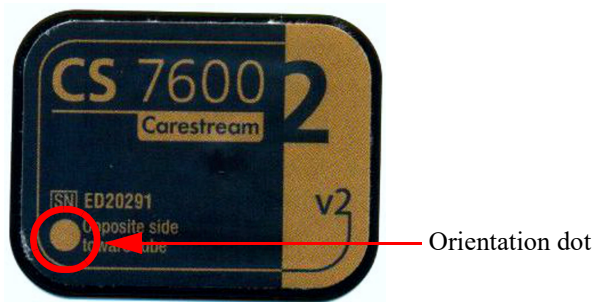

Inactive side



Important: Use only Carestream Dental imaging plates and hygienic sheaths!

Hygienic Sheaths

For each imaging plate size there is a corresponding one-time use, disposable, hygienic sheath for preventing cross contamination. The transparent side allows you to see the orientation mark for positioning the imaging plate correctly in the patient's mouth while the opaque side protects the active side of the inserted imaging plate from light damaging effects. The foam strip is a stopper which prevents inserting the hygienic sheath by mistake into the scanner (as long as the insertion direction is correct).

Figure 4 Hygienic Sheath (front view)

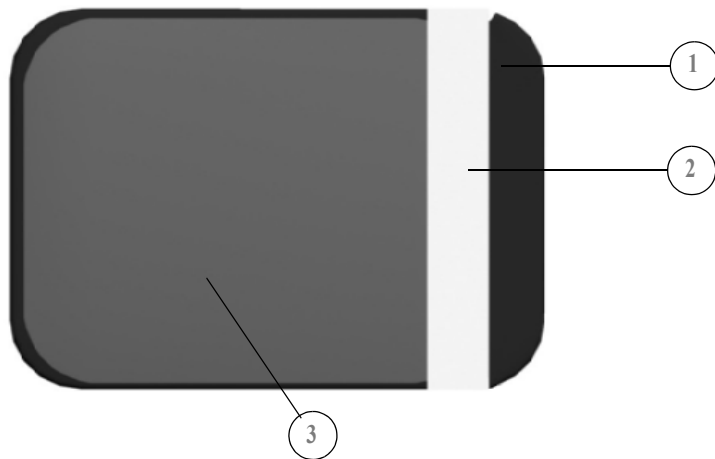

- 1 Adhesive strip (for sealing the hygienic sheath)
- 2 Foam stopper
- 3 Sheath, transparent on one side and with a light protection barrier on the other side

Scan & Go Overview





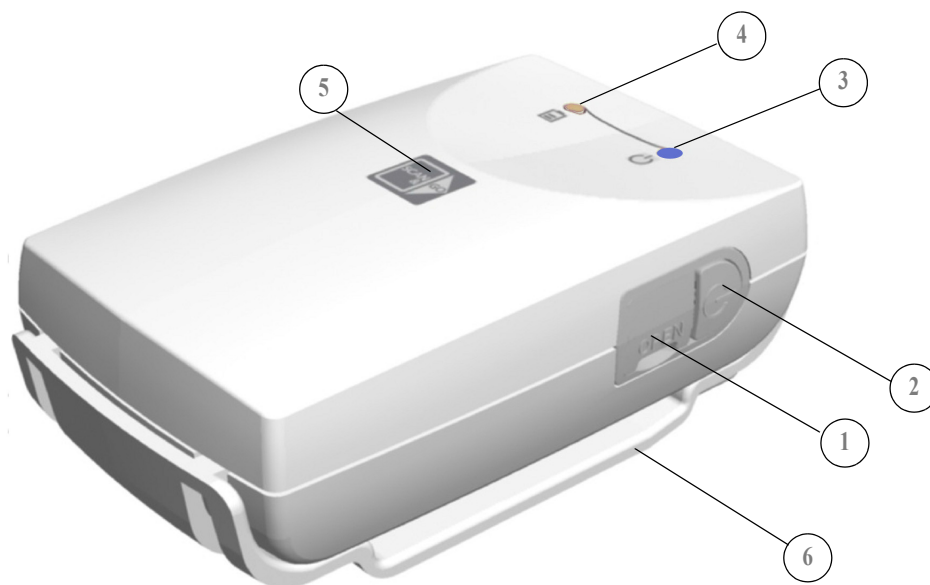

Scan & Go is an optional device that enables you to link the imaging plate to a specific exam acquisition (for example, patient) prior to acquisition. When the plate is inserted into the scanner, the information which was tagged onto the plate is retrieved by the scanner and the imaging plate is scanned automatically according to this information (resolution, target workstation, etc). Scanned images are then routed automatically to the correct workstation, associated to the correct exam acquisition and placed in the correct frame in the CS 7600 image Acquisition interface.

Scan & Go Generation 1 (Models Released before June 2012)

Scan & Go Generation 1 (models released before June 2012) have a rechargeable battery, accessible from the panel at the back of the device.

Figure 5 Scan & Go device, Generation 1 (before June 2012)



- 1 USB 2.0 port
- 2 On/Off button
- 3 On/Off/Recording LED status indicator (blue)
 -  Turning On/Off, 3 short flashes
 -  Standby (intermittent flashing)
 -  Recording data to the imaging plate (successive short flashes)
- 4 Battery LED status indicator (amber):
 -  Charging (static light)
 -  Low battery (successive short flashes)
 -  (light Off) battery charged
- 5 Recording surface for imaging plate
- 6 Mounting adapter

Scan & Go Generation 2 (Models Released from June 2012)

A second generation of Scan & Go device is available from June 2012. The following improvements have been made to the second generation Scan & Go device:

- Faster scanning - Approximately 1/4 sec instead of 1 sec
- No battery - Therefore no need for charging
- No on off switch - Turns on automatically when the USB is connected

Figure 6 Scan & Go device, Generation 2 (after June 2012)

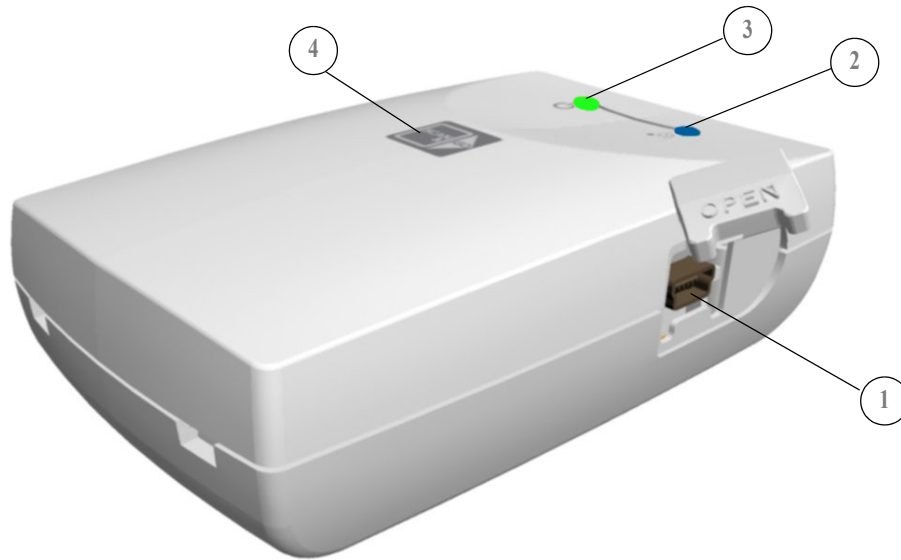

1 USB 2.0 port

2 On/Off/Recording LED status indicator (blue)



Power Up: One Flash & Beep (Internal FW)



Beacon: Flashes blue every few seconds when the image Acquisition interface is open (Not during Tagging)



Tagging OK: One flash (long) & 1 beep (long)



Tagging Fail: One Red flash (long) & 1 beep (long)

3



Connected to USB: LED status indicator (green)

4 Recording surface for imaging plate

Connecting the Scan & Go Device

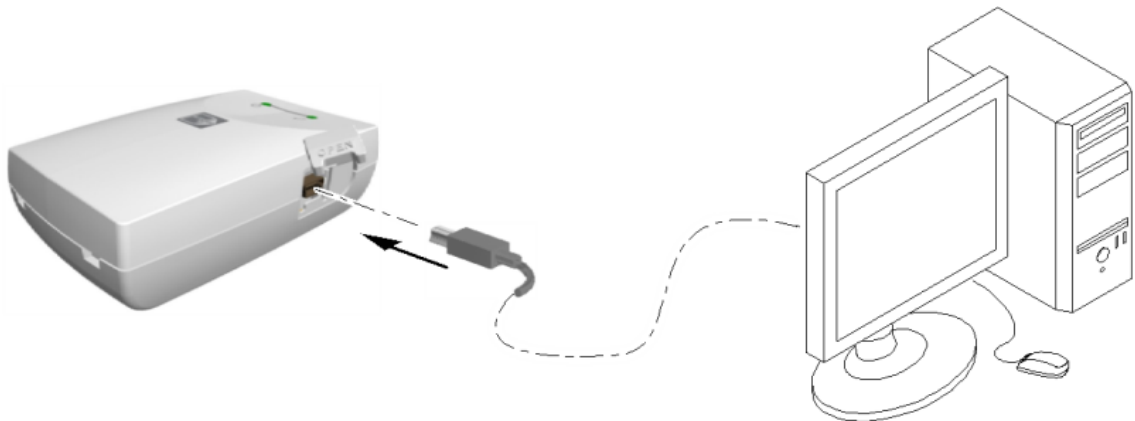

To connect the Scan & Go:

Connect the USB cable to the computer and to the USB port on the Scan & Go device.

- Scan and Go Generation 1, the right LED illuminates amber, the left LED flashes blue to indicate that it is ready for use.
- Scan and Go Generation 2, the right LED flashes green three times, the left LED illuminates green continuously and the device beeps three times to indicate that it is ready for use.

Scanner Shelf

The CS 7600 can be optionally mounted on the wall using a shelf bracket.

The CS 7600 is attached to the shelf by a single central tightening nut.

For more information on Scanner Shelf Installation, see document [HT014_20111006_EN](#)

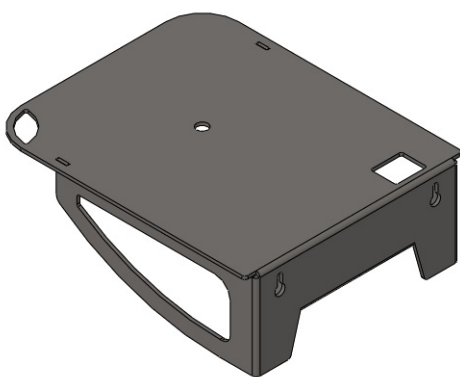

Scanner Shelf

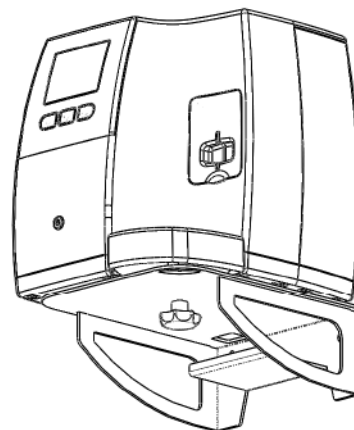

Scanner on Shelf

3 Software Overview

Computer System Requirements



Important: It is **MANDATORY** to check that the computer system configuration is compatible with the computer minimum system requirements specified in the Safety, Regulatory & Technical Specifications User Guide. If necessary, update your computer system configuration.

General Software Overview

The CS 7600 intraoral imaging system operates with the following software:

- CS Imaging Software
 - Single Image Acquisition Interface. See “Single Image Acquisition Interface Overview” on page 13.
 - Full Mouth Series (FMS) Acquisition Interface. See “Full Mouth Series (FMS) Acquisition Interface Overview” on page 14.
- CS 7600 Image Acquisition Software
 - Full Mouth Series (FMS) Acquisition Interface. See “Full Mouth Series Image Acquisition Interface” on page 28.

Single Image Acquisition Interface Overview

You can acquire individual images using the CS Imaging Software.

Figure 1 CS Imaging with Active CS 7600 Scanner Connected



Full Mouth Series (FMS) Acquisition Interface Overview

The Full Mouth Series (FMS) is a static representation of the mouth of the patient using a series of intraoral images. The images are placed in fixed numbered frames.

Figure 2 CS Imaging Software FMS Acquisition Interface

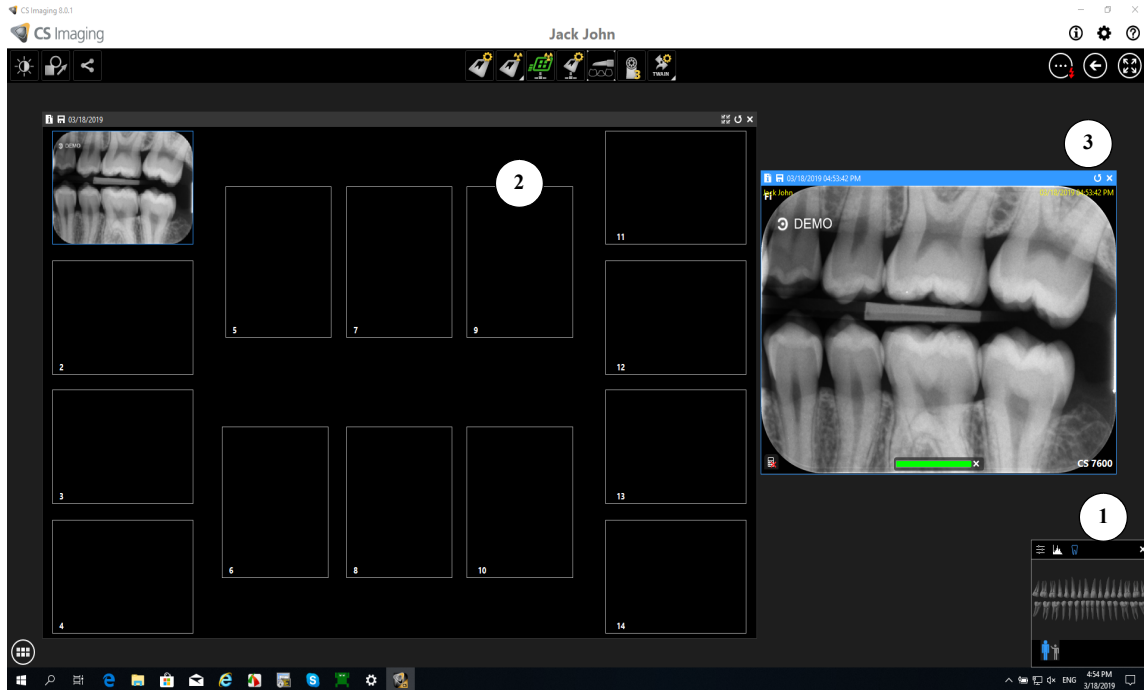

- ① **Dental arch:** Highlights the acquisition zone.
- ② **FMS template:** Displays frame templates for acquisition.
 - Green highlight: Frame ready for new acquisition
 - Blue highlight: Frame in the revue and retake mode. This mode interrupts the automatic acquisition sequence.
- ③ **Preview screen:** Displays the currently acquired image.

Figure 3 FMS Select a Format

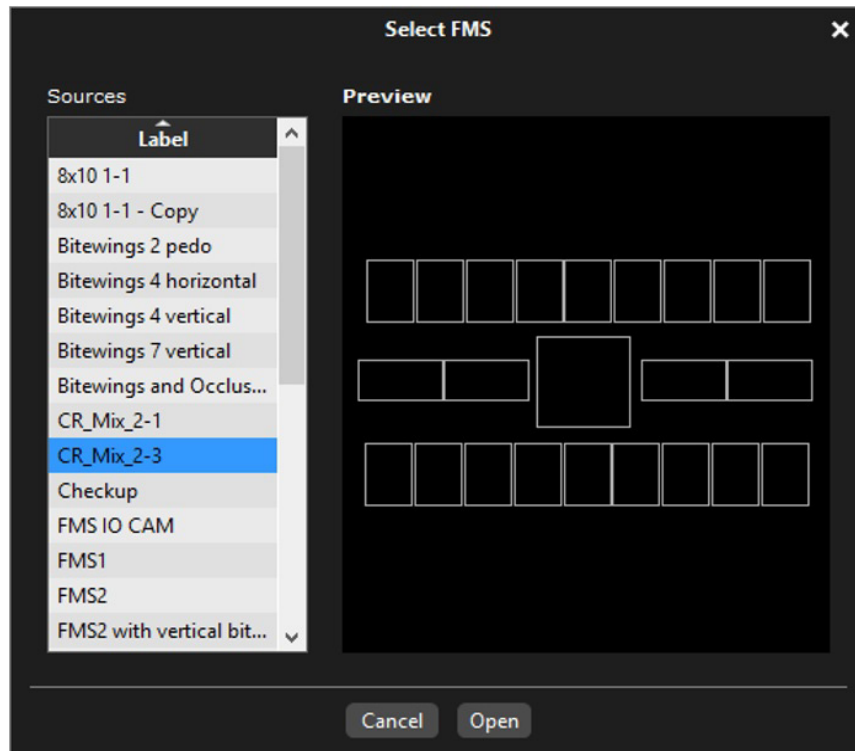

Select a Format enables you to select FMS template options to select for acquisition. You can modify existing templates and create new templates (see the *Carestream CS Imaging Software Online Help*).



Note: Only FMS templates for CR images can be used. Using other FMS will cause images not to be displayed.

Figure 4 Control Panel with CS Adapt Buttons

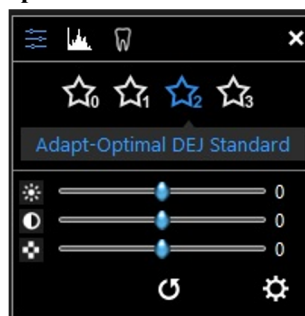

Control Panel: enables you to adjust the brightness and contrast of the image. For more information on Control Panel functions, see the *CS Imaging Software Online Help*.



CS Adapt Library: Opens the CS Adapt Library software that allows to manage your filters.



Adapt - Unfiltered Perio: Enhances the display of periodontal tissue.



Adapt - Unfiltered Endo1: Enhances contrast at the canals and roots (produces brighter images).



Adapt - Unfiltered DEJ1: Optimizes contrast at crowns, amelo-dentinal junctions, and roots (produces brighter images).



















Adapt - OptimizedContrastEndo: Enhances contrast at the canals and roots.

Figure 5 Image Toolbar and Drawings & Annotations Toolbar











Image toolbar: enables you to adjust the image display. For more information on Image toolbar functions, see the *Carestream CS Imaging Software Online Help*.





		Zoom icon: click to magnify a specific region.
		Highlight: click to optimize contrast within a region of interest.
		90° rotation: click to rotate the image by 90° clockwise.
		Flip: click to rotate the image by 180° clockwise.

		Mirror icon: click to create a mirror image of the original image.
 Colors icon group		Colors #1 icon: click to replace grays by a color
		Colors #2 icon: click to replace grays by sepia colors
		Grayscale icon: click to replace colors by grays
 Density icon group		Crop image: click to access the Crop panel. Cropping is not permanent and can be undone at any time.
		Isodensity dots: click to apply color to pixels of the same bone density.
		Densitometric analysis: click to analyze bone density.
 Filter icon group		Relief filter: click to enhance the outlines of the shapes in an image by displaying the image in relief mode.
		Pseudo - 3D: click to display gray scale levels as height values.
		Logicon icon: In RVG images, click to launch the Logicon Caries Detector to detect interproximal caries. Note: This tool is only available if you have the Logicon Caries Detector software installed.
		Negative icon: click to apply an inverse video effect to an image.
		Cosmetic module icon: click to add cosmetic treatments to color images. Note: This tool is only available if you have the Cosmetic Imaging Module software installed.
		Cephalometric Tracing icon: click to launch the automatic cephalometric tracing tool. Note: This tool is only available if you have the Tracings Module software installed.

Drawing and Annotations toolbar: contains icons for functions that you can apply to a selected image.

		Select icon: use this tool to select a drawing or measurement that you want to modify. The first mouse click selects the object, and the second mouse click shows the control points.
--	---	--

 Drawing icon group		Straight line icon: click to draw a straight line on an image.
		Multi-segment line icon: click to draw multi-segment line on an image.
		Freehand line icon: click to draw a freehand line on an image.
		Spline drawing icon: click to draw a spline curve that is basically a freehand line that has editable points.
		Circle icon: click to draw a circle on an image.
		Ellipse icon: click to draw an ellipse on an image.
		Filled ellipse icon: click to draw an ellipse on an image.
		Rectangle icon: click to draw a rectangle on an image.
		Filled rectangle icon: click to draw a filled rectangle on an image.
		Landmark point icon: click to add a point on an image.
		Arrow line icon: click to draw an arrow on an image.
 Measurements icon group		Straight line measurement icon.
		Multi-segment line measurement icon
		Angle measurement icon
		Orthogonal measurement icon
		Text icon
 Implant icon group		Mandibular canal icon
		Implants icon

	Calibration icon
	Undo icon
	Redo icon
	Delete icon
	Color and Thickness icon

CS Imaging Software Main Toolbar

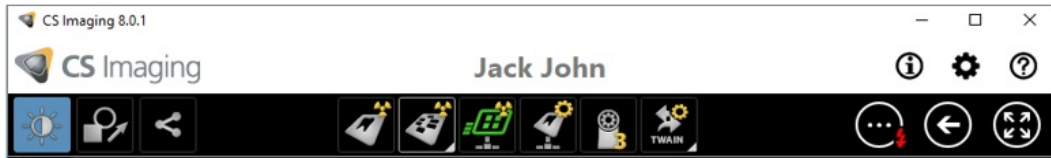

Scanner Status Indicator: shows the status of the active scanner. The following status options are available:

- **Green:** ready to scan.
- **Yellow:** blinks when tagging a plate and when a new image is transferred to CS Imaging Software.
- **Red:** error in the active scanner.
- **Grey:** active scanner is not connected.



CS 7600-Configure: click to open the CS 7600 configuration window. See “[CS 7600 Configuration Window](#)” on page 20.



New CR image: click the arrow button to select between the two options:

- CS7600 acquisition (CR)
- CS7600 FMS acquisition (CR2). After the option is selected, click to open the CS 7600 Image Acquisition Software in the FMS mode. See “[Full Mouth Series Image Acquisition Interface](#)” on page 28.

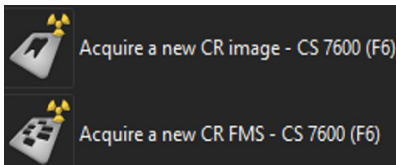

CS 7600 Configuration Window

The CS 7600 configuration window is opened when clicking the CS 7600-Configure button on the CS Imaging Software main toolbar.

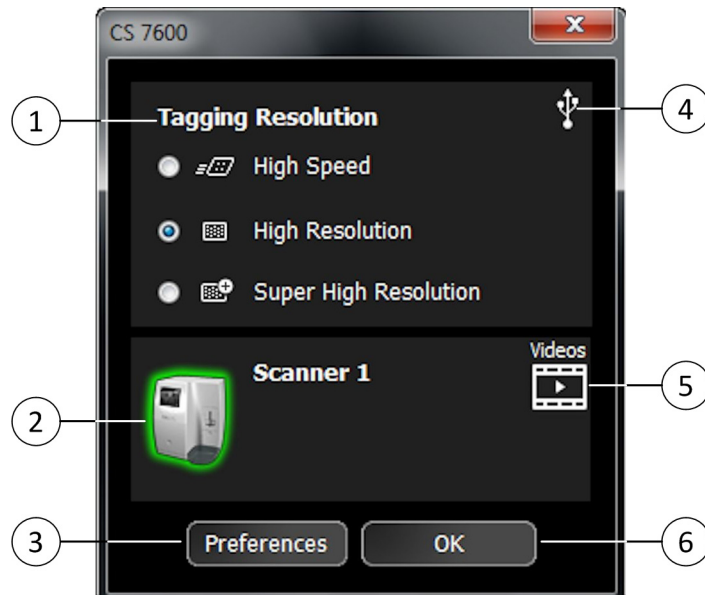

- ① **Tagging Resolution:** select one of the three available resolutions for the next tagging resolution. Available only if Scan&Go is connected.
- ② **Scanner Status Indicator:** Displays the status of the active scanner.
 - Green highlight: scanner is ready for operation
 - Grey: active scanner is not connected.
 - Red: active scanner error.
- ③ **Preferences:** click to open the CS 7600 Preferences window.
- ④ **Scan&Go Status Indicator:** Displays the status of the Scan&Go device.
 - White: Scan&Go device is connected.
 - Grey: Scan&Go device is not connected.
- ⑤ **Videos:** click to open the training videos.
- ⑥ **OK:** click to save the selected settings and close the CS 7600 configuration window.

4 Scanner Interface Overview

This chapter explains the scanner interface and how to use it.

Computer System Requirements



Important: It is MANDATORY to check that the computer system configuration is compatible with the computer minimum system requirements specified in the Safety, Regulatory & Technical Specifications User Guide. If necessary you must update your computer system configuration.

CS 7600 Scanner Interface Overview

The CS 7600 scanner interface is used primarily for scanning the exposed imaging plates and provides easy-to-understand prompts.

The scanner interface also provides the option of changing the scanner default settings as described in the CS 7600 installation guide.

All scanner functions are applied using the three buttons beneath the LCD.

The functional buttons are used for navigating the LCD screens, menus and used to apply your selections.







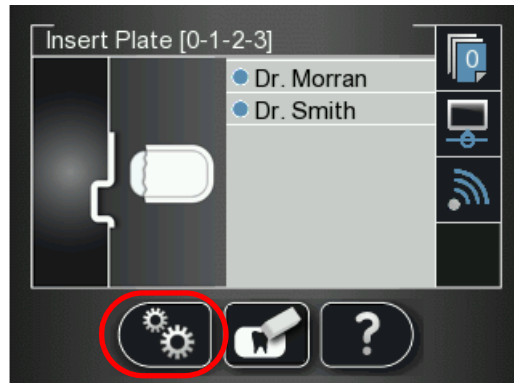



Scanner Interface Icons

Figure 1 Example of Insert Plate screen



The following table lists the icons that are part of the various LCD screens.

	Stored images counter and available memory status. Blue background indicates available scanner memory.
	Stored images counter and available memory status. Red background indicates scanner memory is either nearing its full capacity or is already used up.
	Network connection state, connected.
	Network connection state, disconnected.
	Network connection state, limited connection.
	Scanner is Paired (connected Peer to Peer) to a workstation.
	Scan & Go state indicator. Blue indicates the scanner supports Scan & Go smart scanning. When scanning recorded imaging plates this icon blinks.
	Scan & Go state indicator. White indicates the scanner does not support Scan & Go smart scanning, or that the scanned imaging plate does not contain Scan & Go recorded information.

Scan resolution

The image scan resolution



High speed (HS)



High resolution (HR)



Super high resolution (SHR)



Press the scanner's left function button to access the Settings menu. For information about Settings, See ["Repeat steps 1 to 4 for any other imaging plates that need erasing.."](#) on page 26



Press the scanner's middle function button to manually erase the imaging plate, See ["Erasing the Imaging Plates"](#) on page 26.



Press the scanner's middle function button to return to the Insert Plate screen.



Press the scanner's right function button to access scanner information such as scanner name, IP address and total scans performed by the system, and the system's set date and time.



Press the scanner's left function button to scroll down/forwards.



Press the scanner's right function button to scroll up/backwards.



Press the scanner's right function button to Unpair the scanner from the workstation.



Press the scanner's right function button to confirm your selection.



From SP4 you can delete images from the scanner using the Viewer, Press the scanner's right function button to delete the image being viewed.



To change the scan resolution for the current exam acquisition (when acquiring images without Scan & Go device), press the right scanner function button and toggle to the required scan resolution after inserting the imaging plate. (If another exam acquisition is selected, the scanner reverts to its default resolution.)



Image number in the Plate Viewer



Plate size (in the Plate Viewer)

Working with the Scanner

The following procedures are explained here:

- Turning on the Scanner, See “Turning on the Scanner” on page 24
- Image Acquisition, See “Image Acquisition” on page 24
- Scanner Info, See “Scanner Info” on page 25
- Erasing the Imaging Plates, See “Erasing the Imaging Plates” on page 26

Turning on the Scanner

After turning on the scanner, you are presented with the Starting screen.

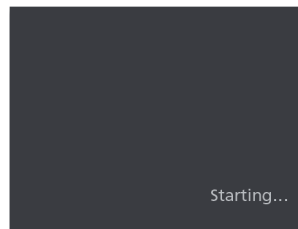

Then the Insert Plate screen opens.



The following three functions are presented:







-  Scanner Info, See “Scanner Info” on page 25
-  Erase Imaging Plate, See “Erasing the Imaging Plates” on page 26
-  Scanner Settings, See “Repeat steps 1 to 4 for any other imaging plates that need erasing..” on page 26

Image Acquisition

When image acquisition is performed without a Paired status or Scan & Go:

- 1 Press  to select a patient.
- 2 Press  to select a scan resolution.

- 3 Press  to scan the imaging plate.
The imaging plate is scanned.

For more information, See “Acquiring Single Image” on page 34

Scanner Info

- 1 Press  **Info**
The Scanner Info screen opens.



The following information is presented.

- System's set date and time
 - Scanner Name
 - IP address
 - Software Version
 - Scan Count: Total scans performed by the system
- 2 To close the **Scanner Information** screen, press 
The Scanner information screen closes and you return to the insert plate screen.

Erasing the Imaging Plates

The imaging plates are automatically erased and ejected after they are scanned. If the imaging plate is exposed to light for an extended period of time (one week or more) or to strong light for even a short amount of time, the plate will need to be manually erased before use.

To erase the imaging plate manually, follow these steps:

- 1 Press  the scanner's middle function button
- 2 The LCD displays the **Erase plate** screen:

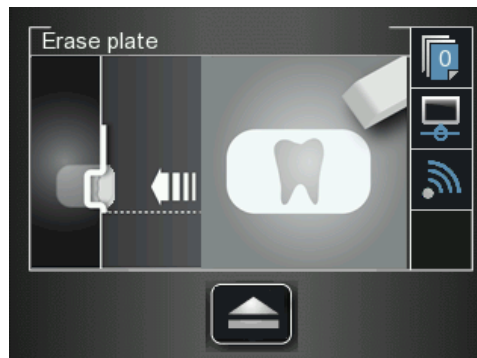

- 3 Insert the imaging plate into the scanner's insertion slot without the hygienic sheath (for information on how to insert the imaging plate, See [“Inserting the Imaging Plate”](#) on page 35).

The Erase plate screen is displayed.

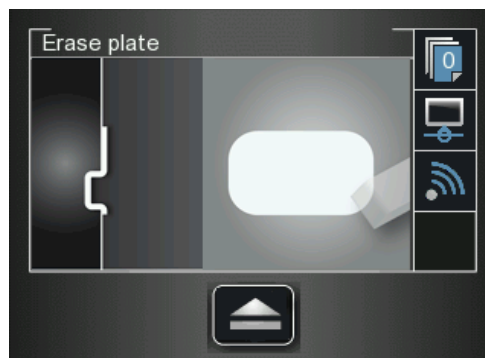

The erased imaging plate is ejected to the tray and the scanner reverts to the **Insert Plate** screen.

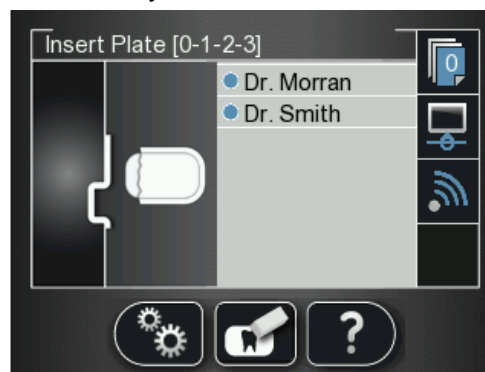

- 4 Collect the imaging plate while taking care to maintain hygienic protocol and minimal exposure to light.
- 5 Repeat steps 1 to 4 for any other imaging plates that need erasing..

5 CS 7600 Image Acquisition Interface

CS 7600 Imaging Software Overview

The Imaging Software is a user-friendly working interface that was designed and developed specifically for radiological diagnosis. It is the common imaging platform for all our digital systems for dentistry.

The Imaging Software provides management of the patients and image database.

To open your Imaging Software: On your desktop, double-click the Imaging Software icon or click **Start > All Programs > Carestream > CS Imaging software**.

For more information, see your Imaging Software documentation.

CS 7600 Image Acquisition Interface Overview

The CS 7600 image Acquisition interface is a user-friendly application designed and developed specifically for the CS 7600 intraoral imaging system. It provides a rich array of image processing options in addition to the acquisition functions.

The image Acquisition interface provides one mode:

Full Mouth Series: Full series of frames, according to one of the available industry standard templates for full mouth series, selected in the **General Settings** tab.

Full Mouth Series Image Acquisition Interface

Figure 1 Image Acquisition Interface - Full Mouth Series Mode

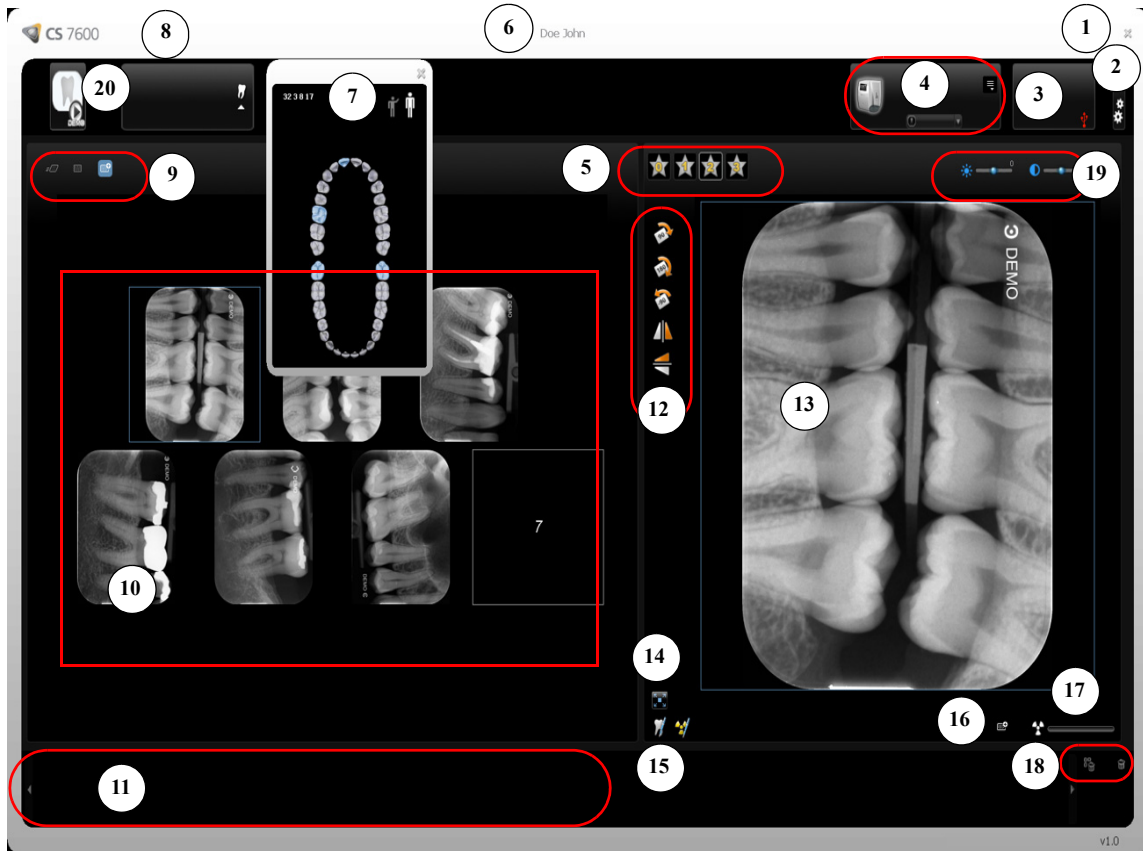

Scanner List

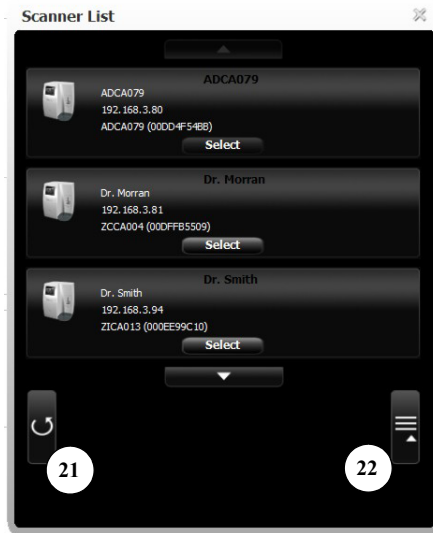

 **Tip:** Selected and active options are highlighted in blue.

Table 1 Image Acquisition Interface Key















1	Exit	Click  to exit the CS 7600 image Acquisition interface.
2	Settings	Click  Settings to customize the default settings. See “Working with Settings” on page 55..
3	Scan & Go Status	<p>The Scan & Go’s active connection status (white color indicates connection, red indicates no connection).</p> <p> USB (connected)  USB (not connected)</p>
4	Scanner Area	<p>Allows browsing of all active connected scanners (if there are multiple scanners in the same network).</p> <p>Click  Scanner List to list all scanners.</p> <p> Green frame indicates a connected scanner</p> <p> Grey frame indicates a disconnected scanner</p> <p> Red frame indicates a scanner in error state (click the scanner icon to display the error tool tip)</p> <p>Click  the arrow, to display the images in the memory of the selected scanner. To retrieve the required image, please pull the image to Images Display Area</p>
5	Favorite Filters Buttons	<p>Click to enhance a different zone of interest:</p> <p> Click to enhance the display of periodontal tissue.</p> <p> Click to enhance contrast at the canals and roots (produce brighter images).</p> <p> Click to optimize contrast at crowns, amelo-dentinal junctions, and roots.</p> <p> Click to enhance contrast at the canals and roots.</p>
6	Patient Information	Displays the patient information.
7	Tooth Selection	<p>FMS or Image Acquisition template.</p> <p>When using an FMS template, the tooth associated with the selected frame is highlighted blue in the panoramic arch icon.</p> <p>When using Image Acquisition, clicking the arrow (under the Toothpicker icon) allows selecting individual teeth in either child  or adult  dentitions. (To clear the selection, click the tooth again.)</p>

Table 1 Image Acquisition Interface Key

























8	Imaging Software Details	Clicking the  CS 7600 CS 7600 Icon provides the imaging software details.
9	Scan Resolution	<p>The scan resolution to apply when tagging information on an imaging plate with the Scan & Go device. To change the scan resolution for the current exam acquisition, click the required icon before you tag the imaging plate:</p> <p> High Speed (HS)</p> <p> High Resolution (HR)</p> <p> Super High Resolution (SHR)</p>
10	Images Display area	This area displays the images according to one of the dental standard layouts determined by the Default template selection in the “General Settings Tab” tab.
11	Images Gallery	Useful for storing images when rearranging the layout, or for discarding an image when necessary.
12	Orientation Buttons	<p> Click to rotate the selected image 90 degrees clockwise.</p> <p> Click to rotate the selected image 180 degrees.</p> <p> Click to rotate the selected image 90 degrees counter clockwise.</p> <p> Click to flip the selected image vertically (Mirror inversed images).</p> <p> Click to flip the selected image horizontally (Mirror inversed images).</p>
13	Preview Panel	Displays the active frame’s image (if frame is populated). You may apply the processing and comments to the preview image.
14	Full Screen	 Click to display the image in a separate, full screen window (dark room mode)
15	Comments & Exposure Values	<p> Click to add a comment to the image (The comments will be added to the DICOM tags of the image and can be viewed later using the Imaging Software or DICOM viewer.)</p> <p> Click to enter custom X-ray exposure values. This information is inserted in the image’s DICOM header. Otherwise the default exposure values as defined in the “General Settings Tab” are inserted in the DICOM header.</p>

Table 1 Image Acquisition Interface Key

16	Selected Image Resolution	<p>Indicates the selected image's resolution level (in the preview image panel):</p> <div style="display: flex; align-items: center; margin-bottom: 5px;">  <div style="margin-left: 5px;">High Speed (HS)</div> </div> <div style="display: flex; align-items: center; margin-bottom: 5px;">  <div style="margin-left: 5px;">High Resolution (HR)</div> </div> <div style="display: flex; align-items: center;">  <div style="margin-left: 5px;">Super High Resolution (SHR)</div> </div>
17	X-ray Exposure Indication	<p>Partly red, indicates an underexposed image. Review the X-ray technique and consider increasing the exposure values for better image quality and diagnosis.</p> <div style="display: flex; align-items: center; margin-bottom: 5px;">  </div> <p>Green, indicates good exposure values.</p> <div style="display: flex; align-items: center; margin-bottom: 5px;">  </div> <p>All red, indicates that the image is over exposed. Review the X-ray technique and consider lower exposure values for better image quality and diagnostics.</p> <div style="display: flex; align-items: center;">  </div>
18	Delete	<p>Click to delete ALL images from the Images Gallery.</p> <div style="display: flex; align-items: center; margin-bottom: 5px;">  </div> <p>Click to delete the selected image from the Images Gallery.</p> <div style="display: flex; align-items: center;">  </div>
19	Image Brightness and Contrast	<p>Use the brightness slider to manually adjust the image's brightness.</p> <div style="display: flex; align-items: center; margin-bottom: 5px;">  </div> <p>Use the contrast slider to manually adjust the image's contrast.</p> <div style="display: flex; align-items: center; margin-bottom: 5px;">  </div> <p>Click to apply an automatic optimization of brightness and contrast.</p> <div style="display: flex; align-items: center;">  </div>

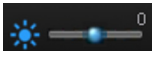
 **Tip:** Image Brightness and Contrast may also be adjusted by holding the mouse button over the image and dragging vertically, for contrast, and horizontally, for brightness.



20	Demo Mode	<p>Populates one frame in the images display area with a demo image each time the icon is selected.</p> <div style="display: flex; align-items: center; margin-top: 10px;">  </div>
21	Refresh	<p>Click to refresh the Scanner List.</p> <div style="display: flex; align-items: center; margin-top: 10px;">  </div>
22	Close Scanner List	<p>Click to close Scanner List.</p> <div style="display: flex; align-items: center; margin-top: 10px;">  </div>

Image Acquisition Interface

When you open the Dental Image Software or CS7600 Image Acquisition Software for the first time, the following window opens.



- 6 Click **OK**.

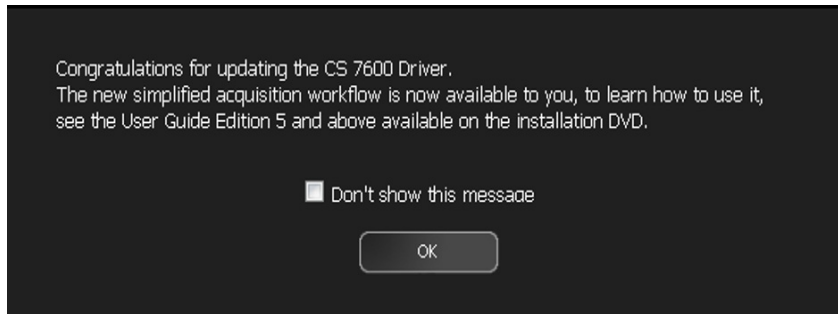

Note: Do not select the **Don't show this message again** checkbox.

The **Image Adjustment** window opens.

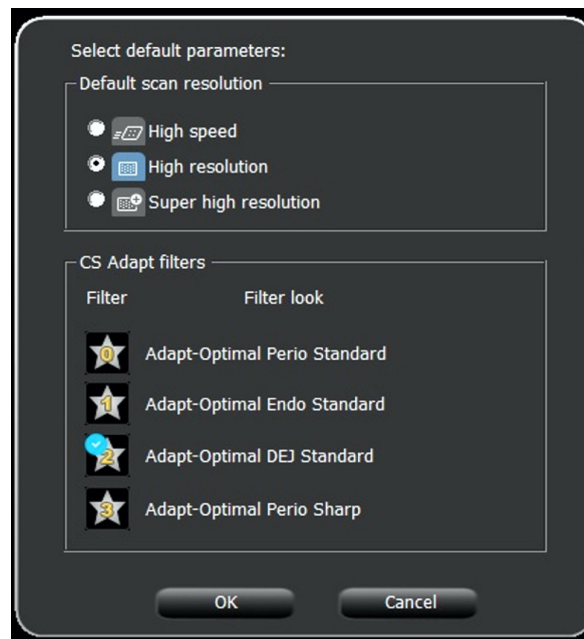

- 7 Select a default scan resolution check box.
- 8 The filter number with blue check mark will be applied to the next image acquisition.
- 9 To change this settings, click **OK** and open the **CS Adapt** to modify.

6 Acquiring Images without Scan & Go

Introduction

This chapter describes the acquisition procedure for configurations with and without the optional Scan & Go device.

A typical work-flow consists of the following steps:

- Accessing the imaging window, See [“Starting the Imaging Software”](#) on page 34
- Preparing the Imaging Plates, See [“Preparing the Imaging Plates”](#) on page 35
- Inserting the Imaging Plate into a hygienic sheath and sealing it, See [“Inserting the Imaging Plate”](#) on page 35
- Placing the imaging plate in the patient’s mouth behind the selected tooth or teeth, See [“Performing the X-rays”](#) on page 36
- Exposing the imaging plate to X-ray, See [“Performing the X-rays”](#) on page 36
- Removing the imaging plate from the patient’s mouth, See [“Performing the X-rays”](#) on page 36
- Disinfecting the Hygienic Sheath, See [“Disinfecting the Hygienic Sheath and the Imaging Plates”](#) on page 69
- Scanning the Imaging Plate, See [“Retrieving a Fallen Imaging Plate”](#) on page 81
- Storing the image in the CS Imaging Software, See [“Storing the Images”](#) on page 48

Acquiring Single Image

Starting the Imaging Software

- 1 On your desktop, double-click the Imaging Software icon or click **Start > All Programs >** (the name of your) **CS Imaging Software**.
- 2 Create or open an existing patient record:
 - **To open an existing patient record:** In the Patient Browser search field (**H**), start typing to search for a patient card.

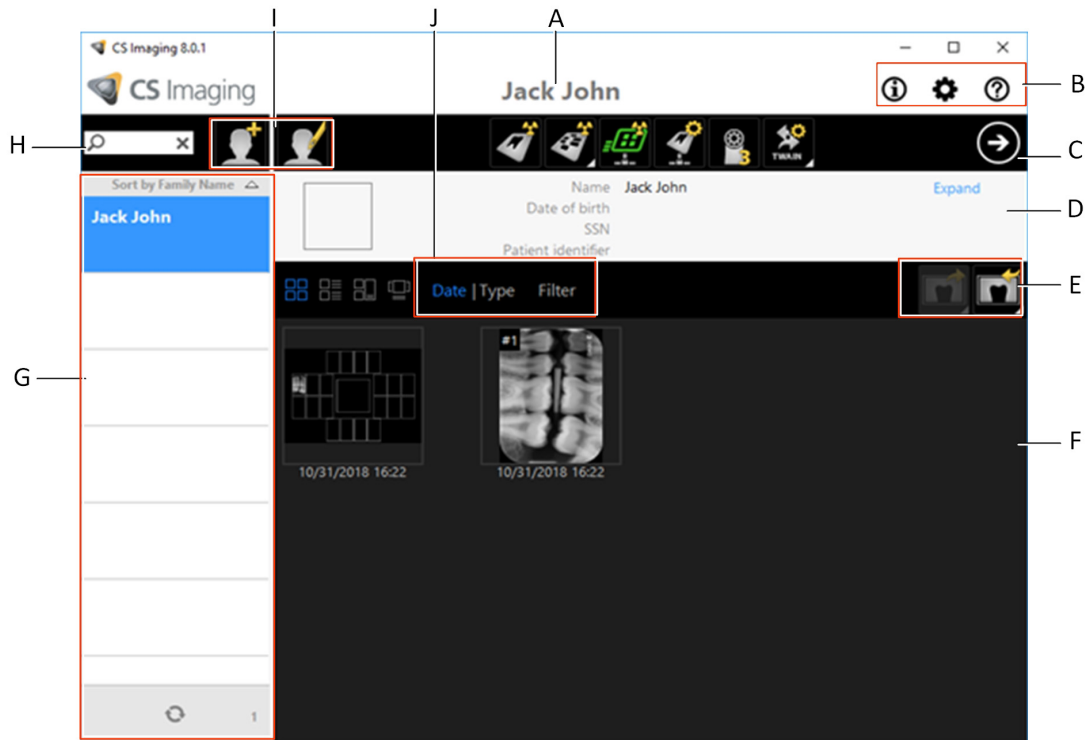

- **To create a new patient record:** Click the **Create New Patient Card** button alongside the search field to create a new patient card. For more details.
3. Once you have selected or created a patient, in the Patient Browser Toolbar (**C**) click the arrow button to open the Imaging application. The Patient Browser window remains open and the Imaging Window is displayed.
 4. Wait for the Scanner Status icon to turn green on the **Imaging Window** toolbar indicating that the CS 7600 scanner is connected to the workstation and is ready for acquisition.

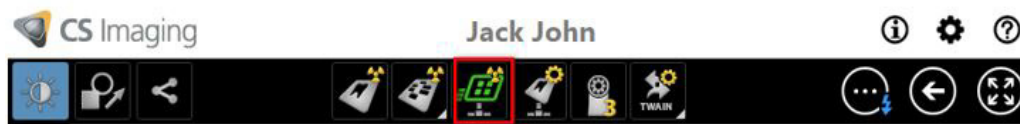

The newly created patient becomes an existing patient. Click **Patient > Find**, select the newly created patient from the list and click the Imaging Software button to proceed.

Preparing the Imaging Plates

To prepare the intraoral imaging plate, follow these steps:

- 1 Choose an imaging plate of the right size for your examination.



Important: Use only CS 7600 intraoral imaging plates from Carestream Dental and hygienic sheaths from Carestream Dental. The use of plates or hygienic sheaths from a third party supplier may cause a malfunction of the system and void the warranty.



Tip: If the imaging plate has not been used for a while, proceed to erase it first. See “Erasing the Imaging Plates” on page 26.



Important: If you select a size 4 imaging plate, make sure the scanner has the size 4 insertion slot panel installed. For information on replacing the insertion panel, See “Cleaning the Detachable Insertion Panels” on page 70. There is no need to power off the system when replacing insertion panels.

Inserting the Imaging Plate

- 2 Insert the disinfected imaging plate (See “Disinfecting the Hygienic Sheath and the Imaging Plates” on page 69) into its protective hygienic sheath with the inactive side facing the adhesive strip, so the imaging plate’s size number is seen through the transparent side of the hygienic sheath and the orientation dot is visible in the bottom corner (A).
- 3 Peel the adhesive strip’s protective paper to seal the hygienic sheath (B).
Handle the imaging plate by holding the hygienic sheath’s empty edge (C) (where the foam strip is).



Performing the X-rays

Perform the required X-rays according to your clinical procedure.

It is recommended to continue using X-ray positioning techniques and tools to ensure the resulting image is complete and includes all the information required for diagnosis. It is recommended to use the Rinn Suresoft holder or equivalent products available on your market. To facilitate matching the orientation of the image in the software to the clinical reality, we recommend to position the imaging plate in the mouth of the patient with the orientation mark always towards the bottom.



Important: Make sure the active side of the imaging plate is facing the patient's teeth.

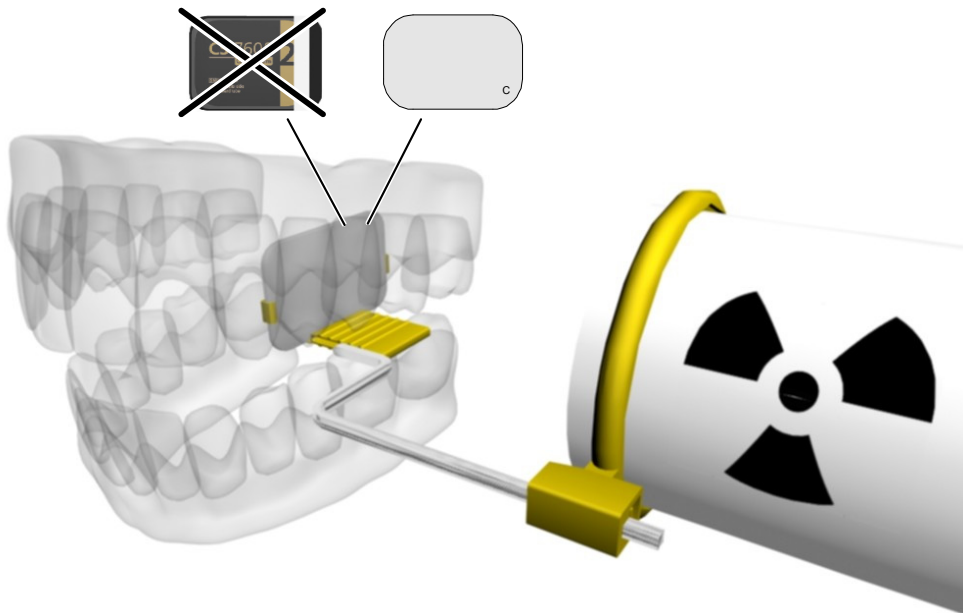

Scanning the Imaging Plates

- 1 Remove the imaging plate from the patient's mouth. **Do not remove the imaging plate from its hygienic sheath.** Wipe and disinfect the exposed imaging plate's hygienic sheath (See "Disinfecting the Hygienic Sheath and the Imaging Plates" on page 69). Keep the imaging plate in its hygienic sheath to minimize exposure to light.

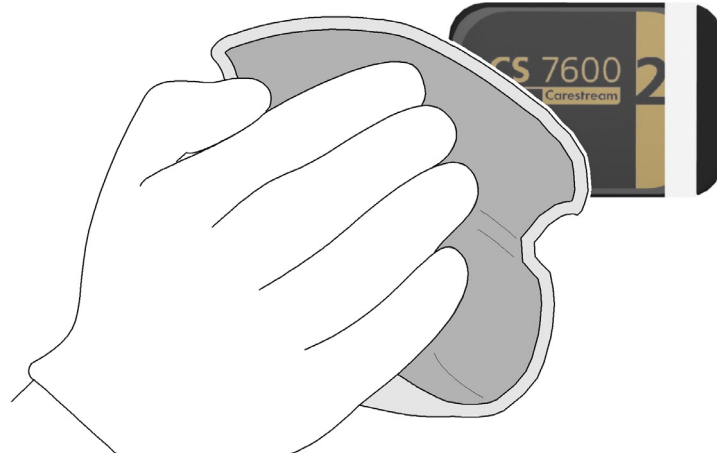

Important: If the imaging plate is exposed to light, it could result in degradation of image quality. Do not remove the imaging plate from its hygienic sheath until you insert it in the scanner's insertion slot.

- 2 At the scanner location, tear open the hygienic sheath (A) and insert the exposed imaging plate into the scanner by positioning the open side of the sheath in the insertion panel slot (B) with the foam side to the right. Push out the tip of the imaging plate from its hygienic sheath (C). The imaging plate (without its protective sheath) is drawn into the insertion slot by the scanner and the scanner preview shows the scan progress.

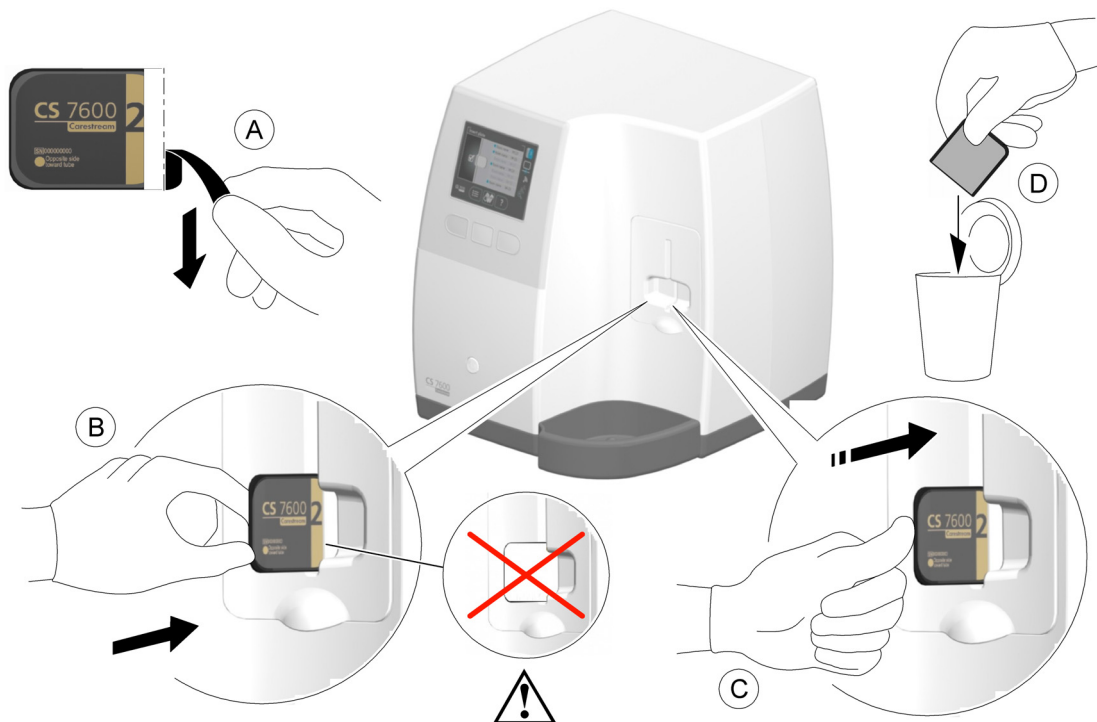



Important: If the user inserts the plate incorrectly, there is a possibility of the plate falling into the scanner. If the plate falls into the scanner, See “Retrieving a Fallen Imaging Plate” on page 81

- 3 Dispose of the used protective hygienic sheath (D).

If the scanner is linked Peer to Peer with a workstation, the image is sent automatically to the workstation which it is linked with.

- 4 Select the patient from the list. If the required patient does not appear in the list, select the NO ID option.



Note: For information on retrieving the NO ID images, See “Clearing Scanner Memory” on page 64

- 5 Press the  middle function button to scan the imaging plate.

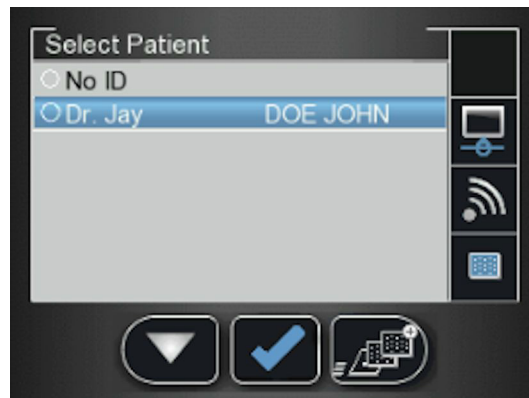

- 6 Collect the ejected imaging plate from the lower tray after it is scanned, insert it into a new envelope, seal the envelope and store it into the storage box for next use.



Important: After scanning the image, the scanner erases the imaging plate before ejecting it. The imaging plate is ready for re-use.

- 7 Check the image quality.

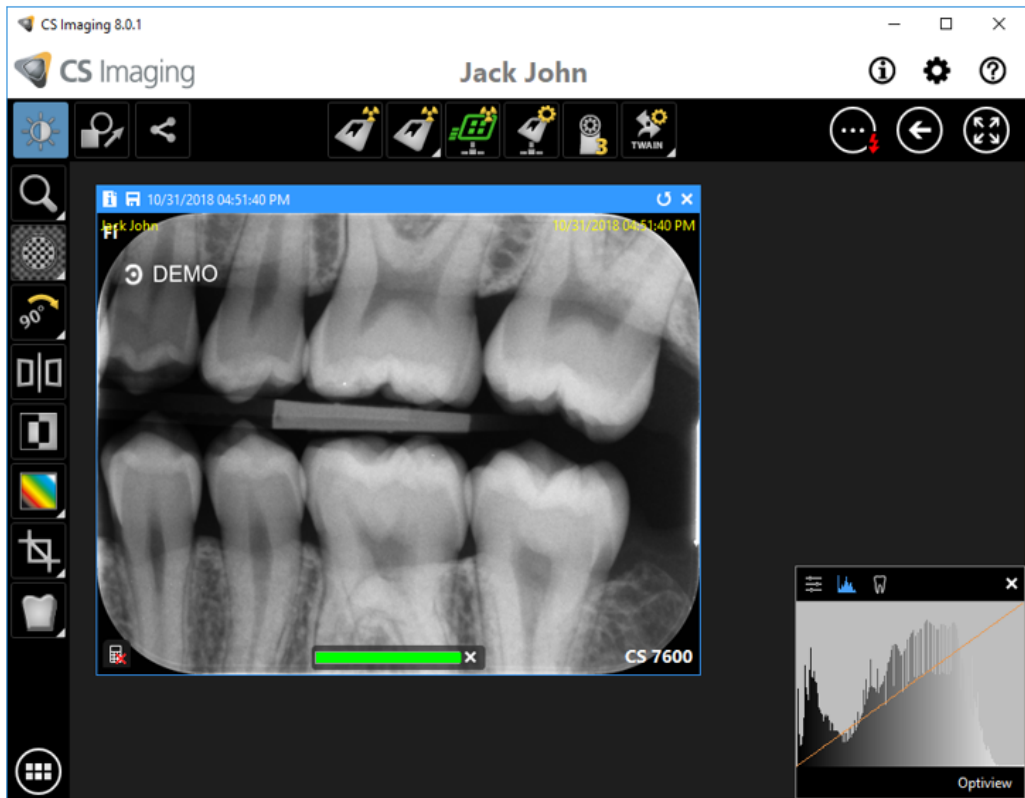

The ideal image quality is when the indicator of the quality of exposure is a full green bar in the Control Panel. Avoid under-exposed or over-exposed images indicated by a partial or full red bar.

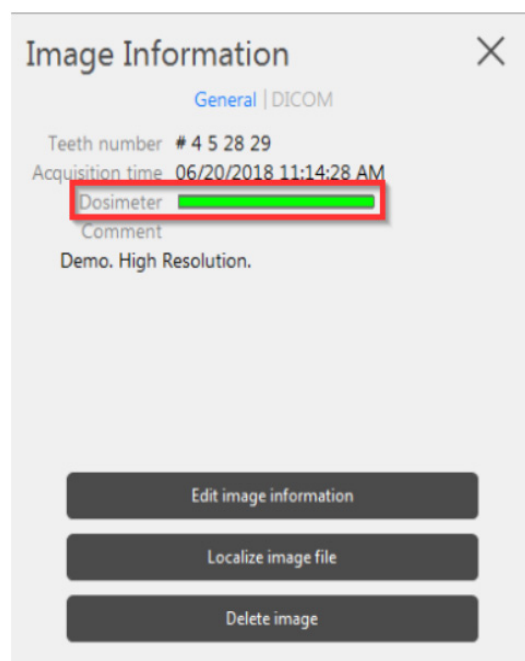
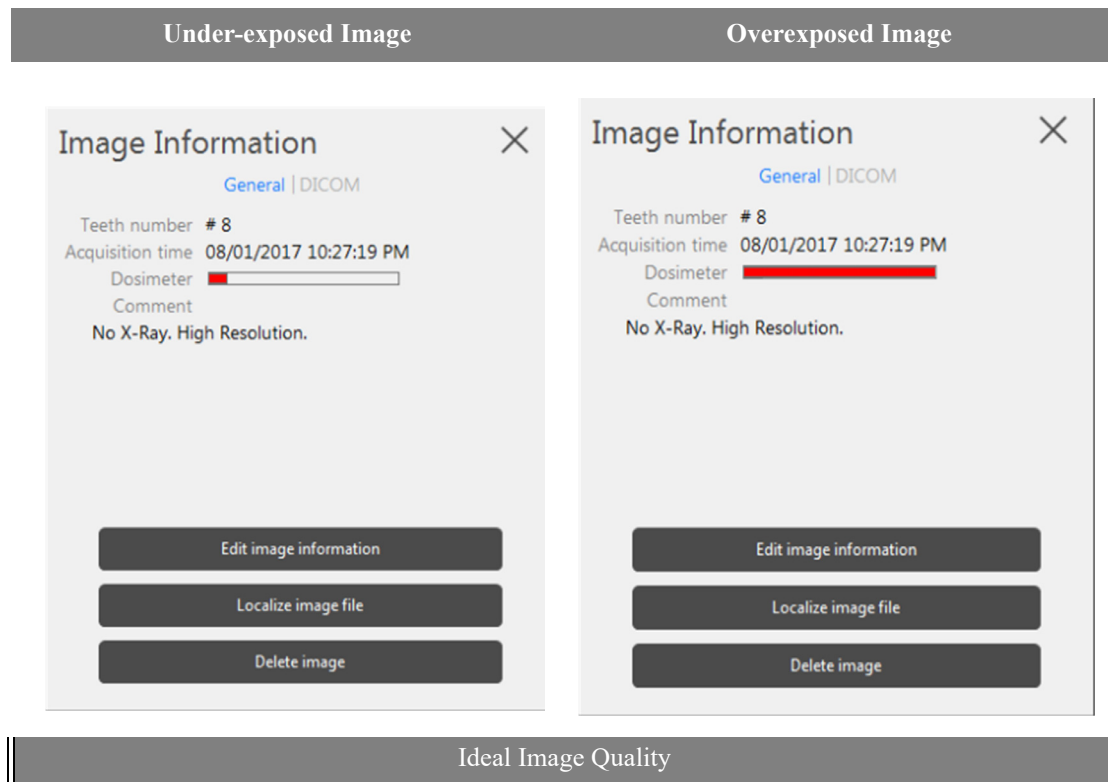

Acquiring Multiple Images

Preparing Acquisition of FMS Images

To prepare the acquisition of FMS images, follow these steps:

- 1 Access the **CS Imaging Software**. See “**Starting the Imaging Software**” on page 34
- 2 Click **New Image Template** to access the **Select a format** window.

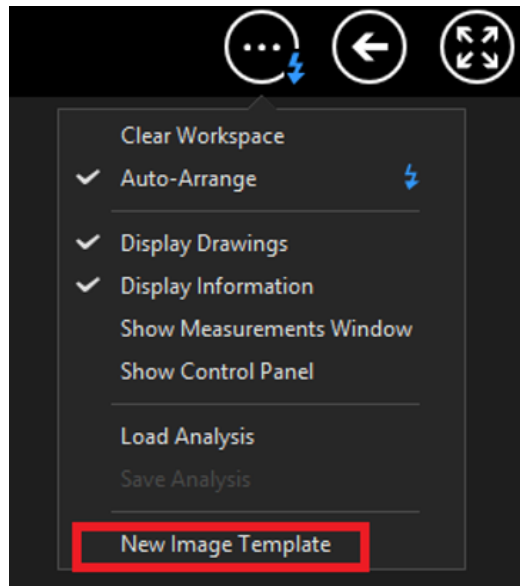

- 3 From the list of available formats (templates), select the required template and click **Open**.

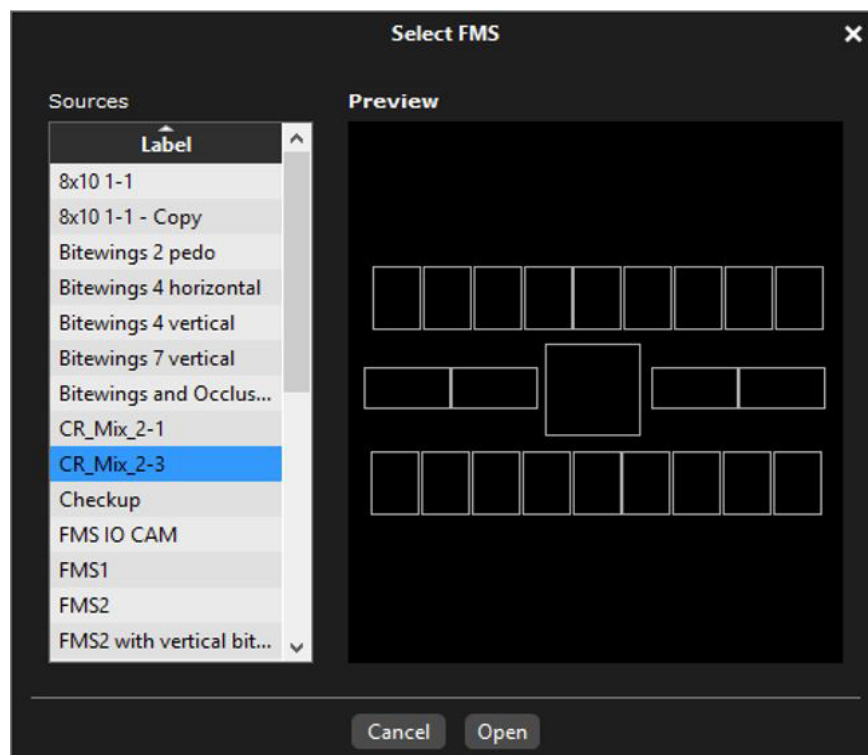

If you try to change the FMS template after you have finished your image acquisitions you are prompted with a warning that indicates that you risk loosing some of the images.



The selected format is loaded and displayed in the Dental Imaging window. The first frame for scan is highlighted in green.

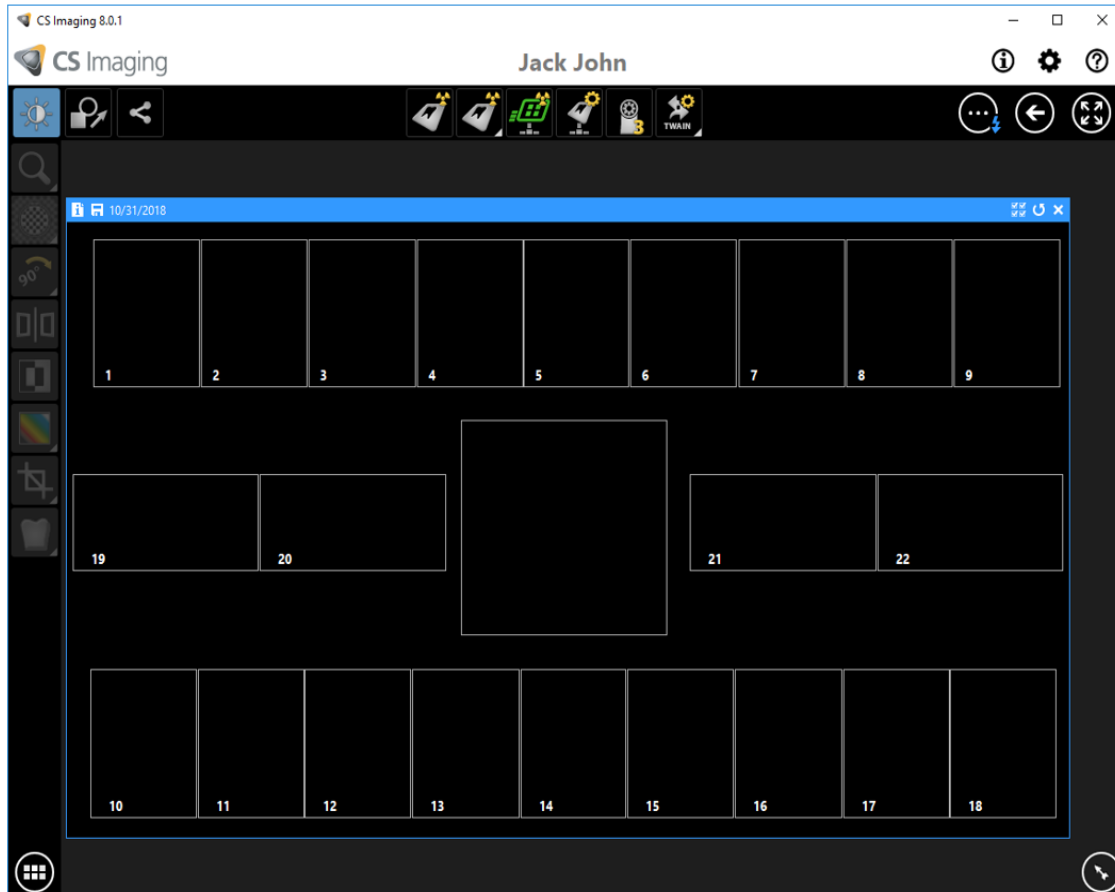

7 Acquiring Images Using Scan & Go

Introduction

This chapter describes the acquisition procedure for configurations with the Scan & Go device.



Note: Using the Scan & Go option streamlines and shortens the scanning process. The scanned image reaches its destination automatically; no need to select the destination workstation when scanning the imaging plate. In FMS mode, the image automatically populates its designated frame in the template.

A typical workflow consists of the following steps:

- Accessing the imaging window, See [“Starting the Imaging Software”](#) on page 34
- When working with multiple images, selecting or [“Opening the Image Acquisition Interface”](#) on page 46
- Preparing the Imaging Plates, See [“Preparing the Imaging Plates”](#) on page 35
- Tagging the imaging plate with the Scan & Go, See [“Tagging the Imaging Plate with the Scan & Go”](#) on page 44
- Placing the imaging plate in the patient’s mouth behind the selected tooth or teeth, See [“Performing the X-rays”](#) on page 44
- Exposing the imaging plate to X-ray, See [“Performing the X-rays”](#) on page 44
- Scanning the Imaging Plates, See [“Scanning the Imaging Plates”](#) on page 44
- Removing the imaging plate from the patient’s mouth, See [“Performing the X-rays”](#) on page 44
- Disinfecting the Hygienic Sheath, See [“Disinfecting the Hygienic Sheath and the Imaging Plates”](#) on page 69
- Reviewing the scanned image on the image Acquisition interface, See [“Processing the Images.”](#) on page 47
- Storing the image in the CS Imaging Software, See [“Re-tagging Imaging Plates”](#) on page 48

Acquiring Single Image Using Scan & Go



Note: Keep the image Acquisition interface open throughout your exam acquisition session: close it only after you have completed scanning and optimizing all images.

Starting the Imaging Software

Start your Imaging Software. See [“Starting the Imaging Software”](#) on page 34.

Preparing the Imaging Plates

Prepare the intraoral imaging plate. See “Preparing the Imaging Plates” on page 35

Tagging the Imaging Plate with the Scan & Go

To tag the imaging plate using a Scan & Go device follow these steps:

- 1 Place the imaging plate near, or close to, the Scan & Go device to record the exam acquisition data. The image Acquisition interface marks the corresponding frame as recorded (frame color changes to indicate recorded status).
 - For Scan & Go devices before June 2012, an audible beep and two successive blinks of the blue LED indicate the exam acquisition information was recorded.
 - For Scan & Go devices after June 2012, two audible beeps and two successive blinks of the green LED indicate the exam acquisition information was recorded.

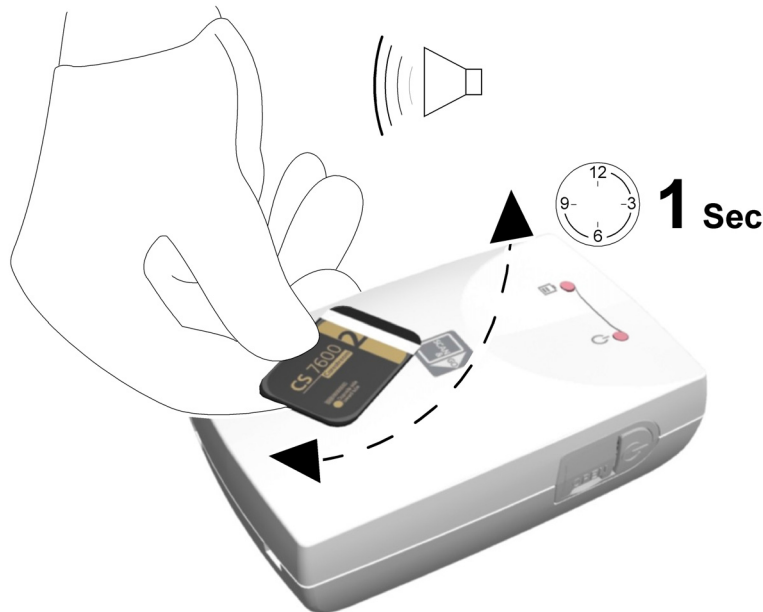

- 2 Perform steps 1 for each imaging plate.



Tip: To display the imaging plate’s tagged information at any time, place the imaging plate on top of the Scan & Go device and check the Imaging plate Scan & Go information in the **Settings**-Imaging plate information tab.

To record exam acquisition data on an imaging plate that was already recorded, See “Acquiring Multiple Images (FMS) Using Scan & Go” on page 46

Performing the X-rays

Perform the required X-rays according to your clinical procedure. See “Performing the X-rays” on page 36

Scanning the Imaging Plates

To scan the imaging plates:

- 1 Perform steps 1 -3 of the “Scanning the Imaging Plates” on page 37



Note: After the imaging plate has been scanned, the image is sent straight to the previously assigned workstation.

- 2 Perform steps 6 - 7 of the “Scanning the Imaging Plates” on page 37

Acquisition Related Procedures

See “Processing the Images.” on page 47

Acquiring Multiple Images (FMS) Using Scan & Go

Starting the Imaging Software

Start your Imaging Software. See “Starting the Imaging Software” on page 34.

Opening the Image Acquisition Interface

- 1 Click the Imaging window icon. (Alternatively, double-click the selected patient name.) The patient’s imaging window opens.
- 2 To access the Image Acquisition Interface, select one of the following two modes:

CS 7600 FMS mode (Template mode), examples of the icons 

- 3 To change the scanning resolution for this exam acquisition (for non Scan & Go configurations), go to the scanner resolution setting (see page 57).
 - Verify that the Scan & Go device is connected.

Preparing the Imaging Plates

Prepare the intraoral imaging plate. See “Preparing the Imaging Plates” on page 35

Tagging the Imaging Plate with the Scan & Go

“Tagging the Imaging Plate with the Scan & Go” on page 44

Performing the X-rays

Perform the required X-rays according to your clinical procedure.

Scanning the Imaging Plates

After the imaging plate has been scanned, it is sent to the previously assigned workstation to the proper frame it was tagged to in the FMS.

See “Scanning the Imaging Plates” on page 37

Acquisition Related Procedures

See “Processing the Images.” on page 47

8 Acquisition Related Procedures

Processing the Images.



Important: The imaging plate has a marker attached to its inactive side. It will indicate if the imaging plate has been exposed from the wrong side contrary to its intended use. If the shadow of the marker is visible in the X-ray image, the imaging plate was exposed from the inactive side contrary to its intended use. The image orientation can be corrected using the mirroring tool in the acquisition software. If a diagnosis is not possible in the area of the marker, the X-ray should be repeated.

Figure 2 Image Acquisition Interface

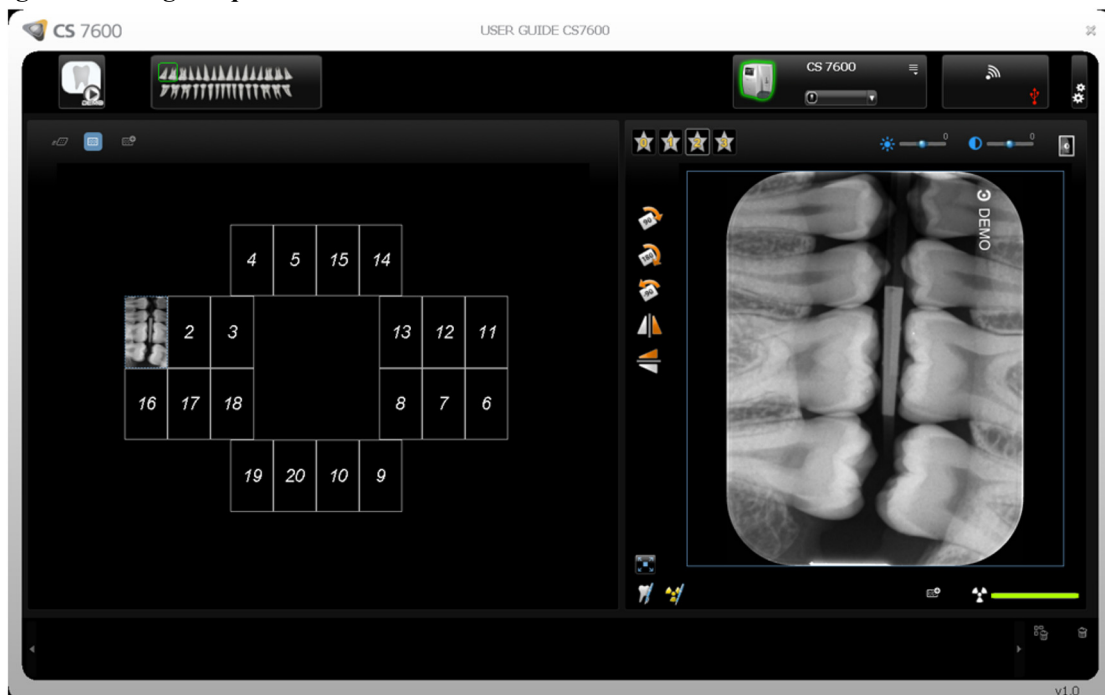

To process the scanned images, from your workstation follow these steps:

- 1 The scanned image populates the first available frame. If there is no such frame (all frames are occupied, applicable only when working with FMS mode), the image is routed to the Images Gallery. In image acquisition mode, a new frame is added to the images layout.

For manual reordering of the frames, drag and drop the image to the desired frame. If the frame is populated with an image, the former image in the frame will be moved automatically to the Images Gallery when the new image is dropped within it.



Note: When exiting the image Acquisition interface, images stored in the Images Gallery are sent to the Imaging Software database.

- 2 Use the image Acquisition interface processing options to optimize the image. See “CS 7600 Image Acquisition Interface Overview” on page 27.

- 3 Click **✕ Close** (top-right corner) to exit the image Acquisition interface and return to the Imaging Software. Images are transferred from the CS 7600 image Acquisition interface to the Imaging Software automatically.

Re-tagging Imaging Plates

To tag an imaging plate that was already recorded with exam acquisition information (re-tagging), follow these steps:

- 1 Place the imaging plate upon the Scan & Go device. The following prompt is displayed.

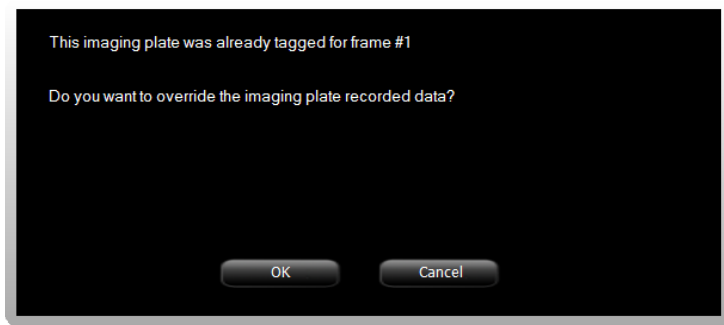

- 2 Click **OK** to re-tag this imaging plate.
The imaging plate is tagged with the current exam acquisition and the current active frame information. If you do not want to re-tag the imaging plate, either remove the imaging plate from the Scan & Go surface or click **Cancel** in the overwrite prompt. The current tagged data as displayed in this prompt remains unchanged.
- 3 Wait until the exam acquisition information tagging is completed as indicated by an audible beep, successive short flashes of the blue LED and a change of color in the frame border and number.

Storing the Images

Image management (storage and retrieval) is performed through the Imaging Software. See your CS Imaging Software documentation.

Clearing Scanner Memory

When the CS 7600 image Acquisition interface is open at the designated workstation, the scanned imaging plate image is automatically routed to the correct exam acquisition.

If the CS 7600 image Acquisition interface is closed, the scanned imaging plate image is stored in the scanner's memory. The scanner's storage capacity is 25 images.

To clear the scanner's memory, See [“Clearing Scanner Memory” on page 64](#).

Erasing the Imaging Plates

The imaging plates are automatically erased and ejected after their information is scanned. Exposure to light and so forth, requires erasing manually the imaging plates before use. To erase the imaging plate manually, See “Erasing the Imaging Plates” on page 26.



Note: Erasing the imaging plate manually does not erase the recorded exam acquisition information.

9 Scanner Settings

General

The following scanner settings are explained in this chapter:

- Brightness Control, See “Brightness Control” on page 52.
- IP Setup, See “IP Setup” on page 52.
- Rollers Cleaning, See “Cleaning the Scanner Rollers” on page 73.
- About Information, See “Scanner Info” on page 25.
- Viewer, See “Viewer” on page 54.
- Pairing, creates a direct PC to scanner link for chair-side use, See “Creating a Peer to Peer Connection” on page 62. and See “Disconnecting a Peer to Peer Connection” on page 63.
- Clearing Scanner Memory, See “Clearing Scanner Memory” on page 64.

Scanner Settings



To open the scanner settings, press  **Settings**.
The Scanner Settings menu opens.





In Scanner Settings menu you are presented with the following menu:

- **Brightness Control**, See “Brightness Control” on page 52.
- **IP Setup**, See “Clearing Scanner Memory” on page 64.
- **Rollers Cleaning**, See “Cleaning the Scanner Rollers” on page 73.
- **About Information**, See “Scanner Info” on page 25.
- **Viewer**, See “Viewer” on page 54.
- **Pairing**, allows you to create a Peer to Peer (P2P) link between a scanner and computer. See “Creating a Peer to Peer Connection” on page 62. and See “Disconnecting a Peer to Peer Connection” on page 63.

Brightness Control

- 1 In the Settings menu, press  to select **Brightness Control**, and press . The Brightness Control screen opens.



- 2 Press  and  to lower or raise the brightness, and press . The Brightness is set and you are returned to the scanner insert plate screen.

IP Setup



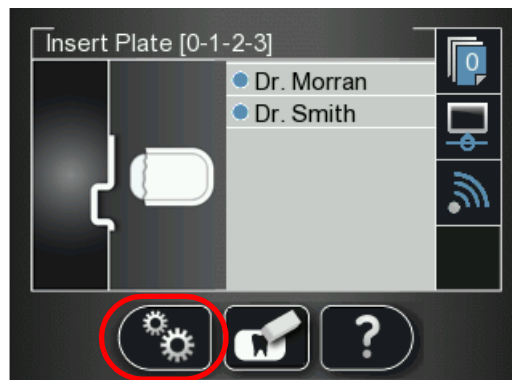

Important: Do not perform any action in the IP Setup without direct supervision from dental service engineer or Carestream Dental representative.

To manually set the scanner's IP address, follow these steps:



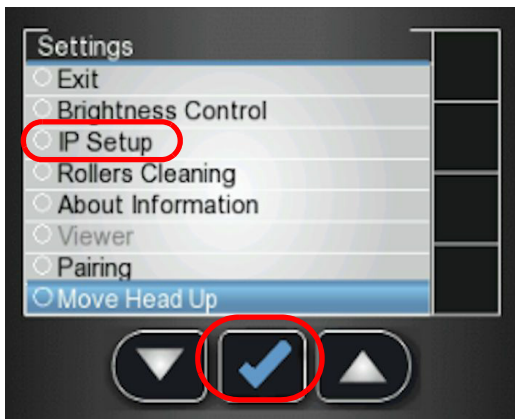





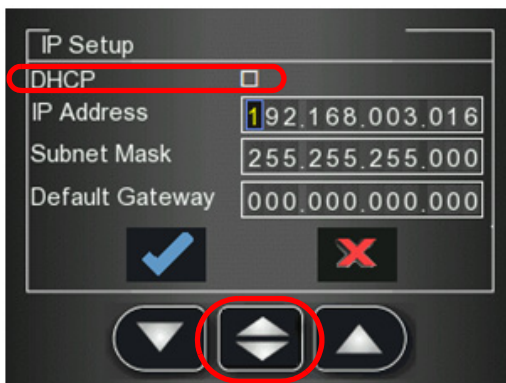





- 1 Press  to access the **Settings** menu.
The **Settings** screen is displayed.





- 2 Press  the scanner's left function button to scroll down to **IP Setup** and press .
The **IP Setup** screen is displayed.



Note: The **DHCP** automatically detects the scanner IP address. If you are using a Peer to Peer link, you must leave the **DHCP** checkbox **unchecked**.

- 3 Press  and  to find the **DHCP** checkbox, and press  to check / un check the **DHCP** checkbox.
- 4 Press  and  to reach the digit you wish to change, and press .
- 5 Press  and  to increase / decrease the value of the selected digit, and press .
- 6 Navigate to the next digit you need to change and change it according to the above instructions.
- 7 To apply all changes and exit the **IP setup** screen, press  to reach  (highlighted in blue) and press .



- 8 To exit the **IP Setup** screen without saving changes, press  to reach  (highlighted in blue) and press . The IP Setup screen closes and you are returned to the scanner insert plate screen.

Viewer

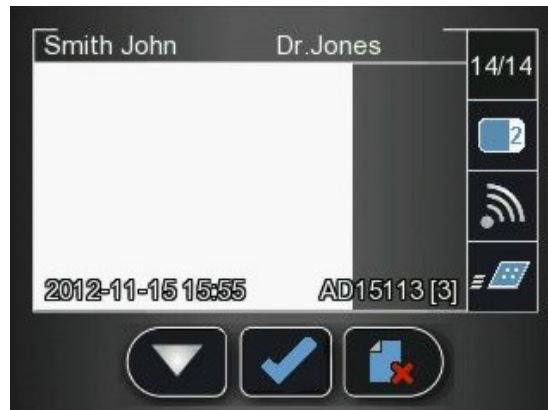

The Viewer allows you to browse and delete images archived on the scanner's memory.

- 1 In the Settings menu, press  to select **Viewer**, and press . The **Viewer** screen opens.

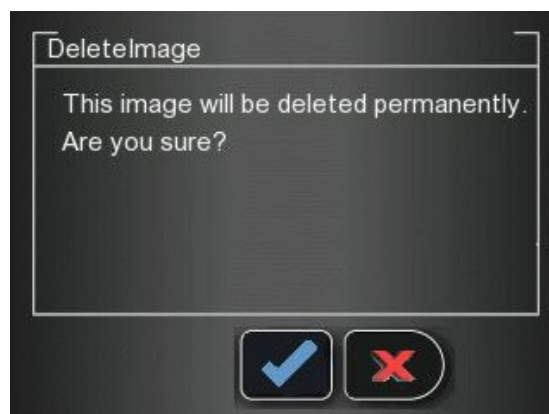

- 2 In the Viewer menu, press .
- 3 If you reach an image that you wish to delete, press  the delete icon. A Delete Image confirmation window appears.



- To delete, press .
 - To cancel the deletion, press .
- 4 To close the Viewer, press .

Working with Settings

To open the settings window, click  **Settings**.

You are presented with three tabs:

- **General Settings**, See page 57
- **Scan & Go**, See page 59
- **Scanners Connections**, See page 60

General Settings Tab

In the **General Settings** tab you are able to set the defaults for image Acquisition.

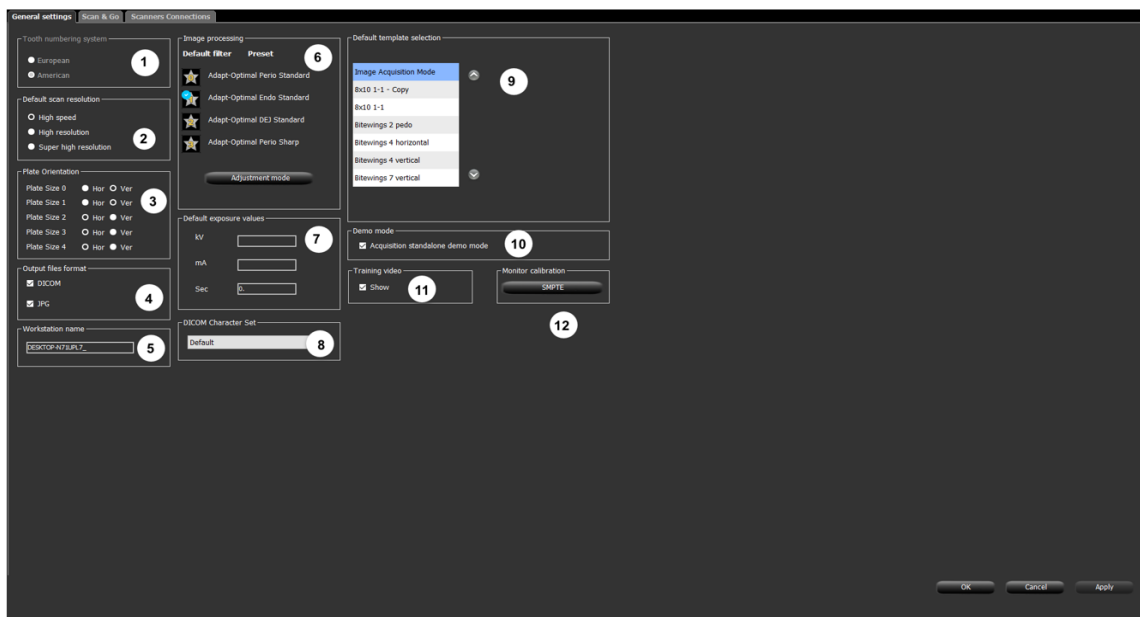



Table 1 Image Acquisition Interface General Settings Key

1	Tooth Numbering System	Set the tooth numbering system (European or American). When using individual tooth selection, the tooth number is stored in the image's DICOM tags.
2	Default Scan Resolution	Set the default scan resolution for images to be scanned. Note: This does not change the scanner's default resolution, which is for images scanned when the image Acquisition interface is not connected to the scanner (No ID images). The scanner's default resolution is High Speed. Note: Any changes made in the image Acquisition interface, when the scanner is linked Peer to Peer to the image Acquisition interface, automatically changes the scan resolution in the scanner.
3	Default Orientation	Set the default plate orientation vertical or horizontal to ensure correct orientation.
4	Output Files Format	The scanned image save file format. Scanned images are always saved as DICOM files and there is an option to save the scanned image also in JPEG format.
5	Workstation Name	If needed, change the workstation name by entering the new name.
6	Image Processing	<p>Default filter and Preset:</p> <p>Set the default filter to be applied to the acquired image. (The installation default is Endo). The image processing is managed by the CS adapt (see 8J6395 CS 7600 Installation Guide).</p> <ul style="list-style-type: none">• Perio (Periodontal) filter: Designed to assist in detecting disease or inflammation in the interface between the gum (gingival part) and the bone.• Endo (Endodontic) filter: Provides overall good contrast and look of the image, with a high quality view of the root canals. It reveals any diseases or injuries that affect the root tips or nerves in the teeth.• DEJ (dentine to enamel junction) filter: Designed to improve the contrast resolution between the dentine and the enamel. It enables the dentist to detect small carries and evaluate the inspected region. <p>Preset enables setting a default image processing filter presets that are applied after the image is acquired.</p> <ul style="list-style-type: none">• Sharp: Sharpening filter for the sharpest look, contrast transition emphasis.• Soft: Soft look, smooth transition from high to low density.• Standard: Intermediate processing, between sharp to soft. <p>Adjustment mode: Imaging processing adjustment mode enables setting the optimal filter and preset combinations for each filter type.</p> <p>Note: If you acquire images in Adjustment mode, they are saved under the patient in the imaging software database.</p>
7	Default Exposure Values	Enter the default X-ray exposure values to added to all scanned images attributes (DICOM tags).
8	DICOM Character Set	Note: Only your IT Administrator should change these settings. Select the correct DICOM character set encoding for the country and area to ensure the information is rendered correctly on DICOM viewers.
9	Default Template Selection	Set the template used when opening a new exam acquisition, or to change the current template (applicable to a newly opened acquisition session ONLY, before images have been retrieved from the scanner.)

Table 1 Image Acquisition Interface General Settings Key

10 Demo Mode	This option puts  the Demo Mode icon in the top left corner of the Image Acquisition Window and populates one frame in the images display area with a demo image each time the icon is selected. Tip: Use for setting default presets in Adjustment mode.
11 Training Video	Select the check box to show the training video.
12 Monitor Calibration	Displays an SMPTE screen for monitor calibration.

Working with the General Settings Tab

To work with the General Settings tab:

- 1 Click  **Settings** to open the General Settings tab.
- 2 In the **Tooth Numbering System** area, select the **European** or **American** checkbox.
- 3 In the **Default Scan Resolution** area, select the default resolution for scanning.
- 4 In the **Default Orientation** area, select the direction that the image is to be turned, clockwise or counter clockwise.
- 5 In the **Output Files Format** area, select the **JPG** checkbox if you wish the images to be saved in JPEG format as well as the default DICOM format.



Note: In the **Output Files Format** area, the **DICOM** selection box cannot be de-selected.

- 6 To select a default scan resolution and CS-Adapt filters.
 - a In the **Default scan resolution** area, select High Speed, High Resolution or Super High Resolution for the scan resolution.

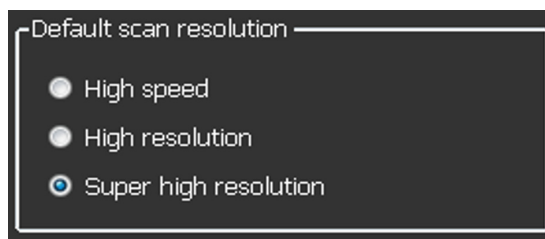

- b Click **Adjustment Mode** to change the default filter in CS-Adapt.

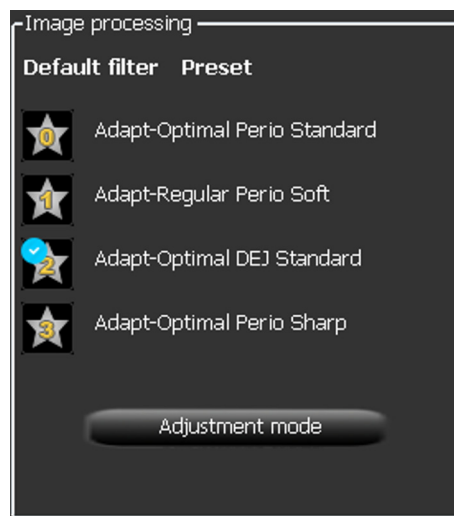

- 7 To display the SMPTE screen, in the Monitor calibration area click **SMPTE**. The SMPTE window appears.

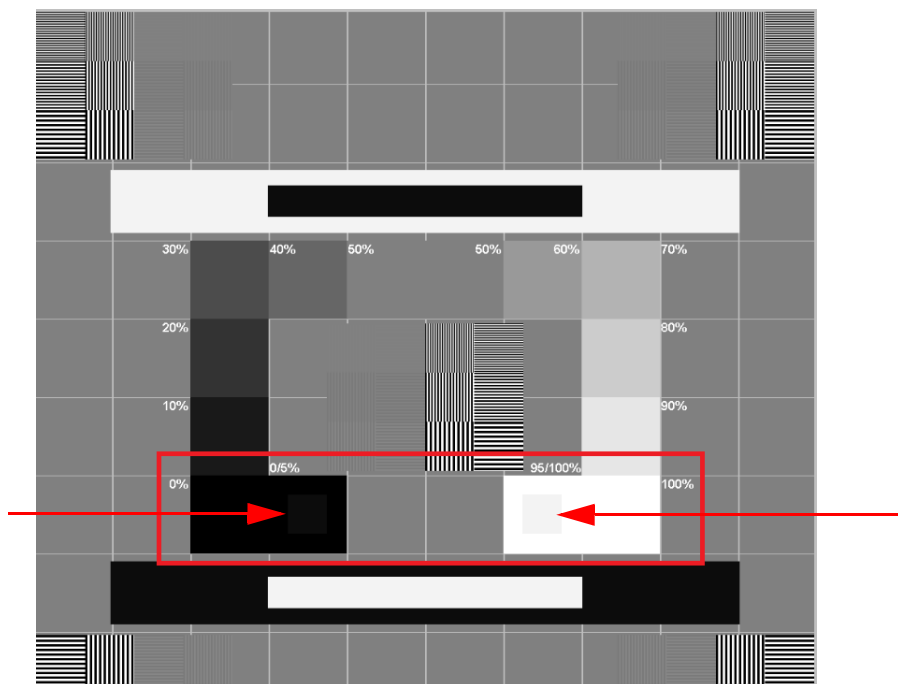

- 8 Use the monitor brightness & contrast controls until you clearly see the 5% and 95% calibration squares located in the in the 0% and 100% areas (indicated by red arrows in the picture above).
- 9 In the Settings tab, when you have finished selecting your general settings, click one of the following:
- Click **Apply** to apply your settings.
 - Click **Cancel** to exit to the main screen without saving changes.
 - Click **OK** to save the changes and exit to the main screen.



Scan & Go Tab

The Imaging plate Scan & Go information fields are populated with the imaging plate's identifying information when it is placed upon the Scan & Go device.

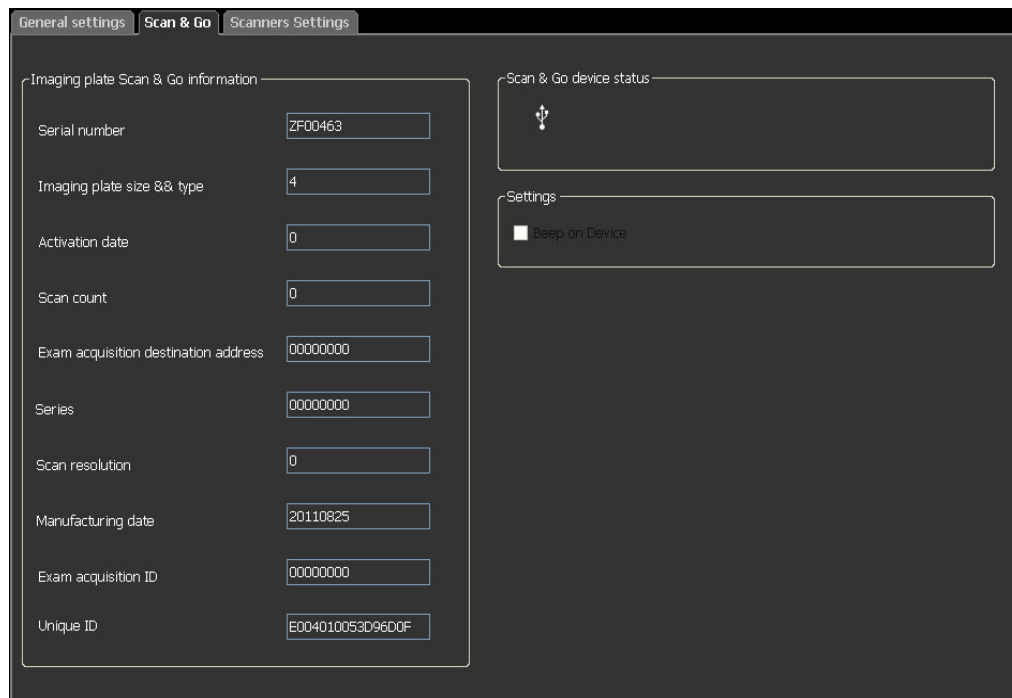
Figure 1 Scan & Go Tab



The Scan & Go tab contains the following information:

- **Serial Number**
- **Imaging Plate Size & Type**
- **Activation Date**, the date of the first time the plate was used
- **Scan count**, the number of times the plate has been scanned
- **Exam Acquisition destination address**
- **Series**, frame identification number
- **Scan resolution**
- **Manufacturing date**, the date the plate was manufactured
- **Exam Acquisition ID**
- **Unique ID**
- **Scan & Go device status**, shows if the Scan & Go is connected  (white icon) or not connected  (red icon)

- **Beep on Device** checkbox (for Scan & Go Generation 2), when the **Beep on Device** checkbox is selected, the Scan & Go makes a sound each time an imaging plate is tagged. If the Beep in PC checkbox is selected, a sound is made on the PC each time an imaging plate is tagged.



Note: The Imaging plate Scan & Go information in the **Scan & Go** tab is read only.

Scanners Connections Tab

In the **Scanners Connections** tab, you are able to perform the following:

- **Delete** a scanner connection that is no longer being used (after a scanner has been replaced)
- **Pair / Unpair** a Peer to Peer link between a Scanner and the Workstation
- **Connect / Ignore** a scanner from the active Scanner List
- Rearrange the Scanner List, by clicking the **Select** button which moves the scanner to the top of the Scanner List

Figure 2 Scanners Connections Tab

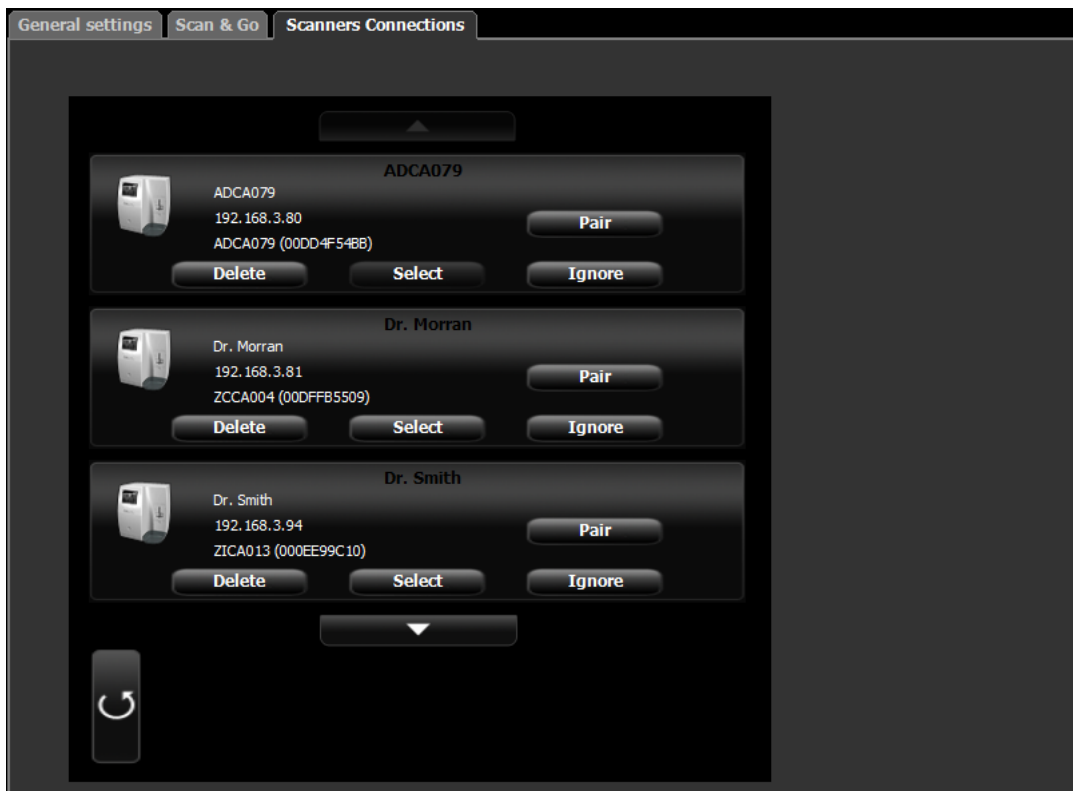

Working with the Scanners Connections Tab

- 1 To remove a scanner from the **Scanner List**, click **Ignore**.
- 2 To add a scanner to the **Scanner List**, click the **Connect** button for that scanner.



Note: If there are scanners on the network which you don't wish to use, click **Ignore**.

- 3 To completely remove a scanner that is no longer being used from the **Scanners Connections** and the image Acquisition interface, click **Delete**.



Note: Scanners connected to the system will still be detected and added to the list of scanners in the **Scanners Connections** list after restarting the image Acquisition interface.

- 4 In the image Acquisition interface, click one of the following:
 - Click **Apply** to apply your settings.
 - Click **Cancel** to exit to the main screen without saving changes.
- 5 Click **OK** to save the changes and exit to the main screen.





About Peer to Peer Connection

A Peer to Peer connection (P2P) creates a dedicated link between one, or more, scanners to a dedicated workstation. When a plate is scanned with a Peer to Peer connection, there is no need to select a Workstation/Room or press the middle scanner button. The scanner automatically scans the plate as soon as it is fed into the scanner and sends the image to the Paired workstation.



Tip: If your workstation is the only one using a particular scanner you can save time, not having to select a scanner each time you make a scan, by making a Peer to Peer link from the scanner to the computer.

There are four possible statuses for the Peer to Peer:

- **Available for Peer to Peer connection-** The scanner is available for a direct Peer to Peer connection. This status may be identified when  the **Pair** button is available.
- **Paired** - The scanner is connected Peer to Peer to this Workstation. This status may be identified when the  **Paired** message is shown and the  **Unpair** button is available.
- **Paired to Doctor x** - The scanner is already connected Peer to Peer to another Workstation
- **Unavailable for Peer to Peer-** This status is when a scanner in the Scanners list is not connected to your workstation or any other workstation and is not available for connecting to your workstation, this may be identified by the absence of  the **Pair** button,  **Paired**, and **Paired to** messages.



Note: The tagged Imaging plate is sent to the proper room, defined by Scan & Go, even when in Peer to Peer mode.