

Strip Lights with HDMI Sync Box

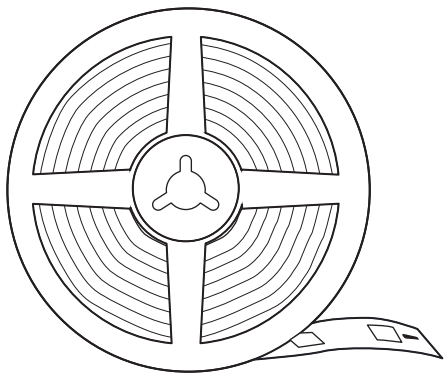

User Manual



Download Smart Life App

Smart Life App allows you to control and customize your controls for Strip Light via your smart device, Search for the latest version on Apple App store or Google Play.

CONTENTS

- 02 | IMPORTANT SAFETY INSTRUCTIONS
- 05 | GETTING TO KNOW SMART STRIP LIGHTS
- 10 | USING YOUR SMART STRIP LIGHTS
- 13 | TROUBLESHOOTING

IMPORTANT SAFETY INSTRUCTIONS

Read All Instructions Before Use And Save For Future Reference

This is an electric lamp – not a toy!
To avoid risk of fire, burns, personal injury and
electric shock it should not be played with or
placed where small children can Reach it

SAVE THESE INSTRUCTIONS

For any product problems or report an unexpected situation
during use, please contact the Customer Support at :
Support@ilifart.com

Getting to Know Smart Strip Lights

In The Box

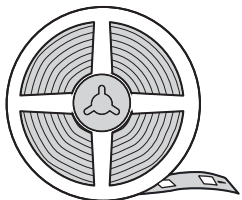

LED Strip Lights x1

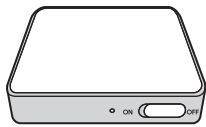

HDMI Sync Control Box x1



Power Adapter x1
For Sync Box



Fixing Clips x14

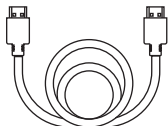

HDMI Cable x1
For HDMI Port

Specifications

Model	
Power Supply	AC 100-240V DC 12V \approx 2.0A
Power	Max 24W
LED	30 pcs / meter
Strip Light Length	12.5ft(3800mm)/16.4ft(5000mm)
Suitable TV Size	55-65 inch/75-85inch
HDMI	HDCP 2.2 Video resolution, Support to 4K@ 60Hz, HDR 10+
Wi-Fi	2.4GHz
Supported OS	Android 5.0 or iOS 9.0 and above
Bluetooth Protocol	4.0 and above
Voice Control	Alexa & Google Assistant

Installing Your Strip Lights



- DO NOT cut the strip light. Avoid bending in the position of LED components so as not to damage or affect the service life of the strip light.
- Remove nails, metal, or other conductive objects from the installation surface before attaching the strip light. Keep it clean and dry.

1. Tear off adhesive tape and firmly stick the strip light on (from the bottom left). Reinforce with clips around corners.
2. Connect strip light to control box, and then plug in the control box with adapter. Fix with adhesive if necessary.
3. Connect control box to sync box, and then plug in the sync box with adapter.
4. Connect Apple TV, Blu-Ray player or gaming console to HDMI IN port.
5. Connect HDMI OUT port to any output sources such as TV or monitor.

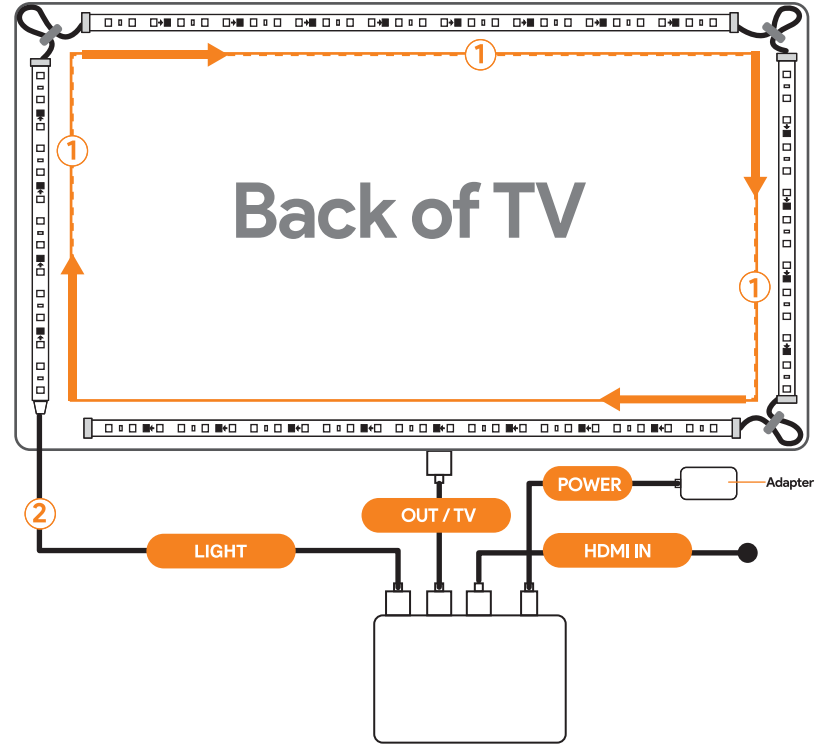

Connect Apple TV / Blu-ray Player / Gaming Console

Using Your Smart Strip Lights

Connecting with Smart Device

1. Download the "Smart Life" app from the APP Store or Google Play.
2. Register an account and allow the app to use Bluetooth.
3. Connect to 2.4GHz Wi-Fi network and turn Bluetooth on from you mobile phone.

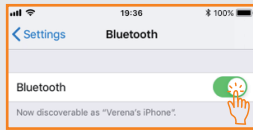
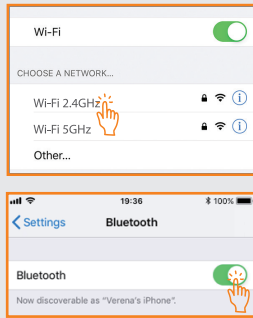
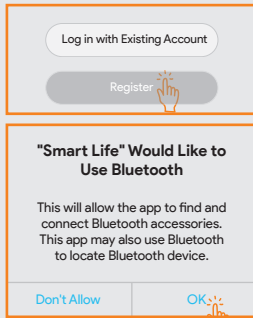

Tips

- If you have already downloaded the "Smart Life" App and registered the account, you can skip step1 and step 2.
- Please check your current APP version is 4.0.0(20220513162618) or above.

4. Charge and turn on power button of HDMI control box, the light flash and enter the pairing mode automatically. Please complete the network arrangement within 10 minutes and the light doesn't flash. To remove device or reset factory Settings, switch the device on and off for three times within five seconds until the light flash again, you can enter the pairing mode.

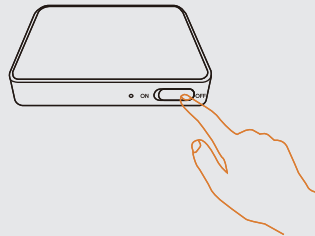

5. After completing the above operation instructions, open the Smart Life APP, "Devices to be added" will pop up on the Smart Life homepage, click Add Advice, and follow the APP prompts to complete the subsequent operations.
6. If the home page does not prompt "Devices to be added", you need to manually tap the top right "+" icon in the top right corner, click Add Advice, and follow the APP prompts to complete the subsequent operations.

Syncing with Input Source



Make sure the sync box is correctly connected to power, control box, input and output sources as instructed before synchronizing.

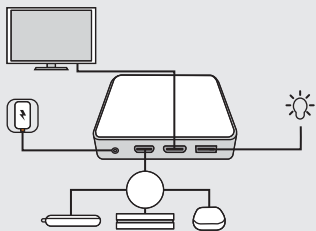

1. Connect sync box to devices and power as instructed.

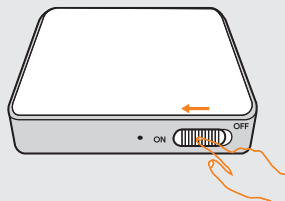

2. Slide ON / OFF switch to turn the sync box on.



3. Optionally, open App, tap  and then select to sync with screen-light strip.

Controlling with APP



To customize your controls, make sure that Sync mode is not selected. You can exit sync mode on APP or by pressing MODE button on control box.

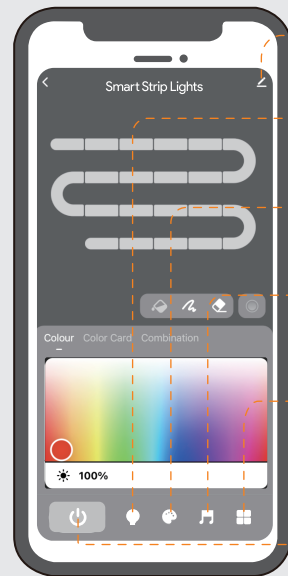

About

Information about the device or other settings.



Static Color Settings

Customize the color or brightness for the whole or section.



Dynamic Scene Settings

Select a preset scene (42 scenes available), edit or add a new scene.



Music Rhythm

Select the rhythm collected by the mic of light (6 local modes) or smart device (3 APP modes).



Plan

Schedule for the auto-off timer.

Sync Mode

Set the sync locations and start syncing.



Power ON / OFF

Tap to turn ON / OFF the strip light.

Countdown

Schedule for the auto-on timer.

Tip:

1. If the HDMI box occurs in the following circumstances (restart/accidental toggling switch/accidental power failure), the system recovery time is about 15s. During this period, please do not operate the device again.
2. Keeping the device in the standby state, to ensure normal functions and stable working of device links.
3. In the Sync function in the APP, the numerical value can be adjusted according to your needs, such as:

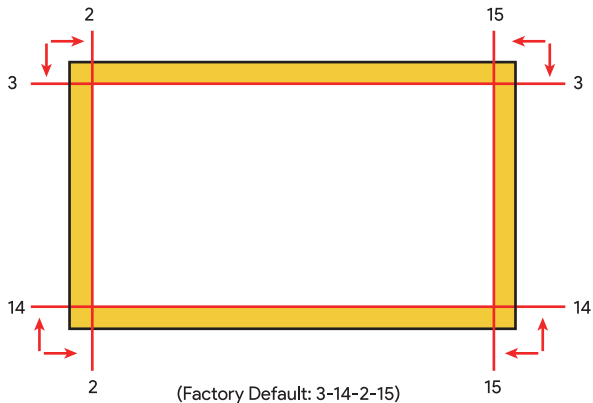

Troubleshooting

1. Cannot connect to Bluetooth.

Ensure Bluetooth on your smartphone has been turned on.

Your smartphone may be incompatible with the Smart Life app. Try using a different smartphone then reconnect.

Power the Strip Light and your smartphone Bluetooth off then on, then try again.

Ensure that your smartphone is within 1m/3.28ft of the Strip Light when connecting.

Clear any obstructions that are between the Strip Light and your smartphone.

2. The Strip Light does not display the full selected color/Some LED beads do not light up.

Please contact the support team for rapid product replacement.

3. Cannot sync the Strip Light to the beat of my music.

- Move the control box closer to the music source.
- Clean the mic on the control box then try again.

4. Cannot connect to Wi-Fi.

- Do not skip the Wi-Fi connecting steps in the app.
- 5GHz network is not supported. Please set the router to 2.4GHz and then reset it.
- Connect your phone to Wi-Fi and check whether the network works well.
- Make sure you have entered the correct Wi-Fi name and password.
- Change your Wi-Fi password to a brief one. 8 numbers and letters are suggested.
- Connect hotspot in your phone to the Strip Light and check whether the router works with the Strip Light.

5. Cannot connect to Alexa.

- Pull out every connective part of the Strip Light and firmly re-connect them.
- Re-connect your phone to Wi-Fi.
- Plug out the adapter port and re-plug it in.

FCC Radiation Exposure Statement

This device complies with Part 15 of the FCC Rules. Operation is subject to the following two conditions: (1) this device may not cause harmful interference, and (2) this device must accept any interference received, including interference that may cause undesired operation. Changes or modifications not expressly approved by the party responsible for compliance could void the user's authority to operate the equipment.

NOTE: This equipment has been tested and found to comply with the limits for a Class B digital device, pursuant to Part 15 of the FCC Rules. These limits are designed to provide reasonable protection against harmful interference in a residential installation. This equipment generates, uses and can radiate radio frequency energy and, if not installed and used in accordance with the instructions, may cause harmful interference to radio communications. However, there is no guarantee that interference will not occur in a particular installation. If this equipment does cause harmful interference to radio or television reception, which can be determined by turning the equipment off and on, the user is encouraged to try to correct the interference by one or more of the following measures:

- Reorient or relocate the receiving antenna.
- Increase the separation between the equipment and receiver,
- Connect the equipment into an outlet on a circuit different from that to which the receiver is connected
- Consult the dealer or an experienced radio/TV technician for help.

NOTE: This device and its antenna(s) must not be co-located or operation in conjunction with any other antenna or transmitter

FCC Radiation Exposure Statement: This equipment complies with FCC radiation exposure limits set forth for an uncontrolled environment. This equipment should be installed and operated with a minimum distance of 20 cm between the radiator and your body.

Manufacturer: Shenzhen Linklite Smart Lighting Co., Ltd.
Address: 4th floor, 3 building, Yangbei industrial park 1st phase, Huangtian,
Hangcheng street, Bao'an distr, Shenzhen, Guangdong Province, China



Made in China