

434MHz SoC Wireless transceiver module

Product overview

The RFM380F64 is an integrated ARM Cortex-M0 32-bit CPU kernel with an ultra-low-power RF transceiver, low-power consumption, high sensitivity, remote communication, and a highly cost-effective SoC RF transceiver module.

Integrated with rich peripherals, support standard UART, I2C and SPI interfaces, providing multiple general IO, support internal fast RC concussion, internal slow RC concussion and 32.768 kHz external crystal oscillator, support multiple package formats and codec, up to 64-byte Tx / Rx FIFO, feature-rich RF GPIO, multiple low-power operating modes and fast start mechanism, high precision RSSI, manual fast frequency hopping and multi-channel input 12-bit high-speed ADC.

The product is divided into 434MHz working frequencies, supporting a data rate range of 0.5–300kbps



RFM380F32

product features

- Super anti-interference ability, suitable for the use of complex interference environment scenarios
- Receive sensitivity: -120 dBm @ 434MHz, 0.6bps, GFSK
- Operating frequency: 434MHz
- Power supply voltage input range: 1.8V–3.6V
- Emission current: 74mA @ +20dBm, 434MHz
- Receive current: 12mA @434MHz, FSK
- Deep sleep current: 2.5uA
- Operating rate: 0.5–300 kbps

applied range

- Automatic meter reading
- Furniture Security and Building automation
- Wireless sensing nodes and industrial monitoring
- ISM frequency band data communication

Table 1, the foot-bit definition of the RFM380F32

foot	name	describe	Configuration function
1	P36	MCU and so on IO	UART1_RXD、TIM6_CHA、UART0_RXD、PCA_CH4、TIM5_CHA、spi_mosi、i2c_scl、AIN6/VC6/AVREF
2	P35	MCU and so on IO	UART0_TXD, TIM0_GATE、TIM4_CHB、SPI_MISO, I2C_SDA, AIN5/VC5, UART1_TXD
3	RESET	Hard reset pin	-----
4	P33	MCU and so on IO	UART2_RXD、pca_ch1、tim5_chb、PCA_ECI、UART1_RXD、XTL_OUT、TIM1_TOGN、AIN3/VC3
5	GPIO3	The GPIO3 of the RF	CLKO, DOUT/DIN, INT2,DCLK (TX/RX)
6	VCC	Positive power supply	-----
7	GND	earth wire	-----
8	RFOUT	RF output	-----
9	P01	MCU and so on IO	UART0_RXD,I2C_SDA, UART1_TXD, TIM0_TOG, TIM5_CHB, SPI_SCK, TIM2_EXT, AIN7/VC7,XTHI
10	P02	MCU and so on IO	uart0_txd, i2c_scl, uart1_rxd, tim0_togn, tim6_cha, spi_cs, tim2_gate, ain8, extho
11	P25	MCU and so on IO	SPI_SCK、pca_ch0、tim5_cha、LVD_OUT、UART2_RXD、I2C_SDA、TIM1_GATE、LVDIN3/VC1
12	P26	MCU and so on IO	SPI_MOSI, TIM4_CHA, TIM5_CHB, PCA_CH2, UART2_TXD, I2C_SCL, TIM1_EXT, AIN
13	SWDIO	SW shakedown test IO	-----
14	SWCLK	TheSW debugging clock	-----
15	GPIO1	The GPIO1 of the RF	DOUT/DIN, INT1,INT2,DCLK (TX/RX),RF_SWT

remarks:

- 1 RFM380F32 chip 32nd foot SCLK and chip 27th foot has been external connected
- 2 RFM380F32 chip 33rd foot SDA and the chip 26th foot are external connected
- 3 RFM380F32 chip 34th foot CSB and the chip 23th foot are external connected
- 4 RFM380F32 chip 35th foot FCSB and chip 9th foot has been external

Electrical parameters

Test conditions, power supply 3.3V, temperature 25°C

Table 2, a list of electrical parameters

parameter	symbol	status	least value	representative value	crest value	unit
service frequency		RFM380F32-433S2		434		MHZ
mode	MOD				FSK	
receiving sensitivity		434MHz1 Kbps		-120		DBM
data rate	DR		0.5	2.4	300	Kbps
Receive bandwidth	BW		50		330	KHZ
working voltage	VDD		1.8	3.3	3.6	V
Receive working current	IRX	434MHZ		9	10	mA
Launch working current	ITX	434MHZ +20dbm		70	80	mA
Sleep current	ISleep				1	uA
image rejection	IMR			33		dB
image rejection	Top		-40		+80	°C

Module outline dimension drawing

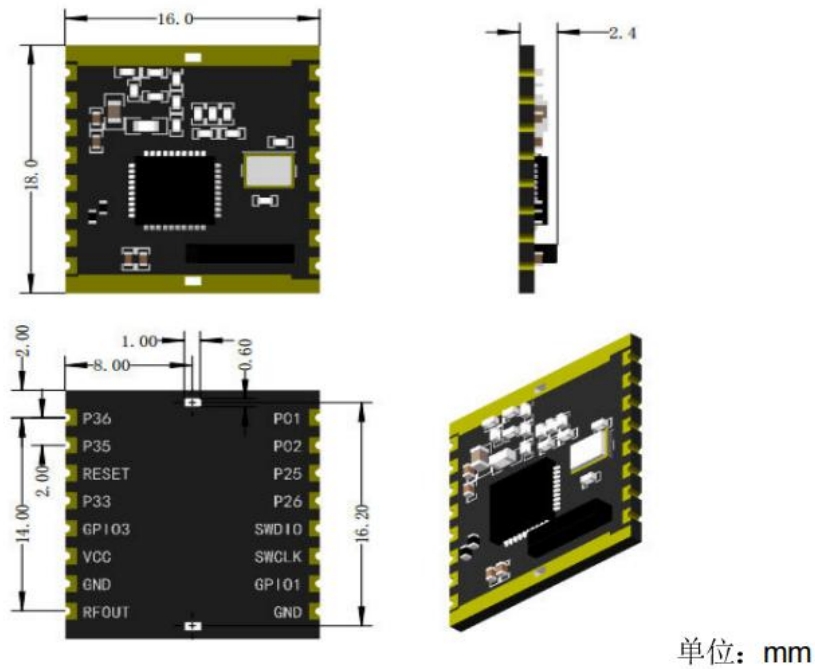

Figure 2, the module size diagram

<p>HOPEMICROELECTRONICS CO.,LTD Add: 2/F, Building 3, Pingshan Private Enterprise science and Technology Park, Xili Town, Nanshan District, Tel: 86-755-82973805 Fax: 86-755-82973550 Email: sales@hoperf.com Website: http://www.hoperf.com http://www.hoperf.cn</p>	<p>This document may contain preliminary information and is subject to change by Hope Microelectronics without notice. Hope Microelectronics assumes no responsibility or liability for any use of the information contained herein. Nothing in this document shall operate as an express or implied license or indemnity under the intellectual property rights of Hope Microelectronics or third parties.</p> <p>The products described in this document are not intended for use in implantation or other direct life support applications where malfunction may result in the direct physical harm or injury to persons. NO WARRANTIES OF ANY KIND, INCLUDING, BUT NOT LIMITED TO, THE IMPLIED WARRANTIES OF MERCHANTABILITY OR FITNESS FOR A PARTICULAR PURPOSE, ARE OFFERED IN THIS DOCUMENT.</p> <p>©2006, HOPEMICROELECTRONICS CO., LTD. All rights reserved.</p>
--	---

FCC Statement

FCC standards: FCC CFR Title 47 Part 15 Subpart C Section 15.231

Trace antenna with antenna gain 3.555dBi

This device complies with part 15 of the FCC Rules. Operation is subject to the following two conditions:

(1) This device may not cause harmful interference, and (2) this device must accept any interference received, including interference that may cause undesired operation.

Any Changes or modifications not expressly approved by the party responsible for compliance could void the user's authority to operate the equipment.

Note: This equipment has been tested and found to comply with the limits for a Class B digital device, pursuant to part 15 of the FCC Rules. These limits are designed to provide reasonable protection against harmful interference in a residential installation. This equipment generates, uses and can radiate radio frequency energy and, if not installed and used in accordance with the instructions, may cause harmful interference to radio communications. However, there is no guarantee that interference will not occur in a particular installation. If this equipment does cause harmful interference to radio or television reception, which can be determined by turning the equipment off and on, the user is encouraged to try to correct the interference by one or more of the following measures:

- Reorient or relocate the receiving antenna.
- Increase the separation between the equipment and receiver.
- Connect the equipment into an outlet on a circuit different from that to which the receiver is connected.
- Consult the dealer or an experienced radio/TV technician for help.

FCC Radiation Exposure Statement

This modular complies with FCC RF radiation exposure limits set forth for an uncontrolled environment.

This transmitter must not be co-located or operating in conjunction with any other antenna or transmitter.

If the FCC identification number is not visible when the module is installed inside another device, then the outside of the device into which the module is installed must also display a label referring to the enclosed module. This exterior label can use wording such as the following: "Contains Transmitter Module FCC ID: 2ASEORFM380F32 Or Contains FCC ID: 2ASEORFM380F32"

When the module is installed inside another device, the user manual of the host must contain below warning statements;

1. This device complies with Part 15 of the FCC Rules. Operation is subject to the following two conditions:

(1) This device may not cause harmful interference.

(2) This device must accept any interference received, including interference that may cause undesired operation.

Note: This equipment has been tested and found to comply with the limits for a Class B digital device, pursuant to part 15 of the FCC Rules. These limits are designed to provide reasonable protection against harmful interference in a residential installation. This equipment generates, uses and can radiate radio frequency energy and, if not installed and used in accordance with the instructions, may cause harmful interference to radio communications.

However, there is no guarantee that interference will not occur in a particular installation. If this equipment does cause harmful interference to radio or television reception, which can be determined by turning the equipment off and on, the user is encouraged to try to correct the interference by one or more of the following measures:

- Reorient or relocate the receiving antenna.
- Increase the separation between the equipment and receiver.

–Connect the equipment into an outlet on a circuit different from that to which the receiver is connected.

–Consult the dealer or an experienced radio/TV technician for help.

2. Changes or modifications not expressly approved by the party responsible for compliance could void the user's authority to operate the equipment.

The devices must be installed and used in strict accordance with the manufacturer's instructions as described in the user documentation that comes with the product.

Any company of the host device which install this modular with modular approval should perform the test of radiated & conducted emission and spurious emission,etc. according to FCC part 15C : 15.231 and 15.209 & 15.207 ,15B Class B requirement, Only if the test result comply with FCC part 15C : 15.231 and 15.209 & 15.207 ,15B Class B requirement, then the host can be sold legally.

Directional spring antenna specification

Below is antenna specification

You can see antenna size from below specification

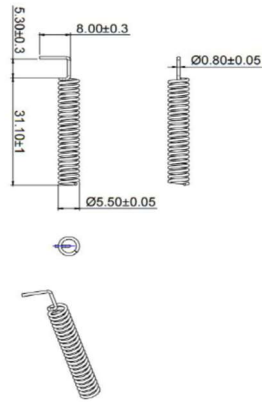

And PCB Pad size for spring antenna just follow the below chart.

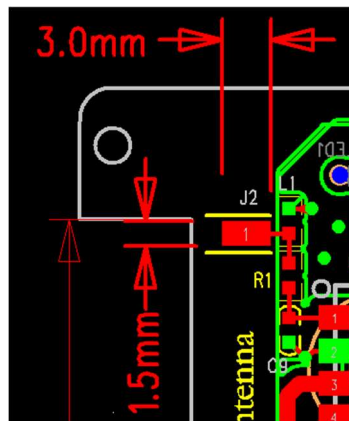

Spring antenna location on PCB are J2, and the Empty Area except spring antenna should be see just follow the below two charts.

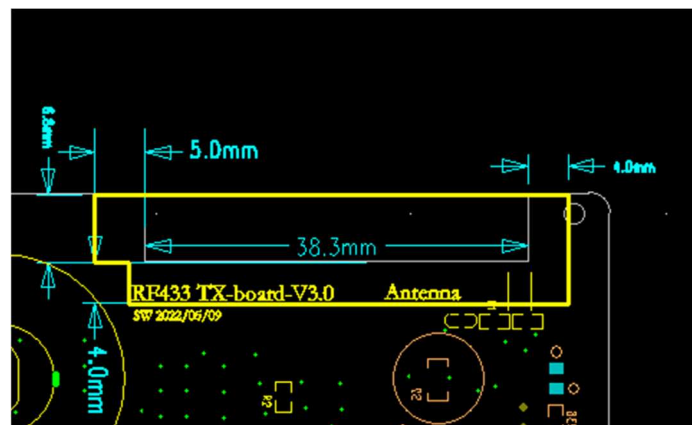

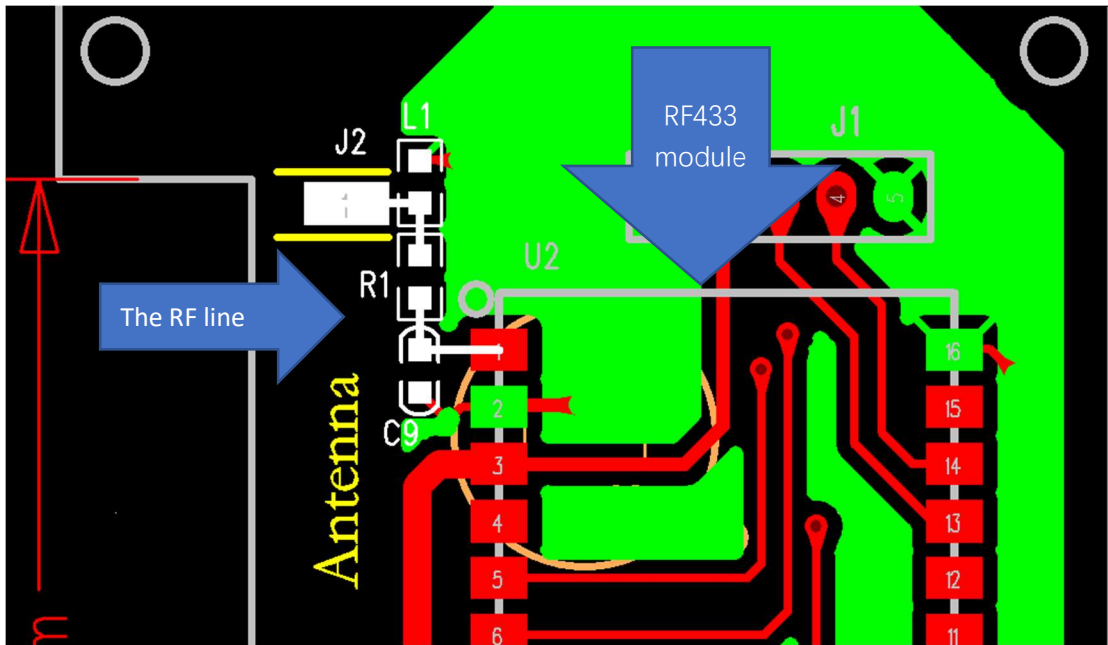
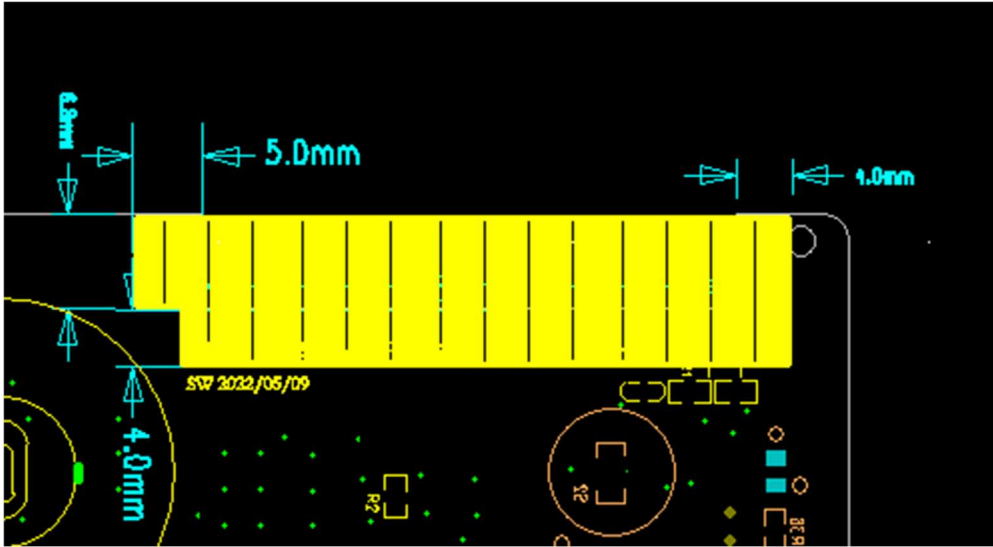

- L1—15nH, 0603;
- R1—0Ω, 0603;
- C9, no use