



FCC SAR TEST REPORT

Report No.: STS2108195H01

Issued for

Shandong Senter Electronic Co., Ltd.

No.18 Liuyishan Rd, New & Hi-Tech Area, Zibo, Shandong,
China

Product Name:	Industrial PDA
Brand Name:	SENER
Model Name:	S917 V9
Series Model:	N/A
FCC ID:	2ASDX-S917V9
Test Standard:	ANSI/IEEE Std. C95.1
	FCC 47 CFR Part 2 (2.1093)
	IEEE 1528: 2013
Max. Report SAR (1g):	Body: 1.225 W/kg

Any reproduction of this document must be done in full. No single part of this document may be reproduced without permission from STS, All Test Data Presented in this report is only applicable to presented Test sample.

ShenZhen STS Test Services Co.,Ltd.

A 1/F, Building B, Zhuoke Science Park, No.190 Chongqing Road, HepingShequ, Fuyong Sub-District, Bao'an District, Shenzhen, Guang Dong, China

TEL: +86-755 3688 6288 FAX: +86-755 3688 6277 E-mail:sts@ststest.com

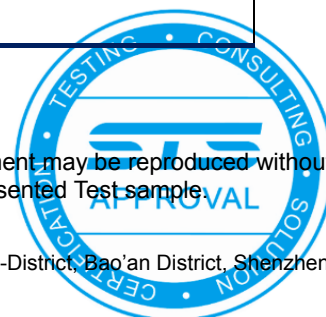



Test Report Certification

Applicant's name : Shandong Senter Electronic Co., Ltd.
 Address : No.18 Liuyishan Rd, New & Hi-Tech Area, Zibo, Shandong, China
Manufacturer's Name : Shandong Senter Electronic Co., Ltd.
 Address : No.18 Liuyishan Rd, New & Hi-Tech Area, Zibo, Shandong, China

Product description

Product name : Industrial PDA
 Brand name : SENTER
 Model name : S917 V9
 Series Model..... : N/A

Standards : ANSI/IEEE Std. C95.1-1992
 FCC 47 CFR Part 2 (2.1093)
 IEEE 1528: 2013

The device was tested by Shenzhen STS Test Services Co., Ltd. in accordance with the measurement methods and procedures specified in KDB 865664 The test results in this report apply only to the tested sample of the stated device/equipment. Other similar device/equipment will not necessarily produce the same results due to production tolerance and measurement uncertainties.

Date of Test :
 Date (s) of performance of tests : 12 Sept. 2021 ~ 24 Sept. 2021
 Date of Issue..... : 28 Sept. 2021
 Test Result..... : **Pass**

Testing Engineer : Shi fan-long
 (Shifan. Long)

Technical Manager : Sean she
 (Sean she)

Authorized Signatory : Vita Li
 (Vita Li)





Table of Contents

1. General Information	5
1.1 EUT Description	5
1.2 Test Environment	7
1.3 Test Factory	7
2. Test Standards and Limits	8
3. SAR Measurement System	9
3.1 Definition of Specific Absorption Rate (SAR)	9
3.2 SAR System	9
4. Tissue Simulating Liquids	12
4.1 Simulating Liquids Parameter Check	12
5. SAR System Validation	15
5.1 Validation System	15
5.2 Validation Result	15
6. SAR Evaluation Procedures	16
7. EUT Antenna Location Sketch	17
7.1 SAR test exclusion consider table	18
8. EUT Test Position	21
8.1 Define Two Imaginary Lines on the Handset	21
8.2 Hotspot mode exposure position condition	22
9. Uncertainty	23
9.1 Measurement Uncertainty	23
9.2 System validation Uncertainty	24
10. Conducted Power Measurement	25
10.1 Test Result	25
11. EUT and Test Setup Photo	37
11.1 EUT Photo	37
11.2 Setup Photo	40
12. SAR Result Summary	44
12.1 Body-worn and Hotspot SAR	44
12.2 Repeated SAR measurement	51
13. Equipment List	55
Appendix A. System Validation Plots	56
Appendix B. SAR Test Plots	64
Appendix C. Probe Calibration and Dipole Calibration Report	73

**Revision History**

Rev.	Issue Date	Report No.	Effect Page	Contents
00	28 Sept. 2021	STS2108195H01	ALL	Initial Issue





1. General Information

Environmental evaluation measurements of specific absorption rate (SAR) distributions in emulated human head and body tissues exposed to radio frequency (RF) radiation from wireless portable devices for compliance with the rules and regulations of the U.S. Federal Communications Commission (FCC).

1.1 EUT Description

Product Name	Industrial PDA		
Brand Name	SENER		
Model Name	S917 V9		
Series Model	N/A		
Model Difference	N/A		
Battery	Rated Voltage:3.8V ChargeLimit Voltage:4.35V Capacity: 10Ah		
Device Category	Portable		
Product stage	Production unit		
RF Exposure Environment	General Population / Uncontrolled		
IMEI	867400020316612/01 867400020316620/01		
Hardware Version	S866T-9863A-V1.0 210308-C		
Software Version	SENER_S917 V9_20210623_v1.0		
Frequency Range	GSM 850: 824 MHz ~ 849 MHz PCS1900: 1850 MHz ~ 1910 MHz WCDMA Band II: 1850MHz ~ 1910 MHz WCDMA Band V:824 MHz ~ 849 MHz WCDMA Band IV1710MHz ~1755 MHz LTE Band 2: 1850 MHz to 1900 MHz LTE Band 4: 1710 MHz to 1755 MHz LTE Band 5: 820 MHz to 850 MHz WLAN802.11b/g/n20: 2412 MHz ~ 2462 MHz WLAN802.11n40: 2422 MHz ~ 2452 MHz Bluetooth: 2402 MHz to 2480 MHz GPS: 1575.42MHz FM: 87.5 MHz to 108 MHz		
Max. Reported SAR(1g): (Limit:1.6W/kg)	Band	Mode	Body Worn and Hotspot(W/kg)
	PCB	GSM 850	1.191
	PCB	GSM 1900	1.225
	PCB	WCDMA Band II	0.926
	PCB	WCDMA Band V	1.082
	PCB	WCDMA Band IV	1.174
	PCB	LTE band 2	0.950
	PCB	LTE band 4	0.921
	PCB	LTE band 5	1.178
	DTS	2.4G WLAN	0.330
	DSS	Bluetooth ¹	0.053
1-g Sum SAR			1.555
FCC Equipment Class	Licensed Portable Transmitter Held to Ear (PCB) Part 15 Spread Spectrum Transmitter (DSS) Digital Transmission System (DTS)		



Operating Mode:	GSM: GSM Voice; GPRS/EGPRS Class 12 WCDMA: RMC, HSDPA, HSUPA Release 6 LTE: QPSK, 16QAM WLAN: 802.11 b/g/n20/n40 Bluetooth: 5.1(GFSK + π /4DQPSK+8DPSK) BLE:GFSK
Antenna Specification:	GSM/WCDMA/LTE: PIFA Antenna Bluetooth: PIFA Antenna WLAN: PIFA Antenna FM: Earphone Antenna
SIM Card	Support dual-SIM, dual standby, the multiple SIM card with two lines cannot transmitting at the same time
Hotspot Mode	Support
DTM Mode	Not Support
Note:	<ol style="list-style-type: none">1. Bluetooth SAR was estimated2. The dual SIM card mobile has 2 SIM slots and supports dual SIM dual standby. The WWAN radio transmission will be enabled by either one SIM at a time (Single active)3. After pre-scan two SIM cards power, we found test result of the SIM1 was the worse, so we chose SIM1 card to perform all tests.4. The EUT battery must be fully charged and checked periodically during the test to ascertain uniform power





1.2 Test Environment

Ambient conditions in the SAR laboratory:

Items	Required
Temperature (°C)	18-25
Humidity (%RH)	30-70

1.3 Test Factory

ShenZhen STS Test Services Co.,Ltd.

A 1/F, Building B, Zhuoke Science Park, No.190 Chongqing Road, HepingShequ, Fuyong Sub-District, Bao'an District, Shenzhen, Guang Dong, China

FCC test Firm Registration No.: 625569

IC Registration No.: 12108A

A2LA Certificate No.: 4338.01





2. Test Standards and Limits

No.	Identity	Document Title
1	47 CFR Part 2	Frequency Allocations and Radio Treaty Matters; General Rules and Regulations
2	ANSI/IEEE Std. C95.1-1992	IEEE Standard for Safety Levels with Respect to Human Exposure to Radio Frequency Electromagnetic Fields, 3 kHz to 300 GHz
3	IEEE Std. 1528-2013	Recommended Practice for Determining the Peak Spatial-Average Specific Absorption Rate (SAR) in the Human Head from Wireless Communications Devices: Measurement Techniques
4	FCC KDB 447498 D01 v06	Mobile and Portable Device RF Exposure Procedures and Equipment Authorization Policies
5	FCC KDB 865664 D01 v01r04	SAR Measurement 100 MHz to 6 GHz
6	FCC KDB 865664 D02 v01r02	RF Exposure Reporting
7	FCC KDB 941225 D01 v03r01	SAR Measurement Procedures for 3G Devices
8	FCC KDB 941225 D05 v02r05	SAR for LTE Devices
9	FCC KDB 941225 D06 v02r01	Hotspot Mode SAR
10	FCC KDB 648474 D04 v01r03	SAR Evaluation Considerations for Wireless Handsets
11	FCC KDB 248227 D01 Wi-Fi SAR v02r02	SAR Considerations for 802.11 Devices

(A). Limits for Occupational/Controlled Exposure (W/kg)

Whole-Body	Partial-Body	Hands, Wrists, Feet and Ankles
0.4	8.0	20.0

(B). Limits for General Population/Uncontrolled Exposure (W/kg)

Whole-Body	Partial-Body	Hands, Wrists, Feet and Ankles
0.08	1.6	4.0

NOTE: Whole-Body SAR is averaged over the entire body, partial-body SAR is averaged over any 1 gram of tissue defined as a tissue volume in the shape of a cube. SAR for hands, wrists, feet and ankles is averaged over any 10 grams of tissue defined as a tissue volume in the shape of a cube.

Population/Uncontrolled Environments:

Are defined as locations where there is the exposure of individuals who have no knowledge or control of their exposure.

Occupational/Controlled Environments:

Are defined as locations where there is exposure that may be incurred by people who are aware of the potential for exposure, (i.e. as a result of employment or occupation).

<p>NOTE</p> <p>GENERAL POPULATION/UNCONTROLLED EXPOSURE</p> <p>PARTIAL BODY LIMIT</p> <p>1.6 W/kg</p>

3. SAR Measurement System

3.1 Definition of Specific Absorption Rate (SAR)

SAR is related to the rate at which energy is absorbed per unit mass in an object exposed to a radio field. The SAR distribution in a biological body is complicated and is usually carried out by experimental techniques or numerical modeling. The standard recommends limits for two tiers of groups, occupational/controlled and general population/uncontrolled, based on a person's awareness and ability to exercise control over his or her exposure. In general, occupational/controlled exposure limits are higher than the limits for general population/uncontrolled.

The SAR definition is the time derivative (rate) of the incremental energy (dW) absorbed by (dissipated in) an incremental mass (dm) contained in a volume element (dv) of a given density (ρ). The equation description is as below:

$$SAR = \frac{d}{dt} \left(\frac{dW}{dm} \right) = \frac{d}{dt} \left(\frac{dW}{\rho dv} \right)$$

SAR is expressed in units of Watts per kilogram (W/kg) SAR measurement can be related to the electrical field in the tissue by

$$SAR = \frac{\sigma E^2}{\rho}$$

Where: σ is the conductivity of the tissue,
ρ is the mass density of the tissue and E is the RMS electrical field strength.

3.2 SAR System

MVG SAR System Diagram:

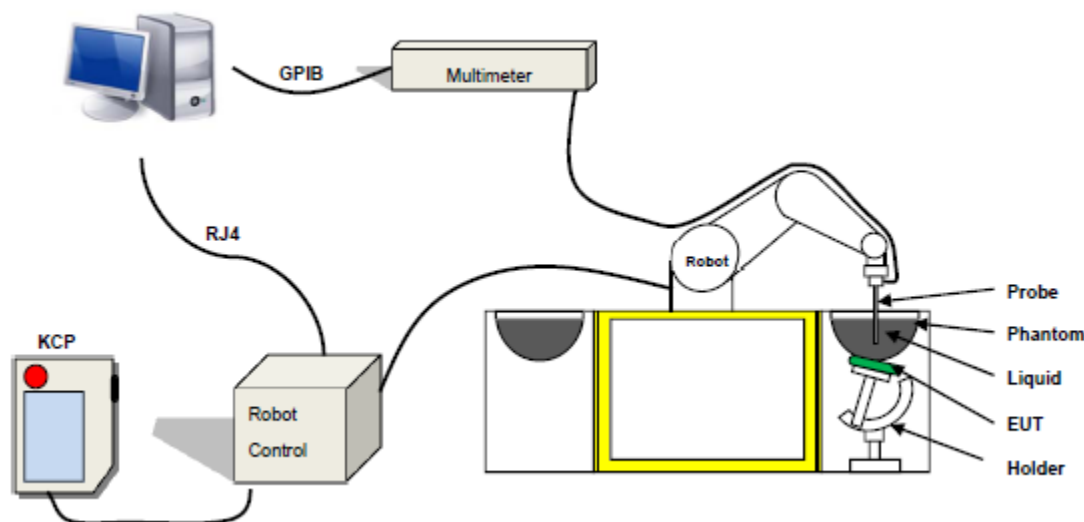

COMOSAR is a system that is able to determine the SAR distribution inside a phantom of human being according to different standards. The COMOSAR system consists of the following items:

- Main computer to control all the system
- 6 axis robot
- Data acquisition system
- Miniature E-field probe
- Phone holder
- Head simulating tissue

The following figure shows the system.



The EUT under test operating at the maximum power level is placed in the phone holder, under the phantom, which is filled with head simulating liquid. The E-Field probe measures the electric field inside the phantom. The Open SAR software computes the results to give a SAR value in a 1g or 10g mass.

3.2.1 Probe

For the measurements the Specific Dosimetric E-Field Probe SN 07/21 EPGO352 with following specifications is used

- Probe Length: 330 mm
- Length of Individual Dipoles: 2 mm
- Maximum external diameter: 8 mm
- Probe Tip External Diameter: 2.5 mm
- Distance between dipole/probe extremity: 1 mm
- Dynamic range: 0.01-100 W/kg
- Probe linearity: 3%
- Axial Isotropy: < 0.10 dB
- Spherical Isotropy: < 0.10 dB
- Calibration range: 450 MHz to 6 GHz for head & body simulating liquid.
- Angle between probe axis (evaluation axis) and surface normal line: less than 30°



Figure 1-MVG COMOSAR Dosimetric E field Dipole

3.2.2 Phantom

For the measurements the Specific Anthropomorphic Mannequin (SAM) defined by the IEEE SCC-34/SC2 group is used. The phantom is a polyurethane shell integrated in a wooden table. The thickness of the phantom amounts to 2mm +/- 0.2mm. It enables the dosimetric evaluation of left and right phone usage and includes an additional flat phantom part for the simplified performance check. The phantom set-up includes a cover, which prevents the evaporation of the liquid.

SN 32/14 SAM115



SN 32/14 SAM116



3.2.3 Device Holder

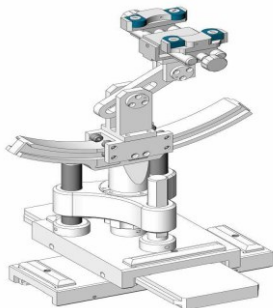

The SAR in the phantom is approximately inversely proportional to the square of the distance between the source and the liquid surface. For a source at 5 mm distance, a positioning uncertainty of ± 0.5 mm would produce a SAR uncertainty of ± 20 %. Accurate device positioning is therefore crucial for accurate and repeatable measurements. The positions in which the devices must be measured are defined by the standards.

4. Tissue Simulating Liquids



4. Tissue Simulating Liquids

4.1 Simulating Liquids Parameter Check

The head tissue dielectric parameters recommended by the IEEE SCC-34/SC-2 in P1528 have been incorporated in the following table. These head parameters are derived from planar layer models simulating the highest expected SAR for the dielectric properties and tissue thickness variations in a human head. Other head and body tissue parameters that have not been specified in P1528 are derived from the tissue dielectric parameters computed from the 4-Cole-Cole equations described in Reference [12] and extrapolated according to the head parameters specified in P1528.

Head Tissue

Frequency (MHz)	cellulose	DGBE	HEC	NaCl	Preventol	Sugar	X100	Water	Conductivity	Permittivity
	%	%	%	%	%	%	%	%	σ	ϵ_r
750	0.2	/	/	1.4	0.2	57.0	/	41.1	0.89	41.9
835	0.2	/	/	1.4	0.2	57.9	/	40.3	0.90	41.5
900	0.2	/	/	1.4	0.2	57.9	/	40.3	0.97	41.5
1800	/	44.5	/	0.3	/	/	30.45	55.2	1.4	40.0
1900	/	44.5	/	0.3	/	/	30.45	55.2	1.4	40.0
2000	/	44.5	/	0.3	/	/	/	55.2	1.4	40.0
2450	/	44.9	/	0.1	/	/	/	55.0	1.80	39.2
2600	/	45.0	/	0.1	/	/	/	54.9	1.96	39.0

Body Tissue

Frequency (MHz)	cellulose	DGBE	HEC	NaCl	Preventol	Sugar	X100	Water	Conductivity	Permittivity
	%	%	%	%	%	%	%	%	σ	ϵ_r
750	0.2	/	/	0.9	0.1	47.2	/	51.7	0.96	55.5
835	0.2	/	/	0.9	0.1	48.2	/	50.8	0.97	55.2
900	0.2	/	/	0.9	0.1	48.2	/	50.8	1.05	55.0
1800	/	29.4	/	0.4	/	/	30.45	70.2	1.52	53.3
1900	/	29.4	/	0.4	/	/	30.45	70.2	1.52	53.3
2000	/	29.4	/	0.4	/	/	/	70.2	1.52	53.3
2450	/	31.3	/	0.1	/	/	/	68.6	1.95	52.7
2600	/	31.7	/	0.1	/	/	/	68.2	2.16	52.3

Tissue dielectric parameters for head and body phantoms				
Frequency	ϵ_r		σ S/m	
	Head	Body	Head	Body
	300	45.3	58.2	0.87
450	43.5	56.7	0.87	0.94
900	41.5	55.0	0.97	1.05
1450	40.5	54.0	1.20	1.30
1800	40.0	53.3	1.40	1.52
2450	39.2	52.7	1.80	1.95
3000	38.5	52.0	2.40	2.73
5800	35.3	48.2	5.27	6.00



LIQUID MEASUREMENT RESULTS

Date	Ambient		Simulating Liquid		Parameters	Target	Measured	Deviation %	Limited %
	Temp. [°C]	Humidity %	Frequency	Temp. [°C]					
2012-09-12	23.5	55	824.2 MHz	23.3	Permittivity	41.50	41.99	1.18	±5
					Conductivity	0.89	0.89	0.00	±5
2012-09-12	23.5	55	826.4 MHz	23.3	Permittivity	41.50	41.82	0.77	±5
					Conductivity	0.89	0.90	1.12	±5
2012-09-12	23.5	55	829 MHz	23.3	Permittivity	41.50	41.93	1.04	±5
					Conductivity	0.89	0.91	2.25	±5
2012-09-12	23.5	55	835 MHz	23.3	Permittivity	41.50	41.64	0.34	±5
					Conductivity	0.90	0.92	2.22	±5
2012-09-12	23.5	55	836.5 MHz	23.3	Permittivity	41.50	40.67	-2.00	±5
					Conductivity	0.90	0.94	4.44	±5
2012-09-12	23.5	55	836.6 MHz	23.3	Permittivity	41.50	41.21	-0.70	±5
					Conductivity	0.90	0.89	-1.11	±5
2012-09-12	23.5	55	844 MHz	23.3	Permittivity	41.50	43.14	3.95	±5
					Conductivity	0.91	0.91	0.00	±5
2012-09-12	23.5	55	846.6 MHz	23.3	Permittivity	41.50	40.28	-2.94	±5
					Conductivity	0.91	0.93	2.20	±5
2012-09-12	23.5	55	848.8 MHz	23.3	Permittivity	41.50	40.70	-1.93	±5
					Conductivity	0.90	0.90	-0.19	±5
2012-09-12	23.5	55	900 MHz	23.3	Permittivity	41.50	43.14	3.95	±5
					Conductivity	0.91	0.89	-2.20	±5
2012-09-17	24.3	54	1720 MHz	24.1	Permittivity	40.11	40.79	1.70	±5
					Conductivity	1.35	1.37	1.48	±5
2012-09-17	24.3	54	1720.6 MHz	24.1	Permittivity	40.11	39.86	-0.62	±5
					Conductivity	1.35	1.32	-2.22	±5
2012-09-17	24.3	54	1732.5 MHz	24.1	Permittivity	40.10	39.75	-0.87	±5
					Conductivity	1.36	1.35	-0.74	±5
2012-09-17	24.3	54	1740 MHz	24.1	Permittivity	40.09	39.23	-2.15	±5
					Conductivity	1.37	1.36	-0.73	±5
2012-09-17	24.3	54	1745 MHz	24.1	Permittivity	40.08	39.98	-0.25	±5
					Conductivity	1.37	1.36	-0.73	±5
2012-09-17	24.3	54	1800 MHz	24.1	Permittivity	40.00	38.79	-3.03	±5
					Conductivity	1.40	1.38	-1.43	±5



2012-09-23	23.7	49	1850.2 MHz	23.5	Permittivity	40.00	39.97	-0.08	±5
					Conductivity	1.40	1.40	0.00	±5
2012-09-23	23.7	49	1852.4 MHz	23.5	Permittivity	40.00	38.92	-2.70	±5
					Conductivity	1.40	1.41	0.71	±5
2012-09-23	23.7	49	1860 MHz	23.5	Permittivity	40.00	39.05	-2.38	±5
					Conductivity	1.40	1.37	-2.14	±5
2012-09-23	23.7	49	1880 MHz	23.5	Permittivity	40.00	39.45	-1.37	±5
					Conductivity	1.40	1.40	0.00	±5
2012-09-23	23.7	49	1900 MHz	23.5	Permittivity	40.00	40.65	1.63	±5
					Conductivity	1.40	1.39	-0.71	±5
2012-09-23	23.7	49	1907.6 MHz	23.5	Permittivity	40.00	40.06	0.15	±5
					Conductivity	1.40	1.44	2.86	±5
2012-09-23	23.7	49	1909.8 MHz	23.5	Permittivity	40.00	39.99	-0.02	±5
					Conductivity	1.40	1.44	2.86	±5
2012-09-24	23.4	51	2437 MHz	23.2	Permittivity	39.22	37.93	-3.29	±5
					Conductivity	1.79	1.75	-2.23	±5
2012-09-24	23.4	51	2450 MHz	23.2	Permittivity	39.20	39.88	1.73	±5
					Conductivity	1.80	1.80	0.00	±5

5. SAR System Validation

5.1 Validation System

Each MVG system is equipped with one or more system validation kits. These units, together with the predefined measurement procedures within the MVG software, enable the user to conduct the system performance check and system validation. System kit includes a dipole, and dipole device holder.

The system check verifies that the system operates within its specifications. It's performed daily or before every SAR measurement. The system check uses normal SAR measurement in the flat section of the phantom with a matched dipole at a specified distance. The system validation setup is shown as below.

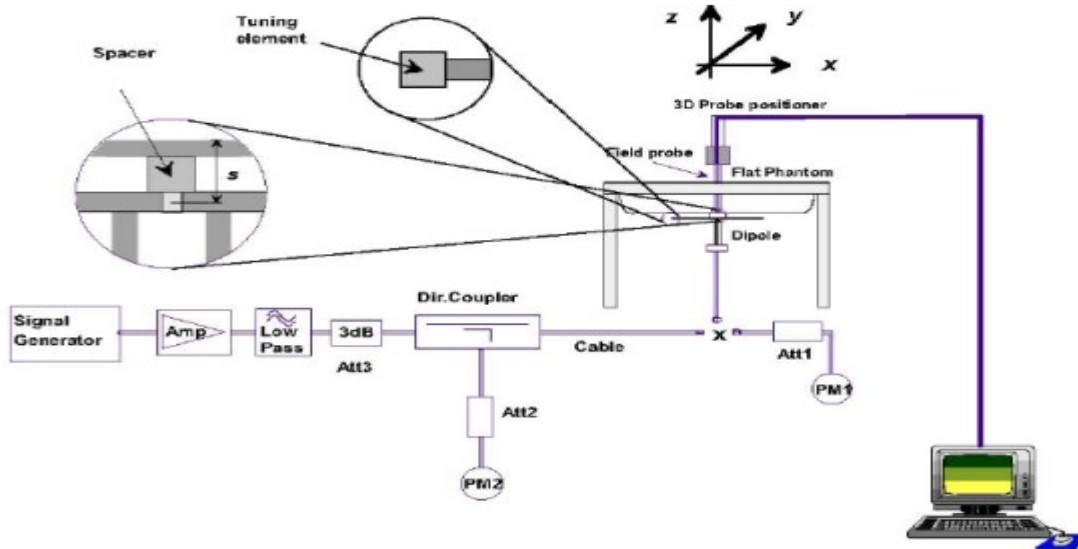

5.2 Validation Result

Comparing to the original SAR value provided by MVG, the validation data should be within its specification of 10 %.

Date	Freq.	Power	Tested Value	Normalized SAR	Target SAR	Tolerance	Limit
	(MHz)	(mW)	(W/Kg)	(W/kg)	1g(W/kg)	(%)	(%)
2012-09-12	835	100	0.974	9.74	9.56	1.88	10
2012-09-12	900	100	1.061	10.61	10.90	-2.66	10
2012-09-17	1800	100	3.801	38.01	38.40	-1.02	10
2012-09-23	1900	100	3.844	38.44	39.70	-3.17	10
2012-09-24	2450	100	5.363	53.63	52.40	2.35	10

Note:

1. The tolerance limit of System validation $\pm 10\%$.
2. The dipole input power (forward power) was 100 mW.
3. The results are normalized to 1 W input power.



6. SAR Evaluation Procedures

The procedure for assessing the average SAR value consists of the following steps:

The following steps are used for each test position

- Establish a call with the maximum output power with a base station simulator. The connection between the mobile and the base station simulator is established via air interface
- Measurement of the local E-field value at a fixed location. This value serves as a reference value for calculating a possible power drift.
- Measurement of the SAR distribution with a grid of 8 to 16mm * 8 to 16 mm and a constant distance to the inner surface of the phantom. Since the sensors cannot directly measure at the inner phantom surface, the values between the sensors and the inner phantom surface are extrapolated. With these values the area of the maximum SAR is calculated by an interpolation scheme.
- Around this point, a cube of 30 * 30 * 30 mm or 32 * 32 * 32 mm is assessed by measuring 5 or 8 * 5 or 8*4 or 5 mm. With these data, the peak spatial-average SAR value can be calculated.

➤ Area Scan& Zoom Scan

First Area Scan is used to locate the approximate location(s) of the local peak SAR value(s). The measurement grid within an Area Scan is defined by the grid extent, grid step size and grid offset. Next, in order to determine the EM field distribution in a three-dimensional spatial extension, Zoom Scan is required. The Zoom Scan is performed around the highest E-field value to determine the averaged SAR-distribution over 10 g. Area scan and zoom scan resolution setting follows KDB 865664 D01 quoted below.

When the 1-g SAR of the highest peak is within 2 dB of the SAR limit, additional zoom scans are required for other peaks within 2 dB of the highest peak that have not been included in any zoom scan to ensure there is no increase in SAR.

7. EUT Antenna Location Sketch

It is a Industrial PDA, support GSM/WCDMA/LTE/WLAN/BT mode.

Top side

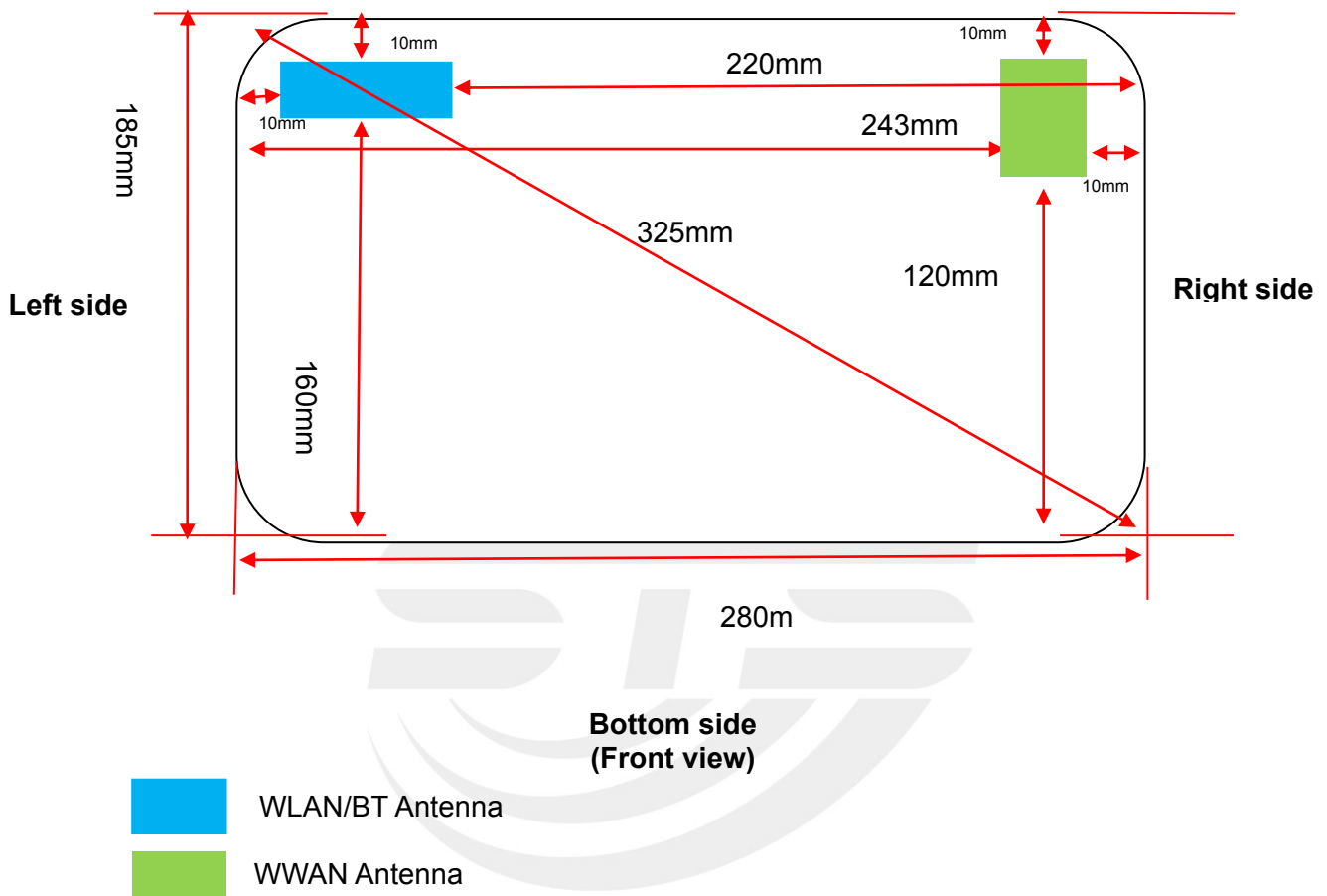

Note 1: The antenna information refer the manufacturer provide report, applicable only to the tested sample identified in the report.



7.1 SAR test exclusion consider table

The WWAN/WLAN/BT SAR evaluation of Maximum power (dBm) summing tolerance.

	Wireless Interface	GSM850	PCS1900	WCDMA 2	WCDMA 5	WCDMA 4
Exposure Position	Calculated Frequency	836.6	1880	1907.6	826.4	1712.6
	Maximum Turn-up power (dBm)	32.6	30.5	24.5	24.5	24
	Maximum rated power(mW)	1995.26	1000.00	251.19	199.53	328.85
	Separation distance (mm)	5	5	5	5	5
Back Side	exclusion threshold(mW)	16.40	10.94	10.86	16.50	11.46
	Testing required?	YES	YES	YES	YES	YES
	Separation distance (mm)	245	245	245	245	245
Left Edge	exclusion threshold(mW)	1251.58	2059.40	2058.60	1239.32	2064.62
	Testing required?	YES	NO	NO	NO	NO
	Separation distance (mm)	10	10	10	10	10
Right Edge	exclusion threshold(mW)	32.80	21.88	21.72	33.00	22.92
	Testing required?	YES	YES	YES	YES	YES
	Separation distance (mm)	10	10	10	10	10
Top Edge	exclusion threshold(mW)	32.80	21.88	21.72	33.00	22.92
	Testing required?	YES	YES	YES	YES	YES
	Separation distance (mm)	120	120	120	120	120
Bottom Edge	exclusion threshold(mW)	554.41	809.40	808.60	550.66	814.62
	Testing required?	YES	YES	NO	NO	NO
	Separation distance (mm)	120	120	120	120	120



Wireless Interface	LTE Band 2	LTE Band 4	LTE Band 5	BT	2.4G WLAN	
Exposure Position	Calculated Frequency	1860	1732.5	844	2402	2442
	Maximum Turn-up power (dBm)	23	23.5	24	1	13.5
	Maximum rated power(mW)	199.53	223.87	251.19	1.26	22.39
	Separation distance (mm)	5	5	5	5	5
Back Side	exclusion threshold(mW)	11.00	11.40	16.33	9.68	9.60
	Testing required?	YES	YES	YES	NO	YES
	Separation distance (mm)	245	245	245	10	10
Left Edge	exclusion threshold(mW)	2059.99	2063.96	1260.48	19.36	19.20
	Testing required?	NO	NO	NO	NO	YES
	Separation distance (mm)	10	10	10	220	220
Right Edge	exclusion threshold(mW)	22.00	22.79	32.66	1796.78	1795.99
	Testing required?	YES	YES	YES	NO	NO
	Separation distance (mm)	10	10	10	10	10
Top Edge	exclusion threshold(mW)	22.00	22.79	32.66	19.36	19.20
	Testing required?	YES	YES	YES	NO	YES
	Separation distance (mm)	120	120	120	160	160
Bottom Edge	exclusion threshold(mW)	809.99	813.96	557.14	1196.78	1195.99
	Testing required?	NO	NO	NO	NO	NO

**Note:**

1. maximum power is the source-based time-average power and represents the maximum RF output power among production units.
2. per KDB 447498 D01, for larger devices, the test separation distance of adjacent edge configuration is determined by the closest separation between the antenna and the user.
3. per KDB 447498 D01, standalone SAR test exclusion threshold is applied; if the distance of the antenna to the user is <25mm, 25mm is user to determine SAR exclusion threshold
4. per KDB 447498 D01, the 1-g and 10-g SAR test exclusion thresholds for 100 MHz to 6 GHz at test separation distance $\leq 50\text{mm}$ are determined by:
[(max.power of channel, including tune-up tolerance, mW)/(min. test separation distance, mm)]* $\sqrt{f(\text{GHz})} \leq 3.0$ for 1-g SAR and ≤ 7.5 for 10-g extremity SAR ,f(GHz) is the RF channel transmit frequency in GHz. Power and distance are rounded to the nearest mW and mm before calculation. The result is rounded to one decimal place for comparison
For <50mm distance, we just calculate mW of the exclusion threshold value(3.0)to do compare
5. per KDB 447498 D01, at 100 MHz to 6GHz and for test separation distances >50mm, the SAR test exclusion threshold is determined according to the following
 - a)[threshold at 50mm in step 1]+(test separation distance -50mm)*(f (MHz)/150)]mW, at 100 MHz to 1500 MHz
 - b) [threshold at 50mm in step1]+(test separation distance -50mm) *10]mW at > 1500MHz and $\leq 6\text{GHz}$
6. Per KDB 248227 D01, choose the highest output power channel to test SAR and determine further SAR exclusion 8.for each frequency band ,testing at higher data rates and higher order modulations is not required when the maximum average output power for each of each of these configurations is less than 1/4db higher than those measured at the lower data rate than 11b mode ,thus the SAR can be excluded.
7. Per KDB 616217 D04, SAR evaluation for the front surface of tablet display screens are generally not necessary.

8. EUT Test Position

This EUT was tested in Right Cheek, Right Titled, Left Cheek, Left Titled, Front Face and Rear Face.

8.1 Define Two Imaginary Lines on the Handset

(1) The vertical centerline passes through two points on the front side of the handset: the midpoint of the width w_t of the handset at the level of the acoustic output, and the midpoint of the width w_b of the handset.

(2) The horizontal line is perpendicular to the vertical centerline and passes through the center of the acoustic output. The horizontal line is also tangential to the face of the handset at point A.

(3) The two lines intersect at point A. Note that for many handsets, point A coincides with the center of the acoustic output; however, the acoustic output may be located elsewhere on the horizontal line. Also note that the vertical centerline is not necessarily to the front face of the handset, especially for clamshell handsets, handsets with flip covers, and other irregularly shaped handsets.

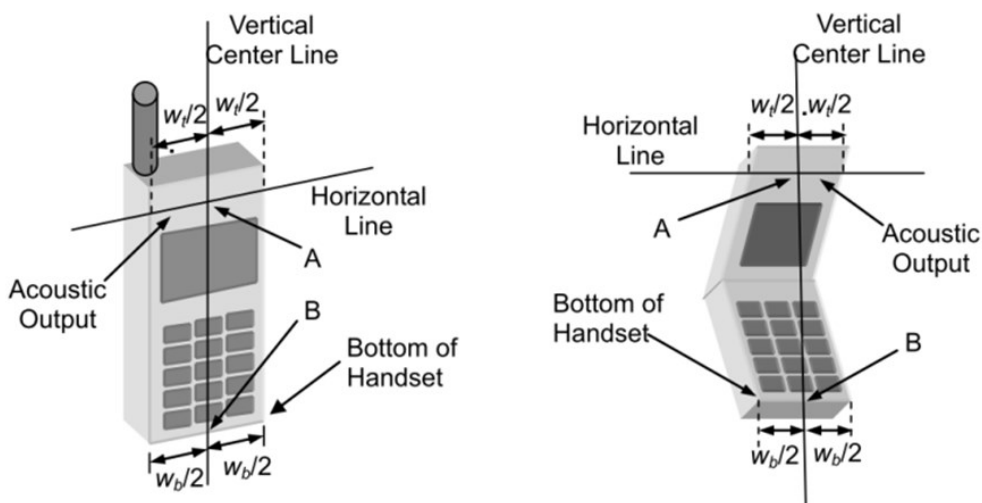

Cheek Position

1) To position the device with the vertical center line of the body of the device and the horizontal line crossing the center piece in a plane parallel to the sagittal plane of the phantom. While maintaining the device in this plane, align the vertical center line with the reference plane containing the ear and mouth reference point (M: Mouth, RE: Right Ear, and LE: Left Ear) and align the center of the ear piece with the line RE-LE.

2) To move the device towards the phantom with the ear piece aligned with the line LE-RE until the phone touched the ear. While maintaining the device in the reference plane and maintaining the phone contact with ear, move the bottom of the phone until any point on the front side is in contact with the cheek of the phantom or until contact with the ear is lost.

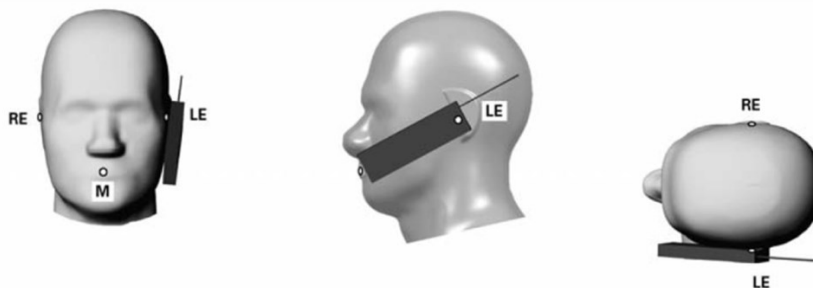

Title Position

- (1) To position the device in the “cheek” position described above.
- (2) While maintaining the device in the reference plane described above and pivoting against the ear, moves it outward away from the mouth by an angle of 15 degrees or until with the ear is lost.



Body-worn Position Conditions:

Body-worn accessory exposure is typically related to voice mode operations when handsets are carried in body-worn accessories. The body-worn accessory procedures in KDB Publication 447498 D01 should be used to test for body-worn accessory SAR compliance, without a headset connected to it. When the same wireless transmission configuration is used for testing body-worn accessory and hotspot mode SAR, respectively, in voice and data mode, SAR results for the most conservative *test separation distance* configuration may be used to support both SAR conditions. When the *reported SAR* for a body-worn accessory, measured without a headset connected to the handset, is > 1.2 W/kg, the highest *reported SAR* configuration for that wireless mode and frequency band should be repeated for the body-worn accessory with a headset attached to the handset.

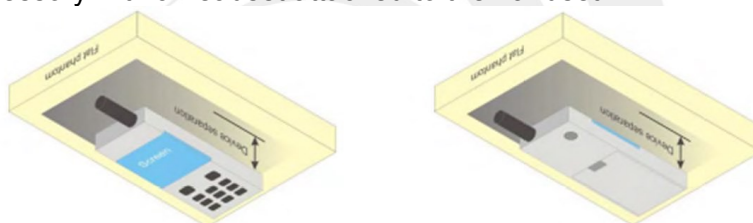

8.2 Hotspot mode exposure position condition

For handsets that support hotspot mode operations, with wireless router capabilities and various web browsing function, the relevant hand and body exposure condition are tested according to the hotspot SAR procedures in KDB 941225. A test separation distance of 10 mm is required between the phantom and all surface and edges with a transmitting antenna located within 25 mm from that surface or edge. When form factor of a handset is smaller than 9cm x 5cm, a test separation distance of 5mm (instead of 10mm) is required for testing hotspot mode. When the separate distance required for body-worn accessory testing is larger than or equal to that tested for hotspot mode, in the same wireless mode and for the same surface of the phone, the hotspot mode SAR data may be used to support body-worn accessory SAR compliance for that particular configuration (surface).

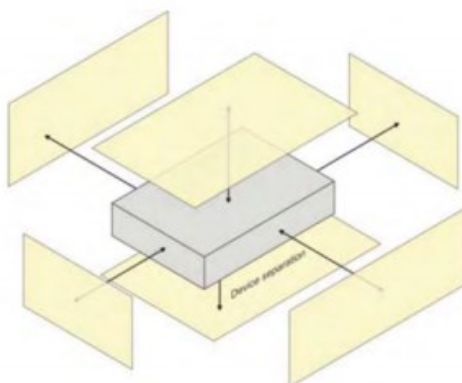



9. Uncertainty

9.1 Measurement Uncertainty

The following measurement uncertainty levels have been estimated for tests performed on the EUT as specified in IEEE 1528: 2013. This uncertainty represents an expanded uncertainty expressed at approximately the 95% confidence level using a coverage factor of k=2.

Uncertainty Component	Tol (+-%)	Prob. Dist.	Div.	Ci (1g)	Ci (10g)	1g Ui (+-%)	10g Ui (+-%)	vi
Measurement System								
Probe calibration	5.831	N	1	1	1	5.83	5.83	∞
Axial Isotropy	0.695	R	$\sqrt{3}$	$\sqrt{0.5}$	$\sqrt{0.5}$	0.28	0.28	∞
Hemispherical Isotropy	1.045	R	$\sqrt{3}$	$\sqrt{0.5}$	$\sqrt{0.5}$	0.43	0.43	∞
Boundary effect	1.0	R	$\sqrt{3}$	1	1	0.58	0.58	∞
Linearity	0.685	R	$\sqrt{3}$	1	1	0.40	0.40	∞
System detection limits	1.0	R	$\sqrt{3}$	1	1	0.58	0.58	∞
Modulation response	3.0	R	$\sqrt{3}$	1	1	1.73	1.73	∞
Readout Electronics	0.021	N	1	1	1	0.021	0.021	∞
Response Time	0	R	$\sqrt{3}$	1	1	0	0	∞
Integration Time	1.4	R	$\sqrt{3}$	1	1	0.81	0.81	∞
RF ambient conditions-Noise	3.0	R	$\sqrt{3}$	1	1	1.73	1.73	∞
RF ambient conditions-reflections	3.0	R	$\sqrt{3}$	1	1	1.73	1.73	∞
Probe positioner mechanical tolerance	1.4	R	$\sqrt{3}$	1	1	0.81	0.81	∞
Probe positioning with respect to phantom shell	1.4	R	$\sqrt{3}$	1	1	0.81	0.81	∞
Post-processing	2.3	R	$\sqrt{3}$	1	1	1.33	1.33	∞
Test sample Related								
Test sample positioning	2.6	N	1	1	1	2.6	2.6	∞
Device holder uncertainty	3	N	1	1	1	3	3	∞
SAR drift measurement	5	R	$\sqrt{3}$	1	1	2.89	2.89	∞
SAR scaling	5	R	$\sqrt{3}$	1	1	2.89	2.89	∞
Phantom and tissue parameters								
Phantom uncertainty (shape and thickness uncertainty)	4	R	$\sqrt{3}$	1	1	2.31	2.31	∞
Uncertainty in SAR correction for deviations in permittivity and conductivity	1.9	N	1	1	0.84	1.90	1.60	∞
Liquid conductivity (temperature uncertainty)	2.5	R	$\sqrt{3}$	0.78	0.71	1.13	1.02	∞
Liquid conductivity (measured)	4	N	1	0.78	0.71	3.12	2.84	M
Liquid permittivity (temperature uncertainty)	2.5	R	$\sqrt{3}$	0.23	0.26	0.33	0.38	∞
Liquid permittivity (measured)	5	N	1	0.23	0.26	1.15	1.30	M
Combined Standard Uncertainty		RSS				9.79	9.59	
Expanded Uncertainty (95% Confidence interval)		K=2				19.58	19.18	



9.2 System validation Uncertainty

Uncertainty Component	Tol (+-%)	Prob. Dist.	Div.	Ci (1g)	Ci (10g)	1g Ui (+-%)	10g Ui (+-%)	vi
Measurement System								
Probe calibration	5.831	N	1	1	1	5.83	5.83	∞
Axial Isotropy	0.695	R	$\sqrt{3}$	1	1	0.40	0.40	∞
Hemispherical Isotropy	1.045	R	$\sqrt{3}$	0	0	0.00	0.00	∞
Boundary effect	1.0	R	$\sqrt{3}$	1	1	0.58	0.58	∞
Linearity	0.685	R	$\sqrt{3}$	1	1	0.40	0.40	∞
System detection limits	1.0	R	$\sqrt{3}$	1	1	0.58	0.58	∞
Modulation response	3.0	R	$\sqrt{3}$	0	0	0.00	0.00	∞
Readout Electronics	0.021	N	1	1	1	0.021	0.021	∞
Response Time	0.0	R	$\sqrt{3}$	0	0	0.00	0.00	∞
Integration Time	1.4	R	$\sqrt{3}$	0	0	0.00	0.00	∞
RF ambient conditions-Noise	3.0	R	$\sqrt{3}$	1	1	1.73	1.73	∞
RF ambient conditions-reflections	3.0	R	$\sqrt{3}$	1	1	1.73	1.73	∞
Probe positioner mechanical tolerance	1.4	R	$\sqrt{3}$	1	1	0.81	0.81	∞
Probe positioning with respect to phantom shell	1.4	R	$\sqrt{3}$	1	1	0.81	0.81	∞
Post-Processing	2.3	R	$\sqrt{3}$	1	1	1.33	1.33	∞
System validation source								
Deviation of experimental dipole from numerical dipole	5.0	N	1	1	1	5.00	5.00	∞
Input power and SAR drift measurement	5.0	R	$\sqrt{3}$	1	1	2.89	2.89	∞
Other source contribution Uncertainty	2.0	R	$\sqrt{3}$	1	1	1.15	1.15	∞
Phantom and set-up								
Phantom uncertainty (shape and thickness uncertainty)	4.0	R	$\sqrt{3}$	1	1	2.31	2.31	∞
Uncertainty in SAR correction for deviations in permittivity and conductivity	1.9	N	1	1	0.84	1.90	1.60	∞
Liquid conductivity (temperature uncertainty)	2.5	R	$\sqrt{3}$	0.78	0.71	1.13	1.02	∞
Liquid conductivity (measured)	4	N	1	0.78	0.71	3.12	2.84	M
Liquid permittivity (temperature uncertainty)	2.5	R	$\sqrt{3}$	0.23	0.26	0.33	0.38	∞
Liquid permittivity (measured)	5	N	1	0.23	0.26	1.15	1.30	M
Combined Standard Uncertainty		RSS				9.718	9.517	
Expanded Uncertainty (95% Confidence interval)		K=2				19.44	19.04	



10. Conducted Power Measurement

10.1 Test Result

Burst Average Power (dBm)						
Band	GSM 850			PCS 1900		
Channel	128	190	251	512	661	810
Frequency (MHz)	824.2	836.6	848.8	1850.2	1880	1909.8
GSM(GMSK, 1-Slot)	32.51	32.38	32.13	30.16	29.75	29.61
GPRS (GMSK, 1-Slot)	32.57	32.47	32.20	30.23	29.75	29.62
GPRS (GMSK, 2-Slot)	32.13	32.03	31.70	29.82	29.11	28.85
GPRS (GMSK, 3-Slot)	30.88	30.72	30.37	28.71	27.62	27.10
GPRS (GMSK, 4-Slot)	29.87	29.73	29.35	27.79	26.52	26.98
EGPRS(8PSK, 1-Slot)	29.82	29.61	29.58	29.28	29.52	29.97
EGPRS(8PSK, 2-Slot)	27.30	28.37	27.53	27.42	27.03	28.59
EGPRS(8PSK, 3-Slot)	27.47	26.56	26.01	27.16	26.73	26.80
EGPRS(8PSK, 4-Slot)	26.56	26.17	25.54	26.33	25.74	26.01

Fram- RF Output Power (dBm)						
Band	GSM 850			PCS 1900		
Channel	128	190	251	512	661	810
Frequency (MHz)	824.2	836.6	848.8	1850.2	1880	1909.8
GSM(GMSK, 1-Slot)	23.48	23.35	23.10	21.13	20.72	20.58
GPRS (GMSK, 1-Slot)	23.54	23.44	23.17	21.20	20.72	20.59
GPRS (GMSK, 2-Slot)	26.11	26.01	25.68	23.80	23.09	22.83
GPRS (GMSK, 3-Slot)	26.62	26.46	26.11	24.45	23.36	22.84
GPRS (GMSK, 4-Slot)	26.86	26.72	26.34	24.78	23.51	23.97
EGPRS(8PSK, 1-Slot)	20.79	20.58	20.55	20.25	20.49	20.94
EGPRS(8PSK, 2-Slot)	21.28	22.35	21.51	21.40	21.01	22.57
EGPRS(8PSK, 3-Slot)	23.21	22.30	21.75	22.90	22.47	22.54
EGPRS(8PSK, 4-Slot)	23.55	23.16	22.53	23.32	22.73	23.00



WCDMA

Band	WCDMA Band II			WCDMA Band V			WCDMA Band IV		
Channel	9262	9400	9538	4132	4183	4233	1312	1413	1513
Frequency (MHz)	1852.4	1880	1907.6	826.4	836.6	846.6	1712.6	1740	1752.4
RMC 12.2Kbps	23.93	23.83	24.48	24.31	24.27	24.30	23.81	23.25	23.66
HSDPA Subtest-1	23.71	23.68	23.65	23.83	23.82	23.71	23.54	23.24	23.09
HSDPA Subtest-2	23.72	23.69	23.64	23.76	23.74	23.68	23.90	23.18	23.31
HSDPA Subtest-3	23.69	23.67	23.65	23.75	23.68	23.65	23.58	23.05	23.84
HSDPA Subtest-4	23.68	23.66	23.65	23.78	23.72	23.69	23.98	23.34	23.60
HSUPA Subtest-1	23.96	23.93	23.89	23.84	23.90	23.83	23.62	23.85	23.88
HSUPA Subtest-2	23.95	23.90	23.91	23.85	23.86	23.83	23.80	23.50	23.70
HSUPA Subtest-3	23.94	23.92	23.91	23.89	23.90	23.86	23.89	23.32	23.16
HSUPA Subtest-4	23.97	23.95	23.91	23.87	23.86	23.85	23.11	23.82	23.26
HSUPA Subtest-5	23.96	23.92	23.90	23.88	23.87	23.89	23.24	23.11	23.87

According to 3GPP 25.101 sub-clause 6.2.2, the maximum output power is allowed to be reduced by following the table.

Table 6.1A: UE maximum output power with HS-DPCCH and E-DCH

UE Transmit Channel Configuration	CM(db)	MPR(db)
For all combinations of ,DPDCH,DPCCH HS-DPDCH,E-DPDCH and E-DPCCH	$0 \leq CM \leq 3.5$	MAX(CM-1,0)
Note: CM=1 for $\beta_c/\beta_d=12/15$, $\beta_{hs}/\beta_c=24/15$.For all other combinations of DPDCH, DPCCH, HS-DPCCH, E-DPDCH and E-DPCCH the MPR is based on the relative CM difference.		

The device supports MPR to solve linearity issues (ACLR or SEM) due to the higher peak-to average ratios (PAR) of the HSUPA signal. This prevents saturating the full range of the TX DAC inside of device and provides a reduced power output to the RF transceiver chip according to the Cubic Metric (a function of the combinations of DPDCH, DPCCH, HS-DPCCH, E-DPDCH and E-DPCCH).

When E-DPDCH channels are present the beta gains on those channels are reduced firsts to try to get the power under the allowed limit. If the beta gains are lowered as far as possible, then a hard limiting is applied at the maximum allowed level.

The SW currently recalculates the cubic metric every time the beta gains on the E-DPDCH are reduced. The cubic metric will likely get lower each time this is done .However, there is no reported reduction of maximum output power in the HSUPA mode since the device also provides a compensation for the power back-off by increasing the gain of TX_AGC in the transceiver (PA) device.

The end effect is that the DUT output power is identical to the case where there is no MPR in the device.

**2.4G WLAN**

Mode	Channel Number	Frequency (MHz)	Average Power (dBm)
802.11b	1	2412	13.07
	7	2442	13.49
	11	2462	13.36
802.11g	1	2412	8.11
	7	2442	8.45
	11	2462	8.42
802.11n(HT 20)	1	2412	8.24
	7	2442	8.64
	11	2462	8.31
802.11n(HT 40)	3	2422	8.18
	6	2437	8.30
	9	2452	8.31

Bluetooth

Mode	Channel Number	Frequency (MHz)	Average Power (dBm)
GFSK(1Mbps)	0	2402	0.78
	39	2441	0.16
	78	2480	0.67
$\pi/4$ -DQPSK(2Mbps)	0	2402	0.55
	39	2441	0.49
	78	2480	0.78
8DPSK(3Mbps)	0	2402	0.33
	39	2441	0.78
	78	2480	0.69

BLE

Mode	Channel Number	Frequency (MHz)	Average Power (dBm)
GFSK(1Mbps)	0	2402	0.18
	19	2440	0.33
	39	2480	0.17



LTE Conducted Power

General Note:

1. Anritsu CMW500 base station simulator was used to setup the connection with EUT; the frequency band, channel bandwidth, RB allocation configuration, modulation type are set in the base station simulator to configure EUT transmitting at maximum power and at different configurations which are requested to be reported to FCC, for conducted power measurement and SAR testing.
2. Per KDB 941225 D05, when a properly configured base station simulator is used for the SAR and power measurements, spectrum plots for each RB allocation and offset configuration is not required.
3. Per KDB 941225 D05, start with the largest channel bandwidth and measure SAR for QPSK with 1 RB allocation, using the RB offset and required test channel combination with the highest maximum output power for RB offsets at the upper edge, middle and lower edge of each required test channel.
4. Per KDB 941225 D05, 50% RB allocation for QPSK SAR testing follows 1RB QPSK allocation procedure.
5. Per KDB 941225 D05, For QPSK with 100% RB allocation, SAR is not required when the highest maximum output power for 100 % RB allocation is less than the highest maximum output power in 50% and 1 RB allocations and the highest reported SAR for 1 RB and 50% RB allocation are ≤ 0.8 W/kg. Otherwise, SAR is measured for the highest output power channel; and if the reported SAR is > 1.45 W/kg, the remaining required test channels must also be tested.
6. Per KDB 941225 D05, 16QAM output power for each RB allocation configuration is $>$ not $\frac{1}{2}$ dB higher than the same configuration in QPSK and the reported SAR for the QPSK configuration is ≤ 1.45 W/kg; Per KDB 941225 D05, 16QAM SAR testing is not required.
7. Per KDB 941225 D05, Smaller bandwidth output power for each RB allocation configuration is $>$ not $\frac{1}{2}$ dB higher than the same configuration in the largest supported bandwidth, and the reported SAR for the largest supported bandwidth is ≤ 1.45 W/kg; Per KDB 941225 D05, smaller bandwidth SAR testing is not required





LTE Band 2

LTE Band 2 Maximum Average Power [dBm]						
BW [MHz]	RB Size	RB Offset	Mod	Lowest	Middle	Highest
1.4	1	0	QPSK	21.95	22.12	22.16
1.4	1	2		21.80	22.28	22.32
1.4	1	5		22.07	22.10	22.03
1.4	3	0		22.90	22.12	22.17
1.4	3	1		21.76	22.10	22.05
1.4	3	2		21.73	22.27	22.07
1.4	6	0		20.82	21.32	21.21
1.4	1	0	16-QAM	21.08	21.25	21.30
1.4	1	2		21.50	21.39	21.36
1.4	1	5		21.28	21.26	20.98
1.4	3	0		20.41	21.01	20.97
1.4	3	1		20.48	21.32	20.81
1.4	3	2		20.78	21.34	21.02
1.4	6	0		20.96	20.97	20.94
3	1	0	QPSK	21.89	22.11	22.48
3	1	7		21.67	22.13	22.16
3	1	14		21.86	22.29	22.47
3	8	0		20.88	21.27	21.28
3	8	4		20.88	21.32	21.28
3	8	7		20.91	21.16	21.20
3	15	0		20.89	21.25	21.21
3	1	0	16-QAM	20.75	21.09	21.19
3	1	7		20.67	21.36	21.09
3	1	14		21.15	21.39	21.28
3	8	0		20.92	20.36	20.44
3	8	4		20.95	20.35	20.33
3	8	7		20.98	20.39	20.35
3	15	0		20.96	21.22	20.99



LTE Band 2 Maximum Average Power [dBm]						
BW [MHz]	RB Size	RB Offset	Mod.	Lowest	Middle	Highest
5	1	0	QPSK	20.61	21.62	21.58
5	1	12		20.81	21.60	21.76
5	1	24		21.34	21.83	21.92
5	12	0		20.51	20.72	20.74
5	12	6		20.95	20.75	20.73
5	12	11		20.39	20.68	20.73
5	25	0		20.30	20.72	20.74
5	1	0	16-QAM	20.54	20.50	21.25
5	1	12		20.87	20.57	20.61
5	1	24		20.93	20.69	20.67
5	12	0		20.75	20.86	21.79
5	12	6		21.18	20.86	20.82
5	12	11		21.46	20.91	21.72
5	25	0		21.20	20.75	21.83
10	1	0	QPSK	21.73	22.16	22.26
10	1	24		21.88	21.87	22.03
10	1	49		21.84	21.94	21.99
10	25	0		20.58	21.07	21.02
10	25	12		20.59	21.00	20.96
10	25	24		20.83	20.87	20.93
10	50	0		20.73	20.97	20.94
10	1	0	16-QAM	20.78	21.28	20.96
10	1	24		20.99	21.04	21.02
10	1	49		20.65	21.12	20.75
10	25	0		20.61	20.96	21.03
10	25	12		20.63	21.24	20.95
10	25	24		20.80	20.90	20.91
10	50	0		20.77	21.05	20.90



LTE Band 2 Maximum Average Power [dBm]						
BW [MHz]	RB Size	RB Offset	Mod.	Lowest	Middle	Highest
15	1	0	QPSK	21.84	22.17	22.39
15	1	37		21.67	21.80	21.84
15	1	74		22.26	22.31	22.12
15	36	0		20.51	21.35	21.88
15	36	18		20.36	20.85	21.09
15	36	39		21.26	21.40	21.11
15	75	0		20.84	21.18	21.04
15	1	0	16-QAM	20.66	21.45	21.20
15	1	38		20.53	21.20	20.94
15	1	75		21.07	21.21	21.11
15	36	0		20.75	21.32	20.09
15	36	18		20.40	21.12	21.06
15	36	39		21.02	21.22	21.14
15	75	0		20.90	20.97	20.90
20	1	0	QPSK	21.75	22.29	22.12
20	1	49		22.00	21.85	22.24
20	1	99		22.42	22.25	21.96
20	50	0		20.69	21.27	21.25
20	50	24		20.86	21.20	21.14
20	50	49		21.18	21.00	21.03
20	100	0		20.83	21.15	21.13
20	1	0	16-QAM	20.90	21.39	21.22
20	1	49		21.02	21.10	21.16
20	1	99		21.39	21.42	21.09
20	50	0		21.94	20.93	20.97
20	50	24		21.94	20.64	20.96
20	50	49		21.03	20.96	20.88
20	100	0		20.91	20.92	20.96



LTE Band 4

LTE Band 4 Maximum Average Power [dBm]						
BW [MHz]	RB Size	RB Offset	Mod	Lowest	Middle	Highest
1.4	1	0	QPSK	21.28	22.40	22.23
1.4	1	2		22.30	22.49	22.39
1.4	1	5		22.24	22.42	22.26
1.4	3	0		22.13	22.55	22.28
1.4	3	1		22.20	22.36	22.28
1.4	3	2		22.35	22.38	22.28
1.4	6	0		21.15	21.52	21.37
1.4	1	0	16-QAM	21.42	21.57	21.53
1.4	1	2		21.42	21.69	21.64
1.4	1	5		20.82	21.55	21.47
1.4	3	0		21.20	21.47	21.25
1.4	3	1		21.19	21.30	21.25
1.4	3	2		21.31	21.40	21.45
1.4	6	0		20.60	20.49	20.97
3	1	0	QPSK	22.45	22.58	22.73
3	1	7		22.18	22.23	22.38
3	1	14		22.46	22.41	22.49
3	8	0		21.35	21.79	21.63
3	8	4		21.61	21.68	21.62
3	8	7		21.38	21.58	21.47
3	15	0		21.41	21.61	21.47
3	1	0	16-QAM	21.48	21.34	21.58
3	1	7		21.28	21.78	21.42
3	1	14		21.19	21.75	21.16
3	8	0		20.77	20.73	20.64
3	8	4		20.68	20.73	20.73
3	8	7		20.56	20.86	20.39
3	15	0		20.48	20.63	20.42



LTE Band 4 Maximum Average Power [dBm]						
BW [MHz]	RB Size	RB Offset	Mod	Lowest	Middle	Highest
5	1	0	QPSK	22.50	22.58	22.56
5	1	12		22.31	22.56	22.28
5	1	24		22.69	22.63	22.48
5	12	0		21.49	21.81	21.62
5	12	6		21.52	21.66	21.62
5	12	11		21.54	21.63	21.65
5	25	0		21.54	21.70	21.65
5	1	0	16-QAM	21.64	21.58	21.64
5	1	12		21.53	21.39	20.92
5	1	24		21.81	21.64	21.54
5	12	0		20.72	20.70	20.94
5	12	6		20.73	20.75	20.61
5	12	11		20.54	20.74	20.62
5	25	0		20.55	20.77	20.53
10	1	0	QPSK	22.62	22.65	22.70
10	1	24		22.52	22.60	22.58
10	1	49		22.63	22.43	22.53
10	25	0		21.56	21.75	21.51
10	25	12		21.56	21.67	21.59
10	25	24		21.66	21.65	21.66
10	50	0		21.52	21.68	21.53
10	1	0	16-QAM	21.65	21.88	21.64
10	1	24		21.33	21.85	21.31
10	1	49		21.61	21.78	21.62
10	25	0		20.49	20.70	20.65
10	25	12		20.49	20.70	20.65
10	25	24		20.58	20.66	20.69
10	50	0		20.50	20.75	20.55



LTE Band 4 Maximum Average Power [dBm]						
BW [MHz]	RB Size	RB Offset	Mod	Lowest	Middle	Highest
15	1	0	QPSK	22.42	22.60	22.38
15	1	37		22.31	22.18	22.29
15	1	74		22.74	22.21	22.60
15	36	0		21.25	22.02	21.21
15	36	18		21.22	21.33	20.83
15	36	39		21.74	21.29	22.18
15	75	0		21.45	21.53	21.37
15	1	0	16-QAM	21.37	21.90	21.36
15	1	38		21.26	21.61	21.31
15	1	75		21.45	21.47	21.35
15	36	0		21.24	21.75	21.26
15	36	18		21.14	21.32	20.81
15	36	39		21.60	21.33	22.08
15	75	0		20.46	20.59	20.43
20	1	0	QPSK	22.58	23.01	22.56
20	1	49		22.56	22.29	22.38
20	1	99		22.81	22.22	22.52
20	50	0		21.30	21.70	21.24
20	50	24		21.37	21.57	21.31
20	50	49		21.59	21.21	21.36
20	100	0		21.46	21.57	21.30
20	1	0	16-QAM	20.87	21.90	21.68
20	1	49		21.50	21.62	21.13
20	1	99		21.41	21.43	21.53
20	50	0		20.40	21.45	20.42
20	50	24		20.51	20.53	20.52
20	50	49		20.38	20.45	20.36
20	100	0		20.32	20.55	20.30



LTE Band 5

LTE Band 5 Maximum Average Power [dBm]						
BW [MHz]	RB Size	RB Offset	Mod	Lowest	Middle	Highest
1.4	1	0	QPSK	23.45	23.43	23.70
1.4	1	2		23.60	23.44	23.62
1.4	1	5		23.56	23.38	23.51
1.4	3	0		23.40	23.38	23.67
1.4	3	1		23.40	23.56	23.59
1.4	3	2		23.44	23.40	23.47
1.4	6	0		22.47	22.37	22.69
1.4	1	0	16-QAM	22.76	22.56	22.86
1.4	1	2		22.96	22.54	22.94
1.4	1	5		22.75	22.73	22.82
1.4	3	0		22.12	22.66	22.69
1.4	3	1		22.12	22.66	22.49
1.4	3	2		22.41	22.57	22.37
1.4	6	0		21.34	21.32	21.74
3	1	0	QPSK	23.60	23.41	23.45
3	1	7		23.39	23.13	23.32
3	1	14		23.55	23.42	23.58
3	8	0		22.53	22.70	22.84
3	8	4		22.57	22.52	22.66
3	8	7		22.51	22.45	22.61
3	15	0		22.42	22.63	22.57
3	1	0	16-QAM	22.65	22.54	22.55
3	1	7		22.47	22.38	22.69
3	1	14		22.49	22.53	22.69
3	8	0		21.65	21.59	21.82
3	8	4		21.64	21.66	21.83
3	8	7		21.63	21.59	21.73
3	15	0		21.49	21.37	21.74



LTE Band 5 Maximum Average Power [dBm]						
BW [MHz]	RB Size	RB Offset	Mod	Lowest	Middle	Highest
5	1	0	QPSK	23.54	23.54	23.40
5	1	12		23.24	23.42	23.44
5	1	24		23.50	23.51	23.46
5	12	0		22.52	22.59	22.69
5	12	6		22.62	22.51	22.58
5	12	11		22.50	22.53	22.59
5	25	0		22.48	22.47	22.61
5	1	0	16-QAM	22.54	22.41	22.24
5	1	12		22.35	22.36	22.01
5	1	24		22.62	22.18	21.86
5	12	0		21.73	21.60	21.73
5	12	6		21.72	21.53	21.60
5	12	11		21.62	21.37	21.66
5	25	0		21.50	21.36	21.51
10	1	0	QPSK	23.29	23.73	23.76
10	1	24		23.29	23.51	23.62
10	1	49		23.40	23.47	23.32
10	25	0		22.44	22.63	22.57
10	25	12		22.42	22.49	22.49
10	25	24		22.54	22.53	22.50
10	50	0		22.44	22.57	22.49
10	1	0	16-QAM	22.65	22.56	22.40
10	1	24		22.60	22.53	22.58
10	1	49		22.70	22.49	22.46
10	25	0		21.62	21.57	21.24
10	25	12		21.49	21.57	21.41
10	25	24		21.42	21.61	21.41
10	50	0		21.51	21.63	21.52

11. EUT and Test Setup Photo

11.1 EUT Photo

Front side



Back side



Top side

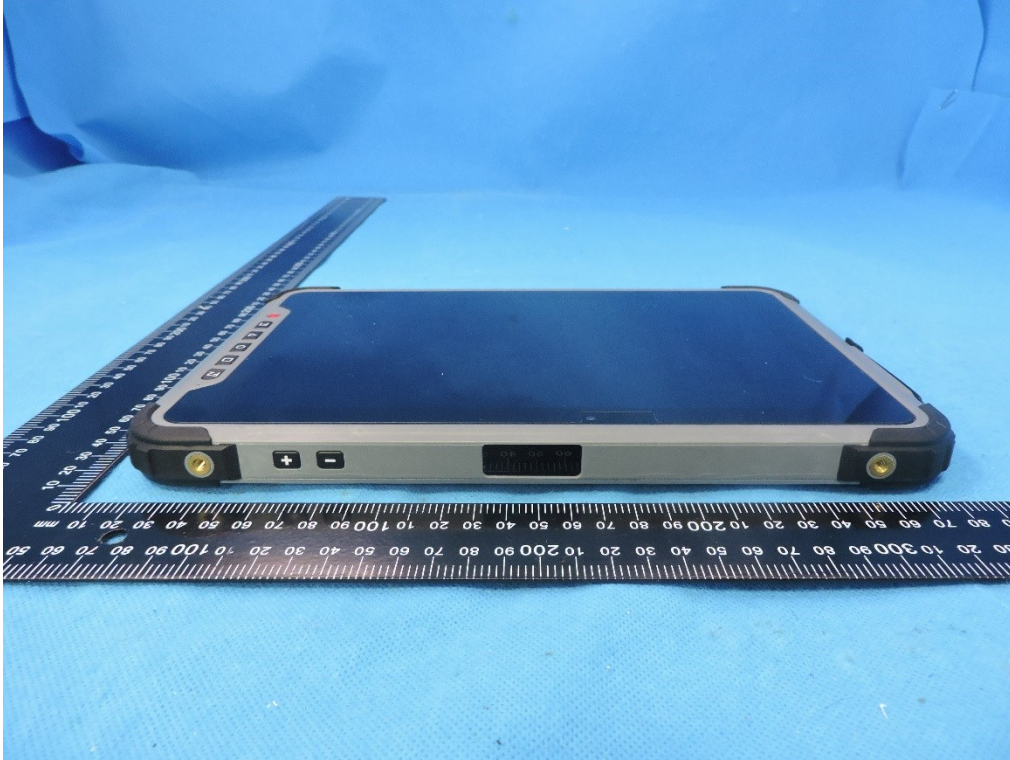

Bottom side

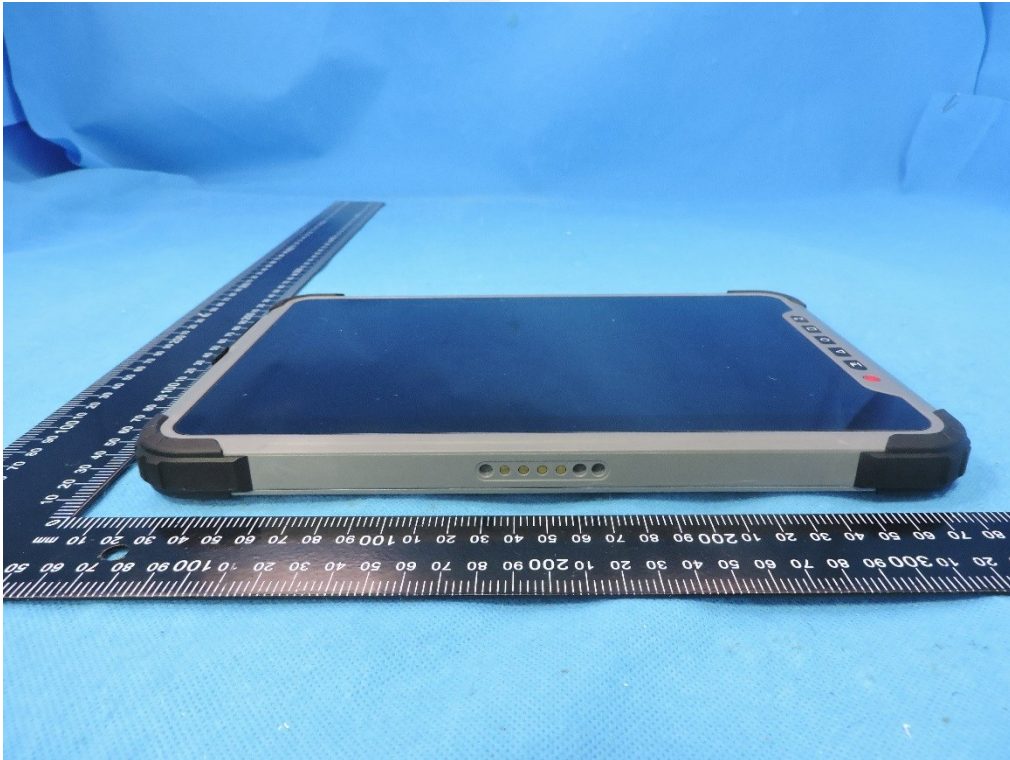

Left side



Right side

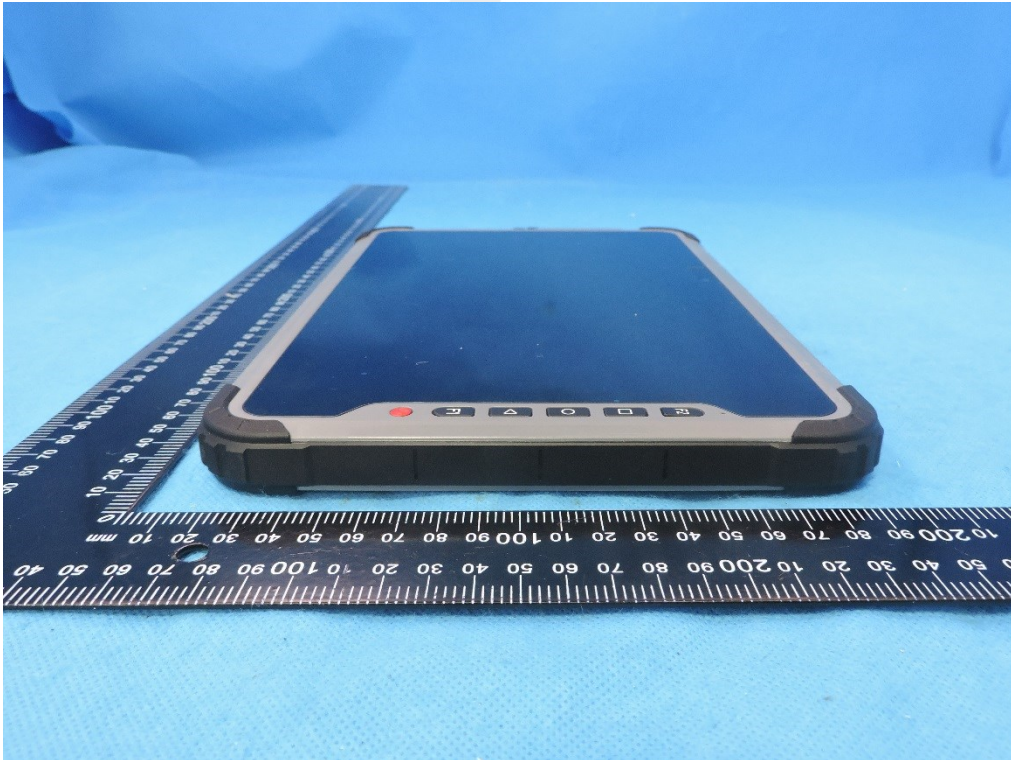

11.2 Setup Photo

Body Back side(separation distance is 0mm)



Body Left side(separation distance is 0mm)

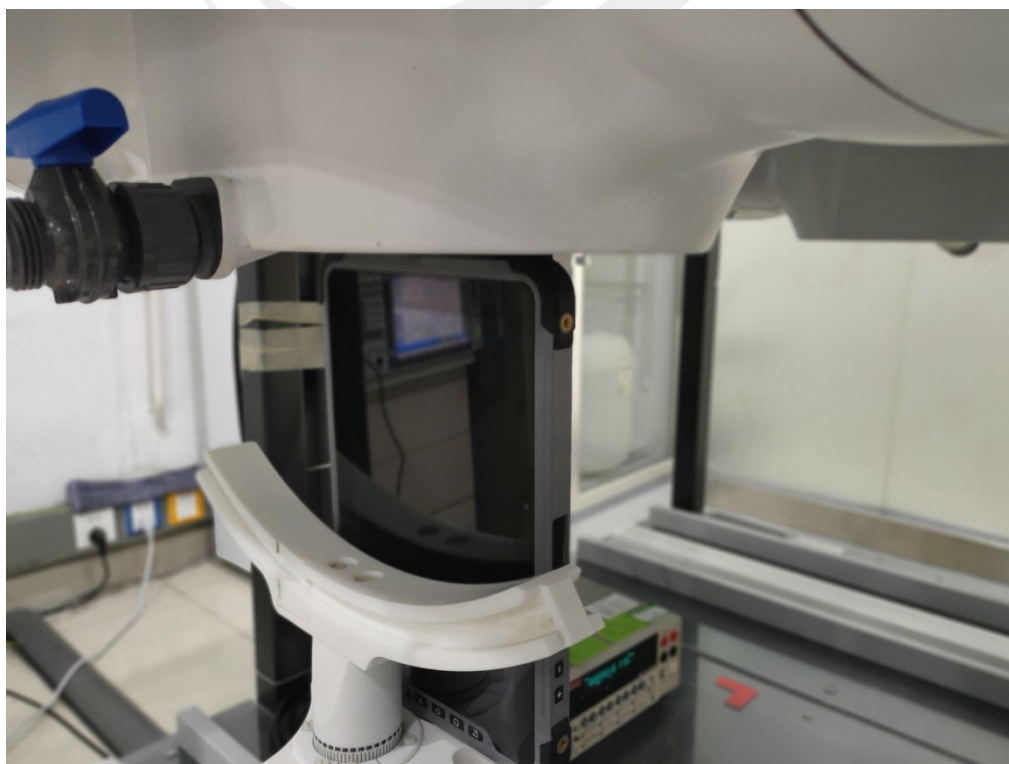

Body Right side(separation distance is 0mm)

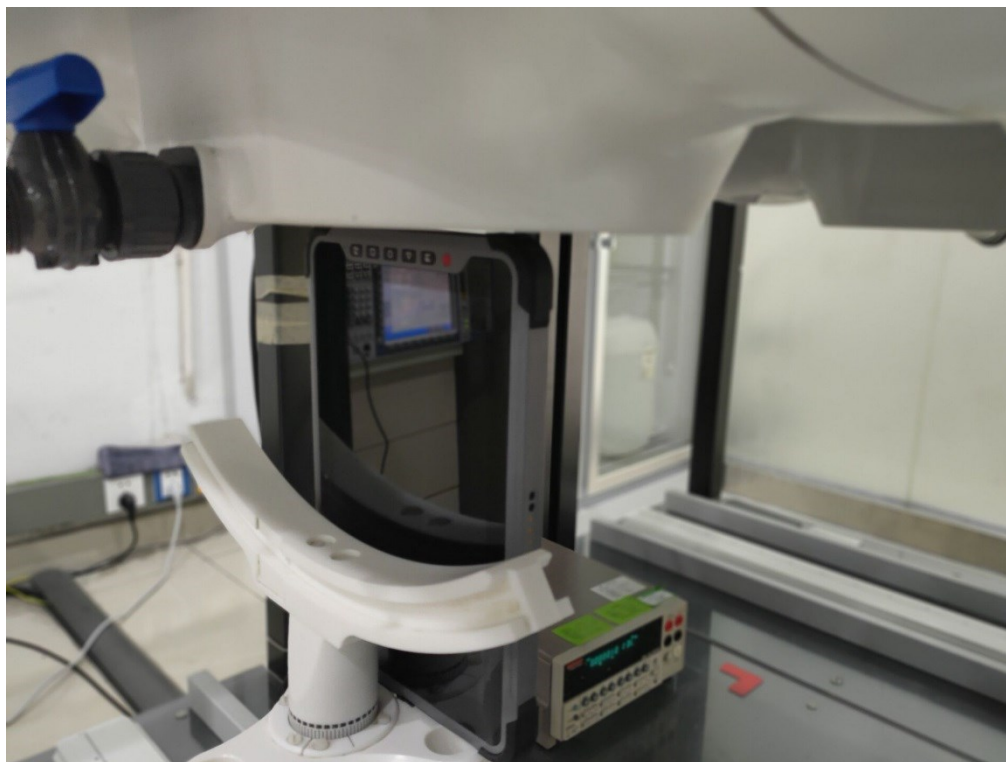

Body Bottom side(separation distance is 0mm)

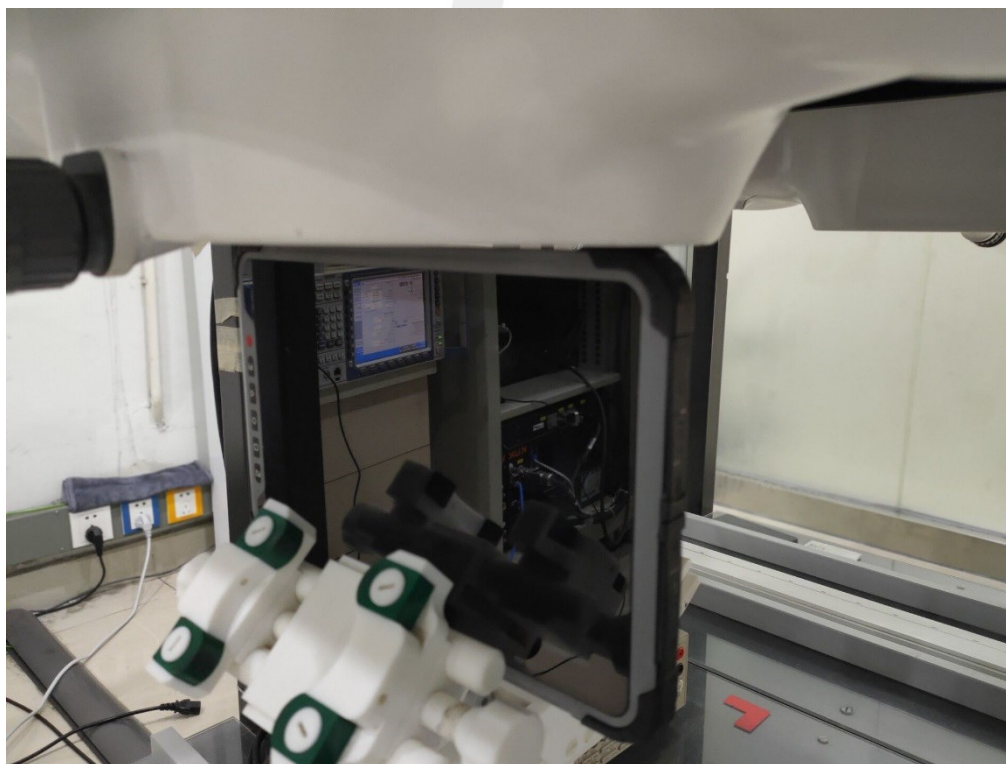



Body Top side(separation distance is 0mm)

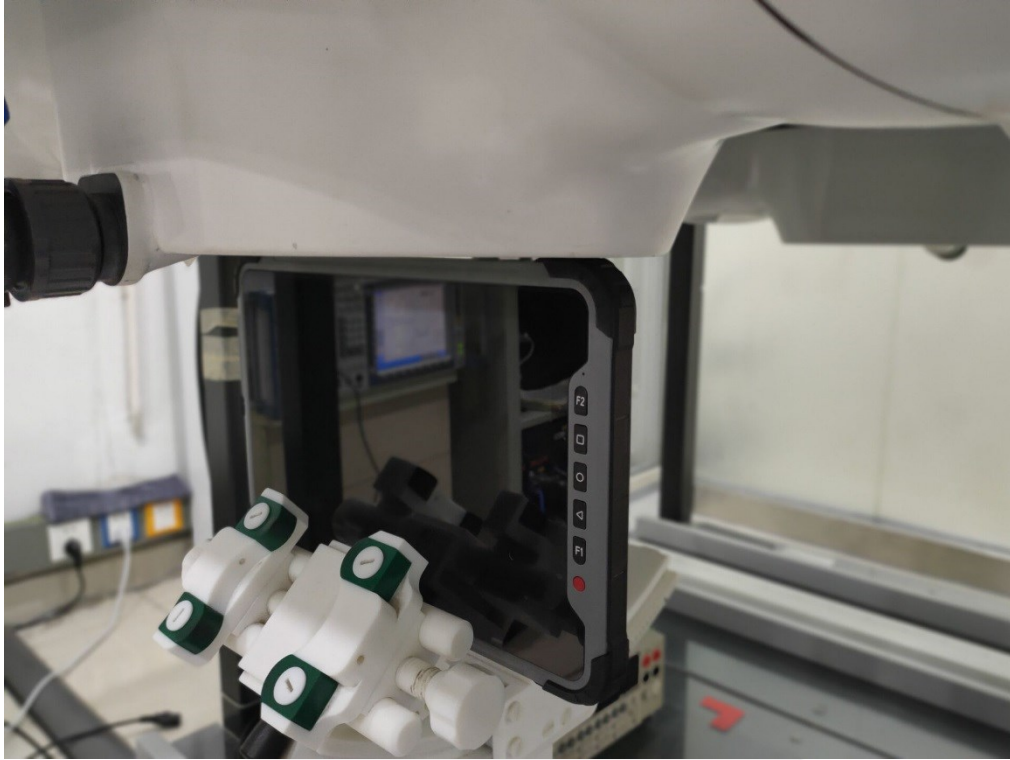

Liquid depth (15 cm)

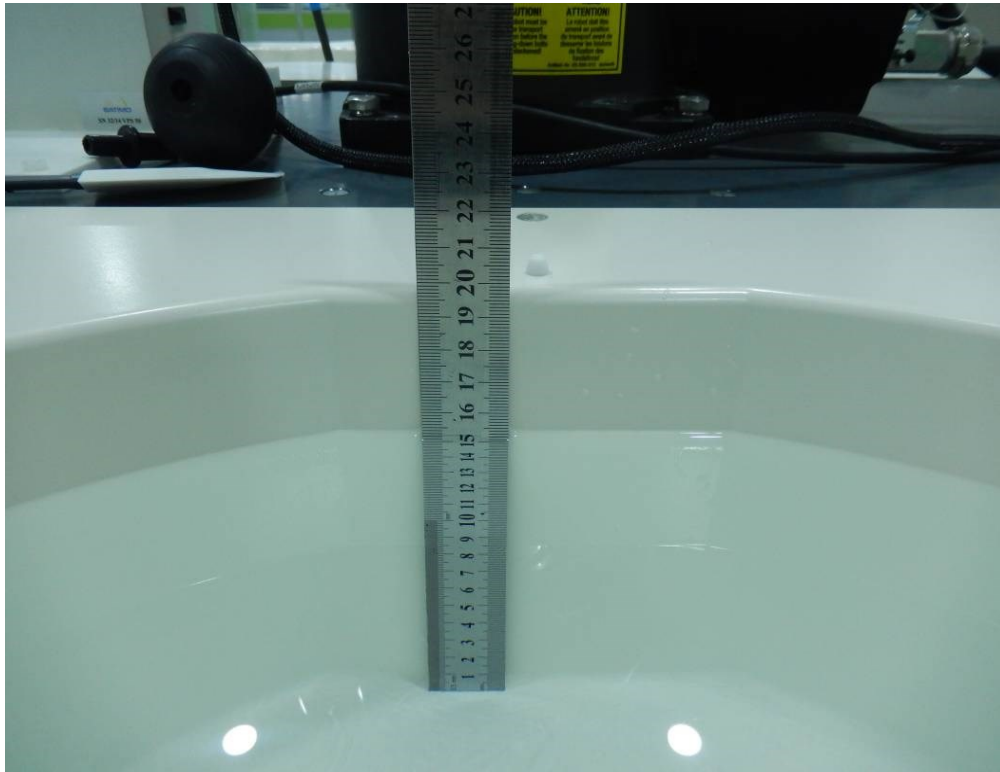



12. SAR Result Summary

12.1 Body-worn and Hotspot SAR

Band	Model	Test Position	Freq.	SAR (1g) (W/kg)	Power Drift(%)	Max.Turn-up Power(dBm)	Meas.Output Power(dBm)	Scaled SAR (W/Kg)	Meas.No.
GSM 850	GPRS (GMSK, 4-Slot)	Back Side	824.2	1.156	-3.04	30.00	29.87	1.191	1
		Back Side	836.6	0.863	-1.84	30.00	29.73	0.918	/
		Back Side	848.8	0.764	-3.55	30.00	29.35	0.887	/
		Left Edge	824.2	0.541	1.85	30.00	29.87	0.557	/
		Right Edge	824.2	0.500	2.13	30.00	29.87	0.515	/
		Top Edge	824.2	0.254	-3.20	30.00	29.87	0.262	/
		Bottom Edge	824.2	0.241	3.18	30.00	29.87	0.248	/
GSM1900	GPRS (GMSK, 4-Slot)	Back Side	1850.2	1.167	-2.82	28.00	27.79	1.225	2
		Back Side	1880	0.869	0.79	28.00	26.52	1.222	/
		Back Side	1909.8	0.711	-3.61	28.00	26.98	0.899	/
		Right Edge	1850.2	0.323	-2.59	28.00	27.79	0.339	/
		Top Edge	1850.2	0.310	-3.40	28.00	27.79	0.325	/
		Bottom Edge	1850.2	0.587	1.83	28.00	27.79	0.616	/
WCDMA Band II	RMC	Back Side	1852.4	0.574	0.48	24.50	23.93	0.655	/
		Back Side	1880	0.617	-2.11	24.50	23.83	0.720	/
		Back Side	1907.6	0.922	1.39	24.50	24.48	0.926	3
		Right Edge	1907.6	0.583	1.89	24.50	24.48	0.586	/
		Top Edge	1907.6	0.387	-3.37	24.50	24.48	0.389	/
		Bottom Edge	1907.6	0.283	2.76	24.50	24.48	0.284	/
WCDMA Band IV	RMC	Back Side	1712.6	1.036	2.23	24.50	24.31	1.082	4
		Back Side	1740	0.746	-3.87	24.50	24.27	0.787	/
		Back Side	1752.4	0.617	2.89	24.50	24.30	0.646	/
		Right Edge	1712.6	0.410	-0.48	24.50	24.31	0.428	/
		Top Edge	1712.6	0.219	-0.82	24.50	24.31	0.229	/
WCDMA Band V	RMC	Back Side	826.4	1.124	3.33	24.00	23.81	1.174	5
		Back Side	836.6	0.843	1.22	24.00	23.25	1.002	/
		Back Side	846.6	0.715	-2.97	24.00	23.66	0.773	/
		Right Edge	826.4	0.555	1.98	24.00	23.81	0.580	/
		Top Edge	826.4	0.213	3.07	24.00	23.81	0.223	/



Band	BW (MHz)	Mod.	RB Size	RB offset	Test Position	Freq.	Result 1g (W/Kg)	Power Drift(%)	Max. Turn-up Power (dBm)	Meas. Output Power(dBm)	Scaled SAR (W/Kg)	Meas.No.
LTE Band 2	20M	QPSK	1	99	Back Side	1860	0.933	0.61	22.5	22.42	0.950	6
			50	0	Back Side	1860	0.710	2.66	22.5	21.27	0.942	/
			100	0	Back Side	1860	0.687	-0.74	22.5	21.15	0.937	/
			1	99	Back Side	1880	0.889	3.01	22.5	22.42	0.906	/
			50	0	Back Side	1880	0.685	-1.66	22.5	21.27	0.909	/
			100	0	Back Side	1880	0.695	2.77	22.5	21.15	0.948	/
			1	99	Back Side	1900	0.644	0.76	22.5	22.42	0.656	/
			50	0	Back Side	1900	0.613	3.13	22.5	21.27	0.814	/
			100	0	Back Side	1900	0.541	-0.40	22.5	21.15	0.738	/
			1	99	Right Side	1860	0.491	-1.99	22.5	22.42	0.500	/
			50	0	Right Side	1860	0.483	-1.08	22.5	21.27	0.641	/
			100	0	Right Side	1860	0.471	-2.81	22.5	21.15	0.643	/
			1	99	Top Edge	1860	0.362	0.39	22.5	22.42	0.369	/
			50	0	Top Edge	1860	0.354	2.63	22.5	21.27	0.470	/
			100	0	Top Edge	1860	0.510	-0.73	22.5	21.15	0.696	/



LTE Band 4	20M	QPSK	1	0	Back Side	1720	0.697	1.01	23.5	23.01	0.780	/
			50	0	Back Side	1720	0.612	3.75	23.5	21.7	0.926	/
			100	0	Back Side	1720	0.561	-1.84	23.5	21.57	0.875	/
			1	0	Back Side	1732.5	0.823	0.13	23.5	23.01	0.921	7
			50	0	Back Side	1732.5	0.800	0.22	23.5	21.7	1.211	/
			100	0	Back Side	1732.5	0.777	-2.64	23.5	21.57	1.212	/
			1	0	Back Side	1745	0.611	-0.51	23.5	23.01	0.684	/
			50	0	Back Side	1745	0.584	-1.94	23.5	21.7	0.884	/
			100	0	Back Side	1745	0.533	-0.98	23.5	21.57	0.831	/
			1	0	Right Side	1732.5	0.577	-1.63	23.5	23.01	0.646	/
			50	0	Right Side	1732.5	0.571	-0.74	23.5	21.7	0.864	/
			100	0	Right Side	1732.5	0.489	-0.45	23.5	21.57	0.763	/
			1	0	Top Edge	1732.5	0.481	0.26	23.5	23.01	0.538	/
			50	0	Top Edge	1732.5	0.474	-2.19	23.5	21.7	0.717	/
			100	0	Top Edge	1732.5	0.436	1.22	23.5	21.57	0.680	/



LTE Band 5	10M	QPSK	1	0	Back Side	829	0.676	1.16	24.00	23.76	0.714	/
			25	0	Back Side	829	0.711	1.46	24.00	22.63	0.975	/
			50	0	Back Side	829	0.734	1.32	24.00	22.57	1.020	/
			1	0	Back Side	836.5	0.847	-2.54	24.00	23.76	0.895	/
			25	0	Back Side	836.5	0.824	-3.47	24.00	22.63	1.130	/
			50	0	Back Side	836.5	0.810	-3.75	24.00	22.57	1.126	/
			1	0	Back Side	844	1.115	-2.28	24.00	23.76	1.178	8
			25	0	Back Side	844	0.845	1.75	24.00	22.63	1.158	/
			50	0	Back Side	844	0.836	2.49	24.00	22.57	1.162	/
			1	0	Right Side	844	0.562	-3.96	24.00	23.76	0.594	/
			25	0	Right Side	844	0.555	-0.58	24.00	22.63	0.761	/
			50	0	Right Side	844	0.510	2.10	24.00	22.57	0.709	/
			1	0	Top Edge	844	0.443	-2.58	24.00	23.76	0.468	/
			25	0	Top Edge	844	0.412	1.54	24.00	22.63	0.565	/
			50	0	Top Edge	844	0.397	-1.78	24.00	22.57	0.552	/



Band	Model	Test Position	Freq.	SAR (1g) (W/kg)	Power Drift(%)	Max.Turn-up Power(dBm)	Meas.Output Power(dBm)	Scaled SAR (W/Kg)	Meas.No.
2.4G WLAN	802.11b	Back Side	2437	0.329	2.52	13.50	13.49	0.330	11
		Left Edge	2437	0.134	-0.80	13.50	13.49	0.134	/
		Top Edge	2437	0.121	1.56	13.50	13.49	0.121	/

Note:

1. The test separation of all above table is 0mm.
2. Per KDB 447498 D01, the reported SAR is the measured SAR value adjusted for maximum tune-up tolerance.
 - a. Tune-up scaling Factor = tune-up limit power (mW) / EUT RF power (mW), where tune-up limit is the maximum rated power among all production units.
 - b. For WWAN: Scaled SAR(W/kg)= Measured SAR(W/kg)*Tune-up Scaling Factor
3. Per KDB 248227- When the highest reported SAR for DSSS is adjusted by the ratio of OFDM to DSSS specified maximum output power and the adjusted SAR is ≤ 1.2 W/kg. (The highest reported SAR for DSSS is adjusted by the ratio of OFDM to DSSS specified maximum output power was **0.330** W/Kg for Body)
4. When the user enables the personal Wireless router functions for the handsets, actual operations include simultaneous transmission of both the Wi-Fi transmitting frequency and thus cannot be evaluated for SAR under actual use conditions. The "Portable Hotspot" feature on the handset was NOT activated, to ensure the SAR measurements were evaluated for a single transmission frequency RF signal.



Repeated SAR

Band	Mode	Test Position	Freq.	Result 1g (W/Kg)	Power Drift(%)	Max.Turn-up Power(dBm)	Meas.Output Power(dBm)	Scaled SAR(W/Kg)	Meas. No.
GSM 850	GPRS Data-4 Slot	Back Side	824.2	0.997	1.26	30	29.87	1.027	-
		Back Side	836.6	0.844	0.87	30	29.73	0.898	-
		Back Side	848.8	0.762	-3.76	30	29.35	0.885	-
GSM 1900	GPRS Data-4 Slot	Back Side	1850.2	1.124	3.91	28.00	27.79	1.180	-
		Back Side	1880	0.847	-3.86	28.00	26.52	1.191	-
		Back Side	1909.8	0.683	3.79	28.00	26.98	0.864	-
WCDMA Band II	RMC	Back Side	1852.4	0.563	0.24	24.50	23.93	0.642	-
		Back Side	1880	0.597	1.08	24.50	23.83	0.697	-
		Back Side	1907.6	0.900	-3.38	24.50	24.48	0.904	-
WCDMA Band V	RMC	Back Side	826.4	1.032	-2.50	24.50	24.31	1.078	-
		Back Side	836.6	0.735	2.03	24.50	24.27	0.775	-
		Back Side	846.6	0.599	2.93	24.50	24.30	0.627	-
WCDMA Band IV	RMC	Back Side	1712.6	1.094	-2.35	24.00	23.25	1.300	-
		Back Side	1740	0.814	-0.33	24.00	23.66	0.880	-
		Back Side	1752.4	0.714	-0.53	24.00	23.81	0.746	-



LTE Band 2	QPSK	Back Side	1860	0.930	1.25	22.5	22.45	0.941	-
		Back Side	1880	0.879	3.02	22.5	22.25	0.931	-
		Back Side	1900	0.622	3.16	22.5	21.96	0.704	-
LTE Band 4	QPSK	Back Side	1720	0.665	3.80	23.5	22.58	0.822	-
		Back Side	1732.5	0.799	-1.03	23.5	23.01	0.894	-
		Back Side	1745	0.588	2.48	23.5	22.56	0.730	-
LTE Band 5	QPSK	Back Side	829	0.645	-3.91	24.00	23.29	0.760	-
		Back Side	836.5	0.807	-0.83	24.00	23.73	0.859	-
		Back Side	844	1.103	-3.23	24.00	23.76	1.166	-



12.2 Repeated SAR measurement

Band	Mode	Test Position	Freq.	Original Measured SAR 1g(W/kg)	1 st Repeated SAR 1g	Ratio	Original Measured SAR 1g(W/kg)	2nd Repeated SAR 1g	Ratio
GSM 850	GPRS Data-4 Slot	Back Side	824.2	1.156	0.997	1.159	-	-	-
		Back Side	836.6	0.863	0.844	1.023	-	-	-
		Back Side	848.8	0.764	0.762	1.003	-	-	-
PCS 1900	GPRS Data-4 Slot	Back Side	1850.2	1.167	1.124	1.038	-	-	-
		Back Side	1880	0.869	0.847	1.026	-	-	-
		Back Side	1909.8	0.711	0.683	1.041	-	-	-
WCDMA Band II	RMC	Back Side	1852.4	0.574	0.563	1.020	-	-	-
		Back Side	1880	0.617	0.597	1.034	-	-	-
		Back Side	1907.6	0.922	0.900	1.024	-	-	-
WCDMA Band V	RMC	Back Side	826.4	1.036	1.032	1.004	-	-	-
		Back Side	836.6	0.746	0.735	1.015	-	-	-
		Back Side	846.6	0.617	0.599	1.030	-	-	-
WCDMA Band IV	RMC	Back Side	1712.6	1.124	1.094	1.027	-	-	-
		Back Side	1740	0.843	0.814	1.036	-	-	-
		Back Side	1752.4	0.715	0.714	1.001	-	-	-



LTE Band 2	QPSK	Back Side	1860	0.933	0.930	1.003	-	-	-
		Back Side	1880	0.889	0.879	1.011	-	-	-
		Back Side	1900	0.644	0.622	1.035	-	-	-
LTE Band 4	QPSK	Back Side	1720	0.697	0.665	1.048	-	-	-
		Back Side	1732.5	0.823	0.799	1.030	-	-	-
		Back Side	1745	0.611	0.588	1.039	-	-	-
LTE Band 5	QPSK	Back Side	829	0.676	0.645	1.048	-	-	-
		Back Side	836.5	0.847	0.807	1.050	-	-	-
		Back Side	844	1.115	1.103	1.011	-	-	-

Note:

1. Per KDB 865664 D01, for each frequency band, repeated SAR measurement is required only when the measured SAR is $\geq 0.8\text{W/Kg}$.
2. Per KDB 865664 D01, if the ratio of largest to smallest SAR for the original and first repeated measurement is ≤ 1.2 and the measured SAR $< 1.45\text{W/Kg}$, only one repeated measurement is required.
3. Perform a second repeated measurement only if the ratio of largest to smallest SAR for the original and first repeated measurements is > 1.20 or when the original or repeated measurement is $\geq 1.45\text{W/Kg}$.
4. The ratio is the difference in percentage between original and repeated measured SAR.



Simultaneous Multi-band Transmission Evaluation:

Application Simultaneous Transmission information:

Position	Simultaneous State
Head	1. GSM + 2.4GHz WLAN
	2. GSM + Bluetooth
	3. WCDMA + 2.4GHz WLAN
	4. WCDMA + Bluetooth
	5. LTE + 2.4GHz WLAN
	6. LTE + Bluetooth
Body	1. GSM + 2.4GHz WLAN
	2. GSM + Bluetooth
	3. WCDMA + 2.4GHz WLAN
	4. WCDMA + Bluetooth
	5. LTE + 2.4GHz WLAN
	6. LTE + Bluetooth

NOTE:

1. Bluetooth and WLAN can't simultaneous transmission at the same time.
2. For simultaneous transmission at head and body exposure position, 2 transmitters simultaneous transmission was the worst state.
3. Based upon KDB 447498 D01, BT SAR is excluded as below table.
4. If the test separation distance is <5mm, 5mm is used for excluded SAR calculation.
5. For minimum test separation distance $\leq 50\text{mm}$, Bluetooth standalone SAR is excluded according to $[(\text{max. power of channel, including tune-up tolerance, mW}) / (\text{min. test separation distance, mm})] \cdot [\sqrt{f} (\text{GHz}) / x] \leq 3.0$ for 1-g SAR and ≤ 7.5 for 10-g extremity SAR
6. The reported SAR summation is calculated based on the same configuration and test position.
7. KDB 447498 / 4.3.2 (2) when standalone SAR test exclusion applies to an antenna that transmits simultaneously with other antennas, the standalone SAR must be estimated according to following to determine simultaneous transmission SAR test exclusion:
 - a) $(\text{max. power of channel, including tune-up tolerance, mW}) / (\text{min. test separation distance, mm}) \cdot [\sqrt{f} (\text{GHz}) / x] \text{ W/kg}$ for test separation distances $\leq 50 \text{ mm}$;
Where $x = 7.5$ for 1-g SAR, and $x = 18.75$ for 10-g SAR.
 - b) 0.4W/Kg for 1-g SAR and 1.0W/Kg for 10-g SAR, when the separation distance is $>50\text{mm}$.

Estimated SAR		Maximum Turn-up Power		Antenna to user(mm)	Frequency(GHz)	Stand Alone SAR(1g) [W/kg]
		dBm	mW			
BT	Body	1	1.259	5	2.48	0.053



Simultaneous Mode	Position	Mode	Max. 1-g SAR	1-g Sum SAR
			(W/kg)	(W/kg)
GSM + 2.4G WLAN	Body	GSM	1.225	1.555
		2.4G WLAN	0.330	
GSM + Bluetooth	Body	GSM	1.225	1.278
		Bluetooth	0.053	
WCDMA + 2.4G WLAN	Body	WCDMA	1.174	1.504
		2.4G WLAN	0.330	
WCDMA + Bluetooth	Body	WCDMA	1.174	1.227
		Bluetooth	0.053	
LTE + 2.4G WLAN	Body	LTE	1.178	1.508
		2.4G WLAN	0.330	
LTE + Bluetooth	Body	LTE	1.178	1.231
		Bluetooth	0.053	

Simultaneous transmission SAR test exclusion is determined for each operating configuration and exposure condition according to the reported standalone SAR of each applicable simultaneous transmitting antenna.

When the sum of SAR 1g of all simultaneously transmitting antennas in an operating mode and exposure condition combination is within the SAR limit (SAR-1g 1.6 W/kg), the simultaneous transmission SAR is not required. When the sum of SAR 1g is greater than the SAR limit (SAR-1g 1.6 W/kg), SAR test exclusion is determined by the SPLSR.



13. Equipment List

Kind of Equipment	Manufacturer	Type No.	Serial No.	Last Calibration	Calibrated Until
835MHz Dipole	MVG	SID835	SN 30/14 DIP0G835-332	2020.07.14	2023.07.13
900MHz Dipole	MVG	SID900	SN 30/14 DIP0G835-332	2020.07.14	2023.07.13
1800MHz Dipole	MVG	SID1800	SN 30/14 DIP1G800-329	2020.07.14	2023.07.13
1900MHz Dipole	MVG	SID1900	SN 30/14 DIP1G900-333	2020.07.14	2023.07.13
2450MHzDipole	MVG	SID2450	SN 30/14 DIP2G450-335	2020.07.14	2023.07.13
E-Field Probe	MVG	SSE2	SN 07/21 EPGO352	2021.03.01	2022.02.28
Dielectric Probe Kit	MVG	SCLMP	SN 32/14 OCPG67	2020.11.24	2021.11.23
Antenna	MVG	ANTA3	SN 07/13 ZNTA52	N/A	N/A
Phantom1	MVG	SAM	SN 32/14 SAM115	N/A	N/A
Phantom2	MVG	SAM	SN 32/14 SAM116	N/A	N/A
Phone holder	MVG	N/A	SN 32/14 MSH97	N/A	N/A
Laptop holder	MVG	N/A	SN 32/14 LSH29	N/A	N/A
Attenuator	Agilent	99899	DC-18GHz	N/A	N/A
Directional coupler	Narda	4226-20	3305	N/A	N/A
Network Analyzer	Agilent	8753ES	US38432810	2020.10.12	2021.10.11
Multi Meter	Keithley	Multi Meter 2000	4050073	2020.10.10	2021.10.09
Signal Generator	Agilent	N5182A	MY50140530	2020.10.10	2021.10.09
Wireless Communication Test Set	Agilent	8960-E5515C	MY48360751	2020.10.10	2021.10.09
Wireless Communication Test Set	R&S	CMW500	117239	2020.10.10	2021.10.09
Power Amplifier	DESAY	ZHL-42W	9638	2020.10.12	2021.10.11
Power Meter	R&S	NRP	100510	2020.10.10	2021.10.09
Power Meter	Agilent	E4419B	QB43312265	2020.10.10	2021.10.09
Power Sensor	R&S	NRP-Z11	101919	2020.10.10	2021.10.09
Power Sensor	HP	E9300A	US39210170	2020.10.10	2021.10.09
Temperature hygrometer	SuWei	SW-108	N/A	2020.10.12	2021.10.11
Thermograph	Elitech	RC-4	S/N EF7176501537	2020.10.12	2021.10.11

Note:

Per KDB 865664 D01, Dipole SAR Validation Verification, STS LAB has adopted 3 years calibration intervals. On annual basis, every measurement dipole has been evaluated and is in compliance with the following criteria:

1. There is no physical damage on the dipole
2. System validation with specific dipole is within 10% of calibrated value Return-loss in within 20% of calibrated measurement

Appendix A. System Validation Plots

System Performance Check Data (835MHz)

Type: Phone measurement (Complete)

Area scan resolution: dx=8mm, dy=8mm

Zoom scan resolution: dx=8mm, dy=8mm, dz=5mm

Date of measurement: 2021-09-12

Experimental conditions

Phantom	Validation plane
Device Position	-
Band	835MHz
Channels	-
Signal	CW
Frequency (MHz)	835MHz
Relative permittivity	41.64
Conductivity (S/m)	0.92
Probe	SN 07/21 EPG0352
ConvF:	1.57
Crest factor:	1:1

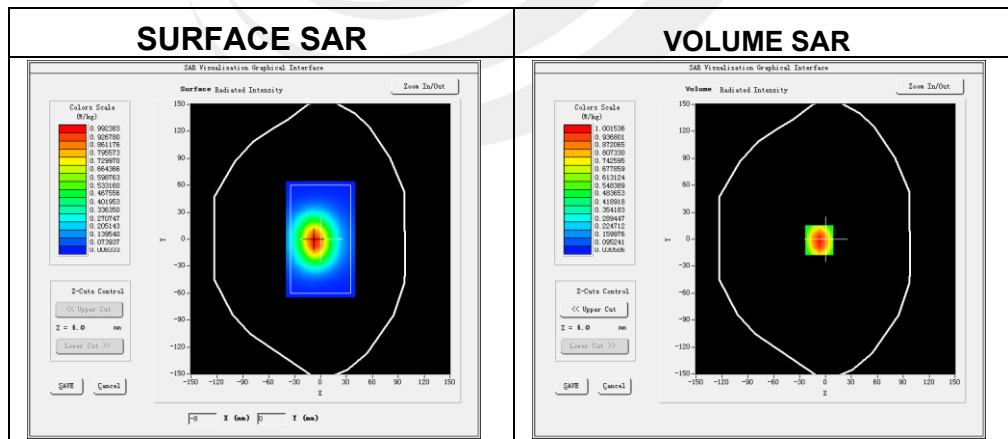

Maximum location: X=-7.00, Y=-1.00

SAR 10g (W/Kg)	0.645841
SAR 1g (W/Kg)	0.961931

Z Axis Scan

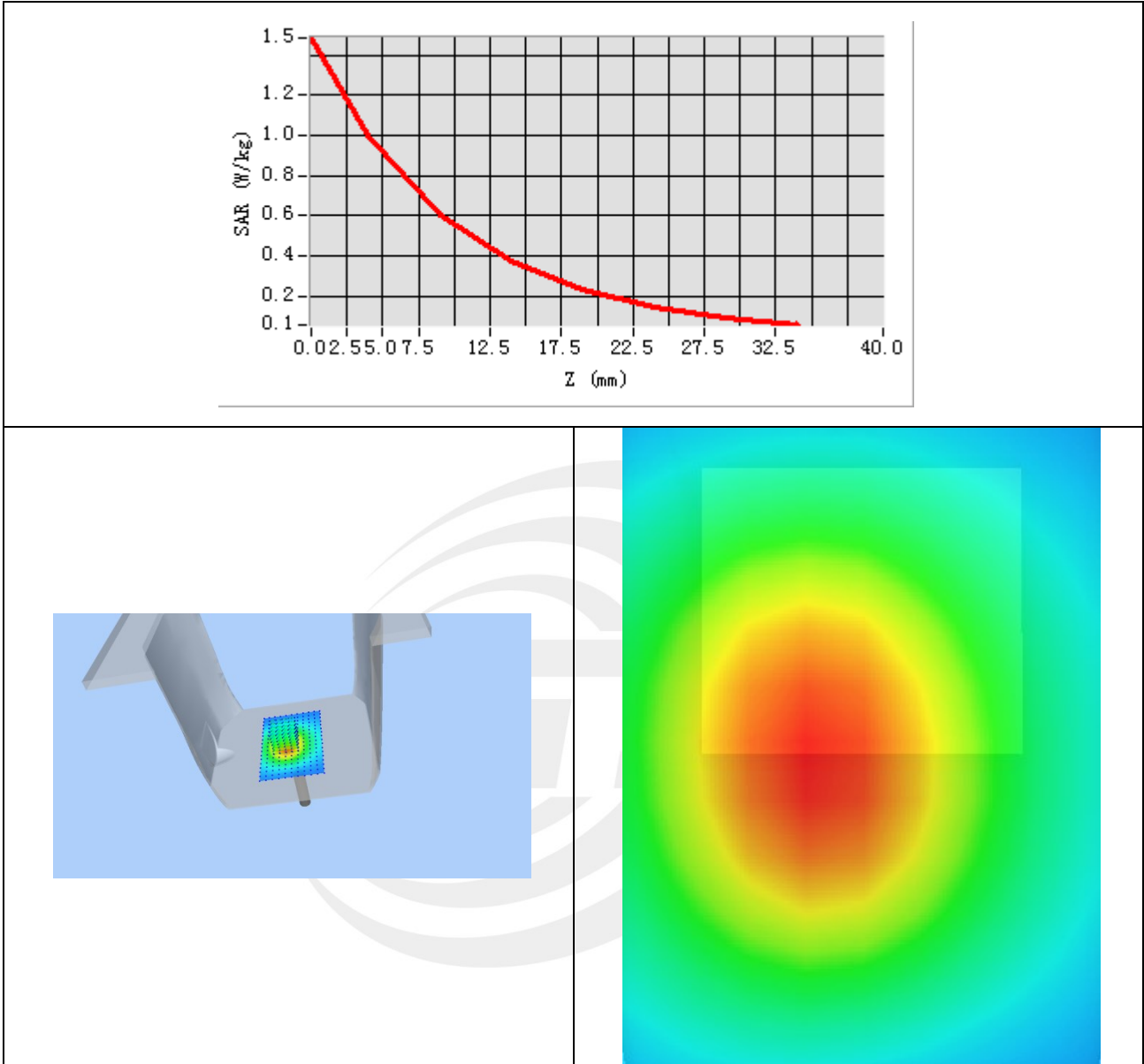

System Performance Check Data(1800MHz)

Type: Phone measurement (Complete)

Area scan resolution: dx=8mm, dy=8mm

Zoom scan resolution: dx=8mm, dy=8mm, dz=5mm

Date of measurement: 2021-09-17

Experimental conditions.

Phantom	Validation plane
Device Position	-
Band	1800MHz
Channels	-
Signal	CW
Frequency (MHz)	1800MHz
Relative permittivity	38.79
Conductivity (S/m)	1.38
Probe	SN 07/21 EPGO352
ConvF	1.60
Crest factor:	1:1

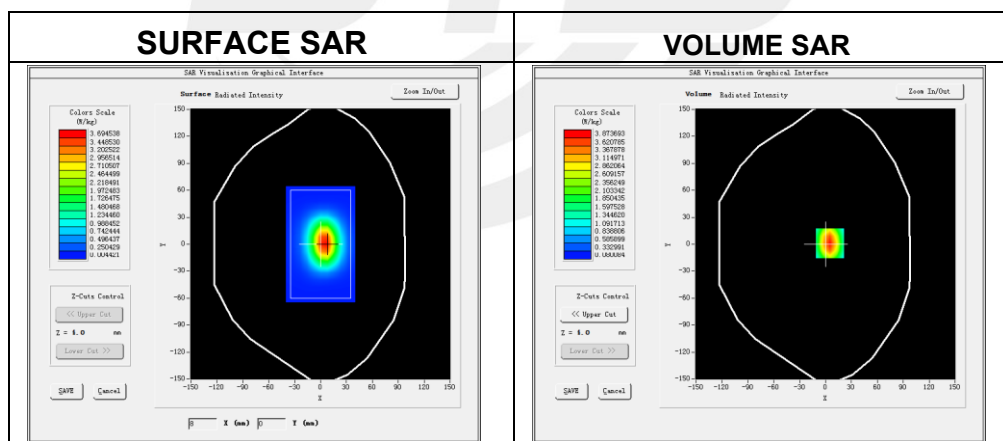

Maximum location: X=5.00, Y=1.00

SAR 10g (W/Kg)	2.074121
SAR 1g (W/Kg)	3.844111

Z Axis Scan

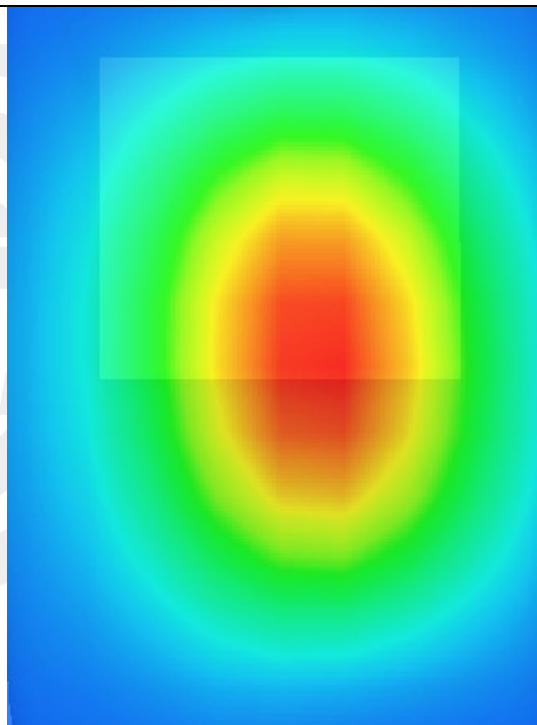
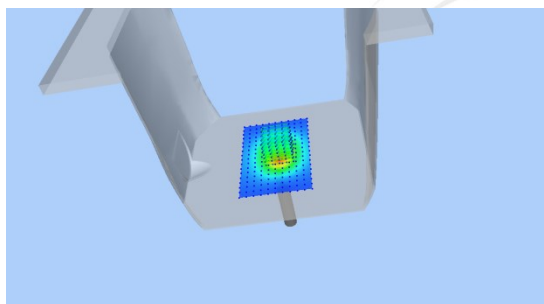
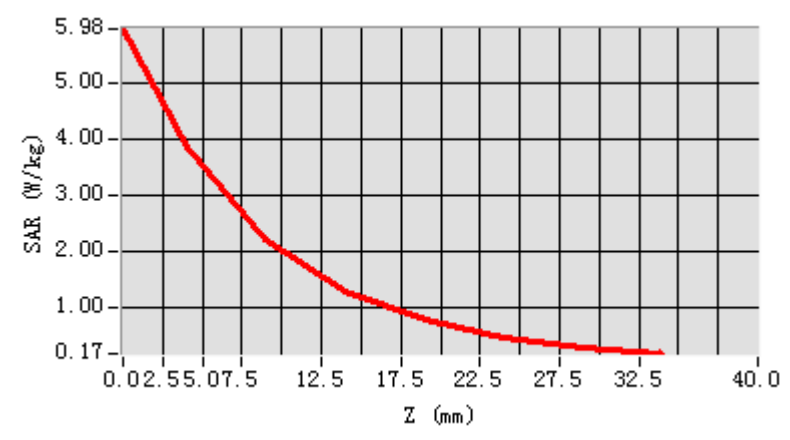



System Performance Check Data (1900MHz)

Type: Phone measurement (Complete)
 Area scan resolution: dx=8mm, dy=8mm
 Zoom scan resolution: dx=8mm, dy=8mm, dz=5mm
 Date of measurement: 2021-09-23

Experimental conditions.

Phantom	Validation plane
Device Position	-
Band	1900MHz
Channels	-
Signal	CW
Frequency (MHz)	1900MHz
Relative permittivity	40.65
Conductivity (S/m)	1.39
Probe	SN 07/21 EPGO352
ConvF:	1.78
Crest factor:	1:1

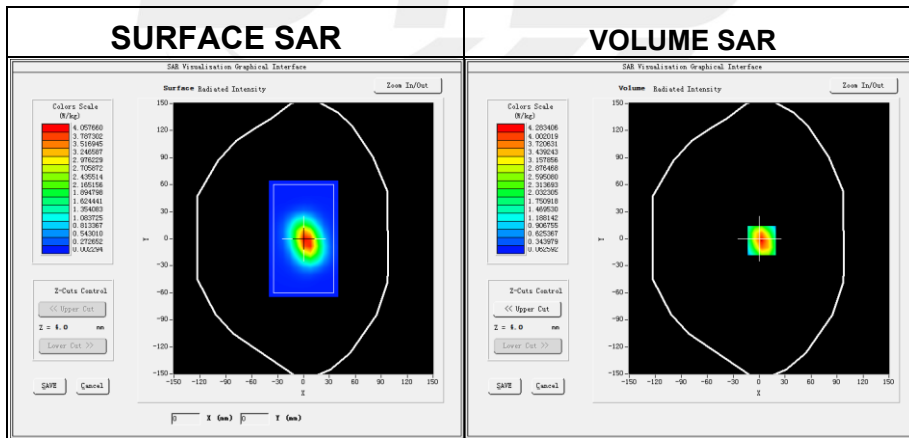

Maximum location: X=3.00, Y=-2.00

SAR 10g (W/Kg)	2.062710
SAR 1g (W/Kg)	4.017985

Z Axis Scan

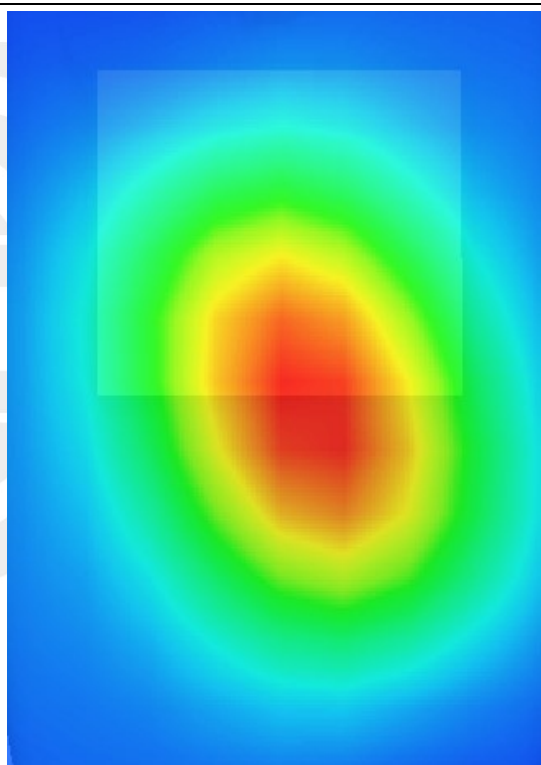
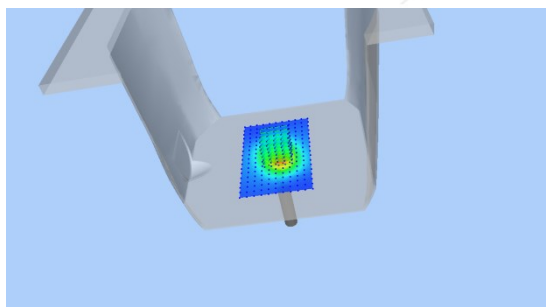
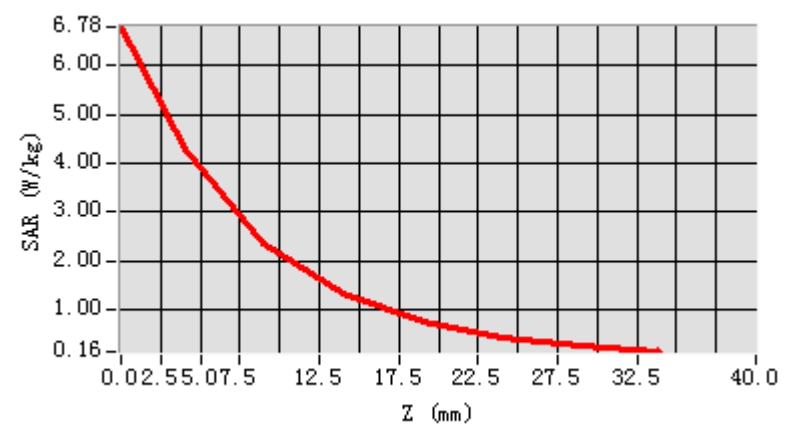

System Performance Check Data (2450MHz)

Type: Phone measurement (Complete)

Area scan resolution: dx=8mm, dy=8mm

Zoom scan resolution: dx=8mm, dy=8mm, dz=5mm

Date of measurement: 2021-09-24

Experimental conditions.

Device Position	Validation plane
Band	2450 MHz
Channels	-
Signal	CW
Frequency (MHz)	2450
Relative permittivity	39.88
Conductivity (S/m)	1.80
Probe	SN 07/21 EPGO352
ConvF	1.75
Crest factor:	1:1

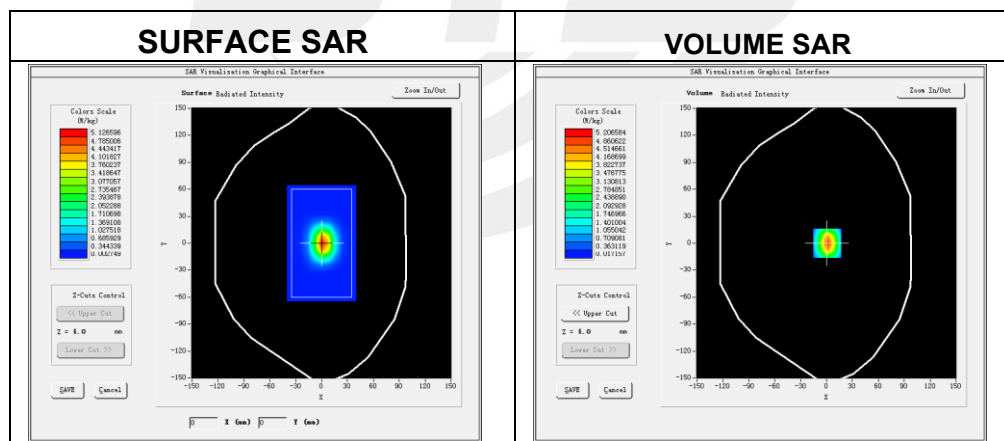

Maximum location: X=1.00, Y=0.00

SAR 10g (W/Kg)	2.367510
SAR 1g (W/Kg)	5.273020

Z Axis Scan

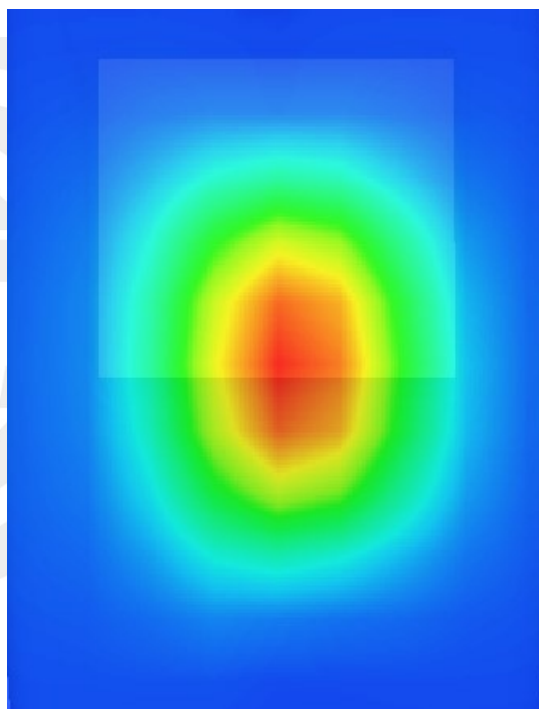
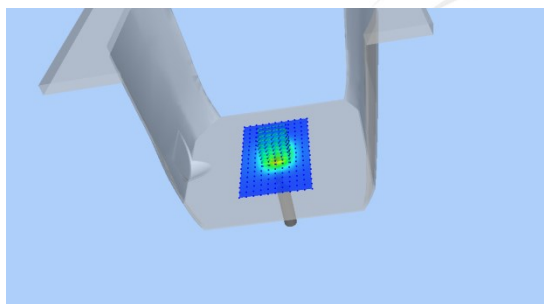
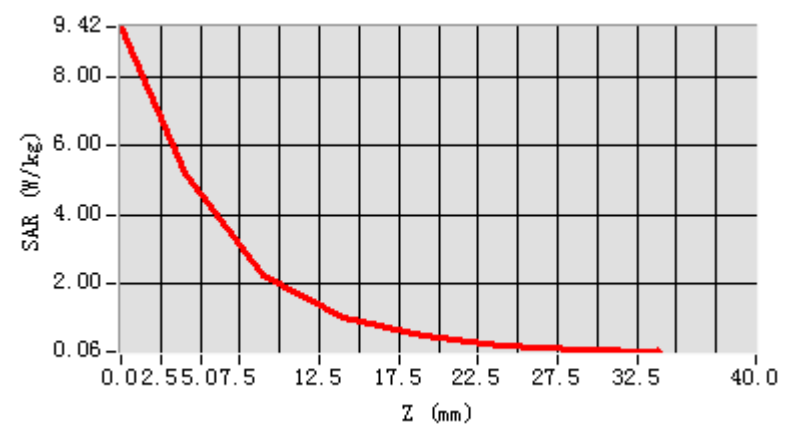

Appendix B. SAR Test Plots

Plot 1: DUT: Industrial PDA ; EUT Model: S917 V9

Test Date	2021-09-12
Probe	SN 07/21 EPGO352
Area Scan	dx=8mm, dy=8mm, h= 5.00 mm
Zoom Scan	5x5x7, dx=8mm, dy=8mm, dz=5mm, Complete/ndx=8mm, dy=8mm, h= 5.00 mm
Phantom	Validation plane
Device Position	Back Side
Band	GPRS 850
Channels	Low
Signal	Duty Cycle: 0.50 (Crest factor: 0.5)
Frequency (MHz)	824.2
Relative permittivity (real part)	41.99
Conductivity (S/m)	0.89

Maximum location: X=8.00, Y=3.00

SAR Peak: 1.69 W/kg

SAR 10g (W/Kg)	0.790872
SAR 1g (W/Kg)	1.155927

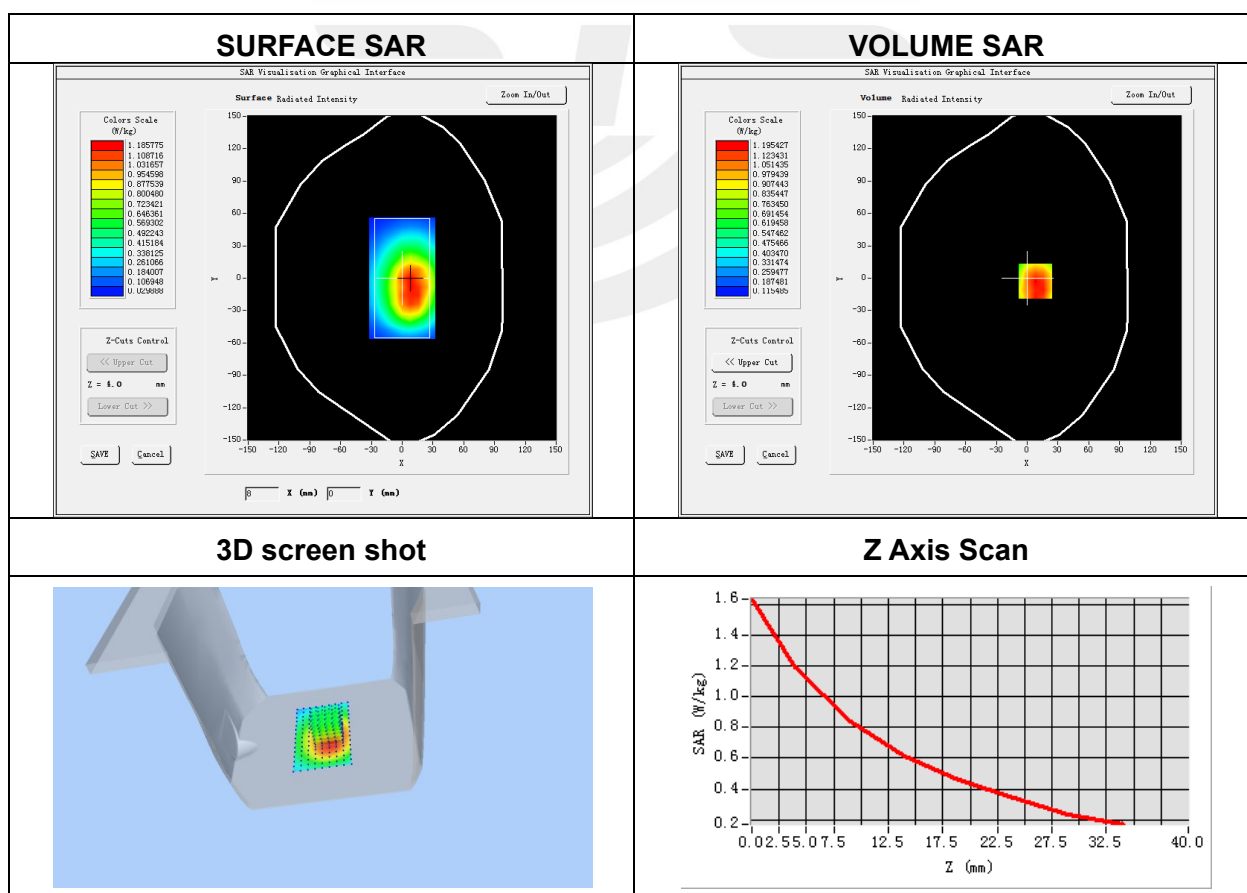

Plot 2: DUT: Industrial PDA ; EUT Model: S917 V9

Test Date	2021-09-23
Probe	SN 07/21 EPGO352
Area Scan	dx=8mm, dy=8mm, h= 5.00 mm
Zoom Scan	5x5x7, dx=8mm, dy=8mm, dz=5mm, Complete/ndx=8mm, dy=8mm, h= 5.00 mm
Phantom	Validation plane
Device Position	Back Side
Band	GPRS 1900
Channels	Low
Signal	Duty Cycle: 0.50 (Crest factor: 0.5)
Frequency (MHz)	1850.2
Relative permittivity (real part)	39.97
Conductivity (S/m)	1.40

Maximum location: X=-1.00, Y=46.00

SAR Peak: 2.13W/kg

SAR 10g (W/Kg)	0.551180
SAR 1g (W/Kg)	1.167120

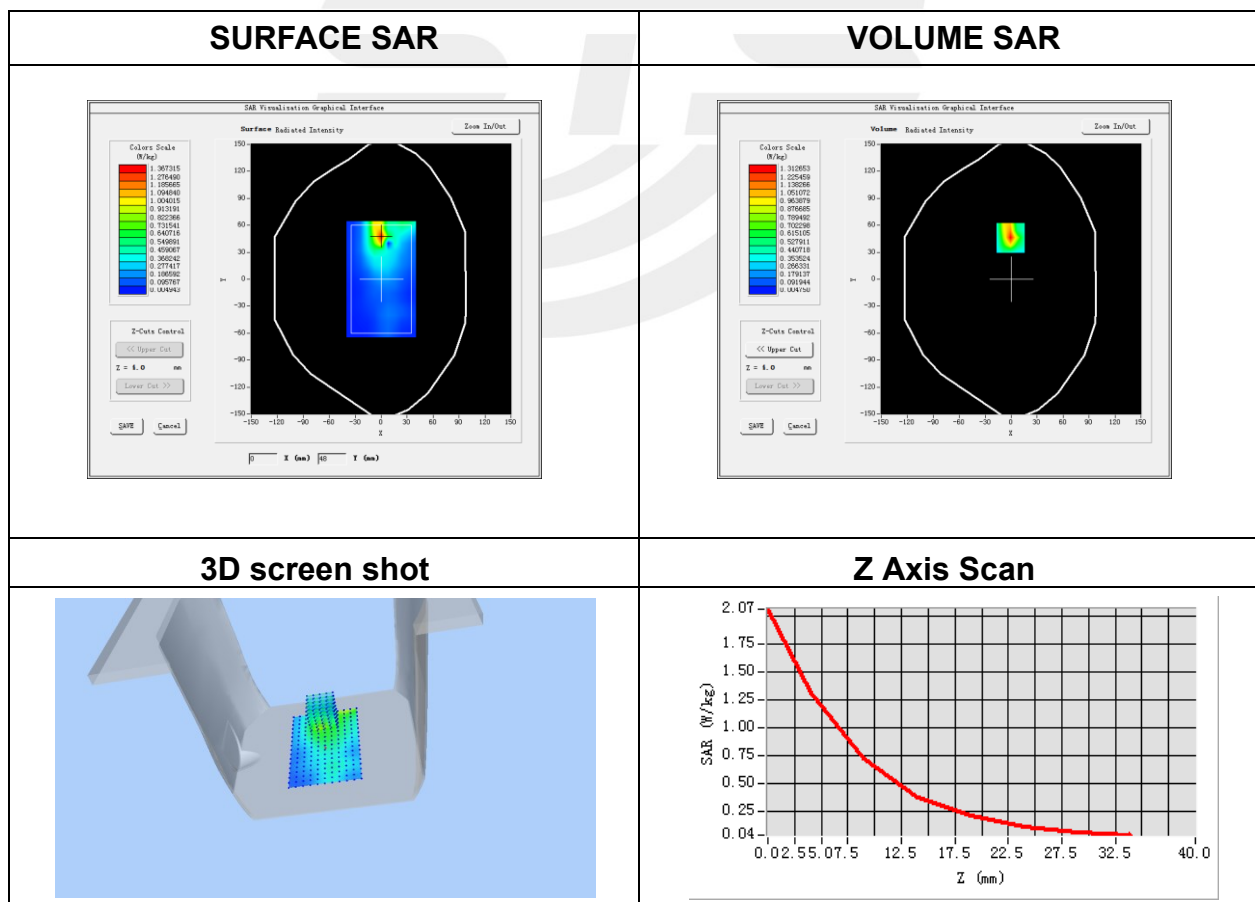

Plot 3: DUT: Industrial PDA ; EUT Model: S917 V9

Test Date	2021-09-23
Probe	SN 07/21 EPGO352
ConvF	1.84
Area Scan	dx=8mm, dy=8mm, h= 5.00 mm
Zoom Scan	5x5x7, dx=8mm, dy=8mm, dz=5mm, Complete/ndx=8mm, dy=8mm, h= 5.00 mm
Phantom	Validation plane
Device Position	Back Side
Band	WCDMA II
Channels	High
Signal	WCDMA (Crest factor: 1.0)
Frequency (MHz)	1907.6
Relative permittivity (real part)	40.06
Conductivity (S/m)	1.44

Maximum location: X=-26.00, Y=-5.00

SAR Peak: 1.74 W/kg

SAR 10g (W/Kg)	0.445726
SAR 1g (W/Kg)	0.922261

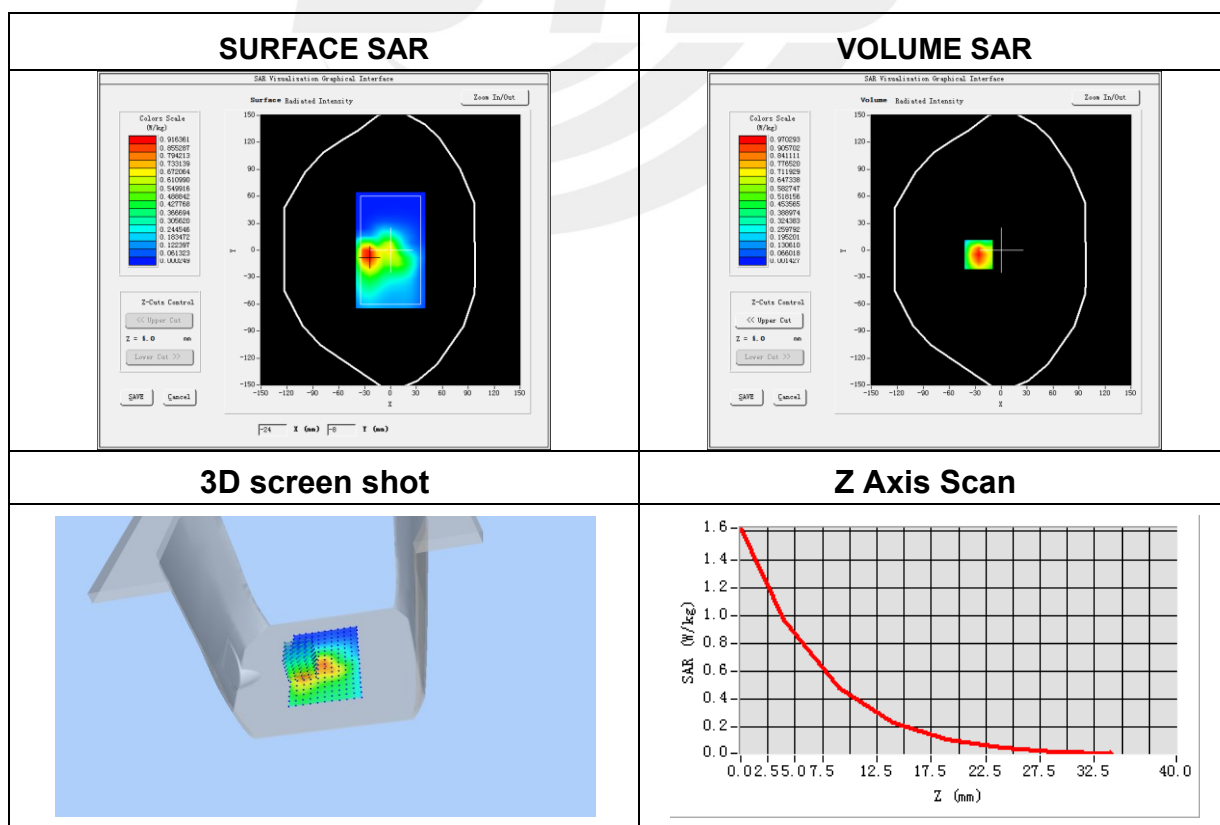

Plot 4: DUT: Industrial PDA ; EUT Model: S917 V9

Test Date	2021-09-17
Probe	SN 07/21 EPGO352
ConvF	1.60
Area Scan	dx=8mm, dy=8mm, h= 5.00 mm
Zoom Scan	5x5x7, dx=8mm, dy=8mm, dz=5mm, Complete/ndx=8mm, dy=8mm, h= 5.00 mm
Phantom	Validation plane
Device Position	Back Side
Band	WCDMA IV
Channels	Low
Signal	WCDMA (Crest factor: 1.0)
Frequency (MHz)	1712.6
Relative permittivity (real part)	39.86
Conductivity (S/m)	1.32

Maximum location: X=-7.00, Y=-30.00

SAR Peak: 1.55 W/kg

SAR 10g (W/Kg)	0.619203
SAR 1g (W/Kg)	1.035936

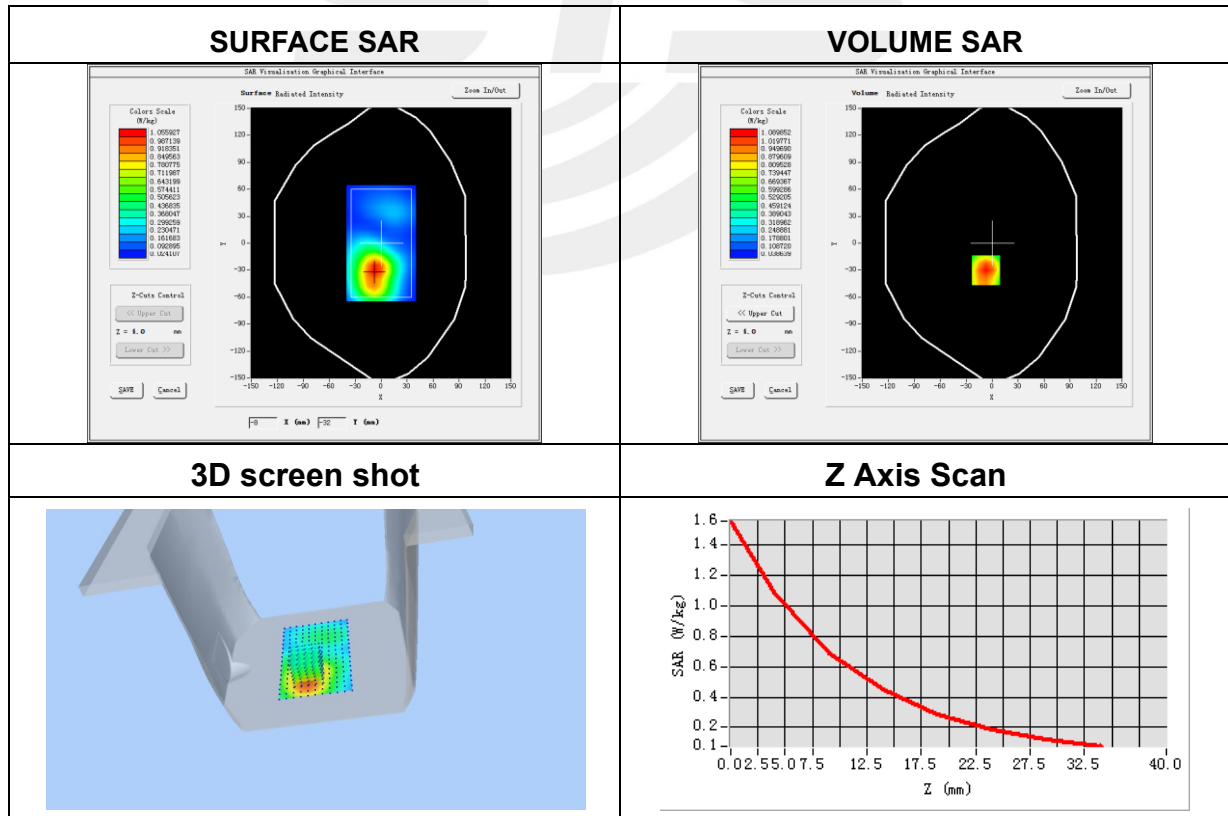

Plot 5: DUT: Industrial PDA ; EUT Model: S917 V9

Test Date	2021-09-12
Probe	SN 07/21 EPGO352
ConvF	1.60
Area Scan	dx=8mm, dy=8mm, h= 5.00 mm
Zoom Scan	5x5x7, dx=8mm, dy=8mm, dz=5mm, Complete/ndx=8mm, dy=8mm, h= 5.00 mm
Phantom	Validation plane
Device Position	Back Side
Band	WCDMA V
Channels	Low
Signal	WCDMA (Crest factor: 1.0)
Frequency (MHz)	826.4
Relative permittivity (real part)	41.82
Conductivity (S/m)	0.90

Maximum location: X=6.00, Y=50.00

SAR Peak: 2.16 W/kg

SAR 10g (W/Kg)	0.516861
SAR 1g (W/Kg)	1.123768

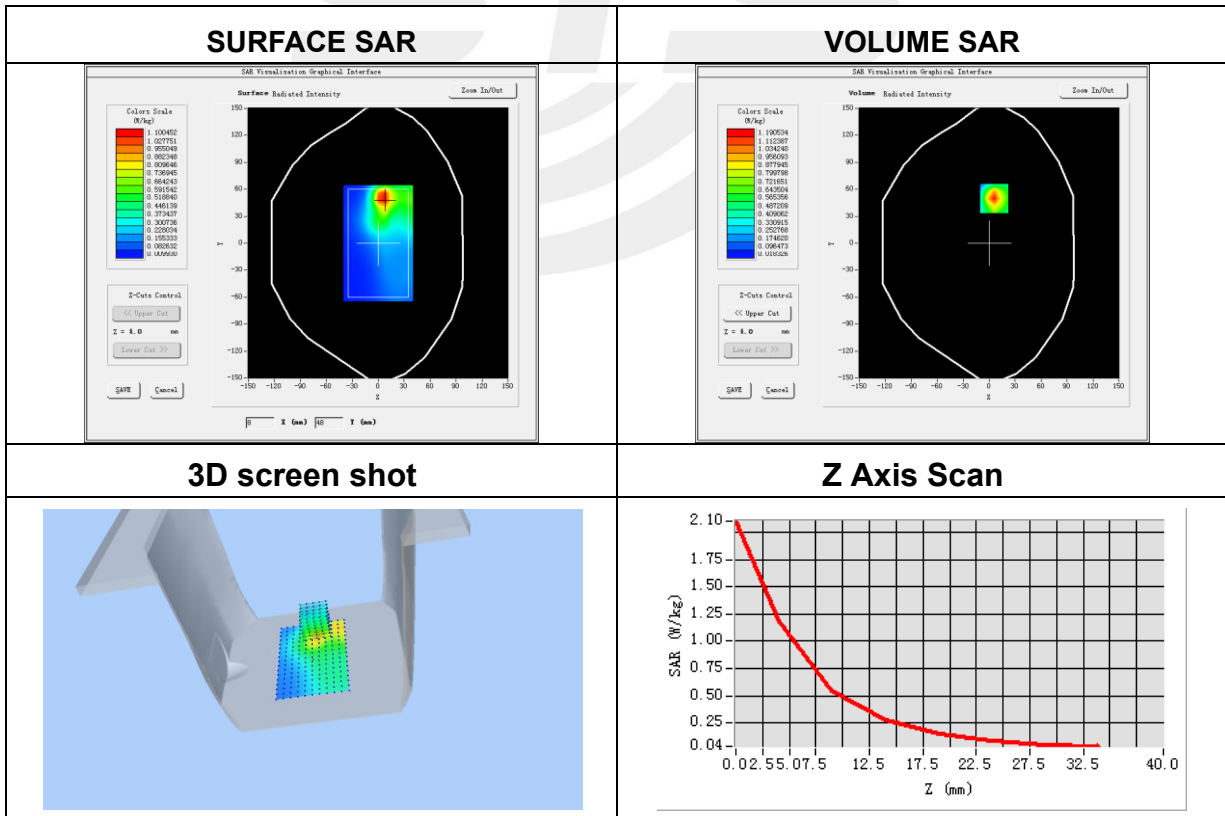

Plot 6: DUT: Industrial PDA ; EUT Model: S917 V9

Test Date	2021-09-08
Probe	SN 07/21 EPGO352
Area Scan	dx=8mm, dy=8mm, h= 5.00 mm
Zoom Scan	5x5x7, dx=8mm, dy=8mm, dz=5mm, Complete/ndx=8mm, dy=8mm, h= 5.00 mm
Phantom	Validation plane
Device Position	Back side
Band	LTE Band 2 (RB 1)
Channels	Low
Signal	LTE (Crest factor: 1.0)
Frequency (MHz)	1860
Relative permittivity (real part)	39.05
Conductivity (S/m)	1.37

Maximum location: X=-27.00, Y=0.00

SAR Peak: 1.76 W/kg

SAR 10g (W/Kg)	0.443123
SAR 1g (W/Kg)	0.933380

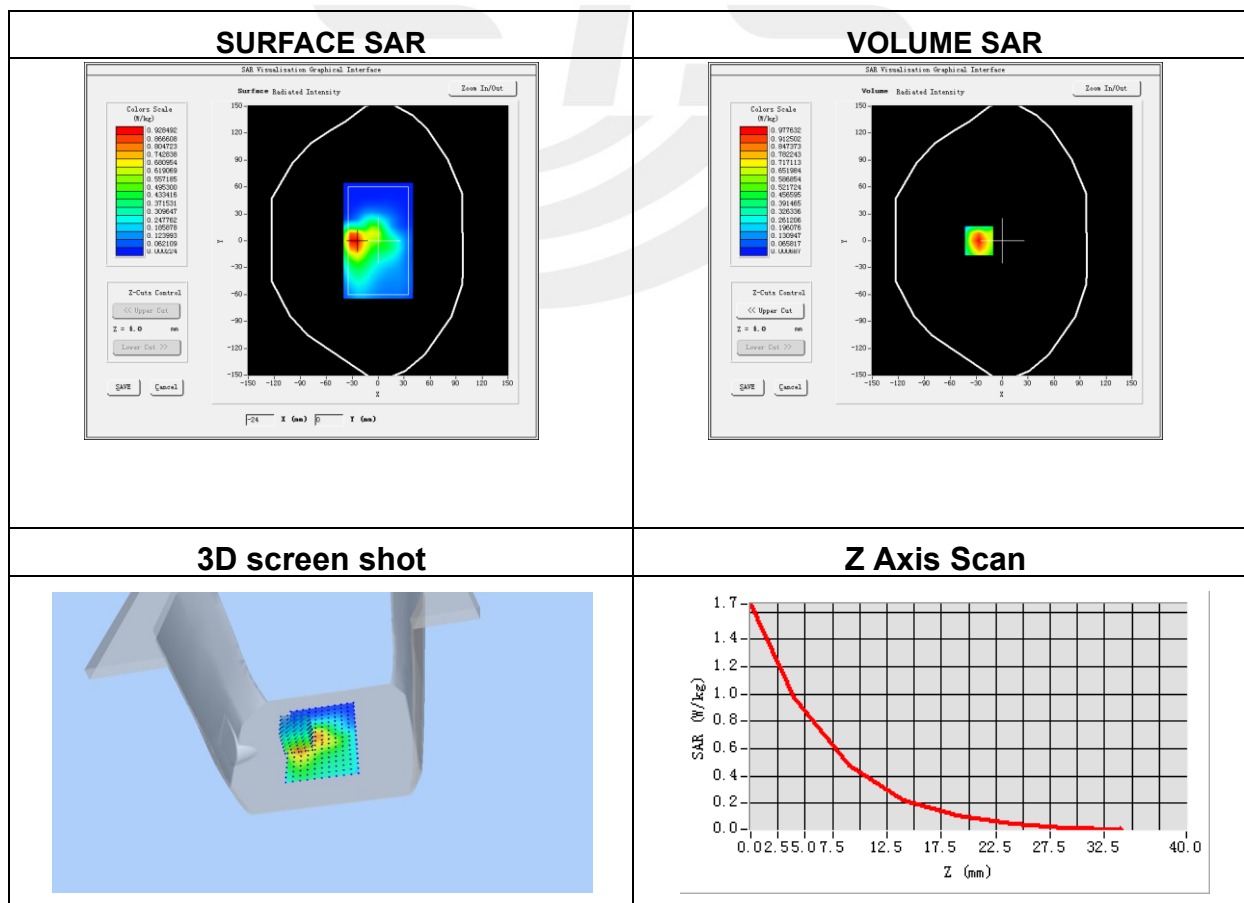

Plot 7: DUT: Industrial PDA ; EUT Model: S917 V9

Test Date	2021-09-09
Probe	SN 07/21 EPGO352
Area Scan	dx=8mm, dy=8mm, h= 5.00 mm
Zoom Scan	5x5x7, dx=8mm, dy=8mm, dz=5mm, Complete/ndx=8mm, dy=8mm, h= 5.00 mm
Phantom	Validation plane
Device Position	Back side
Band	LTE Band 4(RB 1)
Channels	Middle
Signal	LTE (Crest factor: 1.0)
Frequency (MHz)	1732.5
Relative permittivity (real part)	39.75
Conductivity (S/m)	1.35

Maximum location: X=-1.00, Y=23.00

SAR Peak: 1.36 W/kg

SAR 10g (W/Kg)	0.428951
SAR 1g (W/Kg)	0.822542

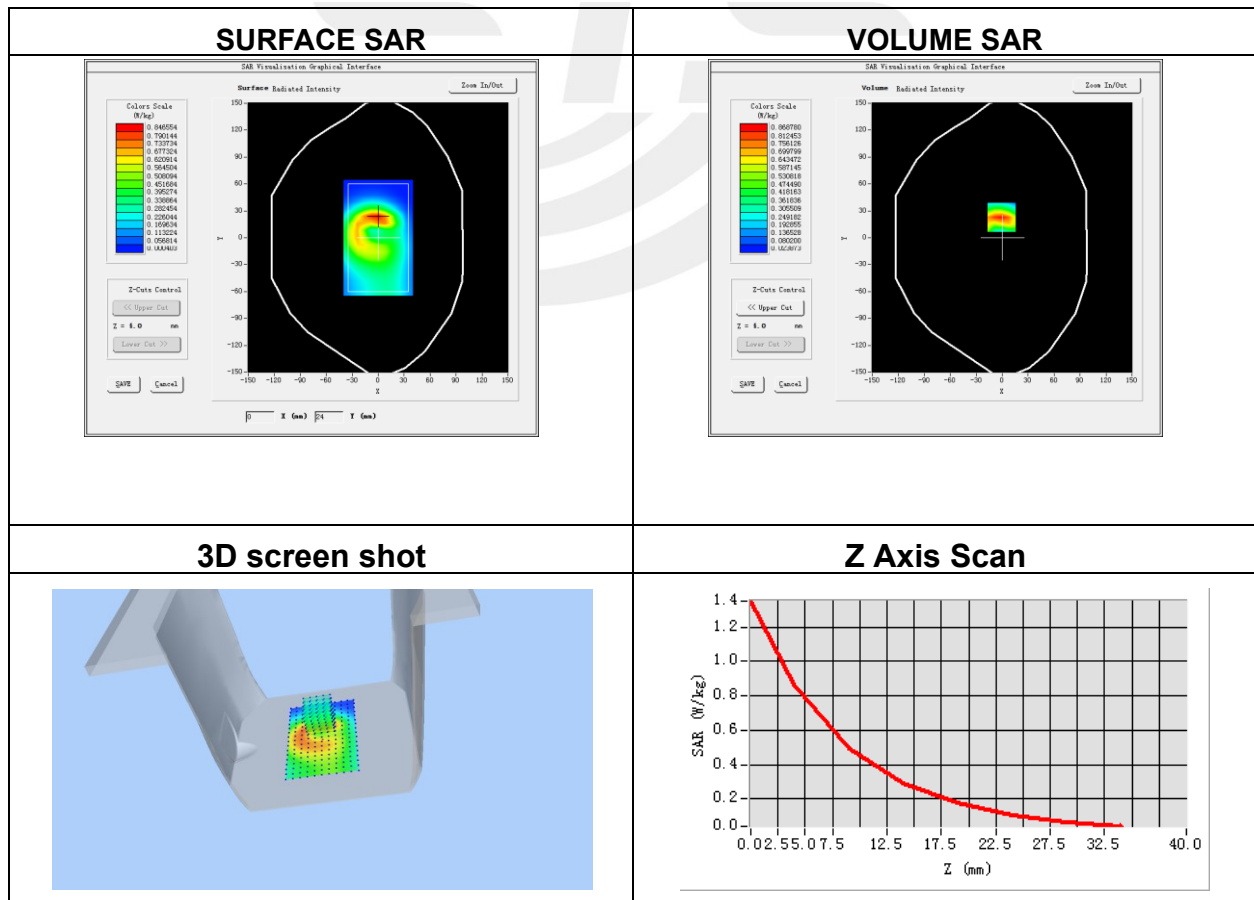

Plot 8: DUT: Industrial PDA ; EUT Model: S917 V9

Test Date	2021-09-09
Probe	SN 07/21 EPGO352
Area Scan	dx=8mm, dy=8mm, h= 5.00 mm
Zoom Scan	5x5x7, dx=8mm, dy=8mm, dz=5mm, Complete/ndx=8mm, dy=8mm, h= 5.00 mm
Phantom	Validation plane
Device Position	Back side
Band	LTE Band 4(RB 1)
Channels	High
Signal	LTE (Crest factor: 1.0)
Frequency (MHz)	844
Relative permittivity (real part)	43.14
Conductivity (S/m)	0.91

Maximum location: X=-1.00, Y=39.00

SAR Peak: 2.14 W/kg

SAR 10g (W/Kg)	0.511978
SAR 1g (W/Kg)	1.115389

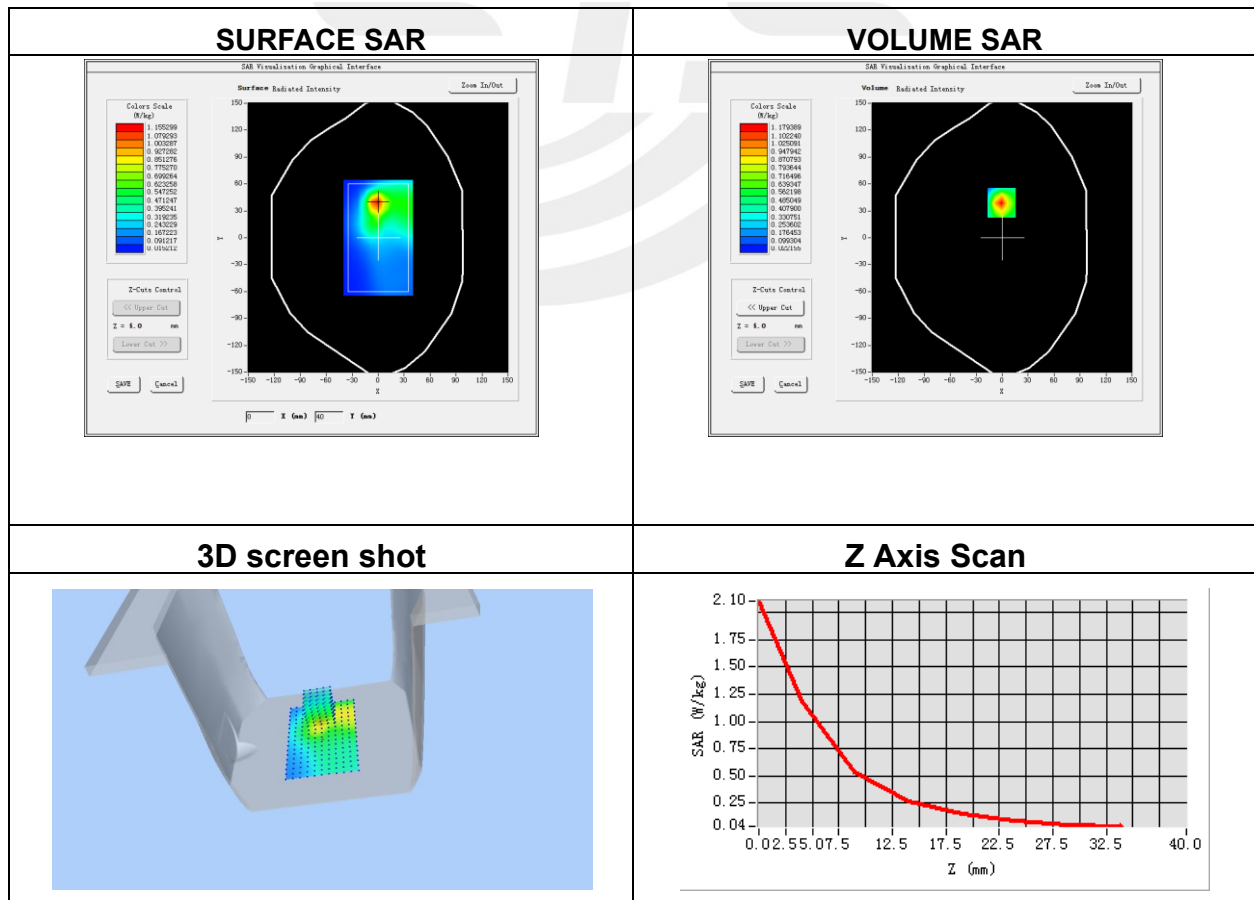

Plot 14: DUT: Industrial PDA; EUT Model: S917 V9

Test Date	2021-09-08
Probe	SN 07/21 EPGO352
Area Scan	dx=8mm, dy=8mm, h= 5.00 mm
Zoom Scan	5x5x7, dx=8mm, dy=8mm, dz=5mm, Complete/ndx=8mm, dy=8mm, h= 5.00 mm
Phantom	Validation plane
Device Position	Front Side
Band	IEEE 802.11b ISM
Channels	Mid
Signal	IEEE802.b (Crest factor: 1.0)
Frequency (MHz)	2437
Relative permittivity (real part)	37.93
Conductivity (S/m)	1.75

Maximum location: X=16.00, Y=-34.00

SAR Peak: 0.69 W/kg

SAR 10g (W/Kg)	0.126086
SAR 1g (W/Kg)	0.329037

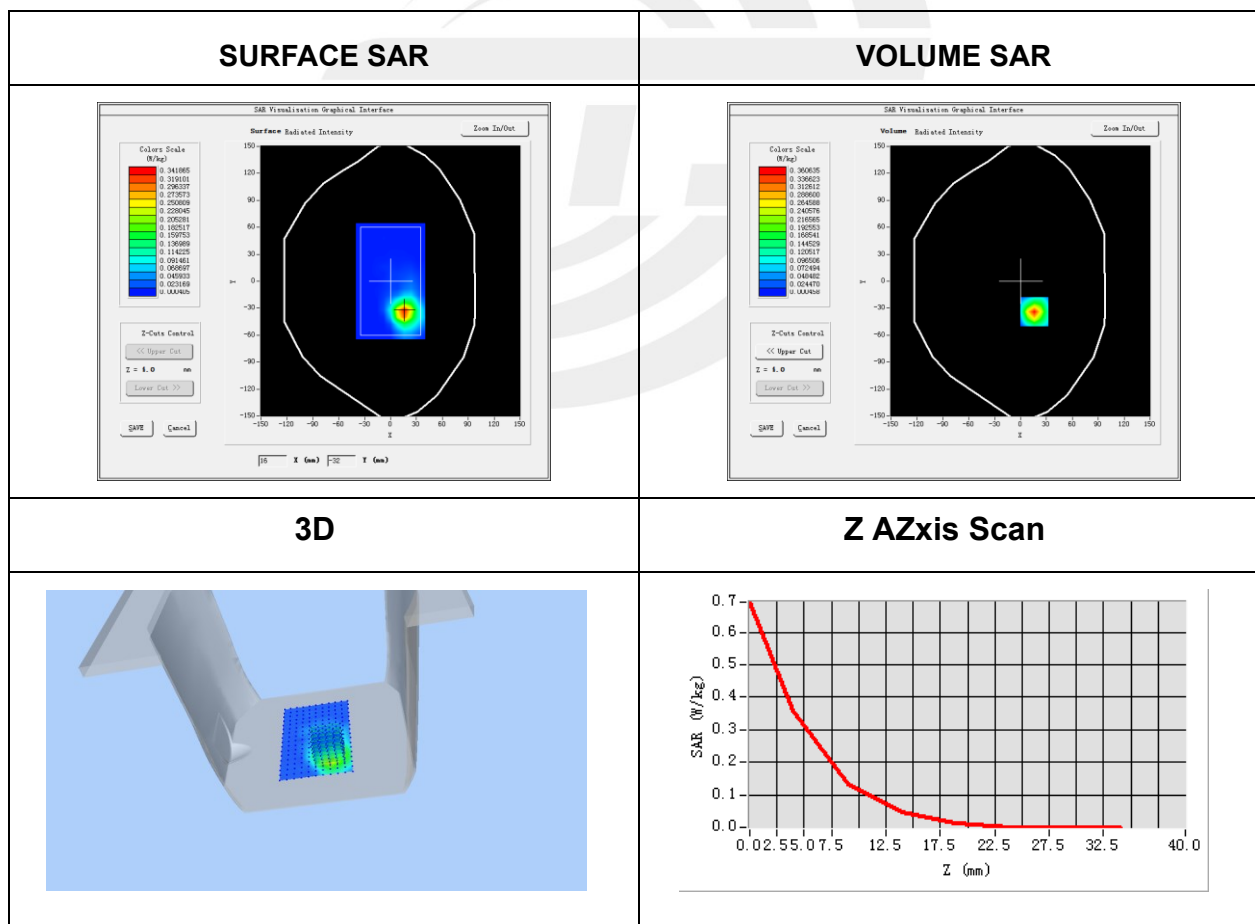



Appendix C. Probe Calibration and Dipole Calibration Report

Refer the appendix Calibration Report.

※※※※END OF THE REPORT※※※※

